

MODULAR TABLE TOP CONVEYOR

OmniMetalcraftcorp.



CONVEYOR COMPONENTS



COPE

- 1' standard length
- +/- 15° elevation change
- See engineering for custom applications



CURVE

- 30°, 45°, 90° standard
- 24" CL radius
- 8" frame
- 6" tangents each end

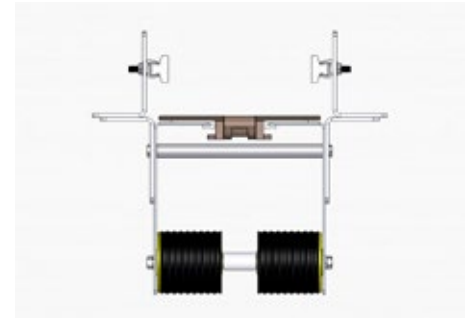

OPEN TOP

- UHMW carryway wearstrip
- Roller return



DRIVE

- 30" standard length
- 8" standard depth
- 2-bolt flange bearing
- 2-piece split nylon sprocket
- Hollowshaft drive standard
- Shown with optional finger guard



INTERMEDIATE

- 1' increments up to 10' long
- Custom lengths available
- 8" formed frame

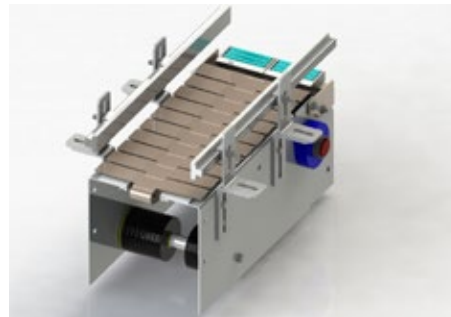
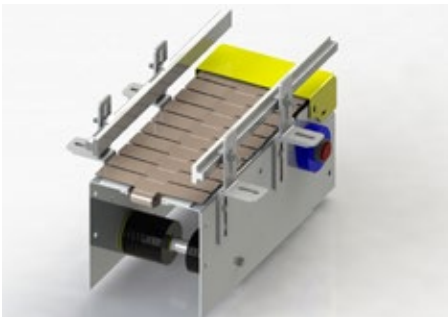

IDLE

- 18" standard length
- 8" formed frame
- 2-bolt flange bearing
- 2-piece split nylon sprocket
- Shown with optional finger guard



SUPPORTS

- H-style formed angle
- +/-2" height adjustment
- Standard elevation ranges: 24", 30", 36", 42", 48"
- Sanitary stainless tube style supports available

MODULAR TABLE TOP CONVEYOR

CONVEYOR CHAIN

820 LF **intralox**
CONVEYOR

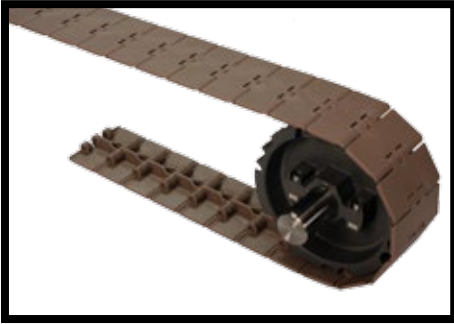

Drive P1070102

821 LF **intralox**
CONVEYOR

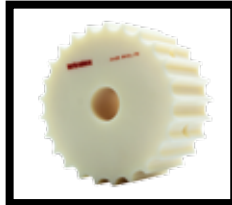

Idle P1070060

882 LF **intralox**
CONVEYOR

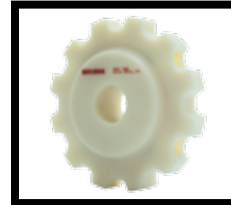
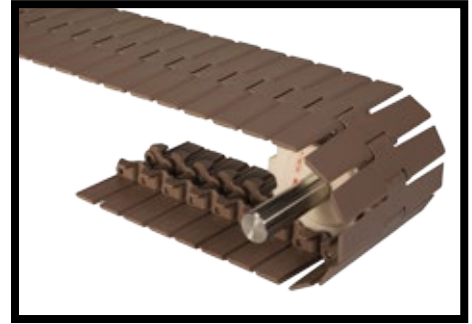

Idle P1070125

879 UP **intralox**
CONVEYOR



Idle P1070112

880 LF **intralox**
CONVEYOR



Idle P1070112

**OTHER CHAIN
BRANDS ARE
AVAILABLE UPON
REQUEST.**

GENERAL CONVEYOR SPECIFICATIONS

- Modular construction
- 8" formed angle frames, 8" on drive and idler ends
- Galvanized steel, powder coated galvanized steel, stainless steel
- Bolt together construction with tube spreaders
- Open or closed top construction
- Adjustable single high guide rail with UHMW wear strip, double high available
- Roller return standard
- Two piece thermoplastic sprockets
- Shaft mount standard, underhung drive mount available
- Dead plates and roller plate transitions available
- Formed angle and welded tube style floor supports available

MODULAR TABLE TOP CONVEYOR

CUSTOM SOLUTIONS



Dual Lane Straight and Curve Metal Chain Modular Table Top Conveyors with Fixed Angle Side Guides and Pneumatic Divert Arms

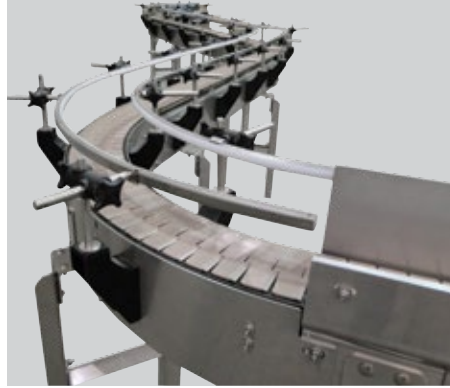

Stainless Steel Modular Table Top Conveyor with Plastic Chain, Adjustable Rail UHMW Side Guides and High Fixed Side Guides



Stainless Steel Modular Table Top Conveyor System with Plastic Chain, Double High Adjustable Rail UHMW Side Guides and Manual Divert Arm with Adjustable Rail UHMW Side Guides

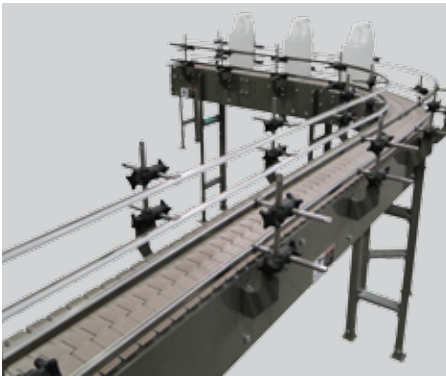

Modular Table Top Conveyor with Double High Adjustable Rail UHMW Side Guides

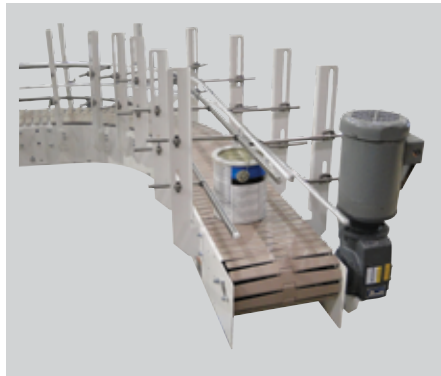

Modular Table Top Conveyor with Plastic Chain with Double High Adjustable Rail UHMW Side Guides

EQUIPMENT SETS

COMBINER

- A combiner is used to orient a mass flow of round product into single file
- 10' standard length
- Available with straight running and side flexing tab style chains
- Bead rail side guides optional

INLINE TRANSFER

- An inline transfer is used to transition small or unstable product from one chain to another that will not convey over a dead plate
- Inline transfers maintain linear product flow direction with the use of side flexing tab chain
- Side flexing tab style chains are required

90° DEAD PLATE TURN

- Back pressure required to accommodate transition across dead plate
- Roller plate transitions available
- Available with straight running or side flexing chain

PARALLEL TRANSFER

- A parallel transfer is used to transition small or unstable product from one chain to another that will not convey over a dead plate
- Parallel transfers shift product perpendicular to flow direction without side flexing tab chain
- Available with straight running and side flexing tab style chains