

SOLUTION SPOTLIGHTS

2011 SERIES

OmniMetalcraftcorp.

24V Flat Motor Driven Roller Conveyor	Page
Automotive Assembly Prep Line 307	33
Chain Driven FMDR Parts Staging 308	34
Flat Motor ZPA 303	29
Packout Line Automation 306	32
24V Motor Driven Roller Conveyor	
3 Tier Glass Handling & Storage MDR 302	28
MDR Battery Storage System 304	30
MDR Curve 305	31
Activated Roller Belt™ Conveyor	
ARB Aligning Conveyor 504	46
ARB Retractable Bump Turn 503	45
Row Forming System Utilizing ARB 501	43
Belt Conveyor	
Bag Turner 403	37
Block Handling Conveyor 401	35
Cement Bag Take-Away 405	39
Dairy Processing Sanitary Conveyor 402	36
Dual Belt Exhaust Conveyor 406	40
Dual Direction Discharge Conveyor 407	41
Pivot Belt Conveyor 203	19
Tight Transition Tile Conveyor 408	42
Wood Finishing Belt Curve 404	38
Belt Driven Live Roller Conveyor	
Centering Herringbone BDLR 601	53
Chain Conveyor	
Adjustable Chain Conveyor 111	12
Pallet Destacker with CDLR 205	21
Pick and Place Robotic Palletizer 114	15
Rotor Turnover 113	14
Seat Pallet Stacker 207	23
Steel Water Tank Manufacturing 806	63
Vertical Lift Arm Chain Conveyor 202	18
Chain Driven Live Roller Conveyor	
Custom AGV Conveyor 102	3
Foundry Lift Gate 115	16
Foundry Sand Mold Shake Out Station 210	26
Heavy Duty Roll Handling Turntable 208	24
Heavy Duty Stainless Steel Conveyor 110	11
Infeed and Discharge Conveyor 101	2
MDR Battery Storage System 304	30
Pack Out Station 109	10
Pallet Destacker with CDLR 205	21
Pallet Packer Station with CDLR 106	7
Pneumatic Puller with CDLR 105	6
Robotic Crate Filling Stations 204	20
Roll Handling Upender 802	59
Rotor Turnover 113	14
Stainless Steel Tote Handling 104	5
Steel Water Tank Manufacturing 806	63
Tire Unloading System 507	49
Transferring Empty Pallets 209	25
T-Car with Traversing CDLR Deck 201	17
Tube Handling CDLR Lift Gate 108	9
Tube Sorter with CDLR 107	8
Chain Transfers	
Chain Driven FMDR Parts Staging 308	34
Custom Saw Feeding Equipment 112	13
Foundry Lift Gate 115	16
Level Lift Chain Transfer 103	4
MDR Battery Storage System 304	30
Pack Out Station 109	10

Chain Transfers (Continued)	Page
Stainless Steel Tote Handling 104	5
Steel Water Tank Manufacturing 806	63
Gravity Conveyor	
Automotive Assembly Prep Line 307	33
Ball Transfer Filling Workstation 703	56
Cement Bag Take-Away 405	39
Custom Saw Feeding Equipment 112	13
Heavy Duty Stainless Steel 110	11
Roll Handling Upender 802	59
Seat Pallet Stacker 207	23
Split Lane Gravity Conveyor Pallet Singulator 704	57
Steel Water Tank Manufacturing 806	63
Tire and Wheel Assembly Incline 510	52
Tire Storage and Assembly 702	55
Tire Unloading System 507	49
Vacuum Cup Gravity Conveyor 701	54
Lineshaft Conveyor	
Helix Lineshaft Conveyor 301	27
Metal Belt Conveyor	
Cement Bag Take-Away 405	39
Small Product Transition Conveyor 901	65
Modular Plastic Belt Conveyor	
ARB Retractable Bump Turn 503	45
Frozen Vegetable Sanitary Incline 505	47
Heavy Duty Plastic Belt Conveyor 502	44
Inkjet Printing and Case Turning 506	48
Robotic Crate Filling Stations 204	20
Small Footprint Elevation Change 509	51
Tire and Wheel Assembly Incline 510	52
Tire Unloading System 507	49
Modular Table Top Conveyor	
Vertical Sorting Table Top Conveyor 508	50
Reciprocating Vertical Conveyor	
3 Tier Glass Handling & Storage MDR 302	28
Scissor Lift	
Custom Pipe Handling Scissor Lift 804	61
Foundry Sand Mold Shake Out Station 210	26
Heavy Duty High Cycle Scissor Lift 803	60
MDR Battery Storage System 304	30
Pick and Place Robotic Palletizer 114	15
Scissor Lift Wheel Assembly Station 801	58
Tire Mounting Lift Station 807	64
Stackers and Destackers	
Pallet Stacker with CDLR 205	21
Seat Pallet Stacker 207	23
Tilters	
Bin Tilter 805	62
Foundry Sand Mold Shake Out Station 210	26
Robotic Crate Filling Stations 204	20
Transfer Cars	
Foundry Sand Mold Shake Out Station 210	26
MDR Battery Storage System 304	30
Transferring Empty Pallets 209	25
T-Car with Traversing Deck 201	17
Turntables	
Automotive Glass Inspection Turntable 206	22
Heavy Duty Roll Handling Turntable 208	24
Upenders	
Roll Handling Upender 802	59
Steel Water Tank Manufacturing 806	63

Appliance	Page
Level Lift Chain Transfer 103	4
Pneumatic Puller with CDLR 105	6
Automotive	
Automotive Assembly Prep Line 307	33
Automotive Glass Inspection Turntable 206	22
Bin Tilter 805	62
Chain Driven FMDR Parts Staging 308	34
Custom AGV Conveyor 102	3
Dual Belt Exhaust Conveyor 406	40
MDR Curve 305	31
Rotor Turnover 113	14
Seat Pallet Stacker 207	23
Split Lane Gravity Conveyor Pallet Singulator 704	57
Tire and Wheel Assembly Incline 510	52
Tire Storage and Assembly 702	55
Tire Unloading System 507	49
Battery	
MDR Battery Storage System 304	30
Pneumatic Puller with CDLR 105	6
Cabinetry, Furniture and Wood Finishing	
Centering Herringbone BDLR 601	53
Wood Finishing Belt Curve 404	38
Chemical	
Level Lift Chain Transfer 103	4
Pneumatic Puller with CDLR 105	6
Concrete Block and Cement	
Block Handling Conveyor 401	35
Cement Bag Take-Away 405	39
Heavy Duty Plastic Belt Conveyor 502	44
Small Product Transition Conveyor 901	65
Construction Materials	
Block Handling Conveyor 401	35
Cement Bag Take-Away 405	39
Heavy Duty Plastic Belt Conveyor 502	44
Packout Line Automation 306	32
Small Product Transition Conveyor 901	65
Infeed and Discharge 101	2
Tight Transition Tile Conveyor 408	42
Vacuum Cup Gravity Conveyor 701	54
Distribution and Warehousing	
Custom AGV Conveyor 102	3
Equipment and Machinery	
Scissor Lift Wheel Assembly Station 801	58
Tire Mounting Lift Station 807	64
Transferring Empty Pallets 209	25
T-Car with Traversing Deck 201	17
Food and Beverage	
ARB Aligning Conveyor 504	46
ARB Retractable Bump Turn 503	45
Bag Turner 403	37
Custom AGV Conveyor 102	3
Dairy Processing Sanitary Conveyor 402	36
Frozen Vegetable Sanitary Incline 505	47
Heavy Duty Stainless Steel Conveyor 110	11
Level Lift Chain Transfer 103	4
Pneumatic Puller with CDLR 105	6
Row Forming System Utilizing ARB 501	43
Small Footprint Elevation Change 509	51
Stainless Steel Tote Handling 104	5
Vertical Sorting Table Top Conveyor 508	50

Foundry	Page
Foundry Lift Gate 115	16
Foundry Sand Mold Shake Out Station 210	26
Pivot Belt Conveyor 203	19
Glass	
3 Tier Glass Handling & Storage MDR 302	28
Automotive Glass Inspection Turntable 206	22
Robotic Crate Filling Stations 204	20
Consumable Goods	
Dual Direction Discharge Conveyor 407	41
Inkjet Printing and Case Turning 506	48
Flat Motor ZPA 303	29
Helix Lineshaft Conveyor 301	27
Row Forming System Utilizing ARB 501	43
Industrial Manufacturing	
Custom AGV Conveyor 102	3
Heavy Duty High Cycle Scissor Lift 803	60
Stainless Steel Tote Handling 104	5
Metal and Steel	
Adjustable Chain Conveyor 111	12
Custom Pipe Handling Scissor Lifts 804	61
Custom Saw Feeding Equipment 112	13
Infeed and Discharge Conveyor 101	2
Pallet Packer Station with CDLR 106	7
Steel Water Tank Manufacturing 806	63
Tube Handling CDLR Lift Gate 108	9
Tube Sorter with CDLR 107	8
Parcel	
Pick and Place Robotic Palletizer 114	15
Plastic and Rubber Manufacturing	
Custom AGV Conveyor 102	3
Pack Out Station 109	10
Pallet Destacker with CDLR 205	21
Textile Mill	
Custom AGV Conveyor 102	3
Roll Handling Upender 802	59
Vertical Lift Arm Chain Conveyor 202	18
Wood and Paper	
Custom AGV Conveyor 102	3
Heavy Duty Roll Handling Turntable 208	24
Infeed and Discharge Conveyor 101	2

INFEED AND DISCHARGE CONVEYOR NO: 101

THE APPLICATION: Infeed and discharge conveyor

THE PRODUCT: Chain Driven Live Roller Conveyor

THE INDUSTRY: Metal and Steel, Lumber, Pipe, Finished Wood Products, Construction Materials

THE NEED: Manufacturer's and distributors need conveyor to move materials up to, through and away from processing equipment

THE SOLUTION: Omni Metalcraft Corp. can provide just the right conveyor to complement your processing equipment. Our engineers will work with you to understand the application and recommend the right conveyor design to suit your needs. We'll even powder coat the equipment with your color and affix the labels that you provide. Application specific features are easily incorporated.

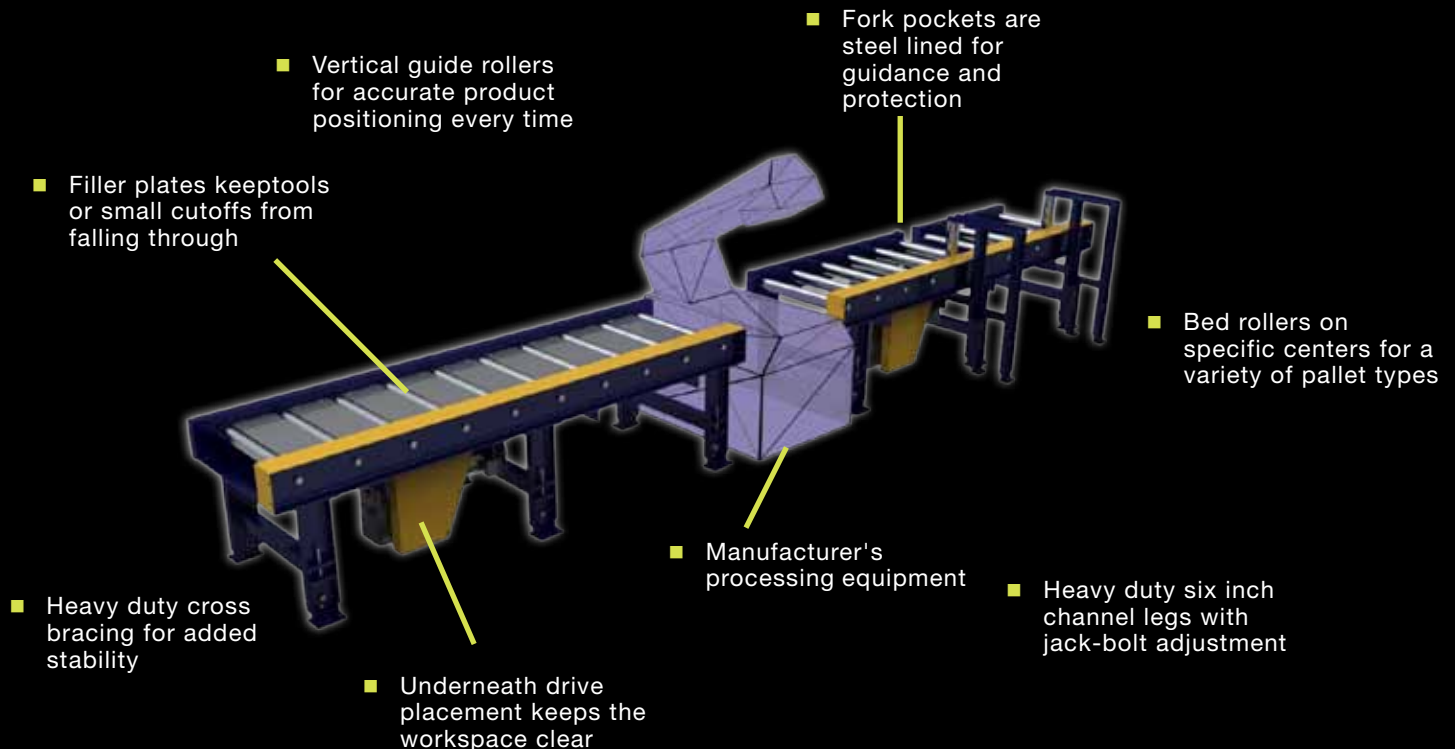

CUSTOM AGV CONVEYOR NO: 102

THE APPLICATION: AGV Decks

THE PRODUCT: Chain Driven Live Roller Conveyor

THE INDUSTRY: Automotive, Electronics, Food and Beverage, Paper and Printing, Pharmaceutical, Plastics, Textile, Distribution and Warehousing, Manufacturing

THE NEED: Egemin Automation Inc., a leading AGV manufacturer, needed custom fabrication to their AGV without the high costs of custom fabrication and the ability to private label

THE SOLUTION: Omni Metalcraft Corp. provided Egemin a pre-engineered Chain Driven Live Roller Conveyor with the custom modifications to suit the customer's needs. Customer specified motor, paint color, durability requirements, and many other custom features were provided at an economical price point.



LEVEL LIFT CHAIN TRANSFER NO: 103

THE APPLICATION: Complete ranges of packaging, drum, pallet, container, and tote applications.

THE PRODUCT: Level Lift Chain Transfer

THE INDUSTRY: Appliance, Oil, Paint, Chemical, Food, Beverage and other industries where spilling/sloshing needs to be avoided.

THE NEED: Manufacturers requiring 90° re-direction of heavy loads evenly and steadily onto adjacent conveyor.

THE SOLUTION: Omni Metalcraft Corp.'s level lift chain transfer introduces significant application flexibility and versatility to any material handling system. This innovative design utilizes a pneumatic cylinder to pivot the transfer carriage into the raised position. Exploiting the mechanical advantage of the pivot device, this unit uses less air than traditional air bag designs resulting in significant electricity savings over the life of the unit. The modular design of this unit also integrates easily with other equipment including: Chain Driven Live Roller, Pallet Accumulator, Gravity Roller Conveyor and Turntables.

Transfer Carriage

- Eliminate the rocking motion common with air bag designs. (tall products, liquids or other types of unstable loads)

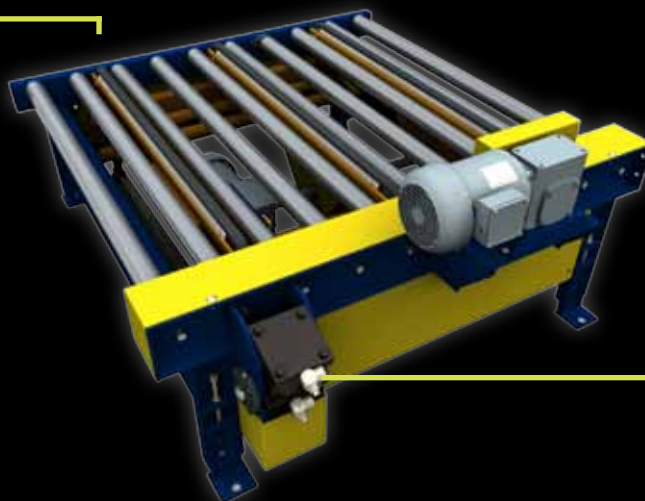

Multiple Configurations

- Lane-to-Lane
- Thru Frame
- Within Frame

Operation

- Transporting
- Accumulation
- Diverting
- Queuing
- Indexing
- Sorting

Pneumatic Cylinder

- Cylinder location provides easy access for installation and maintenance

STAINLESS STEEL TOTE HANDLING

NO: 104

THE APPLICATION: Stainless steel conveyors for bulk tote handling

THE PRODUCT: Stainless Steel Chain Driven Live Roller & Chain Transfer Conveyor

THE INDUSTRY: Food, Beverage, Pharmaceutical, Corrosive Industrial

THE NEED: A food manufacturer needed a washdown, heavy duty 90° transfer conveyor system for food product unloading.

THE SOLUTION: Omni Metalcraft Corp. can provide stainless steel, washdown rated Chain Driven Live Roller Conveyor with Chain Transfer Conveyor that extends beyond the conveying surface of the roller conveyor to accept fork truck loading.

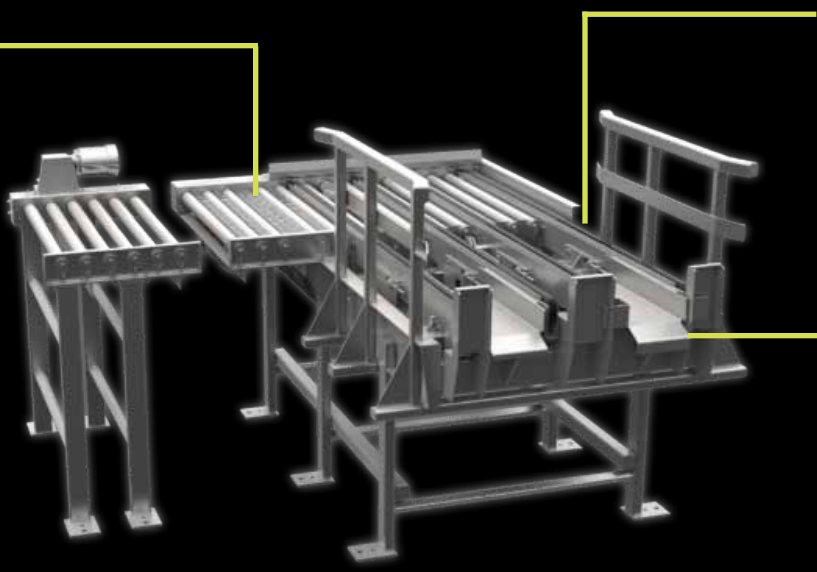
- 
- Stainless steel filler plates between rollers allow closer product access
 - Custom heavy duty tubular side guides assist fork truck loading operation
 - Washdown rated motors and reducers
 - High capacity external bearing rollers eliminate water and bacteria in tubing
 - Multi-strand corrosion resistant chain support, strength, and washdown application
 - 304 stainless steel frames, rollers, bearings and support structure
 - Guarding for fork truck loading of tote on the chain transfer
 - Heavy duty support structure

PNEUMATIC PULLER WITH CDLR NO: 105

THE APPLICATION: 90° transfer of products in packaging, drum, pallet, container, and tote applications.

THE PRODUCT: Pneumatic Puller

THE INDUSTRY: Appliance, Food, Beverage, Chemical, Battery

THE NEED: Manufacturers requiring 90° redirection of product, where other transfer devices cannot be utilized.

THE SOLUTION: Omni Metalcraft Corp. can provide a robust, but economical Pneumatic Puller on our Chain Driven Live Roller Conveyors. Our Pneumatic Puller is designed to “pull” the product to make a 90° change in direction. When a low maintenance, energy efficient transfer device is needed the Pneumatic Puller can be used as an alternative to a chain transfer or turntable.

- Puller “fingers” can be covered with protective materials

- Air cylinder actuated

- Roller side thrust protection available

- Adjustable guides can be provided for pallet positioning



- Puller engineered to suit the application

- Valving and controls can be provided to suit the application

- Integrated with out-feed gravity or powered conveyor

PALLET PACKER STATION WITH CDLR NO: 106

THE APPLICATION: Powered discharge conveyor with provisions for lift frame from destacker

THE PRODUCT: Chain Driven Live Roller Conveyor

THE INDUSTRY: Industrial Steel

THE NEED: Manufacturer required powered discharge conveyor for sheet steel destacker to replace current gravity conveyor that was not providing an ideal solution.

THE SOLUTION: Omni Metalcraft Corp. provided specially designed chain driven live roller conveyor to replace the manual gravity conveyor. The chain driven live roller conveyor was built to the customer's specifications for easy integration with existing equipment.

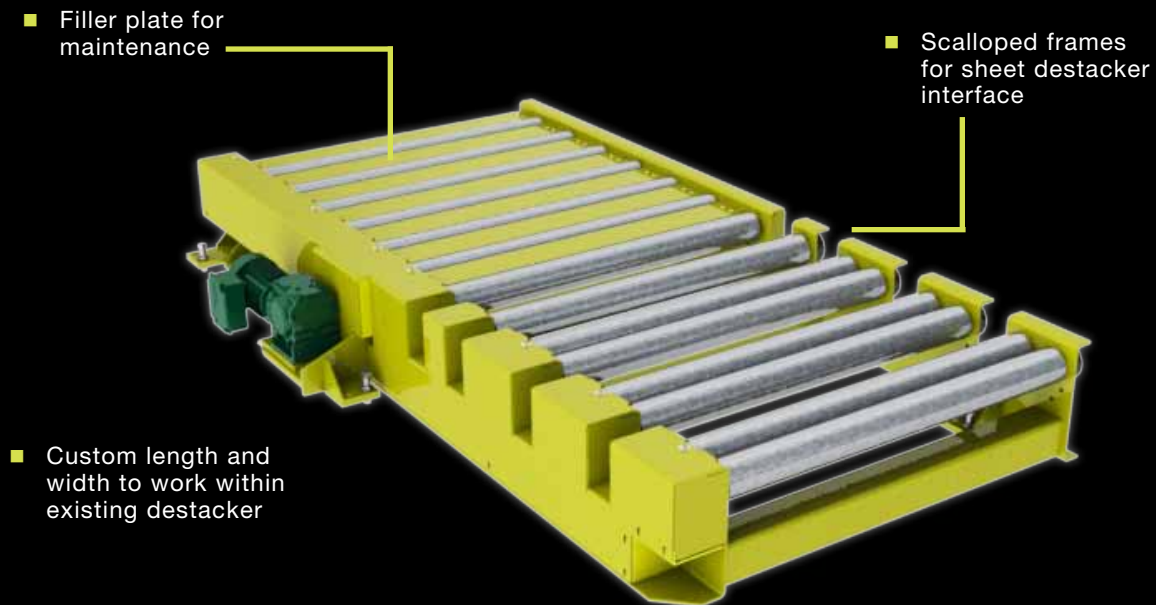

TUBE SORTER WITH CDLR NO: 107

THE APPLICATION: Saw line discharge conveyor for tube manufacturing

THE PRODUCT: Chain Driven Live Roller Conveyor with Product Kickoff Arms

THE INDUSTRY: Metal Manufacturing

THE NEED: Automatically sort and discharge defective tubes.

THE SOLUTION: Omni Metalcraft Corp. provided a robust tube handling conveyor consisting of concave rollers and specially designed kick off arms. These arms were designed to discharge defective tube off of one side and acceptable tube off of the other side. This eliminated the use of overhead cranes and reduced manpower in handling.



- Specially designed kick off arms for sortation



- Concave rollers for tube cradling



TUBE HANDLING CDLR LIFT GATE NO: 108



■ 1/4" thick concave urethane coating

THE APPLICATION: Transporting tube in a cutting operation over a walkway

THE PRODUCT: Concave Roller Chain Driven Live Roller Conveyor with Lift Gate

THE INDUSTRY: Metal Manufacturing

THE NEED: A metal tube fabricator was expanding their operations and needed a conveyor to transport and center the tube for cutting it to length. The tube was in the final stages of processing so a heavy duty coated surface was needed to protect its finish. A lift gate was also needed to allow operators, fork trucks, and carts to pass thru the processing area.

THE SOLUTION: Omni Metalcraft Corp. designed a Chain Driven Live Roller Conveyor with concave shaped rollers and a heavy duty concave urethane coating. The coated rollers not only protects the tube finish but also accurately centers it for the saw cut off operation. The lift gate is hydraulically actuated to avoid operators from a manual lifting interface.

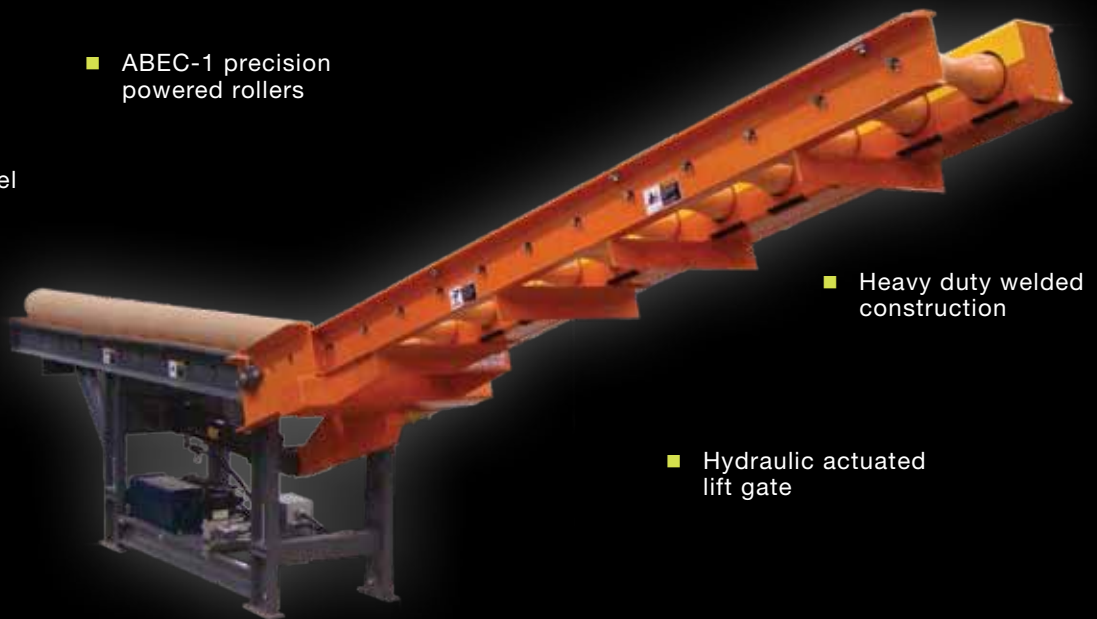

■ ABEC-1 precision powered rollers

■ Concave formed steel rollers

■ Heavy duty welded construction

■ Structural channel frames

■ Hydraulic actuated lift gate

PACK-OUT STATION NO: 109

THE APPLICATION: Robotic crate loading

THE PRODUCT: Zero Pressure Chain Driven Live Roller Conveyor Pack-Out Station

THE INDUSTRY: Plastics

THE NEED: A customer needed to load crates of product via a robot located on the side of the conveyor and unload empty crates in the smallest footprint feasible. The crates needed to be located in multiple positions because they were two layers deep, two rows wide and needed to be specifically located for robot loading of each layer and each row at a time.

THE SOLUTION: Omni Metalcraft Corp. designed a Pack-Out Station consisting of two lanes of zero pressure accumulation chain driven live roller conveyor. The first lane accepted empty crates from a fork truck, the lane accumulated and fed the first alignment section. The crates were stopped by a rotating blade stop, aligned with a crowder where row one of layer one was loaded. The same action was repeated when the crate moved to the next blade stop and crowder. Once the first layer was completed, the crate reversed to repeat the same actions for the second layer. Once completely full the crate was transferred to the adjacent lane to be removed.

- Ultrasonic forklift detection at the load and unload ends

- Load deflectors and safety endstops

- Custom side robot interface location

- Zero Pressure accumulation in and out

- Lane to lane pop-up chain transfer

- Pallet crowder at robot interface station

- Rotating bladestops to save space



HEAVY DUTY STAINLESS STEEL CONVEYOR NO: 110



Gravity Roller Conveyor

THE APPLICATION: Handling large totes, drums and palletized loads in a washdown environment

THE PRODUCT: Stainless Steel Chain Driven Live Roller Conveyor and Gravity Roller Conveyor

THE INDUSTRY: Food Manufacturing

THE NEED: A food manufacturer needed to transport totes, drums and palletized loads weighing 2500 lbs or more.

THE SOLUTION: Omni Metalcraft Corp. provided Heavy Duty CDLR and Gravity Roller Conveyor with stainless steel materials and washdown duty components. The conveyor was designed to withstand heavy loads as well as meet the customer's washdown design criteria.

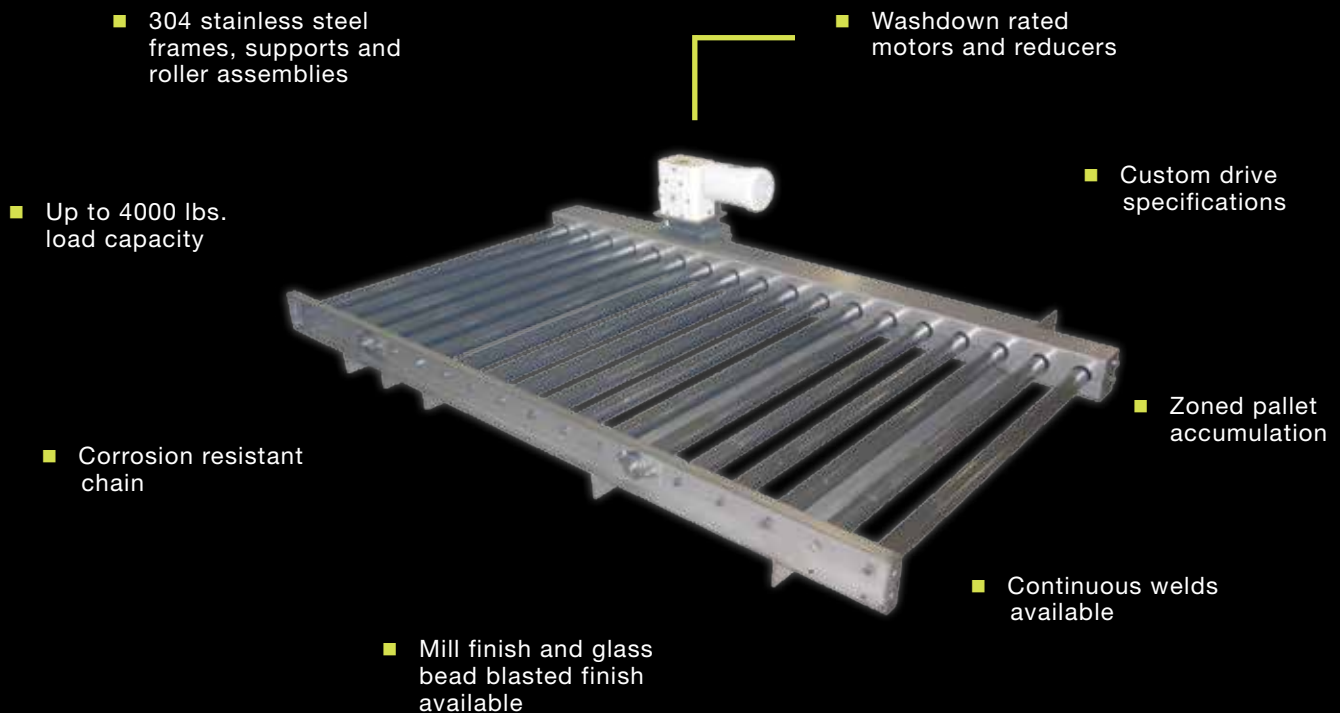

ADJUSTABLE CHAIN CONVEYOR NO: 111



■ Strand shown adjusted to 14" center

THE APPLICATION: Transporting multiple size products with varied surfaces

THE PRODUCT: Adjustable Rail Chain Conveyor

THE INDUSTRY: Sheet Metal Manufacturing

THE NEED: A sheet metal fabricator needed a conveyor with an open design to accommodate components that were not flat and would adjust to different component widths. The current conveyor they had in place required tools to adjust the rail which was timely and costly. The conveyor design had to interface within existing equipment parameters.

THE SOLUTION: Omni Metalcraft Corp. worked with the customer's existing design to develop an Adjustable Rail Chain Conveyor with clamps for easy locking and unlocking. The conveyor was equipped with a v-track for guidance making rail positioning quick and easy.



CUSTOM SAW FEEDING EQUIPMENT NO: 112

THE APPLICATION: Steel bar unloading and saw infeed

THE PRODUCT: Pneumatic Chain Transfer and Gravity Roller Conveyor

THE INDUSTRY: Forging

THE NEED: A manufacturer of metal cutting saws needed a conveyor embedded into their unloading table that could receive singulated 20 foot long x 6 inch diameter steel bars from an unbundler.

THE SOLUTION: Omni Metalcraft Corp. designed a custom saw feeding equipment solution consisting of a Chain Transfer with chain lugs and a Gravity Roller Infeed Conveyor. The Chain Transfer was designed to pneumatically pop up to create a horizontal carrying surface. The lugs would grab bars of steel and convey them to the embedded gravity roller conveyor. Once the bar reached the gravity conveyor, the end of the transfer would then tilt down to allow the bar to set onto the conveyor. The saw clamping head would automatically grab the bar and feed it to the cutting operation.

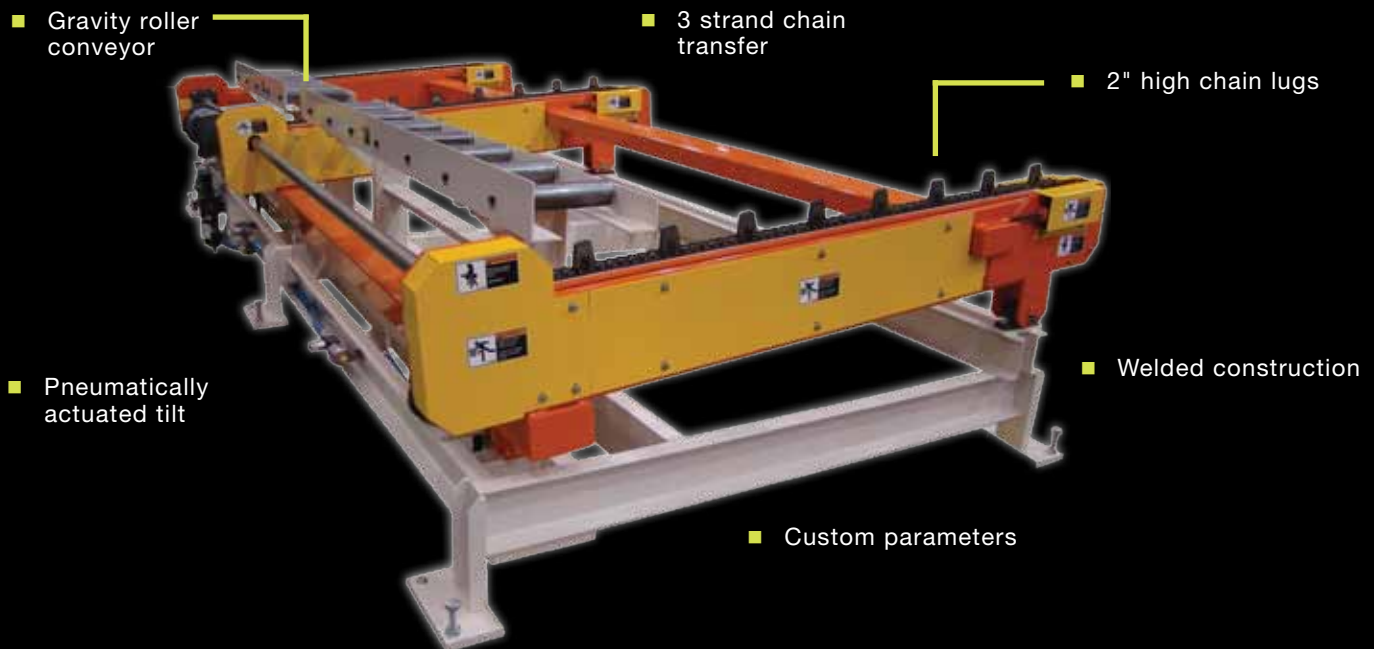

ROTOR TURNOVER NO: 113

THE APPLICATION: Rotor Machining and Drilling

THE PRODUCT: Padded Chain Conveyor, Chain Driven Live Roller Conveyor and Pneumatic Turnover Device

THE INDUSTRY: Automotive

THE NEED: A rotor manufacturer was adding machining lines to their facility. Rotors needed to be turned over so they could be drilled and machined on both sides.

THE SOLUTION: Omni Metalcraft Corp. provided a Powered Rotor Turnover Device with an Internal Chain Conveyor. The rotors conveyed top-down on a short length of Chain Driven Live Roller Conveyor equipped with Ultrex Sleeves. The rotors were accumulated by using pneumatic pin stops and then conveyed into the Rotor Turnover. This pneumatic-actuated device turned the rotors over onto padded chain conveyor so machining and drilling could be completed.

■ Pneumatic pin stop



■ Ultrex sleeves

■ Pneumatic actuated turnover device

■ Infeed and outfeed chain driven live roller conveyor

■ Padded chain conveyor



PICK AND PLACE ROBOTIC PALLETIZER NO: 114

THE APPLICATION: Pick and Place Robotic Palletizer for Variable Height Palletizing

THE PRODUCT: Three Strand Chain Conveyor and Multi-Tier Scissor Lift with Integral Chain Conveyor

THE INDUSTRY: Parcel

THE NEED: A Canadian postal service company needed to robotically palletize bundles of magazines. Three different pallets with unique footprints needed to be conveyed.

THE SOLUTION: Omni Metalcraft Corp. provided an infeed three strand chain conveyor to receive empty pallets. A triple strand chain conveyor created better surface area allowing all three styles of pallets to be conveyed. Pallets were conveyed onto a Multi-Tier Scissor Lift with chain conveyor mounted to it. The lift lowered as the robot completed a layer. As the full pallet descended it would be stretch wrapped and then conveyed onto a buffering section of chain conveyor allowing for the fork lift operator flexibility.

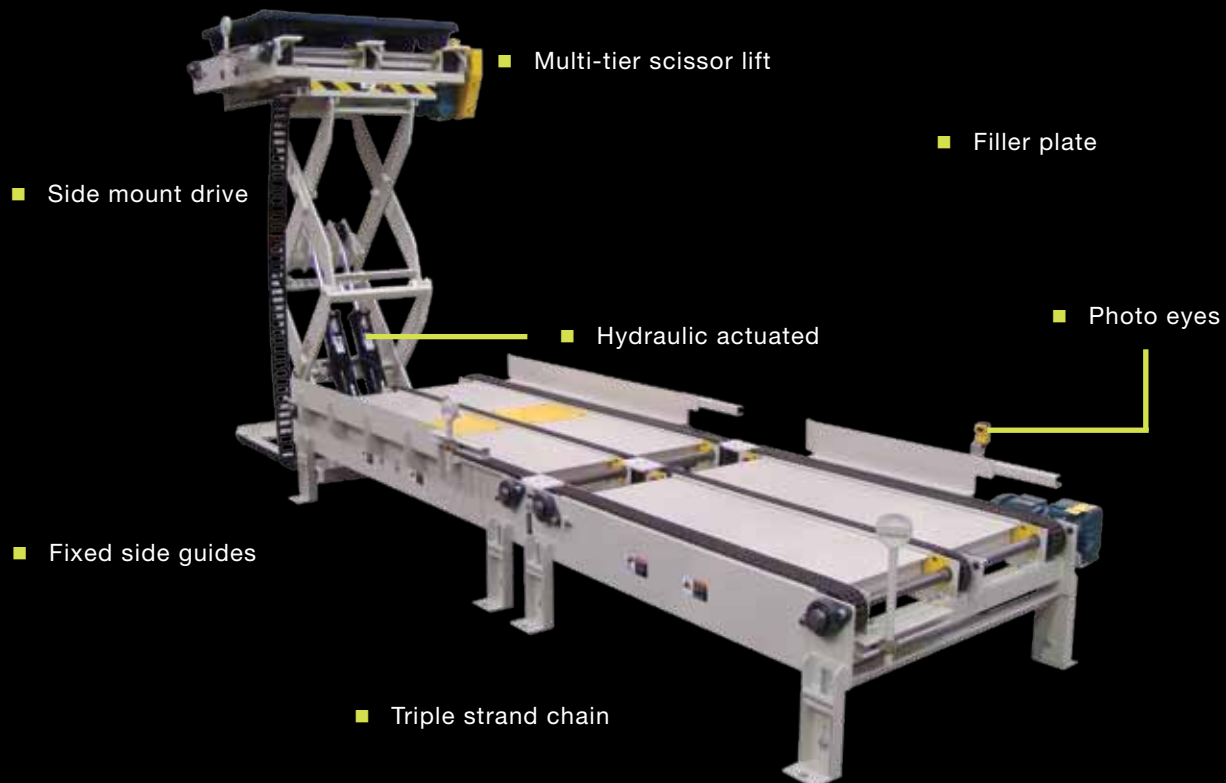

FOUNDRY LIFT GATE

NO: 115

THE APPLICATION: Creating Access within a Foundry Mold System

THE PRODUCT: Draw Bridge Lift Gate, Chain Driven Live Roller Conveyor and Chain Transfers

THE INDUSTRY: Foundry

THE NEED: A foundry needed to provide access to the inside of a closed loop system.

THE SOLUTION: Omni Metalcraft Corp. provided a heavy duty Chain Driven Live Roller Conveyor with a Lift Gate and a Seven Strand Chain Transfer on either side of the gate. The lift gate and chain driven live roller conveyor were of heavy duty construction with provisions to withstand the harsh foundry environment. The draw bridge style lift gate was designed to be lifted utilizing an existing ceiling mounted crane.



- Foundry provisions
- Heavy duty 3 1/2" diameter rollers
- Draw bridge lift gate
- 3500 lb. capacity
- 7 strand chain conveyor

T-CAR WITH TRAVERSING CDLR DECK

NO: 201

THE APPLICATION: Horizontal movement of heavy duty racks holding axles

THE PRODUCT: Transfer Car with Traversing Chain Driven Live Roller Deck

THE INDUSTRY: Tractor and Utility Equipment Manufacturer

THE NEED: A manufacturer needed to move heavy duty axles for tractors and utility vehicles. The T-Car was servicing multiple lanes of conveyor, however due to a pillar obstruction, the axles could not be loaded and conveyed in a straight horizontal line.

THE SOLUTION: Omni Metalcraft Corp. designed a dual lane CDLR (Chain Driven Live Roller) that extended out for loading of the axles into a footed rack and then retracted to clear the obstruction for servicing of multiple conveyor lanes. The welded structural framework was mounted on a transfer car and equipped with drip pans to keep the area below clean.

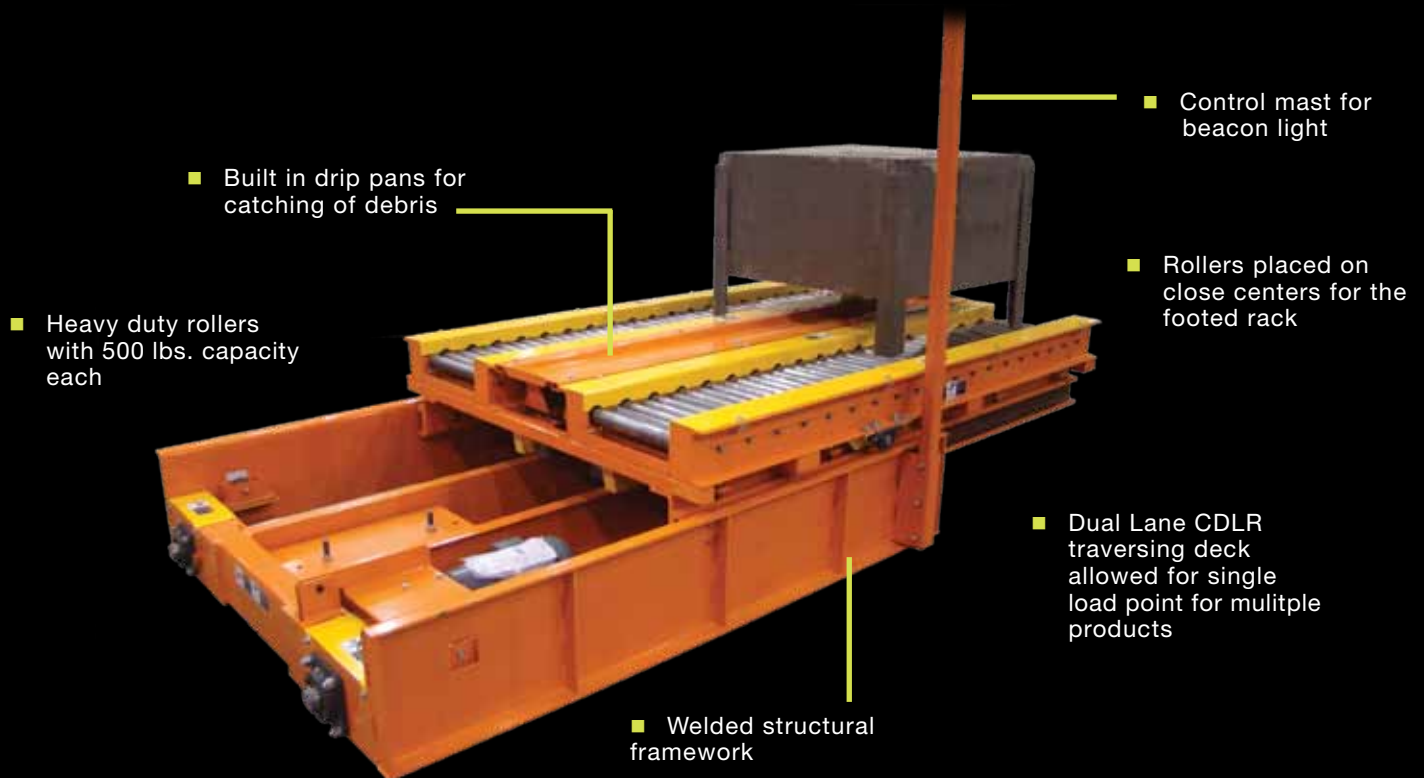

VERTICAL LIFT ARM CHAIN CONVEYOR NO: 202

THE APPLICATION: Lift product up and into shipment rack

THE PRODUCT: Vertical Lift Arm Chain Conveyor

THE INDUSTRY: Textile Fabrication

THE NEED: A Textile Fabricator needed an economic solution that utilized a small footprint to lift and load packaged rolls into a shipping rack. A fork truck operator would wait and load each roll into shipping racks as they reached the end of the conveyor line.

THE SOLUTION: Omni Metalcraft Corp. provided a custom Vertical Lift Arm Chain Conveyor that automatically loaded the shipping rack with the packaged rolls. A right and left hand Vertical Lift Arm Chain Conveyor was provided for each side of the tilting belt conveyor allowing two shipping racks to be filled simultaneously.

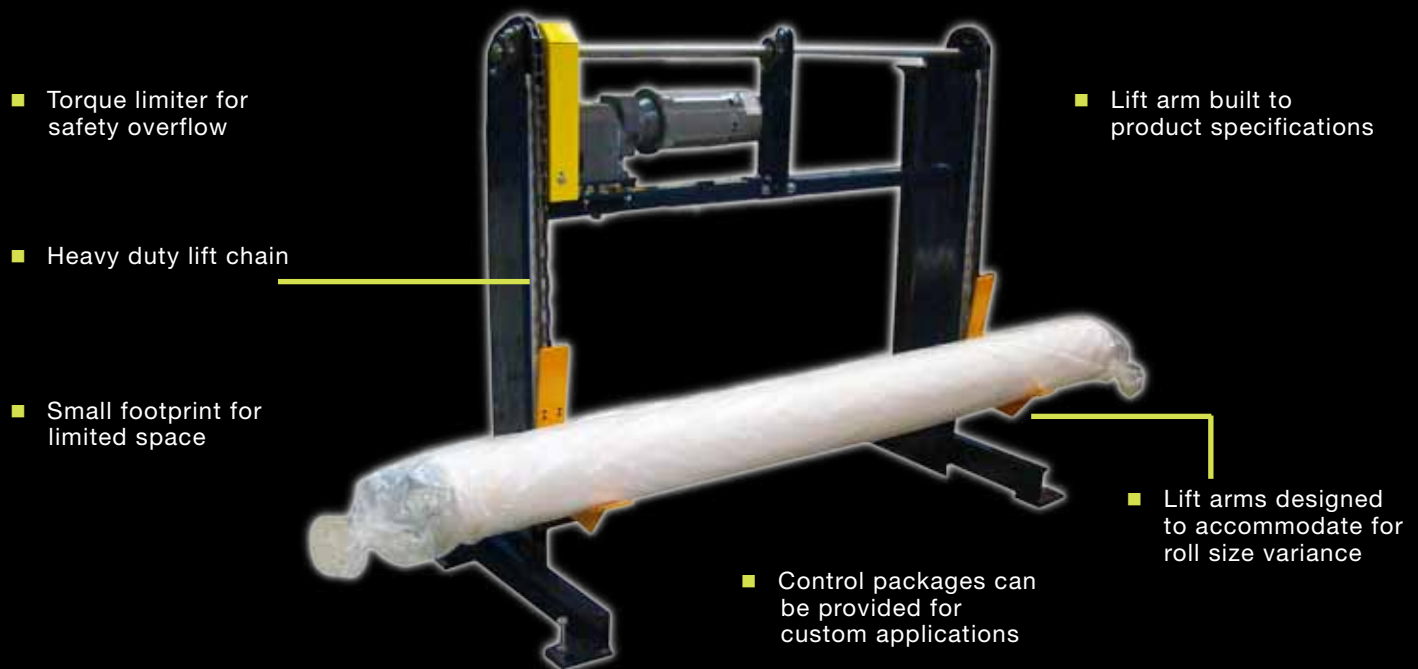

PIVOT BELT CONVEYOR

NO: 203

THE APPLICATION: Transporting sand molds in a foundry around tight corners and existing equipment while maintaining product orientation

THE PRODUCT: Pivot Belt Conveyor

THE INDUSTRY: Foundry

THE NEED: A manufacturer needed to transport sand molds in a harsh foundry environment. The conveyor needed to maneuver a tight corner around existing machine and withstand the demands of the abusive environment.

THE SOLUTION: Omni Metalcraft Corp. provided a Belt Conveyor on a Pivot Deck that transported the molds around the existing machine utilizing a small footprint. The robust Pivot Conveyor turned 90° while maintaining product orientation in the space allotted utilizing less space than a standard belt curve.

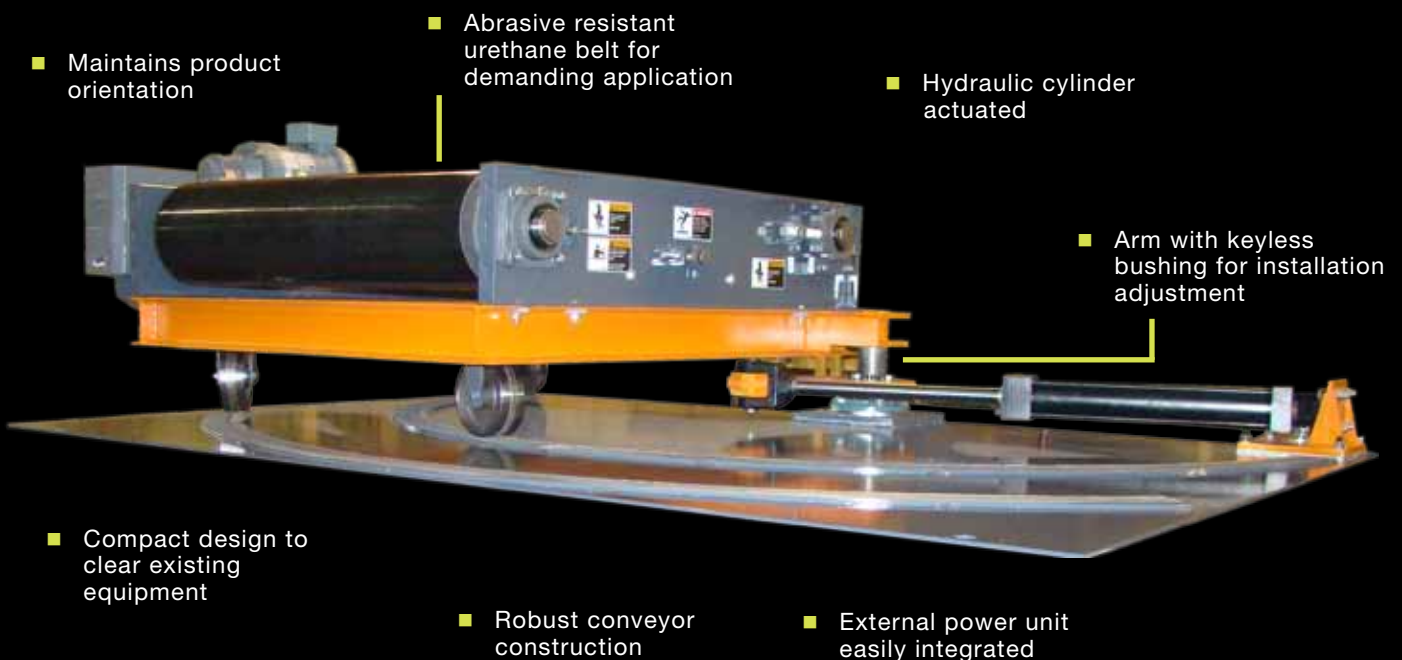

ROBOTIC CRATE FILLING STATIONS

NO: 204

THE APPLICATION: Robotically filling crates with multiple sizes and types of glass components

THE PRODUCT: Tilters with Plastic Belt Conveyor and Zoned Chain Driven Live Roller Conveyor

THE INDUSTRY: Glass Manufacturing

THE NEED: Glass oven tops and doors needed to be crated after manufacture. Prior to loading the glass, a foam insert needed to be placed on the bottom of the crate by an operator. A robot would then stack the glass in the crate. When the crate was full an operator would then top the glass stack with another foam insert. The conveyor needed to maintain the appropriate throughput and handle various combinations of crate sizes, types and orientation.

THE SOLUTION: Omni Metalcraft Corp. provided a pit mounted crate handling CDLR with two tilting stations. A pallet jack could load the crate onto the infeed tilter that would be tilted to approximately 45° to allow an operator to place the foam insert. To save on throughput, the CDLR remained angled and the crate was conveyed to the robotic loading station. Upon filling it went to the outfeed tilter where an operator topped the crate with a foam insert. Here the full crate was returned to a neutral position and picked up by a pallet jack.



PALLET DESTACKER WITH CDLR NO: 205

THE APPLICATION: Pallet dispensing and building

THE PRODUCT: Pallet Destacker Integrated with Chain Conveyor, Chain Driven Live Roller Conveyor

THE INDUSTRY: Plastic Manufacturing

THE NEED: The ability to store, dispense, stage and build pallets.

THE SOLUTION: Omni Metalcraft Corp. integrated a pallet destacker with integral chain conveyor to dispense single pallets onto a chain driven live roller conveyor. The pallet was then outfitted with a glued box which was guided utilizing an adjustable product guide rail. The box was stopped with a pop-up blade stop to be filled with plastic pellets.

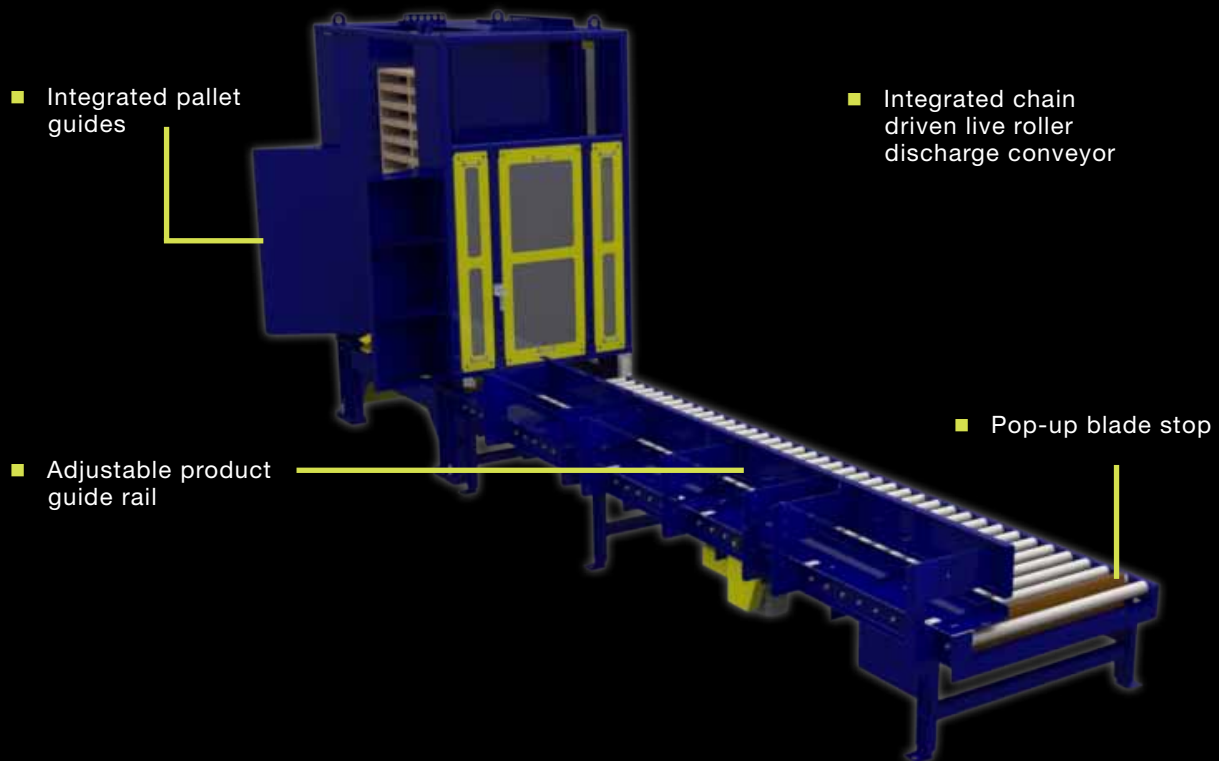

AUTOMOTIVE GLASS INSPECTION TURNTABLE NO: 206

THE APPLICATION: Automotive Glass Inspection, Trimming and Assembly

THE PRODUCT: Powered Turntable with Inspection Fixtures

THE INDUSTRY: Automotive Glass

THE NEED: An automotive glass manufacturer needed an equipment solution to eliminate workers from manually having to move windshield glass from station to station for inspection, trimming and assembly.

THE SOLUTION: Omni Metalcraft Corp. provided a large turntable with four workstations allowing the workers to stay in place and perform their operation on each piece of glass with ergonomics and efficiency in mind. Each station is equipped with urethane covered supports allowing a worker to stand the windshield upright for visual inspection without damaging the glass. Each station also included a pneumatically actuated suction cup used to raise, lower and rotate the glass for inspection, trimming and the adding of additional components.

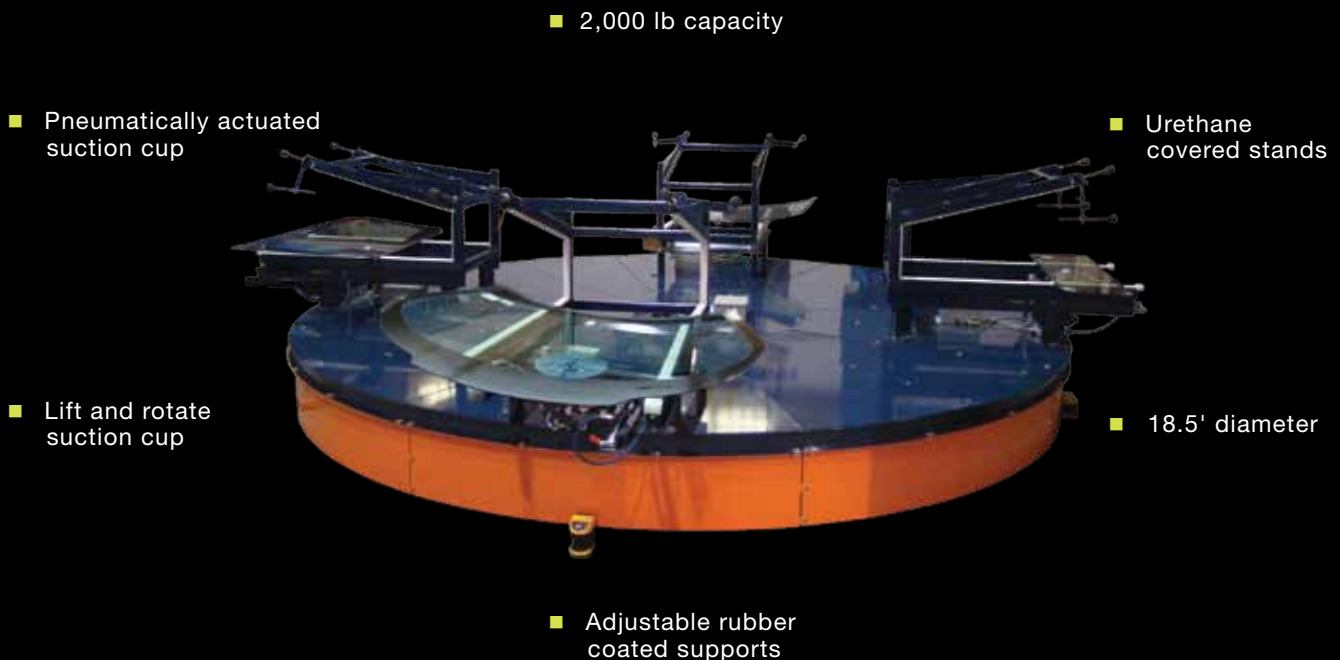

SEAT PALLET STACKER NO: 207

THE APPLICATION: Empty Seat Pallet Stacking

THE PRODUCT: Gravity Roller Conveyor, Chain Conveyor and Pallet Stacker

THE INDUSTRY: Automotive

THE NEED: An automotive manufacturer needed to put in a new line to receive, stack and convey empty seat pallets out to the fork truck operator.

THE SOLUTION: Omni Metalcraft Corp. provided a two strand Chain Conveyor to receive empty pallets. The pallets accumulated prior to entering the stacker, where they were stacked one at a time. After stacking, the Chain Conveyor was reversed and the pallets were transported onto Gravity Roller Conveyor. The Gravity Roller Conveyor was mounted to a pneumatically actuated unit that tipped the stack towards the fork truck operator for ease of loading.

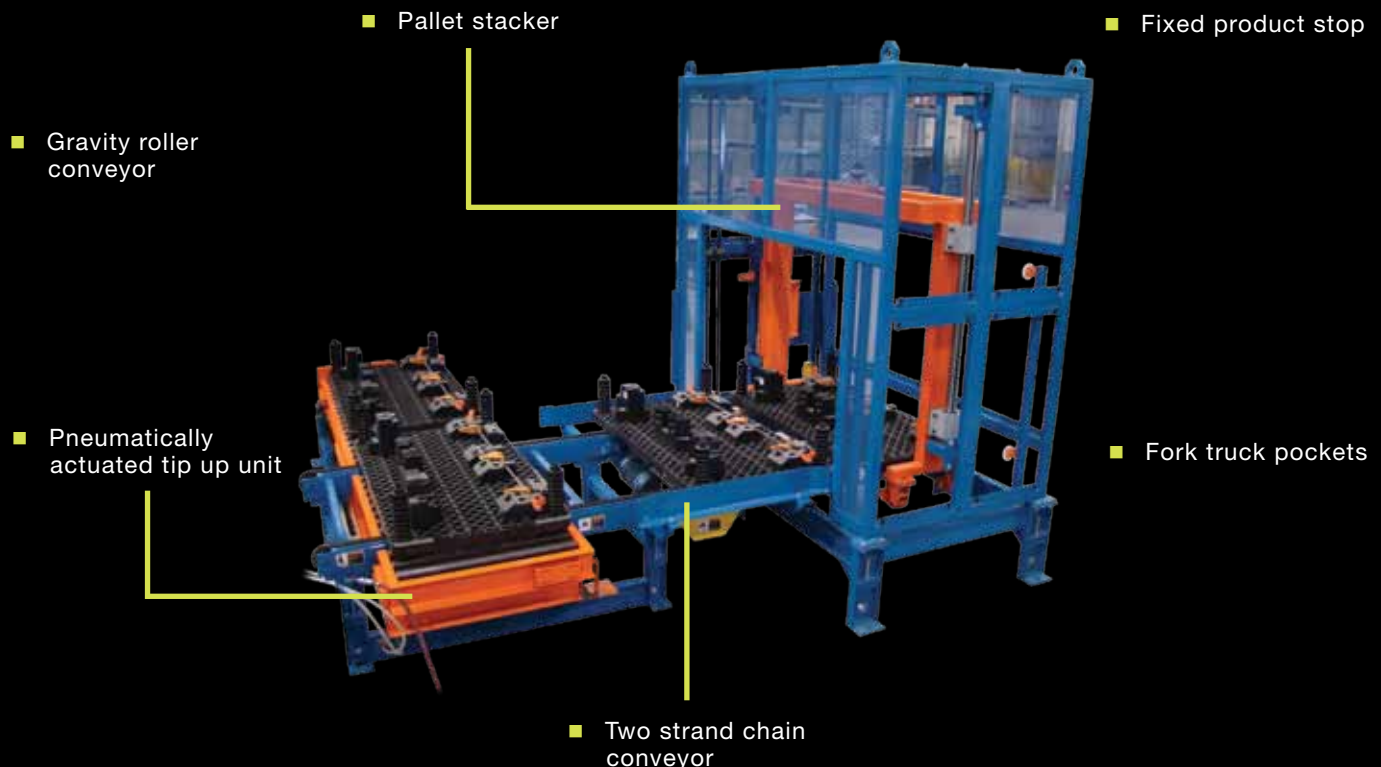

HEAVY DUTY ROLL HANDLING TURNTABLE NO: 208

THE APPLICATION: Conveying Large Rolls of Tissue Paper Product

THE PRODUCT: Infeed and Discharge Chain Driven Live Roller Conveyor and Custom Turntable with Integral Chain Driven Live Roller Conveyor

THE INDUSTRY: Paper

THE NEED: A tissue paper manufacturer was installing a new line into an existing facility. They needed a system of conveyors that would transport various sized rolls up to 12,000 lbs. The conveyors needed to integrate with additional equipment provided by other OEMs.

THE SOLUTION: Omni Metalcraft Corp. provided Heavy Duty Chain Driven Live Roller Conveyor feeding and discharging a large diameter Turntable for transitioning various sized rolls 90 degrees. The system started at the lower level of the facility conveying raw rolls of tissue into a Reciprocating Vertical Conveyor, outfitted with Omni CDLR mounted integral. The roll was then transitioned to the second level, conveyed into a stretch wrapper and out to shipping.

■ Welded construction

■ 12 inch roller centers

■ Precision drive rollers

■ Customer specifications

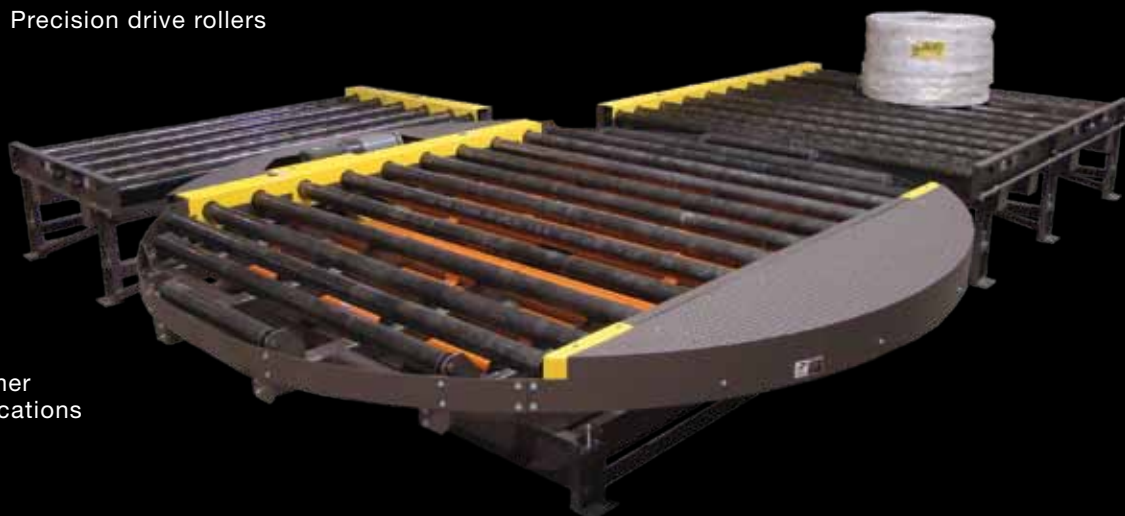

TRANSFERRING EMPTY PALLETS

NO: 209

THE APPLICATION: Transferring Empty Pallets for Cylinder Remanufacturing

THE PRODUCT: Powered Transfer Car with Chain Driven Live Roller Conveyor

THE INDUSTRY: Agricultural Equipment and Machinery Manufacturing

THE NEED: An agricultural machinery manufacturer needed to reduce manual labor and create a more efficient system of transferring empty pallets for reuse.

THE SOLUTION: Omni Metalcraft Corp. provided Chain Driven Live Roller Conveyor mounted on top of a Powered Transfer Car to transport empty steel pallets. An operator would load a cylinder head onto the pallet, complete the required prep work and release the cylinder for further processing down a line of CDLR onto another transfer car at the end.

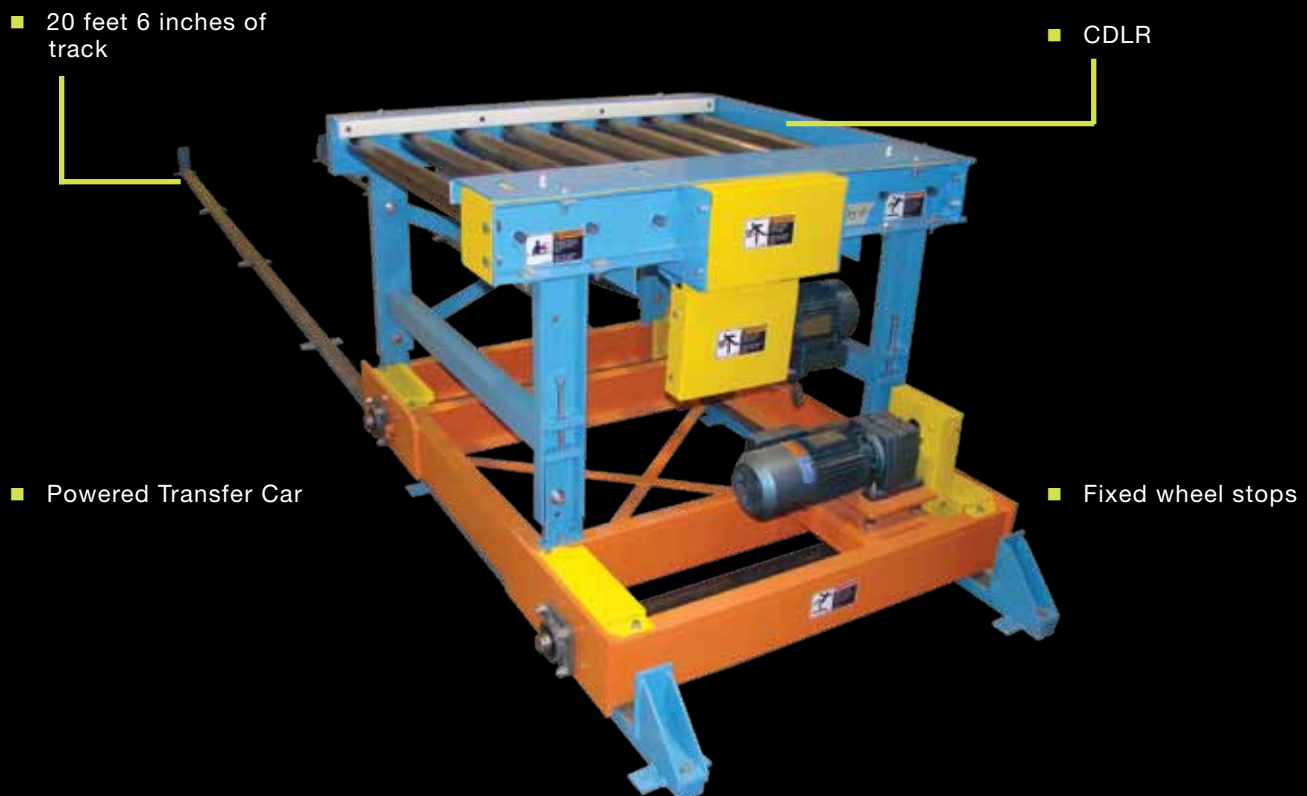

FOUNDRY SAND MOLD SHAKE OUT STATION NO: 210

THE APPLICATION: Transferring Sand Molds from the Main Line to Filling and Dumping Workstations

THE PRODUCT: Tilter with Chain Driven Live Roller Conveyor and a Hydraulic Scissor Lift Mounted to a Powered Transfer Car

THE INDUSTRY: Foundry

THE NEED: A castings manufacturer was installing a new cope and drag line that needed to stand up to a harsh foundry environment. The line was transporting metal pallets carrying molds that needed to be transferred to a shake out station which required lifting and tilting the mold.

THE SOLUTION: Omni Metalcraft Corp. provided a Powered Transfer Car with a Lift and Tilt that would transfer the mold to the workstation, adjust to the correct height and allow the mold to be transferred off onto the shake out station. A rotating end stop would keep the pallet on the conveyor allowing just the mold to move.



HELIX LINESHAFT CONVEYOR NO: 301

THE APPLICATION: Changing Product Angle for Ergonomic Loading

THE PRODUCT: Helix Lineshaft Conveyor

THE INDUSTRY: Paper Goods

THE NEED: A wrapping paper manufacturer needed to replace an existing conveyor line that would change the product angle. The manufacturer needed to load rolls of wrapping paper into a 40 1/2" tall box at an ergonomic loading angle and turn the box into an upright standing position for taping.

THE SOLUTION: Omni Metalcraft Corp. worked with the customer's need to develop a Helix Lineshaft Conveyor that would utilize conveyor movement and a helixed design roller bed to change the orientation of the box. The tall box would be filled at an ergonomic 45 degree angle, then turned upright utilizing the helix lineshaft conveyor.

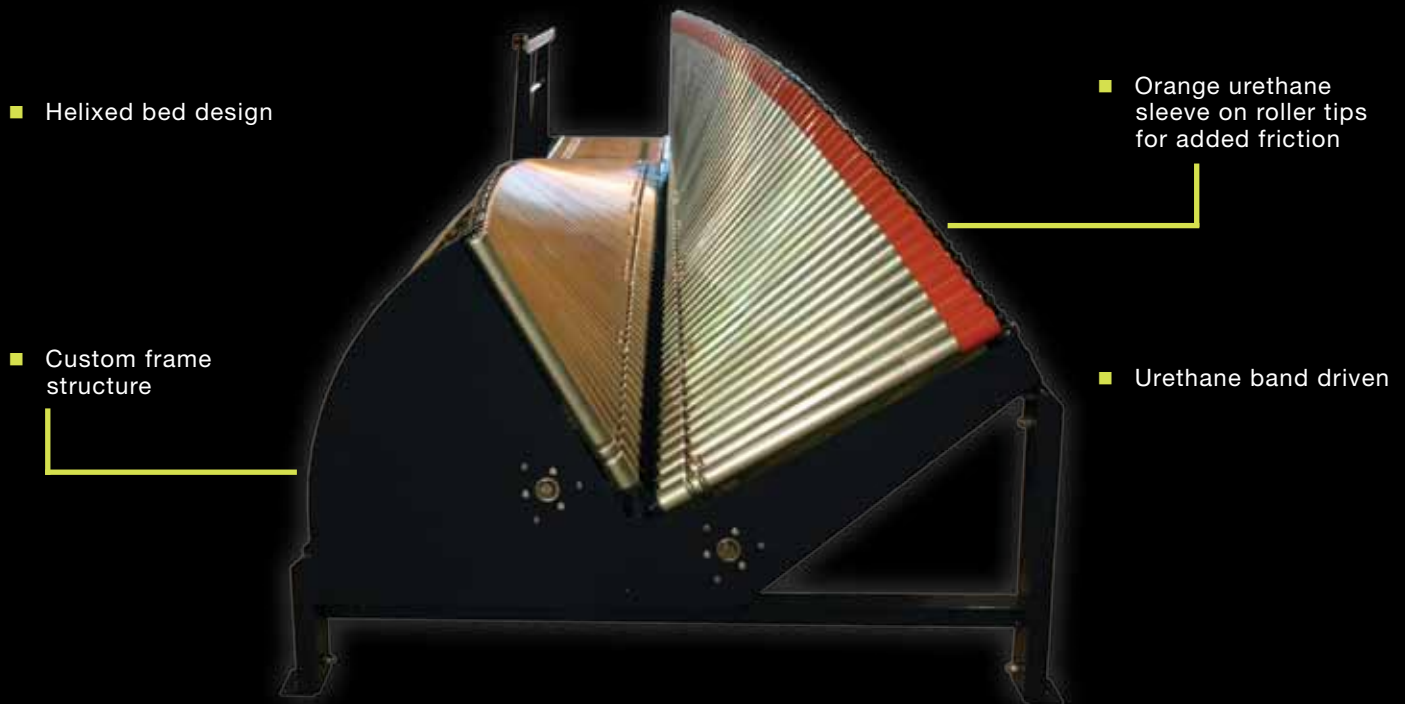

3 TIER GLASS HANDLING & STORAGE MDR NO: 302



THE APPLICATION: First In-First Out Glass Storage and Buffer Operation

THE PRODUCT: Three Tier Motor Driven Roller Conveyor Integrated with Two Reciprocating Vertical Lifts with Dual Conveyor Decks

THE INDUSTRY: Glass Manufacturing

THE NEED: A glass oven top manufacturer needed a new solution for a line expansion. The manufacturer needed to create a significant amount of storage space while using minimal floor space as well as provide a first in-first out buffer for the robot. It was Omni Metalcraft Corp.'s job to ensure the glass was handled gently without marking or marring it. It was also important that it was simple for the integrator to install utilizing plug and play accumulation controls.

THE SOLUTION: Omni designed a custom three tier motor driven roller conveyor integrating two reciprocating vertical conveyors creating three levels of "buffering." Each layer was zoned for zero pressure accumulation and equipped with customer supplied specific glass handling photo eye sensors. The rollers were slave driven by urethane bands allowing for smooth transportation and a non-marring surface.

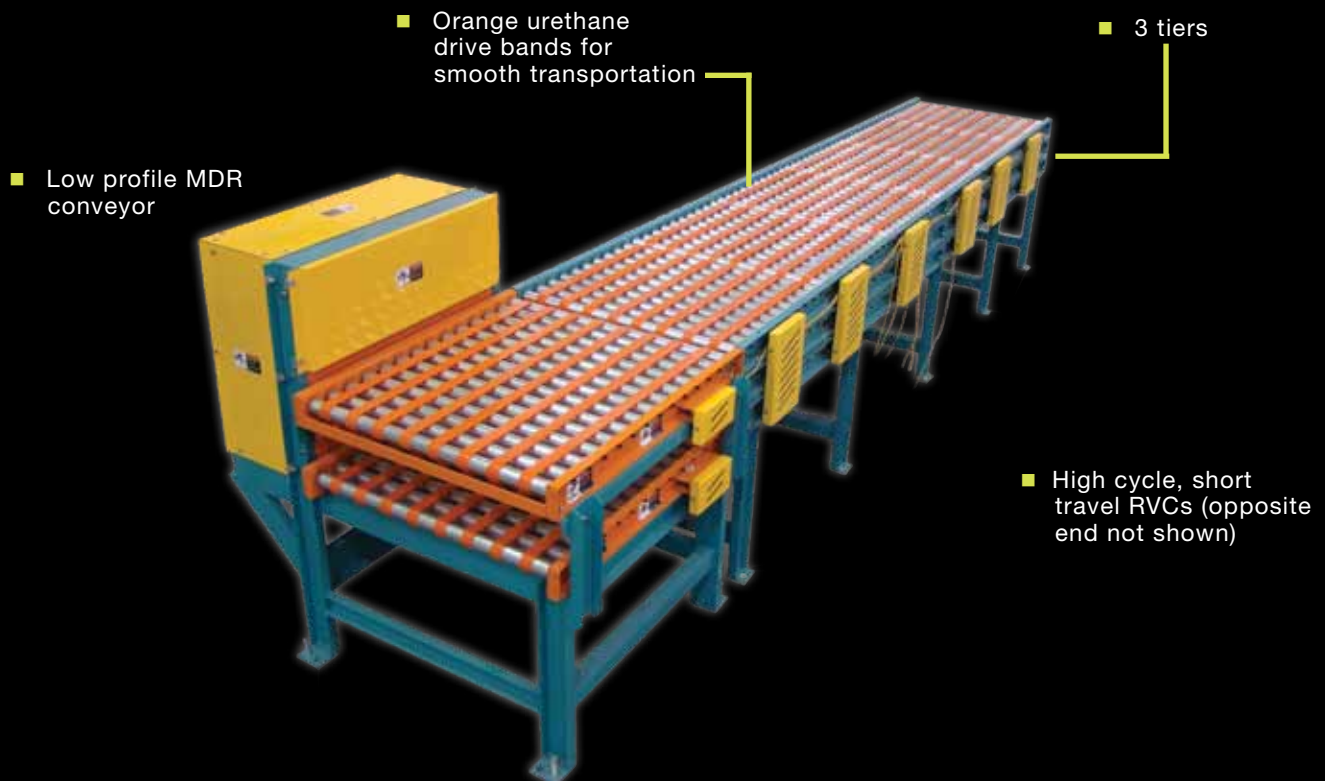

FLAT MOTOR ZPA

NO: 303

THE APPLICATION: Zoned Product Accumulation

THE PRODUCT: Flat Motor Driven Roller Conveyor

THE INDUSTRY: Consumable Goods

THE NEED: A household cleaner manufacturer needed to replace a dysfunctional accumulating conveyor. Their current conveyor allowed products to feed into the palletizer when it was not ready, causing the system to jam.

THE SOLUTION: Omni Metalcraft Corp. designed a system utilizing 24 Volt Flat Motor Driven Roller Conveyor for zero pressure accumulation. The flat motor conveyor provided an affordable solution that was clean in design and quiet while in operation. Omni pre-wired the conveyor, cutting installation time in half and saving the customer money and hassle.

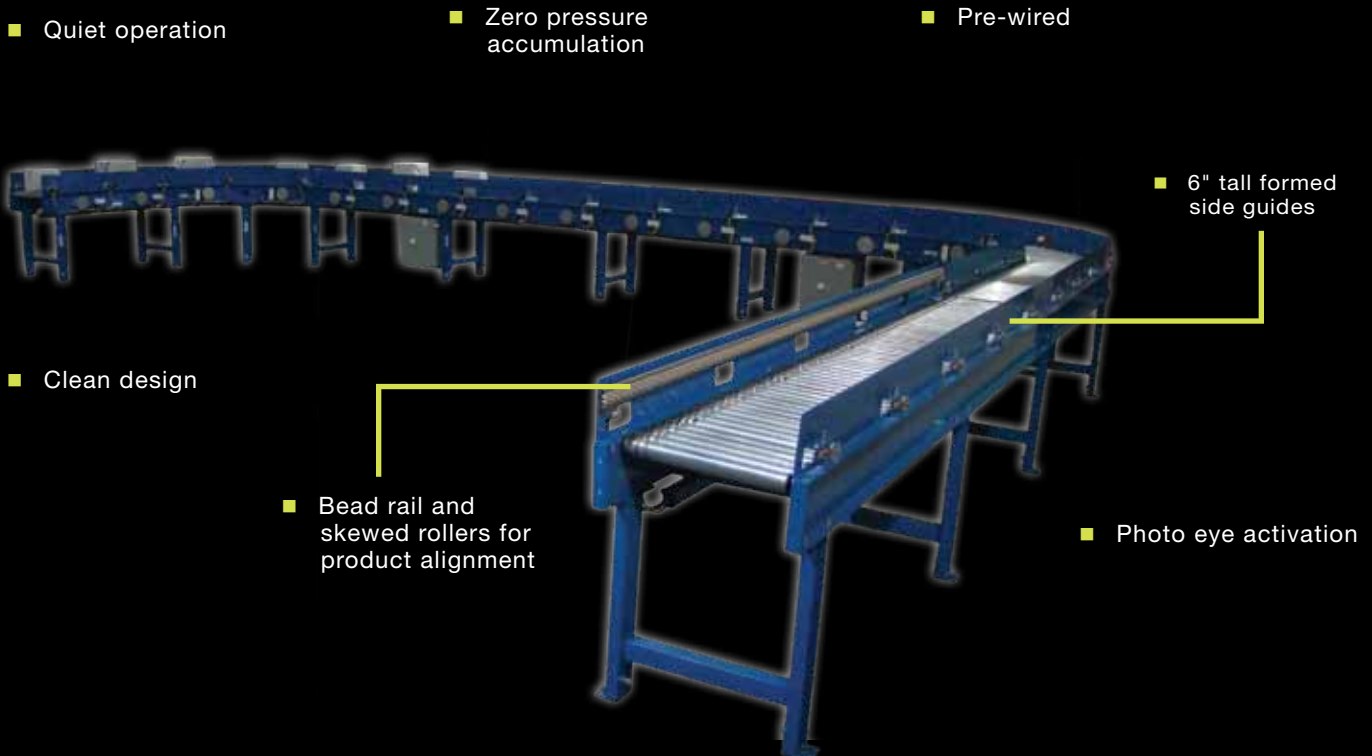

MDR BATTERY STORAGE SYSTEM

NO: 304

THE APPLICATION: Storage

THE PRODUCT: Zero Pressure Motor Driven Roller Conveyor, Chain Transfers and Chain Driven Live Roller Conveyor Mounted to Scissor Lifts on Transfer Cars

THE INDUSTRY: Battery

THE NEED: An expanding battery manufacturer needed an automated cell to assemble batteries. After assembly, the batteries needed to be gently placed into a storage area for their cure time. The battery was then brought out of storage in proper sequence and placed back into the assembly line. The system design needed to be reliable, compact and able to convey 350 lb batteries.

THE SOLUTION: Omni Metalcraft Corp. worked with an integrator to design a dual tier, four lane wide, compact, yet heavy duty Motor Driven Roller Conveyor system. Batteries were assembled and placed on a pallet by a robot. The pallet was then positioned utilizing a crowder. The pallet was then transferred to a conveyor mounted to a scissor lift on a transfer car that moved the battery to the correct storage level and lane for the curing process. As batteries were added, they were accumulated on ZP MDR and conveyed to the last zone for pick up. The entire system was built in modular sections and wired for easy set-up and assembly. Device Net modules were used to give the plant full system visibility.

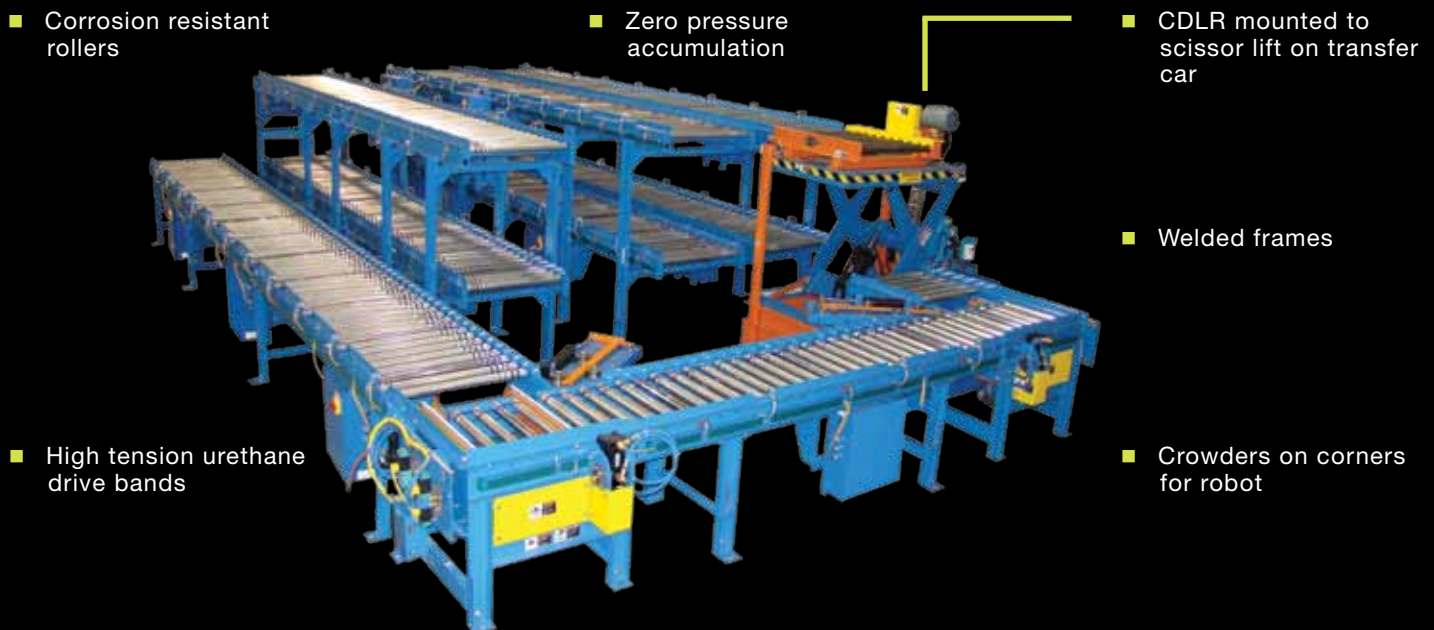

MDR CURVE

NO: 305

THE APPLICATION: Rubber Bail Handling

THE PRODUCT: 24 Volt Motor Driven Roller Tapered Curve

THE INDUSTRY: Tire Manufacturing

THE NEED: A tire manufacturer handling rubber bails needed to replace an existing curve within their curing process with a more energy efficient, low maintenance and low decibel conveyor that could withstand an environment with sea salt in the air.

THE SOLUTION: Omni Metalcraft Corp. provided an efficient and quiet 24 Volt Motor Driven Roller Tapered Curve. A special sub frame was also retro fitted to work with the facility's existing equipment. A custom corrosive resistant paint was utilized on the frame as well as stainless steel drive guards to withstand exposure to a high level of salt in the air. The motorized rollers were true tapered to maintain product orientation for wrapping.

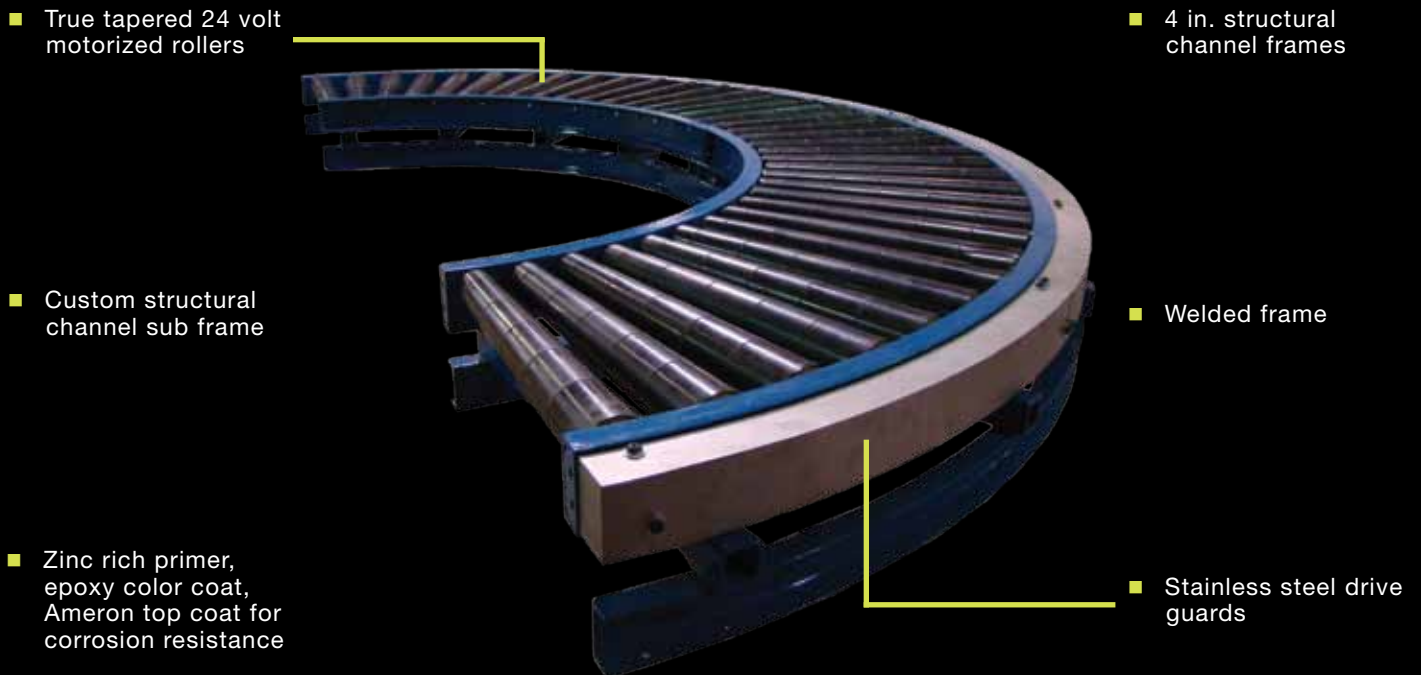

PACKOUT LINE AUTOMATION NO: 306

THE APPLICATION: Automating Tile Flooring Packout Lines

THE PRODUCT: 24V Flat Motor Driven Roller Conveyor and Urethane Belt Transfer

THE INDUSTRY: Construction Materials

THE NEED: A flooring manufacturer needed to create an automated accumulation and merge system to replace a very labor intensive stacking, loading and unloading process.

THE SOLUTION: Omni Metalcraft Corp. provided two sets of dual lane zero pressure accumulation Flat Motor Driven Roller Conveyor feeding a common merge line. There were two different tile sizes that each ran down a dedicated line each feeding a set of two lanes. Four lanes of unpackaged stacks were loaded randomly due to an inspection process preceding the packaging and palletizing operation. The zero pressure accumulation would allow stacks to feed and release automatically onto the merge lane when the zones were empty. All four lanes would merge into one lane for a boxing operation.

■ Zero pressure accumulation

■ Flat motor driven roller conveyor

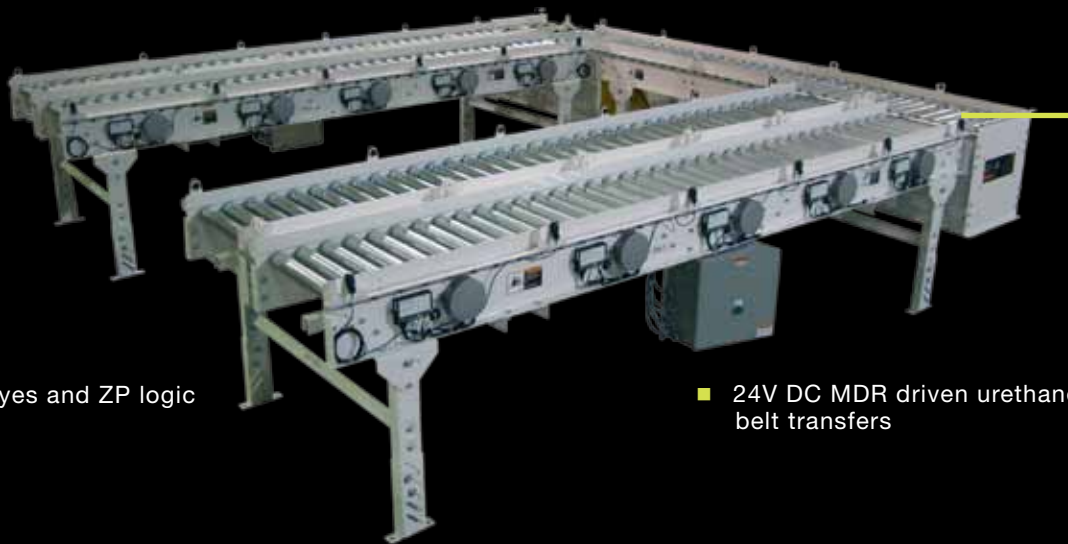

■ Photo eyes and ZP logic

■ 24V DC MDR driven urethane belt transfers

AUTOMOTIVE ASSEMBLY PREP LINE NO: 307

THE APPLICATION: Fully Automating a Parts Prep Assembly Line

THE PRODUCT: 24V Flat Motor Driven Roller Conveyor, Urethane Belt Transfer and Ball Transfer

THE INDUSTRY: Automotive

THE NEED: An automotive parts manufacturer wanted to create a low cost, energy efficient, fully automated zero pressure accumulation system to replace an existing minimum pressure system. The current system was allowing parts to touch causing damage.

THE SOLUTION: Omni Metalcraft Corp. provided two sets of dual lane zero pressure accumulation Flat Motor Driven Roller Conveyor. Products were loaded onto the system where they would accumulate prior to being manually transitioned to a ball transfer workstation. The entire system was fully automated requiring no start/stop controls. Overhead cross member supports were provided per customer request to support a cover to keep out contaminants. Full skirting and dust pans were also provided to keep the area clean and clear of dust.

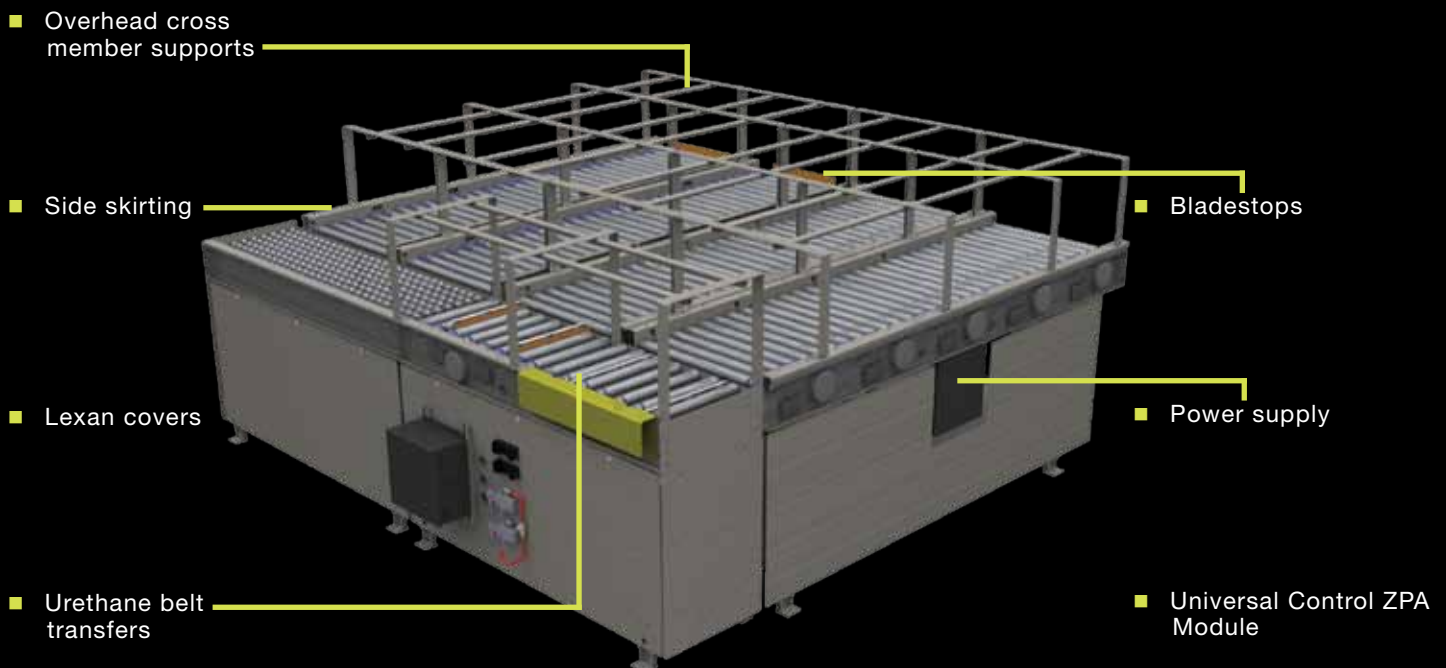

CHAIN DRIVEN FMDR PARTS STAGING NO: 308

THE APPLICATION: Robotic Cell Loading and Unloading in a Harsh Automotive Manufacturing Environment

THE PRODUCT: 24V Chain Driven Flat Motor Driven Roller Conveyor and Pop Up Chain Transfer

THE INDUSTRY: Automotive

THE NEED: An automotive manufacturer needed to install a new, fully-automated robotic cell staging line in a machining environment.

THE SOLUTION: Omni Metalcraft Corp. provided 24V DC Zoned Chain Driven Flat Motor Driven Roller Conveyor to withstand machining dust and fluid while also providing the controls and efficiencies of 24V DC flat motor driven conveyor. The system was zoned to provide fully automated part staging between several robots.



- Chain driven live roller conveyor

- Lexan covers

- 24V flat motor driven

- Urethane sleeves

- Zero pressure accumulation

- Pop up chain transfer with non-marking poly steel chain

BLOCK HANDLING CONVEYOR NO: 401

THE APPLICATION: Curve Conveyor for handling concrete blocks

THE PRODUCT: Blockveyor Power Belt Curve

THE INDUSTRY: Concrete Block and Cement

THE NEED: Concrete block manufacturers need to be able to continue their conveyor lines around corners, toward palletizers

THE SOLUTION: Omni Metalcraft Corp. can provide a Blockveyor belt curve that will stand up to this demanding environment, keeping products oriented where they need to be, when they need to be.

- Abrasion resistant urethane belt for demanding applications
- Leg cross bracing for added stability
- Angled catch pans to retain debris for easy removal
- Product orientation kept where you need it



- Shaft mounted drive kept above debris
- Easy access maintenance covers for ease of clean up
- Various shape and size product capability
- Powered or gravity transition rollers available

DAIRY PROCESSING SANITARY CONVEYOR NO: 402

THE APPLICATION: Transporting bulk cheese to a packaging operation

THE PRODUCT: Ultimate Class Stainless Steel Sanitary Belt Conveyor

THE INDUSTRY: Food Manufacturing

THE NEED: A dairy processor needed a sanitary design conveyor for ultimate cleanability and sanitation access. The conveyor also needed to withstand an aggressive washdown environment often seen in dairy processing.

THE SOLUTION: Omni Metalcraft Corp. provided an Ultimate Class Stainless Steel Sanitary Belt Conveyor designed to meet the customer's sanitary design criteria. The U-Class belt conveyor incorporated industry accepted sanitary designs as well as a custom designed belt take-up unit and motorized drive pulley to withstand the rigors of the dairy processing environment.

- 304 stainless steel framework

- Continuous ground and polished welds

- Tool-free removable and adjustable side guides

- Clean out ports for maximum sanitation and inspection access



- USDA accepted food grade belt

- Solid UHMW belt carry way

- Motorized stainless steel drive pulley

- Custom belt take-up

BAG TURNER NO: 403

THE APPLICATION: Turning Bags and Changing Orientation

THE PRODUCT: Belt Conveyor with Bag Turning Device

THE INDUSTRY: Food Manufacturing

THE NEED: A food manufacturer needed to change position and orientation of bags ranging from 25 to 50 lb. The bags start in the standing position for filling and sealing. They were transferred by a pneumatic pusher punching the paper bag, occasionally tearing the bag. This portion of the conveyor line also blocked an aisle resulting in the bag turning device needing to be portable as well.

THE SOLUTION: Omni Metalcraft Corp. designed a portable belt conveyor that utilizes the movement of the belt to convey it into a knock-down bar that gently pushes the bag down onto a slide pan. The slide pan works with the turning wheel to pull the bag down flat and turn the bottom of the bag as the leading edge for transfer.

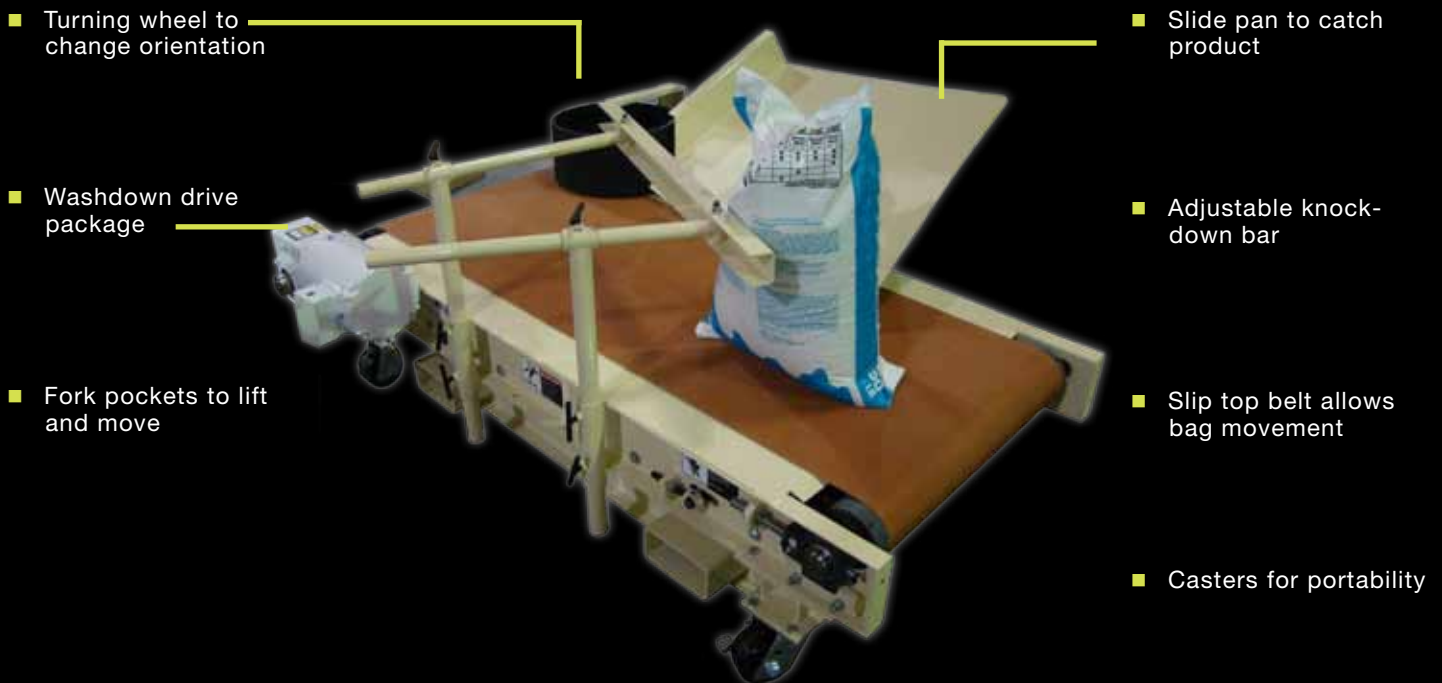

WOOD FINISHING BELT CURVE NO: 404

THE APPLICATION: Handles products of diverse sizes and maintains their orientation

THE PRODUCT: Power Turn Belt Curve

THE INDUSTRY: Furniture Manufacturing

THE NEED: A manufacturer needed to convey a diverse range of product sizes through a curve. The products of various size needed to turn without losing their original orientation, remaining centered and square.

THE SOLUTION: Omni Metalcraft Corp. provided a Power Turn Belt Curve that would not only be able to stand up to the demanding environment but convey a wide range of products from large flat boards to individual cabinets. The durable, easy to maintain design provides a simple design solution.

- Non-marring rough top belt

- Chain-free guiding system

- Easy to maintain design

- Maintains product orientation throughout the turn



- Powered or gravity transition rollers available

- Various shape and size product capability

- Variable speed reducers to refine throughput

- Jack bolt adjustable legs for fine tuning

CEMENT BAG TAKE-AWAY NO: 405

THE APPLICATION: Merging and Changing Orientation of Cement Bags Feeding a Palletizing Operation

THE PRODUCT: Metal Belt Conveyor, Incline and Straight Roller Bed Belt Conveyor and Gravity Roller Conveyor

THE INDUSTRY: Concrete Block and Cement

THE NEED: A concrete manufacturer needed a discharge system that would merge into one lane from two new bag fillers. The equipment needed to withstand harsh environmental conditions and still perform optimally.

THE SOLUTION: Omni Metalcraft Corp. provided two lanes of heavy duty take-away Metal Belt Conveyor with knock-down bars for bag flattening. Each lane fed an Incline Belt Conveyor allowing for a smoother transition, where a horizontal transition would have turned or damaged the bags. An impact reduction bar was utilized to break the bag's fall onto a line of accumulation belt conveyor eliminating bag tearing. The merged line of bags was then conveyed up a steeper belt incline to a Gravity Roller Conveyor where bags were manually unloaded onto a pallet.

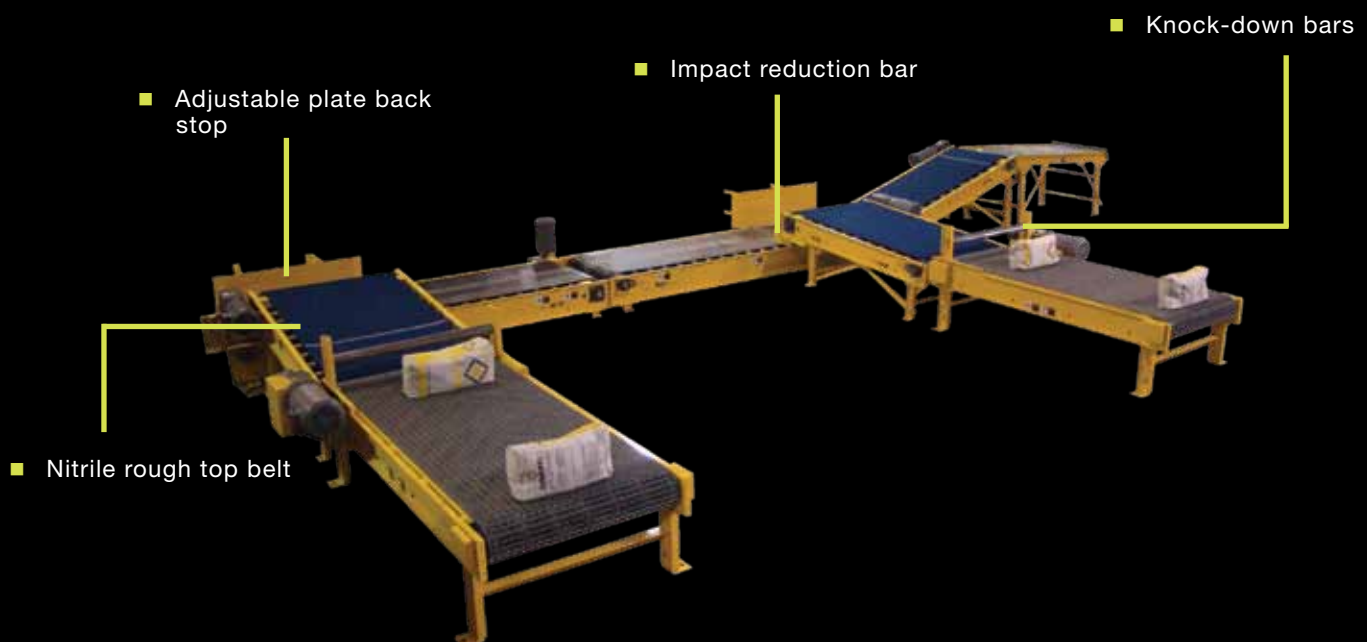

DUAL BELT EXHAUST CONVEYOR

NO: 406

THE APPLICATION: Conveying a Variety of Vehicle Exhausts

THE PRODUCT: Dual Belt Conveyor

THE INDUSTRY: Automotive

THE NEED: An automotive manufacturer needed to replace an existing manual operation. The conveyor system needed to accommodate the exhaust's awkward shape and multiple sizes.

THE SOLUTION: Omni Metalcraft Corp. provided a Dual Lane Belt Conveyor that allowed for operator load and unload access. An air motor was supplied per the customer's specifications.

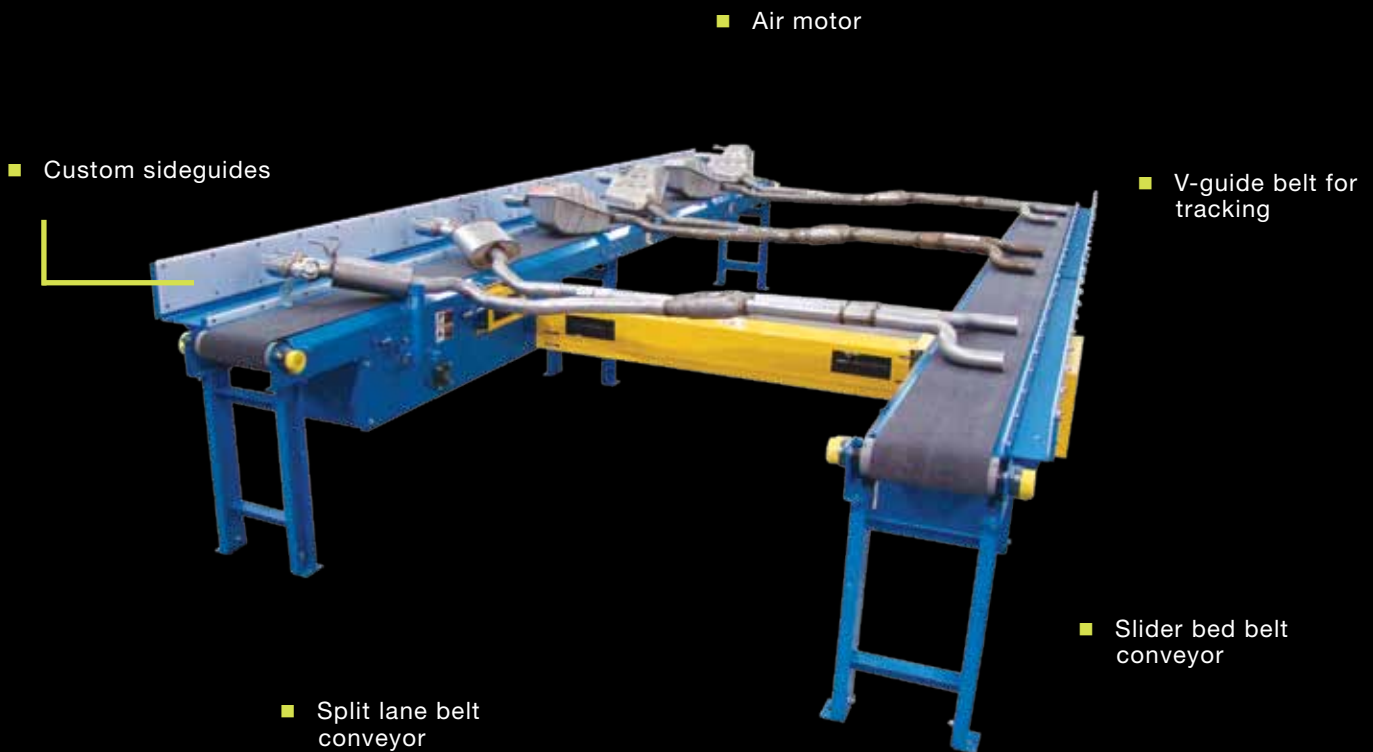

DUAL DIRECTION DISCHARGE CONVEYOR NO: 407



THE APPLICATION: Diverting a Roll in Either Direction off the Mainline

THE PRODUCT: Tilting Troughed Slider Bed Belt Conveyor

THE INDUSTRY: Household Consumer Products

THE NEED: A plastic wrap manufacturer needed to transport rolls of their product 60 feet with the capability of discharging in either direction onto a worktable.

THE SOLUTION: Omni Metalcraft Corp. provided a 55 foot long Troughed Belt Conveyor with a 5 foot Troughed Dual Discharge Conveyor. When the rolls reached the end of the line they could be discharged onto a work table on either side for final packaging.



TIGHT TRANSITION TILE CONVEYOR NO: 408

THE APPLICATION: Tight Transition

THE PRODUCT: Multi-Strand Roller Bed Belt Conveyor with Direct Drive

THE INDUSTRY: Construction Materials

THE NEED: A tile manufacturer needed to convey floor tile from one process to another. The conveyor needed to fit between existing pieces of process equipment and keep product transitions tight.

THE SOLUTION: Omni Metalcraft Corp. provided a Direct Driven Multi-Strand Urethane Belt Conveyor that would fit within the small footprint required. The 2.5" diameter drive pulley allowed for a much tighter transition than a standard belt conveyor allowing the product to successfully transition within the existing equipment parameters.

■ 2.5" diameter drive pulley

■ Urethane flat belts

■ Precision bearings

■ Self tracking sleeves



ROW FORMING SYSTEM UTILIZING ARB NO: 501

THE APPLICATION: Build Rows for Robotic Palletizing

THE PRODUCT: Activated Roller Belt Conveyor Row Forming System

THE INDUSTRY: Food, Beverage, Consumer Goods, Cosmetics, and other industries utilizing robotic carton palletizing.

THE NEED: Three different case sizes with the smallest having a throughput of 50 case per minute. The customer, Midwest Engineered Systems Group, needed to build layers with any case size without elaborate change-overs and loss of production.

THE SOLUTION: Omni Metalcraft Corp. utilized ARB technology which can not only build multiple rows, but also simple layers for robotic palletizing.



ARB Switch

- Short footprint
- Multiple case sizes
- Low maintenance

ARB Row Former

- Crowding with no pushers or rails
- Handles multiple case sizes without equipment change-over
- Able to form multiple rows combined with the upstream switch

HEAVY DUTY PLASTIC BELT CONVEYOR NO: 502

THE APPLICATION: Take away conveyor for cement board

THE PRODUCT: Heavy Duty Plastic Belt Conveyor

THE INDUSTRY: Building Material Manufacturing

THE NEED: A Manufacturer required a heavy duty, structurally sound, cleanable conveyor to withstand the cement board manufacturing environment. This conveyor was needed to transport cement board after being processed.

THE SOLUTION: Omni Metalcraft Corp. provided a Heavy Duty D-Class Plastic Belt Conveyor with structural side frames and washdown duty equipment. The conveyor was designed to withstand frequent spray down as well as incidental fork lift contact.

■ Customer requested washdown 2 HP Drive

■ Welded frame

■ Overhead drive

■ Open style belt design

■ D-Class epoxy paint

■ 8 in. structural channel frames



ARB RETRACTABLE BUMP TURN NO: 503

THE APPLICATION: Aligning, gapping, and selectively turning products for layer forming

THE PRODUCT: Activated Roller Belt™ Aligner with Retractable Bump Turn and Friction Top Gapping Conveyor

THE INDUSTRY: Food Manufacturing

THE NEED: A food manufacturer needed to align, gap, and change product orientation of two box sizes at high speeds and fit within the existing plant layout. The conveyor had to fit in a small window of space at the top of a three tier conveyor system.

THE SOLUTION: Omni Metalcraft Corp. designed an Activated Roller Belt™ (ARB) Aligner Conveyor integrated with a product gapper and case turner. The package would first be aligned to one side for scanning. A Plastic Belt gapper was then integrated to space out the packages to read its orientation with photoeyes. If the package orientation needed to change, a Retractable Bump Turn would activate allowing the product to rotate 90 degrees. All three application solutions were completed in 14 feet at 100 FPM.

■ 8 1/2" height profile

■ Intralox 900 Friction Top Belting for gapping

■ 30 degree ARB belting



■ Welded frame

■ UHMW sideguides for non-marring

■ Pneumatic retractable bump turn

ARB ALIGNING CONVEYOR NO: 504

THE APPLICATION: Diverting and justifying packages in a small footprint

THE PRODUCT: Activated Roller Belt™ Aligner and 90° Passive Divert

THE INDUSTRY: Food Manufacturing

THE NEED: A food manufacturer needed to properly orient and align packages of peanuts prior to a scanner and divert 90 degrees in only 8 feet at a speed of 150 FPM.

THE SOLUTION: Omni Metalcraft Corp. designed a solution no one else could in the limited space available. An Activated Roller Belt™ (ARB) Aligner Conveyor utilizing 45 degree ARB belting was designed to receive the packages, justify the packages to the right-hand edge of the conveyor for scanning, then diverts them 90 degrees.



FROZEN VEGETABLE SANITARY INCLINE NO: 505

THE APPLICATION: Convey Frozen Vegetables through an Elevation Change

THE PRODUCT: U-Class Incline Plastic Belt Conveyor with Cleats

THE INDUSTRY: Food Processing

THE NEED: A frozen vegetable processor needed to upgrade an existing sanitary conveyance operation within an existing footprint. A sanitary washdown conveyor was needed to convey frozen peas, corn and carrots up a 40° incline to dump into a 52" tall tote.

THE SOLUTION: Omni Metalcraft Corp. designed a Stainless Steel Sanitary Incline Plastic Belt Conveyor to meet the customer's sanitary design criteria and fit within the existing footprint. The plastic belt was equipped with cleats to convey the loose frozen vegetables up the steep incline. The conveyor also maintained industry accepted sanitary designs for direct food contact and frequent washdown.

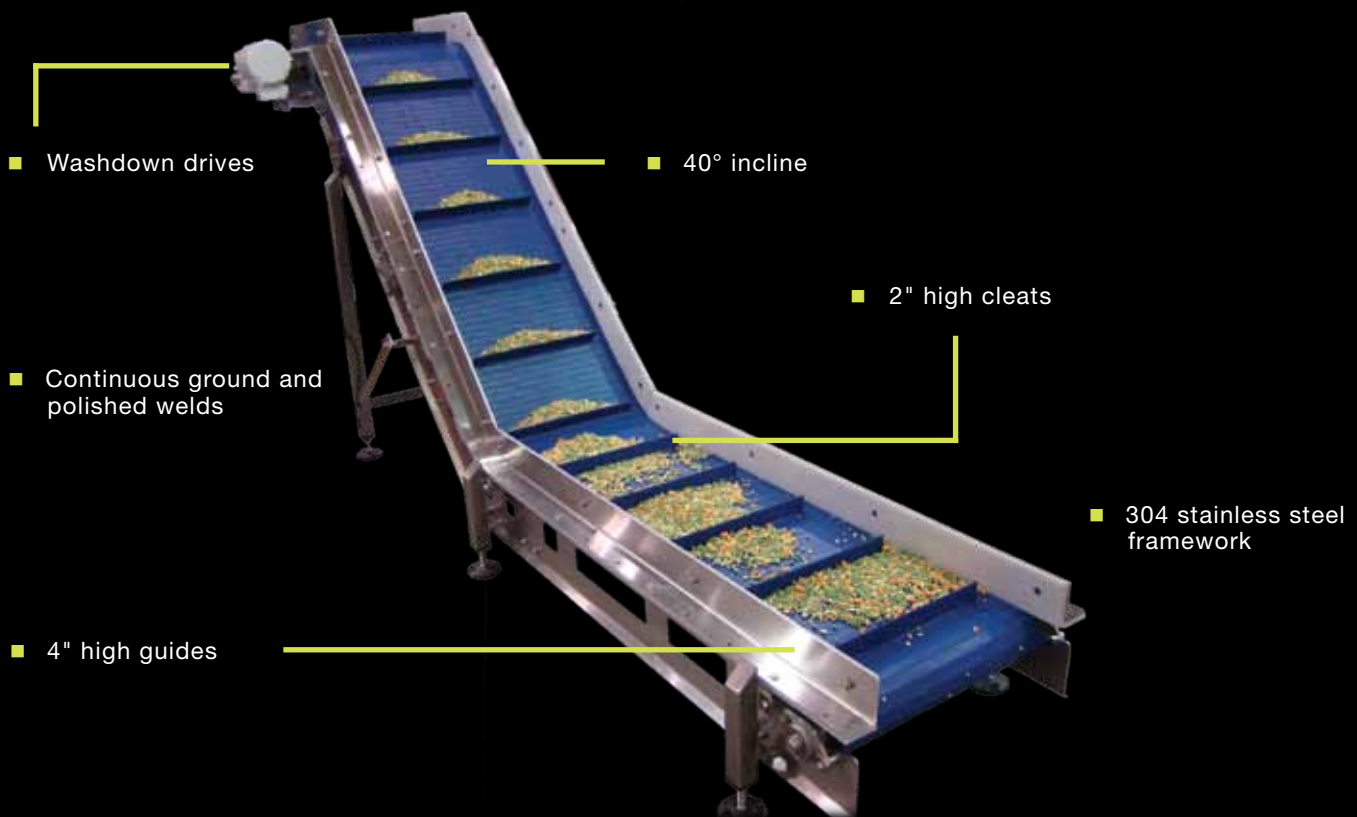

INKJET PRINTING AND CASE TURNING NO: 506



THE APPLICATION: High Resolution Inkjet Printing and Case Turning

THE PRODUCT: Plastic Belt Conveyor

THE INDUSTRY: Consumable Goods

THE NEED: A solvent manufacturer needed to turn a case and print a high resolution barcode cost effectively.

THE SOLUTION: Omni Metalcraft Corp. responded to the customer's design needs and provided a Modular Plastic Belt Conveyor outfitted with a flat top belt. The conveyor was also equipped with an adjustable bump turn. The case of solvent conveyed smoothly through the printing process providing a positive barcode that could be read, while the low friction modular plastic belting allowed for clean case turning.

■ Case aligning prior to printing

■ High resolution barcode



■ Adjustable bump turn

■ Low friction modular plastic belting

■ Smooth, even conveyance through the printing process

TIRE UNLOADING SYSTEM

NO: 507

THE APPLICATION: Ergonomic Tire Unloading

THE PRODUCT: Chain Driven Live Roller Conveyor with Ultrex Sleeves, Pneumatic Lift Gate, Flowrail Guides and Transverse Roller Top (TRT) Conveyor

THE INDUSTRY: Automotive

THE NEED: An automotive manufacturer added two new docks to their current tire system. They needed to receive tires from the new docks to existing plant conveyor.

THE SOLUTION: Omni Metalcraft Corp. provided a Chain Driven Live Roller Conveyor Pneumatic Lift Gate to bridge the gap between the delivery truck and the plant conveyor while also allowing operators to pass through. Transverse Roller Top Plastic Belt Conveyor was integrated with the CDLR to transfer the tires from the lift gate to the existing conveyor.

■ Ultrex sleeves for accumulation

■ Intralox Series 400 TRT Belt

■ Flowrail guides

■ Radius roller guides



■ Pneumatic lift gate

VERTICAL SORTING TABLE TOP CONVEYOR NO: 508

THE APPLICATION: Diverting Packaged Food in a Packaging Process

THE PRODUCT: Stainless Steel Washdown Modular Table Top Conveyor with Pneumatic Pivoting Device

THE INDUSTRY: Food Processing

THE NEED: A cheese manufacturer wanted to vertically feed two different packaging operations with one conveyor. Washdown specifications were desired due to the sanitary specifications in this part of the packaging process.

THE SOLUTION: Omni Metalcraft Corp. provided a Stainless Steel Washdown Duty Modular Table Top Conveyor that was capable of pivoting vertically using pneumatics. The conveyor pivots to service two levels, diverting products to two separate areas of the facility providing the flexibility desired easily and efficiently.

■ Pneumatic pivot device

■ 882 LF Tab Side Flexing Chain



■ Washdown drive

■ Adjustable side guides

■ Stainless washdown construction

SMALL FOOTPRINT ELEVATION CHANGE NO: 509

THE APPLICATION: Changing Elevation in a Small Footprint Cost Effectively

THE PRODUCT: Incline Plastic Belt Conveyor

THE INDUSTRY: Food Manufacturing

THE NEED: A cheese manufacturer was adding a new packaging line to their facility. This new line needed to feed their overhead system within a limited footprint.

THE SOLUTION: Omni Metalcraft Corp. provided a 60 Degree Incline Plastic Belt Conveyor with roller cleats. The steep incline allowed the cased cheese to be transported up to the overhead conveyor system within a limited footprint. The rollers attached to the belt acting as cleats not only served to elevate the product but also eliminated the need to synchronize horizontal infeed and inclining discharge conveyors. Overhead guide rails were utilized to keep the boxes from tipping backwards while inclining.



TIRE AND WHEEL ASSEMBLY INCLINE

NO: 510

THE APPLICATION: Tire and Wheel Assembly

THE PRODUCT: Heavy Duty, Incline Plastic Belt and Transverse Roller Top (TRT) Conveyor with Manual Divert Arms

THE INDUSTRY: Automotive

THE NEED: An automotive manufacturer needed to rework an existing facility to create more storage and flexibility. They needed a new piece of equipment to feed tire and wheel storage silos.

THE SOLUTION: Omni Metalcraft Corp. provided a Heavy Duty, Incline Plastic Belt Conveyor divided into two lanes by a full length lane divider with flowrail guides. Non-skid belting and hold downs were utilized to guide the tires up the incline. The tires fed onto TRT Plastic Belt Conveyor equipped with manually operated flow diverters discharging onto tire storage silos mounted to each side or allowing tires to pass through if required.

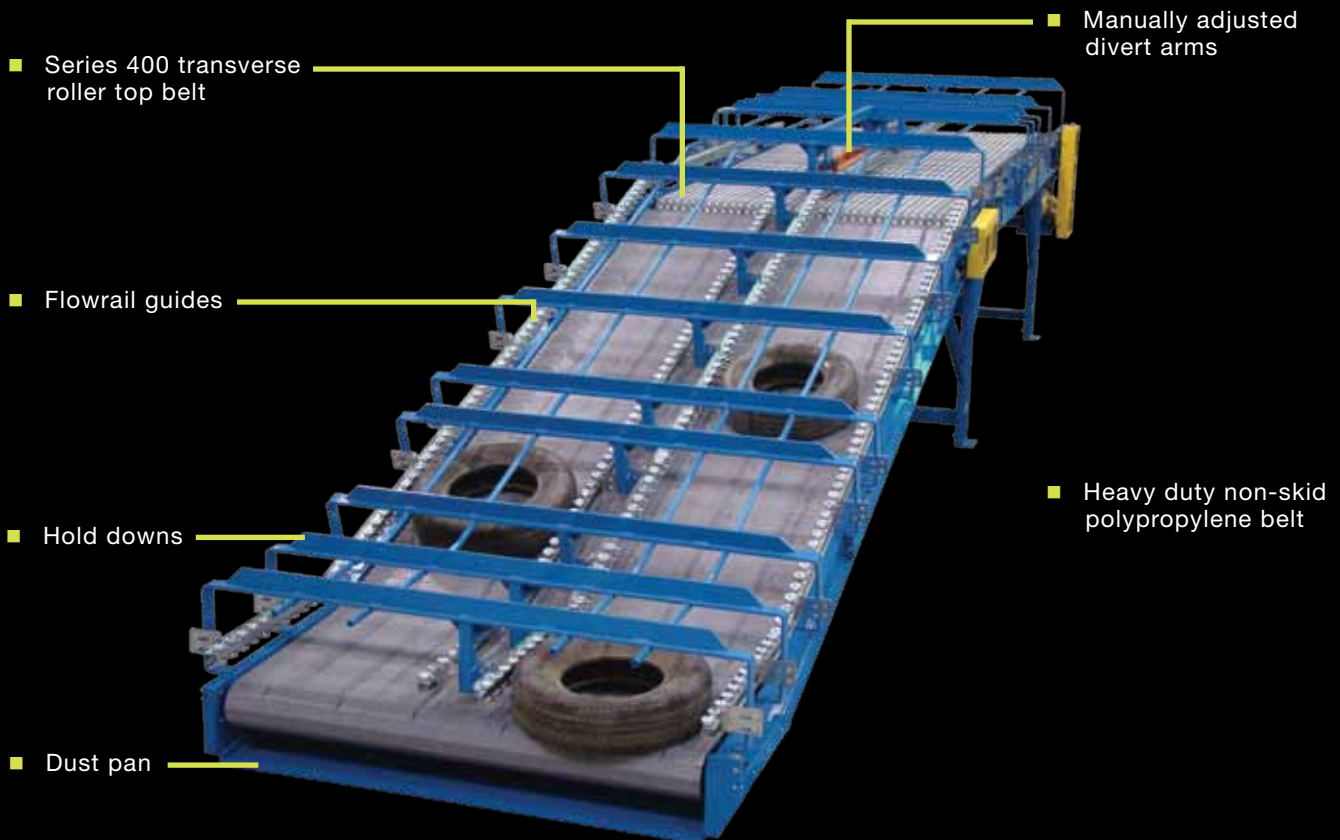

CENTERING HERRINGBONE BDLR NO: 601

THE APPLICATION: Merging furniture with centering conveyor

THE PRODUCT: Heavy Duty Herringbone Belt Driven Live Roller Conveyor

THE INDUSTRY: Furniture Manufacturing

THE NEED: A furniture manufacturer needed to replace an existing centering conveyor. This conveyor receives two lanes of furniture ranging in size, shape and weight up to 350 lbs. The furniture had irregular bottoms and uneven weight distribution.

THE SOLUTION: Omni Metalcraft Corp. designed a massive Heavy Duty Herringbone Belt Driven Live Roller Conveyor with tight roller centers to merge and center the furniture. The tight roller centers not only supported the irregular product surfaces but also reduced the chance of wrapping material becoming caught around the rollers.

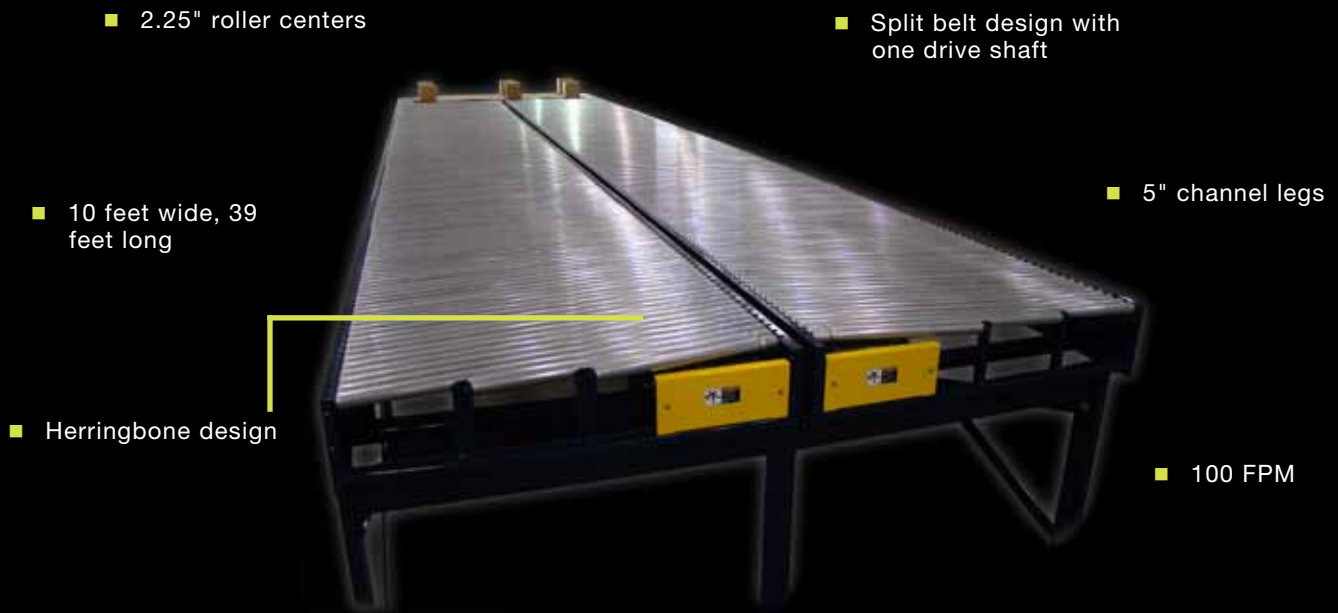

VACUUM CUP GRAVITY CONVEYOR NO: 701

THE APPLICATION: Portable lightweight panel drill press workstation

THE PRODUCT: PVC Roller Gravity Conveyor with Vacuum Cups

THE INDUSTRY: Panel Fabrication

THE NEED: A Panel Manufacturer needed a portable workstation to move different size layers of lightweight paneling as well as hold the paneling in place without marking or damaging it.

THE SOLUTION: Omni Metalcraft Corp. worked with the customer's design to provide a portable PVC Roller Gravity Conveyor equipped with Vacuum Cups. The lightweight gravity conveyor was designed with casters so the conveyor could be easily moved to and from the drill press workstation. Adjustable vacuum cups were integrated into the bed of the conveyor at set increments for "suctioning" different size panels in place to be drilled.

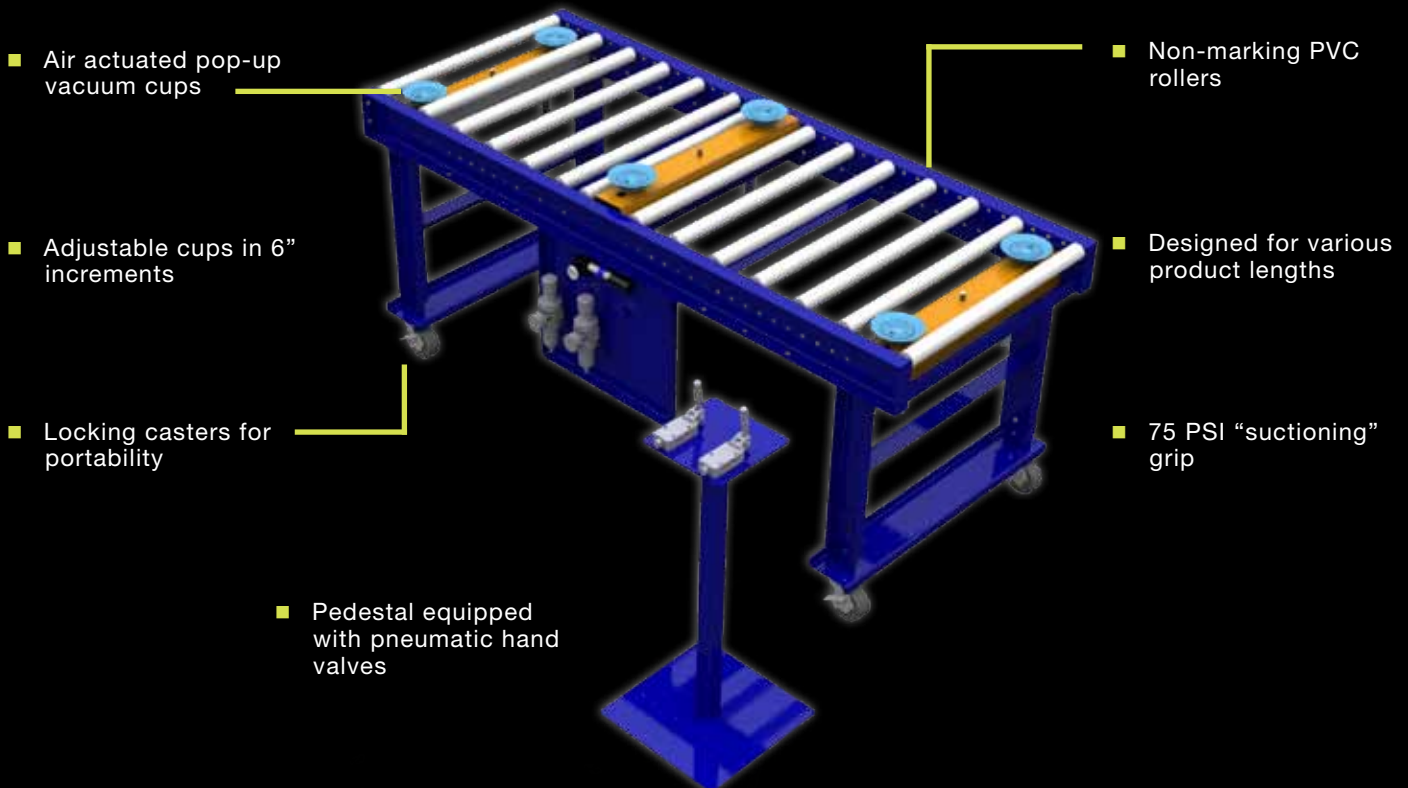

TIRE STORAGE AND ASSEMBLY

NO: 702

THE APPLICATION: Tire Storage and Assembly

THE PRODUCT: Gravity Roller Silo with Flowrail Guides, Pneumatic Tire Tip Up and Ball Transfer Workstation

THE INDUSTRY: Automotive

THE NEED: An automotive manufacturer needed to replace an existing tire silo to increase production, buffer storage capacity, and accommodate new tire sizes. The silo needed to bring tires from an existing second level system down to floor level for assembly.

THE SOLUTION: Omni Metalcraft Corp. provided a Gravity Roller Silo with Flowrail Guides to store and transport tires to a lower level. Tires were fed into the silo where they were stored until an existing escapement released them to the Ball Transfer Workstation. A pneumatically actuated tipper presented the tires ergonomically to the operator for assembly.

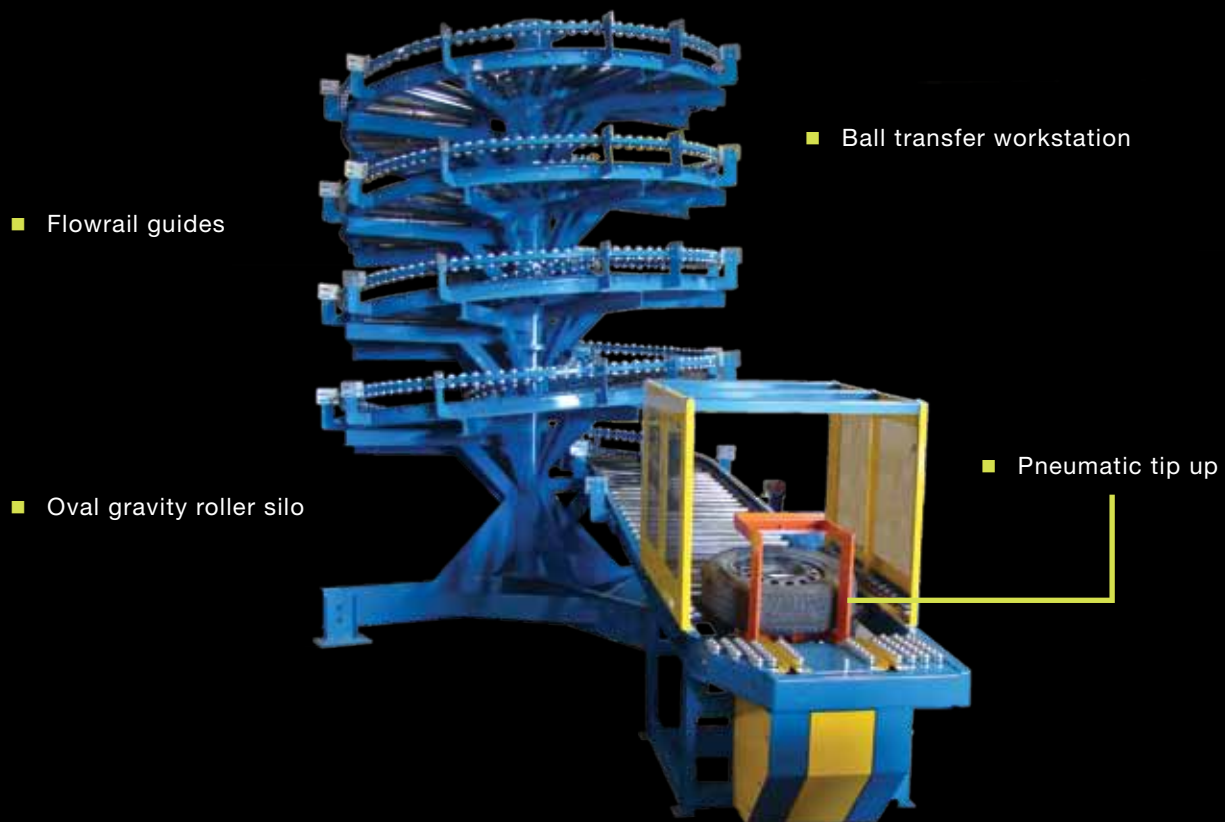

BALL TRANSFER FILLING WORKSTATION NO: 703

THE APPLICATION: Box Filling Workstation

THE PRODUCT: Ball Transfer with a Pneumatic Actuated Pan

THE INDUSTRY: Durable Goods

THE NEED: A home security component manufacturer needed to replace an existing packaging system. New workstations were needed for more ergonomic and simplified box filling.

THE SOLUTION: Omni Metalcraft Corp. provided a Ball Transfer Table with a Pneumatic Actuated Pan for filling boxes. The pan actuates, removing the box from the ball transfer, holding the box in place for filling then disengaging to allow workers to easily transfer the boxes onto the main line.



- Pneumatic actuated pan
- Hand valve operated
- 150 lb capacity ball transfer units

SPLIT LANE GRAVITY CONVEYOR PALLET SINGULATOR NO: 704

THE APPLICATION: Unloading Pallets onto AGV Carts

THE PRODUCT: Split Lane Gravity Roller Conveyor with Pneumatic End Stop and Rotating Blade Stop

THE INDUSTRY: Automotive

THE NEED: An automotive manufacturer needed to replace an existing pallet loading/unloading line.

THE SOLUTION: Omni Metalcraft Corp. provided Gravity Roller Conveyor load/unload lanes. Fork trucks loaded automotive cockpit pallets onto the gravity conveyor set at a slight decline. The rotating stop was used to singulate pallets by holding them one pallet position back. The split blade stop at the discharge end was utilized as an escapement to release the pallets onto an AGV cart.



SCISSOR LIFT WHEEL ASSEMBLY STATION NO: 801

THE APPLICATION: Vertical lift of tractor frames for a four wheel assembly application

THE PRODUCT: Four custom scissor lifts actuating simultaneously

THE INDUSTRY: Heavy Duty Agricultural Equipment Manufacturer

THE NEED: A tractor manufacturer needed narrow lifting devices to lift the heavy frame off a transportation cart for attachment of all four wheels during a one step operation. The solution also had to accommodate multiple frame length and widths.

THE SOLUTION: Omni Metalcraft Corp. provided four custom scissor lifts for the tractor manufacturer that actuated simultaneously to raise the tractor frame for wheel assembly. Pop up wheels were integrated under each scissor lift, allowing easy adjustment for the multiple tractor sizes. All four scissor lifts were powered off one power unit which utilized a single flow divider for level lifting of the tractor frame in all four corners.

- One flow divider for level lifting of all four scissor lifts

- 8000 lbs. lifting capacity per scissor lift



- Narrow lifts on subbase with easy access maintenance panels

- Retractable wheels placed on compression springs for mobility

ROLL HANDLING UPENDER NO: 802

THE APPLICATION: Repositioning large rolls onto a slip sheet for packaging

THE PRODUCT: Upender with Trough Gravity Roller Infeed Conveyor and Chain Driven Live Roller Discharge Conveyor

THE INDUSTRY: Textile Manufacturing

THE NEED: A diaper manufacturer needed to perform a new operation in their plant. An operator would manually slide a roll of fabric onto the infeed trough and place a slip sheet on top of it. The upender would reposition the roll so the slip sheet would end up on the underside. The powered discharge conveyor would feed the roll onto a transfer car for further packaging.

THE SOLUTION: Omni Metalcraft Corp. worked with the customer to develop a custom Upender with infeed and discharge conveyor designed for this application. A gravity roller trough was designed to withstand potential point loading for rolls up to 2500 lbs. The rollers for the conveyor were designed with ABEC precision, shielded, sealed, and grease packed bearings to withstand the dirty, dusty fabric environment.

- 4000 lbs capacity

- Trough gravity roller conveyor

- Shielded, sealed, grease packed ABEC precision bearings

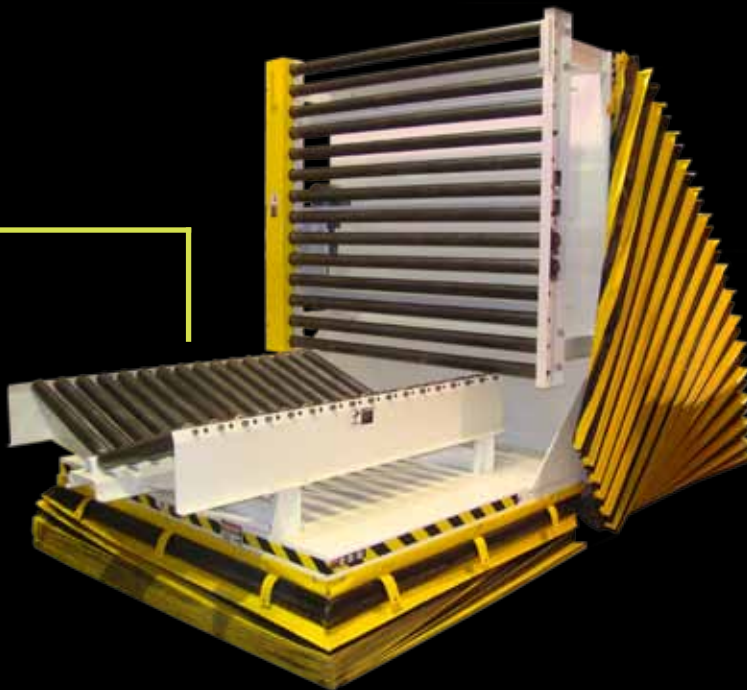

- Powered chain driven live roller conveyor

- Hydraulic actuated

- Accordion skirting

HEAVY DUTY HIGH CYCLE SCISSOR LIFT NO: 803

THE APPLICATION: Industrial Manufacturing Workstation

THE PRODUCT: Heavy Duty Pit Mounted Scissor Lift

THE INDUSTRY: Industrial Manufacturing

THE NEED: A manufacturer required a heavy duty, pit mounted scissor lift for an industrial application. Due to the fast pace application high cycles were needed. The size constraints of the pit required the lift to be constructed as a single scissor configuration and the need for high vertical travel mandated heavy duty construction for added stability.

THE SOLUTION: Omni Metalcraft Corp. designed a Heavy Duty Pit Mounted Scissor Lift with many custom features specific to high cycle usage and the customer's pit design parameters. The scissor lift was designed with leg stiffening bars for additional support for the high vertical travel allowing the lift to sustain the required weight and needed cycles.



CUSTOM PIPE HANDLING SCISSOR LIFT NO: 804

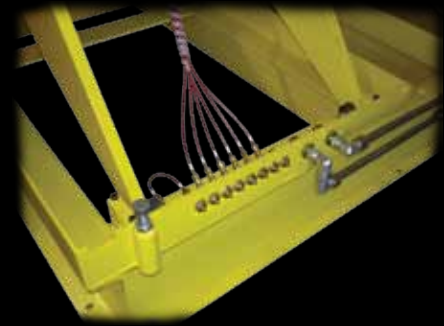

Central lube point

THE APPLICATION: Stacking and Moving Pipe

THE PRODUCT: Double Wide Scissor Lift

THE INDUSTRY: Metal Manufacturing

THE NEED: A metal pipe fabricator needed to replace an existing scissor lift for their pipe handling operation. A heavy duty, long lasting piece of equipment was needed to withstand the harsh foundry environment of stacking up to 30,000 lbs of pipe to be unloaded by crane.

THE SOLUTION: Omni Metalcraft Corp. designed a custom, very heavy duty, double wide hydraulic scissor lift that would withstand high cycles and foundry abuse. Due to the extremely abusive environment routine maintenance was needed in order to keep the lift running. We worked with the manufacturer to develop a remanufacturing schedule that allows them to rotate in remanufactured lifts extending the operating life.

■ Garmax bushings with regreasable pins

■ 1 inch thick steel plate arms

■ Central lube point

■ Precision bearing cam followers for smoother operation and longer life

■ Hand tool removable pins for easy maintenance

■ High cycle Parker NFPA cylinders

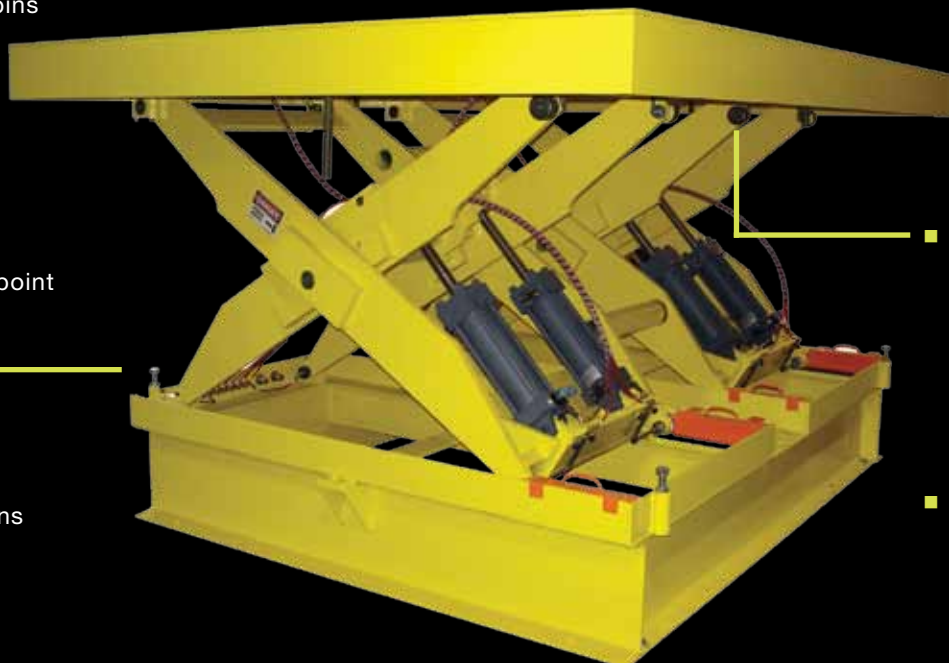

BIN TILTER

NO: 805

THE APPLICATION: Ergonomic Manual Parts Unloading

THE PRODUCT: Hydraulic Bin Tilter

THE INDUSTRY: Automotive

THE NEED: An automotive manufacturer needed to tilt large bins 90 degrees to provide ergonomic access to assembly parts. The tilter the customer currently had in place had been experiencing premature wear, and therefore, required a better unit.

THE SOLUTION: Omni Metalcraft Corp. provided a custom 4,500 lb. capacity Hydraulic Bin Tilter. Fork pockets were added to allow the unit to be moved easily throughout the facility. The power unit was mounted internally for a clean, compact solution.

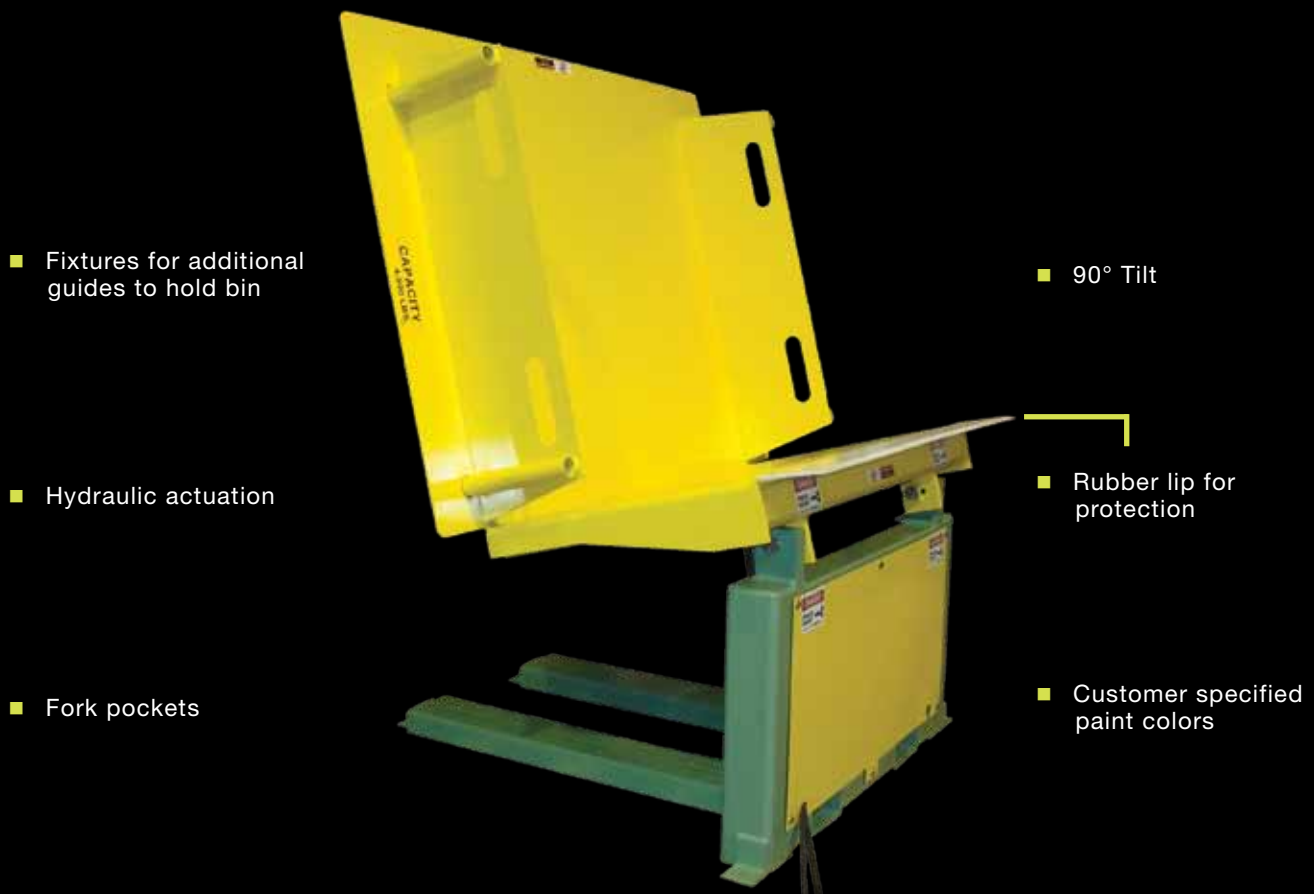

STEEL WATER TANK MANUFACTURING NO: 806



THE APPLICATION: Conveying and Upending 40 Foot Long, 8 Ton, Sheets of Steel

THE PRODUCT: Gravity Roller Conveyor, Chain Driven Live Roller Conveyor Embedded with Pop-Up Chain Transfers, Chain Conveyor and Hydraulic Upender

THE INDUSTRY: Metal Manufacturing

THE NEED: A water tank manufacturer constructing a new steel handling facility needed a new rolled steel handling line. Extremely large steel sheets needed to be conveyed from the roll press and upended 90 degrees for overhead crane pick up to feed a shot blasting operation. The equipment needed to be built at a low elevation to match additional equipment in the facility.

THE SOLUTION: Omni Metalcraft Corp. provided Gravity Roller Conveyor and Chain Driven Live Roller Conveyor with pop-up Chain Transfers to feed the steel sheets onto six strand wide Chain Conveyor. The heavy duty Chain Conveyor fed the Upender which tilted 90 degrees allowing the overhead crane to transport the sheet to the shot blasting machine.

- 5 hp two strand pop-up chain transfers
- Manually adjustable end stop
- 20 hp hydraulic upender
- 19" top of chain
- Six strand chain conveyor



TIRE MOUNTING LIFT STATION NO: 807



Tandem Scissor Lifts with Drive off Ramps

THE APPLICATION: Mounting Tires onto Heavy Duty Tractors

THE PRODUCT: 75,000 lb Capacity Hydraulic Tandem Scissor Lift and Two 30,000 lb Capacity Pneumatic Tandem Scissor Lifts with Drive off Ramps

THE INDUSTRY: Agricultural Equipment and Machinery Manufacturing

THE NEED: Within an existing facility, a tractor manufacturer needed to accommodate a new operation utilizing AGVs. They needed a sturdy, heavy duty method for lifting a tractor frame on an AGV without creating any side-to-side wavering as the tires were mounted.

THE SOLUTION: Omni Metalcraft Corp. provided a 23 foot long by 2 1/2 foot wide Hydraulic Tandem Lift with mechanical lifting pads on the far ends with locating pins and two smaller Pneumatic Tandem Ramp Lifts on each side. An AGV unit would drive the tractor frame onto the main tandem lift; the pads would lift the AGV up 3 inches due to the sensitivity of its wheels. The entire lift would then rise for tire installation. The tires were installed overhanging the main tandem lift. Once the tires were mounted, the lift would lower, resting the tires on the two ramp lifts allowing the AGV to drive out from under the tractor. The ramp lifts would lower to the ground allowing the tractor to drive off.



- Hydraulic actuated tandem lift
- Locating pins
- Mechanically raised pads

SMALL PRODUCT TRANSITION CONVEYOR NO: 901

THE APPLICATION: Transitioning small products from a discharge conveyor to a take away conveyor

THE PRODUCT: Small Product Transition Conveyor

THE INDUSTRY: Concrete Block Manufacturing

THE NEED: A concrete block manufacturer needed to transition a very small footprint block with a high aspect ratio base to height from one conveyor to the next without the block falling. The conveyor processed the blocks through a curing station resulting in the need to be washdown capable.

THE SOLUTION: Omni Metalcraft Corp. designed a rugged transition conveyor that could transport these small but heavy products. This was done by utilizing a small 5/8" diameter nose bar which was mounted as close as possible to the adjacent wire mesh conveyor. A small UHMW roller was set just above the surface of the belt, while a 3/4" half round aided in filling the gap at the opposite end making both transitions very smooth.

- Up to 250 lbs capacity

- Multiple filler plate options based on application

- Powered or slaved available

- Up to 30 FPM



- Woven stainless steel wire mesh belting

- Stationary 5/8" dia. nose bars

- 2 1/2" end-to-end transfer

- Slotted end cap for easy mounting

OmniMetalcraft Corp.

P.O. Box 352 ■ Alpena, Michigan 49707
Phone 989.358.7000
Fax 989.358.7020
info@omni.com
www.omni.com