

TIMKEN

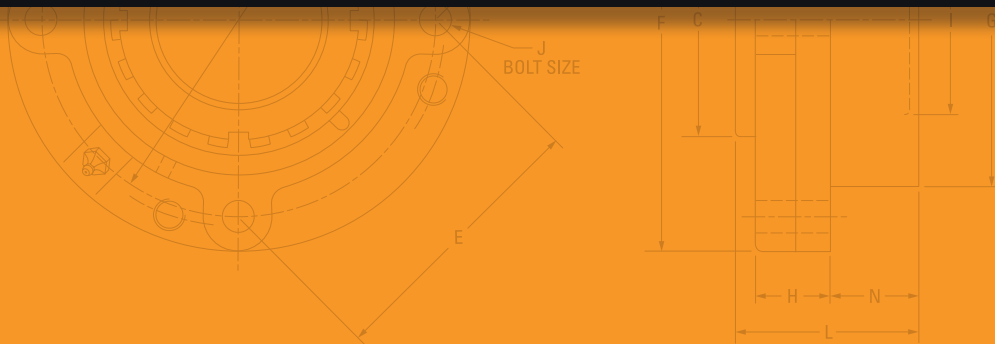

TIMKEN® SPHERICAL ROLLER BEARING SOLID-BLOCK HOUSED UNITS



TIMKEN® HOUSED UNIT CATALOG INDEX

OVERVIEW.....	2
INTRODUCTION.....	4
SHELF LIFE POLICY.....	11
Spherical Roller Bearing Solid-Block Housed Units.....	C-1

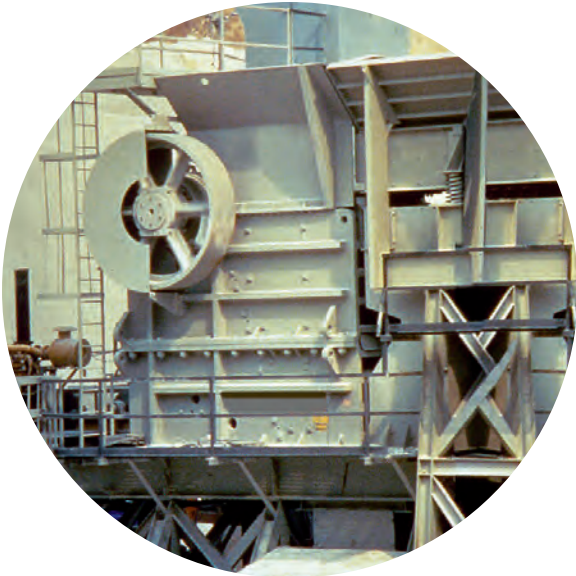

GROW STRONGER WITH TIMKEN

Every day, people around the world count on the strength of Timken. Our expertise in metallurgy, friction management and mechanical power transmission helps them accelerate improvements in productivity and uptime.

We supply products and services that can help keep your operations moving forward, whether you need drive train kits for commercial vehicles, durable housings for bearings in dirty environments, couplings that avoid metal-to-metal contact between motors and gearboxes, repair services for bearings and gearboxes, roller chain for dry, abrasive and high-moisture applications or other products or services for your applications.

When you choose Timken, you receive more than high-quality products and services: you gain a worldwide team of highly trained and experienced Timken people committed to working collaboratively with you to improve your business.

Globally, our 17,000 people provide reliable answers for a wide range of operations in manufacturing, mining, medical equipment, aerospace, transportation, oil and gas – and other diverse industries.

INCREASE YOUR EQUIPMENT UPTIME

In addition to high-quality bearings and mechanical power transmission components, we provide valuable integrated products and services. For example, we offer repair services and monitoring equipment that can alert you to problems before they impact your uptime.

Additionally, we offer a broad selection of seals, premium lubricants, lubricators, couplings and chain to keep your operations moving smoothly.

Our 12 technology centers in the United States, Europe and Asia help pioneer tomorrow's innovations with extensive basic and applied scientific research programs. Through internal development and strategic acquisition of innovative companies, we continue to expand our portfolio of highly engineered bearings, power transmission products and advanced services.



RUGGED TIMKEN® HOUSED UNITS HELP PROTECT YOUR BEARINGS

When you choose sturdy Timken housings, your bearings can keep rolling smoothly, even in harsh environments impacted by dirt, debris, water and other contaminants. Timken engineers designed special housings to withstand tough challenges on the job.

Protected inside durable cast iron or steel, our highly engineered Timken® ball and roller bearings work hard to help you manufacture and transport materials, without excessive maintenance due to contaminants.

Choose from our selection of housed units designed with ball, tapered and spherical bearings. Select enhancements like Timken® seals, lubricants and housing covers best suited for each task. Our engineers help you choose the right combination of bearings and accessories to extend bearing life, increase uptime and reduce maintenance costs.

Of course, you can interchange existing products with Timken housed units because our bolt holes and shaft centerline dimensions are designed to conform to industry standards.

Timken® housed units reflect our strengths in metallurgy, engineering and manufacturing. We produce all our bearings in adherence with the Timken Quality Management System for consistency in all our facilities around the world.



TIMKEN® BALL HOUSED UNITS OFFER EASY INSTALLATION, FLEXIBLE OPTIONS

Timken® ball housed units, available in a variety of sizes and types, feature wide-inner-ring ball bearings that provide additional shaft support and locking options. The Timken® wide-inner-ring ball bearing is designed for straight shafts and can be positioned without shoulders, locknuts or adapters.

For easy installation, our ball housed units can be ordered pre-assembled with bearings, housings, seals and locking systems. Choose from pillow blocks, flanged cartridges, take-up units and cylindrical cartridges. Our cast-iron, pressed-steel and other optional materials give you durable choices for the exterior covers. Timken® locking options include set screws, self-locking collars and concentric collars.

Timken® Shaft Guarding Technology™ deters set-screw damage to shafts by placing a hardened band in the groove along the inner ring of the bearing. The set screws press against the band to transfer gripping pressure onto the shaft, preventing nicks, as well as raised-metal or permanent shaft damage. The stainless-steel band resists corrosion on the shaft. This system is particularly helpful for applications where it would be expensive and time-consuming to replace shafts.

TYPICAL INDUSTRIES AND APPLICATIONS

Use Timken ball bearing housed units in agricultural applications, fans, blowers, food processing devices and conveyors.



TIMKEN® TYPE E HOUSED UNITS REPEL CONTAMINANTS, ENHANCE PERFORMANCE

Timken® Type E tapered roller bearing housed units feature double-lip seals and locking collars that protect against water and other contaminants. This double-lip seal design blocks debris and retains grease better than single-lip or triple-lip seals, according to Timken 2012 laboratory tests.

Its cast-iron exterior includes a corrosion-resistant electro-coat finish for the housing and collar, a more durable shield than industry-standard powder coating or black oxide. Set screws with nylon patches reduce back-out, even in rigorous applications.

Premium Timken® tapered roller bearings inside Type E housings are manufactured with advanced technology that results in longer predicted useful bearing life than other housed units with standard bearings. Designed with optimized bearing profiles and improved surface finishes, Timken tapered roller bearings operate efficiently within the housing.

TYPICAL INDUSTRIES AND APPLICATIONS

Use Timken Type E housings for pulp and paper, power generation, mining, cement and aggregate industries. Our Type E housed units also are widely used in equipment for air-handling and treatment of water and waste water. Other common machine applications include mixers, washers, shredders, mills and oven/furnace roller beds.



TIMKEN® SPHERICAL ROLLER BEARING SOLID-BLOCK HOUSED UNITS WITHSTAND HARSH CONDITIONS

Timken® spherical roller bearing solid-block housed units stand up to rugged conditions. Composed of solid steel, they withstand most falling debris and handle up to ± 1.5 degrees of misalignment. The steel used in these products is up to two times stronger than cast iron, which may break or pound out in tough applications.

Timken spherical roller bearing solid-block housed units come in five locking configurations: single and double set screws, eccentric locks for reversing applications, tapered-adaptor locks and double-tapered locks.

Choose from three sealing options: labyrinth seals (for high-speed, high-temperature applications) and triple-lip seals made of either nitrile or urethane. Timken® steel auxiliary covers provide an extra layer of protection, and they can be filled with Timken lubricants.

TYPICAL INDUSTRIES AND APPLICATIONS

Use Timken spherical roller bearing solid-block housed units in metals mills, aggregate and cement, mining, power generation, agriculture, pulp, paper, sawmills and other forest industries.



TIMKEN® SAF SPLIT-BLOCK HOUSED UNITS BEAR HEAVY LOADS

Timken® SAF split-block housed units are available in rugged cast iron, ductile iron or cast steel to match a range of industrial environments. Our Timken SAF housed units have separate, matched caps and bases. In larger sizes where housed units are heavier, this split-block design eases installation. Remove the cap using a pry-tool slot for bearing inspection, service and replacement.

Available in a variety of shaft sizes, Timken SAF units offer the choice of tapered-bore design for easy mounting or a straight-bore design for better axial location. The block can be converted from fixed to float by removing the stabilizing ring. Several sealing options protect against contamination, including a standard seal, which is a precision aluminum triple-ring labyrinth seal.

TYPICAL INDUSTRIES AND APPLICATIONS

Use Timken SAF housed bearings in power generation, coal, mining, aggregate, cement, metals, pulp, paper and other forestry operations, water treatment and food processing industries. Applications include warehousing, conveyors, movable bridges/heavy structures, industrial fans and blowers.



TIMKEN® SNT SPLIT PLUMMER BLOCKS CARRY HEAVY LOADS

Timken® SNT split plummer blocks are available in metric sizes. Their rugged cast iron, ductile iron or cast steel designs stand up to a range of industrial environments. Our Timken SNT plummer blocks have separate, matched caps and bases. In larger sizes where plummer blocks are heavier, this split-block design eases installation. Remove the cap using a pry-tool slot for bearing inspection, service and replacement.

Available in a variety of metric shaft sizes, Timken SNT plummer block units offer the choice of tapered-bore design for easy mounting or straight-bore design for better axial location. The block can be converted from fixed to float by adding or removing the locating rings. A variety of sealing options help protect against contamination including all-purpose elastomer seals, deflection-type V-ring seals, precision labyrinth seals and heavy-duty taconite seals for highly contaminated environments.

TYPICAL INDUSTRIES AND APPLICATIONS

Use Timken SNT plummer blocks in power generation (coal), mining, aggregate, cement, metals, pulp, paper and other forestry operations, water treatment and food processing industries. Applications include warehousing, conveyors, bulk material handling and industrial fans and blowers.





HOW TO USE THIS CATALOG

We designed this catalog to help you find the Timken housed units best suited to your specifications.

Timken offers an extensive range of bearings and accessories in both imperial and metric sizes. For your convenience, size ranges are indicated in millimeters and inches. Contact your Timken engineer to learn more about our complete line for the special needs of your application.

This publication contains dimensions, tolerances and load ratings, as well as engineering sections describing fitting practices for shafts and housings, internal clearances, materials and other bearing features. It provides valuable assistance in the initial consideration of the type and characteristics of the bearings that may best suit your particular needs.

ISO and ANSI/ABMA, as used in this publication, refer to the International Organization for Standardization and the American National Standards Institute/American Bearing Manufacturers Association.

Updates are made periodically to this catalog. Visit www.timken.com for the most recent version of the Timken® Housed Unit Catalog.

DISCLAIMER

This catalog is provided solely to give you analysis tools and data to assist you in your product selection. Product performance is affected by many factors beyond the control of Timken. Therefore, you must validate the suitability and feasibility of all product selections for your applications.

Timken products are sold subject to Timken terms and conditions of sale, which include our limited warranty and remedy. You can find these at <http://www.timken.com/en-us/purchase/Pages/TermsandConditionsofSale.aspx>.

Please consult with your Timken engineer for more information and assistance.

Every reasonable effort has been made to ensure the accuracy of the information in this writing, but no liability is accepted for errors, omissions or for any other reason.

SHELF LIFE AND STORAGE OF GREASE-LUBRICATED BEARINGS AND COMPONENTS

To help you get the most value from our products, Timken provides guidelines for the shelf life of grease-lubricated ball and roller bearings, components and assemblies. Shelf life information is based on Timken and industry test data and experience.

SHELF LIFE POLICY

Shelf life should be distinguished from lubricated bearing/component design life as follows:

- Shelf life of the grease-lubricated bearing/component represents the period of time prior to use or installation.
- The shelf life is a portion of the anticipated aggregate design life. It is impossible to accurately predict design life due to variations in lubricant bleed rates, oil migration, operating conditions, installation conditions, temperature, humidity and extended storage.
- Shelf life values, available from Timken, represent a maximum limit and assume adherence to the storage and handling guidelines suggested in this catalog or by a Timken associate. Deviations from the Timken storage and handling guidelines may reduce shelf life. Any specification or operating practice that defines a shorter shelf life should be used.

Timken cannot anticipate the performance of the grease lubricant after the bearing or component is installed or placed in service.

TIMKEN IS NOT RESPONSIBLE FOR THE SHELF LIFE OF ANY BEARING/COMPONENT LUBRICATED BY ANOTHER PARTY.

European REACH Compliance

Timken lubricants, greases and similar products sold in standalone containers or delivery systems are subject to the European REACH (**R**egistration, **E**valuation, **A**uthorization and **R**estriction of **C**hemicals) directive. For import into the European Union, Timken can sell and provide only those lubricants and greases that are registered with ECHA (**E**uropean **C**hemical **A**gency). For further information, please contact your Timken engineer.



STORAGE

Timken suggests the following storage guidelines for our finished products (bearings, components and assemblies, referred to as “products”):

- Unless directed otherwise by Timken, products should be kept in their original packaging until they are ready to be placed into service.
- Do not remove or alter any labels or stencil markings on the packaging.
- Products should be stored in such a way that the packaging is not pierced, crushed or otherwise damaged.
- After a product is removed from its packaging, it should be placed into service as soon as possible.
- When removing a product that is not individually packaged from a bulk pack container, the container should be resealed immediately after the product is removed.



- Do not use product that has exceeded its shelf life as defined in the Timken shelf life guidelines statement.
- The storage area temperature should be maintained between 0° C (32° F) and 40° C (104° F); temperature fluctuations should be minimized.
- The relative humidity should be maintained below 60 percent and the surfaces should be dry.
- The storage area should be kept free from airborne contaminants such as, but not limited to, dust, dirt, harmful vapors, etc.
- The storage area should be isolated from undue vibration.
- Extreme conditions of any kind should be avoided.



Due to the fact that Timken is not familiar with your particular storage conditions, we strongly suggest following these guidelines. However, you may be required by circumstances or applicable government requirements to adhere to stricter storage requirements.

Most bearing components typically ship protected with a corrosion-preventive compound that is not a lubricant. These components may be used in oil-lubricated applications without removal of the corrosion-preventive compound. When using some specialized grease lubrications, we advise you to remove the corrosion-preventive compound before packing the bearing components with suitable grease.

We pre-pack most housed unit types in this catalog with general-purpose grease suitable for their normal applications. It may be necessary for you to frequently replenish the grease for optimum performance.

Be careful in selecting lubrication, however, since different lubricants are often incompatible. You may order housed units pre-lubricated with a specified lubrication.

When you receive a bearing or housed unit shipment, do not remove products from their packaging until they are ready for mounting so they do not become corroded or contaminated.

Store bearings and housed units in an appropriate atmosphere so they remain protected for the intended period.

**WARNING**

Failure to observe the following warnings could create a risk of death or serious injury.

Proper maintenance and handling practices are critical. Failure to follow selection recommendations and installation instructions and to maintain proper lubrication can result in equipment failure.

Overheated bearings can ignite explosive atmospheres. Special care must be taken to properly select, install, maintain, and lubricate housed unit bearings that are used in or near atmospheres that may contain explosive levels of combustible gases or accumulations of dust such as grain, coal, or other combustible materials. Consult your equipment designer or supplier for installation and maintenance instructions.

If hammer and bar are used for installation or removal of a part, use a mild steel bar (e.g., 1010 or 1020 grade). Mild steel bars are less likely to cause release of high-speed fragments from the hammer, bar or the part being removed.

CAUTION

Failure to follow these cautions may result in property damage.

Do not use damaged housed units.

NOTE

Do not use excessive force when mounting or dismantling the unit.

Follow all tolerance, fit, and torque recommendations.

Always follow the Original Equipment Manufacturer's installation and maintenance guidelines.

Ensure proper alignment.

Never weld housed units.

Do not heat components with an open flame.

Do not operate at bearing temperatures above 121° C (250° F).

Warnings for this product line are in this catalog and posted on www.timken.com/warnings.



**SPHERICAL ROLLER BEARING
SOLID-BLOCK HOUSED UNITS**

Timken® spherical roller bearing solid-block housed units provide heavy-duty protection in harsh environments. Designed to handle high temperatures, high speeds, heavy loads, misalignment, and contaminated conditions, these solid-block housed units are rugged enough to help protect bearings working in tough conditions. With machined feet, tapped puller holes, black oxide inner rings and multiple shaft locking options, these cast-steel housed units are easy to install.

Updates are made periodically to this catalog. Visit www.timken.com for the most recent version of the Timken® Housed Unit Catalog.

TYPICAL INDUSTRIES AND APPLICATIONS

Common industries include metal mills, aggregate and cement, mining, power generation, agriculture, pulp and paper, and sawmills and other forest industries. Applications include material conveying, commercial and industrial building equipment, sugar mill machinery, waste management and water treatment equipment, off-highway and construction vehicles, fans, blowers, cranes, lifts and hoists.

Introduction C-2
 Engineering C-7
 Spherical Roller Bearing Solid-Block Housed Unit
 Product Data Tables C-53



INTRODUCTION

When your equipment faces harsh environments, you need roller bearing housed units that are rugged enough to withstand tough conditions and deliver exceptional performance.

You gain both with Timken spherical roller bearing solid-block housed units.

Designed specifically to perform under extreme conditions, Timken solid-block housed units are able to handle up to ± 1.5 degrees of misalignment and withstand the impact of falling debris. Made of cast-steel housings and Timken® double-row spherical roller bearings, their unique sealing design offers protection from contaminants.

Increased performance and durability helps decrease the overall cost of ownership.

CUSTOMIZABLE DESIGN FEATURES TO FIT YOUR EQUIPMENT

With a full line of precision-made shaft-locking styles, seals and housings, it's easy to find the right housed unit to fit your application. Timken spherical roller bearing solid-block housed units interchange with a wide range of mounted roller bearings. Choose from many primary and secondary sealing mechanisms, and you decide how it's built without paying custom charges.

HOUSING STYLES

- Two-bolt pillow blocks.
- Four-bolt pillow blocks.
- Flange blocks.
- Piloted flanges.
- Cartridges.
- Take-up blocks.
- Cartridge units.

LOCKING STYLES

- Eccentric lock.
- Concentric lock (set screw) – single or double collar.
- Tapered adapter lock.
- V-Lock® double tapered lock – single or double nut.

DuPont™ is a trademark of E.I. du Pont de Nemours and Company.
Teflon® is a registered trademark of E.I. du Pont de Nemours and Company.
Dykor® is a registered trademark of Whitford Corporation.

SEALS

- Labyrinth seals – DuPont™ Teflon®:
 - High-speed applications.
 - Superior in dirty and wet conditions.
 - Able to operate at high temperatures.
 - Resistant to most chemicals.
 - Abrasion-resistant.
- Triple-lip seals – nitrile:
 - Self-purging.
 - Excellent in dirty and wet applications.
 - Chemical- and corrosion-resistant.
- Triple-lip seals – urethane:
 - All the benefits of nitrile, plus resistance to abrasion.

SECONDARY SEALS

- Closed-end covers.
- Open-end covers with:
 - Triple-lip seal.
 - DuPont Teflon.
 - V-ring seal.
- Piloted-flange cartridge backing plates with:
 - Triple-lip seal.
- Flange block backing plates with V-ring seal.

HOUSING COATINGS

- Powder coating – standard.
- Nickel plating – optional.
- Dykor® coating – optional.



Fig. C-1. Two-bolt pillow block.



Fig. C-2. Four-bolt pillow block.

OUTLASTING THE COMPETITION

Timken solid-block housed units last a long time, yet you don't pay extra for reliability. Experience an increase in performance and durability and a decrease in your overall cost of ownership when you use a Timken solid-block housed unit.

STANDS UP TO HARSH CONDITIONS

Protects Bearing. Harsh operating environments and lubrication issues often lead to housed unit bearing damage. Timken solid-block housed units multiply protection with primary and secondary seal options, as well as steel covers in sizes to fit these units. The space between the primary and secondary seals offers a fillable grease cavity for more protection.

Handles Misalignment. Without a properly aligned shaft, the life expectancy of most housed units decreases. However, Timken spherical roller bearing solid-block housed units run efficiently on misaligned shafts up to ± 1.5 degrees, thanks to their unique design and Timken spherical roller bearings.

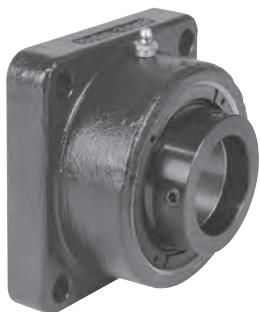

Fig. C-3. Flange block.



Fig. C-4. Take-up block.



Fig. C-5. Piloted-flange cartridge.



Fig. C-6. Cartridge block.

INDUSTRIES AND APPLICATIONS

- Metal mills.
- Aggregate and cement.
- Mining.
- Power generation.
- Sawmills and other forest process industries.
- Pulp and paper.
- Material conveying.
- Commercial and industrial building equipment.
- Sugar mills.
- Agriculture.
- Waste management and water treatment.
- Off-highway and construction vehicles.
- HVAC, fans and blowers.
- Cranes, lifts and hoists.

DEPENDABLE SERVICE

Every Timken spherical roller bearing solid-block housed unit is backed by the service of our industry-leading experts who are ready to assist you with product design, application knowledge and field engineering support – anything you need to help improve uptime and maximize equipment performance.

LOCKING STYLES

V-LOCK® (DOUBLE-TAPERED LOCK) U.S. PAT. NO. 7344313

The V-Lock locking mechanism is excellent in high-speed applications and designed to maximize shaft-holding power and minimize the time needed for installation and removal as compared to conventional locking mechanisms. With no need for feeler gages during installation, the V-Lock locking mechanism offers superior holding power and is designed to eliminate overtightening. Mechanical withdrawal is a feature of double-nut units.

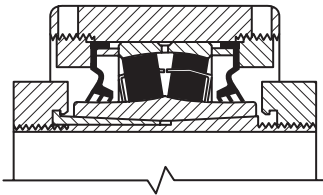

Fig. C-7. V-Lock®.

CONCENTRIC LOCK (SET SCREW) – CL SERIES

Two set screws positioned at 60 degrees provide aggressive holding power. When configured with a double-collared insert, the bearing provides double the holding power compared to our standard single-collared insert.

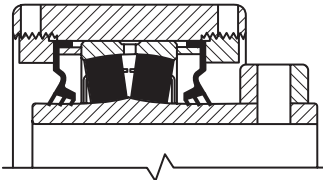

Fig. C-8. Single set screw lock.

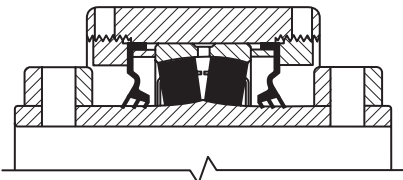

Fig. C-9. Double set screw lock.

ECCENTRIC LOCK – EC SERIES

A reduced eccentric offset results in more mechanical advantage. This series provides a secure lock that should not release from a properly prepared shaft even in reversing applications.

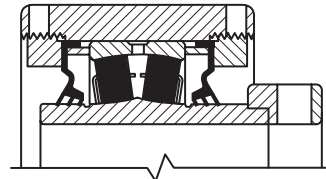

Fig. C-10. Eccentric lock.

TAPERED ADAPTER LOCK – TA/DV SERIES

Excellent in high-load applications, this design uses a longer 2300-series adapter for increased shaft contact. This design offers the best shaft concentricity and highest capacity all while having the ability to accommodate undersized shafting.

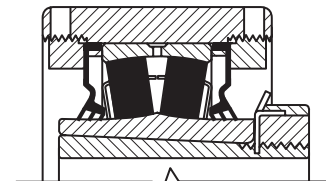

Fig. C-11. Tapered adapter lock.

HOUSING COATINGS

POWDER COATING – STANDARD

All of our steel housings come powder-coated from the factory. Powder coating gives a hard finish that is tough and durable.

NICKEL PLATING – OPTIONAL

By nickel plating any of our housings, we are able to offer superior resistance to wear and corrosion.

DYKOR® COATING – OPTIONAL

Unaffected by most chemicals and solvents, Dykor coating is designed to last in harsh chemical environments while having extreme abrasion resistance.

Dykor® is a registered trademark of Whitford Corporation.

SOLID-BLOCK HOUSED UNIT BENEFITS

Depending on how you configure your bearing for a specific application, there's a wide range of product benefits.

- Multiple available sizes accommodate shaft diameters from 35 mm to 180 mm (1 7/16 in. to 7 in.).
- Efficient built-to-order manufacturing. Quick delivery of customized configurations for specific applications.
- Quicker installation. Machined feet, tapped puller holes, black oxide inner rings and multiple shaft-locking choices make it simpler to install this heavy-duty unit.
- Improved performance in high-contaminant environments. Wide selection of primary and secondary seals, as well as auxiliary covers.
- Bidirectional shaft expansion. Double-nut housing feature allows expansion in both directions.
- Increased uptime. Robust steel housing, a wide variety of seal choices and a high-performance Timken spherical roller bearing result in increased unit uptime.
- Increased shaft holding power and reduced shaft damage. Eccentric lock series is designed to stay tight in reversing applications on precision-ground shafts.
- Fewer misalignment issues. Bearings accept up to ±1.5 degrees of misalignment.
- Protection against over-lubrication. Pressure relief valves come standard when unit is ordered with non-purgeable seals.
- Dimensionally interchanges with a wide range of other mounted roller bearing units.
- One-time shaft alignment on all housing unit styles. Machined feet ends allow for precise installation and blocking for faster future unit replacement.
- Easier removal with standard withdrawal holes on all piloted-flange units.
- Faster and easier changeover thanks to a comprehensive product offering that interchanges with virtually all solid-block roller bearing units.

NOTE

Do not use excessive force when mounting or dismounting the unit.

Follow all tolerance, fit and torque recommendations.

Always follow the Original Equipment Manufacturer's installation and maintenance guidelines.

Ensure proper alignment.

Never weld housed units.

Do not heat components with an open flame.

Do not operate at bearing temperatures above 121°C (250°F).

Updates are made periodically to this catalog. Visit www.timken.com for the most recent version of the Timken® Housed Unit Catalog.



WARNING

Failure to observe the following warnings could create a risk of death or serious injury.

Proper maintenance and handling practices are critical. Always follow installation instructions and maintain proper lubrication.

Overheated bearings can ignite explosive atmospheres. Special care must be taken to properly select, install, maintain, and lubricate housed unit bearings that are used in or near atmospheres that may contain explosive levels of combustible gases or accumulations of dust such as from grain, coal, or other combustible materials. Consult your equipment designer or supplier for installation and maintenance instructions.



CAUTION

Failure to follow these cautions could create a risk of injury.

Do not use damaged housed units. The use of a damaged housed unit can result in equipment damage and/or injury.

CAUTION

Failure to follow these cautions may result in property damage.

If hammer and bar are used for installation or removal of a part, use a mild steel bar (e.g., 1010 or 1020 grade). Mild steel bars are less likely to cause release of high-speed fragments from the hammer, bar or the part being removed.

Warnings for this product line are in this catalog and posted on www.timken.com/en-us/products/warnings/Pages/TimkenHousedUnitWarnings.aspx.

DISCLAIMER

This catalog is provided solely to give you analysis tools and data to assist you in your product selection. Product performance is affected by many factors beyond the control of Timken. Therefore, you must validate the suitability and feasibility of all product selections for your applications.

Timken products are sold subject to Timken terms and conditions of sale, which include our limited warranty and remedy. You can find these at <http://www.timken.com/en-us/purchase/Pages/TermsandConditionsofSale.aspx>.

Please consult with your Timken engineer for more information and assistance.

Every reasonable effort has been made to ensure the accuracy of the information in this writing, but no liability is accepted for errors, omissions or for any other reason.

SOLID-BLOCK HOUSED UNIT DESIGN

Flexibility through interchangeable components.

Double-row spherical roller bearing accepts misalignment.

Black oxide inner ring reduces shaft fretting corrosion.

Six primary seals in any combination:

- T seal standard labyrinth (DuPont™ Teflon®).
- M seal standard lip (nitrile rubber).
- N seal optional (DuPont™ Viton®).
- O seal optional (urethane).
- B seal optional (nitrile rubber).
- C seal optional (DuPont Viton).

Housing fit: J7, size-for-size to light interference.

Standard relief valve.

Optional bolt-on open and closed steel or urethane secondary seals.

Lubricated with premium industrial grease.

Five shaft-locking styles:

- Single screw set.
- Double screw set.
- Eccentric.
- Tapered adapter.
- V-Lock®.

Machined feet aid in rapid installation and alignment.

Easily converted to fixed or expansion in the field.

Housing can be supplied with powder (standard), nickel or Dykor® coatings.

Housing manufactured from 75000 psi tensile cast steel that retains the bearing-to-housing fit for those rough applications.

Fig. C-12. High performance plus superior ruggedness.

DuPont™ is a trademark of E.I. du Pont de Nemours and Company.
 Teflon® is a registered trademark of E.I. du Pont de Nemours and Company.
 Viton® is a registered trademark of E.I. du Pont de Nemours and Company.
 Dykor® is a registered trademark of Whitford Corporation.

ENGINEERING

The following topics are covered within this engineering section:

Bearing Load	C-8
Normal Speed Ratings for Seals	C-25
Seal Material Chemical Compatibility	C-28
Internal Radial Clearance	C-30
Shafting	C-32
Misalignment	C-33
Lubrication	C-33
Installation Guides	C-34

To view the complete engineering catalog, please visit www.timken.com. To order the catalog, please contact your Timken engineer and request a copy of the Timken Engineering Manual, order number 10424.

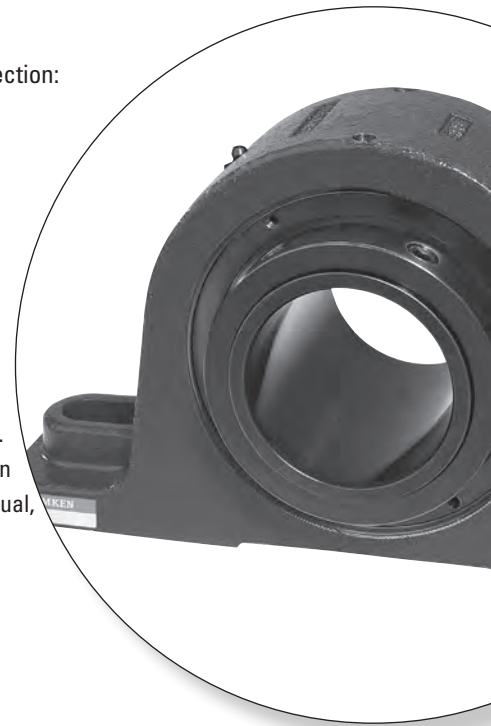

BEARING LOAD

Solid-block housed unit bearings are excellent for many applications including those with:

- Heavy radial loads.
- Heavy combined radial and thrust loads.
- Shock loads.
- Harsh contamination conditions.
- Low to moderate speeds.
- The possibility of misalignment.

Bearing loads generally come from one of three sources that should all be evaluated and considered when selecting steel housed unit bearings for your application. Contact your Timken engineer for assistance in determining specific application loads and for bearing recommendations.

- Static loads – weights of various components supported by the bearings.
- Drive loads – belts, chains or gears that exert forces on the shaft.
- Imposed loads – forces generated by equipment operation.

Generally, bearing loads are described as being radial (load perpendicular to the axis of the shaft) or axial (load parallel to the axis of the shaft). Axial loads also are referred to as thrust loads. Spherical roller bearings, by design, are very capable of accepting heavy radial loads, even when combined with a thrust load. Timken® Type E housed units are recommended for use in applications when only thrust loads are present or when the thrust component of the load is larger than the radial component.

To determine the allowable radial load at various RPMs for bearings supporting only radial loads, simply use the charts on pages C-10 – C-23. For bearings supporting both radial and thrust loads, an equivalent radial load must first be calculated prior to using these tables (see DYNAMIC EQUIVALENT RADIAL LOAD on page C-9).

BELT LOADS

V-belt drives are common sources of drive loads. A good approximation of drive load may be calculated from the formula:

$$\text{Drive Load} = (\text{HP} \times 189000) / (\text{Pulley Diameter} \times \text{RPM})$$

$$\text{Drive Load} = (\text{KW} \times 189000) / (\text{Pulley Diameter} \times \text{RPM})$$

LOAD SHARING

In some cases, bearings may share the load unequally, depending on their position in relationship to the load. Use the appropriate formula below to determine the drive load on each bearing:

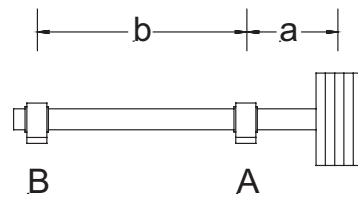

$$\text{Load A} = \text{Drive Load} \times (a + b) / b$$

$$\text{Load B} = \text{Drive Load} \times a / b$$

Fig. C-13. Overhung load.

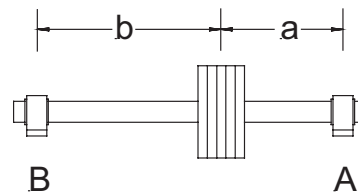

$$\text{Load A} = (\text{Drive Load} \times b) / (a + b)$$

$$\text{Load B} = (\text{Drive Load} \times a) / (a + b)$$

Fig. C-14. Load between bearings.

DYNAMIC EQUIVALENT RADIAL LOAD

Bearings that support a combination of radial load and thrust load take an unequal load on one of the rows of rollers. The following formulas and bearing geometry factors are used to convert the independent thrust and radial loads into a single equivalent radial load. The calculated dynamic equivalent radial load (P_r) will have the same effect on bearing life (L_{10}) as a radial load of the same magnitude.

$$P_r = F_r + (Y1 \times F_a) \text{ when } F_a/F_r \leq e$$

$$P_r = (0.67 \times F_r) + (Y2 \times F_a) \text{ when } F_a/F_r > e$$

where:

P_r = Dynamic equivalent radial load
 F_r = Applied radial load (lbs., N)
 F_a = Applied thrust (axial) load (lbs., N)
 $Y1$, $Y2$ and e are bearing geometry factors shown on pages C-10 and C-11.

BEARING CALCULATED LIFE

Customers select the bearing life of the bearings in equipment they are building. In the absence of a customer bearing life target, the following may be considered as a guideline:

- If the customer's machinery operates eight hours a day, then use a bearing life target of 20000 to 30000 hours.
- If the customer's machinery operates 24 hours a day, then use a bearing life target of 40000 to 60000 hours.

In addition, a service factor may be used where application conditions are harsh. Extreme environmental conditions or heavy shock or vibration will require the adjustment of load ratings before referring to the L_{10} tables. Please contact your Timken engineer for additional information.

Standard spherical roller bearing life calculation:

$$\text{Bearing life} = L_{10} = (C/P_r)^{10/3} \times (16667/\text{RPM})$$

where:

C = Dynamic capacity (lbs., N)
 P_r = Radial load/dynamic equivalent radial load
 RPM = Revolutions per minute

DISCLAIMER

This catalog is provided solely to give you analysis tools and data to assist you in your product selection. Product performance is affected by many factors beyond the control of timken. Therefore, the suitability and feasibility of all product selection must be validated by you.

TERMS AND CONDITIONS

Timken products are sold subject to our terms and conditions of sale, which include its limited warranty and remedy, which terms may be found at <http://www.timken.com/en-us/purchase/pages/termsandconditionsofsale.aspx>.

Please consult with your Timken engineer for more information and assistance.

A NOTE ON MINIMUM LOADS

In order for a spherical roller bearing to perform as designed, some radial load should be present. This is particularly true if the bearing is running at high speed. Although it is rarely an issue, as the existing static loads (weights of the combined supported components) usually provide an adequate radial load, there are times when it may be necessary to use a shaft diameter larger than the actual loads require. In these instances, the load becomes a small percentage of the bearing's capacity. Radial loads less than 4 percent of C should be avoided.

BEARING RADIAL AND THRUST FACTORS

TABLE C-1. V-LOCK® SERIES (TAPERED BORE, C3)

Shaft Dia.	Bearing No.	Dynamic Capacity C	Static Capacity C ₀	Equivalent Radial Load Factors		
				e	Y1	Y2
mm in.		kN lbs.	kN lbs.			
50 1 15/16, 2	22211	140 31400	142 31900	0.23	2.95	4.40
55 2 3/16, 2 1/4	22212	169 38100	174 39000	0.24	2.84	4.23
55 2 3/16, 2 1/4	22213	206 46400	216 48600	0.24	2.79	4.15
60, 65 2 7/16, 2 1/2	22214	213 47800	231 52000	0.23	2.90	4.32
60, 65 2 7/16, 2 1/2	22215	222 49900	240 54100	0.22	3.14	4.67
70, 75 2 11/16, 2 3/4, 2 15/16, 3	22216	254 57200	278 62500	0.22	3.14	4.67
70, 75 2 11/16, 2 3/4, 2 15/16, 3	22217	297 66900	320 71900	0.22	3.07	4.57
80, 85, 90 3 3/16, 3 1/4, 3 7/16, 3 1/2	22219	385 86600	441 99000	0.23	2.88	4.29
80, 85, 90 3 3/16, 3 1/4, 3 7/16, 3 1/2	22220	435 97700	502 113000	0.24	2.85	4.24
100 3 11/16, 3 3/4, 3 15/16, 4	22222	555 125000	653 147000	0.25	2.73	4.06
110 —	22224	647 145000	772 174000	0.25	2.70	4.02
110, 115 4 7/16, 4 1/2	22226	757 170000	945 212000	0.26	2.62	3.90
125, 130 4 15/16, 5	22228	863 194000	1060 237000	0.25	2.67	3.98

TABLE C-2. CL SERIES (STRAIGHT BORE, C NORMAL)

Shaft Dia.	Bearing No.	Dynamic Capacity C	Static Capacity C ₀	Equivalent Radial Load Factors		
				e	Y1	Y2
mm in.		kN lbs.	kN lbs.			
35 1 7/16, 1 1/2	22208	104 23400	99.7 22400	0.27	2.47	3.67
40, 45 1 11/16, 1 3/4	22209	109 24500	108 24200	0.26	2.64	3.93
50 1 15/16, 2	22210	117 26300	118 26600	0.24	2.84	4.23
55 2 3/16, 2 1/4	22211	140 31400	142 31900	0.23	2.95	4.40
60, 65 2 7/16, 2 1/2	22213	206 46400	216 48600	0.24	2.79	4.15
70, 75 2 11/16, 2 3/4, 2 15/16, 3	22215	222 49900	240 54100	0.22	3.14	4.67
80, 85, 90 3 3/16, 3 1/4, 3 7/16, 3 1/2	22218	355 79700	388 87200	0.23	2.90	4.31
100 3 15/16, 4	22220	435 97700	502 113000	0.24	2.85	4.24
110, 115 4 7/16, 4 1/2	22222	555 125000	653 147000	0.25	2.73	4.06
125, 130 4 15/16, 5	22226	757 170000	945 212000	0.26	2.62	3.90

TABLE C-3. EC SERIES (STRAIGHT BORE, C NORMAL)

Shaft Dia.	Bearing No.	Dynamic Capacity C	Static Capacity C ₀	Equivalent Radial Load Factors		
				e	Y1	Y2
mm in.		kN lbs.	kN lbs.			
35 1 7/16, 1 1/2	22208	104 23400	99.7 22400	0.27	2.47	3.67
40, 45 1 11/16, 1 3/4	22209	109 24500	108 24200	0.26	2.64	3.93
50 1 15/16, 2	22210	117 26300	118 26600	0.24	2.84	4.23
55 2 3/16, 2 1/4	22211	140 31400	142 31900	0.23	2.95	4.40
60, 65 2 7/16, 2 1/2	22213	206 46400	216 48600	0.24	2.79	4.15
70, 75 2 11/16, 2 3/4, 2 15/16, 3	22215	220 49900	240 54100	0.22	3.14	4.67
80, 85, 90 3 3/16, 3 1/4, 3 7/16, 3 1/2	22218	355 79700	388 87200	0.23	2.90	4.31
100 3 11/16, 3 3/4, 3 15/16, 4	22220	435 97700	502 113000	0.24	2.85	4.24
110, 115 4 7/16, 4 1/2	22222	555 125000	653 147000	0.25	2.73	4.06
125, 130 4 15/16, 5	22226	757 170000	945 212000	0.26	2.62	3.90
140, 150 5 7/16, 5 1/2, 5 15/16, 6	23230	1270 286000	1660 372000	0.32	2.08	3.10
170, 180 6 7/16, 6 1/2, 6 15/16, 7	23234	1660 373000	2200 494000	0.33	2.08	3.09

TABLE C-4. TA/DV SERIES (TAPERED BORE, C3)

Shaft Dia.	Bearing No.	Dynamic Capacity C	Static Capacity C ₀	Equivalent Radial Load Factors		
				e	Y1	Y2
mm in.		kN lbs.	kN lbs.			
40 1 7/16, 1 1/2	22209	109 24500	108 24200	0.26	2.64	3.93
45 1 11/16, 1 3/4	22210	117 26300	118 26600	0.24	2.84	4.23
50 1 15/16, 2	22211	140 31400	142 31900	0.23	2.95	4.40
55 —	22212	169 38100	174 39000	0.24	2.84	4.23
60 2 3/16, 2 1/4	22213	206 46400	216 48600	0.24	2.79	4.15
65 2 7/16, 2 1/2	22215	222 49900	240 54100	0.22	3.14	4.67
70 2 11/16, 2 3/4	22216	254 57200	278 62500	0.22	3.14	4.67
75 2 15/16, 3	22217	297 66900	320 71900	0.22	3.07	4.57
80 3 3/16, 3 1/4	22218	355 79700	388 87200	0.23	2.90	4.31
85 —	22219	385 86600	441 99000	0.23	2.88	4.29
90 3 7/16, 3 1/2	22220	435 97700	502 113000	0.24	2.85	4.24
100 3 15/16, 4	22222	555 125000	653 147000	0.25	2.73	4.06
110 4 3/16, 4 1/4	22224	647 145000	772 174000	0.25	2.70	4.02
115 4 7/16, 4 1/2	22226	757 170000	945 212000	0.26	2.62	3.90
125 4 15/16, 5	22228	863 194000	1060 237000	0.25	2.67	3.98

SPHERICAL ROLLER BEARING SOLID-BLOCK HOUSED UNITS

ENGINEERING • BEARING LOAD

LOAD RATINGS

TABLE C-5. V-LOCK SERIES – ALLOWABLE RADIAL LOAD (kN/LBS.) AT VARIOUS RPM⁽¹⁾

Shaft Diameter	Bearing No.	C	L ₁₀ Life	Speed ⁽²⁾																
				RPM																
mm in.		kN lbs.		50	100	200	500	1000	1200	1500	1800	2100	2400	2700	3000	3200	3500 ⁽¹⁾			
50 1 15/16, 2	22211	140 31400	10000	50.3 11319	40.9 9194	33.2 7468	25.2 5673	20.5 4608	19.4 4362	18.1 4080	17.2 3863	16.4 3688	15.8 3543	15.2 3420	14.7 3314	14.5 3250	14.1 3164			
			30000	36.2 8141	29.4 6612	23.9 5371	18.1 4080	14.7 3314	14.0 3138	13.1 2934	12.4 2778	11.8 2653	11.3 2549	10.9 2460	10.6 2383	10.4 2338	10.4 2338	10.4 2338	10.1 2276	
			40000	33.2 7468	27.0 6066	21.9 4927	16.6 3743	13.5 3040	12.8 2878	12.0 2692	11.3 2549	10.8 2433	10.4 2338	10.0 2257	9.7 2186	9.5 2144	9.5 2144	9.5 2144	9.5 2144	9.3 2088
			60000	29.4 6612	23.9 5371	19.4 4362	14.7 3314	12.0 2692	11.3 2549	10.6 2383	10.0 2257	9.6 2155	9.2 2070	8.9 1998	8.6 1936	8.4 1899	8.4 1899	8.4 1899	8.4 1899	8.2 1849
			100000	25.2 5673	20.5 4608	16.6 3743	12.6 2843	10.3 2309	9.7 2186	9.1 2045	8.6 1936	8.2 1849	7.9 1776	7.6 1714	7.4 1661	7.4 1661	7.4 1661	7.4 1661	7.4 1661	7.2 1629
				50	100	200	500	1000	1200	1500	1800	2100	2400	2700	3000	3200 ⁽¹⁾	3500 ⁽¹⁾			
55 2 3/16, 2 1/4	22212	169 38100	10000	61.1 13734	49.6 11155	40.3 9061	30.6 6883	24.9 5591	23.5 5293	22.0 4951	20.8 4687	19.9 4475	19.1 4300	18.5 4150	17.9 4021	17.5 3944	17.1 3839			
			30000	43.9 9878	35.7 8023	29.0 6517	22.0 4951	17.9 4021	16.9 3807	15.8 3561	15.0 3371	14.3 3219	13.8 3092	13.3 2985	12.9 2892	12.6 2837	12.6 2837	12.3 2761		
			40000	40.3 9061	32.7 7360	26.6 5978	20.2 4541	16.4 3689	15.5 3492	14.5 3266	13.8 3092	13.1 2953	12.6 2837	12.2 2738	11.8 2653	11.6 2602	11.6 2602	11.6 2602	11.3 2533	
			60000	35.7 8023	29.0 6517	23.5 5293	17.9 4021	14.5 3266	13.8 3092	12.9 2892	12.2 2738	11.6 2614	11.2 2512	10.8 2425	10.4 2349	10.2 2304	10.2 2304	10.2 2304	10.0 2243	
			100000	30.6 6883	24.9 5591	20.2 4541	15.3 3450	12.5 2802	11.8 2653	11.0 2481	10.4 2349	10.0 2243	9.6 2155	9.3 2080	9.0 2015	8.8 1977	8.8 1977	8.8 1977	8.6 1924	
				50	100	200	500	1000	1200	1500	1800	2100	2400	2700	3000 ⁽¹⁾	3200 ⁽¹⁾	3500 ⁽¹⁾			
55 2 3/16, 2 1/4	22213	206 46400	10000	74.4 16726	60.4 13585	49.1 11035	37.3 8383	30.3 6809	28.7 6446	26.8 6029	25.4 5708	24.2 5450	23.3 5236	22.5 5054	21.8 4897	21.4 4803	20.8 4676			
			30000	53.5 12030	43.5 9771	35.3 7937	26.8 6029	21.8 4897	20.6 4636	19.3 4336	18.3 4105	17.4 3920	16.8 3766	16.2 3635	15.7 3522	15.4 3455	15.4 3455	15.0 3363		
			40000	49.1 11035	39.9 8963	32.4 7280	24.6 5531	20.0 4492	18.9 4253	17.7 3978	16.8 3766	16.0 3596	15.4 3455	14.8 3335	14.4 3231	14.1 3169	14.1 3169	13.7 3085		
			60000	43.5 9771	35.3 7937	28.7 6446	21.8 4897	17.7 3978	16.8 3766	15.7 3522	14.8 3335	14.2 3184	13.6 3059	13.1 2953	12.7 2861	12.5 2806	12.5 2806	12.2 2732		
			100000	37.3 8383	30.3 6809	24.6 5531	18.7 4201	15.2 3413	14.4 3231	13.4 3022	12.7 2861	12.2 2732	11.7 2624	11.3 2533	10.9 2454	10.7 2407	10.7 2407	10.4 2343		
				50	100	200	500	1000	1200	1500	1800	2100	2400	2700 ⁽¹⁾	3000 ⁽¹⁾	3200 ⁽¹⁾				
60, 65 2 7/16, 2 1/2	22214	213 47800	10000	76.6 17230	62.3 13995	50.6 11368	38.4 8636	31.2 7014	29.5 6641	27.6 6211	26.2 5880	25.0 5615	24.0 5394	23.2 5207	22.4 5045	22.0 4948				
			30000	55.1 12392	44.8 10066	36.4 8176	27.6 6211	22.4 5045	21.2 4776	19.9 4467	18.8 4229	18.0 4038	17.3 3880	16.7 3745	16.1 3628	15.8 3559	15.8 3559			
			40000	50.6 11368	41.1 9234	33.4 7500	25.3 5697	20.6 4628	19.5 4381	18.2 4098	17.3 3880	16.5 3704	15.8 3559	15.3 3435	14.8 3328	14.5 3265	14.5 3265			
			60000	44.8 10066	36.4 8176	29.5 6641	22.4 5045	18.2 4098	17.3 3880	16.1 3628	15.3 3435	14.6 3280	14.0 3151	13.5 3042	13.1 2947	12.9 2891	12.9 2891			
			100000	38.4 8636	31.2 7014	25.3 5697	19.3 4328	15.6 3515	14.8 3328	13.8 3113	13.1 2947	12.5 2814	12.0 2703	11.6 2610	11.2 2528	11.0 2480	11.0 2480			

⁽¹⁾Speeds referenced here may be higher than speed rating for seals. Please refer to the charts on pages C-25 and C-26.

⁽²⁾For speeds greater than thermal reference speed, contact your Timken engineer.

Continued on next page.

SPHERICAL ROLLER BEARING SOLID-BLOCK HOUSED UNITS

ENGINEERING • BEARING LOAD

Continued from previous page.

Shaft Diameter	Bearing No.	C	L ₁₀ Life	Speed ⁽²⁾													
				RPM													
mm in.		kN lbs.		50	100	200	500	1000	1200	1500	1800	2100	2400	2700 ⁽¹⁾	3000 ⁽¹⁾	3200 ⁽¹⁾	
60, 65 2 7/16, 2 1/2	22215	222 49900	10000	80.0 17987	65.0 14610	52.8 11867	40.1 9015	32.6 7322	30.8 6933	28.8 6484	27.3 6139	26.1 5861	25.0 5631	24.2 5436	23.4 5266	23.0 5166	
			30000	57.5 12937	46.7 10508	38.0 8535	28.8 6484	23.4 5266	22.2 4986	20.7 4663	19.6 4415	18.8 4216	18.0 4050	17.4 3909	16.8 3788	16.5 3715	
			40000	52.8 11867	42.9 9639	34.8 7829	26.5 5948	21.5 4831	20.3 4574	19.0 4278	18.0 4050	18.0 3788	17.2 3586	16.5 3475	16.0 3586	15.5 3475	15.2 3408
			60000	46.7 10508	38.0 8535	30.8 6933	23.4 5266	19.0 4278	18.0 4050	16.8 3788	16.0 3586	15.2 3424	14.6 3290	14.1 3175	13.7 3077	13.4 3018	
			100000	40.1 9015	32.6 7322	26.5 5948	20.1 4518	16.3 3670	15.5 3475	14.5 3250	13.7 3077	13.1 2938	12.6 2822	12.1 2724	11.7 2639	11.5 2589	
				50	100	200	500	1000	1200	1500	1800	2100	2400 ⁽¹⁾	2700 ⁽¹⁾	3000 ⁽¹⁾		
70, 75 2 11/16, 2 3/4, 2 15/16, 3	22216	254 57200	10000	91.7 20619	74.5 16748	60.5 13603	46.0 10334	37.3 8394	35.4 7947	33.1 7432	31.3 7037	29.9 6719	28.7 6455	27.7 6231	26.9 6037		
			30000	66.0 14829	53.6 12045	43.5 9784	33.1 7432	26.9 6037	25.4 5716	23.8 5346	22.5 5061	21.5 4832	20.7 4643	19.9 4481	19.3 4342		
			40000	60.5 13603	49.1 11049	39.9 8975	30.3 6818	24.6 5538	23.3 5243	21.8 4904	20.7 4643	19.7 4433	18.9 4259	18.3 4111	17.7 3983		
			60000	53.6 12045	43.5 9784	35.4 7947	26.9 6037	21.8 4904	20.7 4643	19.3 4342	18.3 4111	17.5 3925	16.8 3771	16.2 3640	15.7 3527		
			100000	46.0 10334	37.3 8394	30.3 6818	23.0 5179	18.7 4207	17.7 3983	16.6 3725	15.7 3527	15.0 3367	14.4 3235	13.9 3123	13.5 3026		
				50	100	200	500	1000	1200	1500	1800	2100 ⁽¹⁾	2400 ⁽¹⁾	2700 ⁽¹⁾			
70, 75 2 11/16, 2 3/4, 2 15/16, 3	22217	297 66900	10000	107.3 24115	87.1 19588	70.8 15910	53.8 12086	43.7 9817	41.3 9295	38.7 8693	36.6 8230	35.0 7858	33.6 7550	32.4 7287			
			30000	77.1 17344	62.7 14088	50.9 11443	38.7 8693	31.4 7061	29.7 6685	27.8 6252	26.3 5919	25.1 5652	24.2 5430	23.3 5241			
			40000	70.8 15910	57.5 12923	46.7 10497	35.5 7974	28.8 6477	27.3 6132	25.5 5735	24.2 5430	23.1 5184	22.2 4981	21.4 4808			
			60000	62.7 14088	50.9 11443	41.3 9295	31.4 7061	25.5 5735	24.2 5430	22.6 5078	21.4 4808	20.4 4591	19.6 4410	18.9 4257			
			100000	53.8 12086	43.7 9817	35.5 7974	26.9 6057	21.9 4920	20.7 4658	19.4 4357	18.3 4125	17.5 3938	16.8 3784	16.2 3652			
				50	100	200	500	1000	1200	1500	1800	2100 ⁽¹⁾	2400 ⁽¹⁾	2700 ⁽¹⁾			
80, 85, 90 3 3/16, 3 1/4, 3 7/16, 3 1/2	22219	385 86600	10000	138.9 31216	112.8 25356	91.6 20595	69.6 15645	56.5 12708	53.5 12032	50.1 11252	47.4 10654	45.2 10172	43.5 9773	42.0 9433			
			30000	99.9 22452	81.1 18236	65.9 14813	50.1 11252	40.7 9140	38.5 8653	36.0 8093	34.1 7662	32.5 7316	31.3 7029	30.2 6785			
			40000	91.6 20595	74.4 16729	60.4 13588	45.9 10322	37.3 8384	35.3 7938	33.0 7424	31.3 7029	29.9 6711	28.7 6448	27.7 6224			
			60000	81.1 18236	65.9 14813	53.5 12032	40.7 9140	33.0 7424	31.3 7029	29.2 6574	27.7 6224	26.4 5942	25.4 5709	24.5 5511			
			100000	69.6 15645	56.5 12708	45.9 10322	34.9 7841	28.3 6369	26.8 6030	25.1 5640	23.7 5339	22.7 5098	21.8 4898	21.0 4728			

⁽¹⁾Speeds referenced here may be higher than speed rating for seals. Please refer to the charts on pages C-25 and C-26.

⁽²⁾For speeds greater than thermal reference speed, contact your Timken engineer.

Continued on next page.

SPHERICAL ROLLER BEARING SOLID-BLOCK HOUSED UNITS

ENGINEERING • BEARING LOAD

LOAD RATINGS – *continued*

TABLE C-5. V-LOCK SERIES – ALLOWABLE RADIAL LOAD (kN/LBS.) AT VARIOUS RPM⁽¹⁾ – *continued*

Shaft Diameter	Bearing No.	C	L ₁₀ Life	Speed ⁽²⁾										
				RPM										
mm in.		kN lbs.		50	100	200	500	1000	1200	1500	1800 ⁽¹⁾	2100 ⁽¹⁾	2400 ⁽¹⁾	2700 ⁽¹⁾
80, 85, 90 3 3/16, 3 1/4, 3 7/16, 3 1/2	22220	435 97700	10000	156.7 35218	127.2 28606	103.4 23235	78.5 17651	63.8 14337	60.4 13574	56.5 12695	53.5 12019	51.0 11476	49.0 11025	47.3 10642
			30000	112.7 25329	91.5 20574	74.3 16711	56.5 12695	45.9 10311	43.4 9762	40.6 9130	38.5 8644	36.7 8254	35.3 7930	34.0 7654
			40000	103.4 23235	84.0 18873	68.2 15329	51.8 11645	42.1 9459	39.8 8955	37.3 8375	35.3 7930	33.7 7571	32.4 7274	31.2 7021
			60000	91.5 20574	74.3 16711	60.4 13574	45.9 10311	37.3 8375	35.3 7930	33.0 7416	31.2 7021	29.8 6704	28.7 6441	27.7 6217
			100000	78.5 17651	63.8 14337	51.8 11645	39.3 8846	32.0 7185	30.3 6803	28.3 6362	26.8 6024	25.6 5752	24.6 5526	23.7 5334
				50	100	200	500	1000	1200	1500 ⁽¹⁾	1800 ⁽¹⁾	2100 ⁽¹⁾	2400 ⁽¹⁾	
100 3 11/16, 3 3/4, 3 15/16, 4	22222	555 125000	10000	200.4 45058	162.8 36599	132.2 29727	100.5 22583	81.6 18343	77.3 17367	72.2 16242	68.4 15377	65.3 14683	62.7 14106	
			30000	144.2 32407	117.1 26323	95.1 21381	72.2 16242	58.7 13193	55.6 12490	52.0 11682	49.2 11060	47.0 10560	45.1 10145	
			40000	132.2 29727	107.4 24146	87.2 19613	66.3 14899	53.8 12102	51.0 11458	47.7 10716	45.1 10145	43.1 9687	41.4 9306	
			60000	117.1 26323	95.1 21381	77.3 17367	58.7 13193	47.7 10716	45.1 10145	42.2 9488	40.0 8983	38.2 8577	36.7 8241	
			100000	100.5 22583	81.6 18343	66.3 14899	50.3 11318	40.9 9193	38.7 8704	36.2 8140	34.3 7707	32.7 7359	31.4 7070	
				50	100	200	500	1000	1200	1500	1800	2100	2400	
110 –	22224	647 145000	10000	232.5 52268	188.8 42455	153.4 34484	116.5 26196	94.6 21278	89.6 20145	83.8 18841	79.3 17838	75.8 17032	72.8 16363	
			30000	167.2 37592	135.8 30534	110.3 24802	83.8 18841	68.1 15303	64.5 14489	60.3 13551	57.1 12829	54.5 12250	52.4 11769	
			40000	153.4 34484	124.6 28010	101.2 22751	76.9 17283	62.4 14038	59.1 13291	55.3 12430	52.4 11769	50.0 11237	48.0 10796	
			60000	135.8 30534	110.3 24802	89.6 20145	68.1 15303	55.3 12430	52.4 11769	49.0 11007	46.4 10421	44.3 9950	42.5 9559	
			100000	116.5 26196	94.6 21278	76.9 17283	58.4 13129	47.4 10664	44.9 10097	42.0 9443	39.8 8940	38.0 8536	36.5 8201	

⁽¹⁾Speeds referenced here may be higher than speed rating for seals. Please refer to the charts on pages C-25 and C-26.

⁽²⁾For speeds greater than thermal reference speed, contact your Timken engineer.

Continued on next page.

Continued from previous page.

Shaft Diameter	Bearing No.	C	L ₁₀ Life	Speed ⁽²⁾									
				RPM									
mm in.		kN lbs.		50	100	200	500	1000	1200 ⁽¹⁾	1500 ⁽¹⁾	1800 ⁽¹⁾	2100 ⁽¹⁾	
110, 115 4 7/16, 4 1/2	22226	757 170000	10000	272.6 61279	221.4 49774	179.8 40429	136.6 30712	111.0 24946	105.1 23618	98.3 22089	93.0 20913	88.8 19968	
			30000	196.1 44074	159.2 35799	129.3 29078	98.3 22089	79.8 17942	75.6 16987	70.7 15887	66.9 15041	63.9 14362	
			40000	179.8 40429	146.1 32839	118.6 26673	90.1 20263	73.2 16458	69.3 15582	64.8 14573	61.4 13798	58.6 13174	
			60000	159.2 35799	129.3 29078	105.1 23618	79.8 17942	64.8 14573	61.4 13798	57.4 12904	54.3 12217	51.9 11665	
			100000	136.6 30712	111.0 24946	90.1 20263	68.5 15393	55.6 12503	52.7 11837	49.2 11071	46.6 10482	44.5 10008	
125, 130 4 15/16, 5	22228	863 194000	10000	311.1 69931	252.7 56801	205.2 46137	155.9 35048	126.6 28468	119.9 26953	112.1 25208	106.2 23866		
			30000	223.7 50296	181.7 40853	147.6 33183	112.1 25208	91.1 20475	86.2 19385	80.6 18130	76.4 17165		
			40000	205.2 46137	166.7 37475	135.4 30439	102.9 23123	83.5 18782	79.1 17782	74.0 16631	70.0 15746		
			60000	181.7 40853	147.6 33183	119.9 26953	91.1 20475	74.0 16631	70.0 15746	65.5 14726	62.0 13942		
			100000	155.9 35048	126.6 28468	102.9 23123	78.1 17566	63.5 14268	60.1 13508	56.2 12634	53.2 11961		

⁽¹⁾Speeds referenced here may be higher than speed rating for seals. Please refer to the charts on pages C-25 and C-26.

⁽²⁾For speeds greater than thermal reference speed, contact your Timken engineer.

SPHERICAL ROLLER BEARING SOLID-BLOCK HOUSED UNITS

ENGINEERING • BEARING LOAD

LOAD RATINGS – *continued*

TABLE C-6. CL SERIES – ALLOWABLE RADIAL LOAD (kN/LBS.) AT VARIOUS RPM⁽¹⁾

Shaft Diameter	Bearing No.	C	L ₁₀ Life	Speed ⁽²⁾														
				RPM														
mm in.		kN lbs.		50	100	200	500	1000	1200	1500	1800	2100	2400	2700	3000	3200	3500	
35 1 7/16, 1 1/2	22208	104 23400	10000	37.5 8435	30.5 6851	24.8 5565	18.8 4227	15.3 3434	14.5 3251	13.5 3041	12.8 2879	12.2 2749	11.7 2641	11.3 2549	11.0 2470	10.8 2422	10.5 2358	
			30000	27.0 6067	21.9 4928	17.8 4002	13.5 3041	11.0 2470	10.4 2338	9.7 2187	9.2 2070	8.8 1977	8.4 1899	8.2 1833	7.9 1776	7.7 1742	7.5 1696	
			40000	24.8 5565	20.1 4520	16.3 3672	12.4 2789	10.1 2265	9.5 2145	8.9 2006	8.4 1899	8.1 1813	7.7 1742	7.5 1682	7.2 1629	7.1 1629	6.9 1598	6.9 1556
			60000	21.9 4928	17.8 4002	14.5 3251	11.0 2470	8.9 2006	8.4 1899	7.9 1776	7.5 1682	7.1 1606	6.9 1543	6.6 1489	6.4 1443	6.3 1415	6.3 1378	
			100000	18.8 4227	15.3 3434	12.4 2789	9.4 2119	7.7 1721	7.2 1629	6.8 1524	6.4 1443	6.1 1378	5.9 1323	5.7 1278	5.5 1238	5.4 1214	5.3 1182	
40, 45 1 11/16, 1 3/4	22209	109 24500	10000	39.3 8831	31.9 7173	25.9 5827	19.7 4426	16.0 3595	15.1 3404	14.2 3183	13.4 3014	12.8 2878	12.3 2765	11.9 2669	11.5 2586	11.3 2536	11.0 2469	
			30000	28.3 6352	22.9 5159	18.6 4191	14.2 3183	11.5 2586	10.9 2448	10.2 2290	9.6 2168	9.2 2070	8.8 1988	8.5 1919	8.3 1860	8.1 1824	7.9 1776	
			40000	25.9 5827	21.1 4733	17.1 3844	13.0 2920	10.6 2372	10.0 2246	9.3 2100	8.8 1988	8.4 1899	8.1 1824	7.8 1761	7.6 1706	7.4 1673	7.2 1629	
			60000	22.9 5159	18.6 4191	15.1 3404	11.5 2586	9.3 2100	8.8 1988	8.3 1860	7.8 1761	7.5 1681	7.2 1615	6.9 1559	6.7 1511	6.6 1482	6.4 1442	
			100000	19.7 4426	16.0 3595	13.0 2920	9.9 2218	8.0 1802	7.6 1706	7.1 1595	6.7 1511	6.4 1442	6.2 1386	6.0 1338	5.8 1296	5.7 1271	5.5 1237	
50 1 15/16, 2	22210	117 26300	10000	42.2 9480	34.3 7700	27.8 6255	21.1 4751	17.2 3859	16.3 3654	15.2 3417	14.4 3235	13.7 3089	13.2 2968	12.7 2865	12.3 2776	12.1 2723	11.8 2650	
			30000	30.3 6818	24.6 5538	20.0 4498	15.2 3417	12.3 2776	11.7 2628	10.9 2458	10.4 2327	9.9 2222	9.5 2135	9.2 2060	8.9 1996	8.7 1958	8.5 1906	
			40000	27.8 6255	22.6 5080	18.4 4127	13.9 3135	11.3 2546	10.7 2411	10.0 2255	9.5 2135	9.1 2038	8.7 1958	8.4 1890	8.1 1831	8.0 1796	7.8 1749	
			60000	24.6 5538	20.0 4498	16.3 3654	12.3 2776	10.0 2255	9.5 2135	8.9 1996	8.4 1890	8.0 1805	7.7 1734	7.4 1674	7.2 1622	7.1 1590	6.9 1548	
			100000	21.1 4751	17.2 3859	13.9 3135	10.6 2381	8.6 1934	8.1 1831	7.6 1713	7.2 1622	6.9 1548	6.6 1487	6.4 1436	6.2 1391	6.1 1364	5.9 1328	
55 2 3/16, 2 1/4	22211	140 31400	10000	50.3 11319	40.9 9194	33.2 7468	25.2 5673	20.5 4608	19.4 4362	18.1 4080	17.2 3863	16.4 3688	15.8 3543	15.2 3420	14.7 3314	14.5 3250	14.1 3164	
			30000	36.2 8141	29.4 6612	23.9 5371	18.1 4080	14.7 3314	14.0 3138	13.1 2934	12.4 2778	11.8 2653	11.3 2549	10.9 2460	10.6 2383	10.4 2338	10.1 2276	
			40000	33.2 7468	27.0 6066	21.9 4927	16.6 3743	13.5 3040	12.8 2878	12.0 2692	11.3 2549	10.8 2433	10.4 2338	10.0 2257	9.7 2186	9.5 2144	9.3 2088	
			60000	29.4 6612	23.9 5371	19.4 4362	14.7 3314	12.0 2692	11.3 2549	10.6 2383	10.0 2257	9.6 2155	9.2 2070	8.9 1998	8.6 1936	8.4 1899	8.2 1849	
			100000	25.2 5673	20.5 4608	16.6 3743	12.6 2843	10.3 2309	9.7 2186	9.1 2045	8.6 1936	8.2 1849	7.9 1776	7.6 1714	7.4 1661	7.2 1629	7.1 1586	
60, 65 2 7/16, 2 1/2	22213	206 46400	10000	74.4 16726	60.4 13585	49.1 11035	37.3 8383	30.3 6809	28.7 6446	26.8 6029	25.4 5708	24.2 5450	23.3 5236	22.5 5054	21.8 4897	21.4 4803	20.8 4676	
			30000	53.5 12030	43.5 9771	35.3 7937	26.8 6029	21.8 4897	20.6 4636	19.3 4336	18.3 4105	17.4 3920	16.8 3766	16.2 3635	15.7 3522	15.4 3455	15.0 3363	
			40000	49.1 11035	39.9 8963	32.4 7280	24.6 5531	20.0 4492	18.9 4253	17.7 3978	16.8 3766	16.0 3596	15.4 3455	14.8 3335	14.4 3231	14.1 3169	13.7 3085	
			60000	43.5 9771	35.3 7937	28.7 6446	21.8 4897	17.7 3978	16.8 3766	15.7 3522	14.8 3335	14.2 3184	13.6 3059	13.1 2953	12.7 2861	12.5 2806	12.2 2732	
			100000	37.3 8383	30.3 6809	24.6 5531	18.7 4201	15.2 3413	14.4 3231	13.4 3022	12.7 2861	12.2 2732	11.7 2624	11.3 2533	10.9 2454	10.7 2407	10.4 2343	

⁽¹⁾Speeds referenced here may be higher than speed rating for seals. Please refer to the charts on pages C-25 and C-26.

⁽²⁾For speeds greater than thermal reference speed, contact your Timken engineer.

Continued on next page.

SPHERICAL ROLLER BEARING SOLID-BLOCK HOUSED UNITS

ENGINEERING • BEARING LOAD

Continued from previous page.

Shaft Diameter	Bearing No.	C	L ₁₀ Life	Speed ⁽²⁾												
				RPM												
mm in.		kN lbs.		50	100	200	500	1000	1200	1500	1800	2100	2400	2700 ⁽¹⁾	3000 ⁽¹⁾	3200 ⁽¹⁾
70, 75 2 1/16, 2 3/4, 2 15/16, 3	22215	220 49900	10000	80.0 17987	65.0 14610	52.8 11867	40.1 9015	32.6 7322	30.8 6933	28.8 6484	27.3 6139	26.1 5861	25.0 5631	24.2 5436	23.4 5266	23.0 5166
			30000	57.5 12937	46.7 10508	38.0 8535	28.8 6484	23.4 5266	22.2 4986	20.7 4663	19.6 4415	18.8 4216	18.0 4050	17.4 3909	16.8 3788	16.5 3715
			40000	52.8 11867	42.9 9639	34.8 7829	26.5 5948	21.5 4831	20.3 4574	19.0 4278	18.0 4050	17.2 3867	16.5 3715	16.0 3586	15.5 3475	15.2 3408
			60000	46.7 10508	38.0 8535	30.8 6933	23.4 5266	19.0 4278	18.0 4050	16.8 3788	16.0 3586	15.2 3424	14.6 3290	14.1 3175	13.7 3077	13.4 3018
			100000	40.1 9015	32.6 7322	26.5 5948	20.1 4518	16.3 3670	15.5 3475	14.5 3250	13.7 3077	13.1 2938	12.6 2822	12.1 2724	11.7 2639	11.5 2589
				50	100	200	500	1000	1200	1500	1800	2100 ⁽¹⁾	2400 ⁽¹⁾	2700 ⁽¹⁾		
80, 85, 90 3 3/16, 3 1/4, 3 7/16, 3 1/2	22218	355 79700	10000	127.8 28729	103.8 23335	84.3 18954	64.0 14399	52.0 11695	49.3 11073	46.1 10356	43.6 9805	41.6 9362	40.0 8994	38.6 8682		
			30000	91.9 20663	74.7 16783	60.6 13632	46.1 10356	37.4 8412	35.4 7964	33.1 7448	31.4 7052	29.9 6733	28.8 6469	27.8 6244		
			40000	84.3 18954	68.5 15396	55.6 12505	42.3 9500	34.3 7716	32.5 7305	30.4 6832	28.8 6469	27.5 6176	26.4 5934	25.5 5728		
			60000	74.7 16783	60.6 13632	49.3 11073	37.4 8412	30.4 6832	28.8 6469	26.9 6050	25.5 5728	24.3 5469	23.4 5254	22.6 5072		
			100000	64.0 14399	52.0 11695	42.3 9500	32.1 7216	26.1 5862	24.7 5550	23.1 5190	21.9 4914	20.9 4692	20.1 4508	19.4 4351		
				50	100	200	500	1000	1200	1500	1800 ⁽¹⁾	2100 ⁽¹⁾	2400 ⁽¹⁾	2700 ⁽¹⁾		
100 3 15/16, 4	22220	435 97700	10000	156.7 35218	127.2 28606	103.4 23235	78.5 17651	63.8 14337	60.4 13574	56.5 12695	53.5 12019	51.0 11476	49.0 11025	47.3 10642		
			30000	112.7 25329	91.5 20574	74.3 16711	56.5 12695	45.9 10311	43.4 9762	40.6 9130	38.5 8644	36.7 8254	35.3 7930	34.0 7654		
			40000	103.4 23235	84.0 18873	68.2 15329	51.8 11645	42.1 9459	39.8 8955	37.3 8375	35.3 7930	33.7 7571	32.4 7274	31.2 7021		
			60000	91.5 20574	74.3 16711	60.4 13574	45.9 10311	37.3 8375	35.3 7930	33.0 7416	31.2 7021	29.8 6704	28.7 6441	27.7 6217		
			100000	78.5 17651	63.8 14337	51.8 11645	39.3 8846	32.0 7185	30.3 6803	28.3 6362	26.8 6024	25.6 5752	24.6 5526	23.7 5334		
				50	100	200	500	1000	1200	1500 ⁽¹⁾	1800 ⁽¹⁾	2100 ⁽¹⁾	2400 ⁽¹⁾			
110, 115 4 7/16, 4 1/2	22222	555 125000	10000	200.4 45058	162.8 36599	132.2 29727	100.5 22583	81.6 18343	77.3 17367	72.2 16242	68.4 15377	65.3 14683	62.7 14106			
			30000	144.2 32407	117.1 26323	95.1 21381	72.2 16242	58.7 13193	55.6 12490	52.0 11682	49.2 11060	47.0 10560	45.1 10145			
			40000	132.2 29727	107.4 24146	87.2 19613	66.3 14899	53.8 12102	51.0 11458	47.7 10716	45.1 10145	43.1 10145	41.4 9306			
			60000	117.1 26323	95.1 21381	77.3 17367	58.7 13193	47.7 10716	45.1 10145	42.2 9488	40.0 8983	38.2 8577	36.7 8241			
			100000	100.5 22583	81.6 18343	66.3 14899	50.3 11318	40.9 9193	38.7 8704	36.2 8140	34.3 7707	32.7 7359	31.4 7070			
				50	100	200	500	1000	1200 ⁽¹⁾	1500 ⁽¹⁾	1800 ⁽¹⁾	2100 ⁽¹⁾				
125, 130 4 15/16, 5	22226	757 170000	10000	272.6 61279	221.4 49774	179.8 40429	136.6 30712	111.0 24946	105.1 23618	98.3 22089	93.0 20913	88.8 19968				
			30000	196.1 44074	159.2 35799	129.3 29078	98.3 22089	79.8 17942	75.6 16987	70.7 15887	66.9 15041	63.9 14362				
			40000	179.8 40429	146.1 32839	118.6 26673	90.1 20263	73.2 16458	69.3 15582	64.8 14573	61.4 13798	58.6 13174				
			60000	159.2 35799	129.3 29078	105.1 23618	79.8 17942	64.8 14573	61.4 13798	57.4 12904	54.3 12217	51.9 11665				
			100000	136.6 30712	111.0 24946	90.1 20263	68.5 15393	55.6 12503	52.7 11837	49.2 11071	46.6 10482	44.5 10008				
				50	100	200	500	1000	1200 ⁽¹⁾	1500 ⁽¹⁾	1800 ⁽¹⁾	2100 ⁽¹⁾				

⁽¹⁾Speeds referenced here may be higher than speed rating for seals. Please refer to the charts on pages C-25 and C-26.

⁽²⁾For speeds greater than thermal reference speed, contact your Timken engineer.

SPHERICAL ROLLER BEARING SOLID-BLOCK HOUSED UNITS

ENGINEERING • BEARING LOAD

LOAD RATINGS – *continued*

TABLE C-7. EC SERIES – ALLOWABLE RADIAL LOAD (kN/LBS.) AT VARIOUS RPM⁽¹⁾

Shaft Diameter	Bearing No.	C	L ₁₀ Life	Speed ⁽²⁾													
				RPM													
mm in.		kN lbs.		50	100	200	500	1000	1200	1500	1800	2100	2400	2700	3000	3200	3500
35 1 7/16, 1 1/2	22208	104 23400	10000	37.5 8435	30.5 6851	24.8 5565	18.8 4227	15.3 3434	14.5 3251	13.5 3041	12.8 2879	12.2 2749	11.7 2641	11.3 2549	11.0 2470	10.8 2422	10.5 2358
			30000	27.0 6067	21.9 4928	17.8 4002	13.5 3041	11.0 2470	10.4 2338	9.7 2187	9.2 2070	8.8 1977	8.4 1899	8.2 1833	7.9 1776	7.7 1742	7.5 1696
			40000	24.8 5565	20.1 4520	16.3 3672	12.4 2789	10.1 2265	9.5 2145	8.9 2006	8.4 1899	8.1 1813	7.7 1742	7.5 1682	7.2 1629	7.1 1598	6.9 1556
			60000	21.9 4928	17.8 4002	14.5 3251	11.0 2470	8.9 2006	8.4 1899	7.9 1776	7.5 1682	7.1 1606	6.9 1543	6.6 1489	6.4 1443	6.3 1415	6.1 1378
			100000	18.8 4227	15.3 3434	12.4 2789	9.4 2119	7.7 1721	7.2 1629	6.8 1524	6.4 1443	6.1 1378	5.9 1323	5.7 1278	5.5 1238	5.4 1214	5.3 1182
40, 45 1 15/16, 1 3/4	22209	109 24500	10000	39.3 8831	31.9 7173	25.9 5827	19.7 4426	16.0 3595	15.1 3404	14.2 3183	13.4 3014	12.8 2878	12.3 2765	11.9 2669	11.5 2586	11.3 2536	11.0 2469
			30000	28.3 6352	22.9 5159	18.6 4191	14.2 3183	11.5 2586	10.9 2448	10.2 2290	9.6 2168	9.2 2070	8.8 1988	8.5 1919	8.3 1860	8.1 1824	7.9 1776
			40000	25.9 5827	21.1 4733	17.1 3844	13.0 2920	10.6 2372	10.0 2246	9.3 2100	8.8 1988	8.4 1899	8.1 1824	7.8 1761	7.6 1706	7.4 1673	7.2 1629
			60000	22.9 5159	18.6 4191	15.1 3404	11.5 2586	9.3 2100	8.8 1988	8.3 1860	7.8 1761	7.5 1681	7.2 1615	6.9 1559	6.7 1511	6.6 1482	6.4 1442
			100000	19.7 4426	16.0 3595	13.0 2920	9.9 2218	8.0 1802	7.6 1706	7.1 1595	6.7 1511	6.4 1442	6.2 1386	6.0 1338	5.8 1296	5.7 1271	5.5 1237
50 1 15/16, 2	22210	117 26300	10000	42.2 9480	34.3 7700	27.8 6255	21.1 4751	17.2 3859	16.3 3654	15.2 3417	14.4 3235	13.7 3089	13.2 2968	12.7 2865	12.3 2776	12.1 2723	11.8 2650
			30000	30.3 6818	24.6 5538	20.0 4498	15.2 3417	12.3 2776	11.7 2628	10.9 2458	10.4 2327	9.9 2222	9.5 2135	9.2 2060	8.9 1996	8.7 1958	8.5 1906
			40000	27.8 6255	22.6 5080	18.4 4127	13.9 3135	11.3 2546	10.7 2411	10.0 2255	9.5 2135	9.1 2038	8.7 1958	8.4 1890	8.1 1831	8.0 1796	7.8 1749
			60000	24.6 5538	20.0 4498	16.3 3654	12.3 2776	10.0 2255	9.5 2135	8.9 1996	8.4 1890	8.0 1805	7.7 1734	7.4 1674	7.2 1622	7.1 1590	6.9 1548
			100000	21.1 4751	17.2 3859	13.9 3135	10.6 2381	8.6 1934	8.1 1831	7.6 1713	7.2 1622	6.9 1548	6.6 1487	6.4 1436	6.2 1391	6.1 1364	5.9 1328
55 2 3/16, 2 1/4	22211	140 31400	10000	50.3 11319	40.9 9194	33.2 7468	25.2 5673	20.5 4608	19.4 4362	18.1 4080	17.2 3863	16.4 3688	15.8 3543	15.2 3420	14.7 3314	14.5 3250	14.1 3164
			30000	36.2 8141	29.4 6612	23.9 5371	18.1 4080	14.7 3314	14.0 3138	13.1 2934	12.4 2778	11.8 2653	11.3 2549	10.9 2460	10.6 2383	10.4 2338	10.1 2276
			40000	33.2 7468	27.0 6066	21.9 4927	16.6 3743	13.5 3040	12.8 2878	12.0 2692	11.3 2549	10.8 2433	10.4 2338	10.0 2257	9.7 2186	9.5 2144	9.3 2088
			60000	29.4 6612	23.9 5371	19.4 4362	14.7 3314	12.0 2692	11.3 2549	10.6 2383	10.0 2257	9.6 2155	9.2 2070	8.9 1998	8.6 1936	8.4 1899	8.2 1849
			100000	25.2 5673	20.5 4608	16.6 3743	12.6 2843	10.3 2309	9.7 2186	9.1 2045	8.6 1936	8.2 1849	7.9 1776	7.6 1714	7.4 1661	7.2 1629	7.1 1586
60, 65 2 7/16, 2 1/2	22213	206 46400	10000	74.4 16726	60.4 13585	49.1 11035	37.3 8383	30.3 6809	28.7 6446	26.8 6029	25.4 5708	24.2 5450	23.3 5236	22.5 5054	21.8 4897	21.4 4803	20.8 4676
			30000	53.5 12030	43.5 9771	35.3 7937	26.8 6029	21.8 4897	20.6 4636	19.3 4336	18.3 4105	17.4 3920	16.8 3766	16.2 3635	15.7 3522	15.4 3455	15.0 3363
			40000	49.1 11035	39.9 8963	32.4 7280	24.6 5531	20.0 4492	18.9 4253	17.7 3978	16.8 3766	16.0 3596	15.4 3455	14.8 3335	14.4 3231	14.1 3169	13.7 3085
			60000	43.5 9771	35.3 7937	28.7 6446	21.8 4897	17.7 3978	16.8 3766	15.7 3522	14.8 3335	14.2 3184	13.6 3059	13.1 2953	12.7 2861	12.5 2806	12.2 2732
			100000	37.3 8383	30.3 6809	24.6 5531	18.7 4201	15.2 3413	14.4 3231	13.4 3022	12.7 2861	12.2 2732	11.7 2624	11.3 2533	10.9 2454	10.7 2407	10.4 2343

⁽¹⁾Speeds referenced here may be higher than speed rating for seals. Please refer to the charts on pages C-25 and C-26.

⁽²⁾For speeds greater than thermal reference speed, contact your Timken engineer.

Continued on next page.

SPHERICAL ROLLER BEARING SOLID-BLOCK HOUSED UNITS

ENGINEERING • BEARING LOAD

Continued from previous page.

Shaft Diameter	Bearing No.	C	L ₁₀ Life	Speed ⁽²⁾														
				RPM														
mm in.		kN lbs.		50	100	200	500	1000	1200	1500	1800	2100	2400	2700 ⁽¹⁾	3000 ⁽¹⁾	3200 ⁽¹⁾		
70, 75 2 1/16, 2 3/4, 2 15/16, 3	22215	222 49900	10000	80.0 17987	65.0 14610	52.8 11867	40.1 9015	32.6 7322	30.8 6933	28.8 6484	27.3 6139	26.1 5861	25.0 5631	24.2 5436	23.4 5266	23.0 5166		
			30000	57.5 12937	46.7 10508	38.0 8535	28.8 6484	23.4 5266	22.2 4986	20.7 4663	19.6 4415	18.8 4216	18.0 4050	17.4 3909	16.8 3788	16.5 3715		
			40000	52.8 11867	42.9 9639	34.8 7829	26.5 5948	21.5 4831	20.3 4574	19.0 4278	18.0 4050	17.2 3867	16.5 3715	16.0 3586	15.5 3475	15.2 3408		
			60000	46.7 10508	38.0 8535	30.8 6933	23.4 5266	19.0 4278	18.0 4050	16.8 3788	16.0 3586	15.2 3424	14.6 3290	14.1 3175	13.7 3077	13.4 3018		
			100000	40.1 9015	32.6 7322	26.5 5948	20.1 4518	16.3 3670	15.5 3475	14.5 3250	13.7 3077	13.1 2938	12.6 2822	12.1 2724	11.7 2639	11.5 2589		
				50	100	200	500	1000	1200	1500	1800	2100 ⁽¹⁾	2400 ⁽¹⁾	2700 ⁽¹⁾				
80, 85, 90 3 3/16, 3 1/4, 3 7/16, 3 1/2	22218	355 79700	10000	127.8 28729	103.8 23335	84.3 18954	64.0 14399	52.0 11695	49.3 11073	46.1 10356	43.6 9805	41.6 9362	40.0 8994	38.6 8682				
			30000	91.9 20663	74.7 16783	60.6 13632	46.1 10356	37.4 8412	35.4 7964	33.1 7448	31.4 7052	29.9 6733	28.8 6469	27.8 6244				
			40000	84.3 18954	68.5 15396	55.6 12505	42.3 9500	34.3 7716	32.5 7305	30.4 6832	28.8 6469	27.5 6176	26.4 5934	25.5 5728				
			60000	74.7 16783	60.6 13632	49.3 11073	37.4 8412	30.4 6832	28.8 6469	26.9 6050	25.5 5728	24.3 5469	23.4 5254	22.6 5072				
			100000	64.0 14399	52.0 11695	42.3 9500	32.1 7216	26.1 5862	24.7 5550	23.1 5190	21.9 4914	20.9 4692	20.1 4508	19.4 4351				
				50	100	200	500	1000	1200	1500	1800 ⁽¹⁾	2100 ⁽¹⁾	2400 ⁽¹⁾	2700 ⁽¹⁾				
100 3 11/16, 3 3/4, 3 15/16, 4	22220	435 97700	10000	156.7 35218	127.2 28606	103.4 23235	78.5 17651	63.8 14337	60.4 13574	56.5 12695	53.5 12019	51.0 11476	49.0 11025	47.3 10642				
			30000	112.7 25329	91.5 20574	74.3 16711	56.5 12695	45.9 10311	43.4 9762	40.6 9130	38.5 8644	36.7 8254	35.3 7930	34.0 7654				
			40000	103.4 23235	84.0 18873	68.2 15329	51.8 11645	42.1 9459	39.8 8955	37.3 8375	35.3 7930	33.7 7571	32.4 7274	31.2 7021				
			60000	91.5 20574	74.3 16711	60.4 13574	45.9 10311	37.3 8375	35.3 7930	33.0 7416	31.2 7021	29.8 6704	28.7 6441	27.7 6217				
			100000	78.5 17651	63.8 14337	51.8 11645	39.3 8846	32.0 7185	30.3 6803	28.3 6362	26.8 6024	25.6 5752	24.6 5526	23.7 5334				
				50	100	200	500	1000	1200	1500 ⁽¹⁾	1800 ⁽¹⁾	2100 ⁽¹⁾	2400 ⁽¹⁾					
110, 115 4 7/16, 4 1/2	22222	555 125000	10000	200.4 45058	162.8 36599	132.2 29727	100.5 22583	81.6 18343	77.3 17367	72.2 16242	68.4 15377	65.3 14683	62.7 14106					
			30000	144.2 32407	117.1 26323	95.1 21381	72.2 16242	58.7 13193	55.6 12490	52.0 11682	49.2 11060	47.0 10560	45.1 10145					
			40000	132.2 29727	107.4 24146	87.2 19613	66.3 14899	53.8 12102	51.0 11458	47.7 10716	45.1 10145	43.1 9687	41.4 9306					
			60000	117.1 26323	95.1 21381	77.3 17367	58.7 13193	47.7 10716	45.1 10145	42.2 9488	40.0 8983	38.2 8577	36.7 8241					
			100000	100.5 22583	81.6 18343	66.3 14899	50.3 11318	40.9 9193	38.7 8704	36.2 8140	34.3 7707	32.7 7359	31.4 7070					
				50	100	200	500	1000	1200 ⁽¹⁾	1500 ⁽¹⁾	1800 ⁽¹⁾	2100 ⁽¹⁾						
125, 130 4 15/16, 5	22226	757 170000	10000	272.6 61279	221.4 49774	179.8 40429	136.6 30712	111.0 24946	105.1 23618	98.3 22089	93.0 20913	88.8 19968						
			30000	196.1 44074	159.2 35799	129.3 29078	98.3 22089	79.8 17942	75.6 16987	70.7 15887	66.9 15041	63.9 14362						
			40000	179.8 40429	146.1 32839	118.6 26673	90.1 20263	73.2 16458	69.3 15582	64.8 14573	61.4 13798	58.6 13174						
			60000	159.2 35799	129.3 29078	105.1 23618	79.8 17942	64.8 14573	61.4 13798	57.4 12904	54.3 12217	51.9 11665						
			100000	136.6 30712	111.0 24946	90.1 20263	68.5 15393	55.6 12503	52.7 11837	49.2 11071	46.6 10482	44.5 10008						

⁽¹⁾Speeds referenced here may be higher than speed rating for seals. Please refer to the charts on pages C-25 and C-26.

⁽²⁾For speeds greater than thermal reference speed, contact your Timken engineer.

Continued on next page.

LOAD RATINGS – *continued*

TABLE C-7. EC SERIES – ALLOWABLE RADIAL LOAD (kN/LBS.) AT VARIOUS RPM⁽¹⁾ – *continued*

Shaft Diameter	Bearing No.	C	L ₁₀ Life	Speed ⁽²⁾					
				RPM					
mm in.		kN lbs.		50	100	200	500	1000 ⁽¹⁾	1200 ⁽¹⁾
140, 150 5 7/16, 5 1/2, 5 15/16, 6	23230	1270 286000	10000	458.6 103094	372.5 83738	302.6 68016	229.8 51669	186.7 41968	176.8 39735
			30000	329.8 74147	267.9 60226	217.6 48919	165.3 37162	134.3 30185	127.1 28578
			40000	302.6 68016	245.8 55247	199.6 44874	151.6 34089	123.2 27689	116.6 26215
			60000	267.9 60226	217.6 48919	176.8 39735	134.3 30185	109.1 24518	103.3 23213
			100000	229.8 51669	186.7 41968	151.6 34089	115.2 25896	93.6 21034	88.6 19914
170, 180 6 7/16, 6 1/2, 6 15/16, 7	23234	1660 373000	10000	598.1 134454	485.8 109211	394.6 88707	299.8 67387	243.5 54735	
			30000	430.2 96703	349.4 78547	283.8 63800	215.6 48466	175.1 39367	
			40000	394.6 88707	320.5 72052	260.3 58525	197.8 44459	160.6 36112	
			60000	349.4 78547	283.8 63800	230.5 51822	175.1 39367	142.2 31976	
			100000	299.8 67387	243.5 54735	197.8 44459	150.2 33773	122.0 27433	

⁽¹⁾Speeds referenced here may be higher than speed rating for seals. Please refer to the charts on pages C-25 and C-26.

⁽²⁾For speeds greater than thermal reference speed, contact your Timken engineer.

TABLE C-8. TA/DV SERIES – ALLOWABLE RADIAL LOAD (kN/LBS.) AT VARIOUS RPM⁽¹⁾

Shaft Diameter	Bearing No.	C	L ₁₀ Life	Speed ⁽²⁾														
				RPM														
mm in.		kN lbs.		50	100	200	500	1000	1200	1500	1800	2100	2400	2700	3000	3200	3500	
40 1 7/16, 1 1/2	22209	109 24500	10000	39.3 8831	31.9 7173	25.9 5827	19.7 4426	16.0 3595	15.1 3404	14.2 3183	13.4 3014	12.8 2878	12.3 2765	11.9 2669	11.5 2586	11.3 2536	11.0 2469	
			30000	28.3 6352	22.9 5159	18.6 4191	14.2 3183	11.5 2586	10.9 2448	10.2 2290	9.6 2168	9.2 2070	8.8 1988	8.5 1919	8.3 1860	8.1 1824	7.9 1776	
			40000	25.9 5827	21.1 4733	17.1 3844	13.0 2920	10.6 2372	10.0 2246	9.3 2100	8.8 1988	8.4 1899	8.1 1824	7.8 1761	7.7 1761	7.6 1706	7.4 1673	7.2 1629
			60000	22.9 5159	18.6 4191	15.1 3404	11.5 2586	9.3 2100	8.8 1988	8.3 1860	7.8 1761	7.5 1681	7.2 1615	6.9 1559	6.7 1511	6.6 1482	6.4 1442	
			100000	19.7 4426	16.0 3595	13.0 2920	9.9 2218	8.0 1802	7.6 1706	7.1 1595	6.7 1511	6.4 1442	6.2 1386	6.0 1338	5.8 1296	5.7 1271	5.5 1237	
				50	100	200	500	1000	1200	1500	1800	2100	2400	2700	3000	3200	3500	
45 1 11/16, 1 3/4	22210	117 26300	10000	42.2 9480	34.3 7700	27.8 6255	21.1 4751	17.2 3859	16.3 3654	15.2 3417	14.4 3235	13.7 3089	13.2 2968	12.7 2865	12.3 2776	12.1 2723	11.8 2650	
			30000	30.3 6818	24.6 5538	20.0 4498	15.2 3417	12.3 2776	11.7 2628	10.9 2458	10.4 2327	9.9 2222	9.5 2135	9.2 2060	8.9 1996	8.7 1958	8.5 1906	
			40000	27.8 6255	22.6 5080	18.4 4127	13.9 3135	11.3 2546	10.7 2411	10.0 2255	9.5 2135	9.1 2038	8.7 1958	8.4 1890	8.1 1831	8.0 1796	7.8 1749	
			60000	24.6 5538	20.0 4498	16.3 3654	12.3 2776	10.0 2255	9.5 2135	8.9 1996	8.4 1890	8.0 1805	7.7 1734	7.4 1674	7.2 1622	7.1 1590	6.9 1548	
			100000	21.1 4751	17.2 3859	13.9 3135	10.6 2381	8.6 1934	8.1 1831	7.6 1713	7.2 1622	6.9 1548	6.6 1487	6.4 1436	6.2 1391	6.1 1364	5.9 1328	
				50	100	200	500	1000	1200	1500	1800	2100	2400	2700	3000	3200	3500 ⁽¹⁾	
50 1 15/16, 2	22211	140 31400	10000	50.3 11319	40.9 9194	33.2 7468	25.2 5673	20.5 4608	19.4 4362	18.1 4080	17.2 3863	16.4 3688	15.8 3543	15.2 3420	14.7 3314	14.5 3250	14.1 3164	
			30000	36.2 8141	29.4 6612	23.9 5371	18.1 4080	14.7 3314	14.0 3138	13.1 2934	12.4 2778	11.8 2653	11.3 2549	10.9 2460	10.6 2383	10.4 2338	10.1 2276	
			40000	33.2 7468	27.0 6066	21.9 4927	16.6 3743	13.5 3040	12.8 2878	12.0 2692	11.3 2549	10.8 2433	10.4 2338	10.0 2257	9.7 2186	9.5 2144	9.3 2088	
			60000	29.4 6612	23.9 5371	19.4 4362	14.7 3314	12.0 2692	11.3 2549	10.6 2383	10.0 2257	9.6 2155	9.2 2070	8.9 1998	8.6 1936	8.4 1899	8.2 1849	
			100000	25.2 5673	20.5 4608	16.6 3743	12.6 2843	10.3 2309	9.7 2186	9.1 2045	8.6 1936	8.2 1849	7.9 1776	7.6 1714	7.4 1661	7.2 1629	7.1 1586	
				50	100	200	500	1000	1200	1500	1800	2100	2400	2700	3000	3200 ⁽¹⁾	3500 ⁽¹⁾	
55 –	22212	169 38100	10000	61.1 13734	49.6 11155	40.3 9061	30.6 6883	24.9 5591	23.5 5293	22.0 4951	20.8 4687	19.9 4475	19.1 4300	18.5 4150	17.9 4021	17.5 3944	17.1 3839	
			30000	43.9 9878	35.7 8023	29.0 6517	22.0 4951	17.9 4021	16.9 3807	15.8 3561	15.0 3371	14.3 3219	13.8 3092	13.3 2985	12.9 2892	12.6 2837	12.3 2761	
			40000	40.3 9061	32.7 7360	26.6 5978	20.2 4541	16.4 3689	15.5 3492	14.5 3266	13.8 3092	13.1 2953	12.6 2837	12.2 2738	11.8 2653	11.6 2602	11.3 2533	
			60000	35.7 8023	29.0 6517	23.5 5293	17.9 4021	14.5 3266	13.8 3092	12.9 2892	12.2 2738	11.6 2614	11.2 2512	10.8 2425	10.4 2349	10.2 2304	10.0 2243	
			100000	30.6 6883	24.9 5591	20.2 4541	15.3 3450	12.5 2802	11.8 2653	11.0 2481	10.4 2349	10.0 2243	9.6 2155	9.3 2080	9.0 2015	8.8 1977	8.6 1924	
				50	100	200	500	1000	1200	1500	1800	2100	2400	2700	3000 ⁽¹⁾	3200 ⁽¹⁾	3500 ⁽¹⁾	
60 2 3/16, 2 1/4	22213	206 46400	10000	74.4 16726	60.4 13585	49.1 11035	37.3 8383	30.3 6809	28.7 6446	26.8 6029	25.4 5708	24.2 5450	23.3 5236	22.5 5054	21.8 4897	21.4 4803	20.8 4676	
			30000	53.5 12030	43.5 9771	35.3 7937	26.8 6029	21.8 4897	20.6 4636	19.3 4336	18.3 4105	17.4 3920	16.8 3766	16.2 3635	15.7 3522	15.4 3455	15.0 3363	
			40000	49.1 11035	39.9 8963	32.4 7280	24.6 5531	20.0 4492	18.9 4253	17.7 3978	16.8 3766	16.0 3596	15.4 3455	14.8 3335	14.4 3231	14.1 3169	13.7 3085	
			60000	43.5 9771	35.3 7937	28.7 6446	21.8 4897	17.7 3978	16.8 3766	15.7 3522	14.8 3335	14.2 3184	13.6 3059	13.1 2953	12.7 2861	12.5 2806	12.2 2732	
			100000	37.3 8383	30.3 6809	24.6 5531	18.7 4201	15.2 3413	14.4 3231	13.4 3022	12.7 2861	12.2 2732	11.7 2624	11.3 2533	10.9 2454	10.7 2407	10.4 2343	
				50	100	200	500	1000	1200	1500	1800	2100	2400	2700	3000 ⁽¹⁾	3200 ⁽¹⁾	3500 ⁽¹⁾	

⁽¹⁾Speeds referenced here may be higher than speed rating for seals. Please refer to the charts on pages C-25 and C-26.

⁽²⁾For speeds greater than thermal reference speed, contact your Timken engineer.

Continued on next page.

SPHERICAL ROLLER BEARING SOLID-BLOCK HOUSED UNITS

ENGINEERING • BEARING LOAD

LOAD RATINGS – continued

TABLE C-8. TA/DV SERIES – ALLOWABLE RADIAL LOAD (kN/LBS.) AT VARIOUS RPM⁽¹⁾ – continued

Shaft Diameter	Bearing No.	C	L ₁₀ Life	Speed ⁽²⁾												
				RPM												
mm in.		kN lbs.		50	100	200	500	1000	1200	1500	1800	2100	2400	2700 ⁽¹⁾	3000 ⁽¹⁾	3200 ⁽¹⁾
65 2 7/16, 2 1/2	22215	222 49900	10000	80.0 17987	65.0 14610	52.8 11867	40.1 9015	32.6 7322	30.8 6933	28.8 6484	27.3 6139	26.1 5861	25.0 5631	24.2 5436	23.4 5266	23.0 5166
			30000	57.5 12937	46.7 10508	38.0 8535	28.8 6484	23.4 5266	22.2 4986	20.7 4663	19.6 4415	18.8 4216	18.0 4050	17.4 3909	16.8 3788	16.5 3715
			40000	52.8 11867	42.9 9639	34.8 7829	26.5 5948	21.5 4831	20.3 4574	19.0 4278	18.0 4050	17.2 3867	16.5 3715	16.0 3586	15.5 3475	15.2 3408
			60000	46.7 10508	38.0 8535	30.8 6933	23.4 5266	19.0 4278	18.0 4050	16.8 3788	16.0 3586	15.2 3424	14.6 3290	14.1 3175	13.7 3077	13.4 3018
			100000	40.1 9015	32.6 7322	26.5 5948	20.1 4518	16.3 3670	15.5 3475	14.5 3250	13.7 3077	13.1 2938	12.6 2822	12.1 2724	11.7 2639	11.5 2589
						50	100	200	500	1000	1200	1500	1800	2100	2400 ⁽¹⁾	2700 ⁽¹⁾
70 2 11/16, 2 3/4	22216	254 57200	10000	91.7 20619	74.5 16748	60.5 13603	46.0 10334	37.3 8394	35.4 7947	33.1 7432	31.3 7037	29.9 6719	28.7 6455	27.7 6231	26.9 6037	
			30000	66.0 14829	53.6 12045	43.5 9784	33.1 7432	26.9 6037	25.4 5716	23.8 5346	22.5 5061	21.5 4832	20.7 4643	19.9 4481	19.3 4342	
			40000	60.5 13603	49.1 11049	39.9 8975	30.3 6818	24.6 5538	23.3 5243	21.8 4904	20.7 4643	19.7 4433	18.9 4259	18.3 4111	17.7 3983	
			60000	53.6 12045	43.5 9784	35.4 7947	26.9 6037	21.8 4904	20.7 4643	19.3 4342	18.3 4111	17.5 3925	16.8 3771	16.2 3640	15.7 3527	
			100000	46.0 10334	37.3 8394	30.3 6818	23.0 5179	18.7 4207	17.7 3983	16.6 3725	15.7 3527	15.0 3367	14.4 3235	13.9 3123	13.5 3026	
						50	100	200	500	1000	1200	1500	1800	2100 ⁽¹⁾	2400 ⁽¹⁾	2700 ⁽¹⁾
75 2 15/16, 3	22217	297 66900	10000	107.3 24115	87.1 19588	70.8 15910	53.8 12086	43.7 9817	41.3 9295	38.7 8693	36.6 8230	35.0 7858	33.6 7550	32.4 7287		
			30000	77.1 17344	62.7 14088	50.9 11443	38.7 8693	31.4 7061	29.7 6685	27.8 6252	26.3 5919	25.1 5652	24.2 5430	23.3 5241		
			40000	70.8 15910	57.5 12923	46.7 10497	35.5 7974	28.8 6477	27.3 6132	25.5 5735	24.2 5430	23.1 5184	22.2 4981	21.4 4808		
			60000	62.7 14088	50.9 11443	41.3 9295	31.4 7061	25.5 5735	24.2 5430	22.6 5078	21.4 4808	20.4 4591	19.6 4410	18.9 4257		
			100000	53.8 12086	43.7 9817	35.5 7974	26.9 6057	21.9 4920	20.7 4658	19.4 4357	18.3 4125	17.5 3938	16.8 3784	16.2 3652		
						50	100	200	500	1000	1200	1500	1800	2100 ⁽¹⁾	2400 ⁽¹⁾	2700 ⁽¹⁾
80 3 3/16, 3 1/4	22218	355 79700	10000	127.8 28729	103.8 23335	84.3 18954	64.0 14399	52.0 11695	49.3 11073	46.1 10356	43.6 9805	41.6 9362	40.0 8994	38.6 8682		
			30000	91.9 20663	74.7 16783	60.6 13632	46.1 10356	37.4 8412	35.4 7964	33.1 7448	31.4 7052	29.9 6733	28.8 6469	27.8 6244		
			40000	84.3 18954	68.5 15396	55.6 12505	42.3 9500	34.3 7716	32.5 7305	30.4 6832	28.8 6469	27.5 6176	26.4 5934	25.5 5728		
			60000	74.7 16783	60.6 13632	49.3 11073	37.4 8412	30.4 6832	28.8 6469	26.9 6050	25.5 5728	24.3 5469	23.4 5254	22.6 5072		
			100000	64.0 14399	52.0 11695	42.3 9500	32.1 7216	26.1 5862	24.7 5550	23.1 5190	21.9 4914	20.9 4692	20.1 4508	19.4 4351		
						50	100	200	500	1000	1200	1500	1800	2100 ⁽¹⁾	2400 ⁽¹⁾	2700 ⁽¹⁾
85 –	22219	385 86600	10000	138.9 31216	112.8 25356	91.6 20595	69.6 15645	56.5 12708	53.5 12032	50.1 11252	47.4 10654	45.2 10172	43.5 9773	42.0 9433		
			30000	99.9 22452	81.1 18236	65.9 14813	50.1 11252	40.7 9140	38.5 8653	36.0 8093	34.1 7662	32.5 7316	31.3 7029	30.2 6785		
			40000	91.6 20595	74.4 16729	60.4 13588	45.9 10322	37.3 8384	35.3 7938	33.0 7424	31.3 7029	29.9 6711	28.7 6448	27.7 6224		
			60000	81.1 18236	65.9 14813	53.5 12032	40.7 9140	33.0 7424	31.3 7029	29.2 6574	27.7 6224	26.4 5942	25.4 5709	24.5 5511		
			100000	69.6 15645	56.5 12708	45.9 10322	34.9 7841	28.3 6369	26.8 6030	25.1 5640	23.7 5339	22.7 5098	21.8 4898	21.0 4728		
						50	100	200	500	1000	1200	1500	1800	2100 ⁽¹⁾	2400 ⁽¹⁾	2700 ⁽¹⁾

⁽¹⁾Speeds referenced here may be higher than speed rating for seals. Please refer to the charts on pages C-25 and C-26.

⁽²⁾For speeds greater than thermal reference speed, contact your Timken engineer.

Continued on next page.

SPHERICAL ROLLER BEARING SOLID-BLOCK HOUSED UNITS

ENGINEERING • BEARING LOAD

Continued from previous page.

Shaft Diameter	Bearing No.	C	L ₁₀ Life	Speed ⁽²⁾											
				RPM											
mm in.		kN lbs.		50	100	200	500	1000	1200	1500	1800 ⁽¹⁾	2100 ⁽¹⁾	2400 ⁽¹⁾	2700 ⁽¹⁾	
90 3 7/16, 3 1/2	22220	435 97700	10000	156.7 35218	127.2 28606	103.4 23235	78.5 17651	63.8 14337	60.4 13574	56.5 12695	53.5 12019	51.0 11476	49.0 11025	47.3 10642	
			30000	112.7 25329	91.5 20574	74.3 16711	56.5 12695	45.9 10311	43.4 9762	40.6 9130	38.5 8644	36.7 8254	35.3 7930	34.0 7654	
			40000	103.4 23235	84.0 18873	68.2 15329	51.8 11645	42.1 9459	39.8 8955	37.3 8375	35.3 7930	33.7 7930	33.7 7571	32.4 7274	31.2 7021
			60000	91.5 20574	74.3 16711	60.4 13574	45.9 10311	37.3 8375	35.3 7930	33.0 7416	31.2 7021	29.8 6704	28.7 6441	27.7 6217	
			100000	78.5 17651	63.8 14337	51.8 11645	39.3 8846	32.0 7185	30.3 6803	28.3 6362	26.8 6024	25.6 5752	24.6 5526	23.7 5334	
							50	100	200	500	1000	1200	1500 ⁽¹⁾	1800 ⁽¹⁾	2100 ⁽¹⁾
100 3 15/16, 4	22222	555 125000	10000	200.4 45058	162.8 36599	132.2 29727	100.5 22583	81.6 18343	77.3 17367	72.2 16242	68.4 15377	65.3 14683	62.7 14106		
			30000	144.2 32407	117.1 26323	95.1 21381	72.2 16242	58.7 13193	55.6 12490	52.0 11682	49.2 11060	47.0 10560	45.1 10145		
			40000	132.2 29727	107.4 24146	87.2 19613	66.3 14899	53.8 12102	51.0 11458	47.7 10716	45.1 10145	43.1 9687	41.4 9306		
			60000	117.1 26323	95.1 21381	77.3 17367	58.7 13193	47.7 10716	45.1 10145	42.2 9488	40.0 8983	38.2 8577	36.7 8241		
			100000	100.5 22583	81.6 18343	66.3 14899	50.3 11318	40.9 9193	38.7 8704	36.2 8140	34.3 7707	32.7 7359	31.4 7070		
							50	100	200	500	1000	1200	1500 ⁽¹⁾	1800 ⁽¹⁾	2100 ⁽¹⁾
110 4 3/16, 4 1/4	22224	647 145000	10000	232.5 52268	188.8 42455	153.4 34484	116.5 26196	94.6 21278	89.6 20145	83.8 18841	79.3 17838	75.8 17032	72.8 16363		
			30000	167.2 37592	135.8 30534	110.3 24802	83.8 18841	68.1 15303	64.5 14489	60.3 13551	57.1 12829	54.5 12250	52.4 11769		
			40000	153.4 34484	124.6 28010	101.2 22751	76.9 17283	62.4 14038	59.1 13291	55.3 12430	52.4 11769	50.0 11237	48.0 10796		
			60000	135.8 30534	110.3 24802	89.6 20145	68.1 15303	55.3 12430	52.4 11769	49.0 11007	46.4 10421	44.3 9950	42.5 9559		
			100000	116.5 26196	94.6 21278	76.9 17283	58.4 13129	47.4 10664	44.9 10097	42.0 9443	39.8 8940	38.0 8536	36.5 8201		
							50	100	200	500	1000	1200 ⁽¹⁾	1500 ⁽¹⁾	1800 ⁽¹⁾	2100 ⁽¹⁾
115 4 7/16, 4 1/2	22226	757 170000	10000	272.6 61279	221.4 49774	179.8 40429	136.6 30712	111.0 24946	105.1 23618	98.3 22089	93.0 20913	88.8 19968			
			30000	196.1 44074	159.2 35799	129.3 29078	98.3 22089	79.8 17942	75.6 16987	70.7 15887	66.9 15041	63.9 14362			
			40000	179.8 40429	146.1 32839	118.6 26673	90.1 20263	73.2 16458	69.3 15582	64.8 14573	61.4 13798	58.6 13174			
			60000	159.2 35799	129.3 29078	105.1 23618	79.8 17942	64.8 14573	61.4 13798	57.4 12904	54.3 12217	51.9 11665			
			100000	136.6 30712	111.0 24946	90.1 20263	68.5 15393	55.6 12503	52.7 11837	49.2 11071	46.6 10482	44.5 10008			
							50	100	200	500	1000 ⁽¹⁾	1200 ⁽¹⁾	1500 ⁽¹⁾	1800 ⁽¹⁾	
125 4 15/16, 5	22228	863 194000	10000	311.1 69931	252.7 56801	205.2 46137	155.9 35048	126.6 28468	119.9 26953	112.1 25208	106.2 23866				
			30000	223.7 50296	181.7 40853	147.6 33183	112.1 25208	91.1 20475	86.2 19385	80.6 18130	76.4 17165				
			40000	205.2 46137	166.7 37475	135.4 30439	102.9 23123	83.5 18782	79.1 17782	74.0 16631	70.0 15746				
			60000	181.7 40853	147.6 33183	119.9 26953	91.1 20475	74.0 16631	70.0 15746	65.5 14726	62.0 13942				
			100000	155.9 35048	126.6 28468	102.9 23123	78.1 17566	63.5 14268	60.1 13508	56.2 12634	53.2 11961				
							50	100	200	500	1000 ⁽¹⁾	1200 ⁽¹⁾	1500 ⁽¹⁾	1800 ⁽¹⁾	

⁽¹⁾Speeds referenced here may be higher than speed rating for seals. Please refer to the charts on pages C-25 and C-26.

⁽²⁾For speeds greater than thermal reference speed, contact your Timken engineer.

HOUSING LOADS

Because solid-block housed unit bearings are made of cast steel, they are built to last with high allowable load in multiple orientations.

Refer to tables below for allowable housing loads.

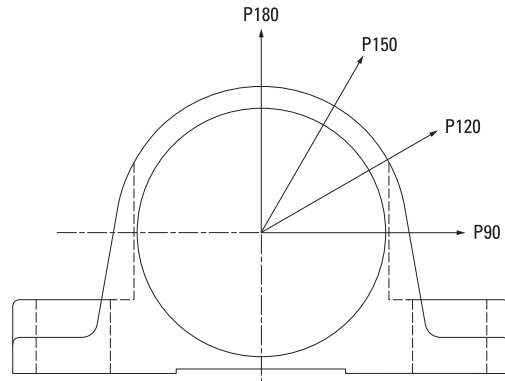

Fig. C-15. Allowable housing loads.

TABLE C-9. HOUSING CAPACITY CHART (222XX SERIES)

Bearing No.	Static Capacity	Fs Ratio 1:5	Timken Factor 180	Housing Capacity 180	Timken Factor 150	Housing Capacity 150	Timken Factor 120	Housing Capacity 120	Timken Factor 90	Housing Capacity 90
	kN lbs.			kN lbs.		kN lbs.		kN lbs.		kN lbs.
22208	99.7 22400	0.20	1	20 4480	0.86	17 3850	1	20 4480	1.73	34 7750
22209	108 24200	0.20	1	22 4840	0.86	18 4160	1	22 4840	1.73	37 8370
22210	118 26600	0.20	1	24 5320	0.86	20 4570	1	24 5320	1.73	41 9200
22211	142 31900	0.20	1	28 6380	0.86	24 5490	1	28 6380	1.73	49 11040
22212	174 39000	0.20	1	35 7800	0.86	30 6710	1	35 7800	1.73	60 13490
22213	216 48600	0.20	1	43 9720	0.86	37 8360	1	43 9720	1.73	75 16820
22214	231 52000	0.20	1	46 10400	0.86	40 8940	1	46 10400	1.73	80 17990
22215	240 54100	0.20	1	48 10820	0.86	41 9310	1	48 10820	1.73	83 18720
22216	278 62500	0.20	1	56 12500	0.86	48 10750	1	56 12500	1.73	96 21630
22217	320 71900	0.20	1	64 14380	0.86	55 12370	1	64 14380	1.73	111 24880
22218	388 87200	0.20	1	78 17440	0.86	67 15000	1	78 17440	1.73	134 30170
22219	441 99000	0.20	1	88 19800	0.86	76 17030	1	88 19800	1.73	152 34250
22220	502 113000	0.20	1	100 22600	0.86	86 19440	1	100 22600	1.73	174 39100
22222	653 147000	0.20	1	131 29400	0.86	112 25290	1	131 29400	1.73	226 50860
22224	772 174000	0.20	1	155 34800	0.86	133 29930	1	155 34800	1.73	268 60200
22226	945 212000	0.20	1	188 42400	0.86	162 36460	1	188 42400	1.73	326 73350
22228	1060 237000	0.20	1	211 47400	0.86	181 40760	1	211 47400	1.73	364 82000

TABLE C-10. HOUSING CAPACITY CHART (232XX SERIES)

Bearing	Static Capacity	Fs Ratio 1:5	Timken Factor 180	Housing Capacity 180	Timken Factor 150	Housing Capacity 150	Timken Factor 120	Housing Capacity 120	Timken Factor 90	Housing Capacity 90
	kN lbs.			kN lbs.		kN lbs.		kN lbs.		kN lbs.
23230	1660 372000	0.17	1	281 63240	0.86	242 54390	1	281 63240	1.73	486 109400
23234	2200 494000	0.17	1	373 83980	0.86	321 72220	1	373 83980	1.73	646 145290

NORMAL SPEED RATINGS FOR SEALS

TABLE C-11. V-LOCK SERIES NORMAL SEAL SPEED RATINGS (RPM)

Shaft Dia. mm in.	Bearing No.	Oil Lubrication			Grease Lubrication		
		M/N Seal ⁽¹⁾	T Seal	B/C/O Seal ⁽¹⁾	M/N Seal ⁽¹⁾	T Seal	B/C/O Seal ⁽¹⁾
50 1 15/16, 2	22211	2200	3800	1800	2200	3200	1600
55 2 3/16, 2 1/4	22212	2000	3500	1650	2000	3000	1550
	22213	1800	3200	1500	1800	2800	1500
60, 65 2 7/16, 2 1/2	22214	1700	3050	1400	1700	2600	1400
	22215	1600	2900	1300	1600	2400	1300
70, 75 2 11/16, 2 3/4 2 15/16, 3	22216	1500	2650	1200	1500	2200	1150
	22217	1400	2400	1100	1400	2000	1100
80, 85, 90 3 3/16, 3 1/4 3 7/16, 3 1/2	22219	1300	2200	1000	1300	1800	950
	22220	1200	2000	900	1200	1600	900
100 3 11/16, 3 3/4 3 15/16, 4	22222	900	1700	600	900	1200	600
	22224 22226	700	1500	400	700	1000	400
125, 130 4 15/16, 5	22228	650	1200	350	650	900	350

⁽¹⁾Bearings with contact seals will have higher operating temperatures than bearings with labyrinth seals.

TABLE C-12. CL SERIES NORMAL SEAL SPEED RATINGS (RPM)

Shaft Dia. mm in.	Bearing No.	Oil Lubrication			Grease Lubrication		
		M/N Seal ⁽¹⁾	T Seal	B/C/O Seal ⁽¹⁾	M/N Seal ⁽¹⁾	T Seal	B/C/O Seal ⁽¹⁾
35 1 7/16, 1 1/2	22208	2700	4500	1950	2700	4000	1950
40, 45 1 11/16, 1 3/4	22209	2700	4500	1950	2700	4000	1950
	22210	2400	4200	1800	2400	3550	1800
50 1 15/16, 2	22211	2200	3800	1600	2200	3200	1600
55 2 3/16, 2 1/4	22213	1800	3200	1500	1800	2800	1500
60, 65 2 7/16, 2 1/2	22215	1600	2900	1300	1600	2400	1300
	22218	1400	2400	1000	1400	2000	1000
70, 75 2 11/16, 2 3/4 2 15/16, 3	22220	1200	2000	900	1200	1600	900
	22222	900	1700	600	900	1200	600
110, 115 4 7/16, 4 1/2	22226	700	1500	400	700	1000	400

⁽¹⁾Bearings with contact seals will have higher operating temperatures than bearings with labyrinth seals.

SPHERICAL ROLLER BEARING SOLID-BLOCK HOUSED UNITS

ENGINEERING • NORMAL SPEED RATINGS FOR SEALS

TABLE C-13. EC SERIES NORMAL SEAL SPEED RATINGS (RPM)

Shaft Dia. mm in.	Bearing No.	Oil Lubrication			Grease Lubrication		
		M/N Seal ⁽¹⁾	T Seal	B/C/O Seal ⁽¹⁾	M/N Seal ⁽¹⁾	T Seal	B/C/O Seal ⁽¹⁾
35 1 7/16, 1 1/2	22208	2700	4500	1950	2700	4000	1950
40, 45 1 11/16, 1 3/4	22209	2700	4500	1950	2700	4000	1950
50 1 15/16, 2	22210	2400	4200	1800	2400	3550	1800
55 2 3/16, 2 1/4	22211	2200	3800	1600	2200	3200	1600
60, 65 2 7/16, 2 1/2	22213	1800	3200	1500	1800	2800	1500
70, 75 2 11/16, 2 3/4, 2 15/16, 3	22215	1600	2900	1300	1600	2400	1300
80, 85, 90 3 3/16, 3 1/4, 3 7/16, 3 1/2	22218	1400	2400	1000	1400	2000	1000
100 3 11/16, 3 3/4, 3 15/16, 4	22220	1200	2000	900	1200	1600	900
110, 115 4 7/16, 4 1/2	22222	900	1700	600	900	1200	600
125, 130 4 15/16, 5	22226	700	1500	400	700	1000	400
140, 150 5 7/16, 5 1/2, 5 15/16, 6	23230	650	950	350	600	800	350
170, 180 6 7/16, 6 1/2, 6 15/16, 7	23234	600	900	350	600	800	350

⁽¹⁾Bearings with contact seals will have higher operating temperatures than bearings with labyrinth seals.

TABLE C-14. TA/DV SERIES NORMAL SEAL SPEED RATINGS (RPM)

Shaft Dia. mm in.	Bearing No.	Oil Lubrication			Grease Lubrication		
		M/N Seal ⁽¹⁾	T Seal	B/C/O Seal ⁽¹⁾	M/N Seal ⁽¹⁾	T Seal	B/C/O Seal ⁽¹⁾
40 1 7/16, 1 1/2	22209	2700	4500	1950	2700	4000	1950
45 1 11/16, 1 3/4	22210	2400	4200	1800	2400	3550	1800
50 1 15/16, 2	22211	2200	3800	1800	2200	3200	1600
55 —	22212	2000	3500	1650	2000	3000	1550
60 2 3/16, 2 1/4	22213	1800	3200	1500	1800	2800	1500
65 2 7/16, 2 1/2	22215	1600	2900	1300	1600	2400	1300
70 2 11/16, 2 3/4	22216	1500	2650	1200	1500	2200	1150
75 2 15/16, 3	22217	1400	2400	1100	1400	2000	1100
80 3 3/16, 3 1/4	22218	1400	2400	1000	1400	2000	1000
85 —	22219	1300	2200	1000	1300	1800	950
90 3 7/16, 3 1/2	22220	1200	2000	900	1200	1600	900
100 3 15/16, 4	22222	900	1700	600	900	1200	600
110 4 3/16, 4 1/4	22224	800	1600	500	800	1100	500
115 4 7/16, 4 1/2	22226	700	1500	400	700	1000	400
125 4 15/16, 5	22228	650	1200	350	650	900	350

⁽¹⁾Bearings with contact seals will have higher operating temperatures than bearings with labyrinth seals.

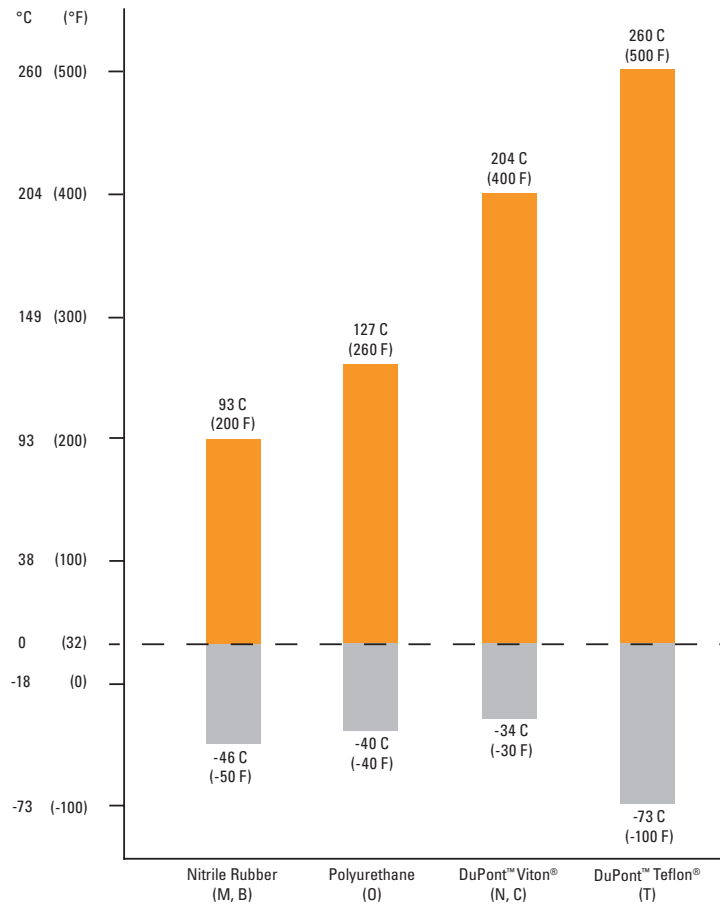

Fig. C-16. Seal temperature ratings based on analytics.

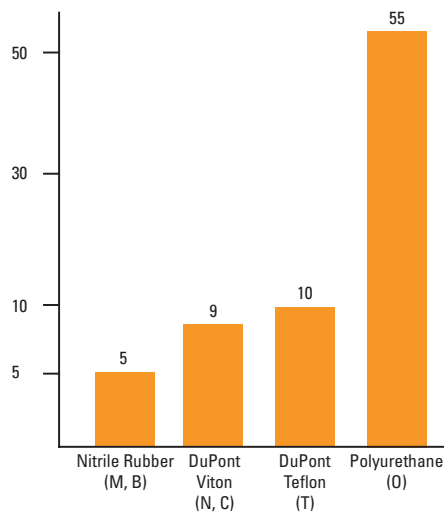

Fig. C-17. Relative abrasion resistance ratings.

DuPont™ is a trademark of E.I. du Pont de Nemours and Company.
 Teflon® is a registered trademark of E.I. du Pont de Nemours and Company.
 Viton® is a registered trademark of E.I. du Pont de Nemours and Company.

SEAL MATERIAL CHEMICAL COMPATIBILITY

A - Little to no effect B - Minor to moderate effect C - Severe effect to destruction N - No data – test prior to use.	Urethane	Nitrile rubber	DuPont™ Viton®	DuPont™ Teflon®
Acetaldehyde	C	C	C	A
Acetamide	N	A	B	A
Acetic Acid	C	B	B	A
Acetic Anhydride	C	C	C	A
Acetone	C	C	C	A
Acetyl Bromide	C	N	N	N
Acetyl Chloride	C	C	A	A
Acetylene	C	A	A	A
Adipic Acid	A	A	N	A
Aero Shell Grease	B	A-B	A	A
Aero Lubriplate	A	A	A	A
Aero Safe 2300	N	C	C	A
Aerzine 50	N	C	C	A
Aluminum Acetate	N	A	C	A
Aluminum Bromide	N	A	A	A
Aluminum Chloride	B	A	A	A
Aluminum Sulfate	B	A	A	A
Ammonia	B	B	C	A
Ammonium Carbonate	B	C	N	A
Ammonium Chloride	N	A	A	A
Ammonium Hydroxide	B	C	A	A
Ammonium Nitrate	B	A	N	A
Ammonium Persulfate	B	C	N	A
Ammonium Sulfate	B	A	C	A
Ammonium Sulfide	B	A	C	A
Ammonium Thiocyanate	B	N	N	A
Ammonium Acetate	C	N	N	A
Amyl Acetate	C	C	C	A
Amyl Alcohol	C	B	C	A
Aniline	C	C	C	A
Aniline Hydrochloride	C	B	B	B
Animal Fats and Oils	B	A	A	A
Antimony Salts	B	N	N	A
Aqua Regia	C	C	B	A
Arsenic Salts	B	N	N	A
ASTM Oil #1	A	A	A	A
ASTM Oil #2	B	A	A	A
ASTM Oil #3	B	A	A	A
ASTM Reference Fuel A	A	A	A	A
ASTM Reference Fuel B	B	B	A	A
Atlantic Oil	A	A	A	A
Barium Carbonate	B	A	A	A
Barium Hydroxide	A	A	A	A
Beer	A	A	A	A
Benzaldehyde	B	C	C	A
Benzene	C	C	B	A
Benzoic Acid	B	C	A	A
Black Sulphate Liquors	N	B	A	A

A - Little to no effect B - Minor to moderate effect C - Severe effect to destruction N - No data – test prior to use.	Urethane	Nitrile rubber	DuPont™ Viton®	DuPont™ Teflon®
Bleach Solutions	N	C	A	B
Boric Acid	A	A	A	A
Brake Fluid	N	C	C	N
Bromine	B	C	A	C
Bunker Oil	A	A	A	A
Butane	A	A	A	A
Butyl Acetate	C	C	C	A
Butyl Alcohol	B	A	A	A
Calcium Carbonate	B	A	A	A
Calcium Chloride	A	A	A	A
Calcium Hydroxide	A	A	A	A
Calcium Nitrate	B	A	A	A
Calcium Sulfate	B	B	B	A
Carbon Dioxide	A	A	A	A
Carbon Disulfide	B	C	A	A
Carbon Monoxide	A	A	A	A
Carbon Tetrachloride	C	C	A	A
Chlorine	N	C	A	B
Chloroacetic Acid	C	C	C	N
Chloroform	C	N	N	B
Chromic Acid	C	C	A	B
Chromium Potassium Sulfate	A	N	N	N
Citric Acid	B	A	A	A
Corn Oil	A	A	A	A
Cottonseed Oil	A	A	A	A
Cresol	C	C	A	A
Crude Oil	B	B	A	A
Cupric Chloride	A	B	B	A
Cupric Nitrate	B	N	N	A
Cupric Sulfate	B	B	B	A
Cutting Oil	B	A	A	A
Cyclohexane	B	A	A	A
Cyclohexanone	C	C	A	A
Dibutyl Phthalate	C	C	C	B
Dichlorobenzene	C	N	N	B
Diesel Fuel	B	A	A	A
Diester Oil	B	B	A	A
Dimethyl Acetamide	C	N	N	A
Dimethyl Formamide	C	B	C	A
Dodecyl Mercaptan	B	N	N	N
DTE Oil	B	A	N	N
Dubutyl Ether	B	C	C	N
EP Lubes	A	A	A	A
Esso #90 Lube Oil	A	A	A	A
Ether	B	N	N	A
Ethyl Acetate	C	C	C	A
Ethyl Alcohol (Ethanol)	C	A	C	A
Formic Acid	C	B	C	A

DuPont™ is a trademark of E.I. du Pont de Nemours and Company.
 Teflon® is a registered trademark of E.I. du Pont de Nemours and Company.
 Viton® is a registered trademark of E.I. du Pont de Nemours and Company.

DISCLAIMER: Every reasonable effort has been made to ensure the accuracy of the information in this writing, but no liability is accepted for errors, omissions or for any other reason.

Continued on next page.

SPHERICAL ROLLER BEARING SOLID-BLOCK HOUSED UNITS

ENGINEERING • SEAL MATERIAL CHEMICAL COMPATIBILITY

Continued from previous page.

A - Little to no effect B - Minor to moderate effect C - Severe effect to destruction N - No data – test prior to use.	Urethane	Nitrile rubber	DuPont™ Viton®	DuPont™ Teflon®
Freon, 12 or 113	A	A	B	A
Fuel Oil	B	A	A	A
Gasoline	B	B	A	A
Glucose	A	A	A	A
Glue	N	A	A	A
Glycerin	A	A	A	A
Heptane	A	N	N	A
Hexane	A	A	A	A
Hydrazine	C	B	C	B
Hydrobromic Acid	B	C	A	A
Hydrocarbon Oil	A	A	A	A
Hydrochloric Acid	B	C	B	A
Hydrofluoric Acid	B	C	C	A
Hydrogen	A	A	A	A
Hydrogen Peroxide	B	C	A	B
Hydrogen Sulfide	C	C	C	A
Hydrologic Acid	B	N	N	N
Iodine	A	B	A	A
Isobutyl Alcohol	N	B	A	A
Isopropyl Chloride	N	C	A	A
Isopropyl Ether	B	B	C	N
Isopropyl Alcohol (Propanol)	B	A	A	N
JP4 Oil	B	A	A	A
JP5 and 6 Oil	C	A	A	A
Kerosene	B	A	A	A
Lactic Acid	B	B	A	A
Lead Acetate	B	B	C	A
Linseed Oil	B	A	A	A
Liquefied Petroleum Gas	A	A	A	N
Lubrication Oil	B	A	A	A
Lye	N	B	B	A
Magnesium Chloride	N	A	A	A
Magnesium Hydroxide	A	B	A	A
Magnesium Salts	B	A	A	A
Maleic Acid	C	C	A	A
Mercury	B	A	A	A
Methyl Alcohol (Methanol)	A	C	A	N
Methyl Ethyl Ketone	C	C	C	A
Methylene Chloride	C	C	B	A
MIL-D-5606 Oil	C	A	A	A
MIL-L7808 Oil	B	B	A	A
Mineral Oil	A	A	A	A
Mineral Spirits	N	B	A	A
Naphthalene	B	C	A	A
Natural Gas	B	A	A	A
Nickel Salts	C	A	A	A
Oxygen	A	B	A	A
Ozone	A	C	A	A

A - Little to no effect B - Minor to moderate effect C - Severe effect to destruction N - No data – test prior to use.	Urethane	Nitrile rubber	DuPont™ Viton®	DuPont™ Teflon®
Palmitic Acid	A	A	A	A
Paint Thinner	B	C	B	A
Peanut Oil	A	A	A	A
Perchloric Acid	C	C	A	A
Perchloroethylene	C	B	A	A
Petroleum	B	A	A	A
Phenol (Carbolic Acid)	C	C	A	A
Phosphoric Acid	C	C	A	A
Potassium Cyanide	A	A	A	A
Potassium Salts	B	A	A	A
Propane	B	A	A	A
Propyl Alcohol	B	A	A	A
Propylene Glycol	B	N	N	A
Pydraul Oil	C	C	A	A
SAE #10 Oil	A	A	A	A
Seawater	A	A	A	A
Silicic Acid	B	N	N	A
Silver Nitrate	B	B	A	A
Skydrol Oil	C	C	C	A
Soap	B	A	A	A
Sodium Acetate	A	B	C	A
Sodium Bicarbonate	B	A	A	A
Sodium Borate	B	A	A	A
Sodium Carbonate	B	A	A	A
Sodium Chloride	B	A	A	A
Sodium Cyanide	B	A	A	A
Sodium Hydrosulfite	B	N	N	A
Sodium Hydroxide	B	B	B	A
Sodium Hypochlorite	C	B	A	A
Sodium Nitrate	B	B	N	A
Sodium Silicate	A	A	A	A
Sodium Sulfate	B	A	A	A
Sodium Sulfide	B	A	A	A
Steam	C	C	C	A
Styrene	B	C	B	A
Sulfur Dioxide	B	C	A	A
Sulfuric Acid	C	C	A	A
Tannic Acid	A	A	A	A
Tartaric Acid	A	A	A	A
Toluene	C	N	N	A
Transformer Oil	B	N	N	A
Turpentine	C	A	A	A
Urea	B	N	N	A
Varnish	B	B	A	A
Water	B	A	A	A

DuPont™ is a trademark of E.I. du Pont de Nemours and Company.

Teflon® is a registered trademark of E.I. du Pont de Nemours and Company.

Viton® is a registered trademark of E.I. du Pont de Nemours and Company.

DISCLAIMER: Every reasonable effort has been made to ensure the accuracy of the information in this writing, but no liability is accepted for errors, omissions or for any other reason.

INTERNAL RADIAL CLEARANCES

TABLE C-15. V-LOCK SERIES (TAPERED BORE, C3)

Shaft Dia.	Bearing No.	Clearance	
		Min.	Max.
mm in.		mm in.	mm in.
50 1 15/16, 2	22211	0.075 0.003	0.095 0.0037
55 2 3/16, 2 1/4	22212	0.075 0.003	0.095 0.0037
55 2 3/16, 2 1/4	22213	0.075 0.003	0.095 0.0037
60, 65 2 7/16, 2 1/2	22214	0.075 0.003	0.095 0.0037
60, 65 2 7/16, 2 1/2	22215	0.075 0.003	0.095 0.0037
70, 75 2 11/16, 2 3/4, 2 15/16, 3	22216	0.095 0.0037	0.120 0.0047
70, 75 2 11/16, 2 3/4, 2 15/16, 3	22217	0.095 0.0037	0.120 0.0047
80, 85, 90 3 3/16, 3 1/4, 3 7/16, 3 1/2	22219	0.110 0.0043	0.140 0.0055
80, 85, 90 3 3/16, 3 1/4, 3 7/16, 3 1/2	22220	0.110 0.0043	0.140 0.0055
100 3 11/16, 3 3/4, 3 15/16, 4	22222	0.135 0.0053	0.170 0.0067
110 —	22224	0.135 0.0053	0.170 0.0067
110, 115 4 7/16, 4 1/2	22226	0.135 0.0053	0.170 0.0067
125, 130 4 15/16, 5	22228	0.160 0.0063	0.200 0.0079

TABLE C-16. CL SERIES (STRAIGHT BORE, C NORMAL)

Shaft Dia.	Bearing No.	Clearance	
		Min.	Max.
mm in.		mm in.	mm in.
35 1 7/16, 1 1/2	22208	0.030 0.0012	0.045 0.0018
40, 45 1 11/16, 1 3/4	22209	0.035 0.0014	0.055 0.0022
50 1 15/16, 2	22210	0.040 0.0016	0.065 0.0026
55 2 3/16, 2 1/4	22211	0.040 0.0016	0.065 0.0026
60, 65 2 7/16, 2 1/2	22213	0.040 0.0016	0.065 0.0026
70, 75 2 11/16, 2 3/4, 2 15/16, 3	22215	0.050 0.002	0.080 0.0031
80, 85, 90 3 3/16, 3 1/4, 3 7/16, 3 1/2	22218	0.060 0.0024	0.100 0.0039
100 3 15/16, 4	22220	0.075 0.003	0.120 0.0047
110, 115 4 7/16, 4 1/2	22222	0.075 0.003	0.120 0.0047
125, 130 4 15/16, 5	22226	0.095 0.0037	0.145 0.0057

TABLE C-17. EC SERIES (STRAIGHT BORE, C NORMAL)

Shaft Dia.	Bearing No.	Clearance		Shaft Dia.	Bearing No.	Clearance	
		Min.	Max.			Min.	Max.
mm in.		mm in.	mm in.	mm in.		mm in.	mm in.
35 1 7/16, 1 1/2	22208	0.030 0.0012	0.045 0.0018	80, 85, 90 3 3/16, 3 1/4 3 7/16, 3 1/2	22218	0.060 0.0024	0.100 0.0039
40, 45 1 11/16, 1 3/4	22209	0.0350 0.0014	0.055 0.0022	100 3 11/16, 3 3/4 3 15/16, 4	22220	0.075 0.003	0.120 0.0047
50 1 15/16, 2	22210	0.040 0.0016	0.065 0.0026	110, 115 4 7/16, 4 1/2	22222	0.075 0.003	0.120 0.0047
55 2 3/16, 2 1/4	22211	0.040 0.0016	0.065 0.0026	125, 130 4 15/16, 5	22226	0.095 0.0037	0.145 0.0057
60, 65 2 7/16, 2 1/2	22213	0.040 0.0016	0.065 0.0026	140, 150 5 7/16, 5 1/2 5 15/16, 6	23230	0.110 0.0043	0.170 0.0067
70, 75 2 11/16, 2 3/4 2 15/16, 3	22215	0.050 0.002	0.080 0.0031	170, 180 6 7/16, 6 1/2, 6 15/16, 7	23234	0.120 0.0047	0.180 0.0071

TABLE C-18. TA/DV SERIES (TAPERED BORE, C3)

Shaft Dia.	Bearing No.	Clearance Prior To Installation		Recommended Reduction Of Internal Radial Clearance		Recommended Axial Movement Of Adapter Sleeve		Minimum Internal
		Min.	Max.	Min.	Max.	Min.	Max.	
mm in.		mm in.	mm in.	mm in.	mm in.	mm in.	mm in.	mm in.
40 1 7/16, 1 1/2	22209	0.061 0.0024	0.079 0.0031	0.025 0.0010	0.030 0.0012	0.381 0.015	0.457 0.018	0.030 0.0012
45 1 11/16, 1 3/4	22210	0.061 0.0024	0.079 0.0031	0.025 0.0010	0.030 0.0012	0.381 0.015	0.457 0.018	0.030 0.0012
50 1 15/16, 2	22211	0.076 0.0030	0.094 0.0037	0.030 0.0012	0.038 0.0015	0.457 0.018	0.559 0.022	0.038 0.0015
55 —	22212	0.076 0.0030	0.094 0.0037	0.030 0.0012	0.038 0.0015	0.457 0.018	0.559 0.022	0.038 0.0015
60 2 3/16, 2 1/4	22213	0.076 0.0030	0.094 0.0037	0.030 0.0012	0.038 0.0015	0.457 0.018	0.559 0.022	0.038 0.0015
65 2 7/16, 2 1/2	22215	0.094 0.0037	0.119 0.0047	0.038 0.0015	0.051 0.0020	0.559 0.022	0.762 0.030	0.043 0.0017
70 2 11/16, 2 3/4	22216	0.094 0.0037	0.119 0.0047	0.038 0.0015	0.051 0.0020	0.559 0.022	0.762 0.030	0.043 0.0017
75 2 15/16, 3	22217	0.109 0.0043	0.140 0.0055	0.046 0.0018	0.064 0.0025	0.686 0.027	0.965 0.038	0.051 0.0020
80 3 3/16, 3 1/4	22218	0.109 0.0043	0.140 0.0055	0.046 0.0018	0.064 0.0025	0.686 0.027	0.965 0.038	0.051 0.0020
85 —	22219	0.109 0.0043	0.140 0.0055	0.046 0.0018	0.064 0.0025	0.686 0.027	0.965 0.038	0.051 0.0020
90 3 7/16, 3 1/2	22220	0.109 0.0043	0.140 0.0055	0.046 0.0018	0.064 0.0025	0.686 0.027	0.965 0.038	0.051 0.0020
100 3 15/16, 4	22222	0.135 0.0053	0.170 0.0067	0.051 0.0020	0.071 0.0028	0.762 0.030	1.067 0.042	0.064 0.0025
110 4 3/16, 4 1/4	22224	0.135 0.0053	0.170 0.0067	0.051 0.0020	0.071 0.0028	0.762 0.030	1.067 0.042	0.064 0.0025
115 4 7/16, 4 1/2	22226	0.160 0.0063	0.201 0.0079	0.064 0.0025	0.089 0.0035	0.889 0.035	1.270 0.050	0.076 0.0030
125 4 15/16, 5	22228	0.160 0.0063	0.201 0.0079	0.064 0.0025	0.089 0.0035	0.889 0.035	1.270 0.050	0.076 0.0030

SHAFTING

When installing and using housed unit bearings, all shafting should be straight, clean, free from burrs and within the recommended shaft tolerances in tables C-19 and C-20 below. For applications that involve high speed or extreme vibration conditions, we recommend that all shafting be machined to one-half the recommended tolerances below.

SHAFT EXPANSION

Steel expands or contracts 0.0000113 millimeter per millimeter for each degree Celsius (0.0000063 inch per inch for each degree Fahrenheit) relative temperature increase or decrease respectively. Expansion bearings are used to accommodate thermal expansion of steel. Where the shafting and the framework on which the bearings and shafting are mounted are made from steel, the relative difference in expansion between the shaft and the

framework will be minimal. In these conditions, fixed bearings can be used on both ends of the shaft. However, if there is a difference in material between the shaft and the framework, or if the application involves different temperatures from the shaft to the frame, then only one fixed bearing should be used on each shaft. All other bearings on the same shaft should be converted to floating to accommodate thermal expansion of the shaft.

TABLE C-19. V-LOCK, CL AND EC SERIES – RECOMMENDED SHAFT TOLERANCES

Shaft Dia.	Shaft Tolerance
mm in.	mm in.
35 1 7/16, 1 1/2	+0.00/-0.025 +0.00/-0.0010
40, 45 1 11/16, 1 3/4	+0.00/-0.038 + 0.00/-0.0015
50 1 15/16, 2	+0.00/-0.038 + 0.00/-0.0015
55 2 3/16, 2 1/4	+0.00/-0.038 + 0.00/-0.0015
60, 65 2 7/16, 2 1/2	+0.00/-0.038 + 0.00/-0.0015
70, 75 2 11/16, 2 3/4, 2 15/16, 3	+0.00/-0.051 + 0.00/-0.0020
80, 85, 90 3 3/16, 3 1/4, 3 7/16, 3 1/2	+0.00/-0.076 + 0.00/-0.0030
100 3 11/16, 3 3/4, 3 15/16, 4	+0.00/-0.076 + 0.00/-0.0030
110, 115 4 7/16, 4 1/2	+0.00/-0.127 + 0.00/-0.0050
125, 130 4 15/16, 5	+0.00/-0.127 + 0.00/-0.0050
140, 150 5 7/16, 5 1/2, 5 15/16, 6	+0.00/-0.127 + 0.00/-0.0050
170, 180 6 7/16, 6 1/2, 6 15/16, 7	+0.00/-0.127 + 0.00/-0.0050

TABLE C-20. TA/DV SERIES – RECOMMENDED SHAFT TOLERANCES

Shaft Dia.	Shaft Tolerance
mm in.	mm in.
40 1 7/16, 1 1/2	+0.00/-0.025 +0.00/-0.0010
45 1 11/16, 1 3/4	+0.00/-0.051 +0.00/-0.0020
50 1 15/16, 2	+0.00/-0.076 + 0.00/-0.0030
55 –	+0.00/-0.076 –
60 2 3/16, 2 1/4	+0.00/-0.076 + 0.00/-0.0030
65 2 7/16, 2 1/2	+0.00/-0.089 + 0.00/-0.0035
70 2 11/16, 2 3/4	+0.00/-0.102 + 0.00/-0.0040
75 2 15/16, 3	+0.00/-0.102 + 0.00/-0.0040
80 3 3/16, 3 1/4	+0.00/-0.102 + 0.00/-0.0040
85 –	+0.00/-0.102 –
90 3 7/16, 3 1/2	+0.00/-0.102 + 0.00/-0.0040
100 3 15/16, 4	+0.00/-0.102 + 0.00/-0.0040
110 4 3/16, 4 1/4	+0.00/-0.102 + 0.00/-0.0040
115 4 7/16, 4 1/2	+0.00/-0.102 + 0.00/-0.0040
125 4 15/16, 5	+0.00/-0.127 + 0.00/-0.0050

TABLE C-21. AMOUNT OF FLOAT PER ONE ROTATION OF EXTERNAL HOUSING NUT

Bearing Number	Float	Bearing Number	Float	Bearing Number	Float
	mm in.		mm in.		mm in.
22208	1.270 0.050	22215	2.108 0.083	22224	2.108 0.083
22209	1.270 0.050	22216	2.108 0.083	22226	2.108 0.083
22210	1.270 0.050	22217	2.108 0.083	22228	2.108 0.083
22211	1.270 0.050	22218	2.108 0.083	23230	2.108 0.083
22212	1.270 0.050	22219	2.108 0.083	23234	2.108 0.083
22213	2.108 0.083	22220	2.108 0.083	–	–
22214	2.108 0.083	22222	2.108 0.083	–	–

CONVERSION FROM FIXED TO FLOATING

Housed unit bearings are easily converted from fixed to floating in the field (see the appropriate installation guide in this catalog for instructions). The following table will help you determine the amount of float for each bearing based on the number of revolutions the external housing nut is backed out.

MISALIGNMENT

All spherical roller bearing housed units utilize self-aligning double-row spherical roller bearings. Because of this, the housed unit can accept up to ±1.5 degrees of misalignment. The performance life of our housed unit is not reduced while under misalignment conditions within these guidelines. It will accept both radial and thrust loads under static, oscillatory or dynamic load conditions.

TABLE C-22. MISALIGNMENT SCALE AT ±1.5 DEGREES

A	B
m in.	mm in.
0.305 1	15.951 0.628
1.524 5	79.756 3.140

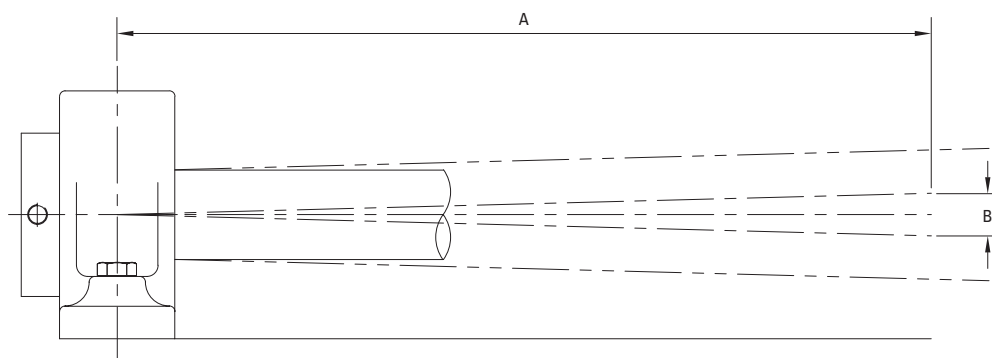

Fig. C-18. Misalignment.

LUBRICATION

Timken is dedicated to using the highest quality components in everything we do. This is why we use premium industrial grease in spherical roller bearing solid-block housed units. The lithium-complex extreme-pressure grease combines the benefits of wide operating temperatures and broad compatibility. This grease offers excellent thermal stability through temperatures ranging from -34° C to 177° C (-30° F to 350° F). When dealing with temperatures above 149° C (300° F), consult your Timken engineer for optional grease recommendations. Application-specific lubrication options are also available ranging from Timken Food Safe Grease (aluminum-complex) to Timken Mill grease (calcium-sulfonate) along with many others.

European REACH Compliance

Timken lubricants, greases and similar products sold in stand-alone containers or delivery systems are subject to the European REACH (Registration, Evaluation, Authorization and Restriction of Chemicals) directive. For import into the European Union, Timken can sell and provide only those lubricants and greases that are registered with ECHA (European Chemical Agency). For further information, please contact your Timken engineer.

INSTALLATION GUIDES

V-LOCK® SERIES

Timken® solid-block housed unit V-Lock® bearings are easy to install and remove because of their unique adapters.

Please complete the following steps to install and/or remove Timken steel housed unit V-Lock bearings. (Refer to fig. C-19.)

- Ensure that the shaft is clean, free from nicks and burrs, straight and of proper diameter. See table C-24 for recommended shaft tolerances. The housed unit should not be mounted on a worn section of the shaft. Using shafts with hardness greater than HRC 45 will reduce the effectiveness of locking devices.
- If using an open-end cover, slide the open-end cover/seal combination into position on the shaft.
- Remove the wedge assembly from the sleeve by unscrewing the wedge nut. See fig. C-19.
- Clean oil off of the sleeve and wedge.
- Apply a thin oil film to the shaft only.
 - For **QV** single-nut housed units:
 - Slide the sleeve, non-threaded end first, into position on the shaft.
 - For **QVV** double-nut housed units:
 - Make sure the sleeve nut is flush with the end of the sleeve.
 - Slide the sleeve/nut assembly, nut end first, into position on the shaft.

- Slide the housed unit into place over the sleeve.
- Loosely install the housed unit mounting bolts. Check the housed unit alignment. Verify that the mounting surfaces are in the same flat plane to help achieve good alignment. If shimming is required to minimize misalignment, use full shims across the entire housing base where possible (fig. C-20). Washers should be properly sized to bolt diameter and should not be an SAE grade, which is smaller.
- Seat the sleeve as best as possible into the mounted unit.
- Tighten the wedge assembly by turning the wedge nut clockwise until tight. Please note that it is designed to prevent overtightening.
- If installing a double-nut housed unit, tighten the sleeve assembly by turning the sleeve nut clockwise until snug.
- Tighten both the wedge nut and sleeve nut set screws alternately according to fig. C-19.
- Install the housed unit mounting bolts. Check the housed unit alignment. Verify that the mounting surfaces are in the same flat plane to achieve good alignment. If shimming is required to minimize misalignment, use full shims across the entire housing base where possible (fig. C-20). The bolts then need to be alternately torqued securely to their mounting supports.
- Tighten the housing mounting bolts.

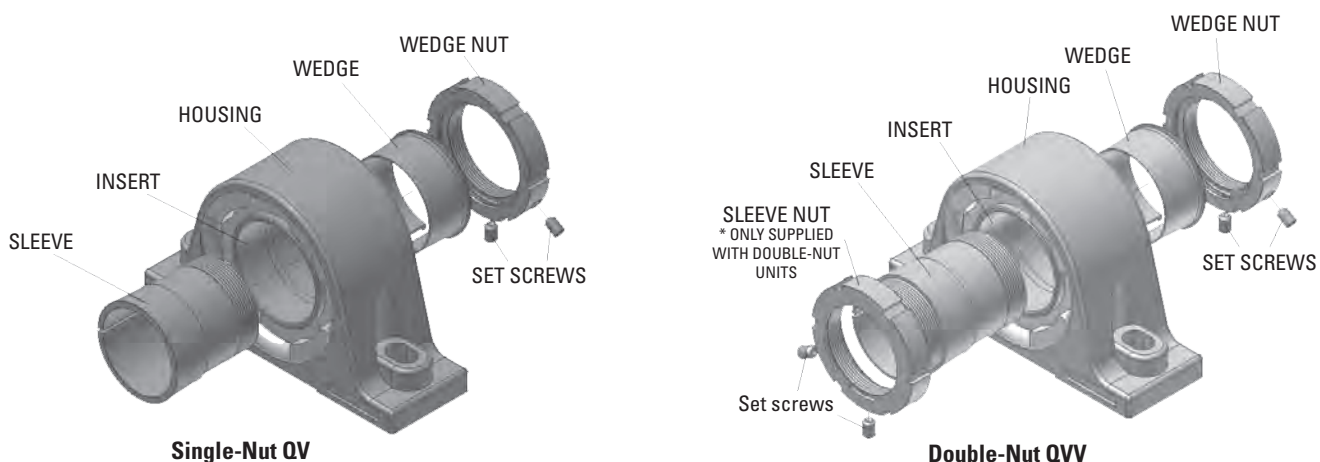

Fig. C-19. V-Lock® insert components.

TABLE C-23. SET SCREW TORQUE VALUES

Bearing Size	Bore	Set Screw Size	Torque
			Nm Nm/in. - lbs.
SLV11 to SLV20	Metric Imperial	M10 X 1.5 3/8-24 TPI	35 32.8/290
SLV22	Metric Imperial	M12 X 1.75 7/16-20 TPI	57 47.5/420
SLV24 to SLV28	Metric Imperial	M12 X 1.75 1/2-20 TPI	57 70.1/620

If using covers:

- Make sure the mating surface of the cover and retaining nuts are clean and dry.
 - Urethane cover: slightly roughen the mating surface of the cover, place a 3 mm – 6 mm (1/8 in. – 1/4 in.) bead of polyurethane adhesive sealant on the roughened surface.
 - Steel cover: place a 3 mm – 6 mm (1/8 in. – 1/4 in.) bead of silicone adhesive sealant on the mating surface of the cover.
- Align the cover mounting holes with the mounting holes on the retaining housing nut (make sure that the grease fitting on the cover is accessible when doing so).
- Apply and tighten the cover mounting hardware.

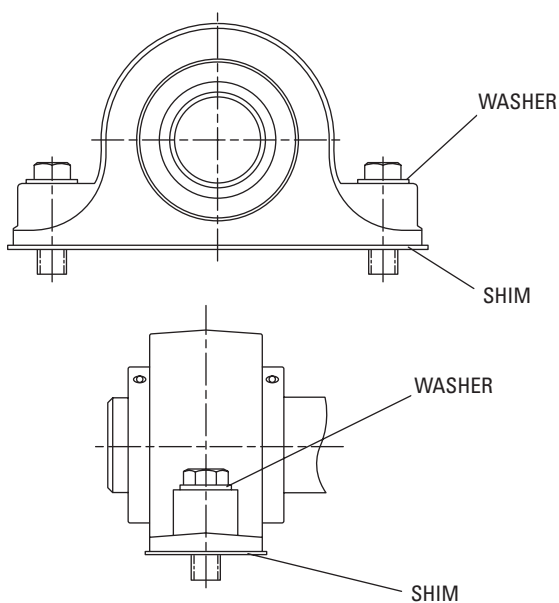

Fig. C-20. Use washers and full shims.

REMOVAL

- Remove covers, if applicable, by removing cover hardware and disengaging the cover from the housed unit retaining nut.
- Loosen the set screws on the wedge nut.
- Turn the wedge nut counterclockwise to remove the wedge from the locked position.
- Completely remove the wedge/wedge nut assembly.
 - For **QV** housed units:
 - Remove the bearing and sleeve from the shaft.
 - For **QVV** housed units:
 - Loosen the set screws on the sleeve nut.
 - Turn the sleeve nut clockwise to un-seat the sleeve.
 - Remove the bearing and sleeve/sleeve nut from the shaft.

TABLE C-24. RECOMMENDED SHAFT TOLERANCES

Shaft Dia.	Bearing No.	Tolerance
mm in.		mm in.
50 1 15/16, 2	22211	+0.00/0.038 +0.00/-0.0015
55 2 3/16, 2 1/4	22212 22213	
60, 65 2 7/16, 2 1/2	22214 22215	
70, 75 2 11/16, 2 3/4, 2 15/16, 3	22216 22217	+0.00/-0.051 +0.00/-0.0020
80, 85, 90 3 3/16, 3 1/4, 3 7/16, 3 1/2	22219 22220	+0.00/-0.076 +0.00/-0.0030
100 3 11/16, 3 15/16, 4	22222	+0.00/-0.076 +0.00/-0.0030
110, 115 4 7/16, 4 1/2	22224 22226	+0.00/-0.127 +0.00/-0.0050
125, 130 4 15/16, 5	22228	

HOW TO CONVERT A SOLID-BLOCK HOUSED UNIT FROM FIXED TO EXPANSION (FLOATING)

Flange Cartridge and Flange Block

- Make a reference mark on the housing and retaining nut.
- Loosen the Teflon-tipped set screw that locks the retaining nut in place.
- Loosen the retaining nut by tapping it with a hammer and punch, rotating the retaining nut counterclockwise one complete revolution.
- Tighten the Teflon-tipped set screw.

Pillow Block

- Decide the amount and direction of expansion that's needed. If unidirectional expansion is required, follow the directions outlined in the previous page for flange housed units on the nut that is on the side you want the expansion.
- If multi-directional expansion is required, follow the directions outlined in the previous section for both nuts on flange housed units.



WARNING

Failure to observe the following warnings could create a risk of death or serious injury.

Proper maintenance and handling practices are critical. Always follow installation instructions and maintain proper lubrication.

Overheated bearings can ignite explosive atmospheres. Special care must be taken to properly select, install, maintain, and lubricate housed unit bearings that are used in or near atmospheres that may contain explosive levels of combustible gases or accumulations of dust such as from grain, coal, or other combustible materials. Consult your equipment designer or supplier for installation and maintenance instructions.

HOW TO CONVERT A SOLID-BLOCK HOUSED UNIT FROM EXPANSION (FLOATING) TO FIXED

Flange Cartridge and Flange Block

- Loosen the Teflon-tipped set screw that locks the retaining nut in place.
- Tighten the retaining nut by tapping it with a hammer and punch, rotating the retaining nut clockwise until it's tight. It is not possible to overtighten the retaining nut.
- Tighten the Teflon-tipped set screw.

NOTE

When converting a solid-block housed unit bearing from fixed to expansion, it is imperative that the unit that is going to be converted is correctly oriented. Since the insert in a steel housed unit flange bearing is held against either a shoulder or snap ring opposite the housing retaining nut, a flange bearing that has been converted to expansion can only float in the direction of the retaining nut. Based on this, the retaining nut must be on the side of the housing opposite the fixed bearing.

Pillow Block

- Follow the directions above for flange housed units on both nuts on either side of the housing.

NOTE

When converting a solid-block housed unit from expansion to fixed on a mounted bearing, the locking-collar set screws must be released to allow the insert to move both in the housing and on the shaft.

LUBRICATION

This information is to aid in the proper lubrication of Timken spherical roller bearing solid-block housed units for the majority of applications.

Housed units have been factory-pretreated with an NLGI No. 2 lithium-complex, extreme-pressure synthetic grease that combines the benefits of wide operating temperatures and broad compatibility with varied materials. This grease offers excellent thermal stability through temperatures ranging from -40° C to 177° C (-40° F to 350° F). Housed units should be relubricated with this grease or one that is compatible and made for roller bearings. It is vital that the greases used are compatible. Please consult with your Timken engineer for the grease specifications if the use of a grease other than the grease mentioned above is needed.

Normal service is considered as operation in a clean, dry environment at temperatures between -34° C to +82° C (-30° F to +180° F). If service is beyond normal conditions due to speed, temperature, or exposure to moisture, dirt or corrosive chemicals,

more frequent relubrication may be necessary. For extreme conditions or conditions in which special chemicals are used, consult with your Timken engineer.

After extended storage or periods when the housed unit is not in operation, fresh grease should be added.

It's important to have the right amount of lubrication, because it affects the housed unit bearing operating temperature as well. An inadequate amount of grease could lead to higher operating temperatures due to inadequate lubrication film thickness. Excessive grease also will lead to higher operating temperatures due to grease churning, which can cause bearing overheating. It is best to observe the bearing and its temperature and adjust the lubrication as needed. If necessary, use the purge valve or seals that purge to reduce the amount of grease.

NOTE

Please check with the manufacturer of your grease delivery system for specific information.

RELUBRICATION

Adequate lubrication is an essential element to the housed unit bearing life. Use table C-25 as a suggested initial point of reference. Relubrication frequency and quantity intervals are best determined through experience for each application, based on types of service, which may differ from the suggestions in the table.

When the housed unit is not in operation for an extended period of time, grease should be added to prevent corrosion.

Table C-25 shows general lubrication suggested starting points only. Please read the entire installation instructions prior to using these tables. Applications should be regularly reviewed and lubrication amounts and intervals modified as needed to ensure best results.

TABLE C-25. RELUBRICATION INTERVALS

Shaft Diameter	Bearing No.	Initial Weight	Relubrication Weight	Relubrication Interval (Hours of Service based on RPM and Temperature deg. F)											
				100 RPM		250 RPM		500 RPM		1000 RPM		2000 RPM		3000 RPM	
				<160°	>160°	<160°	>160°	<160°	>160°	<160°	>160°	<160°	>160°	<160°	>160°
mm in.		g oz.	g oz.												
50 1 15/16, 2	22211	28.4 1	8.5 0.3	1200	600	800	400	440	220	160	80	100	50	60	30
55 2 3/16, 2 1/4	22212	34.0 1.2	8.5 0.3	1150	580	750	380	400	200	140	70	90	50	50	20
	22213	36.9 1.3	11.3 0.4	1130	570	740	370	380	190	130	65	85	45	45	20
60, 65 2 7/16, 2 1/2	22214	39.7 1.4	11.3 0.4	1120	560	720	360	360	180	120	60	80	40	40	20
	22215	56.7 2	14.2 0.5	1080	540	700	350	350	175	110	55	70	35		
70, 75 2 11/16, 2 3/4 2 15/16, 3	22216	76.5 2.7	19.9 0.7	1040	520	680	340	340	170	100	50	60	30		
	22217	96.4 3.4	25.5 0.9	1000	500	640	320	320	160	100	50	60	30		
80, 85, 90 3 3/16, 3 1/4 3 7/16, 3 1/2	22219	104.9 3.7	25.5 0.9	960	480	600	300	300	150	80	40	40	20		
	22220	184.3 6.5	45.4 1.6	840	420	520	260	240	120	70	35	30	18		
100 3 11/16, 3 3/4 3 15/16, 4	22222	209.8 7.4	53.9 1.9	680	340	440	220	200	100	60	30	20	16		
110, 115 4 7/16, 4 1/2	22224	260.8 9.2	68.0 2.4	640	320	400	200	180	90	50	25				
	22226	300.5 10.6	76.5 2.7	560	280	360	180	160	80						
125, 130 4 15/16, 5	22228	396.9 14	99.2 3.5	520	260	340	170	140	75						

DISCLAIMER: Every reasonable effort has been made to ensure the accuracy of the information in this writing, but no liability is accepted for errors, omissions or for any other reason.

CL SERIES

Please complete the following steps to install Timken solid-block housed unit CL Series bearings.

- Ensure that the shaft is clean, free from nicks and burrs, straight and of proper diameter. See table C-26 for recommended shaft tolerances. The housed unit should not be mounted on a worn section of the shaft. Using shafts with hardness greater than HRC 45 will reduce the effectiveness of locking devices.
- If using an open-end cover, slide the open-end cover/seal combination into position on the shaft.
- Apply a thin oil film to the shaft and bearing bore.
- Slide the housed unit into position on the shaft.
- Install the housed unit mounting bolts. Check the housed unit alignment. Verify mounting surfaces are in the same flat plane to help achieve good alignment. If shimming is required to minimize misalignment, use full shims across the entire housing base where possible (fig. C-22). The bolts then need to be alternately torqued securely to their mounting supports.
- Tighten set screws alternately as per table C-27. Set screws in multiple units should be aligned to each other (fig. C-21).

If using covers:

- Make sure the mating surface of the cover and retaining nuts are clean and dry.
 - Urethane cover: slightly roughen the mating surface of the cover, place a 3 mm – 6 mm (1/8 in. – 1/4 in.) bead of polyurethane adhesive sealant on the roughened surface.
 - Steel cover: place a 3 mm – 6 mm (1/8 in. – 1/4 in.) bead of silicone adhesive sealant on the mating surface of the cover.
- Align the cover mounting holes with the mounting holes on the retaining housing nut (make sure that the grease fitting on the cover is accessible when doing so).
- Apply and tighten the cover mounting hardware.

TABLE C-26. RECOMMENDED SHAFT TOLERANCES

Shaft Dia.	Bearing No.	Tolerance
mm in.		mm in.
35 1 7/16, 1 1/2	22208	+0.00/-0.025 +0.00/0.0010
40, 45 1 1/16, 1 3/4	22209	+0.00/-0.038 +0.00/0.0015
50 1 15/16, 2	22210	+0.00/-0.038 +0.00/-0.0015
55 2 3/16, 2 1/4	22211	+0.00/-0.038 +0.00/-0.0015
60, 65 2 7/16, 2 1/2	22213	+0.00/-0.038 +0.00/-0.0015
70, 75 2 11/16, 2 3/4 2 15/16, 3	22215	+0.00/-0.51 +0.00/-0.0020
80, 85, 90 3 3/16, 3 1/4 3 7/16, 3 1/2	22218	+0.00/-0.076 +0.00/-0.0030
100 3 15/16, 4	22220	+0.00/-0.076 +0.00/-0.0030
110, 115 4 7/16, 4 1/2	22222	+0.00/-0.127 +0.00/-0.0050
125, 130 4 15/16, 5	22226	+0.00/-0.127 +0.00/-0.0050

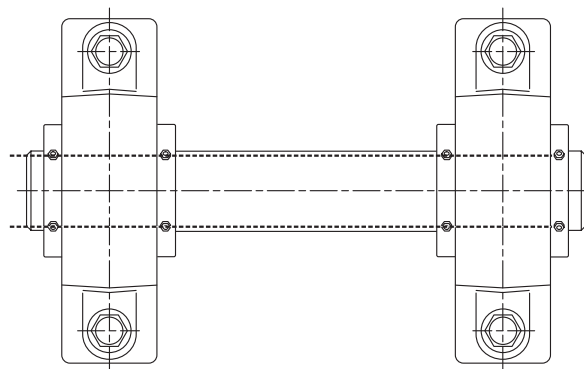

Fig. C-21. Line up set screws in multiple units.

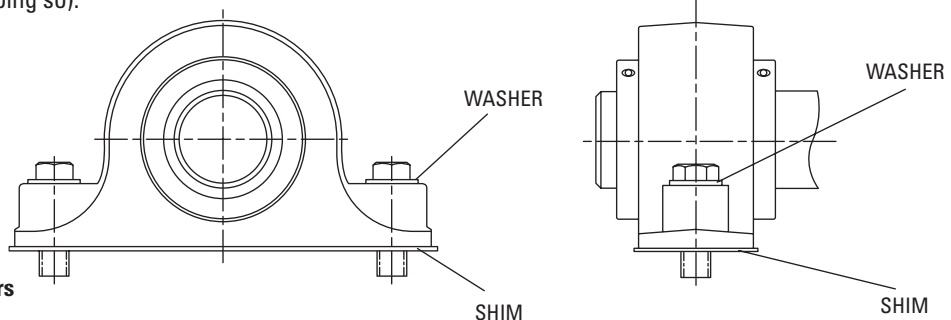

Fig. C-22. Use washers and full shims.

TABLE C-27. SET SCREW TORQUE VALUES

Shaft Dia.	Bearing No.	Set Screw Size	Torque
mm in.		mm in.	Nm Nm/in. - lbs.
35 1 7/16, 1 1/2	22208	M10 X 1.5 3/8 - 24 TPI	35 32.8/290
40, 45 1 11/16, 1 3/4	22209	M10 X 1.5 3/8 - 24 TPI	35 32.8/290
50 1 15/16, 2	22210	M10 X 1.5 3/8 - 24 TPI	35 32.8/290
55 2 3/16, 2 1/4	22211	M10 X 1.5 3/8 - 24 TPI	35 32.8/290
60, 65 2 7/16, 2 1/2	22213	M12 X 1.75 1/2 - 20 TPI	57 70.1/620
70, 75 2 11/16, 2 3/4 2 15/16, 3	22215	M12 X 1.75 1/2 - 20 TPI	57 70.1/620
80, 85, 90 3 3/16, 3 1/4 3 7/16, 3 1/2	22218	M12 X 1.75 1/2 - 20TPI	57 70.1/620
100 3 15/16, 4	22220	M16 X 2 5/8 - 18 TPI	126 149.7/1325
110, 115 4 7/16, 4 1/2	22222	M16 X 2 5/8 - 18 TPI	126 149.7/1325
125, 130 4 15/16, 5	22226	M16 X 2 5/8 - 18 TPI	126 149.7/1325

LUBRICATION

This information is to aid in the proper lubrication of Timken spherical roller bearing solid-block housed units for the majority of applications.

Housed units have been factory-prelubricated with an NLGI No. 2 lithium-complex, extreme pressure synthetic grease that combines the benefits of wide operating temperatures and broad compatibility with varied materials. This grease offers excellent thermal stability through temperatures ranging from -40° C to 177° C (-40° F to 350° F). Housed units should be relubricated with this grease or one that is compatible and made for roller bearings. It is vital that the greases used are compatible. Please consult with your Timken engineer for the grease specifications if the use of a grease other than the grease mentioned above is needed.

Normal service is considered as operation in a clean, dry environment at temperatures between -34° C to +82° C (-30° F to +180° F). If service is beyond normal conditions due to speed, temperature, or exposure to moisture, dirt or corrosive chemicals, periodic relubrication may be necessary. For extreme conditions or conditions in which special chemicals are used, consult with your Timken engineer.

After extended storage or periods when the housed unit is not in operation, fresh grease should be added.

It's important to have the right amount of lubrication, because it affects the housed unit bearing operating temperature as well. An inadequate amount of grease could lead to higher operating temperatures due to inadequate lubrication film thickness. Excessive grease also will lead to higher operating temperatures due to grease churning, which can cause bearing overheating. It is best to observe the bearing and its temperature and adjust the lubrication as needed. If necessary, use the purge valve or seals that purge to reduce the amount of grease.

NOTE

Please check with the manufacturer of your grease delivery system for specific information.



WARNING

Failure to observe the following warnings could create a risk of death or serious injury.

Proper maintenance and handling practices are critical. Always follow installation instructions and maintain proper lubrication.

Overheated bearings can ignite explosive atmospheres. Special care must be taken to properly select, install, maintain, and lubricate housed unit bearings that are used in or near atmospheres that may contain explosive levels of combustible gases or accumulations of dust such as from grain, coal, or other combustible materials. Consult your equipment designer or supplier for installation and maintenance instructions.

RELUBRICATION

Adequate lubrication is an essential element to the housed unit bearing life. Use table C-28 as a suggested initial point of reference. Relubrication frequency and quantity intervals are best determined through experience for each application based on types of service, which may differ from the suggestions in the table.

When the housed unit is not in operation for an extended period of time, grease should be added to prevent corrosion.

Table C-28 shows general lubrication suggested starting points only. Please read the entire installation instructions prior to using

these tables. Applications should be regularly reviewed and lubrication amounts and intervals modified as needed to ensure the best results.

TABLE C-28. RELUBRICATION INTERVALS

Shaft Dia.	Bearing No.	Initial Weight	Relubrication Weight	Relubrication Interval (Hours of Service based on RPM and Temperature deg. F)											
				100 RPM		250 RPM		500 RPM		1000 RPM		2000 RPM		3000 RPM	
				<160°	>160°	<160°	>160°	<160°	>160°	<160°	>160°	<160°	>160°	<160°	>160°
mm in.		g oz.	g oz.												
35 1 7/16, 1 1/2	22208	14.2 0.5	2.4 0.1	2200	1000	1400	700	1000	500	240	120	120	60	40	20
40, 45 1 11/16, 1 3/4	22209	317.5 0.7	5.7 0.2	2000	1000	1200	600	800	400	320	160	160	80	80	40
50 1 15/16, 2	22210	22.7 0.8	5.7 0.2	1600	800	1000	500	640	320	240	120	120	60	60	30
55 2 3/16, 2 1/4	22211	28.4 1	8.5 0.3	1200	600	800	400	440	220	160	80	100	50	60	30
60, 65 2 7/16, 2 1/2	22213	39.7 1.4	11.3 0.4	1120	560	720	360	360	180	120	60	80	40	40	20
70, 75 2 11/16, 2 3/4 2 15/16, 3	22215	76.5 2.7	19.4 0.7	1040	520	680	340	340	170	100	50	60	30		
80, 85, 90 3 3/16, 3 1/4 3 7/16, 3 1/2	22218	104.9 3.7	25.5 0.9	960	480	600	300	300	150	80	40	40	20		
100 3 15/16, 4	22220	184.3 6.5	45.4 1.6	840	420	520	260	240	120	60	30	20	16		
110, 115 4 7/16, 4 1/2	22222	209.8 7.4	53.9 1.9	680	340	440	220	200	100	60	30	20	16		
125, 130 4 15/16, 5	22226	300.5 10.6	76.5 2.7	560	280	360	180	160	80						

DISCLAIMER: Every reasonable effort has been made to ensure the accuracy of the information in this writing, but no liability is accepted for errors, omissions or for any other reason.

HOW TO CONVERT A SOLID-BLOCK HOUSED UNIT FROM FIXED TO EXPANSION (FLOATING)

Flange Cartridge and Flange Block

- Make a reference mark on the housing and retaining nut.
- Loosen the Teflon-tipped set screw that locks the retaining nut in place.
- Loosen the retaining nut by tapping it with a hammer and punch, rotating the retaining nut counterclockwise one complete revolution.
- Tighten the Teflon-tipped set screw.

NOTE

When converting a solid-block housed unit bearing from fixed to expansion, it is imperative that the unit that is going to be converted is correctly oriented. Since the insert in a steel housed unit flange bearing is held against either a shoulder or snap ring opposite the housing retaining nut, a flange bearing that has been converted to expansion can only float in the direction of the retaining nut. Based on this, the retaining nut must be on the side of the housing opposite the fixed bearing.

Pillow Block

- Decide the amount and direction of expansion that's needed. If unidirectional expansion is required, follow the directions outlined above for flange bearings on the nut that is on the side you want the expansion.
- If multi-directional expansion is required, follow the directions as outlined above for both nuts on flange housed units.

HOW TO CONVERT A SOLID-BLOCK HOUSED UNIT FROM EXPANSION (FLOATING) TO FIXED

Flange Cartridge and Flange Block

- Loosen the Teflon-tipped set screw that locks the retaining nut in place.
- Tighten the retaining nut by tapping it with a hammer and punch, rotating the retaining nut clockwise until it's tight. It is not possible to overtighten the retaining nut.
- Tighten the Teflon-tipped set screw.

Pillow Block

- Follow the directions above for flange bearings on both nuts on either side of the housing.

NOTE

When converting a solid-block housed unit from expansion to fixed on a mounted bearing, the locking-collar set screws must be released to allow the insert to move both in the housing and on the shaft.

EC SERIES

Please complete the following steps to install Timken EC series spherical roller bearing solid-block housed units.

- Ensure that the shaft is clean, free from nicks and burrs, straight and of proper diameter. See table C-29 for recommended shaft tolerances. The housed unit should not be mounted on a worn section of the shaft. Using shafts with hardness greater than HRC 45 will reduce the effectiveness of locking devices.
- If using an open-end cover, slide the open-end cover/seal combination into position on the shaft.
- Apply a thin oil film to the shaft and bearing bore.
- Slide the housed unit into position on the shaft.
- Install the housed unit mounting bolts. Check the housed unit alignment. Verify that the mounting surfaces are in the same flat plane to help achieve good alignment. If shimming is required to minimize misalignment, use full shims across the entire housing base where possible (fig. C-23). The bolts then need to be alternately torqued securely to their mounting supports.

- Slide the eccentric locking collar along shaft and onto the extended portion of the bearing's inner ring.
- Rotate the eccentric locking collar until it is hand-tight (the direction of rotation does not matter).
- Lock the eccentric locking collar firmly in place by using a spanner wrench or a hammer and drift.

When using a hammer and drift, one or two firm, but not too hard, blows will be sufficient due to the shallow eccentric ramp on EC series housed units. Make sure you drive the collar in the same direction in which you hand-tightened it so as to turn it to a tighter position on the bearing's inner ring.

- Tighten the eccentric locking collar set screws alternately as per table C-30.

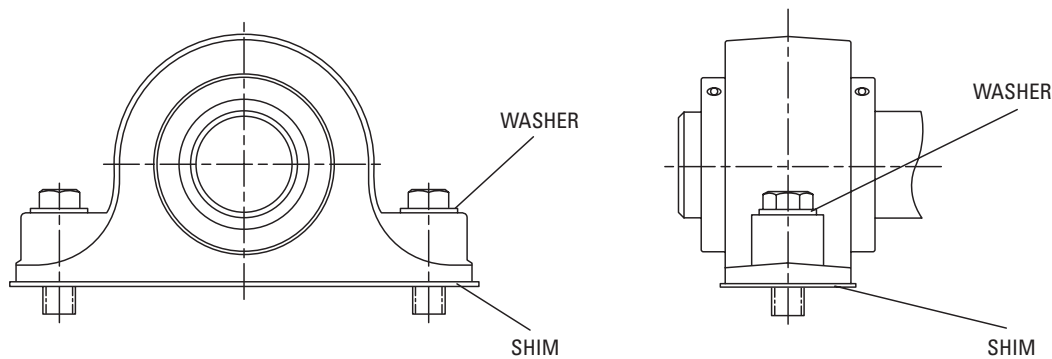

Fig. C-23. Use washers and full shims.

If using covers:

- Make sure the mating surface of the cover and retaining nuts are clean and dry.
 - Urethane cover: slightly roughen the mating surface of the cover, place a 3 mm – 6 mm (1/8 in. – 1/4 in.) bead of polyurethane adhesive sealant on the roughened surface.
 - Steel cover: place a 3 mm – 6 mm (1/8 in. – 1/4 in.) bead of silicone adhesive sealant on the mating surface of the cover.
- Align the cover mounting holes with the mounting holes on the retaining housing nut (make sure that the grease fitting on the cover is accessible when doing so).
- Apply and tighten the cover mounting hardware.

TABLE C-29. RECOMMENDED SHAFT TOLERANCES

Shaft Dia.	Bearing No.	Tolerance
mm in.		mm in.
35 1 7/16, 1 1/2	22208	+0.00/-0.025 +0.00/-0.0010
40, 45 1 11/16, 1 3/4	22209	+0.00/-0.038 +0.00/-0.0015
50 1 15/16, 2	22210	+0.00/-0.038 +0.00/-0.0015
55 2 3/16, 2 1/4	22211	+0.00/-0.038 +0.00/-0.0015
60, 65 2 7/16, 2 1/2	22213	+0.00/-0.038 +0.00/-0.0015
70, 75 2 11/16, 2 3/4 2 15/16, 3	22215	+0.00/-0.051 +0.00/-0.0020
80, 85, 90 3 3/16, 3 1/4 3 7/16, 3 1/2	22218	+0.00/-0.076 +0.00/-0.0030
100 3 11/16, 3 3/4 3 15/16, 4	22220	+0.00/-0.076 +0.00/-0.0030
110, 115 4 7/16, 4 1/2	22222	+0.00/-0.127 +0.00/-0.0050
125, 130 4 15/16, 5	22226	+0.00/-0.127 +0.00/-0.0050
140, 150 5 7/16, 5 1/2 5 15/16, 6	23230	+0.00/-0.127 +0.00/-0.0050
170, 180 6 7/16, 6 1/2 6 15/16, 7	23234	+0.00/-0.127 +0.00/-0.0050

TABLE C-30. SET SCREW TORQUE VALUES

Shaft Dia.	Bearing No.	Set Screw Size	Torque
mm in.		mm in.	Nm Nm/in. - lbs.
35 1 7/16, 1 1/2	22208	M8 X 1.25 5/16 - 24 TPI	17.8 18.6/165
40, 45 1 11/16, 1 3/4	22209	M10 X 1.5 3/8 - 24 TPI	35 32.8/290
50 1 15/16, 2	22210	M10 X 1.5 3/8 - 24 TPI	35 32.8/290
55 2 3/16, 2 1/4	22211	M10 X 1.5 3/8 - 24 TPI	35 32.8/290
60, 65 2 7/16, 2 1/2	22213	M12 X 1.75 7/16 - 20 TPI	57 70.1/620
70, 75 2 11/16, 2 3/4 2 15/16, 3	22215	M12 X 1.75 7/16 - 20 TPI	57 70.1/620
80, 85, 90 3 3/16, 3 1/4 3 7/16, 3 1/2	22218	M12 X 1.75 7/16 - 20 TPI	57 70.1/620
100 3 11/16, 3 3/4 3 15/16, 4	22220	M16 X 2 5/8 - 18 TPI	126 149.7/1325
110, 115 4 7/16, 4 1/2	22222	M16 X 2 5/8 - 18 TPI	126 149.7/1325
125, 130 4 15/16, 5	22226	M16 X 2 5/8 - 18 TPI	126 149.7/1325
140, 150 5 7/16, 5 1/2 5 15/16, 6	23230	M16 X 2 5/8 - 18 TPI	126 149.7/1325
170, 180 6 7/16, 6 1/2 6 15/16, 7	23234	M16 X 2 5/8 - 18 TPI	126 149.7/1325

LUBRICATION

This information is to aid in the proper lubrication of Timken spherical roller bearing solid-block housed units for the majority of applications.

Housed units have been factory-prelubricated with an NLGI No. 2 lithium-complex, extreme-pressure synthetic grease that combines the benefits of wide operating temperatures and broad compatibility with varied materials. This grease offers excellent thermal stability through temperatures ranging from -40° C to 177° C (-40° F to 350° F). Housed units should be relubricated with this grease or one that is compatible and made for roller bearings. It is vital that the greases used are compatible. Please consult with your Timken engineer for the grease specifications if the use of a grease other than the grease mentioned above is needed.

Normal service is considered as operation in a clean, dry environment at temperatures between -34° C to +82° C (-30° F to +180° F). If service is beyond normal conditions due to speed, temperature, or exposure to moisture, dirt or corrosive chemicals, periodic relubrication may be necessary. For extreme conditions or conditions in which special chemicals are used, consult with your Timken engineer.

After extended storage or periods when the housed unit is not in operation, fresh grease should be added.

It's important to have the right amount of lubrication, because it affects the housed unit bearing operating temperature as well. An inadequate amount of grease could lead to higher operating temperatures due to inadequate lubrication film thickness. Excessive grease also will lead to higher operating temperatures due to grease churning, which can cause bearing overheating. It is best to observe the bearing and its temperature and adjust the lubrication as needed. If necessary, use the purge valve or seals that purge to reduce the amount of grease.

NOTE

Please check with the manufacturer of your grease delivery system for specific information.

RELUBRICATION

Adequate lubrication is an essential element to the housed unit bearing life. Use table C-31 as a suggested initial point of reference. Relubrication frequency and quantity intervals are best developed through experience for each application based on types of service, which may differ from the suggestions in the table.

When the housed unit is not in operation for an extended period of time, grease should be added to prevent corrosion.

Table C-31 shows general lubrication suggested starting points only. Please read the entire installation instructions prior to using these tables. Applications should be regularly reviewed and lubrication amounts and intervals modified as needed to ensure the best results.



WARNING

Failure to observe the following warnings could create a risk of death or serious injury.

Proper maintenance and handling practices are critical. Always follow installation instructions and maintain proper lubrication.

Overheated bearings can ignite explosive atmospheres. Special care must be taken to properly select, install, maintain, and lubricate housed unit bearings that are used in or near atmospheres that may contain explosive levels of combustible gases or accumulations of dust such as from grain, coal, or other combustible materials. Consult your equipment designer or supplier for installation and maintenance instructions.

DISCLAIMER

Every reasonable effort has been made to ensure the accuracy of the information in this writing, but no liability is accepted for errors, omissions or for any other reason.

TABLE C-31. RELUBRICATION INTERVALS

Shaft Dia.	Bearing No.	Initial Weight	Relubrication Weight	Relubrication Interval (Hours of Service based on RPM and Temperature deg. F)											
				100 RPM		250 RPM		500 RPM		1000 RPM		2000 RPM		3000 RPM	
				<160°	>160°	<160°	>160°	<160°	>160°	<160°	>160°	<160°	>160°	<160°	>160°
mm in.		g oz.	g oz.												
35 1 7/16, 1 1/2	22208	14.2 0.5	2.8 0.1	2200	1000	1400	700	1000	500	240	120	120	60	40	20
40, 45 1 11/16, 1 3/4	22209	19.9 0.7	5.7 0.2	2000	1000	1200	600	800	400	320	160	160	80	80	40
50 1 15/16, 2	22210	22.7 0.8	5.7 0.2	1600	800	1000	500	640	320	240	120	120	60	60	30
55 2 3/16, 2 1/4	22211	28.4 1	8.5 0.3	1200	600	800	400	440	220	160	80	100	50	60	30
60, 65 2 7/16, 2 1/2	22213	39.7 1.4	11.3 0.4	1120	560	720	360	360	180	120	60	80	40	40	20
70, 75 2 11/16, 2 3/4 2 15/16, 3	22215	76.5 2.7	19.8 0.7	1040	520	680	340	340	170	100	50	60	30		
80, 85, 90 3 3/16, 3 1/4 3 7/16, 3 1/2	22218	104.9 3.7	25.5 0.9	960	480	600	300	300	150	80	40	40	20		
100 3 11/16, 3 3/4 3 15/16, 4	22220	184.3 6.5	45.4 1.6	840	420	520	260	240	120	60	30	20	16		
110, 115 4 7/16, 4 1/2	22222	209.8 7.4	53.9 1.9	680	340	440	220	200	100	60	30	20	16		
125, 130 4 15/16, 5	22226	300.5 10.6	76.5 2.7	560	280	360	180	160	80						
140, 150 5 7/16, 5 1/2 5 15/16, 6	23230	589.7 20.8	147.4 5.2	480	240	320	160	120	68						
170, 180 6 7/16, 6 1/2 6 15/16, 7	23234	850 30.0	241.0 8.5	400	160	240	160	110	60						

HOW TO CONVERT A SOLID-BLOCK HOUSED UNIT FROM FIXED TO EXPANSION (FLOATING)

Flange Cartridge and Flange Block

- Make a reference mark on the housing and retaining nut.
- Loosen the Teflon-tipped set screw that locks the retaining nut in place.
- Loosen the retaining nut by tapping it with a hammer and punch, rotating the retaining nut counterclockwise one complete revolution.
- Tighten the Teflon-tipped set screw.

NOTE

When converting a solid-block housed unit bearing from fixed to expansion, it is imperative that the unit that is going to be converted is correctly oriented. Since the insert in a steel housed unit flange bearing is held against either a shoulder or snap ring opposite the housing retaining nut, a flange bearing that has been converted to expansion can only float in the direction of the retaining nut. Based on this, the retaining nut must be on the side of the housing opposite the fixed bearing.

Pillow Block

- Decide the amount and direction of expansion that's needed. If unidirectional expansion is required, follow the directions outlined above for flange bearings on the nut that is on the side you want the expansion.
- If multi-directional expansion is required, follow the directions outlined above for both nuts on flange housed units.

HOW TO CONVERT A SOLID-BLOCK HOUSED UNIT FROM EXPANSION (FLOATING) TO FIXED

Flange Cartridge and Flange Block

- Loosen the Teflon-tipped set screw that locks the retaining nut in place.
- Tighten the retaining nut by tapping it with a hammer and punch, rotating the retaining nut clockwise until it's tight. It is not possible to overtighten the retaining nut.
- Tighten the Teflon-tipped set screw.

Pillow Block

- Follow the directions above for flange bearings on both nuts on either side of the housing.

NOTE

When converting a solid-block housed unit from expansion to fixed on a mounted bearing, the locking collar set screws must be released to allow the insert to move both in the housing and on the shaft.

TA/DV SERIES

Choose one of the following two methods for installing your housed unit depending on your situation. Timken recommends the axial drive-up method for most applications. If your application is not as critical, the simpler tang counting method is fine.

AXIAL DRIVE-UP METHOD

- Clean all components of any debris and apply a thin oil film to all mating surfaces to ensure proper seating.
- If using an open-end cover, slide the open-end cover/seal combination into position on the shaft.
- Slide the adapter sleeve into position on the shaft, then put the housed unit into place on the adapter sleeve.
- Loosely install the housed unit mounting bolts. Check the housed unit alignment. Verify mounting surfaces are in the same flat plane to help achieve good alignment. If shimming is required to minimize misalignment, use full shims across the entire housing base where possible (fig. C-24). Washers should be properly sized to the bolt diameter and should not be an SAE grade, which is smaller.
- Put the lockwasher on and thread the locknut onto the adapter sleeve leaving approximately 6.350 mm (¼ in.) between the lockwasher and the inner ring of the bearing.
- Use a large screwdriver or pry bar to lever the sleeve into position until there is no relative movement between the shaft, the adapter sleeve, and the bearing's inner ring.
- Rotate the locknut until hand-tight.
- Tighten the locknut while using a dial indicator to measure the axial movement of the tapered adapter sleeve relative to the bearing's inner ring (see table C-32).
- Bend a tang on the lockwasher into a slot on the locknut to prevent the locknut from loosening.
- Tighten the housed unit mounting bolts.

If using covers:

- Make sure the mating surface of the cover and retaining nuts are clean and dry.
 - Urethane cover: slightly roughen the mating surface of the cover, place a 3 mm – 6 mm (⅛ in. – ¼ in.) bead of polyurethane adhesive sealant on the roughened surface.
 - Steel cover: place a 3 mm – 6 mm (⅛ in. – ¼ in.) bead of silicone adhesive sealant on the mating surface of the cover.
- Align the cover mounting holes with the mounting holes on the retaining housing nut (make sure that the grease fitting on the cover is accessible when doing so).
- Apply and tighten the cover mounting hardware.

TABLE C-32. AXIAL MOVEMENT OF TAPERED ADAPTER SLEEVE RELATIVE TO INNER RING

Shaft Dia.	Bearing No.	Minimum Axial Movement	Maximum Axial Movement
mm in.		mm in.	mm in.
40 1 7/16, 1 1/2	22209	0.38 0.015	0.46 0.018
45 1 11/16, 1 3/4	22210	0.38 0.015	0.46 0.018
50 1 15/16, 2	22211	0.46 0.018	0.56 0.022
55 —	22212	0.46 0.018	0.56 0.022
60 2 3/16, 2 1/4	22213	0.46 0.018	0.56 0.022
65 2 7/16, 2 1/2	22215	0.64 0.025	0.76 0.030
70 2 11/16, 2 3/4	22216	0.64 0.025	0.76 0.030
75 2 15/16, 3	22217	0.69 0.027	0.97 0.038
80 3 3/16, 3 1/4	22218	0.69 0.027	0.97 0.038
85 —	22219	0.69 0.027	0.97 0.038
90 3 7/16, 3 1/2	22220	0.69 0.027	0.97 0.038
100 3 15/16, 4	22222	0.76 0.030	1.07 0.042
110 4 3/16, 4 1/4	22224	0.76 0.030	1.07 0.042
115 4 7/16, 4 1/2	22226	0.89 0.035	1.27 0.050
125 4 15/16, 5	22228	0.89 0.035	1.27 0.050

TANG COUNTING METHOD

- Clean all components of any debris and apply a thin oil film to all mating surfaces to ensure proper seating.
- If using an open-end cover, slide the open-end cover/seal combination into position on the shaft.
- Slide the adapter sleeve into the correct position on the shaft, then put the housed unit into place on the adapter sleeve.
- Loosely install the housed unit mounting bolts. Check the housed unit alignment. Verify mounting surfaces are in the same flat plane to help achieve good alignment. If shimming is required to minimize misalignment, use full shims across the entire housing base where possible (fig. C-24). Washers should be properly sized to the bolt diameter and should not be an SAE grade, which is smaller.
- Put the lockwasher on and thread the locknut onto the adapter sleeve, leaving approximately $\frac{1}{4}$ in. between the lockwasher and the inner ring of the bearing.
- Use a large screwdriver or pry bar to lever the sleeve into position until there is no relative movement between the shaft, the adapter sleeve and the bearing's inner ring.
- Rotate the locknut until hand-tight.
- Note which tang is in line with one slot on the locknut.
- Tighten the locknut until the slot on the locknut passes the number of tangs shown in table C-33.
- Bend a tang on the lockwasher into a slot on the locknut to prevent the locknut from loosening.
- Tighten the housed unit mounting bolts.

If using covers:

- Make sure the mating surface of the cover and retaining nuts are clean and dry.
 - Urethane cover: slightly roughen the mating surface of the cover, place a 3 mm – 6 mm ($\frac{1}{8}$ in. – $\frac{1}{4}$ in.) bead of polyurethane adhesive sealant on the roughened surface.
 - Steel cover: place a 3 mm – 6 mm ($\frac{1}{8}$ in. – $\frac{1}{4}$ in.) bead of silicone adhesive sealant on the mating surface of the cover.
- Align the cover mounting holes with the mounting holes on the retaining housing nut (make sure that the grease fitting on the cover is accessible when doing so).
- Apply and tighten the cover mounting hardware.

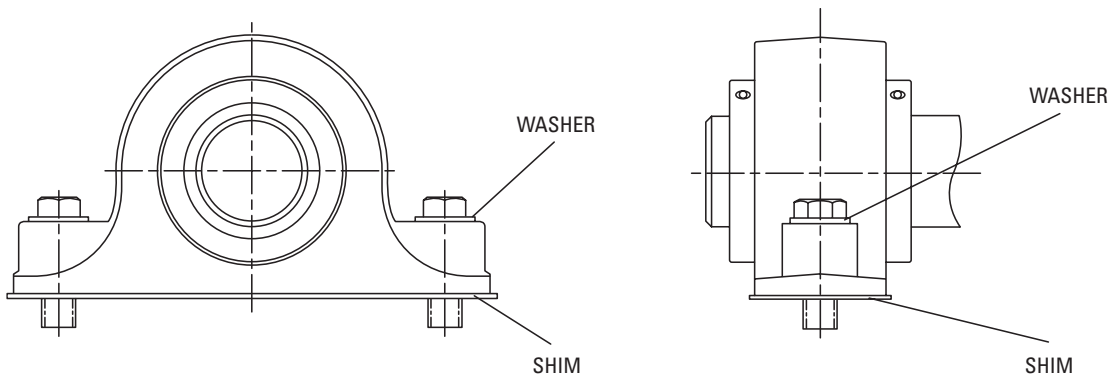

Fig. C-24. Use washers and full shims.

TABLE C-33. NUMBER OF TANGS TO LOCKING

Shaft Dia.	Bearing No.	Number of Tangs
mm in.		
40 1 7/16, 1 1/2	22209	3-4
45 1 11/16, 1 3/4	22210	3-4
50 1 15/16, 2	22211	4-5
55 —	22212	4-5
60 2 3/16, 2 1/4	22213	4-5
65 2 7/16, 2 1/2	22215	5-6
70 2 11/16, 2 3/4	22216	5-6
75 2 15/16, 3	22217	8-9
80 3 3/16, 3 1/4	22218	8-9
85 —	22219	8-9
90 3 7/16, 3 1/2	22220	8-9
100 3 15/16, 4	22222	10-11
110 4 3/16, 4 1/4	22224	10-11
115 4 7/16, 4 1/2	22226	10-11
125 4 15/16, 5	22228	10-11

LUBRICATION

This information is to aid in the proper lubrication of Timken spherical roller bearing solid-block housed units for the majority of applications.

Housed units have been factory-prelubricated with an NLGI No. 2 lithium-complex, extreme-pressure synthetic grease that combines the benefits of wide operating temperatures and broad compatibility with varied materials. This grease offers excellent thermal stability through temperatures ranging from -40° C to 177° C (-40° F to 350° F). Housed units should be relubricated with this grease or one that is compatible and made for roller bearings. It is vital that the greases used are compatible. Please consult with your Timken engineer for the grease specifications if the use of a grease other than the grease mentioned above is needed.

Normal service is considered as operation in a clean, dry environment at temperatures between -34° C to +82° C (-30° F to +180° F). If service is beyond normal conditions due to speed, temperature or exposure to moisture, dirt or corrosive chemicals, periodic relubrication may be necessary. For extreme conditions or conditions in which special chemicals are used, consult with your Timken engineer.

After extended storage or periods when the housed unit is not in operation, fresh grease should be added.

It's important to have the right amount of lubrication, because it affects the housed unit bearing operating temperature as well. An inadequate amount of grease could lead to higher operating temperatures due to inadequate lubrication film thickness. Excessive grease will lead to higher operating temperatures due to grease churning, which can cause bearing overheating. It is best to observe the bearing and its temperature and adjust the lubrication as needed. If necessary, use the purge valve or seals that purge to reduce the amount of grease.

NOTE

Please check with the manufacturer of your grease delivery system for specific information.

RELUBRICATION

Adequate lubrication is an essential element to the housed unit bearing life. Use table C-34 as a suggested initial point of reference. Relubrication frequency and quantity intervals are best determined through experience for each application based on types of service, which may differ from the suggestions in the table.

When the housed unit is not in operation for an extended period of time, grease should be added to prevent corrosion.

Table C-34 shows general lubrication suggested starting points only. Please read the entire installation instructions prior to using these tables. Applications should be regularly reviewed and lubrication amounts and intervals modified as needed to ensure the best results.

WARNING

Failure to observe the following warnings could create a risk of death or serious injury.

Proper maintenance and handling practices are critical. Always follow installation instructions and maintain proper lubrication.

Overheated bearings can ignite explosive atmospheres. Special care must be taken to properly select, install, maintain, and lubricate housed unit bearings that are used in or near atmospheres that may contain explosive levels of combustible gases or accumulations of dust such as from grain, coal, or other combustible materials. Consult your equipment designer or supplier for installation and maintenance instructions.

TABLE C-34. RELUBRICATION INTERVALS

Shaft Dia.	Bearing No.	Initial Weight	Relubrication Weight	Relubrication Interval (Hours of Service based on RPM and Temperature deg. F)											
				100 RPM		250 RPM		500 RPM		1000 RPM		2000 RPM		3000 RPM	
				<160°	>160°	<160°	>160°	<160°	>160°	<160°	>160°	<160°	>160°	<160°	>160°
mm in.		g oz.	g oz.												
40 1 7/16, 1 1/2	22209	19.8 0.7	5.7 0.2	2000	1000	1200	600	800	400	320	160	160	80	80	40
45 1 11/16, 1 3/4	22210	22.7 0.8	5.7 0.7	1600	800	1000	500	640	320	240	120	120	60	60	30
50 1 15/16, 2	22211	28.4 1.0	8.5 0.3	1200	600	800	400	440	220	160	80	100	50	60	30
55 —	22212	34.0 1.2	8.5 0.3	1150	580	750	380	400	200	140	70	90	50	50	20
60 2 3/16, 2 1/4	22213	39.7 1.4	11.3 0.4	1120	560	720	360	360	180	120	60	80	40	40	20
65 2 7/16, 2 1/2	22215	76.5 2.7	19.8 0.7	1040	520	680	340	340	170	100	50	60	30		
70 2 11/16, 2 3/4	22216	76.5 2.7	19.8 0.7	1040	520	680	340	340	170	10	50	60	30		
75 2 15/16, 3	22217	96.4 3.4	25.5 0.9	1000	500	640	320	320	160	100	50	60	30		
80 3 3/16, 3 1/4	22218	104.9 3.7	25.5 0.9	960	480	600	300	300	150	80	40	40	20		
85 —	22219	104.9 3.7	25.5 0.9	960	480	600	300	300	150	80	40	40	20		
90 3 7/16, 3 1/2	22220	184.3 6.5	45.4 1.6	840	420	520	260	240	120	60	30				
100 3 15/16, 4	22222	209.8 7.4	53.9 1.9	680	340	440	220	200	100	60	30				
110 4 3/16, 4 1/4	22224	260.8 9.2	68.0 2.4	640	320	400	200	180	90	50	25				
115 4 7/16, 4 1/2	22226	340.2 12.0	85.0 3.0	600	300	360	180	160	80	40	20				
125 4 15/16, 5	22228	396.9 14.0	99.2 3.5	520	260	340	170	140	75						

DISCLAIMER: Every reasonable effort has been made to ensure the accuracy of the information in this writing, but no liability is accepted for errors, omissions or for any other reason.

HOW TO CONVERT A SOLID-BLOCK HOUSED UNIT FROM FIXED TO EXPANSION (FLOATING)

Flange Cartridge and Flange Block

- Make a reference mark on the housing and retaining nut.
- Loosen the Teflon-tipped set screw that locks the retaining nut in place.
- Loosen the retaining nut by tapping it with a hammer and punch, rotating the retaining nut counterclockwise one complete revolution.
- Tighten the Teflon-tipped set screw.

NOTE

When converting a solid-block housed unit bearing from fixed to expansion, it is imperative that the unit that is going to be converted is correctly oriented. Since the insert in a steel housed unit flange bearing is held against either a shoulder or snap ring opposite the housing retaining nut, a flange bearing that has been converted to expansion can only float in the direction of the retaining nut. Based on this, the retaining nut must be on the side of the housing opposite the fixed bearing.

Pillow Block

- Decide the amount and direction of expansion that's needed. If unidirectional expansion is required, follow the directions outlined above for flange bearings on the nut that is on the side you want the expansion.
- If multi-directional expansion is required, follow the directions above for both nuts on flange housed units.

HOW TO CONVERT A SOLID-BLOCK HOUSED UNIT FROM EXPANSION (FLOATING) TO FIXED

Flange Cartridge and Flange Block

- Loosen the Teflon-tipped set screw that locks the retaining nut in place.
- Tighten the retaining nut by tapping it with a hammer and punch, rotating the retaining nut clockwise until tight. It is not possible to overtighten the retaining nut.
- Tighten the Teflon-tipped set screw.

Pillow Block

- Follow the directions above for flange bearings on both nuts on either side of the housing.

NOTE

When converting a solid-block housed unit from expansion to fixed on a mounted bearing, the locking-collar set screws must be released to allow the insert to move both in the housing and on the shaft.

***SPHERICAL ROLLER BEARING
SOLID-BLOCK HOUSED UNITS
PRODUCT DATA TABLES***

When your equipment faces harsh environments, you need spherical roller bearing solid-block housed units rugged enough to withstand tough conditions and deliver exceptional performance. You gain both with Timken® spherical roller bearing solid-block housed units.

Nomenclatures	C-54
Seal and Cover Options	C-59
V-Lock® Series (double taper lock)	C-73
CL Series (concentric [set screw] lock)	C-99
EC Series (eccentric lock)	C-129
TA/DV Series (tapered adapter lock)	C-153
Take-Up Frames	C-169

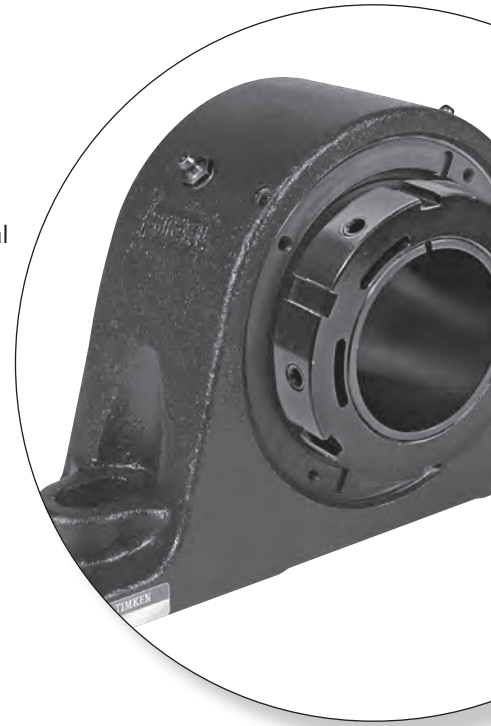

SPHERICAL ROLLER BEARING SOLID-BLOCK HOUSED UNIT NOMENCLATURE

QM P 13 J 207 S E M

LOCKING STYLE
 QM – eccentric lock
 QA – concentric (set screw) lock, single-collar
 QAA – concentric (set screw) lock, double-collar
 QV – V-Lock®, single-nut
 QVV – V-Lock, double-nut
 DV – tapered adapter lock (heavy-duty block)
 TA – tapered adapter lock (extreme-duty block)

HOUSING STYLE

P – Type E dimension two-bolt pillow block	PX – 5000 series four-bolt pillow block
PL – two-bolt pillow block, S2000 style	F – square flange block
PA – SAF-style two-bolt pillow block	FB – square flange block
PN – SN-style two-bolt pillow block	FL – square flange block
SN – SN-style two-bolt pillow block	FX – 5000 series flange block
PKT – 9000 series two-bolt pillow block	FY – round flange block
PXT – 5000 series two-bolt pillow block	FK – 9000 series flange block
PR – Type E dimension four-bolt pillow block	C – piloted flange cartridge
PF – four-bolt pillow block, S2000 style	CW – piloted flange cartridge
PH – SAF-style four-bolt pillow block	FC – piloted flange cartridge
PG – SN-style four-bolt pillow block	MC – cartridge block
PK – 9000 series four-bolt pillow block	TU – take-up block

BEARING INSERT BORE SERIES
 222XX (i.e., 13 = 22213)
 232XX (for size 30 and 34 bearing only)

BEARING INSERT LOCKING TYPE
 J – EC series
 A and AA – CL series
 V – V-Lock series
 K – TA/DV series

SHAFT DIAMETER
 In inch (i.e., 207 = 2 7/16 in.) and metric (i.e., 050 = 50 mm) sizes

CAST-STEEL HOUSING

EXPANSION OR NON-EXPANSION
 BLANK (No letter) – Non-expansion (fixed)
 E – Expansion (floating)

SEAL TYPE

M – M seal (triple-lip nitrile rubber)	C – C seal (double-lip Viton)	DuPont™ is a trademark of E.I. du Pont de Nemours and Company. Teflon® is a registered trademark of E.I. du Pont de Nemours and Company. Viton® is a registered trademark of E.I. du Pont de Nemours and Company.
N – N seal (triple-lip DuPont™ Viton®)	T – T seal (DuPont™ Teflon® labyrinth)	
O – O seal (triple-lip urethane)	YDR – flange cartridge backing plate with DR triple-lip seal	
B – B seal (double-lip nitrile rubber)		

STEEL COVER NOMENCLATURE

CJ **18** **T** **085** **S**

Open-End Steel Cover

LOCKING STYLE

CA – concentric lock
 CJ – eccentric lock
 CV – V-Lock
 CK – tapered adapter lock

BEARING INSERT SERIES

222XX (i.e., 13 = 22213)
 232XX (for size 30 and 34 bearing only)

SEAL TYPE

T seal only

SHAFT SIZE

In inch (i.e., 207 = 2 7/16 in.) and metric (i.e., 050 = 50 mm) sizes

STEEL COVER

CS **18** **STEEL**

Closed-End Steel Cover

BEARING INSERT SERIES

222XX (i.e., 13 = 22213)
 232XX (for size 30 and 34 bearing only)

STEEL COVER

URETHANE COVER NOMENCLATURE

Open-End Cover with DR Seal

CJ **DR** **207**

LOCKING STYLE

CA – concentric lock
 CJ – eccentric lock
 CK – tapered adapter lock

TRIPLE-LIP SECONDARY SEAL

SHAFT SIZE

In inch (i.e., 207 = 2 7/16 in.) and metric (i.e., 050 = 50 mm) sizes

Open-End Cover with VR Seal

CJ **VR** **13**

LOCKING STYLE

CV – V-Lock
 CA – concentric lock
 CJ – eccentric lock
 CK – tapered adapter lock

SEAL TYPE

VR ring

BEARING INSERT SERIES

222XX (i.e., 13 = 22213)
 232XX (for size 30 and 34 bearing only)

V-Lock® Open-End Cover with DR Seal

CV **DR** **13** – **085**

LOCKING STYLE

CV – V-Lock

TRIPLE-LIP SECONDARY SEAL

BEARING INSERT SERIES

222XX (i.e., 13 = 22213)
 232XX (for size 30 and 34 bearing only)

SHAFT SIZE

In inch (i.e., 207 = 2 7/16 in.) and metric (i.e., 050 = 50 mm) sizes

Closed-End Cover

CS **13**

BEARING INSERT SERIES

222XX (i.e., 13 = 22213)
 232XX (for size 30 and 34 bearing only)

BACKING PLATE NOMENCLATURE

UFP **207**

Backing Plate (Only Available for CA and CJ Series Bearings)

SQUARE FLANGE BLOCK WITH VR SEAL

SHAFT SIZE
In inch (i.e., 207 = 2 7/16 in.) and metric (i.e., 050 = 50 mm) sizes

HSY **085**

Backing Plate (Only Available for CA and CJ Series Bearings)

ROUND PILOTED FLANGE CARTRIDGE WITH DR SEAL

SHAFT SIZE
In inch (i.e., 207 = 2 7/16 in.) and metric (i.e., 050 = 50 mm) sizes

ORDERING SOLID-BLOCK HOUSED UNITS

Every solid-block housed unit is made of cast steel for greater strength (compared to cast iron). All bearings feature a double-row, spherical roller bearing design for a high load-carrying capacity, misalignment tolerance and reduced friction.

Starting with these standard design advantages, you can choose from a wide range of sizes, locking styles, seal options and housing styles suited precisely for your application.

There are many ways to determine the correct solid-block housed unit part number for ordering purposes:

- Once you determine the best locking style, housing and seal options for your application, you can easily find the correct part number in the tables included in the following sections.
- If you are ordering a replacement for an existing housed unit, locate the part number for that housed unit on the housing tag.
- If none of the above apply, or if you have additional questions or concerns about ordering the correct housed unit, contact your Timken engineer.

SEAL AND COVER OPTIONS

PRIMARY SEALS

Primary seals are installed between the inner ring of the bearing and the housing. They are held securely in place by the external housing nut. Primary seals can be contacting or non-contacting, purging or non-purging and are available in several material compounds for a variety of applications.

TRIPLE-LIP SEALS – CONTACTING, SELF-PURGING, LOW TO MODERATE SPEEDS⁽¹⁾

Timken offers three kinds of medium-contact triple-lip seals. Choose from seals made of nitrile synthetic rubber (acrylonitrile butadiene), DuPont™ Viton® fluoroelastomer or urethane.

- **M Seal** – This seal, made of nitrile rubber, offers superior sealing in moist and dirty applications. It is chemical- and corrosion-resistant and provides excellent lubrication retention. It also allows excess grease to purge from the bearing cavity.
- **N Seal** – Made of DuPont Viton, this seal provides excellent chemical resistance and can operate at higher temperatures than nitrile rubber.
- **O Seal** – Made of high-strength urethane for superior abrasion resistance.

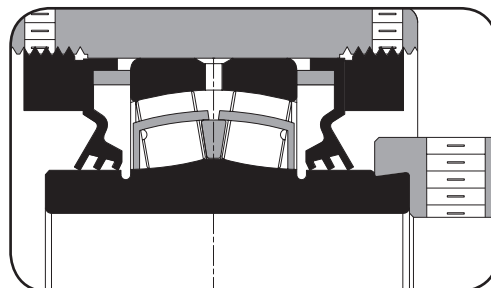

Fig. C-25. Triple-lip seals.

LABYRINTH SEALS – NON-CONTACTING, NON-PURGING, ALL SPEEDS⁽²⁾

Instead of trying to form a seal with a single strong barrier, a labyrinth seal uses a winding passageway to accomplish the same reduction in flow. Not only is seal friction reduced, but so is seal wear.

- **T Seal** – This seal consists of a DuPont™ Teflon® ring pressed onto the inner ring of the bearing that floats between two pieces of formed steel to accommodate misalignment. When using this seal, the housing comes with a vent fitting. Developed for higher-speed applications involving dirty conditions or moisture-affected areas, it is able to operate at higher temperatures and is impervious to most chemicals.

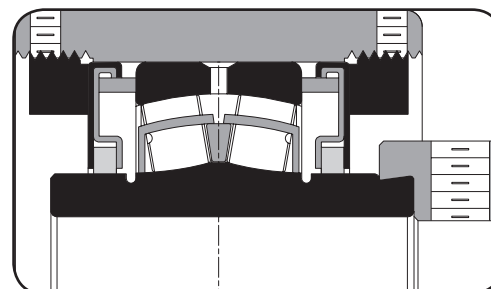

Fig.C-26. T seal.

DOUBLE-LIP SEALS – CONTACTING, NON-PURGING, LOW SPEEDS⁽¹⁾⁽²⁾

These seals incorporate a double-lip seal, a garter spring for maximum contact, and a heavy-duty steel shield that protects the seal from large pieces of debris that could damage the seal itself.

- **B Seal** – Made of nitrile rubber, this seal offers superior protection in applications with oil lubrication and is designed for extreme moisture, fine dust or extremely dirty applications. When using this seal, the housing comes with a vent fitting.
- **C Seal** – Made of DuPont Viton, this seal provides excellent chemical and abrasion resistance and can operate at higher temperatures than nitrile rubber. When using this seal, the housing comes with a vent fitting.

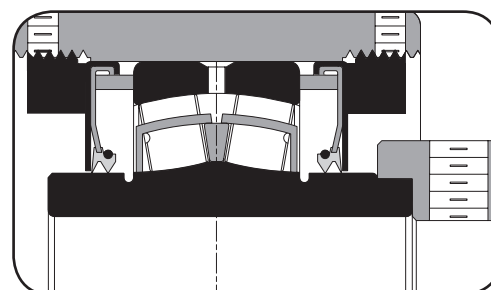

Fig. C-27. Double-lip seals.

⁽¹⁾Temperature limit -40° C to 121° C (-40° F to 250° F) continuous, 149° C (300° F) intermittent. Constant seal-lip pressure on the inner ring results in higher operating temperatures of the complete unit. (See pages C-25 and C-26).

⁽²⁾Relief valve is standard.

DuPont™ is a trademark of E.I. du Pont de Nemours and Company. Teflon® is a registered trademark of E.I. du Pont de Nemours and Company. Viton® is a registered trademark of E.I. du Pont de Nemours and Company.

SECONDARY SEALS

In many circumstances, bearings become damaged in housed units due to premature primary seal wear. This is usually the result of harsh operating environments or lubrication issues. Timken offers secondary sealing options that provide an additional barrier to protect the primary seal. These economical secondary seals and covers are easily outfitted on virtually all solid-block housed units.

STEEL COVERS

Labyrinth Seals – Non-Contacting, Non-Purging, All Speeds

A labyrinth seal uses a winding passageway to accomplish a reduction in flow instead of trying to form a seal with a single strong barrier. Seal friction and wear is reduced.

- **T Seal** – This seal, which is used in the open-end steel covers, consists of a DuPont Teflon ring pressed onto the shaft that floats between two pieces of formed steel to accommodate misalignment. Developed for higher-speed applications involving dirty conditions or moisture-affected areas, it is able to operate at higher temperatures and is impervious to most chemicals, while avoiding shaft damage.

URETHANE COVERS

DR Triple-Lip Secondary Seal – low speeds

The DR seal is the standard triple-lip seal adapted for use on the open-end covers and piloted flange cartridge backing plates (HSY). This seal can move within the cover or backing plate opening to accommodate misalignment while maintaining full contact to the shaft for positive sealing.

VR V-Ring Secondary Seal – high speeds

The VR seal, made of nitrile rubber, rides on the shaft and seals against the open-end covers and flange block backing plates (UFP).

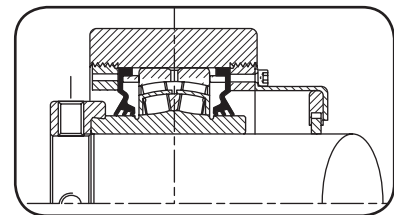

Fig. C-28. Open-end steel cover with T seal.

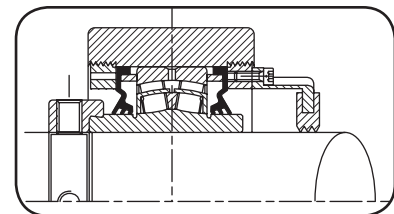

Fig. C-29. Open-end urethane cover with DR seal.

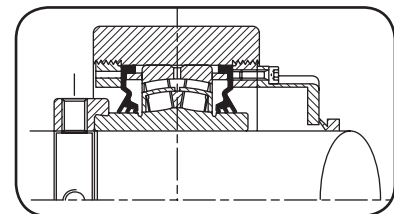

Fig. C-30. Open-end urethane cover with VR seal.

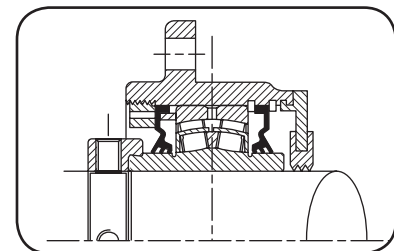

Fig. C-31. HSY backing plate with DR seal.

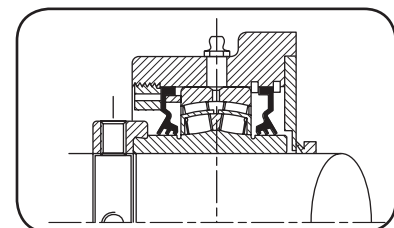

Fig. C-32. UFP backing plate with VR seal.

STEEL AUXILIARY COVERS

Steel auxiliary covers bolt directly onto spherical roller bearing solid-block housed units. A DuPont Teflon labyrinth seal on the open-ended covers guards against shaft damage and gives protection at high running speeds. Made from steel to withstand the toughest applications, the covers are black-oxide treated for improved corrosion protection.

These covers are available in both open-ended and closed-ended designs for standard and custom configurations of Timken spherical roller bearing solid-block housed units.

Closed-End Covers (CS)

These bolt-on covers are designed to be virtually indestructible and extremely convenient. They are made from structural steel or urethane and are easy to install. The cover completely seals the bearing, preventing contamination from reaching the primary seal. Every cover is outfitted with a grease fitting to fill the cover cavity for an added barrier against contamination.



Fig. C-33. Closed-end covers.

Open-End Covers (CJ/CK/CV)

These bolt-on covers are made from structural steel or urethane for repeated and continuous use. The covers are used with either a DuPont Teflon (T seal), triple-lip seal (DR) or a V-ring seal (VR) to help prevent contamination from reaching the primary seal. Every cover is outfitted with a grease fitting to fill the cover cavity for an added barrier against contamination.



Fig. C-34. Open-end covers.

PILOTED FLANGE CARTRIDGE BACKING PLATES (HSY)

The HSY backing plate is designed to work in conjunction with the piloted flange cartridge housed units. Made of structural urethane, these plates are fitted to the back side of the pilot for extra protection. The HSY plate comes supplied with a triple-lip seal (DR) or a contamination collar (optional) to form an additional barrier against contamination for the most demanding applications.



Fig. C-35. Piloted flange cartridge backing plates.

FLANGE BLOCK BACKING PLATES (UFP)

These backing plates are made from structural urethane and are uniquely designed to work with our flange block housed units. Made to fit flush against the back of the housing, these plates create a labyrinth over the inner ring for additional contamination protection. The UFP plate, when used with an optional V-ring seal (VR), provides an extra barrier against extreme contamination.



Fig. C-36. Flange block backing plates.

SPHERICAL ROLLER BEARING SOLID-BLOCK HOUSED UNITS

SEAL AND COVER OPTIONS • STEEL COVER DIMENSIONS

STEEL COVER DIMENSIONS

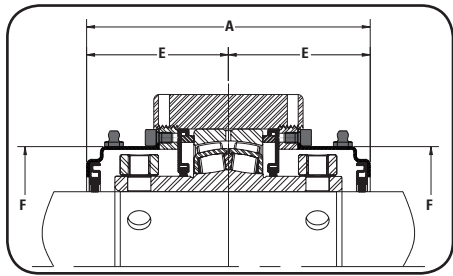

Fig. C-37. Double open-end cover.⁽¹⁾

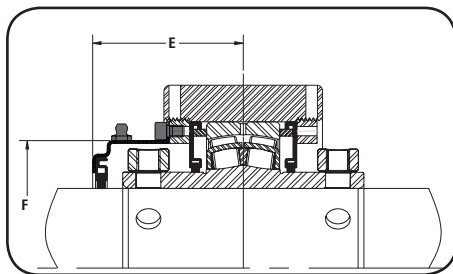

Fig. C-38. Single open-end cover.

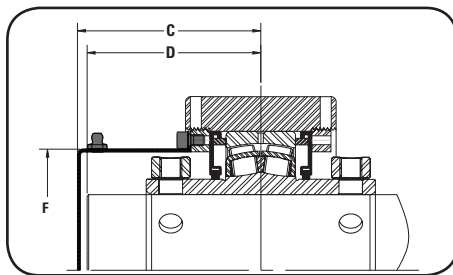

Fig. C-39. Single closed-end cover.

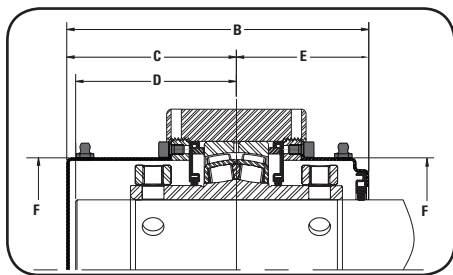

Fig. C-40. Single closed-end cover and single open-end cover.⁽¹⁾

TABLE C-35. V-LOCK® SERIES—STRAIGHT BORE EQUIVALENTS

Cover Part No.	Shaft Dia.	Bearing No.	Steel Cover Dimensions					
			A	B	C	D	E	F
			mm in.	mm in.	mm in.	mm in.	mm in.	mm in.
CS11STEEL	CLOSED	22211						
CV11T115S	1 15/16 in.		128.5	143.3	79.2	75.2	64.3	89.7
CV11T050S	50 mm		5.06	5.64	3.12	2.96	2.53	3.53
CV11T200S	2 in.							
CS12STEEL	CLOSED	22212						
CV12T055S	55 mm		129.0	141.5	77.0	72.9	64.5	98.6
CV12T203S	2 3/16 in.		5.08	5.57	3.03	2.87	2.54	3.88
CV12T204S	2 1/4 in.							
CS14STEEL	CLOSED	22214						
CV14T060S	60 mm		135.4	159.3	91.4	87.4	67.8	103.6
CV14T207S	2 7/16 in.		5.33	6.27	3.60	3.44	2.67	4.08
CV14T208S	2 1/2 in.							
CV14T065S	65 mm							
CS16STEEL	CLOSED	22216						
CV16T211S	2 11/16 in.		150.1	167.6	92.5	88.4	75.2	116.1
CV16T212S	2 3/4 in.		5.91	6.60	3.64	3.48	2.96	4.57
CV16T070S	70 mm							
CV16T215S	2 15/16 in.							
CV16T075S	75 mm							
CV16T300S	3 in.							
CS19STEEL	CLOSED	22219						
CV19T080S	80 mm		167.9	191.0	106.9	102.9	84.1	139.4
CV19T303S	3 3/16 in.		6.61	7.52	4.21	4.05	3.31	5.49
CV19T304S	3 1/4 in.							
CV19T085S	85 mm							
CV19T307S	3 7/16 in.							
CV19T308S	3 1/2 in.							
CV19T090S	90 mm							
CS22STEEL	CLOSED	22222						
CV22T311S	3 11/16 in.		217.7	241.8	133.1	129.0	109.0	180.1
CV22T312S	3 3/4 in.		8.57	9.52	5.24	5.08	4.29	7.09
CV22T100S	100 mm							
CV22T315S	3 15/16 in.							
CV22T400S	4 in.							
CS26STEEL	CLOSED	22226						
CV26T110S	110 mm		219.7	242.8	133.1	129.0	110.0	209.3
CV26T407S	4 7/16 in.		8.65	9.56	5.24	5.08	4.33	8.24
CV26T408S	4 1/2 in.							
CV26T115S	115 mm							
CS28STEEL	CLOSED	22228						
CV28T125S	125 mm		223.5	246.9	135.1	131.1	111.8	209.3
CV28T415S	4 15/16 in.		8.80	9.72	5.32	5.16	4.40	8.24
CV28T500S	5 in.							
CV28T130S	130 mm							

⁽¹⁾Double covers available only on pillow block and take-up style bearings.

SPHERICAL ROLLER BEARING SOLID-BLOCK HOUSED UNITS

SEAL AND COVER OPTIONS • STEEL COVER DIMENSIONS

TABLE C-36. V-LOCK SERIES – TAPERED BORE EQUIVALENTS

Cover Part No.	Shaft Dia.	Bearing No.	Steel Cover Dimensions					
			A	B	C	D	E	F
	mm in.		mm in.	mm in.	mm in.	mm in.	mm in.	mm in.
CS11STEEL	CLOSED	22211	124.2 4.89	139.2 5.48	77.0 3.03	72.9 2.87	62.2 2.45	89.7 3.53
CV11T115S	1 15/16 in.							
CV11T050S	50 mm							
CV11T200S	2 in.							
CS13STEEL	CLOSED	22213	130.3 5.13	154.2 6.07	88.9 3.50	84.8 3.34	65.3 2.57	103.6 4.08
CV13T055S	55 mm							
CV13T203S	2 3/16 in.							
CV13T204S	2 1/4 in.							
CS15STEEL	CLOSED	22215	142.7 5.62	160.3 6.31	88.9 3.50	84.8 3.34	71.4 2.81	116.1 4.57
CV15T060S	60 mm							
CV15T207S	2 7/16 in.							
CV15T208S	2 1/2 in.							
CS17STEEL	CLOSED	22217	133.9 5.27	156.0 6.14	88.9 3.50	84.8 3.34	67.1 2.64	132.1 5.2
CV17T211S	2 11/16 in.							
CV17T212S	2 3/4 in.							
CV17T070S	70 mm							
CV17T215S	2 15/16 in.	22219	170.4 6.71	193.0 7.60	108.0 4.25	103.9 4.09	85.3 3.36	160.3 6.31
CV17T075S	75 mm							
CV17T300S	3 in.							
CS20STEEL	CLOSED							
CV20T080S	80 mm	22220	170.4 6.71	193.0 7.60	108.0 4.25	103.9 4.09	85.3 3.36	160.3 6.31
CV20T303S	3 3/16 in.							
CV20T304S	3 1/4 in.							
CV20T085S	85 mm							
CV20T307S	3 7/16 in.	22222	208.5 8.21	232.9 9.17	128.5 5.06	124.5 4.90	104.4 4.11	180.1 7.09
CV20T308S	3 1/2 in.							
CV20T090S	90 mm							
CS22STEEL	CLOSED							
CV22T311S	3 11/16 in.	22224	213.6 8.41	237.7 9.36	131.1 5.16	127.0 5.00	106.7 4.20	180.1 7.09
CV22T312S	3 3/4 in.							
CV22T100S	100 mm							
CV22T315S	3 15/16 in.							
CV22T400S	4 in.	22226	210.6 8.29	233.9 9.21	128.5 5.06	124.5 4.90	105.4 4.15	209.3 8.24
CS24STEEL	CLOSED							
CV24T110S	110 mm							
CS26STEEL	CLOSED							
CV26T110S	110 mm	22228	214.6 8.45	238.0 9.37	130.6 5.14	126.5 4.98	107.2 4.22	209.3 8.24
CV26T407S	4 7/16 in.							
CV26T408S	4 1/2 in.							
CV26T115S	115 mm							
CS28STEEL	CLOSED	22222	217.7 8.57	241.8 9.52	133.1 5.24	129.0 5.08	109.0 4.29	180.1 7.09
CV28T125S	125 mm							
CV28T415S	4 15/16 in.							
CV28T500S	5 in.							
CV28T130S	130 mm	22226	219.7 8.65	242.8 9.56	133.1 5.24	129.0 5.08	110.0 4.33	209.3 8.24
CS26STEEL	CLOSED							
CA22T110S	110 mm							
CA22T407S	4 7/16 in.							
CA22T408S	4 1/2 in.	22222	217.7 8.57	241.8 9.52	133.1 5.24	129.0 5.08	109.0 4.29	180.1 7.09
CA22T115S	115 mm							
CS26STEEL	CLOSED							
CA26T125S	125 mm							
CA26T415S	4 15/16 in.	22226	219.7 8.65	242.8 9.56	133.1 5.24	129.0 5.08	110.0 4.33	209.3 8.24
CA26T500S	5 in.							
CA26T130S	130 mm							

TABLE C-37. CL SERIES – SINGLE AND DOUBLE SET SCREW LOCKS

Cover Part No.	Shaft Dia.	Bearing No.	Steel Cover Dimensions					
			A	B	C	D	E	F
	mm in.		mm in.	mm in.	mm in.	mm in.	mm in.	mm in.
CS08STEEL	CLOSED	22208	115.6 4.55	127.8 5.03	69.9 2.75	65.8 2.59	57.9 2.28	69.6 2.74
CA08T035S	35 mm							
CA08T107S	1 7/16 in.							
CA08T108S	1 1/2 in.							
CS09STEEL	CLOSED	22209	121.7 4.79	130.8 5.15	69.9 2.75	65.8 2.59	61.0 2.40	74.7 2.94
CA09T040S	40 mm							
CA09T111S	1 11/16 in.							
CA09T112S	1 3/4 in.							
CS10STEEL	CLOSED	22210	122.7 4.83	132.8 5.23	73.2 2.88	69.1 2.72	61.5 2.42	79.8 3.14
CA10T115S	1 15/16 in.							
CA10T050S	50 mm							
CA10T200S	2 in.							
CS11STEEL	CLOSED	22211	128.5 5.06	143.3 5.64	79.2 3.12	75.2 2.96	64.3 2.53	89.7 3.53
CA11T055S	55 mm							
CA11T203S	2 3/16 in.							
CA11T204S	2 1/4 in.							
CS13STEEL	CLOSED	22213	135.4 5.33	159.3 6.27	91.4 3.60	87.4 3.44	67.8 2.67	103.6 4.08
CA13T060S	60 mm							
CA13T207S	2 7/16 in.							
CA13T208S	2 1/2 in.							
CS15STEEL	CLOSED	22215	148.1 5.83	165.6 6.52	91.4 3.60	87.4 3.44	74.2 2.92	116.1 4.57
CA15T211S	2 11/16 in.							
CA15T212S	2 3/4 in.							
CA15T070S	70 mm							
CA15T215S	2 15/16 in.	22218	164.8 6.49	188.0 7.40	105.7 4.16	101.6 4.00	82.6 3.25	139.4 5.49
CA15T075S	75 mm							
CA15T300S	3 in.							
CS18STEEL	CLOSED							
CA18T080S	80 mm	22220	179.6 7.07	202.2 7.96	112.5 4.43	108.5 4.27	89.9 3.54	160.3 6.31
CA18T303S	3 3/16 in.							
CA18T304S	3 1/4 in.							
CA18T085S	85 mm							
CA18T307S	3 7/16 in.	22222	217.7 8.57	241.8 9.52	133.1 5.24	129.0 5.08	109.0 4.29	180.1 7.09
CA18T308S	3 1/2 in.							
CA18T090S	90 mm							
CS20STEEL	CLOSED							
CA20T311S	3 11/16 in.	22226	219.7 8.65	242.8 9.56	133.1 5.24	129.0 5.08	110.0 4.33	209.3 8.24
CA20T312S	3 3/4 in.							
CA20T100S	100 mm							
CA20T315S	3 15/16 in.							
CA20T400S	4 in.	22222	217.7 8.57	241.8 9.52	133.1 5.24	129.0 5.08	109.0 4.29	180.1 7.09
CS22STEEL	CLOSED							
CA22T110S	110 mm							
CA22T407S	4 7/16 in.							
CA22T408S	4 1/2 in.	22226	219.7 8.65	242.8 9.56	133.1 5.24	129.0 5.08	110.0 4.33	209.3 8.24
CA22T115S	115 mm							
CS26STEEL	CLOSED							
CA26T125S	125 mm							
CA26T415S	4 15/16 in.	22226	219.7 8.65	242.8 9.56	133.1 5.24	129.0 5.08	110.0 4.33	209.3 8.24
CA26T500S	5 in.							
CA26T130S	130 mm							

SPHERICAL ROLLER BEARING SOLID-BLOCK HOUSED UNITS

SEAL AND COVER OPTIONS • STEEL COVER DIMENSIONS

TABLE C-38. EC SERIES—ECCENTRIC LOCK

Cover Part No.	Shaft Dia.	Bearing No.	Steel Cover Dimensions					
			A	B	C	D	E	F
	mm in.		mm in.	mm in.	mm in.	mm in.	mm in.	mm in.
CS08STEEL	CLOSED	22208	115.6 4.55	127.8 5.03	69.9 2.75	65.8 2.59	57.9 2.28	69.6 2.74
CJ08T035S	35 mm							
CJ08T107S	1 7/16 in.							
CJ08T108S	1 1/2 in.	22209	121.7 4.79	130.8 5.15	69.9 2.75	65.8 2.59	61.0 2.40	74.7 2.94
CS09STEEL	Closed							
CJ09T040S	40 mm							
CJ09T111S	1 11/16 in.	22210	122.7 4.83	132.8 5.23	73.2 2.88	69.1 2.72	61.5 2.42	79.8 3.14
CJ09T112S	1 3/4 in.							
CJ09T045S	45 mm							
CS10STEEL	CLOSED	22211	128.5 5.06	143.3 5.64	79.2 3.12	75.2 2.96	64.3 2.53	89.7 3.53
CJ10T115S	1 15/16 in.							
CJ10T050S	50 mm							
CJ10T200S	2 in.	22213	135.4 5.33	159.3 6.27	91.4 3.60	87.4 3.44	67.8 2.67	103.6 4.08
CS11STEEL	CLOSED							
CJ11T055S	55 mm							
CJ11T203S	2 3/16 in.	22215	148.1 5.83	165.6 6.52	91.4 3.60	87.4 3.44	74.2 2.92	116.1 4.57
CJ11T204S	2 1/4 in.							
CS13STEEL	CLOSED							
CJ13T060S	60 mm	22218	164.8 6.49	188.0 7.40	105.7 4.16	101.6 4.00	82.6 3.25	139.4 5.49
CJ13T207S	2 7/16 in.							
CJ13T208S	2 1/2 in.							
CJ13T065S	65 mm	22222	122.7 4.83	132.8 5.23	73.2 2.88	69.1 2.72	61.5 2.42	79.8 3.14
CS15STEEL	CLOSED							
CJ15T211S	2 11/16 in.							
CJ15T212S	2 3/4 in.	22226	148.1 5.83	165.6 6.52	91.4 3.60	87.4 3.44	74.2 2.92	116.1 4.57
CJ15T070S	70 mm							
CJ15T215S	2 15/16 in.							
CJ15T075S	75 mm	22228	164.8 6.49	188.0 7.40	105.7 4.16	101.6 4.00	82.6 3.25	139.4 5.49
CJ15T300S	3 in.							
CS18STEEL	CLOSED							
CJ18T080S	80 mm	22230	164.8 6.49	188.0 7.40	105.7 4.16	101.6 4.00	82.6 3.25	139.4 5.49
CJ18T303S	3 3/16 in.							
CJ18T304S	3 1/4 in.							
CJ18T085S	85 mm	22234	164.8 6.49	188.0 7.40	105.7 4.16	101.6 4.00	82.6 3.25	139.4 5.49
CJ18T307S	3 7/16 in.							
CJ18T308S	3 1/2 in.							
CJ18T090S	90 mm	22236	164.8 6.49	188.0 7.40	105.7 4.16	101.6 4.00	82.6 3.25	139.4 5.49
CS20STEEL	CLOSED							
CJ20T311S	3 11/16 in.							
CJ20T312S	3 3/4 in.	22220	179.6 7.07	202.2 7.96	112.5 4.43	108.5 4.27	89.9 3.54	160.3 6.31
CJ20T100S	100 mm							
CJ20T315S	3 15/16 in.							
CJ20T400S	4 in.	22222	217.7 8.57	241.8 9.52	133.1 5.24	129.0 5.08	109.0 4.29	180.1 7.09
CS22STEEL	CLOSED							
CJ22T110S	110 mm							
CJ22T407S	4 7/16 in.	22226	219.7 8.65	242.8 9.56	133.1 5.24	129.0 5.08	110.0 4.33	209.3 8.24
CJ22T408S	4 1/2 in.							
CJ22T115S	115 mm							
CS26STEEL	CLOSED	22226	219.7 8.65	242.8 9.56	133.1 5.24	129.0 5.08	110.0 4.33	209.3 8.24
CJ26T125S	125 mm							
CJ26T415S	4 15/16 in.							
CJ26T500S	5 in.	23230	270.3 10.64	283.2 11.15	148.1 5.83	144.0 5.67	135.1 5.32	239.5 9.43
CJ26T130S	130 mm							
CS30STEEL	CLOSED							
CJ30T507S	5 7/16 in.	23234	300.5 11.83	305.3 12.02	155.2 6.11	151.1 5.95	150.1 5.91	279.4 11.00
CJ30T508S	5 1/2 in.							
CJ30T140S	140 mm							
CJ30T515S	5 15/16 in.	23234	300.5 11.83	305.3 12.02	155.2 6.11	151.1 5.95	150.1 5.91	279.4 11.00
CJ30T600S	6 in.							
CJ30T150S	150 mm							
CS34STEEL	CLOSED	23234	300.5 11.83	305.3 12.02	155.2 6.11	151.1 5.95	150.1 5.91	279.4 11.00
CJ34T607S	6 7/16 in.							
CJ34T608S	6 1/2 in.							
CJ34T170S	170 mm	23234	300.5 11.83	305.3 12.02	155.2 6.11	151.1 5.95	150.1 5.91	279.4 11.00
CJ34T615S	6 15/16 in.							
CJ34T700S	7 in.							
CJ34T180S	180 mm							

Cover Part No.	Shaft Dia.	Bearing No.	Steel Cover Dimensions					
			A	B	C	D	E	F
	mm in.		mm in.	mm in.	mm in.	mm in.	mm in.	mm in.
CS20STEEL	CLOSED	22220	179.6 7.07	202.2 7.96	112.5 4.43	108.5 4.27	89.9 3.54	160.3 6.31
CJ20T311S	3 11/16 in.							
CJ20T312S	3 3/4 in.							
CJ20T100S	100 mm	22222	217.7 8.57	241.8 9.52	133.1 5.24	129.0 5.08	109.0 4.29	180.1 7.09
CJ20T315S	3 15/16 in.							
CJ20T400S	4 in.							
CS22STEEL	CLOSED	22226	219.7 8.65	242.8 9.56	133.1 5.24	129.0 5.08	110.0 4.33	209.3 8.24
CJ22T110S	110 mm							
CJ22T407S	4 7/16 in.							
CJ22T408S	4 1/2 in.	22226	219.7 8.65	242.8 9.56	133.1 5.24	129.0 5.08	110.0 4.33	209.3 8.24
CJ22T115S	115 mm							
CS26STEEL	CLOSED							
CJ26T125S	125 mm	23230	270.3 10.64	283.2 11.15	148.1 5.83	144.0 5.67	135.1 5.32	239.5 9.43
CJ26T415S	4 15/16 in.							
CJ26T500S	5 in.							
CJ26T130S	130 mm	23234	300.5 11.83	305.3 12.02	155.2 6.11	151.1 5.95	150.1 5.91	279.4 11.00
CS30STEEL	CLOSED							
CJ30T507S	5 7/16 in.							
CJ30T508S	5 1/2 in.	23234	300.5 11.83	305.3 12.02	155.2 6.11	151.1 5.95	150.1 5.91	279.4 11.00
CJ30T140S	140 mm							
CJ30T515S	5 15/16 in.							
CJ30T600S	6 in.	23234	300.5 11.83	305.3 12.02	155.2 6.11	151.1 5.95	150.1 5.91	279.4 11.00
CJ30T150S	150 mm							
CS34STEEL	CLOSED							
CJ34T607S	6 7/16 in.	23234	300.5 11.83	305.3 12.02	155.2 6.11	151.1 5.95	150.1 5.91	279.4 11.00
CJ34T608S	6 1/2 in.							
CJ34T170S	170 mm							
CJ34T615S	6 15/16 in.	23234	300.5 11.83	305.3 12.02	155.2 6.11	151.1 5.95	150.1 5.91	279.4 11.00
CJ34T700S	7 in.							
CJ34T180S	180 mm							

TABLE C-39. TA/DV SERIES – TAPERED ADAPTER LOCK

Cover Part No.	Shaft Dia.	Bearing No.	Steel Cover Dimensions					
			A	B	C	D	E	F
	mm in.		mm in.	mm in.	mm in.	mm in.	mm in.	mm in.
CS09STEEL	CLOSED	22209						
CK09T107S	1 7/16 in.		118.4	127.5	68.3	64.3	59.2	74.7
CK09T108S	1 1/2 in.		4.66	5.02	2.69	2.53	2.33	2.94
CK09T040S	40 mm							
CS10STEEL	CLOSED	22210						
CK10T111S	1 1/16 in.		118.4	130.0	70.9	66.8	59.2	79.8
CK10T112S	1 3/4 in.		4.66	5.12	2.79	2.63	2.33	3.14
CK10T045S	45 mm							
CS11STEEL	CLOSED	22211						
CK11T115S	1 15/16 in.		124.2	139.2	77.0	72.9	62.2	89.7
CK11T050S	50 mm		4.89	5.48	3.03	2.87	2.45	3.53
CK11T200S	2 in.							
CS12STEEL	CLOSED	22212	123.7	136.4	74.4	70.4	62.0	98.6
CK12T055S	55 mm		4.87	5.37	2.93	2.77	2.44	3.88
CS13STEEL	CLOSED	22213						
CK13T203S	2 3/16 in.		130.3	154.2	88.9	84.8	65.3	103.6
CK13T204S	2 1/4 in.		5.13	6.07	3.50	3.34	2.57	4.08
CK13T060S	60 mm							
CS15STEEL	CLOSED	22215						
CK15T207S	2 7/16 in.		142.7	160.3	88.9	84.8	71.4	116.1
CK15T208S	2 1/2 in.		5.62	6.31	3.50	3.34	2.81	4.57
CK15T065S	65 mm							
CS16STEEL	CLOSED	22216						
CK16T211S	2 1/16 in.		144.8	162.3	89.9	85.9	72.4	116.1
CK16T212S	2 3/4 in.		5.70	6.39	3.54	3.38	2.85	4.57
CK16T070S	70 mm							
CS17STEEL	CLOSED	22217						
CK17T215S	2 15/16 in.		133.9	156.0	88.9	84.8	67.1	132.1
CK17T075S	75 mm		5.27	6.14	3.50	3.34	2.64	5.20
CK17T300S	3 in.							
CS18STEEL	CLOSED	22218						
CK18T080S	80 mm		159.5	182.9	102.9	98.8	79.8	139.4
CK18T303S	3 3/16 in.		6.28	7.20	4.05	3.89	3.14	5.49
CK18T304S	3 1/4 in.							
CS19STEEL	CLOSED	22219	162.6	185.7	104.4	100.3	81.3	139.4
CK19T085S	85 mm		6.40	7.31	4.11	3.95	3.20	5.49
CS20STEEL	CLOSED	22220						
CK20T307S	3 7/16 in.		170.4	193.0	108.0	103.9	85.3	160.3
CK20T308S	3 1/2 in.		6.71	7.60	4.25	4.09	3.36	6.31
CK20T090S	90 mm							
CS22STEEL	CLOSED	22222						
CK22T315S	3 15/16 in.		208.5	232.9	128.5	124.5	104.4	180.1
CK22T400S	4 in.		8.21	9.17	5.06	4.90	4.11	7.09
CK22T100S	100 mm							
CS24STEEL	CLOSED	22224						
CK24T403S	4 3/16 in.		213.6	237.7	131.1	127.0	106.7	180.1
CK24T404S	4 1/4 in.		8.41	9.36	5.16	5.00	4.20	7.09
CK24T110S	110 mm							
CS26STEEL	CLOSED	22226						
CK26T407S	4 7/16 in.		210.6	233.9	128.5	124.5	105.4	209.3
CK26T408S	4 1/2 in.		8.29	9.21	5.06	4.90	4.15	8.24
CK26T115S	115 mm							
CS28STEEL	CLOSED	22228						
CK28T415S	4 15/16 in.		214.6	238.0	130.6	126.5	107.2	209.3
CK28T500S	5 in.		8.45	9.37	5.14	4.98	4.22	8.24
CK28T125S	125 mm							

URETHANE

CLOSED-END COVER DIMENSIONS

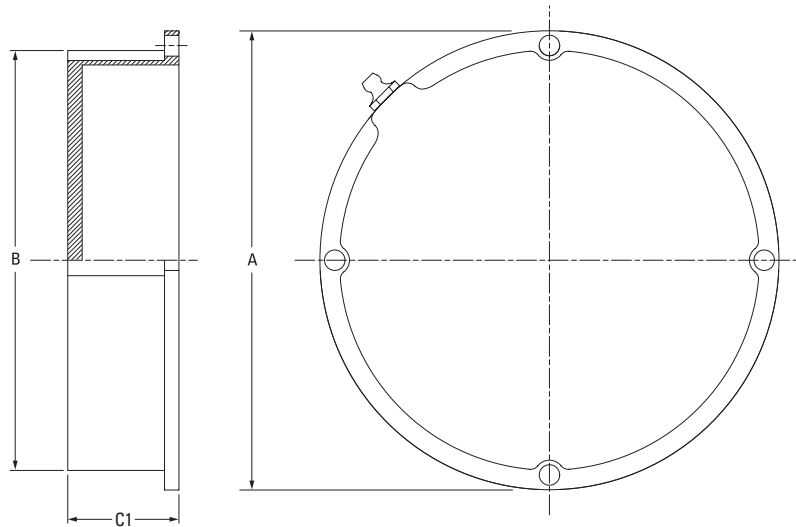

TABLE C-40. CLOSED-END COVER DIMENSIONS

Cover Part No. ⁽¹⁾	A	B	C1 ⁽²⁾
	mm in.	mm in.	mm in.
CS08	97.0 3.82	76.7 3.02	31.8 1.25
CS09	101.8 4.01	81.5 3.21	31.8 1.25
CS10	106.9 4.21	86.6 3.41	31.8 1.25
CS11	117.1 4.61	96.8 3.81	31.8 1.25
CS12V	126.0 4.96	105.7 4.16	31.8 1.25
CS13/CS14V	132.1 5.20	116.1 4.57	31.8 1.08
CS15/CS16V	142.0 5.59	122.9 4.84	33.0 1.30
CS17	160.5 6.32	141.5 5.57	31.0 1.22
CS18/CS19V	168.1 6.62	149.1 5.87	38.9 1.53
CS20	192.0 7.56	174.7 6.88	44.5 1.75
CS22	212.1 8.35	194.8 7.67	52.6 2.07
CS24	212.1 8.35	194.8 7.67	52.6 2.07
CS26/CS28V	241.3 9.50	223.8 8.81	56.9 2.24
CS30	271.5 10.69	254.0 10.00	56.9 2.24
CS34	304.8 12.00	287.3 11.31	56.9 2.24

⁽¹⁾Cover part number, CSXX, is determined by the bearing insert series of unit on which cover will be installed. See nomenclature guide on page C-54 to determine bearing insert series.

⁽²⁾Extended covers available upon request.

OPEN-END COVERS WITH DR SEALS

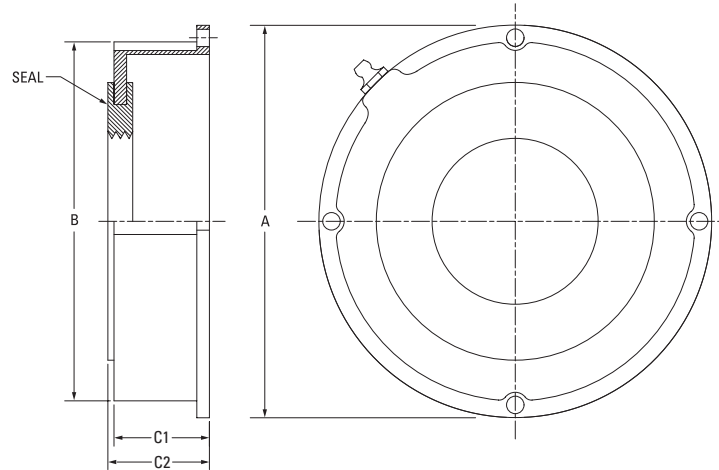

TABLE C-41. V-LOCK SERIES – STRAIGHT BORE EQUIVALENT – OPEN-END COVER WITH DR SEAL – (QV[V]...P, PL, SN, PF, PR, C, CW, F, FL, FY, FX, TU)

Cover Part No.	Shaft Dia.	A	B	C1	C2
	mm in.	mm in.	mm in.	mm in.	mm in.
CVDR115	1 15/16 in.	117.1 4.61	96.8 3.81	31.8 1.25	34.3 1.35
CVDR200	2 in.				
CVDR050MM	50 mm	126.0 4.96	105.7 4.16	31.8 1.25	34.3 1.35
CVDR203	2 3/16 in.				
CVDR204	2 1/4 in.	132.1 5.20	116.1 4.57	27.4 1.08	30.0 1.18
CVDR055MM	55 mm				
CVDR060MM	60 mm	142.0 5.59	122.9 4.84	33.0 1.30	35.6 1.40
CVDR207	2 7/16 in.				
CVDR208	2 1/2 in.	168.1 6.62	149.1 5.87	38.9 1.53	41.4 1.63
CVDR065MM	65 mm				
CVDR211	2 11/16 in.	212.1 8.35	194.8 7.67	52.6 2.07	55.1 2.17
CVDR212	2 3/4 in.				
CVDR070MM	70 mm	241.3 9.50	223.8 8.81	56.9 2.24	59.4 2.34
CVDR215	2 15/16 in.				
CVDR300	3 in.	241.3 9.50	223.8 8.81	56.9 2.24	59.4 2.34
CVDR075MM	75 mm				
CVDR303	3 3/16 in.	212.1 8.35	194.8 7.67	52.6 2.07	55.1 2.17
CVDR304	3 1/4 in.				
CVDR080MM	80 mm	241.3 9.50	223.8 8.81	56.9 2.24	59.4 2.34
CVDR085MM	85 mm				
CVDR307	3 7/16 in.	241.3 9.50	223.8 8.81	56.9 2.24	59.4 2.34
CVDR308	3 1/2 in.				
CVDR090MM	90 mm	241.3 9.50	223.8 8.81	56.9 2.24	59.4 2.34
CVDR311	3 11/16 in.				
CVDR312	3 3/4 in.	241.3 9.50	223.8 8.81	56.9 2.24	59.4 2.34
CVDR100MM	100 mm				
CVDR315	3 15/16 in.	241.3 9.50	223.8 8.81	56.9 2.24	59.4 2.34
CVDR400	4 in.				
CVDR110MM	110 mm	241.3 9.50	223.8 8.81	56.9 2.24	59.4 2.34
CVDR407	4 7/16 in.				
CVDR408	4 1/2 in.	241.3 9.50	223.8 8.81	56.9 2.24	59.4 2.34
CVDR115MM	115 mm				
CVDR125MM	125 mm	241.3 9.50	223.8 8.81	56.9 2.24	59.4 2.34
CVDR415	4 15/16 in.				
CVDR500	5 in.	241.3 9.50	223.8 8.81	56.9 2.24	59.4 2.34
CVDR130MM	130 mm				

TABLE C-42. V-LOCK SERIES – TAPERED ADAPTER EQUIVALENT – OPEN-END COVER WITH DR SEAL – (QV[V]...PA, PN, PKT, PK, PH, PG, FC, FB, MC)

Cover Part No.	Shaft Dia.	A	B	C1	C2
	mm in.	mm in.	mm in.	mm in.	mm in.
CKDR115	1 15/16 in.	117.1 4.61	96.8 3.81	31.8 1.25	34.3 1.35
CKDR200	2 in.				
CKDR050MM	50 mm	132.1 5.20	116.1 4.57	27.4 1.08	30.0 1.18
CKDR203	2 3/16 in.				
CKDR204	2 1/4 in.	142.0 5.59	122.9 4.84	33.0 1.30	35.6 1.40
CKDR055MM	55 mm				
CKDR060MM	60 mm	168.1 6.62	149.1 5.87	38.9 1.53	41.4 1.63
CKDR207	2 7/16 in.				
CKDR208	2 1/2 in.	212.1 8.35	194.8 7.67	52.6 2.07	55.1 2.17
CKDR065MM	65 mm				
CKDR211	2 11/16 in.	241.3 9.50	223.8 8.81	56.9 2.24	59.4 2.34
CKDR212	2 3/4 in.				
CKDR070MM	70 mm	241.3 9.50	223.8 8.81	56.9 2.24	59.4 2.34
CKDR215	2 15/16 in.				
CKDR300	3 in.	241.3 9.50	223.8 8.81	56.9 2.24	59.4 2.34
CKDR075MM	75 mm				
CKDR303	3 3/16 in.	212.1 8.35	194.8 7.67	52.6 2.07	55.1 2.17
CKDR304	3 1/4 in.				
CKDR080MM	80 mm	241.3 9.50	223.8 8.81	56.9 2.24	59.4 2.34
CKDR085MM	85 mm				
CKDR307	3 7/16 in.	241.3 9.50	223.8 8.81	56.9 2.24	59.4 2.34
CKDR308	3 1/2 in.				
CKDR090MM	90 mm	241.3 9.50	223.8 8.81	56.9 2.24	59.4 2.34
CKDR311	3 11/16 in.				
CKDR312	3 3/4 in.	241.3 9.50	223.8 8.81	56.9 2.24	59.4 2.34
CKDR100MM	100 mm				
CKDR315	3 15/16 in.	241.3 9.50	223.8 8.81	56.9 2.24	59.4 2.34
CKDR400	4 in.				
CKDR110MM	110 mm	241.3 9.50	223.8 8.81	56.9 2.24	59.4 2.34
CKDR407	4 7/16 in.				
CKDR408	4 1/2 in.	241.3 9.50	223.8 8.81	56.9 2.24	59.4 2.34
CKDR115MM	115 mm				
CKDR125MM	125 mm	241.3 9.50	223.8 8.81	56.9 2.24	59.4 2.34
CKDR415	4 15/16 in.				
CKDR500	5 in.	241.3 9.50	223.8 8.81	56.9 2.24	59.4 2.34
CKDR130MM	130 mm				

SPHERICAL ROLLER BEARING SOLID-BLOCK HOUSED UNITS

SEAL AND COVER OPTIONS • URETHANE • OPEN-END COVERS WITH DR SEALS

TABLE C-43. CL AND EC SERIES – OPEN-END COVER WITH DR SEAL

Cover Part No.	Shaft Dia.	A	B	C1	C2
	mm in.	mm in.	mm in.	mm in.	mm in.
CJDR035MM	35 mm				
CJDR107	1 7/16 in.	97.0	76.7	31.8	34.3
CJDR108	1 1/2 in.	3.82	3.02	1.25	1.35
CJDR040MM	40 mm				
CJDR111	1 11/16 in.	101.9	81.6	31.8	34.3
CJDR112	1 3/4 in.	4.01	3.21	1.25	1.35
CJDR045MM	45 mm				
CJDR115	1 15/16 in.	106.9	86.6	31.8	34.3
CJDR200	2 in.	4.21	3.41	1.25	1.35
CJDR050MM	50 mm				
CJDR203	2 3/16 in.	117.1	96.8	31.8	34.3
CJDR204	2 1/4 in.	4.61	3.81	1.25	1.35
CJDR055MM	55 mm				
CJDR060MM	60 mm				
CJDR207	2 7/16 in.	132.1	116.1	27.4	30.0
CJDR208	2 1/2 in.	5.20	4.57	1.08	1.18
CJDR065MM	65 mm				
CJDR211	2 11/16 in.				
CJDR070MM	70 mm				
CJDR212	2 3/4 in.	142	122.9	33.0	35.6
CJDR215	2 15/16 in.	5.59	4.84	1.30	1.40
CJDR300	3 in.				
CJDR075MM	75 mm				
CJDR303	3 3/16 in.				
CJDR304	3 1/4 in.				
CJDR080MM	80 mm	168.1	149.1	38.9	41.4
CJDR085MM	85 mm	6.62	5.87	1.53	1.63
CJDR307	3 7/16 in.				
CJDR308	3 1/2 in.				
CJDR090MM	90 mm				
CJDR315	3 15/16 in.	192	174.8	44.5	47.0
CJDR400	4 in.	7.56	6.88	1.75	1.85
CJDR100MM	100 mm				
CJDR110MM	110 mm				
CJDR407	4 7/16 in.	212.1	194.8	52.6	55.1
CJDR408	4 1/2 in.	8.35	7.67	2.07	2.17
CJDR115MM	115 mm				
CJDR125MM	125 mm				
CJDR415	4 15/16 in.	241.3	223.8	56.9	59.4
CJDR500	5 in.	9.50	8.81	2.24	2.34
CJDR130MM	130 mm				
CJDR507	5 7/16 in.				
CJDR508	5 1/2 in.				
CJDR140MM	140 mm	271.6	254.0	56.9	59.4
CJDR515	5 15/16 in.	10.69	10.00	2.24	2.34
CJDR600	6 in.				
CJDR150MM	150 mm				
CJDR607	6 7/16 in.				
CJDR608	6 1/2 in.				
CJDR170MM	170 mm	304.8	287.3	56.9	59.4
CJDR615	6 15/16 in.	12.00	11.31	2.24	2.34
CJDR700	7 in.				
CJDR180MM	180 mm				

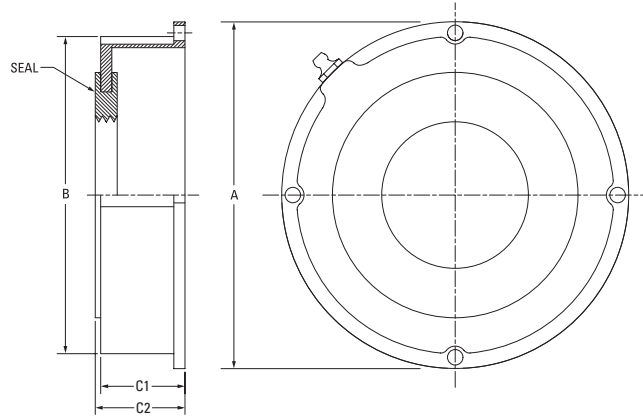

TABLE C-44. TA/DV SERIES – OPEN-END COVER WITH DR SEAL

Cover Part No.	Shaft Dia.	A	B	C1	C2
	mm in.	mm in.	mm in.	mm in.	mm in.
CKDR107	1 7/16 in.	101.9	81.5	31.8	34.3
CKDR108	1 1/2 in.	4.01	3.21	1.25	1.35
CKDR040MM	40 mm				
CKDR111	1 11/16 in.	106.9	86.6	31.8	34.3
CKDR112	1 3/4 in.	4.21	3.41	1.25	1.35
CKDR045MM	45mm				
CKDR115	1 15/16 in.	117.1	96.8	31.8	34.3
CKDR200	2 in.	4.61	3.81	1.25	1.35
CKDR050MM	50 mm				
CKDR055MM	55 mm	126.0	105.7	31.8	34.3
		4.96	4.16	1.25	1.35
CKDR203	2 3/16 in.	132.1	116.1	27.4	30.0
CKDR204	2 1/4 in.	5.20	4.57	1.08	1.18
CKDR060MM	60 mm				
CKDR207	2 7/16 in.	142.0	122.9	33.0	35.6
CKDR208	2 1/2 in.	5.59	4.84	1.30	1.40
CKDR065MM	65 mm				
CKDR211	2 11/16 in.	142.0	122.9	33.0	35.6
CKDR212	2 3/4 in.	5.59	4.84	1.30	1.40
CKDR070MM	70 mm				
CKDR215	2 15/16 in.	160.5	141.5	31.0	33.5
CKDR300	3 in.	6.32	5.57	1.22	1.32
CKDR075MM	75 mm				
CKDR080MM	80 mm				
CKDR303	3 3/16 in.	168.1	149.1	38.9	41.4
CKDR304	3 1/4 in.	6.62	5.87	1.53	1.63
CKDR085MM	85 mm	168.1	149.1	38.9	41.4
		6.62	5.87	1.53	1.63
CKDR307	3 7/16 in.	192.0	174.8	44.5	47.0
CKDR308	3 1/2 in.	7.56	6.88	1.75	1.85
CKDR090MM	90 mm				
CKDR315	3 15/16 in.	212.1	194.8	52.6	55.1
CKDR400	4 in.	8.35	7.67	2.07	2.17
CKDR100MM	100 mm				
CKDR403	4 3/16 in.	212.1	194.8	52.6	55.1
CKDR404	4 1/4 in.	8.35	7.67	2.07	2.17
CKDR110MM	110 mm				
CKDR407	4 7/16 in.	241.3	223.8	56.9	59.4
CKDR408	4 1/2 in.	9.50	8.81	2.24	2.34
CKDR115MM	115 mm				
CKDR415	4 15/16 in.	241.3	223.8	56.9	59.4
CKDR500	5 in.	9.50	8.81	2.24	2.34
CKDR125MM	125 mm				

OPEN-END COVERS WITH VR SEALS

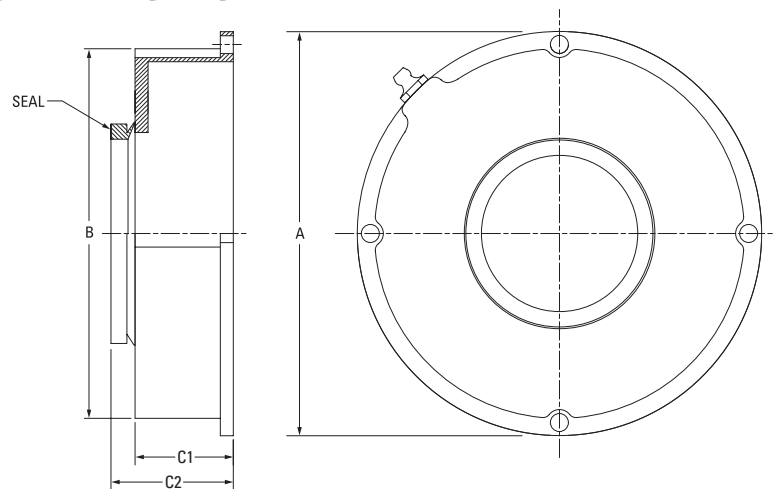

TABLE C-45. V-LOCK SERIES – STRAIGHT BORE EQUIVALENT – OPEN-END COVER WITH VR SEAL – (QV[V])...P, PL, SN, PF, PR, PX, PXT, C, CW, F, FL, FY, FX, TU)

Cover Part No. ⁽¹⁾	Shaft Dia.	A	B	C1	C2
	mm in.	mm in.	mm in.	mm in.	mm in.
CVVR11	1 15/16 in.	117.1	96.8	31.8	40.6
	2 in.				
	50 mm				
CVVR12	2 3/16 in.	126.0	105.7	31.8	40.6
	2 1/4 in.				
	55 mm				
CVVR14	60 mm	132.1	116.1	27.4	36.3
	2 7/16 in.				
	2 1/2 in.				
	65 mm				
CVVR16	70 mm	142.0	122.9	33.0	44.0
	2 11/16 in.				
	2 3/4 in.				
	2 15/16 in.				
	3 in.				
CVVR19	75 mm	168.1	149.1	38.9	50.0
	3 3/16 in.				
	3 1/4 in.				
	80 mm				
	85 mm				
	3 7/16 in.				
CVVR22	3 1/2 in.	212.1	194.8	52.6	63.5
	90 mm				
	3 11/16 in.				
	3 3/4 in.				
CVVR26	100 mm	241.3	223.8	56.9	69.6
	3 15/16 in.				
	4 in.				
	110 mm				
CVVR28	4 7/16 in.	241.3	223.8	56.9	69.6
	4 1/2 in.				
	115 mm				
CVVR28	125 mm	241.3	223.8	56.9	69.6
	4 15/16 in.				
	5 in.				
	130 mm				

TABLE C-46. V-LOCK SERIES – TAPERED ADAPTER EQUIVALENT – OPEN-END COVER WITH VR SEAL – (QV[V])...PA, PN, PKT, PK, PH, PG, FC, FB, MC)

Cover Part No.	Shaft Dia.	A	B	C1	C2
	mm in.	mm in.	mm in.	mm in.	mm in.
CKVR11	1 15/16 in.	117.1	96.8	31.8	40.6
	2 in.				
	50 mm				
CKVR13	2 3/16 in.	132.1	116.1	27.4	36.3
	2 1/4 in.				
	55 mm				
CKVR15	60 mm	142.0	122.9	33.0	41.9
	2 7/16 in.				
	2 1/2 in.				
	65 mm				
CKVR17	70 mm	160.6	141.5	31.0	41.9
	2 11/16 in.				
	2 3/4 in.				
	2 15/16 in.				
	3 in.				
CKVR20	75 mm	192.0	174.8	44.4	55.4
	3 3/16 in.				
	3 1/4 in.				
	80 mm				
	85 mm				
	3 7/16 in.				
CKVR22	3 1/2 in.	212.1	194.8	52.6	63.5
	90 mm				
	3 11/16 in.				
	3 3/4 in.				
CKVR24	100 mm	212.1	194.8	52.6	63.5
	3 15/16 in.				
	4 in.				
CKVR26	110 mm	241.3	223.8	56.9	69.6
	4 7/16 in.				
	4 1/2 in.				
CKVR28	115 mm	241.3	223.8	56.9	69.6
	4 15/16 in.				
	5 in.				
	130 mm				

⁽¹⁾Please refer to bore size when choosing cover for straight-bore V-Lock®.

SPHERICAL ROLLER BEARING SOLID-BLOCK HOUSED UNITS

SEAL AND COVER OPTIONS • URETHANE • OPEN-END COVERS WITH VR SEALS

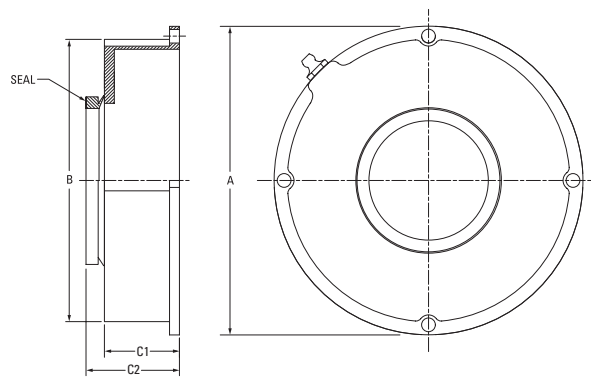

TABLE C-47. CL AND EC SERIES – OPEN-END COVER WITH VR SEAL

Cover Part No.	Shaft Dia.	A	B	C1	C2
	mm in.	mm in.	mm in.	mm in.	mm in.
CJVR08	35 mm	97.0 3.82	76.7 3.02	31.8 1.25	39.4 1.55
	1 7/16 in.				
	1 1/2 in.				
CJVR09	40 mm	101.9 4.01	81.5 3.21	31.8 1.25	40.6 1.60
	1 11/16 in.				
	1 3/4 in.				
CJVR10	45 mm	106.9 4.21	86.6 3.41	31.8 1.25	40.6 1.60
	1 15/16 in.				
	2 in.				
CJVR11	50 mm	117.1 4.61	96.8 3.81	31.8 1.25	40.6 1.60
	2 3/16 in.				
	2 1/4 in.				
CJVR13	55 mm	132.1 5.20	116.1 4.57	27.4 1.08	36.3 1.43
	60 mm				
	2 7/16 in.				
CJVR15	65 mm	142.0 5.59	122.9 4.84	33.0 1.30	44.0 1.73
	70 mm				
	2 3/4 in.				
	2 15/16 in.				
	3 in.				
CJVR18	75 mm	168.1 6.62	149.1 5.87	38.9 1.53	49.8 1.96
	80 mm				
	3 1/8 in.				
	3 1/4 in.				
	3 7/16 in.				
CJVR20	90 mm	192.0 7.56	174.8 6.88	44.5 1.75	55.4 2.18
	100 mm				
	3 15/16 in.				
CJVR22	110 mm	212.1 8.35	194.8 7.67	52.6 2.07	65.3 2.57
	115 mm				
	4 7/16 in.				
CJVR26	125 mm	241.3 9.50	223.8 8.81	56.9 2.24	69.6 2.74
	4 15/16 in.				
	5 in.				

TABLE C-48. TA/DV SERIES – OPEN-END COVER WITH VR SEAL

Cover Part No.	Shaft Dia.	A	B	C1	C2
	mm in.	mm in.	mm in.	mm in.	mm in.
CKVR09	1 7/16 in.	101.9 4.01	81.5 3.21	31.8 1.25	39.4 1.55
	1 1/2 in.				
	40 mm				
CKVR10	1 11/16 in.	106.9 4.21	86.6 3.41	31.8 1.25	40.6 1.6
	1 3/4 in.				
	45 mm				
CKVR11	1 15/16 in.	117.1 4.61	96.8 3.81	31.8 1.25	40.6 1.60
	2 in.				
	50 mm				
CKVR12	55 mm	126.0 4.96	105.7 4.16	31.8 1.25	40.6 1.6
	2 3/16 in.				
CKVR13	60 mm	132.1 5.20	116.1 4.57	27.4 1.08	36.3 1.43
	2 1/4 in.				
	65 mm				
CKVR15	70 mm	142.0 5.59	122.9 4.84	33.0 1.30	41.9 1.65
	2 7/16 in.				
	2 1/2 in.				
CKVR16	75 mm	142.0 5.59	122.9 4.84	33.0 1.30	41.9 1.65
	2 11/16 in.				
	2 3/4 in.				
CKVR17	80 mm	160.5 6.32	141.5 5.57	31.0 1.22	41.9 1.65
	2 15/16 in.				
	3 in.				
CKVR18	85 mm	168.1 6.62	149.1 5.87	38.9 1.53	49.8 1.96
	3 3/16 in.				
	3 1/4 in.				
CKVR19	90 mm	168.1 6.62	149.1 5.87	38.9 1.53	49.8 1.96
	3 7/16 in.				
CKVR20	95 mm	192.0 7.56	174.8 6.88	44.5 1.75	55.4 2.18
	100 mm				
	3 1/2 in.				
CKVR22	105 mm	212.1 8.35	194.8 7.67	52.6 2.07	63.5 2.50
	110 mm				
	4 in.				
CKVR24	115 mm	212.1 8.35	194.8 7.67	52.6 2.07	63.5 2.50
	120 mm				
	4 3/16 in.				
CKVR26	125 mm	241.3 9.50	223.8 8.81	56.9 2.24	69.6 2.74
	130 mm				
	4 7/16 in.				
CKVR28	135 mm	241.3 9.50	223.8 8.81	56.9 2.24	69.6 2.74
	140 mm				
	4 15/16 in.				

UFP AND HSY FLANGE BLOCK BACKING PLATE DIMENSIONS

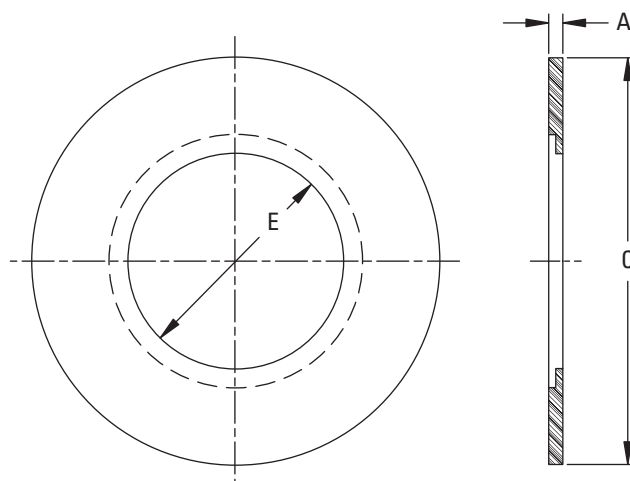

TABLE C-49. UFP BACKING PLATE DIMENSIONS⁽¹⁾

Cover Part No.	A	C	E
	mm in.	mm in.	mm in.
UFP035MM UFP107 UFP108	5.1 0.20	95.3 3.75	39.4 1.55
UFP111 UFP040MM UFP112 UFP045MM	5.1 0.20	105.9 4.17	44.7 1.76
UFP115 UFP200 UFP050MM	3.8 0.15	106.4 4.19	51.8 2.04
UFP203 UFP204 UFP055MM	6.4 0.25	114.6 4.51	59.7 2.35
UFP060MM UFP207 UFP208 UFP065MM	5.1 0.20	146.1 5.75	64.8 2.55
UFP211 UFP070MM UFP212 UFP215 UFP300 UFP075MM	5.1 0.20	146.6 5.77	78.0 3.07
UFP303 UFP304 UFP080MM UFP085MM UFP307 UFP308 UFP090MM	5.1 0.20	187.5 7.38	90.4 3.56
UFP315 UFP400 UFP100MM	5.1 0.20	206.5 8.13	104.1 4.10
UFP110MM UFP407 UFP408 UFP115MM	5.1 0.20	215.9 8.50	130.3 5.13
UFP125MM UFP415 UFP500 UFP130MM	5.1 0.20	299 11.77	128.3 5.05

⁽¹⁾Actual backing plate may differ from drawing.

SPHERICAL ROLLER BEARING SOLID-BLOCK HOUSED UNITS

SEAL AND COVER OPTIONS • UFP AND HSY FLANGE BLOCK BACKING PLATE DIMENSIONS

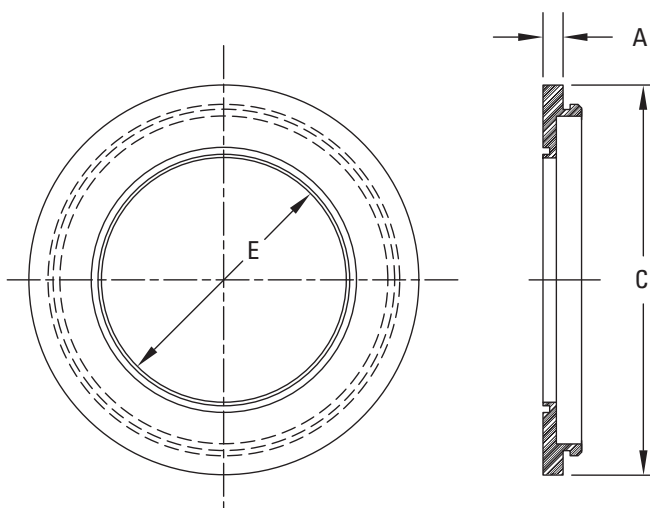

TABLE C-50. HSY BACKING PLATE DIMENSIONS

Cover Part No.	A	C	E
	mm in.	mm in.	mm in.
HSY115 HSY200 HSY050MM	5.1 0.20	108.0 4.25	68.3 2.69
HSY203 HSY204 HSY055MM	5.1 0.20	120.1 4.73	74.7 2.94
HSY060MM HSY207 HSY208 HSY065MM	6.4 0.25	133.4 5.25	81.0 3.19
HSY211 HSY070MM HSY212 HSY215 HSY300 HSY075MM	6.4 0.25	155.7 6.13	93.7 3.69
HSY303 HSY304 HSY080MM HSY085MM HSY307 HSY308 HSY090MM	5.1 0.20	181.1 7.13	106.4 4.19
HSY315 HSY400 HSY100MM	5.1 0.20	199.9 7.87	119.1 4.69
HSY110MM HSY407 HSY408 HSY115MM	7.6 0.30	254.0 10.00	131.8 5.19

V-LOCK® SERIES

The V-Lock® locking mechanism (U.S. Pat. No. 7344313) evenly distributes force on the shaft, helping eliminate fretting corrosion. V-Lock provides maximum holding power and prevents overtightening.

In response to customer input, V-Lock was specifically designed to address common spherical roller bearing solid-block housed unit problems:

- Reliable mechanical withdrawal.
- Preset spherical inner ring radial internal clearances (feeler gages are not required).
- Quick installation (typically 10 minutes or less).
- Highest shaft-holding power.
- Works well in high-speed applications where shaft centering is an issue.



Fig. C-41. V-Lock® series insert.

YOU HAVE CHOICES

For the V-Lock series, you can select either single-nut or double-nut versions and choose from many seal configurations and housing styles, which are shown on page C-74.

HOUSINGS

- Two-bolt pillow blocks.
- Four-bolt pillow blocks.
- Flange blocks.
- Piloted flange cartridges.
- Cartridge blocks.
- Take-up blocks.

SEALS

- Labyrinth: DuPont Teflon (T).
- Triple-lip: nitrile rubber (M), urethane (O) and DuPont Viton (N).
- Double-lip: nitrile rubber (B) and DuPont Viton (C).
- Steel and urethane closed-end covers (CS).
- Steel and urethane open-end covers (CV) with:
 - DuPont Teflon (T).
 - Triple-lip seal (DR).
 - V-ring seal (VR).

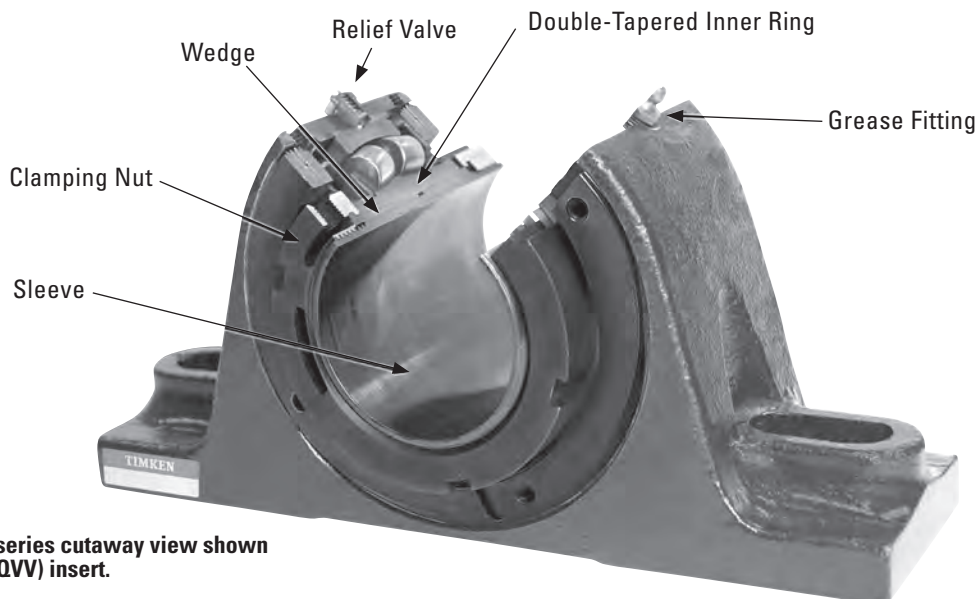

Fig. C-42. V-Lock series cutaway view shown with double-nut (QVV) insert.

SPHERICAL ROLLER BEARING SOLID-BLOCK HOUSED UNITS

V-LOCK SERIES

V-LOCK SERIES (ADAPTER LOCK) U.S. PAT. NO. 7344313

	Housing Type	Primary Seals						Secondary Seals and Covers						
		M	N	O	B	C	T	Open-End Cover			Closed-End Cover	HSY Flange Cartridge Backing Plate		UFP Backing Plate
								DR	VR	T		DR		
V-Lock® (Timken Exclusive Double Taper Lock)	Pillow Block	•	•	•	•	•	•	•	•	•	•	•		
	Flange Block	•	•	•	•	•	•	•	•	•	•	•		
	Piloted Flange Cartridge	•	•	•	•	•	•	•	•	•	•	•		
	Take-Up Block	•	•	•	•	•	•	•	•	•	•	•		
	Cartridge Block	•	•	•	•	•	•	•	•	•	•	•		
CL Series (Set Screw Lock)	Pillow Block	•	•	•	•	•	•	•	•	•	•	•		
	Flange Block	•	•	•	•	•	•	•	•	•	•	•		•
	Piloted Flange Cartridge	•	•	•	•	•	•	•	•	•	•	•	•	
	Take-Up Block	•	•	•	•	•	•	•	•	•	•	•		
	Cartridge Block	•	•	•	•	•	•	•	•	•	•	•		
	Hangar Block	•	•	•	•	•	•	•	•	•	•	•		
EC Series (Eccentric Lock)	Pillow Block	•	•	•	•	•	•	•	•	•	•	•		
	Flange Block	•	•	•	•	•	•	•	•	•	•	•		•
	Piloted Flange Cartridge	•	•	•	•	•	•	•	•	•	•	•	•	
	Take-Up Block	•	•	•	•	•	•	•	•	•	•	•		
	Cartridge Block	•	•	•	•	•	•	•	•	•	•	•		
	Hangar Block	•	•	•	•	•	•	•	•	•	•	•		
TA Series (Tapered Adapter Lock)	Pillow Block	•	•	•	•	•	•	•	•	•	•	•		
	Flange Block	•	•	•	•	•	•	•	•	•	•	•		
	Piloted Flange Cartridge	•	•	•	•	•	•	•	•	•	•	•		
	Cartridge Block	•	•	•	•	•	•	•	•	•	•	•		
DV Series (Tapered Adapter Lock)	Pillow Block	•	•	•	•	•	•	•	•	•	•	•		
	Flange Block	•	•	•	•	•	•	•	•	•	•	•		
	Piloted Flange Cartridge	•	•	•	•	•	•	•	•	•	•	•		

QVVP TWO-BOLT PILLOW BLOCKS – STRAIGHT BORE EQUIVALENT

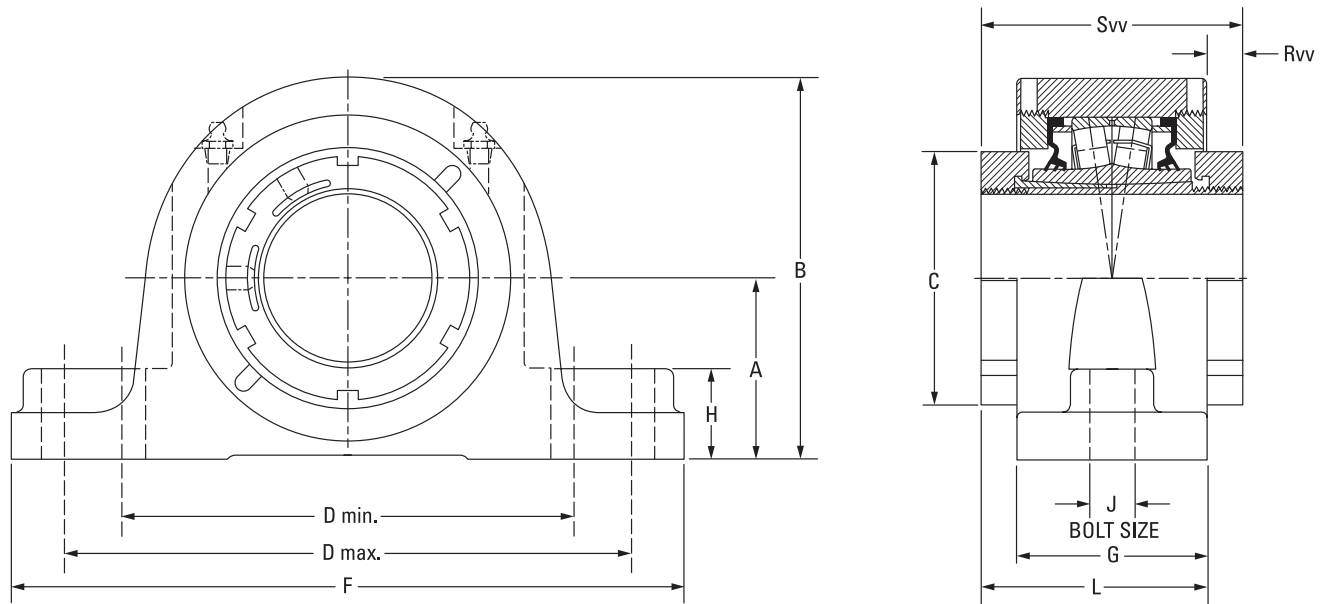

Bearing Part No. ⁽¹⁾	Shaft Dia.	Bearing No.	A	B	C	D min.	D max.	F	G	H	J	L	Rvv	Svv	Wt.
			mm in.	mm in.	mm in.	mm in.	mm in.	mm in.	mm in.	mm in.	mm in.	mm in.	mm in.	mm in.	mm in.
QVVP11V115S	1 15/16 in.	22211	57.2	122.2	75.9	152.4	181.1	225.6	62.0	31.8	16	82.0	20.1	102.1	6.4
QVVP11V200S	2 in.		2.25	4.81	2.99	6.00	7.13	8.88	2.44	1.25	5/8	3.23	0.79	4.02	14
QVVP11V050S	50 mm														
QVVP12V203S	2 3/16 in.	22212	63.5	133.4	80.3	165.1	200.2	244.6	66.8	31.8	16	84.6	17.8	102.1	7.7
QVVP12V204S	2 1/4 in.		2.50	5.25	3.16	6.50	7.88	9.63	2.63	1.25	5/8	3.33	0.70	4.02	17
QVVP12V055S	55 mm														
QVVP14V060S	60 mm	22214	69.9	147.3	94.0	174.8	219.2	260.4	73.7	35.1	16	88.9	15.2	103.9	10.0
QVVP14V207S	2 7/16 in.		2.75	5.80	3.70	6.88	8.63	10.25	2.90	1.38	5/8	3.50	0.60	4.09	22
QVVP14V208S	2 1/2 in.														
QVVP14V065S	65 mm	22216	79.5	164.3	106.4	200.2	244.6	295.4	76.2	35.1	20	91.2	15.0	106.2	12.7
QVVP16V211S	2 11/16 in.		3.13	6.47	4.19	7.88	9.63	11.63	3.00	1.38	3/4	3.59	0.59	4.18	28
QVVP16V212S	2 3/4 in.														
QVVP16V070S	70 mm	22219	95.3	195.3	124.5	238.3	285.8	342.9	86.6	47.8	24	102.1	15.5	117.6	20.4
QVVP16V215S	2 15/16 in.		3.75	7.69	4.90	9.38	11.25	13.50	3.41	1.88	7/8	4.02	0.61	4.63	45
QVVP16V300S	3 in.														
QVVP16V075S	75 mm	22222	104.9	219.7	139.7	255.0	320.0	362.0	102.6	50.8	24	116.6	14.0	130.3	26.8
QVVP19V303S	3 3/16 in.		4.13	8.65	5.50	10.04	12.60	14.25	4.04	2.00	1	4.59	0.55	5.13	59
QVVP19V304S	3 1/4 in.														
QVVP19V080S	80 mm	22222	104.9	219.7	139.7	255.0	320.0	362.0	102.6	50.8	24	116.6	14.0	130.3	26.8
QVVP19V085S	85 mm		4.13	8.65	5.50	10.04	12.60	14.25	4.04	2.00	1	4.59	0.55	5.13	59
QVVP19V307S	3 7/16 in.														
QVVP19V308S	3 1/2 in.	22222	104.9	219.7	139.7	255.0	320.0	362.0	102.6	50.8	24	116.6	14.0	130.3	26.8
QVVP19V090S	90 mm		4.13	8.65	5.50	10.04	12.60	14.25	4.04	2.00	1	4.59	0.55	5.13	59
QVVP22V311S	3 11/16 in.														
QVVP22V312S	3 3/4 in.	22222	104.9	219.7	139.7	255.0	320.0	362.0	102.6	50.8	24	116.6	14.0	130.3	26.8
QVVP22V100S	100 mm		4.13	8.65	5.50	10.04	12.60	14.25	4.04	2.00	1	4.59	0.55	5.13	59
QVVP22V315S	3 15/16 in.														
QVVP22V400S	4 in.														

⁽¹⁾Double-nut (QVV) part number shown. Single-nut (QV) version available upon request.

SPHERICAL ROLLER BEARING SOLID-BLOCK HOUSED UNITS

V-LOCK SERIES • QVVPL TWO-BOLT PILLOW BLOCKS – STRAIGHT BORE EQUIVALENT

QVVPL TWO-BOLT PILLOW BLOCKS – STRAIGHT BORE EQUIVALENT

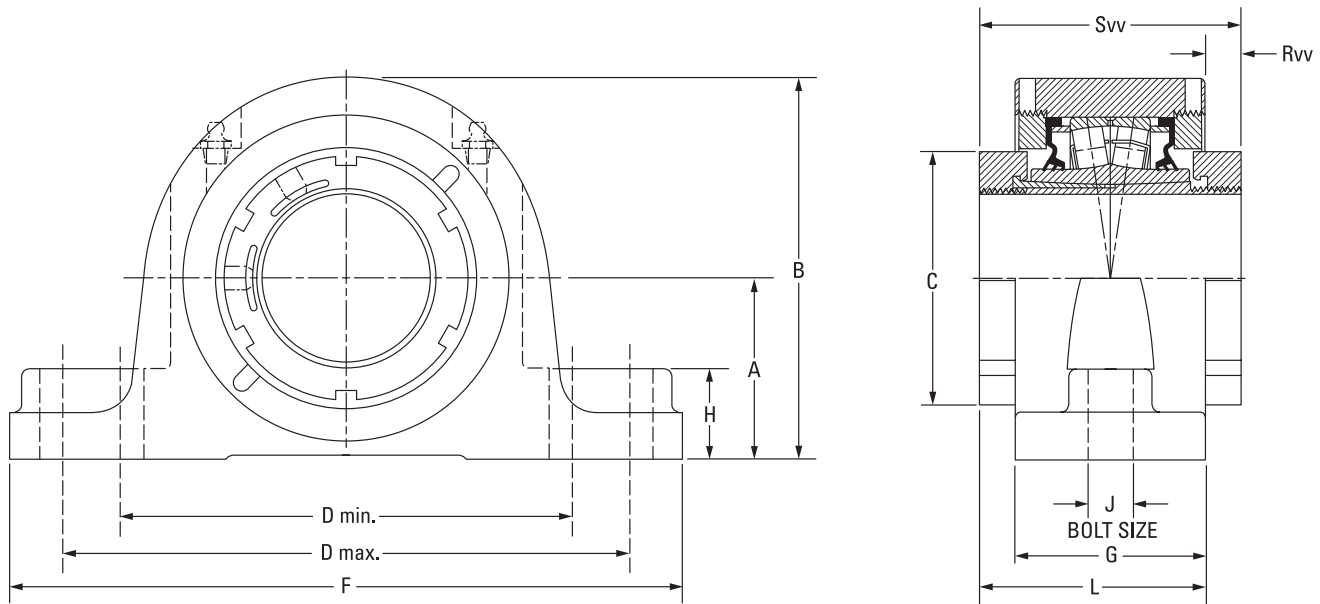

Bearing Part No. ⁽¹⁾	Shaft Dia.	Bearing No.	A	B	C	D min.	D max.	F	G	H	J	L	Rvv	Svv	Wt.
	mm in.		mm in.	mm in.	mm in.	mm in.	mm in.	mm in.	mm in.	mm in.	mm in.	mm in.	mm in.	mm in.	kg lbs.
QVVPL11V115S	1 15/16 in.	22211	57.2	122.2	75.9	150.6	161.5	212.9	62.0	31.8	16	82.0	20.1	102.1	6.4
QVVPL11V200S	2 in.		2.25	4.81	2.99	5.93	6.36	8.38	2.44	1.25	5/8	3.23	0.79	4.02	14
QVVPL11V050S	50 mm														
QVVPL12V203S	2 3/16 in.	22212	63.5	133.4	80.3	165.1	179.3	225.6	65.5	31.8	16	83.8	18.3	102.1	7.7
QVVPL12V204S	2 1/4 in.		2.50	5.25	3.16	6.50	7.06	8.88	2.58	1.25	5/8	3.30	0.72	4.02	17
QVVPL12V055S	55 mm														
QVVPL14V060S	60 mm	22214	69.9	147.3	94.0	173	189.0	235.0	73.7	35.1	16	88.9	15.2	103.9	10.0
QVVPL14V207S	2 7/16 in.		2.75	5.80	3.70	6.81	7.44	9.25	2.90	1.38	5/8	3.50	0.60	4.09	22
QVVPL14V208S	2 1/2 in.														
QVVPL14V065S	65 mm	22216	82.6	167.4	106.4	195.6	213.4	265.2	76.2	35.1	20	91.2	15.0	106.2	12.7
QVVPL16V211S	2 11/16 in.		3.25	6.59	4.19	7.70	8.40	10.44	3.00	1.38	3/4	3.59	0.59	4.18	28
QVVPL16V212S	2 3/4 in.														
QVVPL16V070S	70 mm	22219	95.3	195.3	124.5	235.0	273.1	330.2	86.6	47.8	24	102.1	15.5	117.6	20.4
QVVPL16V215S	2 15/16 in.		3.75	7.69	4.90	9.25	10.75	13.00	3.41	1.88	7/8	4.02	0.61	4.63	45
QVVPL16V300S	3 in.														
QVVPL16V075S	75 mm	22219	95.3	195.3	124.5	235.0	273.1	330.2	86.6	47.8	24	102.1	15.5	117.6	20.4
QVVPL19V303S	3 3/16 in.		3.75	7.69	4.90	9.25	10.75	13.00	3.41	1.88	7/8	4.02	0.61	4.63	45
QVVPL19V304S	3 1/4 in.														
QVVPL19V080S	80 mm	22219	95.3	195.3	124.5	235.0	273.1	330.2	86.6	47.8	24	102.1	15.5	117.6	20.4
QVVPL19V085S	85 mm		3.75	7.69	4.90	9.25	10.75	13.00	3.41	1.88	7/8	4.02	0.61	4.63	45
QVVPL19V307S	3 7/16 in.														
QVVPL19V308S	3 1/2 in.	22222	108	223	139.7	255.0	320.0	362.0	102.6	53.8	24	116.6	14.0	130.3	26.8
QVVPL19V090S	90 mm		4.25	8.78	5.50	10.04	12.60	14.25	4.04	2.12	1	4.59	0.55	5.13	59
QVVPL22V311S	3 11/16 in.														
QVVPL22V312S	3 3/4 in.	22222	108	223	139.7	255.0	320.0	362.0	102.6	53.8	24	116.6	14.0	130.3	26.8
QVVPL22V100S	100 mm		4.25	8.78	5.50	10.04	12.60	14.25	4.04	2.12	1	4.59	0.55	5.13	59
QVVPL22V315S	3 15/16 in.														
QVVPL22V400S	4 in.														

⁽¹⁾Double-nut (QVV) part number shown. Single-nut (QV) version available upon request.

QVPPA SAF TWO-BOLT PILLOW BLOCKS – TAPERED BORE EQUIVALENT

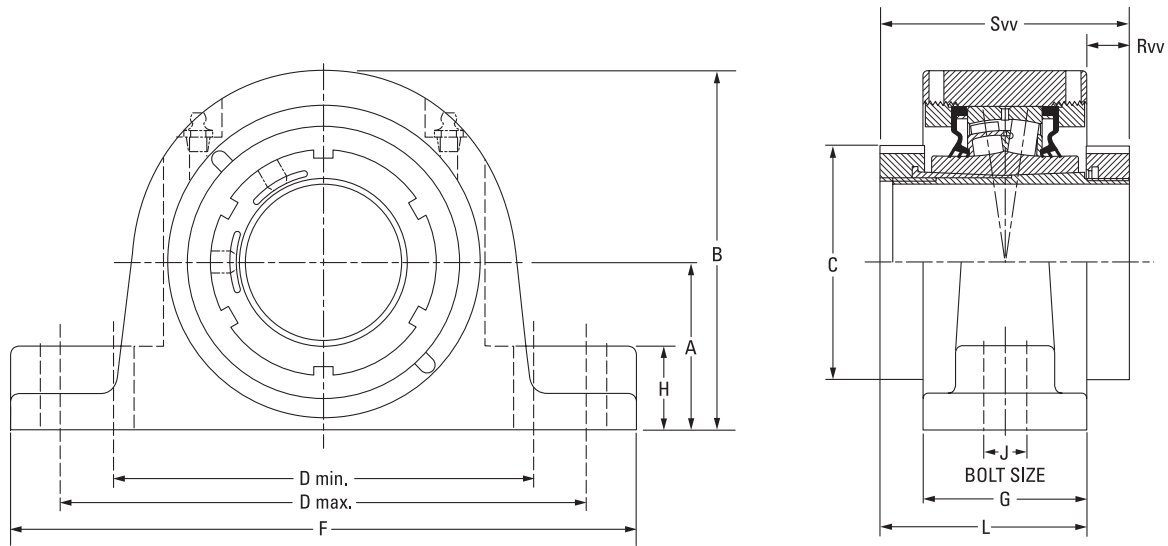

Bearing Part No. ⁽¹⁾	Shaft Dia.	Bearing No.	A	B	C	D min.	D max.	F	G	H	J	L	Rvv	Svv	Wt.
	mm in.		mm in.	mm in.	mm in.	mm in.	mm in.	mm in.	mm in.	mm in.	mm in.	mm in.	mm in.	mm in.	kg lbs.
QVPPA13V203S	2 3/16 in.	22213	76.2	151.1	80.3	182.9	233.7	261.9	68.6	31.2	16	85.3	16.8	102.1	10.4
QVPPA13V204S	2 1/4 in.		3.00	5.95	3.16	7.20	9.20	10.31	2.70	1.23	5/8	3.36	0.66	4.02	23
QVPPA13V055S	55 mm														
QVPPA15V060S	60 mm	22215													
QVPPA15V207S	2 7/16 in.		82.6	163.3	94.0	200.2	244.6	276.4	68.6	31.8	16	86.4	17.8	103.9	12.2
QVPPA15V208S	2 1/2 in.		3.25	6.43	3.70	7.88	9.63	10.88	2.70	1.25	5/8	3.40	0.70	4.09	27
QVPPA15V065S	65 mm	22217													
QVPPA17V211S	2 11/16 in.														
QVPPA17V212S	2 3/4 in.		95.3	186	106.4	241.3	279.4	320.8	76.2	33.8	20	91.2	15.0	106.2	15.0
QVPPA17V070S	70 mm	22217	3.75	7.32	4.19	9.50	11.00	12.63	3.00	1.33	3/4	3.59	0.59	4.18	33
QVPPA17V215S	2 15/16 in.														
QVPPA17V300S	3 in.														
QVPPA17V075S	75 mm	22220													
QVPPA20V303S	3 3/16 in.														
QVPPA20V304S	3 1/4 in.		114.3	219.2	124.5	276.4	327.2	368.3	86.9	41.4	24	102.4	15.5	117.6	29.5
QVPPA20V080S	80 mm	22220	4.50	8.63	4.90	10.88	12.88	14.50	3.42	1.63	7/8	4.03	0.61	4.63	65
QVPPA20V085S	85 mm														
QVPPA20V307S	3 7/16 in.														
QVPPA20V308S	3 1/2 in.	22222													
QVPPA20V090S	90 mm														
QVPPA22V311S	3 11/16 in.		125.5	240.5	139.7	317.5	368.3	406.4	100.6	50.8	24	115.6	15.0	130.3	38.1
QVPPA22V312S	3 3/4 in.	22222	4.94	9.47	5.50	12.50	14.50	16.00	3.96	2.00	7/8	4.55	0.59	5.13	84
QVPPA22V100S	100 mm														
QVPPA22V315S	3 15/16 in.														
QVPPA22V400S	4 in.	22226													
QVPPA26V110S	110 mm														
QVPPA26V407S	4 7/16 in.		152.4	284.0	174.8	362.0	400.1	444.5	128	51.8	24	153.2	25.1	178.3	61.7
QVPPA26V408S	4 1/2 in.	22226	6.00	11.18	6.88	14.25	15.75	17.50	5.04	2.04	1	6.03	0.99	7.02	136
QVPPA26V115S	115 mm														
QVPPA28V125S	125 mm														
QVPPA28V415S	4 15/16 in.	22228	152.4	290.8	190.0	384.3	447.8	499.9	85.6	51.8	30	132.0	46.5	178.3	61.8
QVPPA28V500S	5 in.		6.00	11.45	7.48	15.13	17.63	19.68	3.37	2.04	1 1/4	5.20	1.83	7.02	136
QVPPA28V130S	130 mm														

⁽¹⁾Double-nut (QVV) part number shown. Single-nut (QV) version available upon request.

SPHERICAL ROLLER BEARING SOLID-BLOCK HOUSED UNITS

V-LOCK SERIES • QVVPN SN-STYLE TWO-BOLT PILLOW BLOCKS – TAPERED BORE EQUIVALENT

QVVPN SN-STYLE TWO-BOLT PILLOW BLOCKS – TAPERED BORE EQUIVALENT

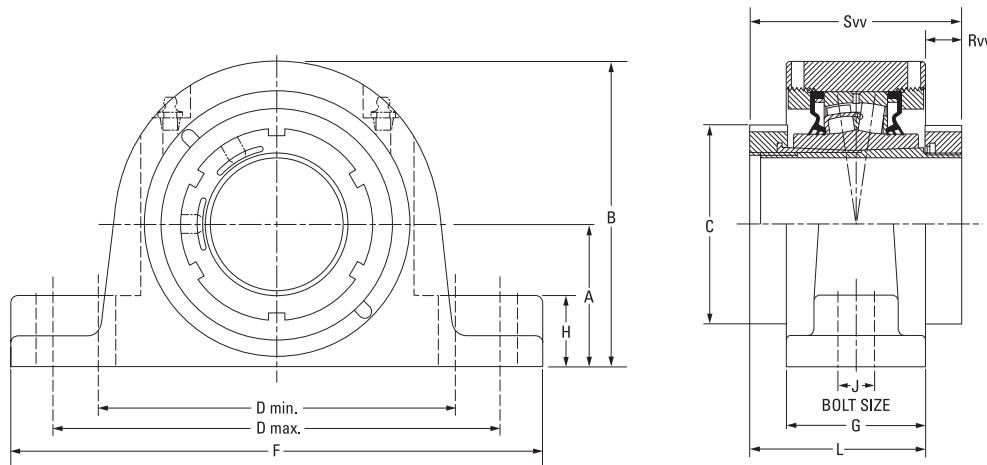

Bearing Part No. ⁽¹⁾	Shaft Dia.	Bearing No.	A	B	C	D min.	D max.	F	G	H	J	L	Rvv	Svv	Wt.	
	mm in.		mm in.	mm in.	mm in.	mm in.	mm in.	mm in.	mm in.	mm in.	mm in.	mm in.	mm in.	mm in.	kg lbs.	
QVVPN11V115S	1 15/16 in.	22211	69.9	135.4	75.9	165.1	221.0	251.0	60.5	31.8	16	81.3	20.8	102.1	7.7	
QVVPN11V200S	2 in.		2.750	5.33	2.99	6.50	8.70	9.88	2.38	1.25	5/8	3.20	0.82	4.02	17	
QVVPN11V050S	50 mm															
QVVPN12V055S	55 mm	22212	70.0	140.5	80.0	177.8	219.2	254.0	60.5	31.8	16	81.3	20.8	102.1	9.1	
			2.756	5.53	3.15	7.00	8.63	10.00	2.38	1.25	5/8	3.20	0.82	4.02	20	
QVVPN13V203S	2 3/16 in.	22213	80.0	154.9	80.3	182.9	233.7	261.9	68.6	35.1	16	85.3	16.8	102.1	10.4	
QVVPN13V204S	2 1/4 in.		3.150	6.10	3.16	7.20	9.20	10.31	2.70	1.38	5/8	3.36	0.66	4.02	23	
QVVPN14V060S	60 mm	22214	80.0	154.9	94.0	182.9	233.7	261.9	68.6	35.1	16	86.4	17.8	104.0	10.4	
			3.150	6.10	3.70	7.20	9.20	10.31	2.70	1.38	5/8	3.40	0.70	4.09	23	
QVVPN15V207S	2 7/16 in.	22215	80.0	160.8	94.0	200.2	244.6	276.4	68.6	29.2	16	86.4	17.8	103.9	12.2	
QVVPN15V208S	2 1/2 in.		3.150	6.33	3.70	7.88	9.63	10.88	2.70	1.15	5/8	3.40	0.70	4.09	27	
QVVPN15V065S	65 mm															
QVVPN16V211S	2 11/16 in.	22216	95.0	180.3	106.0	235.0	266.7	315.0	72.6	31.8	20	89.4	16.8	106.0	13.6	
QVVPN16V212S	2 3/4 in.		3.74	7.10	4.17	9.25	10.50	12.40	2.86	1.25	3/4	3.52	0.66	4.17	30	
QVVPN16V070S	70 mm															
QVVPN17V215S	2 15/16 in.	22217	95.3	185.9	106.4	241.3	279.4	320.8	76.2	33.8	20	91.2	15.0	106.2	15.0	
QVVPN17V300S	3 in.		3.750	7.32	4.19	9.50	11.00	12.63	3.00	1.33	3/4	3.59	0.59	4.18	33	
QVVPN17V075S	75 mm															
QVVPN19V303S	3 3/16 in.	22219	100.0	195.3	124.0	285.8	295.4	346.2	79.8	38.9	20	99.1	19.3	118.1	22.2	
QVVPN19V304S	3 1/4 in.		3.937	7.69	4.88	11.25	11.63	13.63	3.14	1.53	3/4	3.90	0.76	4.65	49	
QVVPN19V080S	80 mm															
QVVPN19V085S	85 mm	22219	112.0	212.3	124.0	285.8	295.4	346.2	82.8	38.9	20	100.6	17.8	118.1	23.1	
			4.409	8.36	4.88	11.25	11.63	13.63	3.26	1.53	3/4	3.96	0.70	4.65	51	
QVVPN20V307S	3 7/16 in.	22220	112.0	216.9	124.5	276.4	327.2	368.3	86.9	38.9	24	102.4	15.5	117.6	29.5	
QVVPN20V308S	3 1/2 in.		4.409	8.54	4.90	10.88	12.88	14.50	3.42	1.53	7/8	4.03	0.61	4.63	65	
QVVPN20V090S	90 mm															
QVVPN22V311S	3 11/16 in.	22222	125.0	240.5	139.7	317.5	368.3	406.4	100.6	50.8	24	115.6	15.0	130.3	38.1	
QVVPN22V312S	3 3/4 in.		4.921	9.47	5.50	12.50	14.50	16.00	3.96	2.00	7/8	4.55	0.59	5.13	84	
QVVPN22V100S	100 mm															
QVVPN22V315S	3 15/16 in.															
QVVPN22V400S	4 in.															
QVVPN24V110S	110 mm	22224	140.0	262.9	174.8	344.4	355.6	409.7	97.8	50.8	24	138.2	40.4	178.3	49.9	
			5.512	10.35	6.88	13.56	14.00	16.13	3.85	2.00	7/8	5.44	1.59	7.02	110	
QVVPN26V407S	4 7/16 in.	22226	150.0	281.7	174.8	367.3	400.1	444.5	128.0	49.3	24	153.2	25.1	178.3	61.7	
QVVPN26V408S	4 1/2 in.		5.906	11.09	6.88	14.46	15.75	17.50	5.04	1.94	1	6.03	0.99	7.02	136	
QVVPN26V115S	115 mm															
QVVPN28V125S	125 mm	22228	150.0	288.5	190.0	384.3	447.8	499.9	85.6	49.3	30	132.0	46.5	178.3	61.8	
QVVPN28V415S	4 15/16 in.		5.906	11.36	7.48	15.13	17.63	19.68	3.37	1.94	1 1/4	5.20	1.83	7.02	136	
QVVPN28V500S	5 in.															
QVVPN28V130S	130 mm															

⁽¹⁾Double-nut (QVV) part number shown. Single-nut (QV) version available upon request.

SPHERICAL ROLLER BEARING SOLID-BLOCK HOUSED UNITS

V-LOCK SERIES • QVVSN SN-STYLE TWO-BOLT PILLOW BLOCKS – PURE METRIC DESIGN

QVVSN SN-STYLE TWO-BOLT PILLOW BLOCKS – PURE METRIC DESIGN

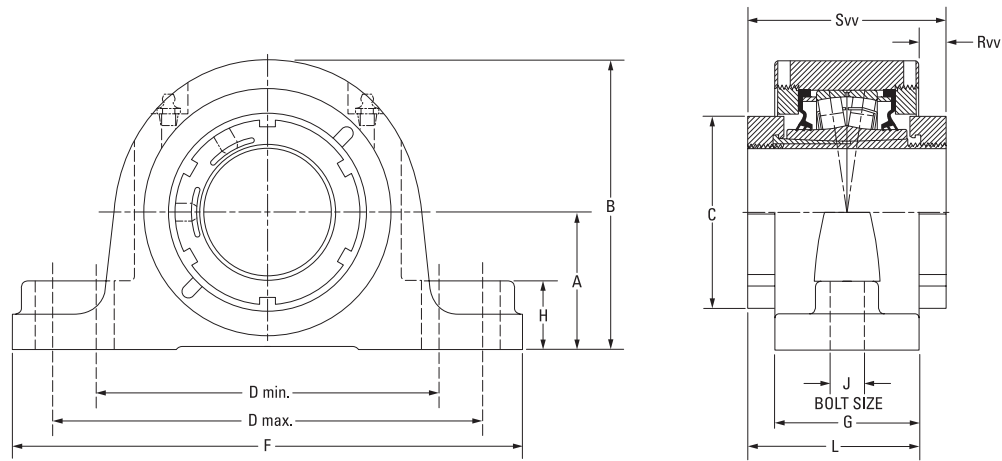

Bearing Part No. ⁽¹⁾	Shaft Dia.	Bearing No.	A	B	C	D min.	D max.	F	G	H	J	L	Rvv	Svv	Wt.
	mm in.		mm in.	mm in.	mm in.	mm in.	mm in.	mm in.	mm in.	mm in.	mm in.	mm in.	mm in.	mm in.	kg lbs.
QVVSN11V115S	1 15/16 in.	22211	70	136	76	183	216	254	68	25	16	85	17	102	13.2
QVVSN11V200S	2 in.		2.76	5.35	2.99	7.20	8.50	10.00	2.68	1.00	5/8	3.35	0.67	4.02	29
QVVSN11V050S	50 mm														
QVVSN12V203S	2 3/16 in.	22212	70	141	80	183	216	254	68	25	16	85	17	102	13.2
QVVSN12V204S	2 1/4 in.		2.76	5.55	3.15	7.20	8.50	10.00	2.68	1.00	5/8	3.35	0.67	4.02	29
QVVSN12V055S	55 mm														
QVVSN14V060S	60 mm	22214	80	157	94	196	235	275	74	35	16	89	15	104	16.8
QVVSN14V207S	2 7/16 in.		3.15	6.18	3.70	7.72	9.25	10.83	2.91	1.38	5/8	3.50	0.59	4.09	37
QVVSN14V208S	2 1/2 in.														
QVVSN14V065S	65 mm	22216	95	183	106	241	279	316	76	34	20	91	15	106	20.9
QVVSN16V211S	2 11/16 in.		3.74	7.2	4.17	9.49	10.98	12.44	2.99	1.33	3/4	3.58	0.59	4.17	46
QVVSN16V212S	2 3/4 in.														
QVVSN16V070S	70 mm	22219	100	200	124	279	292	345	86	39	20	102	16	118	25.4
QVVSN16V215S	2 15/16 in.		3.94	7.87	4.88	10.98	11.50	13.58	3.39	1.53	3/4	4.02	0.63	4.65	56
QVVSN16V300S	3 in.														
QVVSN16V075S	75 mm	22219	112	212	124	279	292	345	86	39	20	102	16	118	25.4
QVVSN19V303S	3 3/16 in.		4.41	8.34	4.88	10.98	11.50	13.58	3.39	1.53	3/4	4.02	0.63	4.65	56
QVVSN19V304S	3 1/4 in.														
QVVSN19V080S	80 mm	22219	112	212	124	290	327	380	86	39	24	102	16	118	25.4
QVVSN19V085S	85 mm		4.41	8.34	4.88	11.42	12.87	14.96	3.39	1.53	7/8	4.02	0.63	4.65	56
QVVSN19V307S	3 7/16 in.														
QVVSN19V308S	3 1/2 in.	22222	125	241	140	319	366	410	101	50	24	116	15	130	35.8
QVVSN19V090S	90 mm		4.92	9.49	5.51	12.56	14.41	16.14	3.98	2.00	7/8	4.57	0.59	5.12	79
QVVSN22V311S	3 11/16 in.														
QVVSN22V312S	3 3/4 in.	22226	140	270	175	332	365	410	113	39	24	146	33	178	39.9
QVVSN22V100S	100 mm		5.51	10.63	6.89	13.07	14.37	16.14	4.45	1.53	7/8	5.75	1.30	7.01	88
QVVSN22V315S	3 15/16 in.														
QVVSN22V400S	4 in.	22226	150	280	175	367	400	445	113	49	24	146	33	178	39.9
QVVSN26V110S	110 mm		5.91	11.02	6.89	14.45	15.75	17.52	4.45	1.92	7/8	5.75	1.30	7.01	88
QVVSN26V407S	4 7/16 in.														
QVVSN26V408S	4 1/2 in.	22228	150	290	190	402	435	500	117	49	30	148	31	178	39.9
QVVSN26V115S	115 mm		5.91	11.41	7.48	15.83	17.13	19.68	4.61	1.92	1 1/4	5.83	1.22	7.01	88
QVVSN28V125S	125 mm														
QVVSN28V415S	4 15/16 in.	22228	150	290	190	402	435	500	117	49	30	148	31	178	39.9
QVVSN28V500S	5 in.		5.91	11.41	7.48	15.83	17.13	19.68	4.61	1.92	1 1/4	5.83	1.22	7.01	88
QVVSN28V130S	130 mm														

⁽¹⁾Double-nut (QVV) part number shown. Single-nut (QV) version available upon request.

SPHERICAL ROLLER BEARING SOLID-BLOCK HOUSED UNITS

V-LOCK SERIES • QVVPKT 9000 SERIES TWO-BOLT PILLOW BLOCKS – TAPERED BORE EQUIVALENT

QVVPKT 9000 SERIES TWO-BOLT PILLOW BLOCKS – TAPERED BORE EQUIVALENT

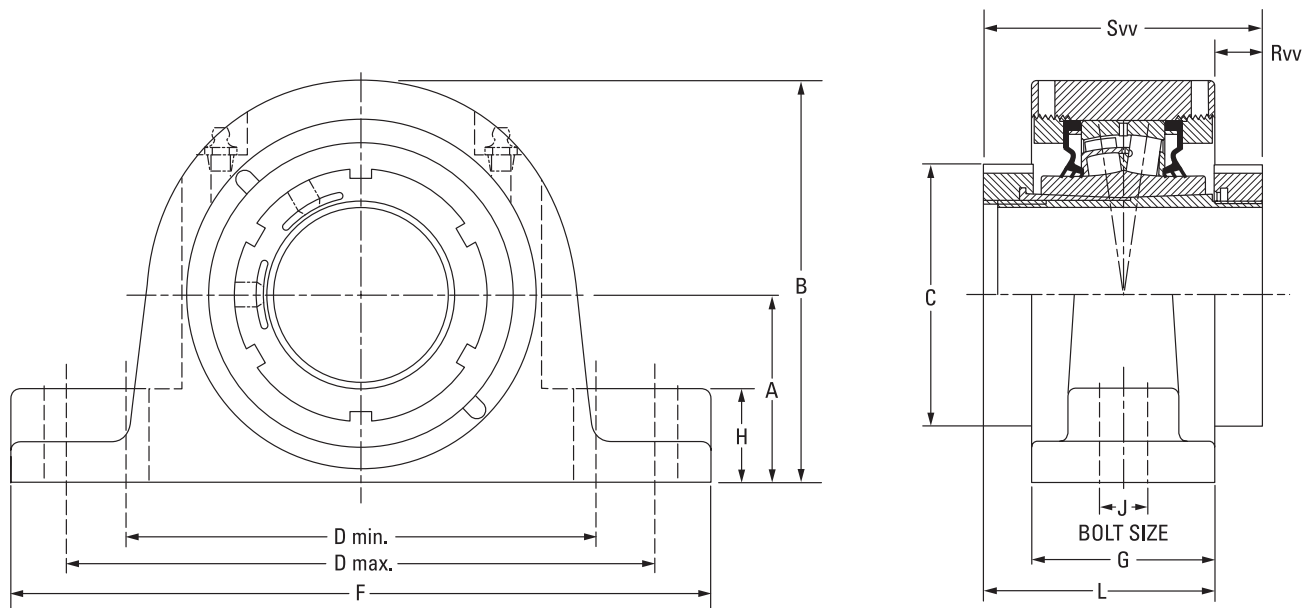

Bearing Part No. ⁽¹⁾	Shaft Dia.	Bearing No.	A	B	C	D min.	D max.	F	G	H	J	L	Rvv	Svv	Wt.	
	mm in.		mm in.	mm in.	mm in.	mm in.	mm in.	mm in.	mm in.	mm in.	mm in.	mm in.	mm in.	mm in.	kg lbs.	
QVVPKT13V203S	2 3/16 in.	22213	76.2	153.7	80.3	194.6	223.0	285.8	73.7	35.1	20	87.9	14.2	102.1	10.0	
QVVPKT13V204S	2 1/4 in.		3.00	6.05	3.16	7.66	8.78	11.25	2.90	1.38	3/4	3.46	0.56	4.02	22	
QVVPKT13V055S	55 mm															
QVVPKT15V060S	60 mm	22215	88.9	173.7	94.0	230.1	265.2	330.2	75.7	35.1	24	89.9	14.2	103.9	12.7	
QVVPKT15V207S	2 7/16 in.		3.50	6.84	3.70	9.06	10.44	13.00	2.98	1.38	7/8	3.54	0.56	4.09	28	
QVVPKT15V208S	2 1/2 in.															
QVVPKT15V065S	65 mm															

⁽¹⁾Double-nut (QVV) part number shown. Single-nut (QV) version available upon request.

SPHERICAL ROLLER BEARING SOLID-BLOCK HOUSED UNITS

V-LOCK SERIES • QVVPF FOUR-BOLT PILLOW BLOCKS – STRAIGHT BORE EQUIVALENT

QVVPF FOUR-BOLT PILLOW BLOCKS – STRAIGHT BORE EQUIVALENT

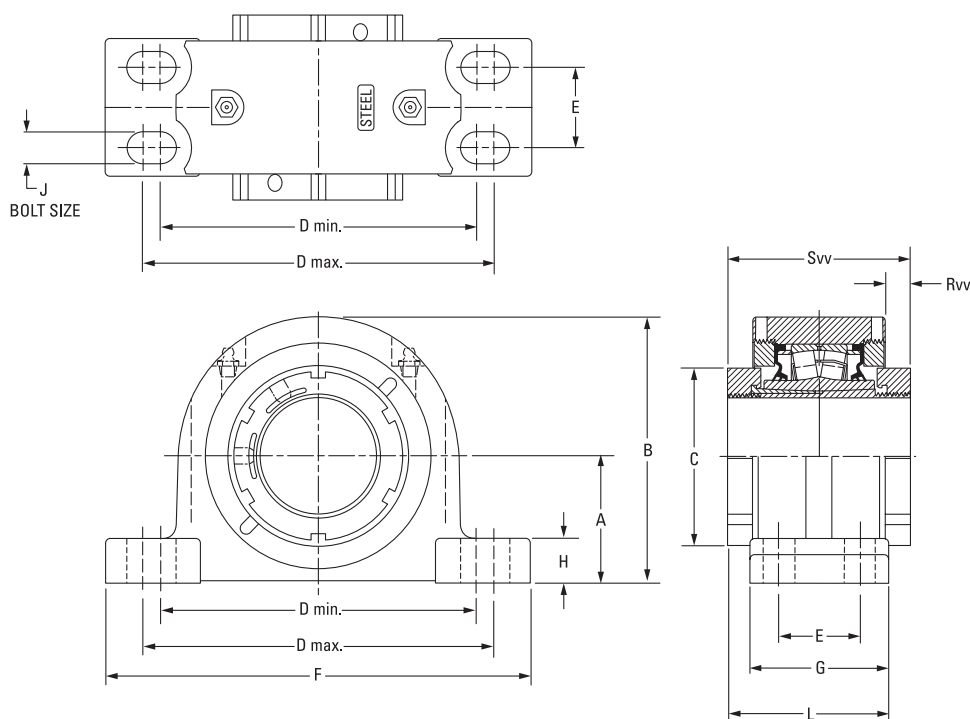

Bearing Part No. ⁽¹⁾	Shaft Dia.	Bearing No.	A	B	C	D min.	D max.	E	F	G	H	J	L	Rvv	Svv	Wt.
	mm in.		mm in.	mm in.	mm in.	mm in.	mm in.	mm in.	mm in.	mm in.	mm in.	mm in.	mm in.	mm in.	mm in.	kg lbs.
QVVPF14V060S	60 mm	22214	69.9 2.75	147.3 5.80	94.0 3.70	174.8 6.88	193.8 7.63	44.5 1.75	235.0 9.25	76.2 3.00	24.9 0.98	16 5/8	90.2 3.55	15.2 0.60	103.9 4.09	9.1 20
QVVPF14V207S	2 7/16 in.															
QVVPF14V208S	2 1/2 in.															
QVVPF14V065S	65 mm	22216	82.6 3.25	167.4 6.59	106.4 4.19	193.0 7.60	231.1 9.10	47.8 1.88	265.2 10.44	79.5 3.13	32.8 1.29	16 5/8	93.0 3.66	15.2 0.60	106.2 4.18	12.2 27
QVVPF16V211S	2 11/16 in.															
QVVPF16V212S	2 3/4 in.															
QVVPF16V070S	70 mm	22219	95.3 3.75	195.3 7.69	124.5 4.90	225.6 8.88	276.4 10.88	50.8 2.00	312.4 12.30	95.3 3.75	39.6 1.56	20 3/4	106.4 4.19	14.5 0.57	117.6 4.63	22.2 49
QVVPF16V215S	2 15/16 in.															
QVVPF16V300S	3 in.															
QVVPF16V075S	75 mm	22222	108.0 4.25	223.0 8.78	139.7 5.50	276.4 10.88	339.9 13.38	57.2 2.25	378.0 14.88	109.5 4.31	35.6 1.40	20 3/4	119.9 4.72	14.7 0.58	130.3 5.13	30.4 67
QVVPF19V303S	3 3/16 in.															
QVVPF19V304S	3 1/4 in.															
QVVPF19V080S	80 mm	22226	120.7 4.75	250.7 9.87	174.8 6.88	301.8 11.88	368.3 14.50	63.5 2.50	409.7 16.13	120.7 4.75	40.1 1.58	20 3/4	149.6 5.89	32.8 1.29	178.3 7.02	37.2 82
QVVPF19V085S	85 mm															
QVVPF19V307S	3 7/16 in.															
QVVPF19V308S	3 1/2 in.	22228	139.7 5.50	279.7 11.01	190.0 7.48	349.3 13.75	403.4 15.88	69.9 2.75	444.5 17.50	128.0 5.04	39.1 1.54	24 7/8	153.2 6.03	31.5 1.24	178.3 7.02	60.8 134
QVVPF19V090S	90 mm															
QVVPF22V311S	3 11/16 in.															
QVVPF22V312S	3 3/4 in.															
QVVPF22V100S	100 mm															
QVVPF22V315S	3 15/16 in.															
QVVPF22V400S	4 in.															
QVVPF26V110S	110 mm															
QVVPF26V407S	4 7/16 in.															
QVVPF26V408S	4 1/2 in.															
QVVPF26V115S	115 mm															
QVVPF28V125S	125 mm															
QVVPF28V415S	4 15/16 in.															
QVVPF28V500S	5 in.															
QVVPF28V130S	130 mm															

⁽¹⁾Double-nut (QVV) part number shown. Single-nut (QV) version available upon request.

SPHERICAL ROLLER BEARING SOLID-BLOCK HOUSED UNITS

V-LOCK SERIES • QVVPR FOUR-BOLT PILLOW BLOCKS – STRAIGHT BORE EQUIVALENT

QVVPR FOUR-BOLT PILLOW BLOCKS – STRAIGHT BORE EQUIVALENT

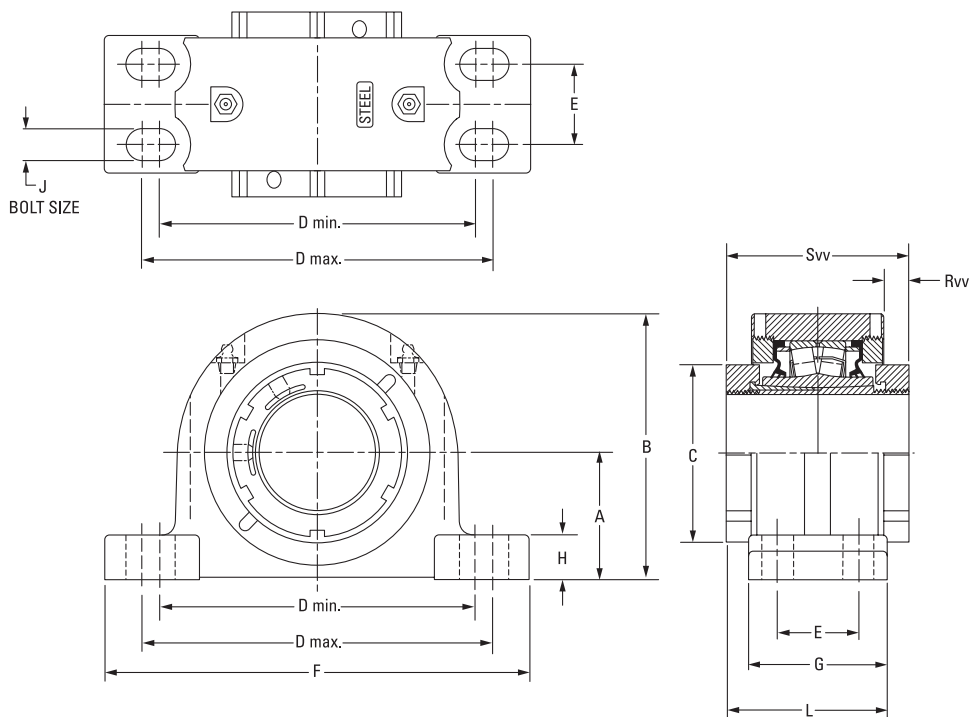

Bearing Part No. ⁽¹⁾	Shaft Dia.	Bearing No.	A	B	C	D min.	D max.	E	F	G	H	J	L	Rvv	Svv	Wt.
			mm in.	mm in.	mm in.	mm in.	mm in.	mm in.	mm in.	mm in.	mm in.	mm in.	mm in.	mm in.	mm in.	mm in.
QVVPR14V060S	60 mm	22214	69.9 2.75	147.3 5.80	94.0 3.70	181.1 7.13	222.2 8.75	47.8 1.88	260.4 10.25	82.6 3.25	24.9 0.98	16 5/8	93.2 3.67	15.2 0.60	103.9 4.09	9.1 20
QVVPR14V207S	2 7/16 in.															
QVVPR14V208S	2 1/2 in.															
QVVPR14V065S	65 mm	22216	79.5 3.13	164.3 6.47	106.4 4.19	203.2 8.00	243.8 9.60	54.1 2.13	275.1 10.83	85.9 3.38	29.5 1.16	16 5/8	96.0 3.78	15.2 0.60	106.2 4.18	12.2 27
QVVPR16V211S	2 11/16 in.															
QVVPR16V212S	2 3/4 in.															
QVVPR16V070S	70 mm	22219	95.3 3.75	195.3 7.69	124.5 4.90	235.0 9.25	285.8 11.25	60.5 2.38	346.2 13.63	95.3 3.75	39.6 1.56	20 3/4	106.4 4.19	14.5 0.57	117.6 4.63	22.2 49
QVVPR16V215S	2 15/16 in.															
QVVPR16V300S	3 in.															
QVVPR16V075S	75 mm	22219	95.3 3.75	195.3 7.69	124.5 4.90	235.0 9.25	285.8 11.25	60.5 2.38	346.2 13.63	95.3 3.75	39.6 1.56	20 3/4	106.4 4.19	14.5 0.57	117.6 4.63	22.2 49
QVVPR19V303S	3 3/16 in.															
QVVPR19V304S	3 1/4 in.															
QVVPR19V080S	80 mm	22219	95.3 3.75	195.3 7.69	124.5 4.90	235.0 9.25	285.8 11.25	60.5 2.38	346.2 13.63	95.3 3.75	39.6 1.56	20 3/4	106.4 4.19	14.5 0.57	117.6 4.63	22.2 49
QVVPR19V085S	85 mm															
QVVPR19V307S	3 7/16 in.															
QVVPR19V308S	3 1/2 in.	22219	95.3 3.75	195.3 7.69	124.5 4.90	235.0 9.25	285.8 11.25	60.5 2.38	346.2 13.63	95.3 3.75	39.6 1.56	20 3/4	106.4 4.19	14.5 0.57	117.6 4.63	22.2 49
QVVPR19V090S	90 mm															

⁽¹⁾Double-nut (QVV) part number shown. Single-nut (QV) version available upon request.

QVVPX 5000 SERIES FOUR-BOLT PILLOW BLOCKS – STRAIGHT BORE EQUIVALENT

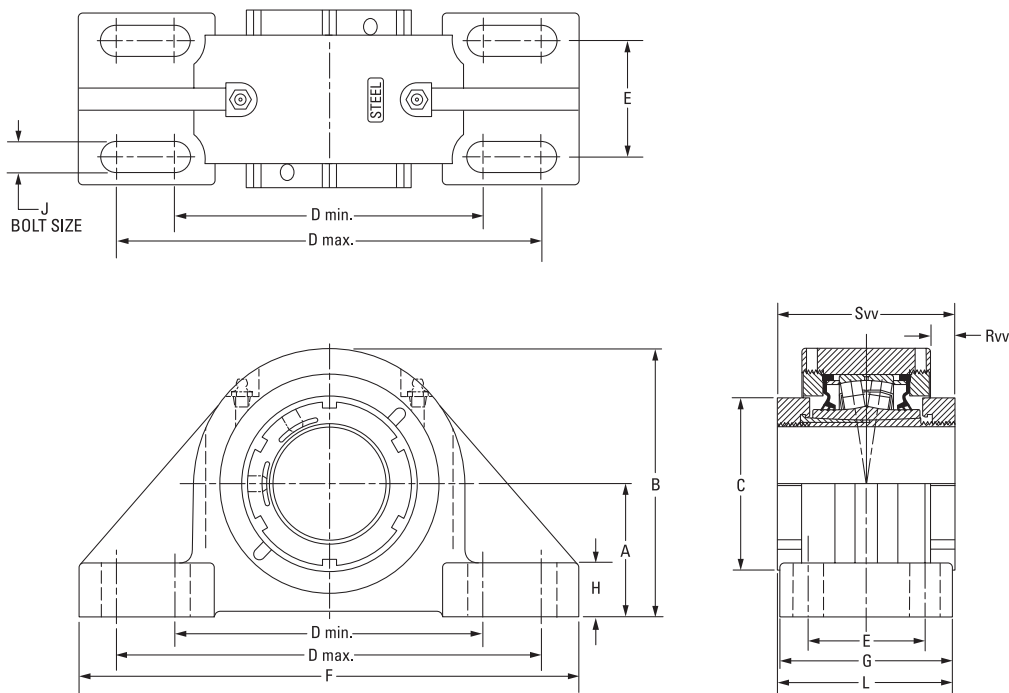

Bearing Part No. ⁽¹⁾	Shaft Dia.	Bearing No.	A	B	C	D min.	D max.	E	F	G	H	J	L	Rvv	Sv	Wt.
	mm in.		mm in.	mm in.	mm in.	mm in.	mm in.	mm in.	mm in.	mm in.	mm in.	mm in.	mm in.	mm in.	mm in.	kg lbs.
QVVPX14V060S	60 mm	22214	76.2 3.00	153.7 6.05	94.0 3.70	176.3 6.94	242.8 9.56	66.8 2.63	285.8 11.25	98.6 3.88	31.0 1.22	16 5/8	101.3 3.99	15.2 0.60	103.9 4.09	10.4 23
QVVPX14V207S	2 7/16 in.															
QVVPX14V208S	2 1/2 in.															
QVVPX14V065S	65 mm	22216	88.9 3.50	173.5 6.83	106.4 4.19	230.1 9.06	265.2 10.44	69.9 2.75	330.2 13.00	108.0 4.25	39.1 1.54	20 3/4	107.2 4.22	14.2 0.56	106.2 4.18	12.7 28
QVVPX16V211S	2 11/16 in.															
QVVPX16V212S	2 3/4 in.															
QVVPX16V070S	70 mm	22219	101.6 4.00	201.2 7.92	124.5 4.90	274.6 10.81	309.6 12.19	76.2 3.00	381.0 15.00	120.7 4.75	38.1 1.50	20 3/4	119.1 4.69	14.5 0.57	117.6 4.63	22.2 49
QVVPX16V215S	2 15/16 in.															
QVVPX16V300S	3 in.															
QVVPX16V075S	75 mm	22222	127.0 5.00	239.8 9.44	139.7 5.50	317.5 12.50	355.6 14.00	88.9 3.50	425.5 16.75	139.7 5.50	41.4 1.63	24 7/8	135.1 5.32	15.2 0.60	130.3 5.13	30.4 67
QVVPX19V303S	3 3/16 in.															
QVVPX19V304S	3 1/4 in.															
QVVPX19V080S	80 mm	22226	146.1 5.75	273.8 10.78	174.8 6.88	354.1 13.94	395.2 15.56	101.6 4.00	469.9 18.50	158.8 6.25	45.7 1.80	24 1	168.7 6.64	38.4 1.51	178.3 7.02	37.2 82
QVVPX19V085S	85 mm															
QVVPX19V307S	3 7/16 in.															
QVVPX19V308S	3 1/2 in.	22228	155.6 6.125	293.4 11.55	190.0 7.48	387.4 15.25	452.5 16.75	108.0 4.25	514.4 20.25	171.5 6.75	50.8 2.00	24 1 1/8	175.0 6.89	30.7 1.21	178.3 7.02	61.7 136
QVVPX19V090S	90 mm															
QVVPX22V311S	3 11/16 in.															
QVVPX22V312S	3 3/4 in.	22226	146.1 5.75	273.8 10.78	174.8 6.88	354.1 13.94	395.2 15.56	101.6 4.00	469.9 18.50	158.8 6.25	45.7 1.80	24 1	168.7 6.64	38.4 1.51	178.3 7.02	37.2 82
QVVPX22V315S	3 15/16 in.															
QVVPX22V400S	4 in.															
QVVPX22V100S	100 mm	22228	155.6 6.125	293.4 11.55	190.0 7.48	387.4 15.25	452.5 16.75	108.0 4.25	514.4 20.25	171.5 6.75	50.8 2.00	24 1 1/8	175.0 6.89	30.7 1.21	178.3 7.02	61.7 136
QVVPX26V110S	110 mm															
QVVPX26V407S	4 7/16 in.															
QVVPX26V408S	4 1/2 in.	22228	155.6 6.125	293.4 11.55	190.0 7.48	387.4 15.25	452.5 16.75	108.0 4.25	514.4 20.25	171.5 6.75	50.8 2.00	24 1 1/8	175.0 6.89	30.7 1.21	178.3 7.02	61.7 136
QVVPX26V115S	115 mm															
QVVPX28V125S	125 mm															
QVVPX28V415S	4 15/16 in.	22228	155.6 6.125	293.4 11.55	190.0 7.48	387.4 15.25	452.5 16.75	108.0 4.25	514.4 20.25	171.5 6.75	50.8 2.00	24 1 1/8	175.0 6.89	30.7 1.21	178.3 7.02	61.7 136
QVVPX28V500S	5 in.															
QVVPX28V130S	130 mm															

⁽¹⁾Double-nut (QVV) part number shown. Single-nut (QV) version available upon request.

SPHERICAL ROLLER BEARING SOLID-BLOCK HOUSED UNITS

V-LOCK SERIES • QVVPXT 5000 SERIES TWO-BOLT PILLOW BLOCKS – STRAIGHT BORE EQUIVALENT

QVVPXT 5000 SERIES TWO-BOLT PILLOW BLOCKS – STRAIGHT BORE EQUIVALENT

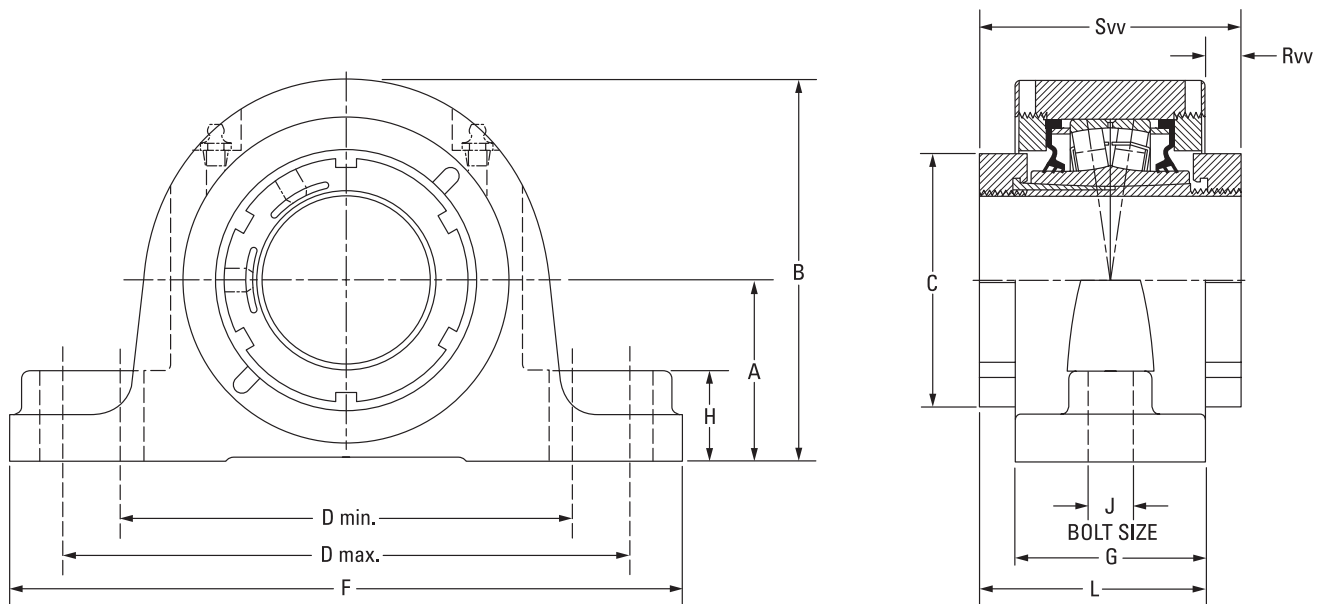

Bearing Part No. ⁽¹⁾	Shaft Size	Bearing No.	A	B	C	D min.	D max.	F	G	H	J	L	Rvv	Svv	Wt.	
			mm in.	mm in.	mm in.	mm in.	mm in.	mm in.	mm in.	mm in.	mm in.	mm in.	mm in.	mm in.	kg lbs.	
QVVPXT14V060S	60 mm	22214	76.2 3.00	153.7 6.05	94.0 3.70	194.6 7.66	233.0 8.78	285.8 11.25	73.7 2.90	35.1 1.38	20 ¾	88.9 3.50	15.2 0.60	103.9 4.09	10.0 22	
QVVPXT14V207S	2 7/16 in.															
QVVPXT14V208S	2 ½ in.															
QVVPXT14V065S	65 mm	22216	88.9 3.50	173.7 6.84	106.4 4.19	230.1 9.06	265.2 10.44	330.2 13.00	75.7 2.98	35.1 1.38	24 7/8	90.9 3.58	15.2 0.60	106.2 4.18	12.7 28	
QVVPXT16V211S	2 11/16 in.															
QVVPXT16V212S	2 ¾ in.															
QVVPXT16V070S	70 mm															
QVVPXT16V215S	2 15/16 in.															
QVVPXT16V300S	3 in.															
QVVPXT16V075S	75 mm															

⁽¹⁾Double-nut (QVV) part number shown. Single-nut (QV) version available upon request.

SPHERICAL ROLLER BEARING SOLID-BLOCK HOUSED UNITS

V-LOCK SERIES • QVVPG SN-STYLE FOUR-BOLT PILLOW BLOCKS – TAPERED BORE EQUIVALENT

QVVPG SN-STYLE FOUR-BOLT PILLOW BLOCKS – TAPERED BORE EQUIVALENT

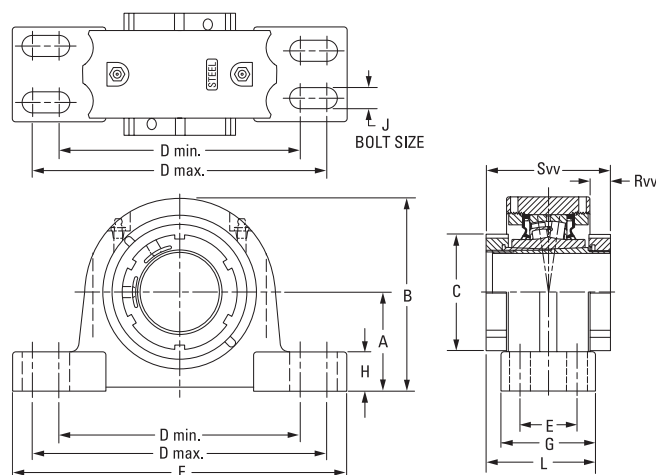

Bearing Part No. ⁽¹⁾	Shaft Dia.	Bearing No.	A	B	C	D min.	D max.	E	F	G	H	J	L	Rvv	Svv	Wt.	
	mm in.		mm in.	mm in.	mm in.	mm in.	mm in.	mm in.	mm in.	mm in.	mm in.	mm in.	mm in.	mm in.	mm in.	kg lbs.	
QVVPG11V115S	1 15/16 in.	22211	69.9	134.9	75.9	182.4	217.4	39.9	251.0	68.6	31.8	16	85.3	20.8	102.1	8.6	
QVVPG11V200S	2 in.		2.75	5.31	2.99	7.18	8.56	1.57	9.88	2.70	1.25	5/8	3.36	0.82	4.02	19	
QVVPG11V050S	50 mm																
QVVPG12V055S	55 mm	22212	70.0	140.5	80.0	177.8	219.2	35.1	254.0	69.9	31.8	12	86.1	20.8	102.1	9.9	
			2.756	5.53	3.15	7.00	8.63	1.38	10.00	2.75	1.25	1/2	3.39	0.82	4.02	22	
QVVPG13V203S	2 3/16 in.	22213	80.0	154.9	80.3	182.4	217.4	48.0	261.9	82.6	35.1	16	92.5	17.0	102.1	11.3	
QVVPG13V204S	2 1/4 in.		3.15	6.10	3.16	7.18	8.56	1.89	10.31	3.25	1.38	5/8	3.64	0.67	4.02	25	
QVVPG14V060S	60 mm	22214	80.0	154.9	94.0	182.4	217.4	48.0	261.9	82.6	35.1	16	93.2	86.1	103.9	11.3	
			3.15	6.10	3.70	7.18	8.56	1.89	10.31	3.25	1.38	5/8	3.67	3.39	4.09	25	
QVVPG15V207S	2 7/16 in.	22215	80.0	162.1	94.0	201.7	246.1	39.6	276.4	79.5	30.2	16	91.7	15.7	103.9	13.2	
QVVPG15V208S	2 1/2 in.		3.15	6.38	3.70	7.94	9.69	1.56	10.88	3.13	1.19	5/8	3.61	0.62	4.09	29	
QVVPG15V065S	65 mm																
QVVPG16V211S	2 11/16 in.	22216	95.0	180.3	105.9	235.0	266.7	50.0	315.0	89.9	31.8	16	98.0	16.8	105.9	14.9	
QVVPG16V212S	2 3/4 in.		3.74	7.10	4.17	9.25	10.50	1.97	12.4	3.54	1.25	5/8	3.86	0.66	4.17	33	
QVVPG16V070S	70 mm																
QVVPG17V215S	2 15/16 in.	22217	95.0	182.9	106.4	240.0	287.3	52.3	320.8	92.2	31.8	20	99.3	15.0	106.2	16.8	
QVVPG17V300S	3 in.		3.74	7.20	4.19	9.44	11.31	2.06	12.63	3.63	1.25	3/4	3.91	0.59	4.18	37	
QVVPG17V075S	75 mm																
QVVPG19V303S	3 3/16 in.	22219	100.0	195.3	124.0	282.7	298.5	50.0	344.9	100.1	39.6	16	109.2	19.3	118.1	24.5	
QVVPG19V304S	3 1/4 in.		3.937	7.69	4.88	11.13	11.75	1.97	13.58	3.94	1.56	5/8	4.30	0.76	4.65	54	
QVVPG19V080S	80 mm																
QVVPG19V085S	85 mm	22219	112.0	212.3	124.0	282.7	298.5	50.0	344.9	100.1	39.6	16	109.2	17.8	118.1	25.4	
			4.409	8.36	4.88	11.13	11.75	1.97	13.58	3.94	1.56	5/8	4.30	0.70	4.65	56	
QVVPG20V307S	3 7/16 in.	22220	112.0	214.6	124.5	276.4	339.9	60.5	381.0	109.5	39.6	20	113.5	11.2	117.6	31.8	
QVVPG20V308S	3 1/2 in.		4.409	8.45	4.90	10.88	13.38	2.38	15.00	4.31	1.56	3/4	4.47	0.44	4.63	70	
QVVPG20V090S	90 mm																
QVVPG22V311S	3 11/16 in.	22222	125.0	238.3	139.7	301.8	368.3	69.9	409.7	120.7	44.5	20	125.5	14.5	130.3	39.5	
QVVPG22V312S	3 3/4 in.		4.921	9.38	5.50	11.88	14.50	2.75	16.13	4.75	1.75	3/4	4.94	0.57	5.13	87	
QVVPG22V100S	100 mm																
QVVPG22V315S	3 15/16 in.																
QVVPG22V400S	4 in.																
QVVPG24V110S	110 mm	22224	140.0	262.9	174.8	342.9	355.6	70.1	410.0	120.7	50.8	16	149.6	40.4	178.3	49.9	
			5.512	10.35	6.88	13.50	14.00	2.76	16.14	4.75	2.00	5/8	5.89	1.59	7.02	110	
QVVPG26V407S	4 7/16 in.	22226	150.0	281.7	174.8	367.3	400.1	81.0	444.5	128.0	49.3	24	153.2	36.6	178.3	61.7	
QVVPG26V408S	4 1/2 in.		5.906	11.09	6.88	14.46	15.75	3.19	17.50	5.04	1.94	1	6.03	1.44	7.02	136	
QVVPG26V115S	115 mm																
QVVPG28V125S	125 mm	22228	150.0	288.5	190.0	384.3	447.8	80.0	500.4	128.0	49.3	24	152.9	31.8	178.3	61.7	
QVVPG28V415S	4 15/16 in.		5.906	11.36	7.48	15.13	17.63	3.15	19.70	5.04	1.94	1	6.02	1.25	7.02	136	
QVVPG28V500S	5 in.																
QVVPG28V130S	130 mm																

⁽¹⁾Double-nut (QVV) part number shown. Single-nut (QV) version available upon request.

SPHERICAL ROLLER BEARING SOLID-BLOCK HOUSED UNITS

V-LOCK SERIES • QVVPH SAF-STYLE FOUR-BOLT PILLOW BLOCKS – TAPERED BORE EQUIVALENT

QVVPH SAF-STYLE FOUR-BOLT PILLOW BLOCKS – TAPERED BORE EQUIVALENT

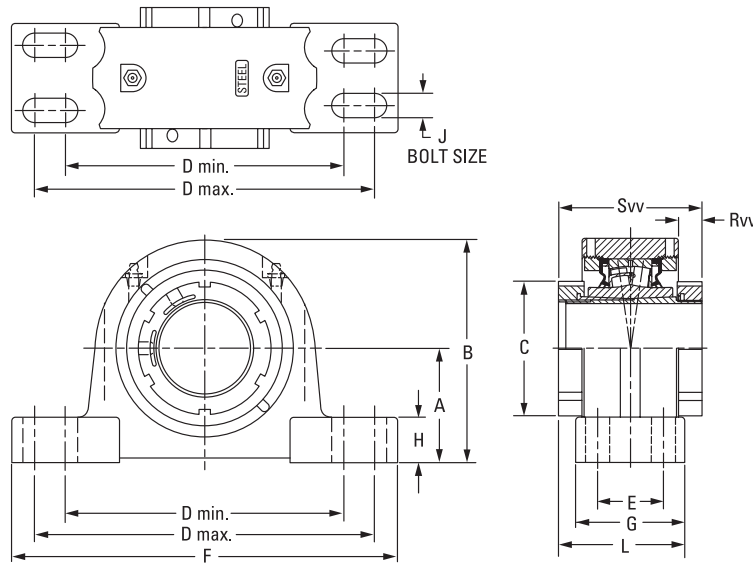

Bearing Part No. ⁽¹⁾	Shaft Dia.	Bearing No.	A	B	C	D min.	D max.	E	F	G	H	J	L	Rvv	Svv	Wt.
	mm in.		mm in.	mm in.	mm in.	mm in.	mm in.	mm in.	mm in.	mm in.	mm in.	mm in.	mm in.	mm in.	mm in.	kg lbs.
QVVPH11V115S	1 15/16 in.	22211	69.9	134.9	75.9	182.4	217.4	39.9	251.0	68.6	31.8	16	85.3	20.8	102.1	8.6
QVVPH11V200S	2 in.		2.75	5.31	2.99	7.18	8.56	1.57	9.88	2.70	1.25	5/8	3.36	0.82	4.02	19
QVVPH11V050S	50 mm															
QVVPH13V203S	2 3/16 in.	22213	76.2	151.1	80.3	182.4	217.4	50.8	261.9	82.6	31.2	12	92.5	17.0	102.1	11.3
QVVPH13V204S	2 1/4 in.		3.00	5.95	3.16	7.18	8.56	2.00	10.31	3.25	1.23	1/2	3.64	0.67	4.02	25
QVVPH13V055S	55 mm															
QVVPH15V060S	60 mm	22215	82.6	162.1	94.0	201.7	246.1	47.8	276.4	79.5	32.8	12	91.7	18.0	103.9	13.2
QVVPH15V207S	2 7/16 in.		3.25	6.38	3.70	7.94	9.69	1.88	10.88	3.13	1.29	1/2	3.61	0.71	4.09	29
QVVPH15V208S	2 1/2 in.															
QVVPH15V065S	65 mm	22217	95.3	182.9	106.4	240.0	287.3	54.1	320.8	92.2	32.0	16	99.3	15.0	106.2	16.8
QVVPH17V211S	2 11/16 in.		3.75	7.20	4.19	9.44	11.31	2.13	12.63	3.63	1.26	5/8	3.91	0.59	4.18	37
QVVPH17V212S	2 3/4 in.															
QVVPH17V070S	70 mm	22220	114.3	216.9	124.5	276.4	339.9	60.5	381.0	109.5	41.9	20	113.5	11.2	117.6	31.8
QVVPH17V215S	2 15/16 in.		4.50	8.54	4.90	10.88	13.38	2.38	15.00	4.31	1.65	3/4	4.47	0.44	4.63	70
QVVPH17V300S	3 in.															
QVVPH17V075S	75 mm	22222	125.5	238.3	139.7	301.8	368.3	69.9	406.4	120.7	45.0	20	125.5	14.5	130.3	39.5
QVVPH20V303S	3 3/16 in.		4.94	9.38	5.50	11.88	14.50	2.75	16.00	4.75	1.77	3/4	4.94	0.57	5.13	87
QVVPH20V304S	3 1/4 in.															
QVVPH20V080S	80 mm	22226	152.4	284.0	174.8	362.0	400.1	82.6	444.5	128.0	51.8	20	153.2	36.6	178.3	61.7
QVVPH20V085S	85 mm		4.50	9.38	5.50	11.88	14.50	2.75	16.00	4.75	1.77	3/4	4.94	0.57	5.13	87
QVVPH20V307S	3 7/16 in.															
QVVPH20V308S	3 1/2 in.	22228	152.4	290.8	190.0	406.4	435.1	85.9	500.4	128.0	51.8	24	152.9	31.8	178.3	61.7
QVVPH20V090S	90 mm		6.00	11.18	6.88	14.25	15.75	3.25	17.50	5.04	2.04	3/4	6.03	1.44	7.02	136
QVVPH22V311S	3 11/16 in.															
QVVPH22V312S	3 3/4 in.	22228	152.4	290.8	190.0	406.4	435.1	85.9	500.4	128.0	51.8	24	152.9	31.8	178.3	61.7
QVVPH22V100S	100 mm		6.00	11.45	7.48	16.00	17.13	3.38	19.70	5.04	2.04	1	6.02	1.25	7.02	136
QVVPH22V315S	3 15/16 in.															
QVVPH22V400S	4 in.															
QVVPH26V110S	110 mm	22226	152.4	284.0	174.8	362.0	400.1	82.6	444.5	128.0	51.8	20	153.2	36.6	178.3	61.7
QVVPH26V407S	4 7/16 in.		6.00	11.18	6.88	14.25	15.75	3.25	17.50	5.04	2.04	3/4	6.03	1.44	7.02	136
QVVPH26V408S	4 1/2 in.															
QVVPH26V115S	115 mm	22228	152.4	290.8	190.0	406.4	435.1	85.9	500.4	128.0	51.8	24	152.9	31.8	178.3	61.7
QVVPH28V125S	125 mm		6.00	11.45	7.48	16.00	17.13	3.38	19.70	5.04	2.04	1	6.02	1.25	7.02	136
QVVPH28V415S	4 15/16 in.															
QVVPH28V500S	5 in.															
QVVPH28V130S	130 mm															

⁽¹⁾Double-nut (QVV) part number shown. Single-nut (QV) version available upon request.

SPHERICAL ROLLER BEARING SOLID-BLOCK HOUSED UNITS

V-LOCK SERIES • QVVPK 9000 SERIES FOUR-BOLT PILLOW BLOCKS – TAPERED BORE EQUIVALENT

QVVPK 9000 SERIES FOUR-BOLT PILLOW BLOCKS – TAPERED BORE EQUIVALENT

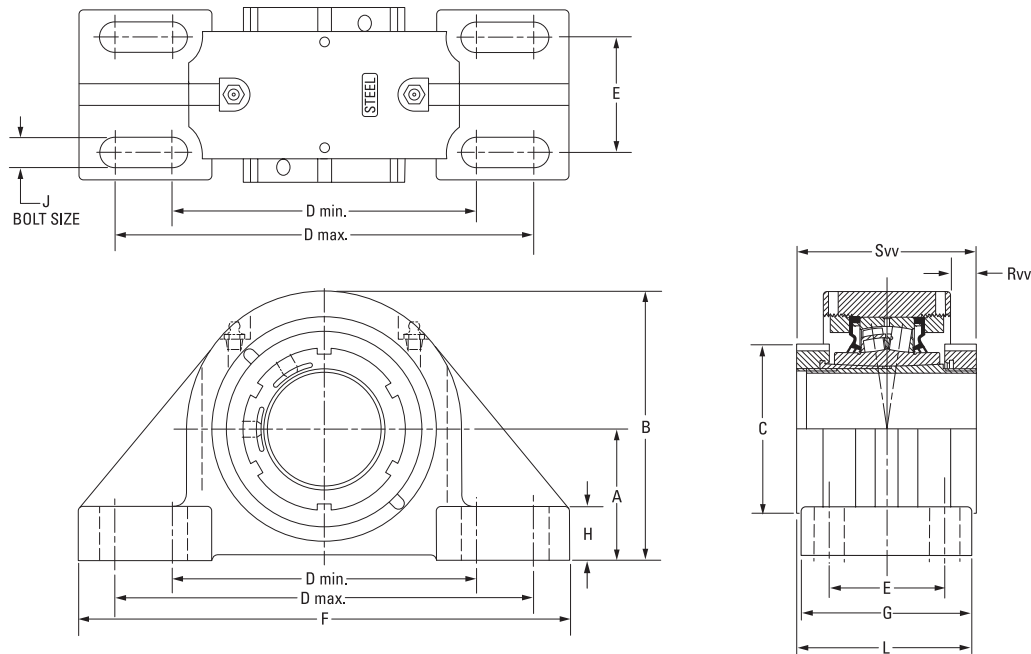

Bearing Part No. ⁽¹⁾	Shaft Dia.	Bearing No.	A	B	C	D min.	D max.	E	F	G	H	J	L	Rvv	Svv	Wt.
	mm in.		mm in.	mm in.	mm in.	mm in.	mm in.	mm in.	mm in.	mm in.	mm in.	mm in.	mm in.	mm in.	mm in.	kg lbs.
QVVPK15V060S	60 mm	22215	88.9 3.50	176.0 6.83	94.0 3.70	230.1 9.06	265.2 10.44	69.9 2.75	330.2 13.00	108.0 4.25	39.1 1.54	20 ¾	105.9 4.17	12.6 0.51	103.9 4.09	13.2 29
QVVPK15V207S	2 7/16 in.															
QVVPK15V208S	2 1/2 in.															
QVVPK15V065S	65 mm	22217	101.6 4.00	201.2 7.92	106.4 4.19	274.6 10.81	309.6 12.19	76.2 3.00	381.0 15.00	120.7 4.75	38.1 1.50	20 ¾	113.5 4.47	8.64 0.34	106.2 4.18	16.8 37
QVVPK17V211S	2 11/16 in.															
QVVPK17V212S	2 ¾ in.															
QVVPK17V070S	70 mm	22220	127.0 5.00	240.0 9.44	124.5 4.90	317.5 12.50	355.6 14.00	88.9 3.50	425.5 16.75	139.7 5.50	41.4 1.63	24 7/8	128.8 5.07	8.9 0.35	117.6 4.63	31.8 70
QVVPK20V303S	3 3/16 in.															
QVVPK20V304S	3 1/4 in.															
QVVPK20V080S	80 mm	22222	146.1 5.75	273.8 10.78	139.7 5.50	354.1 13.94	395.2 15.56	101.6 4.00	469.9 18.50	158.8 6.25	45.7 1.80	24 1	138.4 5.45	14.5 0.57	130.3 5.13	39.5 87
QVVPK20V085S	85 mm															
QVVPK20V307S	3 7/16 in.															
QVVPK20V308S	3 1/2 in.	22226	155.7 6.13	283.2 11.15	174.8 6.88	387.4 15.25	425.5 16.75	108.0 4.25	514.4 20.25	171.5 6.75	50.8 2.00	24 1	175.3 6.90	31.5 1.24	178.3 7.02	61.7 136
QVVPK20V090S	90 mm															
QVVPK22V311S	3 11/16 in.															
QVVPK22V312S	3 3/4 in.															
QVVPK22V100S	100 mm															
QVVPK22V315S	3 15/16 in.															
QVVPK22V400S	4 in.															
QVVPK26V110S	110 mm															
QVVPK26V407S	4 7/16 in.															
QVVPK26V408S	4 1/2 in.															
QVVPK26V115S	115 mm															

⁽¹⁾Double-nut (QVV) part number shown. Single-nut (QV) version available upon request.

SPHERICAL ROLLER BEARING SOLID-BLOCK HOUSED UNITS

V-LOCK SERIES • QVF AND QVVF SQUARE FLANGE BLOCKS – STRAIGHT BORE EQUIVALENT

QVF AND QVVF SQUARE FLANGE BLOCKS – STRAIGHT BORE EQUIVALENT

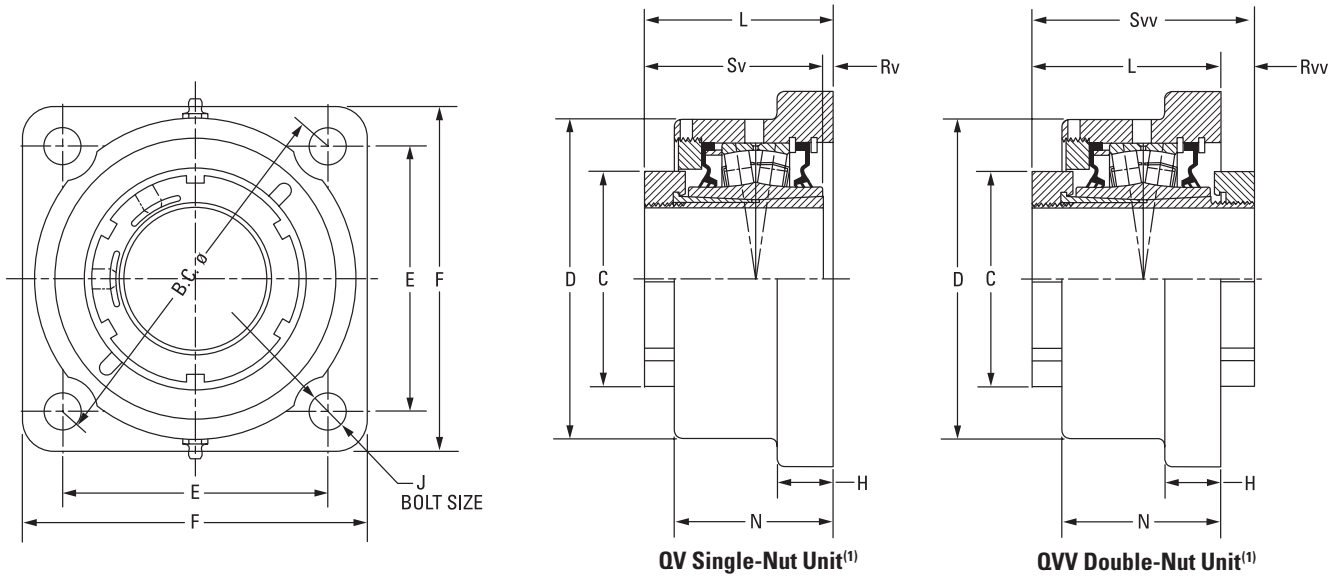

Bearing Part No. ⁽¹⁾⁽²⁾	Shaft Dia.	Bearing No.	C	D	E	B.C.	F	H	J	L FIX	L EXP	N	Rv ⁽¹⁾	Rvv	Sv ⁽¹⁾	Svv	Wt.
	mm in.		mm in.	mm in.	mm in.	mm in.	mm in.	mm in.	mm in.	mm in.	mm in.	mm in.	mm in.	mm in.	mm in.	mm in.	kg lbs.
QVF11V115S	1 15/16 in.	22211	75.9	120.7	111.3	157.0	139.7	22.4	12	84.1	86.1	65.0	4.1	18.3	79.8	102.1	5.0
QVF11V200S	2 in.		2.99	4.75	4.38	6.18	5.50	0.88	1/2	3.31	3.39	2.56	0.16	0.72	3.14	4.02	11
QVF11V050S	50 mm																
QVF12V203S	2 3/16 in.	22212	80.3	130.3	124.0	175.0	157.2	25.4	16	84.3	86.4	66.8	4.6	17.8	79.8	102.1	6.4
QVF12V204S	2 1/4 in.		3.16	5.13	4.88	6.89	6.19	1.00	5/8	3.32	3.40	2.63	0.18	0.70	3.14	4.02	14
QVF12V055S	55 mm																
QVF14V060S	60 mm	22214	94.0	146.1	136.7	193.0	168.4	25.4	16	85.1	87.1	72.4	4.1	16.0	81.0	101.3	7.7
QVF14V207S	2 7/16 in.		3.70	5.75	5.38	7.60	6.63	1.00	5/8	3.35	3.43	2.85	0.16	0.63	3.19	3.99	17
QVF14V208S	2 1/2 in.																
QVF14V065S	65 mm																
QVF16V211S	2 11/16 in.	22216	106.4	168.9	152.4	215.4	189.0	26.9	20	87.6	89.7	75.7	4.1	16.3	83.6	103.6	10.4
QVF16V212S	2 3/4 in.		4.19	6.65	6.00	8.48	7.44	1.06	3/4	3.45	3.53	2.98	0.16	0.64	3.29	4.08	23
QVF16V070S	70 mm																
QVF16V215S	2 15/16 in.																
QVF16V300S	3 in.																
QVF16V075S	75 mm																
QVF19V303S	3 3/16 in.	22219	124.5	193.8	177.8	251.7	219.2	33.3	20	98.3	100.3	84.1	4.6	15.7	93.7	114.0	15.9
QVF19V304S	3 1/4 in.		4.90	7.63	7.00	9.91	8.63	1.31	3/4	3.87	3.95	3.31	0.18	0.62	3.69	4.49	35
QVF19V080S	80 mm																
QVF19V085S	85 mm																
QVF19V307S	3 7/16 in.																
QVF19V308S	3 1/2 in.																
QVF19V090S	90 mm																
QVF22V311S	3 11/16 in.	22222	139.7	224.0	196.9	278.4	253.2	38.1	24	114.0	116.1	103.1	9.1	12.7	104.9	126.7	24.9
QVF22V312S	3 3/4 in.		5.50	8.82	7.75	10.96	9.97	1.50	7/8	4.49	4.57	4.06	0.36	0.50	4.13	4.99	55
QVF22V100S	100 mm																
QVF22V315S	3 15/16 in.																
QVF22V400S	4 in.																
QVF26V110S	110 mm	22226	174.8	256.8	222.3	314.5	276.4	38.1	24	140.5	142.7	106.9	7.4	37.8	147.8	178.3	28.6
QVF26V407S	4 7/16 in.		6.88	10.11	8.75	12.38	10.88	1.50	7/8	5.53	5.62	4.21	0.29	1.49	5.82	7.02	63
QVF26V408S	4 1/2 in.																
QVF26V115S	115 mm																

⁽¹⁾Bearing part numbers use QV to designate single-nut units (uses Rv and Sv dimensions) and QVV to designate double-nut units (uses Rvv and Svv dimensions).

⁽²⁾Single-nut (QV) part number shown. Double-nut (QVV) version available upon request.

SPHERICAL ROLLER BEARING SOLID-BLOCK HOUSED UNITS

V-LOCK SERIES • QVFB AND QVVFB FLANGE BLOCKS – TAPERED ADAPTER EQUIVALENT

QVFB AND QVVFB FLANGE BLOCKS – TAPERED ADAPTER EQUIVALENT

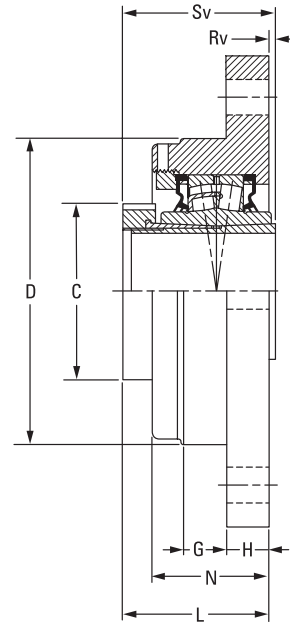
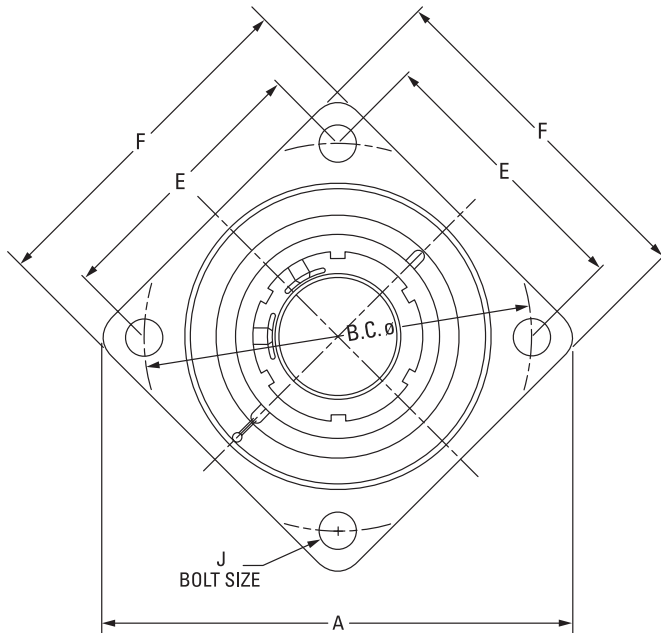

QV Single-Nut Unit⁽¹⁾

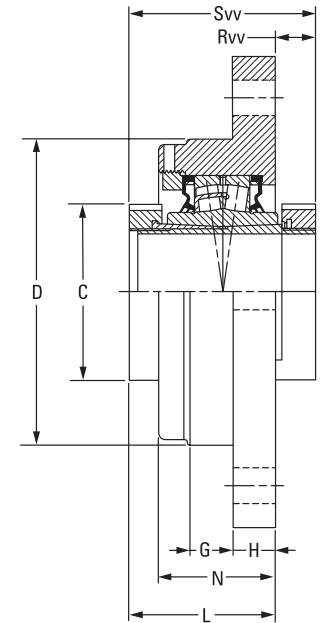

QVV Double-Nut Unit⁽¹⁾

Bearing Part No. ⁽¹⁾⁽²⁾	Shaft Dia.	Bearing No.	A	B.C.	C	D	E	F	G	H	J	L	N	Rv ⁽¹⁾	Rvv	Sv ⁽¹⁾	Svv	Wt.
	mm in.		mm in.	mm in.	mm in.	mm in.	mm in.	mm in.	mm in.	mm in.	mm in.	mm in.	mm in.	mm in.	mm in.	mm in.	mm in.	kg lbs.
QVFB15V060S	60 mm	22215	255.0 10.04	215.1 8.47	94.0 3.70	169.9 6.69	152.4 6.00	192.0 7.56	25.4 1.00	23.9 0.94	16 5/8	81.5 3.21	64.8 2.55	0.8 0.03	22.4 0.88	82.6 3.25	103.9 4.09	11.3 25
QVFB15V207S	2 7/16 in.																	
QVFB15V208S	2 1/2 in.																	
QVFB15V065S	65 mm	22217	282.4 11.12	240.0 9.45	106.4 4.19	190.0 7.48	169.7 6.68	212.1 8.35	25.4 1.00	25.4 1.00	16 5/8	83.8 3.30	69.9 2.75	1.0 0.04	22.4 0.88	84.6 3.33	106.2 4.18	13.6 30
QVFB17V211S	2 11/16 in.																	
QVFB17V212S	2 3/4 in.																	
QVFB17V070S	70 mm	22220	330.2 13.00	279.9 11.02	124.5 4.90	230.1 9.06	197.9 7.79	247.9 9.76	31.8 1.25	28.7 1.13	20 3/4	106.7 4.20	94.2 3.71	11.4 0.45	10.9 0.43	95.3 3.75	117.3 4.62	18.1 40
QVFB20V303S	3 3/16 in.																	
QVFB20V304S	3 1/4 in.																	
QVFB20V080S	80 mm	22222	367.0 14.45	309.9 12.20	139.7 5.50	255.0 10.04	219.2 8.63	274.3 10.80	44.5 1.75	26.4 1.04	20 3/4	112.0 4.41	101.1 3.98	7.4 0.29	14.7 0.58	104.9 4.13	126.7 4.99	27.2 60
QVFB20V085S	85 mm																	
QVFB20V307S	3 7/16 in.																	
QVFB20V308S	3 1/2 in.	22226	416.1 16.38	355.1 13.98	174.8 6.88	290.1 11.42	251.0 9.88	298.5 11.75	41.9 1.65	32.0 1.26	24 7/8	148.3 5.84	114.3 4.50	0.5 0.02	30.0 1.18	147.8 5.82	178.3 7.02	42.6 94
QVFB20V090S	90 mm																	
QVFB22V311S	3 11/16 in.																	
QVFB22V312S	3 3/4 in.																	
QVFB22V100S	100 mm																	
QVFB22V315S	3 15/16 in.																	
QVFB22V400S	4 in.																	
QVFB26V110S	110 mm																	
QVFB26V407S	4 7/16 in.																	
QVFB26V408S	4 1/2 in.																	
QVFB26V115S	115 mm																	

⁽¹⁾Bearing part numbers use QV to designate single-nut units (uses Rv and Sv dimensions) and QVV to designate double-nut units (uses Rvv and Sv dimensions).

⁽²⁾Single-nut (QV) part number shown. Double-nut (QVV) version available upon request.

SPHERICAL ROLLER BEARING SOLID-BLOCK HOUSED UNITS

V-LOCK SERIES • QVFC AND QVVFC PILOTED FLANGE CARTRIDGES – TAPERED ADAPTER EQUIVALENT

QVFC AND QVVFC PILOTED FLANGE CARTRIDGES – TAPERED ADAPTER EQUIVALENT

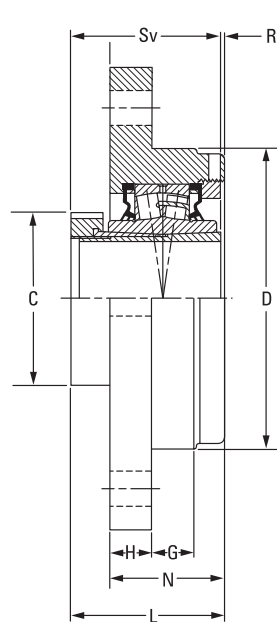
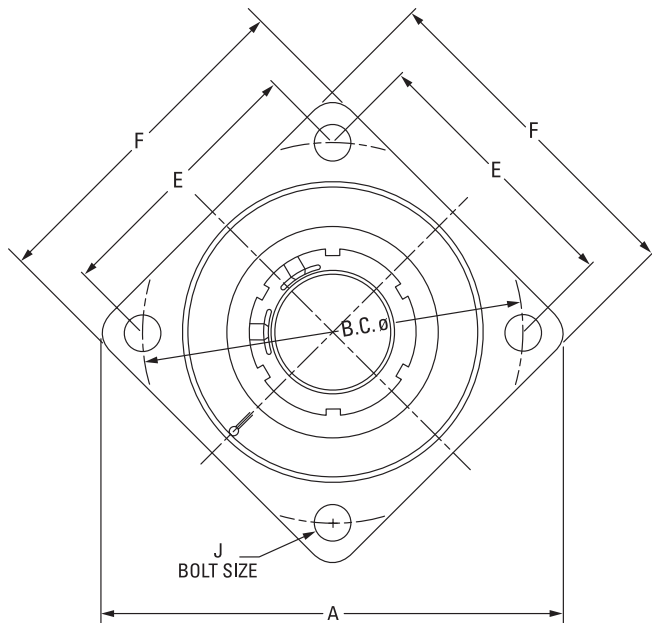

QV Single-Nut Unit⁽¹⁾

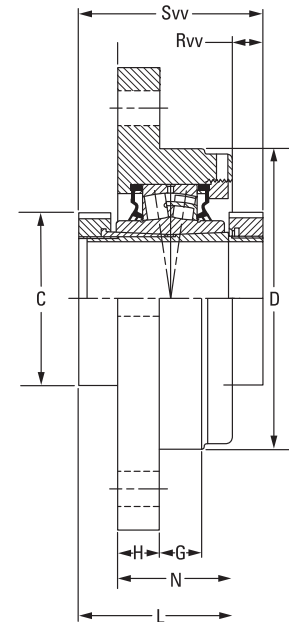

QVV Double-Nut Unit⁽¹⁾

Bearing Part No. ⁽¹⁾⁽²⁾	Shaft Dia.	Bearing No.	A	B.C.	C	D ⁽³⁾	E	F	G	H	J	L	N	Rv ⁽¹⁾	Rvv	Sv ⁽¹⁾	Svv	Wt.
			mm in.	mm in.	mm in.	mm in.	mm in.	mm in.	mm in.	mm in.	mm in.	mm in.	mm in.	mm in.	mm in.	mm in.	mm in.	mm in.
QVFC15V060S	60 mm	22215	255.0 10.04	215.1 8.47	94.0 3.70	169.9 6.690	152.4 6.00	192.0 7.56	25.4 1.00	23.9 0.94	16 5/8	87.1 3.43	64.8 2.55	4.6 0.18	16.8 0.66	82.6 3.25	103.9 4.09	11.3 25
QVFC15V207S	2 7/16 in.																	
QVFC15V208S	2 1/2 in.																	
QVFC15V065S	65 mm	22217	282.4 11.12	240.0 9.45	106.4 4.19	190.0 7.480	169.7 6.68	212.1 8.35	25.4 1.00	25.4 1.00	16 5/8	91.7 3.61	69.9 2.75	6.6 0.26	14.5 0.57	84.6 3.33	106.2 4.18	13.6 30
QVFC17V211S	2 11/16 in.																	
QVFC17V212S	2 3/4 in.																	
QVFC17V070S	70 mm	22220	330.2 13.00	279.9 11.02	124.5 4.90	230.1 9.060	197.9 7.79	247.9 9.76	31.8 1.25	28.7 1.13	20 3/4	105.2 4.14	94.2 3.71	9.7 0.38	12.4 0.49	95.3 3.75	117.3 4.62	18.1 40
QVFC20V303S	3 3/16 in.																	
QVFC20V304S	3 1/4 in.																	
QVFC20V080S	80 mm	22222	367.0 14.45	309.9 12.20	139.7 5.50	255.0 10.040	219.2 8.63	274.3 10.80	44.5 1.75	26.4 1.04	20 3/4	112.8 4.44	101.1 3.98	8.1 0.32	5.8 0.23	104.9 4.13	126.7 4.99	27.2 60
QVFC20V085S	85 mm																	
QVFC20V307S	3 7/16 in.																	
QVFC20V308S	3 1/2 in.	22226	416.1 16.38	355.1 13.98	174.8 6.88	290.0 11.417	251.0 9.88	298.5 11.75	41.9 1.65	32.0 1.26	24 7/8	144.3 5.68	114.3 4.50	3.6 0.14	34.0 1.34	147.8 5.82	178.3 7.02	42.6 94
QVFC20V090S	90 mm																	
QVFC22V311S	3 11/16 in.																	
QVFC22V312S	3 3/4 in.																	
QVFC22V100S	100 mm																	
QVFC22V315S	3 15/16 in.																	
QVFC22V400S	4 in.																	
QVFC26V110S	110 mm																	
QVFC26V407S	4 7/16 in.																	
QVFC26V408S	4 1/2 in.																	
QVFC26V115S	115 mm																	

⁽¹⁾Bearing part numbers use QV to designate single-nut units (uses Rv and Sv dimensions) and QVV to designate double-nut units (uses Rvv and Svv dimensions).

⁽²⁾Single-nut (QV) part number shown. Double-nut (QVV) version available upon request.

⁽³⁾Pilot tolerance: +0/-0.05 mm (+0/-0.002 in.).

SPHERICAL ROLLER BEARING SOLID-BLOCK HOUSED UNITS

V-LOCK SERIES • QVFL AND QVVFL SQUARE FLANGE BLOCKS – STRAIGHT BORE EQUIVALENT

QVFL AND QVVFL SQUARE FLANGE BLOCKS – STRAIGHT BORE EQUIVALENT

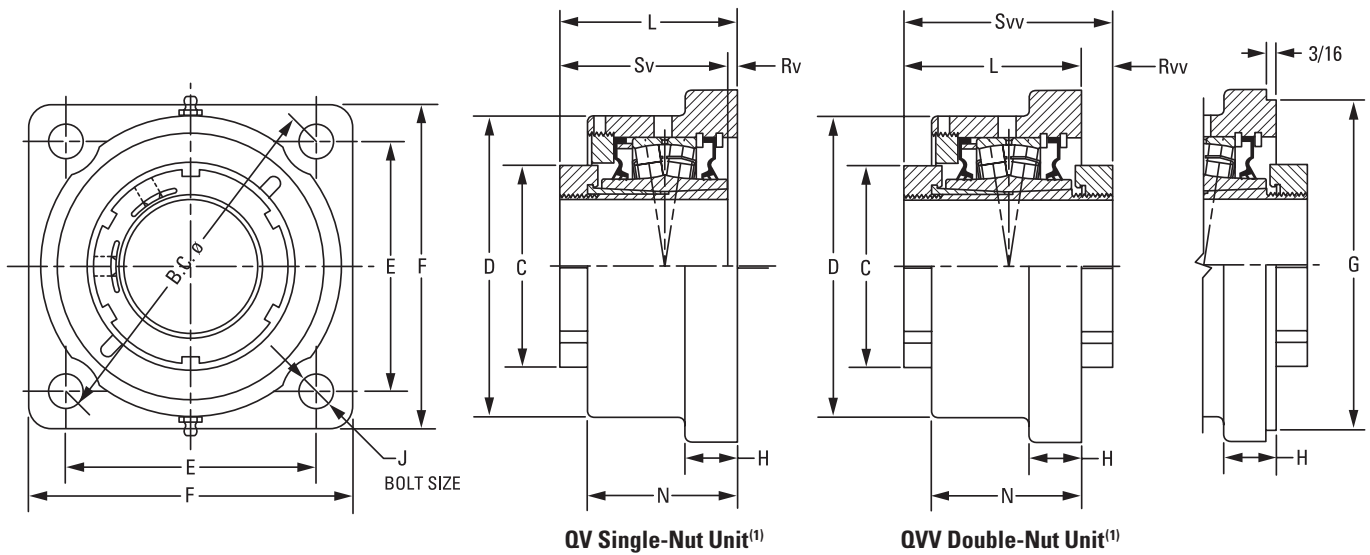

Bearing Part No. ⁽¹⁾⁽²⁾	Shaft Dia.	Bearing No.	C	D	E	B.C.	F	G ⁽³⁾⁽⁴⁾⁽⁵⁾	H	J	L _{FIX}	L _{EXP}	N	Rv ⁽¹⁾	Rvv	Sv ⁽¹⁾	Svv	Wt.
	mm in.		mm in.	mm in.	mm in.	mm in.	mm in.	mm in.	mm in.	mm in.	mm in.	mm in.	mm in.	mm in.	mm in.	mm in.	mm in.	kg lbs.
QVFL11V115S	1 15/16 in.	22211	75.9	115.3	103.4	146.1	131.8	N/A	23.1	12	82.6	84.6	61.2	2.5	19.8	79.8	102.1	5.0
QVFL11V200S	2 in.		2.99	4.54	4.07	5.75	5.19		0.91	1/2	3.25	3.33	2.41	0.10	0.78	3.14	4.02	11
QVFL11V050S	50 mm																	
QVFL12V203S	2 3/16 in.	22212	80.3	130.3	114.6	162.1	149.4	N/A	19.1	16	84.3	86.4	66.8	4.6	17.8	79.8	102.1	6.4
QVFL12V204S	2 1/4 in.		3.16	5.13	4.51	6.38	5.88		0.75	5/8	3.32	3.40	2.63	0.18	0.70	3.14	4.02	14
QVFL12V055S	55 mm																	
QVFL14V060S	60 mm	22214	94.0	146.1	121.2	171.5	157.2	N/A	25.4	16	86.1	88.1	72.6	5.1	15.2	81.0	101.3	7.7
QVFL14V207S	2 7/16 in.		3.70	5.75	4.77	6.75	6.19		1.00	5/8	3.39	3.47	2.86	0.20	0.60	3.19	3.99	17
QVFL14V208S	2 1/2 in.																	
QVFL14V065S	65 mm	22216	106.4	168.4	141.2	200.2	182.6	N/A	26.9	20	86.9	88.9	74.4	3.3	17.0	83.6	103.6	10.4
QVFL16V211S	2 11/16 in.		4.19	6.63	5.56	7.88	7.19		1.06	3/4	3.42	3.50	2.93	0.13	0.67	3.29	4.08	23
QVFL16V212S	2 3/4 in.																	
QVFL16V070S	70 mm	22219	124.5	193.8	170.7	241.3	212.9	187.33	32.5	20	97.3	99.3	86.4	3.6	17.0	93.7	114.0	15.9
QVFL16V215S	2 15/16 in.		4.90	7.63	6.72	9.50	8.38	7.375	1.28	3/4	3.83	3.91	3.40	0.14	0.67	3.69	4.49	35
QVFL16V300S	3 in.																	
QVFL16V075S	75 mm	22222	139.7	229.6	193.0	273.1	241.3	215.90	38.1	24	116.8	118.9	104.6	11.9	9.9	104.9	126.7	24.9
QVFL19V303S	3 3/16 in.		4.90	7.63	6.72	9.50	8.38	7.375	1.28	3/4	3.83	3.91	3.40	0.14	0.67	3.69	4.49	35
QVFL19V304S	3 1/4 in.																	
QVFL19V080S	80 mm	22222	139.7	229.6	193.0	273.1	241.3	215.90	38.1	24	116.8	118.9	104.6	11.9	9.9	104.9	126.7	24.9
QVFL19V085S	85 mm		4.90	7.63	6.72	9.50	8.38	7.375	1.28	3/4	3.83	3.91	3.40	0.14	0.67	3.69	4.49	35
QVFL19V307S	3 7/16 in.																	
QVFL19V308S	3 1/2 in.	22222	139.7	229.6	193.0	273.1	241.3	215.90	38.1	24	116.8	118.9	104.6	11.9	9.9	104.9	126.7	24.9
QVFL19V090S	90 mm		4.90	7.63	6.72	9.50	8.38	7.375	1.28	3/4	3.83	3.91	3.40	0.14	0.67	3.69	4.49	35
QVFL22V311S	3 11/16 in.																	
QVFL22V312S	3 3/4 in.	22222	139.7	229.6	193.0	273.1	241.3	215.90	38.1	24	116.8	118.9	104.6	11.9	9.9	104.9	126.7	24.9
QVFL22V100S	100 mm		5.50	9.04	7.60	10.75	9.50	8.500	1.50	1	4.60	4.68	4.12	0.47	0.39	4.13	4.99	55
QVFL22V315S	3 15/16 in.																	
QVFL22V400S	4 in.																	

⁽¹⁾ Bearing part numbers use QV to designate single-nut units (uses Rv and Sv dimensions) and QVV to designate double-nut units (uses Rvv and Svv dimensions).

⁽²⁾ Single-nut (QV) part number shown. Double-nut (QVV) version available upon request.

⁽³⁾ Pilot tolerance: +0/-0.08 mm (+0/-0.003 in.).

⁽⁴⁾ Add (p) to the end of the housing designation in the part number to order with pilot using G dimension.

⁽⁵⁾ Piloted flange blocks will be quoted (price and delivery) upon request. For optional spigot on flange side, insert the letter P as seen in the following example: QMFP**J***S.

SPHERICAL ROLLER BEARING SOLID-BLOCK HOUSED UNITS

V-LOCK SERIES • QVFX AND QVVFX 5000 SERIES SQUARE FLANGE BLOCKS – STRAIGHT BORE EQUIVALENT

QVFX AND QVVFX 5000 SERIES SQUARE FLANGE BLOCKS – STRAIGHT BORE EQUIVALENT

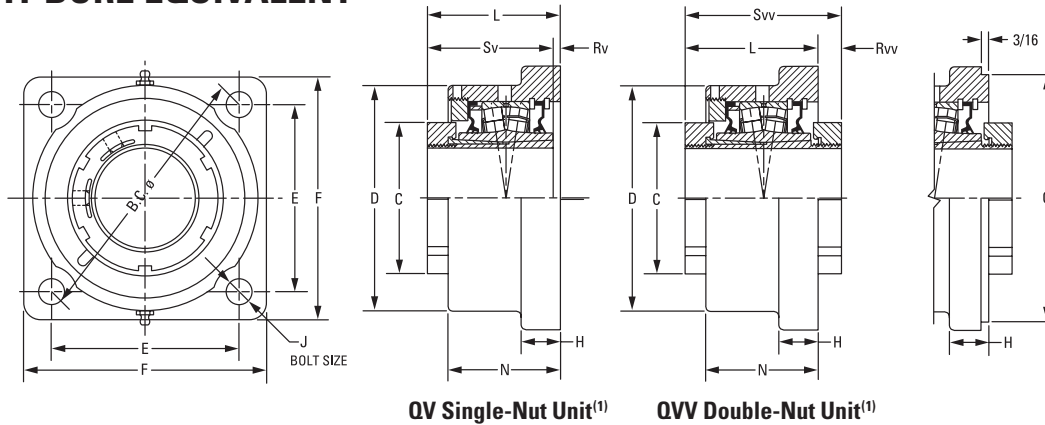

QV Single-Nut Unit⁽¹⁾

QVV Double-Nut Unit⁽¹⁾

Bearing Part No. ⁽¹⁾⁽²⁾	Shaft Dia.	Bearing No.	C	D	E	B.C.	F	G ⁽³⁾⁽⁴⁾⁽⁵⁾	H	J	L FIX	L EXP	N	Rv ⁽¹⁾	Rvv	Sv ⁽¹⁾	Svv	Wt.
			mm in.	mm in.	mm in.	mm in.	mm in.	mm in.	mm in.	mm in.	mm in.	mm in.	mm in.	mm in.	mm in.	mm in.	mm in.	mm in.
QVFX11V115S	1 15/16 in.	22211	75.9	120.7	103.6	146.1	134.9	111.13	22.4	12	84.1	86.1	65.0	4.1	18.3	79.8	102.1	5.0
QVFX11V200S	2 in.		2.99	4.75	4.08	5.75	5.31	4.375	0.88	1/2	3.31	3.39	2.56	0.16	0.72	3.14	4.02	11
QVFX11V050S	50 mm																	
QVFX12V203S	2 3/16 in.	22212	80.3	130.3	114.3	161.5	149.4	127.00	25.4	16	84.3	86.4	66.8	4.6	17.5	79.8	102.1	6.4
QVFX12V204S	2 1/4 in.		3.16	5.13	4.50	6.36	5.88	5.000	1.00	5/8	3.32	3.40	2.63	0.18	0.69	3.14	4.02	14
QVFX12V055S	55 mm																	
QVFX14V060S	60 mm	22214	94.0	146.1	127.8	180.8	157.2	138.13	25.4	16	85.1	87.4	72.4	4.1	16.0	81.0	101.3	7.7
QVFX14V207S	2 7/16 in.		3.70	5.75	5.03	7.12	6.19	5.438	1.00	5/8	3.35	3.44	2.85	0.16	0.63	3.19	3.99	17
QVFX14V208S	2 1/2 in.																	
QVFX14V065S	65 mm	22216	106.4	168.9	152.7	215.9	189.0	160.35	26.9	20	87.6	89.7	76.2	4.1	16.3	83.6	103.6	10.4
QVFX16V211S	2 11/16 in.		4.19	6.65	6.01	8.50	7.44	6.313	1.06	3/4	3.45	3.53	3.00	0.16	0.64	3.29	4.08	23
QVFX16V212S	2 3/4 in.																	
QVFX16V070S	70 mm	22219	124.5	193.8	170.7	241.3	212.6	187.33	33.3	20	98.3	100.6	84.1	4.8	15.7	93.7	114.0	15.9
QVFX16V215S	2 15/16 in.		4.90	7.63	6.72	9.50	8.37	7.375	1.31	3/4	3.87	3.96	3.31	0.19	0.62	3.69	4.49	35
QVFX16V300S	3 in.																	
QVFX16V075S	75 mm	22222	139.7	215.9	211.1	298.5	268.2	225.43	38.1	24	114.0	116.3	100.6	9.4	12.7	104.9	126.7	24.9
QVFX19V303S	3 3/16 in.		5.50	8.50	8.31	11.75	10.56	8.875	1.50	1	4.49	4.58	3.96	0.37	0.50	4.13	4.99	55
QVFX19V304S	3 1/4 in.																	
QVFX19V080S	80 mm	22226	174.8	256.5	163.6	327.2	384.3	263.53	38.1	24	140.5	142.7	106.9	7.4	37.8	147.8	178.3	49.0
QVFX19V085S	85 mm		6.88	10.10	6.44 ⁽⁶⁾	12.88 ⁽⁶⁾	15.13	10.375	1.50	1 ⁽⁶⁾	5.53	5.62	4.21	0.29	1.49	5.82	7.02	108
QVFX19V307S	3 7/16 in.																	
QVFX19V308S	3 1/2 in.	22228	189.7	284.2	177.8	355.6	419.1	284.18	38.1	24	166.1	168.1	138.4	18.3	12.2	147.8	178.3	52.2
QVFX19V090S	90 mm		7.47	11.19	7.00 ⁽⁶⁾	14.00 ⁽⁶⁾	16.50	11.188	1.50	1 1/8 ⁽⁶⁾	6.54	6.62	5.45	0.72	0.48	5.82	7.02	115
QVFX22V311S	3 11/16 in.																	
QVFX22V312S	3 3/4 in.	22228	189.7	284.2	177.8	355.6	419.1	284.18	38.1	24	166.1	168.1	138.4	18.3	12.2	147.8	178.3	52.2
QVFX22V100S	100 mm		7.47	11.19	7.00 ⁽⁶⁾	14.00 ⁽⁶⁾	16.50	11.188	1.50	1 1/8 ⁽⁶⁾	6.54	6.62	5.45	0.72	0.48	5.82	7.02	115
QVFX22V315S	3 15/16 in.																	
QVFX22V400S	4 in.	22226	174.8	256.5	163.6	327.2	384.3	263.53	38.1	24	140.5	142.7	106.9	7.4	37.8	147.8	178.3	49.0
QVFX26V110S ⁽⁶⁾	110 mm		6.88	10.10	6.44 ⁽⁶⁾	12.88 ⁽⁶⁾	15.13	10.375	1.50	1 ⁽⁶⁾	5.53	5.62	4.21	0.29	1.49	5.82	7.02	108
QVFX26V407S ⁽⁶⁾	4 7/16 in.																	
QVFX26V408S ⁽⁶⁾	4 1/2 in.	22228	189.7	284.2	177.8	355.6	419.1	284.18	38.1	24	166.1	168.1	138.4	18.3	12.2	147.8	178.3	52.2
QVFX26V115S ⁽⁶⁾	115 mm		7.47	11.19	7.00 ⁽⁶⁾	14.00 ⁽⁶⁾	16.50	11.188	1.50	1 1/8 ⁽⁶⁾	6.54	6.62	5.45	0.72	0.48	5.82	7.02	115
QVFX28V125S ⁽⁶⁾	125 mm																	
QVFX28V415S ⁽⁶⁾	4 15/16 in.	22228	189.7	284.2	177.8	355.6	419.1	284.18	38.1	24	166.1	168.1	138.4	18.3	12.2	147.8	178.3	52.2
QVFX28V500S ⁽⁶⁾	5 in.		7.47	11.19	7.00 ⁽⁶⁾	14.00 ⁽⁶⁾	16.50	11.188	1.50	1 1/8 ⁽⁶⁾	6.54	6.62	5.45	0.72	0.48	5.82	7.02	115
QVFX28V130S ⁽⁶⁾	130 mm																	

⁽¹⁾ Bearing part numbers use QV to designate single-nut units (uses Rv and Sv dimensions) and QVV to designate double-nut units (uses Rvv and Sv dimensions).

⁽²⁾ Single-nut (QV) part number shown. Double-nut (QVV) version available upon request.

⁽³⁾ Pilot tolerance: +0/-0.05 mm (+0/-0.002 in.).

⁽⁴⁾ Add (p) to the end of the housing designation in the part number to order with pilot using G dimension.

⁽⁵⁾ Piloted flange blocks will be quoted (price and delivery) upon request. For optional spigot on flange side, insert the letter P as seen in the following example: QMFP**J***S.

⁽⁶⁾ Six-bolt round housing.

QVFK AND QVVFK 9000 SERIES SQUARE FLANGE BLOCKS – TAPERED BORE EQUIVALENT

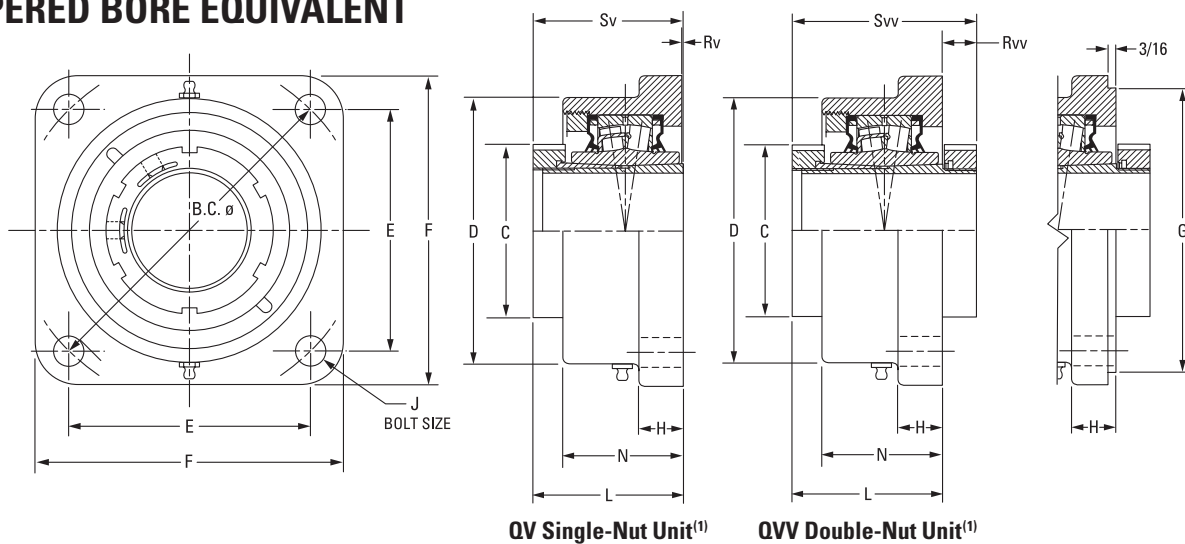

Bearing Part No. ⁽¹⁾⁽²⁾	Shaft Dia.	Bearing No.	C	D	E	B.C.	F	G ⁽³⁾⁽⁴⁾⁽⁵⁾	H	J	L _{FIX}	L _{EXP}	N	Rv ⁽¹⁾	Rvv	Sv ⁽¹⁾	Svv	Wt.
	mm in.		mm in.	mm in.	mm in.	mm in.	mm in.	mm in.	mm in.	mm in.	mm in.	mm in.	mm in.	mm in.	mm in.	mm in.	mm in.	kg lbs.
QVFK11V115S	1 15/16 in.	22211	75.9	130.3	114.3	161.5	149.4	127.00	25.4	16	87.1	88.4	66.8	7.4	15.0	79.8	102.1	5.0
QVFK11V200S	2 in.		2.99	5.13	4.50	6.36	5.88	5.000	1.00	5/8	3.43	3.48	2.63	0.29	0.59	3.14	4.02	11
QVFK11V050S	50 mm																	
QVFK13V203S	2 3/16 in.	22213	80.3	146.1	127.8	180.8	157.2	138.13	25.4	16	92.2	94.2	72.4	6.9	15.5	85.3	107.7	6.4
QVFK13V204S	2 1/4 in.		3.16	5.75	5.03	7.12	6.19	5.438	1.00	5/8	3.63	3.71	2.85	0.27	0.61	3.36	4.24	14
QVFK13V055S	55 mm																	
QVFK15V060S	60 mm	22215	94.0	168.9	152.7	215.9	189.0	160.35	26.9	20	92.5	94.5	76.2	9.9	11.4	82.6	103.9	7.7
QVFK15V207S	2 7/16 in.		3.70	6.65	6.01	8.50	7.44	6.313	1.06	3/4	3.64	3.72	3.00	0.39	0.45	3.25	4.09	17
QVFK15V208S	2 1/2 in.																	
QVFK15V065S	65 mm	22217	106.4	193.8	170.7	241.3	212.9	187.33	33.3	20	92.5	101.1	84.1	14.5	7.1	84.6	106.2	10.4
QVFK17V211S	2 11/16 in.		4.19	7.63	6.72	9.50	8.38	7.375	1.31	3/4	3.64	3.98	3.31	0.57	0.28	3.33	4.18	23
QVFK17V212S	2 3/4 in.																	
QVFK17V070S	70 mm	22220	124.5	215.9	211.1	298.5	268.2	225.43	38.1	24	113.3	115.3	103.1	18.0	4.1	95.3	117.3	15.9
QVFK17V215S	2 15/16 in.		4.90	8.50	8.31	11.75	10.56	8.875	1.50	7/8	4.46	4.54	4.06	0.71	0.16	3.75	4.62	35
QVFK17V300S	3 in.																	
QVFK17V075S	75 mm	22222	139.7	256.5	168.7	327.2	384.3	263.53	31.8	24	117.3	119.4	106.9	12.4	9.7	104.9	126.7	24.9
QVFK20V303S	3 3/16 in.		5.50	10.10	6.64 ⁽⁶⁾	12.88 ⁽⁶⁾	15.13	10.375	1.25	1 ⁽⁶⁾	4.62	4.70	4.21	0.49	0.38	4.13	4.99	55
QVFK20V304S	3 1/4 in.																	
QVFK20V080S	80 mm	22226	174.8	284.2	177.8	355.6	419.1	124.18	38.1	28.6	164.6	166.6	135.1	11.7	13.7	147.8	178.3	49.0
QVFK20V085S	85 mm		4.90	8.50	8.31	11.75	10.56	8.875	1.50	7/8	4.46	4.54	4.06	0.71	0.16	3.75	4.62	35
QVFK20V307S	3 7/16 in.																	
QVFK20V308S	3 1/2 in.	22226	174.8	284.2	177.8	355.6	419.1	124.18	38.1	28.6	164.6	166.6	135.1	11.7	13.7	147.8	178.3	49.0
QVFK20V090S	90 mm		4.90	8.50	8.31	11.75	10.56	8.875	1.50	7/8	4.46	4.54	4.06	0.71	0.16	3.75	4.62	35
QVFK22V311S ⁽⁶⁾	3 11/16 in.																	
QVFK22V312S ⁽⁶⁾	3 3/4 in.	22222	139.7	256.5	168.7	327.2	384.3	263.53	31.8	24	117.3	119.4	106.9	12.4	9.7	104.9	126.7	24.9
QVFK22V100S ⁽⁶⁾	100 mm		5.50	10.10	6.64 ⁽⁶⁾	12.88 ⁽⁶⁾	15.13	10.375	1.25	1 ⁽⁶⁾	4.62	4.70	4.21	0.49	0.38	4.13	4.99	55
QVFK22V315S ⁽⁶⁾	3 15/16 in.																	
QVFK22V400S ⁽⁶⁾	4 in.	22226	174.8	284.2	177.8	355.6	419.1	124.18	38.1	28.6	164.6	166.6	135.1	11.7	13.7	147.8	178.3	49.0
QVFK26V110S ⁽⁶⁾	110 mm		6.88	11.19	7.00 ⁽⁶⁾	14.00 ⁽⁶⁾	16.50	4.89	1.50	1 1/8 ⁽⁶⁾	6.48	6.56	5.32	0.46	0.54	5.82	7.02	108
QVFK26V407S ⁽⁶⁾	4 7/16 in.																	
QVFK26V408S ⁽⁶⁾	4 1/2 in.	22226	174.8	284.2	177.8	355.6	419.1	124.18	38.1	28.6	164.6	166.6	135.1	11.7	13.7	147.8	178.3	49.0
QVFK26V115S ⁽⁶⁾	115 mm		6.88	11.19	7.00 ⁽⁶⁾	14.00 ⁽⁶⁾	16.50	4.89	1.50	1 1/8 ⁽⁶⁾	6.48	6.56	5.32	0.46	0.54	5.82	7.02	108

⁽¹⁾ Bearing part numbers use QV to designate single-nut units (uses Rv and Sv dimensions) and QVV to designate double-nut units (uses Rvv and Svv dimensions).

⁽²⁾ Single-nut (QV) part number shown. Double-nut (QVV) version available upon request.

⁽³⁾ Pilot tolerance: +0/-0.05 mm (+0/-0.002 in.).

⁽⁴⁾ Add (p) to the end of the housing designation in the part number to order with pilot using G dimension.

⁽⁵⁾ Piloted flange blocks will be quoted (price and delivery) upon request. For optional spigot on flange side, insert the letter P as seen in the following example: QMFP**J***S.

⁽⁶⁾ Six-bolt round housing.

SPHERICAL ROLLER BEARING SOLID-BLOCK HOUSED UNITS

V-LOCK SERIES • QVfy AND QVfy ROUND FLANGE BLOCKS – STRAIGHT BORE EQUIVALENT

QVfy AND QVfy ROUND FLANGE BLOCKS – STRAIGHT BORE EQUIVALENT

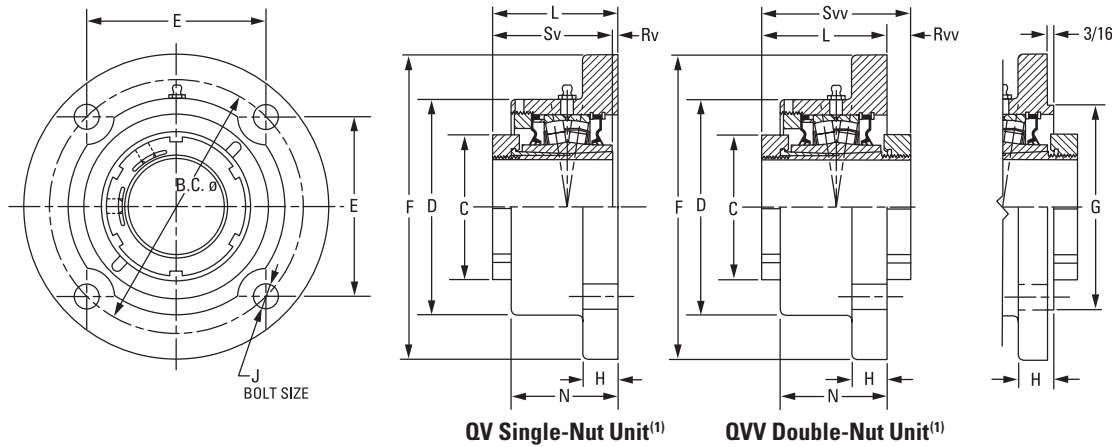

Bearing Part No. ⁽¹⁾⁽²⁾	Shaft Dia.	Bearing No.	C	D	E	B.C.	F	G ⁽³⁾⁽⁴⁾⁽⁵⁾	H	J	L _{FIX}	L _{EXP}	N	Rv ⁽¹⁾	Rvv	Sv ⁽¹⁾	Svv	Wt.
			mm in.	mm in.	mm in.	mm in.	mm in.	mm in.	mm in.	mm in.	mm in.	mm in.	mm in.	mm in.	mm in.	mm in.	mm in.	mm in.
QVfy11V115S	1 15/16 in.	22211	75.9	115.3	103.4	146.1	177.8	111.13	19.1	12	78.5	80.5	58.4	1.5	23.9	79.8	102.1	5.4
QVfy11V200S	2 in.		2.99	4.54	4.07	5.75	7.00	4.375	0.75	1/2	3.09	3.17	2.30	0.06	0.94	3.14	4.02	12
QVfy11V050S	50 mm																	
QVfy12V203S	2 3/16 in.	22212	80.3	130.3	114.6	162.1	196.9	127.00	19.1	16	80.0	82.0	62.0	0.3	22.1	79.8	102.1	6.8
QVfy12V204S	2 1/4 in.		3.16	5.13	4.51	6.38	7.75	5.000	0.75	5/8	3.15	3.23	2.44	0.01	0.87	3.14	4.02	15
QVfy12V055S	55 mm																	
QVfy14V060S	60 mm	22214	94.0	146.1	121.2	171.5	206.5	138.13	23.9	16	84.8	86.9	72.4	3.8	16.5	81.0	101.3	8.6
QVfy14V207S	2 7/16 in.		3.70	5.75	4.77	6.75	8.13	5.438	0.94	5/8	3.34	3.42	2.85	0.15	0.65	3.19	3.99	19
QVfy14V208S	2 1/2 in.																	
QVfy14V065S	65 mm	22216	106.4	168.4	141.2	200.2	241.3	160.35	23.9	20	88.4	90.4	76.2	4.8	15.2	83.6	103.6	12.7
QVfy16V211S	2 11/16 in.		4.19	6.63	5.56	7.88	9.50	6.313	0.94	3/4	3.48	3.56	3.00	0.19	0.60	3.29	4.08	28
QVfy16V212S	2 3/4 in.																	
QVfy16V070S	70 mm	22219	124.5	193.8	170.7	241.3	282.7	187.33	28.7	24	98.3	116.1	85.3	4.8	15.7	93.7	114.0	19.1
QVfy16V215S	2 15/16 in.		4.90	7.63	6.72	9.50	11.13	7.375	1.13	7/8	3.87	4.57	3.36	0.19	0.62	3.69	4.49	42
QVfy16V300S	3 in.																	
QVfy16V075S	75 mm	22222	139.7	222.5	193.0	273.1	320.8	N/A	28.7	24	115.3	117.3	103.1	10.4	11.4	104.9	126.7	29.9
QVfy19V303S	3 3/16 in.		5.50	8.76	7.60	10.75	12.63		1.13	1	4.54	4.62	4.06	0.41	0.45	4.13	4.99	66
QVfy19V304S	3 1/4 in.																	
QVfy19V080S	80 mm	22226	174.8	230.1	163.6	327.2	384.3	N/A	38.1	24	140.5	142.7	106.9	7.4	37.8	147.8	178.3	49.0
QVfy19V085S	85 mm		4.90	7.63	6.72	9.50	11.13	7.375	1.13	7/8	3.87	4.57	3.36	0.19	0.62	3.69	4.49	42
QVfy19V307S	3 7/16 in.																	
QVfy19V308S	3 1/2 in.	22228	190.0	284.2	177.8	355.6	419.1	N/A	38.1	24	166.1	168.1	138.4	18.3	12.2	147.8	178.3	52.2
QVfy19V090S	90 mm		5.50	8.76	7.60	10.75	12.63		1.13	1	4.54	4.62	4.06	0.41	0.45	4.13	4.99	66
QVfy22V311S	3 11/16 in.																	
QVfy22V312S	3 3/4 in.	22228	190.0	284.2	177.8	355.6	419.1	N/A	38.1	24	166.1	168.1	138.4	18.3	12.2	147.8	178.3	52.2
QVfy22V100S	100 mm		5.50	8.76	7.60	10.75	12.63		1.13	1	4.54	4.62	4.06	0.41	0.45	4.13	4.99	66
QVfy22V315S	3 15/16 in.																	
QVfy22V400S	4 in.	22228	190.0	284.2	177.8	355.6	419.1	N/A	38.1	24	166.1	168.1	138.4	18.3	12.2	147.8	178.3	52.2
QVfy26V110S ⁽⁶⁾	110 mm		5.50	8.76	7.60	10.75	12.63		1.13	1	4.54	4.62	4.06	0.41	0.45	4.13	4.99	66
QVfy26V407S ⁽⁶⁾	4 7/16 in.																	
QVfy26V408S ⁽⁶⁾	4 1/2 in.	22228	190.0	284.2	177.8	355.6	419.1	N/A	38.1	24	166.1	168.1	138.4	18.3	12.2	147.8	178.3	52.2
QVfy26V115S ⁽⁶⁾	115 mm		5.50	8.76	7.60	10.75	12.63		1.13	1	4.54	4.62	4.06	0.41	0.45	4.13	4.99	66
QVfy28V125S ⁽⁶⁾	125 mm																	
QVfy28V415S ⁽⁶⁾	4 15/16 in.	22228	190.0	284.2	177.8	355.6	419.1	N/A	38.1	24	166.1	168.1	138.4	18.3	12.2	147.8	178.3	52.2
QVfy28V500S ⁽⁶⁾	5 in.		5.50	8.76	7.60	10.75	12.63		1.13	1	4.54	4.62	4.06	0.41	0.45	4.13	4.99	66
QVfy28V130S ⁽⁶⁾	130 mm																	

⁽¹⁾ Bearing part numbers use QV to designate single-nut units (uses Rv and Sv dimensions) and QVV to designate double-nut units (uses Rvv and Sv dimensions).

⁽²⁾ Single-nut (QV) part number shown. Double-nut (QVV) version available upon request.

⁽³⁾ Pilot tolerance: +0/-0.05 mm (+0/-0.002 in.).

⁽⁴⁾ Add (p) to the end of the housing designation in the part number to order with pilot using G dimension.

⁽⁵⁾ Piloted flange blocks will be quoted (price and delivery) upon request. For optional spigot on flange side, insert the letter P as seen in the following example: QMFP**J***S.

⁽⁶⁾ Six-bolt round housing.

QVC AND QVVC PILOTED FLANGE CARTRIDGES – STRAIGHT BORE EQUIVALENT

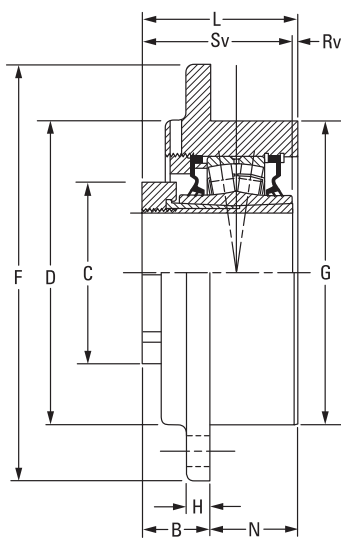
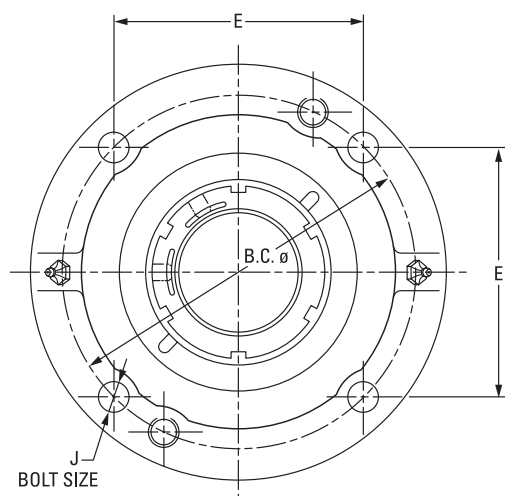

QV Single-Nut Unit⁽¹⁾

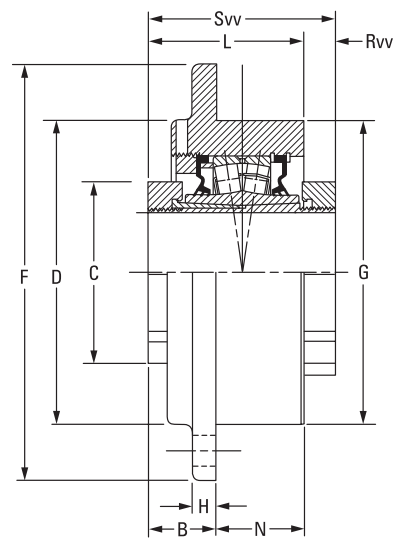

QVV Double-Nut Unit⁽¹⁾

Bearing Part No. ⁽¹⁾⁽²⁾	Shaft Dia.	Bearing No.	B _{FIX}	B _{EXP}	C	D	B.C.	E	F	G ⁽³⁾	H	J	L	N	Rv ⁽¹⁾	Rvv	Sv ⁽¹⁾	Svv	Wt.	
	mm in.		mm in.	mm in.	mm in.	mm in.	mm in.	mm in.	mm in.	mm in.	mm in.	mm in.	mm in.	mm in.	mm in.	mm in.	mm in.	mm in.	mm in.	kg lbs.
QVC11V115S	1 15/16 in.	22211	53.8	55.9	75.9	113.5	136.7	96.5	162.1	114.3	16.0	10	80.8	26.9	0.8	21.6	79.8	102.1	4.5	
QVC11V200S	2 in.		53.8	55.9	75.9	113.5	136.7	96.5	162.1	114.3	16.0	10	80.8	26.9	0.8	21.6	79.8	102.1	4.5	
QVC11V050S	50 mm		53.8	55.9	75.9	113.5	136.7	96.5	162.1	114.3	16.0	10	80.8	26.9	0.8	21.6	79.8	102.1	4.5	
QVC12V203S	2 3/16 in.	22212	51.3	53.3	80.3	127.0	152.4	107.7	185.4	127.0	14.7	12	80.0	28.7	0.3	22.1	79.8	102.1	5.9	
QVC12V204S	2 1/4 in.		51.3	53.3	80.3	127.0	152.4	107.7	185.4	127.0	14.7	12	80.0	28.7	0.3	22.1	79.8	102.1	5.9	
QVC12V055S	55 mm		51.3	53.3	80.3	127.0	152.4	107.7	185.4	127.0	14.7	12	80.0	28.7	0.3	22.1	79.8	102.1	5.9	
QVC14V060S	60 mm	22214	56.1	58.2	94.0	139.7	165.1	116.8	193.8	139.7	17.5	12	84.6	28.7	3.8	16.5	81.0	101.3	7.3	
QVC14V207S	2 7/16 in.		56.1	58.2	94.0	139.7	165.1	116.8	193.8	139.7	17.5	12	84.6	28.7	3.8	16.5	81.0	101.3	7.3	
QVC14V208S	2 1/2 in.		56.1	58.2	94.0	139.7	165.1	116.8	193.8	139.7	17.5	12	84.6	28.7	3.8	16.5	81.0	101.3	7.3	
QVC14V065S	65 mm	22216	52.8	54.9	106.4	162.1	190.5	134.6	222.3	161.9	20.6	16	84.6	31.8	1.0	19.3	83.6	103.6	10.0	
QVC16V211S	2 11/16 in.		52.8	54.9	106.4	162.1	190.5	134.6	222.3	161.9	20.6	16	84.6	31.8	1.0	19.3	83.6	103.6	10.0	
QVC16V212S	2 3/4 in.		52.8	54.9	106.4	162.1	190.5	134.6	222.3	161.9	20.6	16	84.6	31.8	1.0	19.3	83.6	103.6	10.0	
QVC16V070S	70 mm	22219	62.5	64.5	124.5	185.2	219.2	154.9	262.6	187.3	25.4	20	95.8	33.3	2.0	18.5	93.7	114.0	14.5	
QVC16V215S	2 15/16 in.		62.5	64.5	124.5	185.2	219.2	154.9	262.6	187.3	25.4	20	95.8	33.3	2.0	18.5	93.7	114.0	14.5	
QVC16V300S	3 in.		62.5	64.5	124.5	185.2	219.2	154.9	262.6	187.3	25.4	20	95.8	33.3	2.0	18.5	93.7	114.0	14.5	
QVC16V075S	75 mm	22222	60.2	62.2	139.7	222.5	238.3	168.4	276.4	206.4	25.4	20	115.3	54.1	10.4	11.7	104.9	126.7	19.5	
QVC19V303S	3 3/16 in.		60.2	62.2	139.7	222.5	238.3	168.4	276.4	206.4	25.4	20	115.3	54.1	10.4	11.7	104.9	126.7	19.5	
QVC19V304S	3 1/4 in.		60.2	62.2	139.7	222.5	238.3	168.4	276.4	206.4	25.4	20	115.3	54.1	10.4	11.7	104.9	126.7	19.5	
QVC19V080S	80 mm	22226	86.4	88.4	174.8	260.4	298.5	149.4	342.9	260.4	25.4	20	134.6	48.3	13.2	43.7	147.8	178.3	32.7	
QVC19V085S	85 mm		86.4	88.4	174.8	260.4	298.5	149.4	342.9	260.4	25.4	20	134.6	48.3	13.2	43.7	147.8	178.3	32.7	
QVC19V307S	3 7/16 in.		86.4	88.4	174.8	260.4	298.5	149.4	342.9	260.4	25.4	20	134.6	48.3	13.2	43.7	147.8	178.3	32.7	
QVC19V308S	3 1/2 in.	22226	86.4	88.4	174.8	260.4	298.5	149.4	342.9	260.4	25.4	20	134.6	48.3	13.2	43.7	147.8	178.3	32.7	
QVC19V090S	90 mm		86.4	88.4	174.8	260.4	298.5	149.4	342.9	260.4	25.4	20	134.6	48.3	13.2	43.7	147.8	178.3	32.7	
QVC22V311S	3 11/16 in.		86.4	88.4	174.8	260.4	298.5	149.4	342.9	260.4	25.4	20	134.6	48.3	13.2	43.7	147.8	178.3	32.7	
QVC22V312S	3 3/4 in.	22226	86.4	88.4	174.8	260.4	298.5	149.4	342.9	260.4	25.4	20	134.6	48.3	13.2	43.7	147.8	178.3	32.7	
QVC22V100S	100 mm		86.4	88.4	174.8	260.4	298.5	149.4	342.9	260.4	25.4	20	134.6	48.3	13.2	43.7	147.8	178.3	32.7	
QVC22V315S	3 15/16 in.		86.4	88.4	174.8	260.4	298.5	149.4	342.9	260.4	25.4	20	134.6	48.3	13.2	43.7	147.8	178.3	32.7	
QVC22V400S	4 in.	22226	86.4	88.4	174.8	260.4	298.5	149.4	342.9	260.4	25.4	20	134.6	48.3	13.2	43.7	147.8	178.3	32.7	
QVC26V110S ⁽⁴⁾	110 mm		86.4	88.4	174.8	260.4	298.5	149.4	342.9	260.4	25.4	20	134.6	48.3	13.2	43.7	147.8	178.3	32.7	
QVC26V407S ⁽⁴⁾	4 7/16 in.		86.4	88.4	174.8	260.4	298.5	149.4	342.9	260.4	25.4	20	134.6	48.3	13.2	43.7	147.8	178.3	32.7	
QVC26V408S ⁽⁴⁾	4 1/2 in.	22226	86.4	88.4	174.8	260.4	298.5	149.4	342.9	260.4	25.4	20	134.6	48.3	13.2	43.7	147.8	178.3	32.7	
QVC26V115S ⁽⁴⁾	115 mm		86.4	88.4	174.8	260.4	298.5	149.4	342.9	260.4	25.4	20	134.6	48.3	13.2	43.7	147.8	178.3	32.7	

⁽¹⁾ Bearing part numbers use QV to designate single-nut units (uses Rv and Sv dimensions) and QVV to designate double-nut units (uses Rvv and Svv dimensions).

⁽²⁾ Single-nut (QV) part number shown. Double-nut (QVV) version available upon request.

⁽³⁾ Pilot tolerance: +0/-0.05 mm (+0/-0.002 in.).

⁽⁴⁾ Six-bolt round housing.

SPHERICAL ROLLER BEARING SOLID-BLOCK HOUSED UNITS

V-LOCK SERIES • QVCW AND QVVCW PILOTED FLANGE CARTRIDGES – STRAIGHT BORE EQUIVALENT

QVCW AND QVVCW PILOTED FLANGE CARTRIDGES – STRAIGHT BORE EQUIVALENT

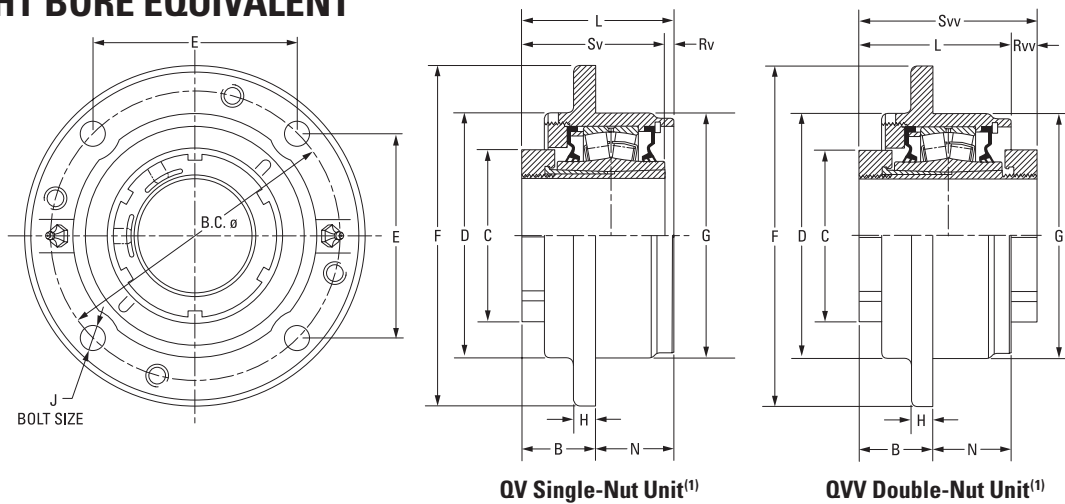

QV Single-Nut Unit⁽¹⁾

QVV Double-Nut Unit⁽¹⁾

Bearing Part No. ⁽¹⁾⁽²⁾	Shaft Dia.	Bearing No.	B _{FIX}	B _{EXP}	C	D	B.C.	E	F	G ⁽³⁾	H	J	L	N	Rv ⁽¹⁾	Rvv	Sv ⁽¹⁾	Svv	Wt.	
	mm in.		mm in.	mm in.	mm in.	mm in.	mm in.	mm in.	mm in.	mm in.	mm in.	mm in.	mm in.	mm in.	mm in.	mm in.	mm in.	mm in.	mm in.	kg lbs.
QVCW11V115S	1 15/16 in.	22211	42.2	44.2	75.9	113.5	136.7	96.5	162.1	114.3	9.7	10	80.3	38.1	0.8	21.8	79.8	102.1	4.5	
QVCW11V200S	2 in.		1.66	1.74	2.99	4.47	5.38	3.80	6.38	4.500	0.38	7/16	3.16	1.50	0.03	0.86	3.14	4.02	10	
QVCW11V050S	50 mm																			
QVCW12V203S	2 3/16 in.	22212	43.2	45.5	80.3	127.0	152.4	107.7	181.1	127.0	14.2	12	84.6	41.4	4.8	17.5	79.8	102.1	5.9	
QVCW12V204S	2 1/4 in.		1.70	1.79	3.16	5.00	6.00	4.24	7.13	5.000	0.56	1/2	3.33	1.63	0.19	0.69	3.14	4.02	13	
QVCW12V055S	55 mm																			
QVCW14V060S	60 mm	22214	41.9	43.9	94.0	139.7	165.1	116.8	193.8	139.7	12.7	12	86.4	42.9	5.3	15.0	81.0	101.3	7.3	
QVCW14V207S	2 7/16 in.		1.65	1.73	3.70	5.50	6.50	4.60	7.63	5.500	0.50	1/2	3.40	1.69	0.21	0.59	3.19	3.99	16	
QVCW14V208S	2 1/2 in.																			
QVCW14V065S	65 mm	22216	37.6	39.6	106.4	162.1	190.5	134.6	222.3	161.9	12.7	16	85.1	47.8	1.8	18.5	83.6	103.6	10.0	
QVCW16V211S	2 11/16 in.		1.48	1.56	4.19	6.38	7.50	5.30	8.75	6.375	0.50	5/8	3.35	1.88	0.07	0.73	3.29	4.08	22	
QVCW16V212S	2 3/4 in.																			
QVCW16V070S	70 mm	22219	49.8	51.8	124.5	187.5	219.2	154.9	260.4	187.3	22.4	20	97.5	47.8	3.8	16.8	93.7	114.0	14.5	
QVCW16V215S	2 15/16 in.		1.96	2.04	4.90	7.38	8.63	6.10	10.25	7.375	0.88	3/4	3.84	1.88	0.15	0.66	3.69	4.49	32	
QVCW16V300S	3 in.																			
QVCW16V075S	75 mm	22222	51.6	53.6	139.7	222.5	238.3	168.4	276.4	206.4	25.4	20	109.7	57.2	4.8	17.3	104.9	126.7	19.5	
QVCW19V303S	3 3/16 in.		2.03	2.11	5.50	8.76	9.38	6.63	10.88	8.125	1.00	3/4	4.32	2.25	0.19	0.68	4.13	4.99	43	
QVCW19V304S	3 1/4 in.																			
QVCW19V080S	80 mm	22226	72.4	74.4	174.8	260.4	298.5	149.4	342.9	260.4	25.4	20	140.5	68.3	7.4	37.8	147.8	178.3	32.7	
QVCW19V085S	85 mm		1.96	2.04	4.90	7.38	8.63	6.10	10.25	7.375	0.88	3/4	3.84	1.88	0.15	0.66	3.69	4.49	32	
QVCW19V307S	3 7/16 in.																			
QVCW19V308S	3 1/2 in.	22228	66.5	68.6	190.0	266.7	323.9	162.1	374.7	279.4	26.2	24	144.5	78.0	3.3	33.8	147.8	178.3	46.3	
QVCW19V090S	90 mm		2.62	2.70	7.48	10.50	12.75 ⁽⁴⁾	6.38 ⁽⁴⁾	14.75	11.000	1.03 ⁽⁴⁾	7/8	5.69	3.07	0.13	1.33	5.82	7.02	102	
QVCW22V311S	3 11/16 in.																			
QVCW22V312S	3 3/4 in.	22226	72.4	74.4	174.8	260.4	298.5	149.4	342.9	260.4	25.4	20	140.5	68.3	7.4	37.8	147.8	178.3	32.7	
QVCW22V100S	100 mm		2.85	2.93	6.88	10.25	11.75 ⁽⁴⁾	5.88 ⁽⁴⁾	13.50	10.250	1.00 ⁽⁴⁾	3/4	5.53	2.69	0.29	1.49	5.82	7.02	72	
QVCW22V315S	3 15/16 in.																			
QVCW22V400S	4 in.	22228	66.5	68.6	190.0	266.7	323.9	162.1	374.7	279.4	26.2	24	144.5	78.0	3.3	33.8	147.8	178.3	46.3	
QVCW26V110S ⁽⁴⁾	110 mm		2.62	2.70	7.48	10.50	12.75 ⁽⁴⁾	6.38 ⁽⁴⁾	14.75	11.000	1.03 ⁽⁴⁾	7/8	5.69	3.07	0.13	1.33	5.82	7.02	102	
QVCW26V407S ⁽⁴⁾	4 7/16 in.																			
QVCW26V408S ⁽⁴⁾	4 1/2 in.																			
QVCW26V115S ⁽⁴⁾	115 mm	22228	66.5	68.6	190.0	266.7	323.9	162.1	374.7	279.4	26.2	24	144.5	78.0	3.3	33.8	147.8	178.3	46.3	
QVCW28V125S ⁽⁴⁾	125 mm		2.62	2.70	7.48	10.50	12.75 ⁽⁴⁾	6.38 ⁽⁴⁾	14.75	11.000	1.03 ⁽⁴⁾	7/8	5.69	3.07	0.13	1.33	5.82	7.02	102	
QVCW28V415S ⁽⁴⁾	4 15/16 in.																			
QVCW28V500S ⁽⁴⁾	5 in.																			
QVCW28V130S ⁽⁴⁾	130 mm																			

⁽¹⁾Bearing part numbers use QV to designate single-nut units (uses Rv and Sv dimensions) and QVV to designate double-nut units (uses Rvv and Sv dimensions).

⁽²⁾Single-nut (QV) part number shown. Double-nut (QVV) version available upon request.

⁽³⁾Pilot tolerance: +0/-0.05 mm (+0/-0.002 in.).

⁽⁴⁾Six-bolt round housing.

SPHERICAL ROLLER BEARING SOLID-BLOCK HOUSED UNITS

V-LOCK SERIES • QVMC AND QVVMC CARTRIDGE BLOCKS – TAPERED BORE EQUIVALENT

QVMC AND QVVMC CARTRIDGE BLOCKS – TAPERED BORE EQUIVALENT

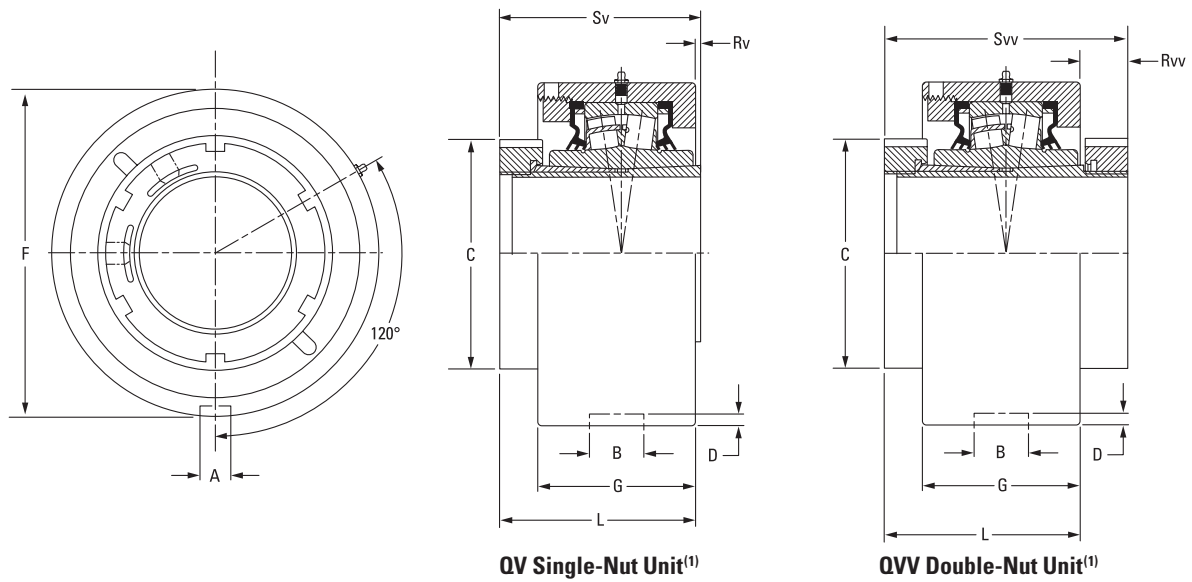

Bearing Part No. ⁽¹⁾⁽²⁾	Shaft Dia.	Bearing No.	A	B	C	D	F	G	L FIX	L EXP	Rv ⁽¹⁾	Rvv	Sv ⁽¹⁾	Svv	Wt.
	mm in.		mm in.	mm in.	mm in.	mm in.	mm in.	mm in.	mm in.	mm in.	mm in.	mm in.	mm in.	mm in.	kg lbs.
QVMC11V115S	1 15/16 in.	22211	13.5 0.530	23.0 0.906	75.9 2.99	4.8 0.188	115.09	55.4 2.180	79.0 3.11	81.0 3.19	0.8 0.03	23.1 0.91	79.8 3.14	102.1 4.02	4.5 10
QVMC11V200S	2 in.						(+0/-0.05) 4.531								
QVMC11V050S	50 mm						(+0/-0.002)								
QVMC13V203S	2 3/16 in.	22213	13.5 0.530	23.0 0.906	80.3 3.16	4.8 0.188	127.00	67.1 2.640	85.9 3.38	87.9 3.46	0.5 0.02	21.8 0.86	85.3 3.36	107.7 4.24	5.4 12
QVMC13V204S	2 1/4 in.						(+0/-0.05) 5.000								
QVMC13V055S	55 mm						(+0/-0.002)								
QVMC15V060S	60 mm	22215	15.1 0.594	26.2 1.032	94.0 3.70	6.4 0.250	149.23	70.6 2.780	87.4 3.44	89.4 3.52	5.1 0.20	16.5 0.65	82.6 3.25	103.9 4.09	8.2 18
QVMC15V207S	2 7/16 in.						(+0/-0.05) 5.875								
QVMC15V208S	2 1/2 in.						(+0/-0.002)								
QVMC15V065S	65 mm	22217	15.1 0.594	27.5 1.083	106.4 4.19	7.1 0.281	171.45	74.9 2.950	91.2 3.59	93.2 3.67	6.4 0.25	15.0 0.59	84.6 3.33	106.2 4.18	11.8 26
QVMC17V211S	2 11/16 in.						(+0/-0.05) 6.75								
QVMC17V212S	2 3/4 in.						(+0/-0.002)								
QVMC17V070S	70 mm	22220	19.8 0.781	32.5 1.281	124.5 4.90	8.0 0.313	206.38	85.6 3.370	102.1 4.02	104.1 4.10	6.9 0.27	15.2 0.60	95.3 3.75	117.3 4.62	14.5 32
QVMC20V303S	3 3/16 in.						(+0/-0.05) 8.125								
QVMC20V304S	3 1/4 in.						(+0/-0.002)								
QVMC20V080S	80 mm	22222	19.8 0.781	32.5 1.281	139.7 5.50	8.0 0.313	222.25	97.8 3.850	113.0 4.45	115.1 4.53	8.1 0.32	14.0 0.55	104.9 4.13	126.7 4.99	18.1 40
QVMC20V085S	85 mm						(+0/-0.08) 8.75								
QVMC20V307S	3 7/16 in.						(+0/-0.003)								
QVMC20V308S	3 1/2 in.	22226	19.8 0.780	38.1 1.500	174.8 6.88	8.0 0.313	265.10	104.4 4.110	141.5 5.57	143.5 5.65	6.4 0.25	36.8 1.45	147.8 5.82	178.3 7.02	23.6 52
QVMC20V090S	90 mm						(+0/-0.08) 10.437								
QVMC22V311S	3 11/16 in.						(+0/-0.003)								
QVMC22V312S	3 3/4 in.	22226	19.8 0.780	38.1 1.500	174.8 6.88	8.0 0.313	265.10	104.4 4.110	141.5 5.57	143.5 5.65	6.4 0.25	36.8 1.45	147.8 5.82	178.3 7.02	23.6 52
QVMC22V100S	100 mm						(+0/-0.08) 10.437								
QVMC22V315S	3 15/16 in.						(+0/-0.003)								
QVMC22V400S	4 in.	22226	19.8 0.780	38.1 1.500	174.8 6.88	8.0 0.313	265.10	104.4 4.110	141.5 5.57	143.5 5.65	6.4 0.25	36.8 1.45	147.8 5.82	178.3 7.02	23.6 52
QVMC26V110S	110 mm						(+0/-0.08) 10.437								
QVMC26V407S	4 7/16 in.						(+0/-0.003)								
QVMC26V408S	4 1/2 in.	22226	19.8 0.780	38.1 1.500	174.8 6.88	8.0 0.313	265.10	104.4 4.110	141.5 5.57	143.5 5.65	6.4 0.25	36.8 1.45	147.8 5.82	178.3 7.02	23.6 52
QVMC26V115S	115 mm						(+0/-0.003)								

⁽¹⁾Bearing part numbers use QV to designate single-nut units (uses Rv and Sv dimensions) and QVV to designate double-nut units (uses Rvv and Sv dimensions).

⁽²⁾Single-nut (QV) part number shown. Double-nut (QVV) version available upon request.

SPHERICAL ROLLER BEARING SOLID-BLOCK HOUSED UNITS

V-LOCK SERIES • QVVTU TAKE-UP BLOCKS – STRAIGHT BORE EQUIVALENT

QVVTU TAKE-UP BLOCKS – STRAIGHT BORE EQUIVALENT

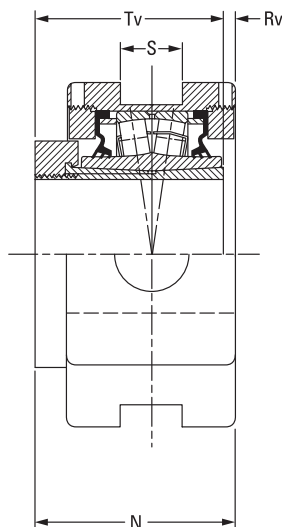
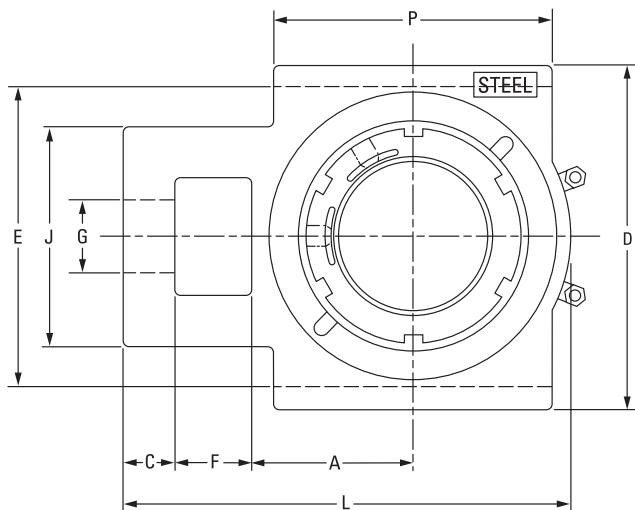

QV Single-Nut Unit

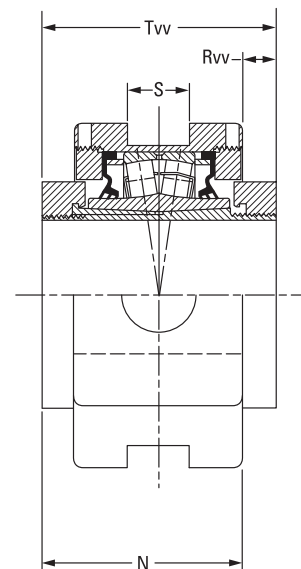

QVV Double-Nut Unit

Bearing Part No. ⁽¹⁾	Shaft Dia.	Bearing No.	A	C	D	E	F	G	J	L	N	P	S	Rv ⁽¹⁾	Rvv	Tv ⁽¹⁾	Tvv	Wt.	
	mm in.		mm in.	mm in.	mm in.	mm in.	mm in.	mm in.	mm in.	mm in.	mm in.	mm in.	mm in.	mm in.	mm in.	mm in.	mm in.	kg in.	
QVVTU14V060S	60 mm	22214	69.9	22.4	149.4	130.3	33.3	33.3	95.3	193.8	88.4	120.7	26.9	3.3	15.5	85.1	103.9	7.7	
QVVTU14V207S	2 7/16 in.		2.75	0.88	5.88	5.13	1.31	1.31	3.75	7.63	3.48	4.75	1.06	0.13	0.61	3.35	4.09	17	
QVVTU14V208S	2 1/2 in.																		
QVVTU14V065S	65 mm																		
QVVTU16V211S	2 11/16 in.	22216	76.2	25.4	171.5	150.9	39.6	39.6	108.0	219.7	90.2	120.7	46.0	2.3	16.3	87.6	106.2	15.9	
QVVTU16V212S	2 3/4 in.		3.00	1.00	6.75	5.94	1.56	1.56	4.25	8.65	3.55	4.75	1.81	0.09	0.64	3.45	4.18	35	
QVVTU16V070S	70 mm																		
QVVTU16V215S	2 15/16 in.																		
QVVTU16V300S	3 in.																		
QVVTU16V075S	75 mm																		
QVVTU19V303S	3 3/16 in.	22219	92.2	25.4	193.8	173.0	46.0	47.8	124.0	257.0	99.6	158.8	46.0	0.5	18.0	99.1	117.6	20.0	
QVVTU19V304S	3 1/4 in.		3.63	1.00	7.63	6.81	1.81	1.88	4.88	10.12	3.92	6.25	1.81	0.02	0.71	3.90	4.63	44	
QVVTU19V080S	80 mm																		
QVVTU19V085S	85 mm																		
QVVTU19V307S	3 7/16 in.																		
QVVTU19V308S	3 1/2 in.																		
QVVTU19V090S	90 mm																		
QVVTU22V311S	3 11/16 in.	22222	104.9	28.7	239.8	219.2	54.1	52.3	143.0	296.9	111.3	177.8	52.3	1.5	18.8	110.0	130.3	26.3	
QVVTU22V312S	3 3/4 in.		4.13	1.13	9.44	8.63	2.13	2.06	5.63	11.69	4.38	7.00	2.06	0.06	0.74	4.33	5.13	58	
QVVTU22V100S	100 mm																		
QVVTU22V315S	3 15/16 in.																		
QVVTU22V400S	4 in.																		

⁽¹⁾Double-nut (QVV) part number shown. Single-nut (QV) version available upon request.

CL SERIES

Available in both single-collar (QA) and double-collar (QAA) versions, the CL bearing series features a concentric locking collar with two set screws at 60 degrees to provide maximum positive locking power with minimal run out.



Fig. C-43. CL series single-collar (QA) insert available up to 100 mm (4 in.).

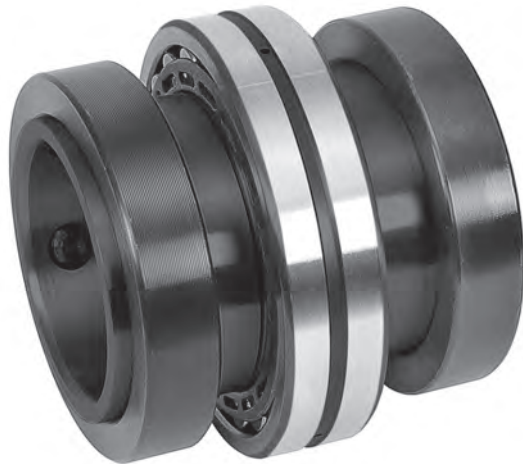

Fig. C-44. CL series double-collar (QAA) insert for size ranges 50 mm – 130 mm (1 15/16 in. – 5 in.).

YOU HAVE CHOICES

For the CL series, you can select either single-collar or double-collar versions and choose from many seal configurations and housing styles, which are shown on page C-100.

HOUSINGS

- Two-bolt pillow blocks.
- Four-bolt pillow blocks.
- Flange blocks.
- Piloted flange cartridges.
- Take-up blocks.
- Cartridge blocks.
- Hanger blocks.

SEALS

- Labyrinth: DuPont Teflon (T).
- Triple-lip: nitrile rubber (M), urethane (O) and DuPont Viton (N).
- Double-lip: nitrile rubber (B) and DuPont Viton (C).
- Steel and urethane closed-end covers (CS).
- Steel and urethane open-end covers (CJ) with:
 - DuPont Teflon (T).
 - Triple-lip seal (DR).
 - V-ring seal (VR).
- Piloted flange cartridge backing plates (HSY) with:
 - Triple-lip seal (DR).
- Flange block backing plates (UFP).
 - V-ring (VR).

SPHERICAL ROLLER BEARING SOLID-BLOCK HOUSED UNITS

CL SERIES

CL SERIES

	Housing Type	Primary Seals						Secondary Seals and Covers						
		M	N	O	B	C	T	Open-End Cover			Closed-End Cover	HSY Flange Cartridge Backing Plate	UFP Backing Plate	
		DR	VR	T	DR									
V-Lock (Timken Exclusive Double Taper Lock)	Pillow Block	•	•	•	•	•	•	•	•	•	•	•		
	Flange Block	•	•	•	•	•	•	•	•	•	•	•		
	Piloted Flange Cartridge	•	•	•	•	•	•	•	•	•	•	•		
	Take-Up Block	•	•	•	•	•	•	•	•	•	•	•		
	Cartridge Block	•	•	•	•	•	•	•	•	•	•	•		
CL Series (Set Screw Lock)	Pillow Block	•	•	•	•	•	•	•	•	•	•	•		
	Flange Block	•	•	•	•	•	•	•	•	•	•	•		•
	Piloted Flange Cartridge	•	•	•	•	•	•	•	•	•	•	•	•	
	Take-Up Block	•	•	•	•	•	•	•	•	•	•	•		
	Cartridge Block	•	•	•	•	•	•	•	•	•	•	•		
	Hangar Block	•	•	•	•	•	•	•	•	•	•	•		
EC Series (Eccentric Lock)	Pillow Block	•	•	•	•	•	•	•	•	•	•	•		
	Flange Block	•	•	•	•	•	•	•	•	•	•	•		•
	Piloted Flange Cartridge	•	•	•	•	•	•	•	•	•	•	•	•	
	Take-Up Block	•	•	•	•	•	•	•	•	•	•	•		
	Cartridge Block	•	•	•	•	•	•	•	•	•	•	•		
	Hangar Block	•	•	•	•	•	•	•	•	•	•	•		
TA Series (Tapered Adapter Lock)	Pillow Block	•	•	•	•	•	•	•	•	•	•	•		
	Flange Block	•	•	•	•	•	•	•	•	•	•	•		
	Piloted Flange Cartridge	•	•	•	•	•	•	•	•	•	•	•		
	Cartridge Block	•	•	•	•	•	•	•	•	•	•	•		
DV Series (Tapered Adapter Lock)	Pillow Block	•	•	•	•	•	•	•	•	•	•	•		
	Flange Block	•	•	•	•	•	•	•	•	•	•	•		
	Piloted Flange Cartridge	•	•	•	•	•	•	•	•	•	•	•		

QAP AND QAAP TWO-BOLT PILLOW BLOCKS

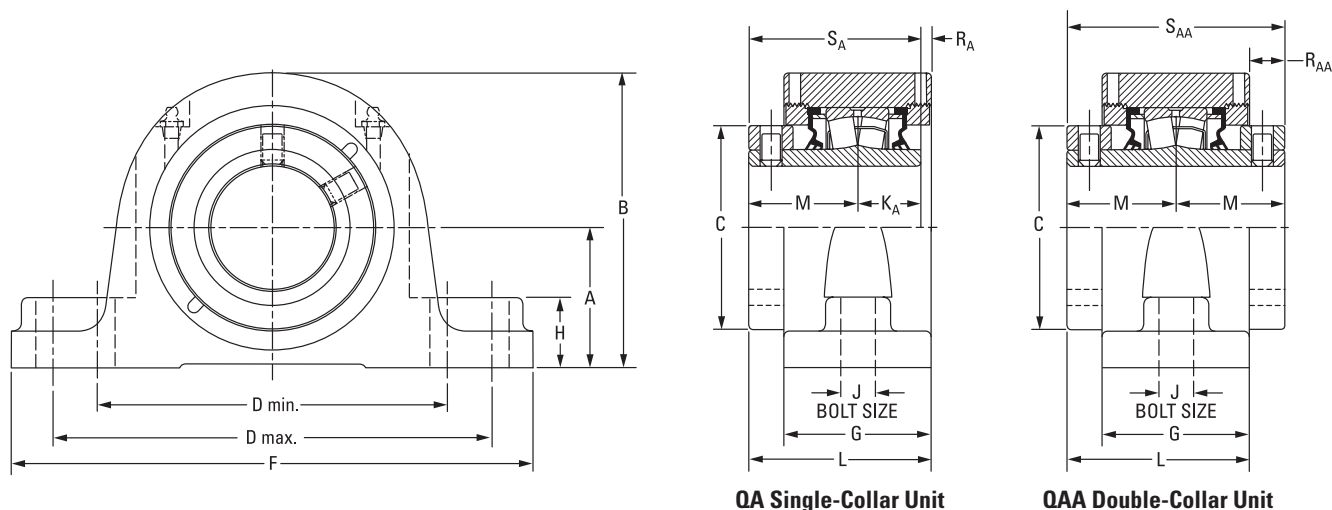

Bearing Part No. ⁽¹⁾	Shaft Dia.	Bearing No.	A	B	C	D min.	D max.	F	G	H	J	K _A	L	M	R _A	R _{AA}	S _A	S _{AA}	Wt.	
	mm in.		mm in.	mm in.	mm in.	mm in.	mm in.	mm in.	mm in.	mm in.	mm in.	mm in.	mm in.	mm in.	mm in.	mm in.	mm in.	mm in.	mm in.	kg lbs.
QAP08A035S	35 mm	22208	47.8	94.7	60.5	119.1	152.4	174.8	57.2	25.4	12	25.4	73.2	44.5	3.3	-	69.9	-	4.1	
QAP08A107S	1 7/16 in.		1.88	3.73	2.38	4.69	6.00	6.88	2.25	1.00	1/2	1.00	2.88	1.75	0.13	-	2.75	-	9	
QAP08A108S	1 1/2 in.	22208	54.1	101.1	60.5	119.1	165.1	200.2	57.2	25.4	12	25.4	73.2	44.5	3.3	-	69.9	-	4.1	
			2.13	3.98	2.38	4.69	6.50	7.88	2.25	1.00	1/2	1.00	2.88	1.75	0.13	-	2.75	-	9	
QAP09A111S	1 11/16 in.	22209	54.1	104.9	66.8	144.8	165.1	200.2	60.2	31.8	12	25.4	78.0	47.8	4.8	-	73.2	-	4.5	
			2.13	4.13	2.63	5.70	6.50	7.88	2.37	1.25	1/2	1.00	3.07	1.88	0.19	-	2.88	-	10	
QAP09A040S	40 mm	22209	57.2	108.0	66.8	158.8	180.8	225.6	62.0	31.8	16	25.4	78.7	47.8	5.6	-	73.2	-	4.5	
QAP09A112S	1 3/4 in.		2.25	4.25	2.63	6.25	7.12	8.88	2.44	1.25	5/8	1.00	3.10	1.88	0.22	-	2.88	-	10	
QAP09A045S	45mm																			
QAP10A115S	1 15/16 in.	22210	57.2	122.2	73.2	152.4	181.1	225.6	62.0	31.8	16	25.4	79.0	47.5	6.1	17.0	72.9	95.3	5.9	
QAAP10A115S			2.25	4.81	2.88	6.00	7.13	8.88	2.44	1.25	5/8	1.00	3.11	1.87	0.24	0.67	2.87	3.75	13	
QAP10A200S	2 in.																			
QAAP10A200S																				
QAP10A050S	50 mm																			
QAAP10A050S																				
QAP11A203S	2 3/16 in.	22211	63.5	133.4	82.6	165.1	200.2	244.6	66.8	31.8	16	28.7	84.3	50.8	4.8	17.5	79.5	101.6	7.7	
QAAP11A203S			2.50	5.25	3.25	6.50	7.88	9.63	2.63	1.25	5/8	1.13	3.32	2.00	0.19	0.69	3.13	4.00	17	
QAP11A204S	2 1/4 in.																			
QAAP11A204S																				
QAP11A055S	55 mm																			
QAAP11A055S																				
QAP13A060S	60 mm	22213	69.9	147.3	96.8	174.8	219.2	260.4	73.7	35.1	16	31.5	91.4	54.6	5.3	17.8	86.1	109.2	10.0	
QAAP13A060S			2.75	5.80	3.81	6.88	8.63	10.25	2.90	1.38	5/8	1.24	3.60	2.15	0.21	0.70	3.39	4.30	22	
QAP13A207S	2 7/16 in.																			
QAAP13A207S																				
QAP13A208S	2 1/2 in.																			
QAAP13A208S																				
QAP13A065S	65 mm																			
QAAP13A065S																				

⁽¹⁾Bearing part numbers use QA to designate single-collar units (use S_A and R_A dimensions) and QAA to designate double-collar units (use S_{AA} and R_{AA} dimensions).

Continued on next page.

SPHERICAL ROLLER BEARING SOLID-BLOCK HOUSED UNITS

CL SERIES • QAP AND QAAP TWO-BOLT PILLOW BLOCKS

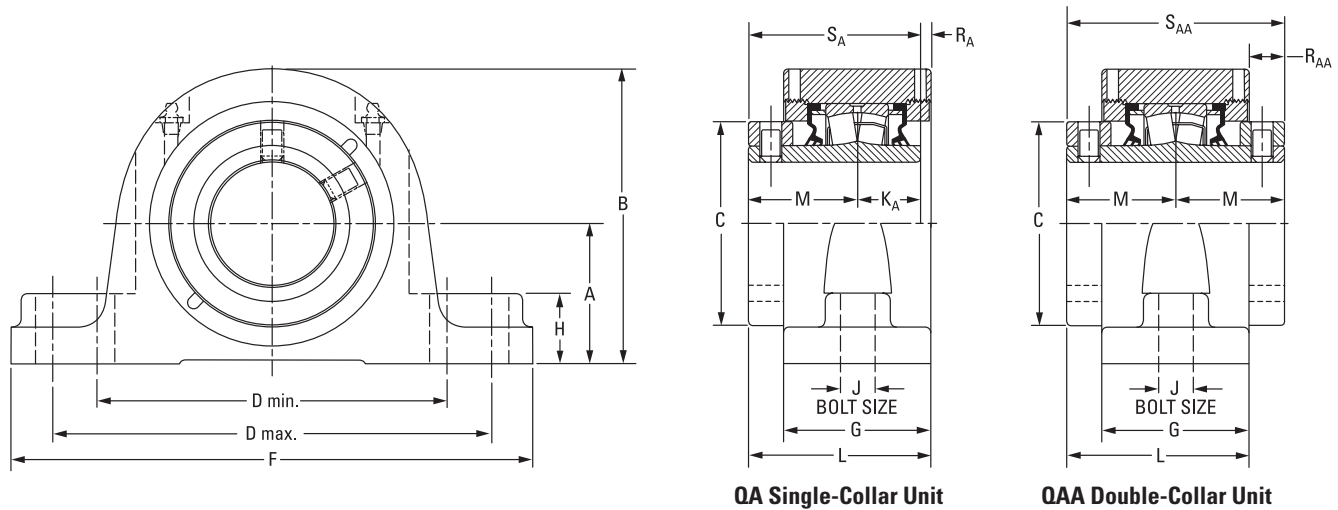

Continued from previous page.

Bearing Part No. ⁽¹⁾	Shaft Dia.	Bearing No.	A	B	C	D min.	D max.	F	G	H	J	K _A	L	M	R _A	R _{AA}	S _A	S _{AA}	Wt.	
	mm in.		mm in.	mm in.	mm in.	mm in.	mm in.	mm in.	mm in.	mm in.	mm in.	mm in.	mm in.	mm in.	mm in.	mm in.	mm in.	mm in.	mm in.	kg lbs.
QAP15A211S QAAP15A211S	2 1/16 in.	22215	79.5 3.13	164.3 6.47	109.0 4.29	200.2 7.88	244.6 9.63	295.4 11.63	76.2 3.00	35.1 1.38	20 3/4	31.8 1.25	98.3 3.87	60.2 2.37	6.4 0.25	22.1 0.87	91.9 3.62	120.4 4.74	12.7 28	
QAP15A212S QAAP15A212S	2 3/4 in.																			
QAP15A070S QAAP15A070S	70 mm																			
QAP15A215S QAAP15A215S	2 15/16 in.																			
QAP15A300S QAAP15A300S	3 in.																			
QAP15A075S QAAP15A075S	75 mm																			
QAP18A303S QAAP18A303S	3 3/16 in.	22218	95.3 3.75	195.3 7.69	130.3 5.13	238.3 9.38	285.8 11.25	342.9 13.50	86.6 3.41	47.8 1.88	24 7/8	36.6 1.44	109.2 4.30	65.8 2.59	6.9 0.27	22.6 0.89	102.4 4.03	131.6 5.18	20.4 45	
QAP18A304S QAAP18A304S	3 1/4 in.																			
QAP18A080S QAAP18A080S	80 mm																			
QAP18A085S QAAP18 A085S	85 mm																			
QAP18A307S QAAP18A307S	3 7/16 in.																			
QAP18A308S QAAP18A308S	3 1/2 in.																			
QAP18A090S QAAP18A090S	90 mm	22220	104.9 4.13	209.8 8.26	152.4 6.00	255.0 10.04	320.0 12.60	362.0 14.25	94.7 3.73	50.8 2.00	24 1	41.4 1.63	122.9 4.84	75.4 2.97	6.1 0.24	28.2 1.11	116.8 4.60	150.9 5.94	26.8 59	
QAP20A315S QAAP20A315S	3 15/16 in.																			
QAP20A400S QAAP20A400S	4 in.																			
QAP20A100S QAAP20A100S	100 mm																			

⁽¹⁾Bearing part numbers use QA to designate single-collar units (use S_A and R_A dimensions) and QAA to designate double-collar units (use S_{AA} and R_{AA} dimensions).

QAPL AND QAAPL TWO-BOLT PILLOW BLOCKS

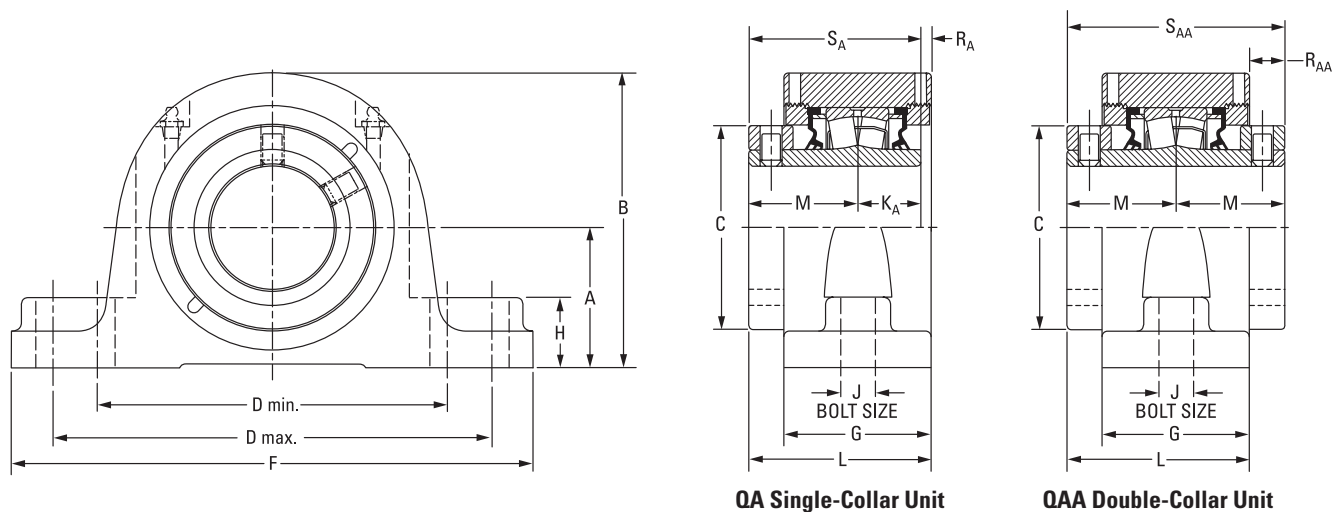

Bearing Part No. ⁽¹⁾	Shaft Dia.	Bearing No.	A	B	C	D min.	D max.	F	G	H	J	K _A	L	M	R _A	R _{AA}	S _A	S _{AA}	Wt.	
	mm in.		mm in.	mm in.	mm in.	mm in.	mm in.	mm in.	mm in.	mm in.	mm in.	mm in.	mm in.	mm in.	mm in.	mm in.	mm in.	mm in.	mm in.	kg lbs.
QAPL08A035S	35 mm	22208	47.8	94.7	60.5	119.1	152.4	174.8	57.2	25.4	12	25.4	73.2	44.5	3.3	-	69.9	-	4.1	
QAPL08A107S	1 7/16 in.		1.88	3.73	2.38	4.69	6.00	6.88	2.25	1.00	1/2	1.00	2.88	1.75	0.13	-	2.75	-	9	
QAPL08A108S	1 1/2 in.																			
QAPL09A040S	40 mm	22209	54.1	104.9	66.8	133.4	146.1	181.1	60.2	31.8	12	25.4	78.0	47.8	4.8	-	73.2	-	4.5	
QAPL09A111S	1 11/16 in.		2.13	4.13	2.63	5.25	5.75	7.13	2.37	1.25	1/2	1.00	3.07	1.88	0.19	-	2.88	-	10	
QAPL09A112S	1 3/4 in.																			
QAPL09A045S	45 mm	22210	57.2	122.2	73.2	150.6	161.5	212.9	62.0	31.8	16	25.4	79.0	47.5	6.1	17.0	72.9	95.3	5.9	
QAPL10A115S QAAPL10A115S	1 15/16 in.		2.25	4.81	2.88	5.93	6.36	8.38	2.44	1.25	5/8	1.00	3.11	1.87	0.24	0.67	2.87	3.75	13	
QAPL10A200S QAAPL10A200S	2 in.																			
QAPL10A050S QAAPL10A050S	50 mm	22211	63.5	133.4	82.6	165.1	179.3	225.6	65.5	31.8	16	28.7	83.6	50.8	4.1	18.0	79.5	101.6	7.7	
QAPL11A203S QAAPL11A203S	2 3/16 in.		2.50	5.25	3.25	6.50	7.06	8.88	2.58	1.25	5/8	1.13	3.29	2.00	0.16	0.71	3.13	4.00	17	
QAPL11A204S QAAPL11A204S	2 1/4 in.																			
QAPL11A055S QAAPL11A055S	55 mm	22213	69.9	147.3	96.8	173.0	189.0	235.0	73.7	35.1	16	31.5	91.4	54.6	5.3	17.8	86.1	109.2	10.0	
QAPL13A060S QAAPL13A060S	60 mm		2.75	5.80	3.81	6.81	7.44	9.25	2.90	1.38	5/8	1.24	3.60	2.15	0.21	0.70	3.39	4.30	22	
QAPL13A207S QAAPL13A207S	2 7/16 in.																			
QAPL13A208S QAAPL13A208S	2 1/2 in.																			
QAPL13A065S QAAPL13A065S	65 mm																			

⁽¹⁾Bearing part numbers use QA to designate single-collar units (use S_A and R_A dimensions) and QAA to designate double-collar units (use S_{AA} and R_{AA} dimensions).

Continued on next page.

SPHERICAL ROLLER BEARING SOLID-BLOCK HOUSED UNITS

CL SERIES • QAPL AND QAAPL TWO-BOLT PILLOW BLOCKS

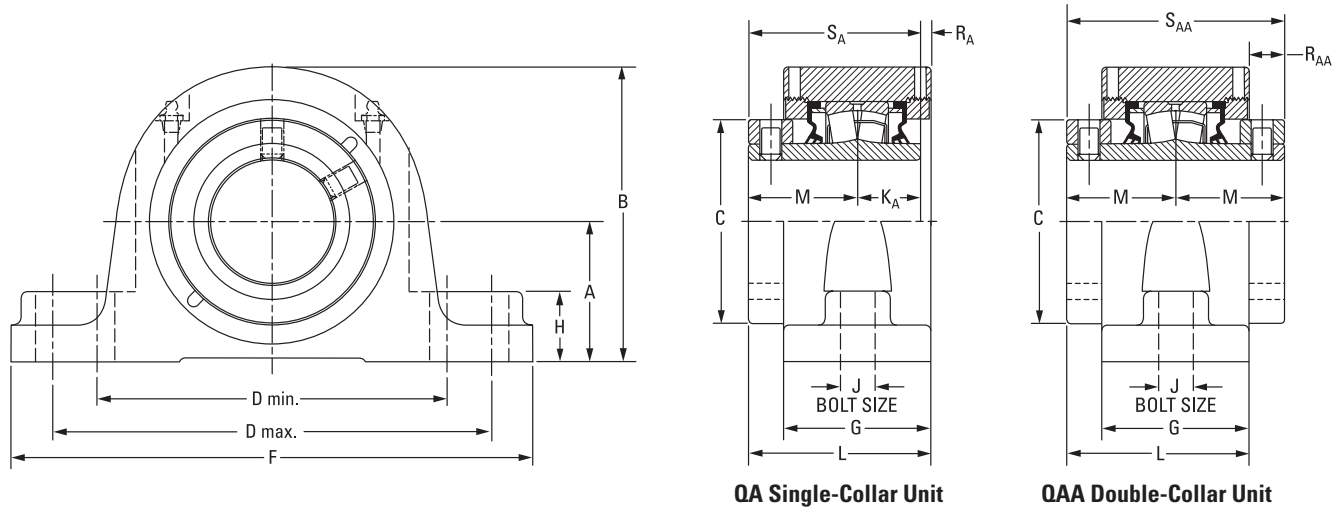

Continued from previous page.

Bearing Part No. ⁽¹⁾	Shaft Dia.	Bearing No.	A	B	C	D min.	D max.	F	G	H	J	K _A	L	M	R _A	R _{AA}	S _A	S _{AA}	Wt.	
	mm in.		mm in.	mm in.	mm in.	mm in.	mm in.	mm in.	mm in.	mm in.	mm in.	mm in.	mm in.	mm in.	mm in.	mm in.	mm in.	mm in.	mm in.	kg lbs.
QAPL15A211S QAAPL15A211S	2 11/16 in.	22215	82.6 3.25	167.4 6.59	109.0 4.29	195.6 7.70	213.4 8.40	265.2 10.44	76.2 3.00	35.1 1.38	20 3/4	31.8 1.25	98.3 3.87	60.2 2.37	6.4 0.25	22.1 0.87	91.9 3.62	120.4 4.74	12.7 28	
QAPL15A212S QAAPL15A212S	2 3/4 in.																			
QAPL15A070S QAAPL15A070S	70 mm																			
QAPL15A215S QAAPL15A215S	2 15/16 in.																			
QAPL15A300S QAAPL15A300S	3 in.																			
QAPL15A075S QAAPL15A075S	75 mm																			
QAPL18A303S QAAPL18A303S	3 3/16 in.	22218	95.3 3.75	195.3 7.69	130.3 5.13	235.0 9.25	273.1 10.75	330.2 13.00	86.6 3.41	47.8 1.88	24 7/8	36.6 1.44	109.2 4.30	65.8 2.59	6.9 0.27	22.6 0.89	102.4 4.03	131.6 5.18	20.4 45	
QAPL18A304S QAAPL18A304S	3 1/4 in.																			
QAPL18A080S QAAPL18A080S	80 mm																			
QAPL18A085S QAAPL18A085S	85 mm																			
QAPL18A307S QAAPL18A307S	3 7/16 in.																			
QAPL18A308S QAAPL18A308S	3 1/2 in.																			
QAPL18A090S QAAPL18A090S	90 mm	22220	108.0 4.25	212.9 8.38	152.4 6.00	255.0 10.04	320.0 12.60	362.0 14.25	94.7 3.73	54.1 2.13	24 1	41.4 1.63	122.9 4.84	75.4 2.97	6.1 0.24	28.2 1.11	116.8 4.60	150.9 5.94	26.8 59	
QAPL20A315S QAAPL20A315S	3 15/16 in.																			
QAPL20A400S QAAPL20A400S	4 in.																			
QAPL20A100S QAAPL20A100S	100 mm																			

⁽¹⁾Bearing part numbers use QA to designate single-collar units (use S_A and R_A dimensions) and QAA to designate double-collar units (use S_{AA} and R_{AA} dimensions).

QASN AND QAASN SN-STYLE TWO-BOLT PILLOW BLOCKS – PURE METRIC DESIGN

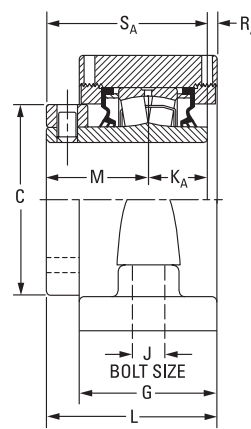
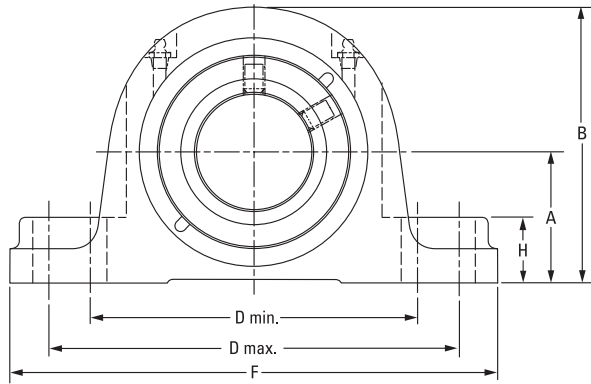

QA Single-Collar Unit

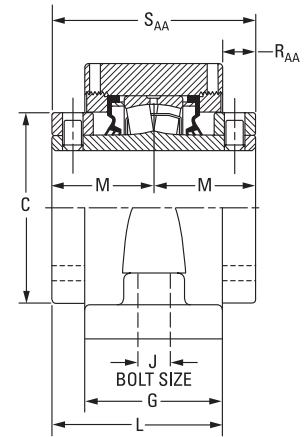

QAA Double-Collar Unit

Bearing Part No. ⁽¹⁾	Shaft Dia.	Bearing No.	A	B	C	D min.	D max.	F	G	H	J	K _A	L	M	R _A	R _{AA}	S _A	S _{AA}	Wt.	
	mm in.		mm in.	mm in.	mm in.	mm in.	mm in.	mm in.	mm in.	mm in.	mm in.	mm in.	mm in.	mm in.	mm in.	mm in.	mm in.	mm in.	mm in.	kg lbs.
QASN08A035S	35 mm																			
QASN08A107S	1 7/16 in.	22208	60	111	60.5	159	175	205	62	35	12	25	75	44	5	—	70	—	10.5	
QASN08A108S	1 1/2 in.		2.36	4.37	2.38	6.26	6.89	8.07	2.44	1.38	1/2	1.00	2.95	1.75	0.20	—	2.75	—	23	
QASN09A040S	40 mm																			
QASN09A111S	1 11/16 in.	22209	60	111	66.8	159	175	205	62	35	12	25	79	48	6	—	73	—	10.5	
QASN09A112S	1 3/4 in.		2.36	4.37	2.63	6.26	6.89	8.07	2.44	1.38	1/2	1.00	3.10	1.88	0.22	—	2.88	—	23	
QASN09A045S	45mm																			
QASN10A115S	1 15/16 in.																			
QAASN10A115S																				
QASN10A200S	2 in.	22210	70	136	73	183	216	254	68	25	16	25.4	82	48	9	14	73	95	12.7	
QAASN10A200S			2.76	5.35	2.87	7.20	8.50	10.00	2.68	0.98	5/8	1	3.23	1.87	0.35	0.55	2.87	3.75	28	
QASN10A050S	50 mm																			
QAASN10A050S																				
QASN11A203S	2 3/16 in.																			
QAASN11A203S																				
QASN11A204S	2 1/4 in.	22211	70	141	83	183	216	254	68	25	16	29	85	51	5	17	80	102	13.2	
QAASN11A204S			2.76	5.55	3.27	7.20	8.50	10.00	2.68	0.98	5/8	1.14	3.35	2.01	0.20	0.67	3.15	4.02	29	
QASN11A055S	55 mm																			
QAASN11A055S																				
QASN13A060S	60 mm																			
QAASN13A060S																				
QASN13A207S	2 7/16 in.																			
QAASN13A207S																				
QASN13A208S	2 1/2 in.	22213	80	157	96.8	196	235	275	74	35	16	31	92	55	6	18	86	110	15.9	
QAASN13A208S			3.15	6.18	3.81	7.72	9.25	10.83	2.91	1.38	5/8	1.22	3.62	2.17	0.24	0.71	3.39	4.33	35	
QASN13A065S	65 mm																			
QAASN13A065S																				
QASN15A211S	2 11/16 in.																			
QAASN15A211S																				
QASN15A212S	2 3/4 in.																			
QAASN15A212S																				
QASN15A070S	70 mm																			
QAASN15A070S																				
QASN15A215S	2 15/16 in.	22215	95	183	109.0	241	279	316	76	34	20	32	98	60	6	22	92	120	20.9	
QAASN15A215S			3.74	7.20	4.29	9.49	10.98	12.44	2.99	1.34	3/4	1.26	3.86	2.36	0.24	0.87	3.62	4.72	46	
QASN15A300S	3 in.																			
QAASN15A300S																				
QASN15A075S	75 mm																			
QAASN15A075S																				

⁽¹⁾Bearing part numbers use QA to designate single-collar units (use S_A and R_A dimensions) and QAA to designate double-collar units (use S_{AA} and R_{AA} dimensions).

Continued on next page.

SPHERICAL ROLLER BEARING SOLID-BLOCK HOUSED UNITS

CL SERIES • QASN AND QAASN SN-STYLE TWO-BOLT PILLOW BLOCKS – PURE METRIC DESIGN

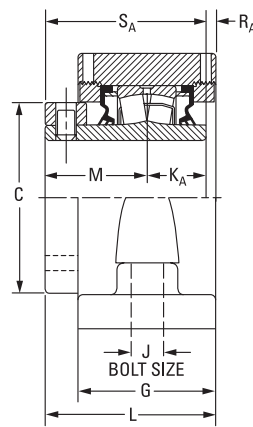
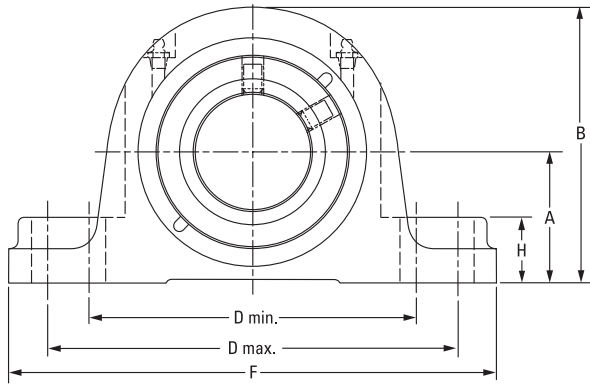

QA Single-Collar Unit

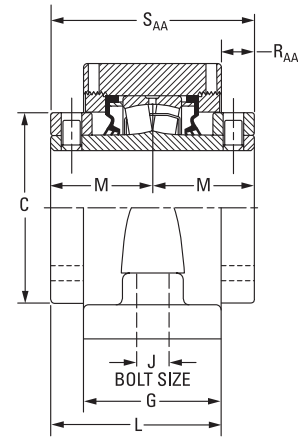

QAA Double-Collar Unit

Continued from previous page.

Bearing Part No. ⁽¹⁾	Shaft Dia.	Bearing No.	A	B	C	D min.	D max.	F	G	H	J	K _A	L	M	R _A	R _{AA}	S _A	S _{AA}	Wt.	
	mm in.		mm in.	mm in.	mm in.	mm in.	mm in.	mm in.	mm in.	mm in.	mm in.	mm in.	mm in.	mm in.	mm in.	mm in.	mm in.	mm in.	mm in.	kg lbs.
QASN18A303S QAASN18A303S	3 3/16 in.	22218	100	200	130	279	292	345	86	39	20	37	109	66	6	23	102	132	25.5	
QASN18A304S QAASN18A304S	3 1/4 in.		3.94	7.87	5.12	10.98	11.50	13.58	3.39	1.54	3/4	1.46	4.29	2.60	0.24	0.91	4.02	5.20	56	
QASN18A080S QAASN18A080S	80 mm	22218	112	212	130	279	292	345	86	39	20	37	109	66	6	23	102	132	25.5	
QASN18A085S QAASN18A085S	85 mm		4.41	8.35	5.12	10.98	11.50	13.58	3.39	1.54	3/4	1.46	4.29	2.60	0.24	0.91	4.02	5.20	56	
QASN18A307S QAASN18A307S	3 7/16 in.	22218	112	212	130	290	327	380	86	39	24	37	109	66	6	23	102	132	25.5	
QASN18A308S QAASN18A308S	3 1/2 in.		4.41	8.35	5.12	11.42	12.87	14.96	3.39	1.54	7/8	1.46	4.29	2.60	0.24	0.91	4.02	5.20	56	
QASN18A090S QAASN18A090S	90 mm	22220	125	241	152	319	366	410	101	50	24	41	126	75	10	25	117	150	35.9	
QASN20A315S QAASN20A315S	3 15/16 in.		4.92	9.49	5.98	12.56	14.41	16.14	3.98	1.97	7/8	1.61	4.96	2.95	0.39	0.98	4.61	5.91	79	
QASN20A100S QAASN20A100S	100 mm	22222	140	255	160	332	365	410	105	39	24	–	133	80	–	28	–	160	35.9	
QAASN22A110S	110 mm		5.51	10.04	6.30	13.07	14.37	16.14	4.13	1.54	7/8	–	5.24	3.15	–	1.10	–	6.30	79	
QAASN22A407S	4 7/16 in.	22222	150	265	160	367	400	445	105	49	24	–	133	80	–	28	–	160	40.0	
QAASN22A408S	4 1/2 in.		5.91	10.43	6.30	14.45	15.75	17.52	4.13	1.93	7/8	–	5.24	3.15	–	1.10	–	6.30	88	
QAASN22A115S	115 mm	22226	150	282	175	402	435	500	113	49	30	–	151	94	–	38	–	188	40.0	
QAASN26A125S	125 mm		5.91	11.1	6.89	15.83	17.13	19.69	4.45	1.93	1 1/4	–	5.94	3.7	–	1.5	–	7.4	88	
QAASN26A415S	4 15/16 in.	22226	150	282	175	402	435	500	113	49	30	–	151	94	–	38	–	188	40.0	
QAASN26A500S	5 in.		5.91	11.1	6.89	15.83	17.13	19.69	4.45	1.93	1 1/4	–	5.94	3.7	–	1.5	–	7.4	88	
QAASN26A130S	130 mm																			

⁽¹⁾Bearing part numbers use QA to designate single-collar units (use S_A and R_A dimensions) and QAA to designate double-collar units (use S_{AA} and R_{AA} dimensions).

QAAPXT 5000 SERIES TWO-BOLT PILLOW BLOCKS

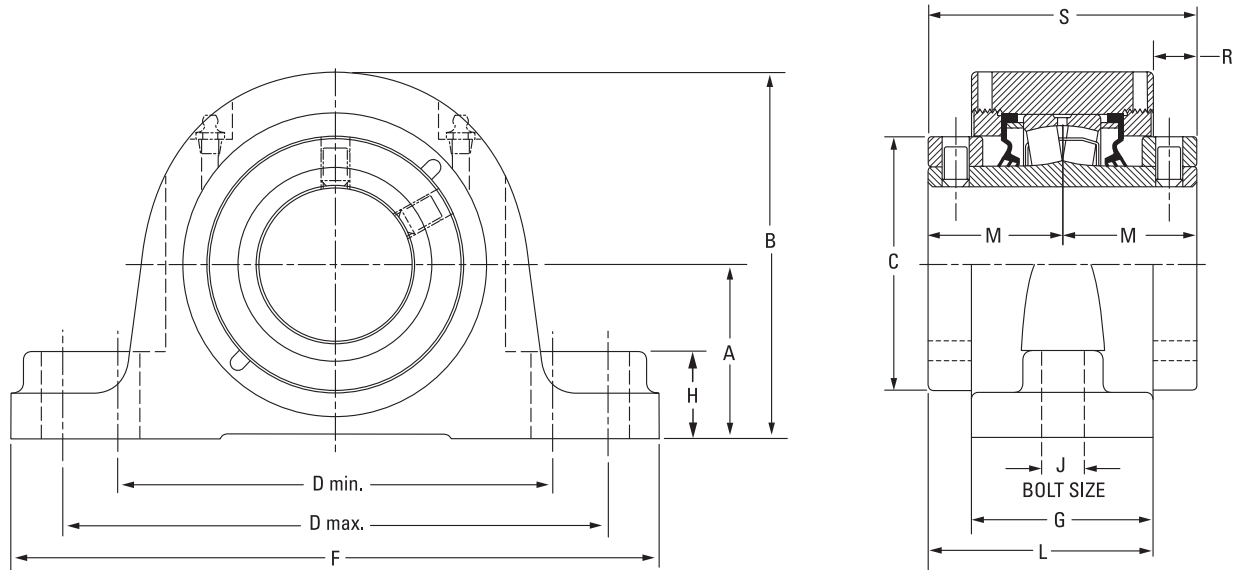

Bearing Part No.	Shaft Dia.	Bearing No.	A	B	C	D min.	D max.	F	G	H	J	L	M	R	S	Wt.
	mm in.		mm in.	mm in.	mm in.	mm in.	mm in.	mm in.	mm in.	mm in.	mm in.	mm in.	mm in.	mm in.	mm in.	kg lbs.
QAAPXT13A060S	60 mm	22213	76.2 3.00	153.7 6.05	96.8 3.81	194.6 7.66	223.0 8.78	285.8 11.25	73.7 2.90	35.1 1.38	20 ¾	91.4 3.60	54.6 2.15	17.8 0.70	109.2 4.30	10.0 22
QAAPXT13A207S	2 7/16 in.															
QAAPXT13A208S	2 1/2 in.															
QAAPXT13A065S	65 mm															
QAAPXT15A211S	2 11/16 in.	22215	88.9 3.50	173.7 6.84	109.0 4.29	230.1 9.06	265.2 10.44	330.2 13.00	75.7 2.98	35.1 1.38	24 7/8	98.0 3.86	60.2 2.37	22.4 0.88	120.4 4.74	12.7 28
QAAPXT15A212S	2 ¾ in.															
QAAPXT15A070S	70 mm															
QAAPXT15A215S	2 15/16 in.															
QAAPXT15A300S	3 in.															
QAAPXT15A075S	75 mm															

SPHERICAL ROLLER BEARING SOLID-BLOCK HOUSED UNITS

CL SERIES • QAPF AND QAAPF FOUR-BOLT PILLOW BLOCKS

QAPF AND QAAPF FOUR-BOLT PILLOW BLOCKS

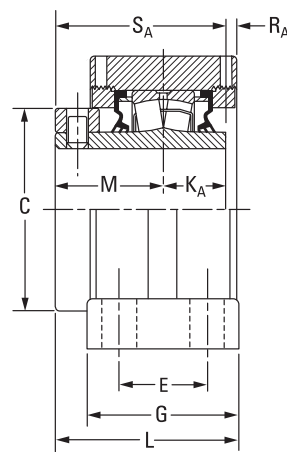
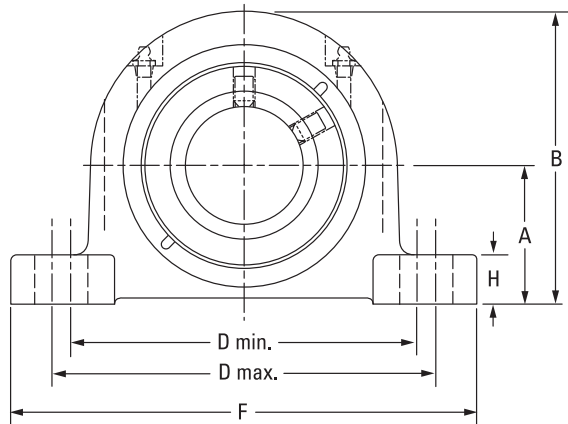
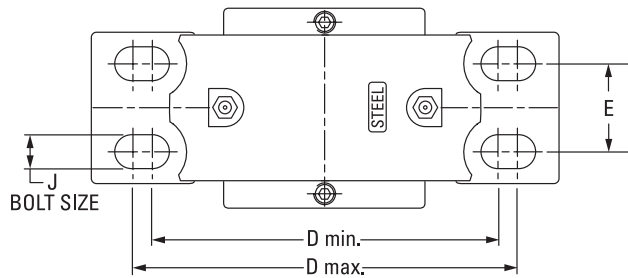

QA Single-Collar Unit

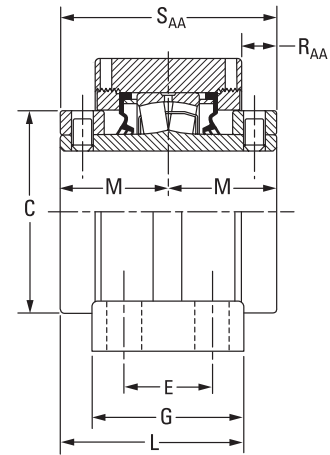

QAA Double-Collar Unit

Bearing Part No. ⁽¹⁾	Shaft Dia.	Bearing No.	A	B	C	D min.	D max.	E	F	G	H	J	K _A	L	M	R _A	R _{AA}	S _A	S _{AA}	Wt.
	mm in.		mm in.	mm in.	mm in.	mm in.	mm in.	mm in.	mm in.	mm in.	mm in.	mm in.	mm in.	mm in.	mm in.	mm in.	mm in.	mm in.	mm in.	kg lbs.
QAPF13A060S QAAPF13A060S	60 mm	22213	69.9 2.75	147.3 5.80	96.8 3.81	174.8 6.88	193.8 7.63	44.5 1.75	235.0 9.25	76.2 3.00	24.9 0.98	16 5/8	31.5 1.24	92.7 3.65	54.6 2.15	5.3 0.21	17.8 0.70	86.1 3.39	109.2 4.30	9.1 20
QAPF13A207S QAAPF13A207S	2 7/16 in.																			
QAPF13A208S QAAPF13A208S	2 1/2 in.																			
QAPF13A065S QAAPF13A065S	65 mm																			
QAPF15A211S QAAPF15A211S	2 11/16 in.	22215	82.6 3.25	167.6 6.60	109.0 4.29	193.0 7.60	231.1 9.10	47.8 1.88	265.2 10.44	79.5 3.13	32.8 1.29	16 5/8	31.8 1.25	100.1 3.94	60.2 2.37	6.1 0.24	22.4 0.88	91.9 3.62	120.4 4.74	12.2 27
QAPF15A212S QAAPF15A212S	2 3/4 in.																			
QAPF15A070S QAAPF15A070S	70 mm																			
QAPF15A215S QAAPF15A215S	2 15/16 in.																			
QAPF15A300S QAAPF15A300S	3 in.																			
QAPF15A075S QAAPF15A075S	75 mm																			

⁽¹⁾Bearing part numbers use QA to designate single-collar units (use S_A and R_A dimensions) and QAA to designate double-collar units (use S_{AA} and R_{AA} dimensions).

Continued on next page.

SPHERICAL ROLLER BEARING SOLID-BLOCK HOUSED UNITS

CL SERIES • QAPF AND QAAPF FOUR-BOLT PILLOW BLOCKS

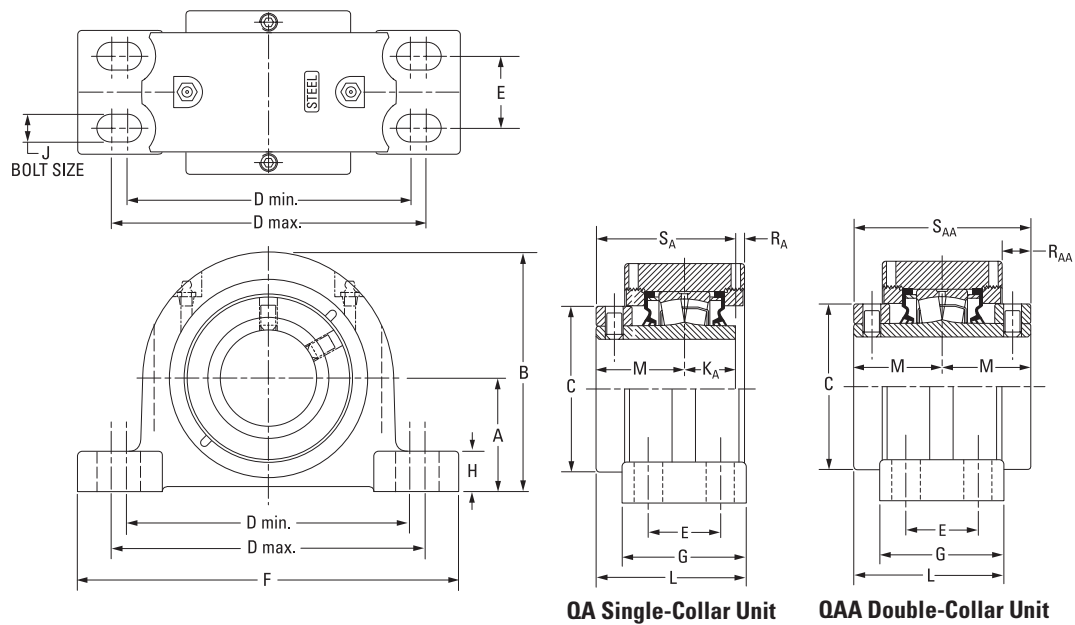

Continued from previous page.

Bearing Part No. ⁽¹⁾	Shaft Dia.	Bearing No.	A	B	C	D min.	D max.	E	F	G	H	J	K _A	L	M	R _A	R _{AA}	S _A	S _{AA}	Wt.		
			mm in.	mm in.	mm in.	mm in.	mm in.	mm in.	mm in.	mm in.	mm in.	mm in.	mm in.	mm in.	mm in.	mm in.	mm in.	mm in.	mm in.	mm in.	mm in.	kg lbs.
QAPF18A303S QAAPF18A303S	3 3/16 in.	22218																				
QAPF18A304S QAAPF18A304S	3 1/4 in.																					
QAPF18A080S QAAPF18A080S	80 mm		95.3 3.75	195.3 7.69	130.3 5.13	225.6 8.88	276.4 10.88	50.8 2.00	312.4 12.30	95.3 3.75	39.6 1.56	20 3/4	36.6 1.44	113.5 4.47	65.8 2.59	7.9 0.31	21.3 0.84	102.4 4.03	131.6 5.18	22.2 49		
QAPF18A085S QAAPF18A085S	85 mm																					
QAPF18A307S QAAPF18A307S	3 7/16 in.																					
QAPF18A308S QAAPF18A308S	3 1/2 in.																					
QAPF18A090S QAAPF18A090S	90 mm																					
QAPF20A315S QAAPF20A315S	3 15/16 in.		22220	108.0 4.25	223.0 8.78	152.4 6.00	276.4 10.88	339.9 13.38	57.2 2.25	378.0 14.88	109.5 4.31	35.6 1.40	20 3/4	41.4 1.63	130.3 5.13	75.4 2.97	8.9 0.35	25.1 0.99	116.6 4.59	150.9 5.94	30.4 67	
QAPF20A400S QAAPF20A400S	4 in.																					
QAPF20A100S QAAPF20A100S	100 mm																					
QAAPF22A110S	110 mm	22222	120.7 4.75	233.4 9.19	160.0 6.30	301.8 11.88	368.3 14.50	63.5 2.50	409.7 16.13	120.7 4.75	40.1 1.58	20 3/4	-	140.0 5.51	79.5 3.13	-	28.7 1.13	-	158.8 6.25	37.2 82		
QAAPF22A407S	4 7/16 in.																					
QAAPF22A408S	4 1/2 in.																					
QAAPF22A115S	115 mm	22226	139.7 5.50	279.7 11.01	175.0 6.89	349.3 13.75	403.4 15.88	69.9 2.75	444.5 17.50	128.0 5.04	39.1 1.54	24 7/8	-	158.5 6.24	94.5 3.72	-	36.8 1.45	-	189.0 7.44	60.8 134		
QAAPF26A125S	125 mm																					
QAAPF26A415S	4 15/16 in.																					
QAAPF26A500S	5 in.																					
QAAPF26A130S	130 mm																					

⁽¹⁾Bearing part numbers use QA to designate single-collar units (use S_A and R_A dimensions) and QAA to designate double-collar units (use S_{AA} and R_{AA} dimensions).

SPHERICAL ROLLER BEARING SOLID-BLOCK HOUSED UNITS

CL SERIES • QAPR AND QAAPR FOUR-BOLT PILLOW BLOCKS

QAPR AND QAAPR FOUR-BOLT PILLOW BLOCKS

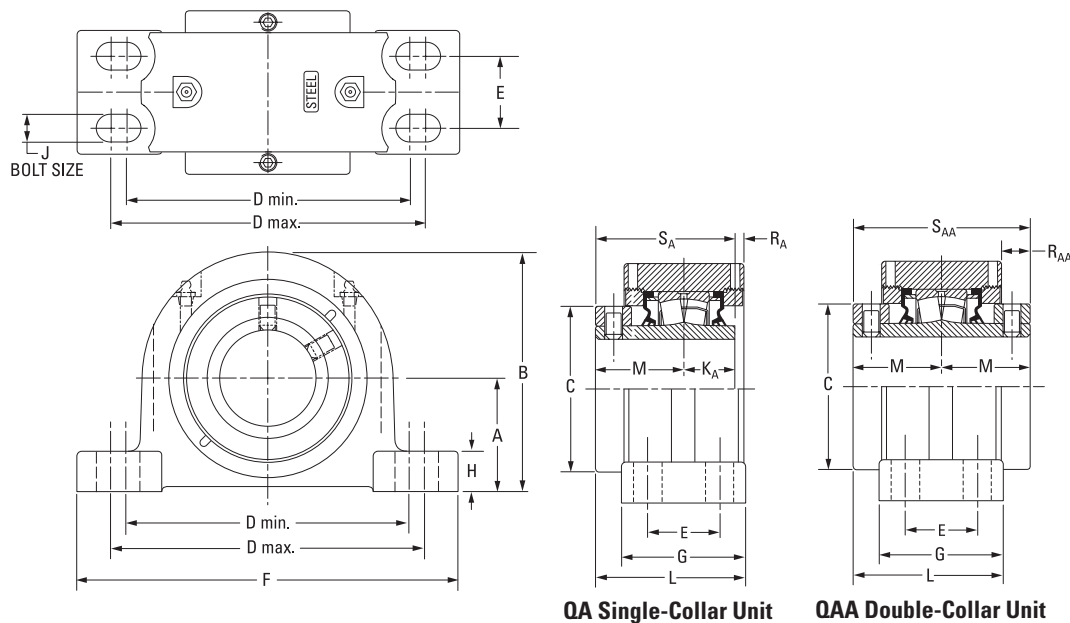

QA Single-Collar Unit

QAA Double-Collar Unit

Bearing Part No. ⁽¹⁾	Shaft Dia.	Bearing No.	A	B	C	D min.	D max.	E	F	G	H	J	K _A	L	M	R _A	R _{AA}	S _A	S _{AA}	Wt.	
	mm in.		mm in.	mm in.	mm in.	mm in.	mm in.	mm in.	mm in.	mm in.	mm in.	mm in.	mm in.	mm in.	mm in.	mm in.	mm in.	mm in.	mm in.	kg lbs.	
QAPR13A060S QAAPR13A060S	60 mm	22213	69.9 2.75	147.3 5.80	96.8 3.81	181.1 7.13	222.3 8.75	47.8 1.88	260.4 10.25	82.6 3.25	24.9 0.98	16 5/8	31.5 1.24	95.8 3.77	54.6 2.15	5.3 0.21	17.8 0.70	86.1 3.39	109.2 4.30	9.1 20	
QAPR13A207S QAAPR13A207S	2 7/16 in.																				
QAPR13A208S QAAPR13A208S	2 1/2 in.																				
QAPR13A065S QAAPR13A065S	65 mm																				
QAPR15A211S QAAPR15A211S	2 11/16 in.	22215	79.5 3.13	164.3 6.47	109.0 4.29	203.2 8.00	243.8 9.60	54.1 2.13	275.1 10.83	85.9 3.38	29.5 1.16	16 5/8	31.8 1.25	102.1 4.02	60.2 2.37	6.1 0.24	22.4 0.88	91.9 3.62	120.4 4.74	12.2 27	
QAPR15A212S QAAPR15A212S	2 3/4 in.																				
QAPR15A070S QAAPR15A070S	70 mm																				
QAPR15A215S QAAPR15A215S	2 15/16 in.																				
QAPR15A300S QAAPR15A300S	3 in.	22218	95.3 3.75	195.3 7.69	130.3 5.13	235.0 9.25	285.8 11.25	60.5 2.38	346.2 13.63	95.3 3.75	39.6 1.56	20 3/4	36.6 1.44	113.5 4.47	65.8 2.59	7.9 0.31	21.3 0.84	102.4 4.03	131.6 5.18	22.2 49	
QAPR18A303S QAAPR18A303S	3 3/16 in.																				
QAPR18A304S QAAPR18A304S	3 1/4 in.																				
QAPR18A080S QAAPR18A080S	80 mm																				
QAPR18A085S QAAPR18A085S	85 mm																				
QAPR18A307S QAAPR18A307S	3 7/16 in.																				
QAPR18A308S QAAPR18A308S	3 1/2 in.																				
QAPR18A090S QAAPR18A090S	90 mm																				

⁽¹⁾Bearing part numbers use QA to designate single-collar units (use S_A and R_A dimensions) and QAA to designate double-collar units (use S_{AA} and R_{AA} dimensions).

QAAPX 5000 SERIES FOUR-BOLT PILLOW BLOCKS

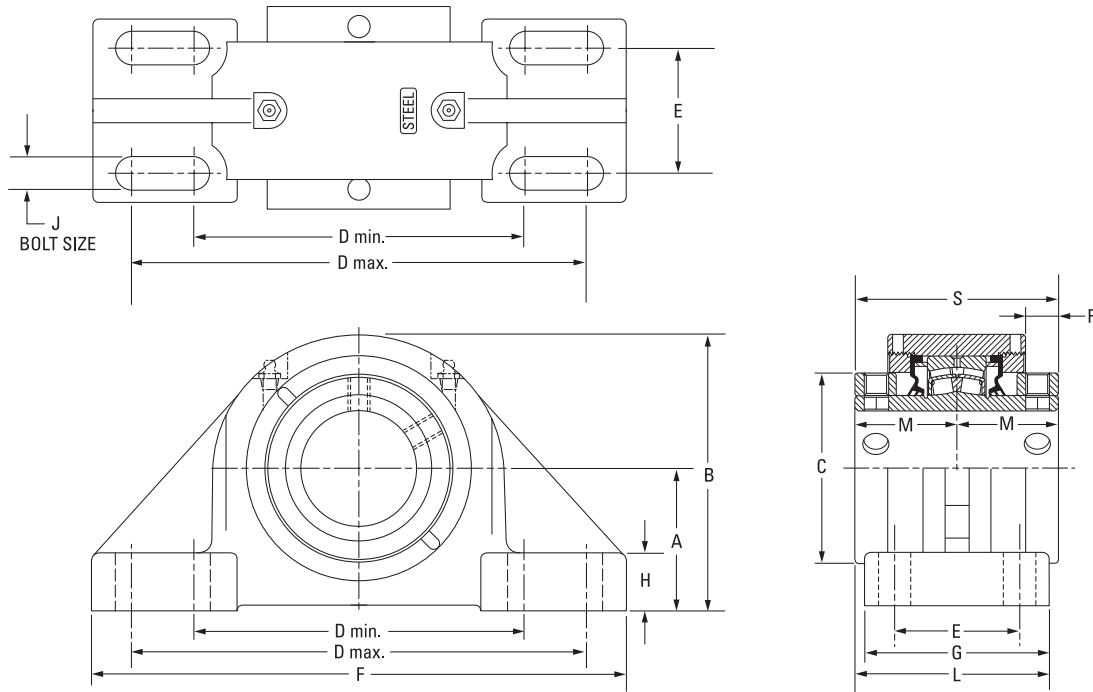

Bearing Part No. ⁽¹⁾	Shaft Dia.	Bearing No.	A	B	C	D min.	D max.	E	F	G	H	J	L	M	R	S	Wt.	
			mm in.	mm in.	mm in.	mm in.	mm in.	mm in.	mm in.	mm in.	mm in.	mm in.	mm in.	mm in.	mm in.	mm in.	mm in.	mm in.
QAAPX13A060S	60 mm	22213	76.2 3.00	153.7 6.05	96.8 3.81	176.3 6.94	242.8 9.56	66.8 2.63	285.8 11.25	98.6 3.88	31.0 1.22	20 ¾	103.9 4.09	54.6 2.15	17.8 0.70	109.2 4.30	13.2 29	
QAAPX13A207S	2 7/16 in.																	
QAAPX13A208S	2 1/2 in.																	
QAAPX13A065S	65 mm	22215	88.9 3.50	173.5 6.83	109.0 4.29	230.1 9.06	265.2 10.44	69.9 2.75	330.2 13.00	108.0 4.25	39.1 1.54	20 ¾	114.3 4.50	60.2 2.37	21.3 0.84	120.4 4.74	20.4 45	
QAAPX15A211S	2 11/16 in.																	
QAAPX15A212S	2 ¾ in.																	
QAAPX15A070S	70 mm	22218	101.6 4.00	201.2 7.92	130.3 5.13	274.6 10.81	309.6 12.19	76.2 3.00	381.0 15.00	120.7 4.75	38.1 1.50	20 ¾	126.2 4.97	65.8 2.59	21.3 0.84	131.6 5.18	29.0 64	
QAAPX18A303S	3 3/16 in.																	
QAAPX18A304S	3 ¼ in.																	
QAAPX18A080S	80 mm	22220	127.0 5.00	239.8 9.44	152.4 6.00	317.5 12.50	355.6 14.00	88.9 3.50	425.5 16.75	139.7 5.50	41.4 1.63	24 7/8	145.0 5.71	75.2 2.96	25.4 1.00	150.4 5.92	44.9 99	
QAAPX18A085S	85 mm																	
QAAPX18A307S	3 7/16 in.																	
QAAPX18A308S	3 1/2 in.	22222	146.1 5.75	273.8 10.78	159.8 6.29	354.1 13.94	395.2 15.56	101.6 4.00	469.9 18.50	158.8 6.25	45.7 1.80	24 1	158.8 6.25	79.5 3.13	28.7 1.13	158.8 6.25	63.0 139	
QAAPX22A110S	110 mm																	
QAAPX22A407S	4 7/16 in.																	
QAAPX22A408S	4 1/2 in.	22226	155.7 6.13	283.2 11.15	174.8 6.88	387.4 15.25	425.5 16.75	108.0 4.25	514.4 20.25	171.5 6.75	50.8 2.00	28.6 1 1/8	180.3 7.10	94.5 3.72	37.3 1.47	189.0 7.44	67.6 149	
QAAPX26A115S	115 mm																	
QAAPX26A125S	125 mm																	
QAAPX26A415S	4 15/16 in.																	
QAAPX26A500S	5 in.																	
QAAPX26A130S	130 mm																	

⁽¹⁾Bearing part numbers use QA to designate single-collar units (use S_A and R_A dimensions) and QAA to designate double-collar units (use S_{AA} and R_{AA} dimensions).

SPHERICAL ROLLER BEARING SOLID-BLOCK HOUSED UNITS

CL SERIES • QAC AND QAAC PILOTED FLANGE CARTRIDGES

QAC AND QAAC PILOTED FLANGE CARTRIDGES

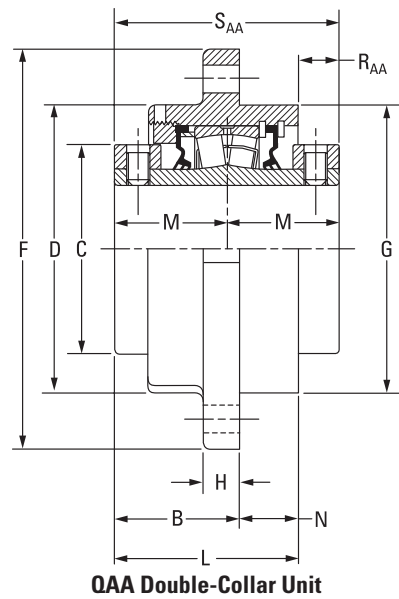
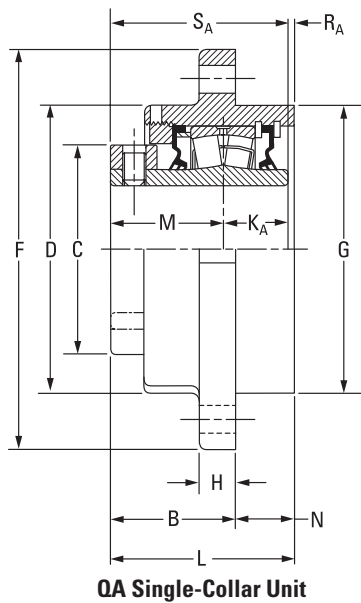
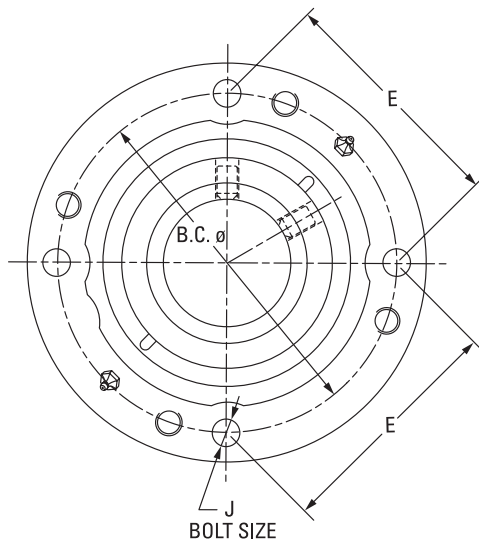

Bearing Part No. ⁽¹⁾	Shaft Dia.	Bearing No.	B _{FIX}	B _{EXP}	B.C.	C	D	E	F	G ⁽²⁾	H	J	K _A	L _{FIX}	L _{EXP}	M	N	R _A	R _{AA}	S _A	S _{AA}	Wt.	
	mm in.		mm in.	mm in.	mm in.	mm in.	mm in.	mm in.	mm in.	mm in.	mm in.	mm in.	mm in.	mm in.	mm in.	mm in.	mm in.	mm in.	mm in.	mm in.	mm in.	mm in.	kg lbs.
QAC08A035S	35 mm	22208	49.8	51.8	111.3	60.5	92.2	78.5	133.4	92.1	12.7	10	25.4	73.7	75.7	44.5	23.9	3.8	-	69.9	-	3.6	
QAC08A107S	1 7/16 in.		1.96	2.04	4.38	2.38	3.63	3.09	5.25	3.625	0.50	7/16	1.00	2.90	2.98	1.75	0.94	0.15	-	2.75	-	8	
QAC08A108S	1 1/2 in.																						
QAC09A040S	40 mm	22209	54.6	56.6	130.3	66.8	111.3	91.9	155.7	108.0	12.7	10	25.4	77.0	78.2	47.8	22.4	3.8	-	73.2	-	4.1	
QAC09A111S	1 11/16 in.		2.15	2.23	5.13	2.63	4.38	3.62	6.13	4.250	0.50	7/16	1.00	3.03	3.08	1.88	0.88	0.15	-	2.88	-	9	
QAC09A112S	1 3/4 in.																						
QAC09A045S	45 mm	22210	50.5	52.6	136.7	73.2	113.5	96.5	162.1	114.3	16.0	10	25.4	77.5	79.5	47.5	26.9	4.6	18.5	72.9	95.3	4.5	
QAC10A115S QAAC10A115S	1 15/16 in.		1.99	2.07	5.38	2.88	4.47	3.80	6.38	4.500	0.63	7/16	1.00	3.05	3.13	1.87	1.06	0.18	0.73	2.87	3.75	10	
QAC10A050S QAAC10A050S	50 mm																						
QAC11A203S QAAC11A203S	2 3/16 in.	22211	54.4	56.4	152.4	82.6	127.0	107.7	185.4	127.0	14.7	12	28.7	83.1	85.1	50.8	28.7	3.6	18.5	79.5	101.6	5.9	
QAC11A204S QAAC11A204S	2 1/4 in.		2.14	2.22	6.00	3.25	5.00	4.24	7.30	5.000	0.58	1/2	1.13	3.27	3.35	2.00	1.13	0.14	0.73	3.13	4.00	13	
QAC11A055S QAAC11A055S	55 mm																						
QAC13A060S QAAC13A060S	60 mm	22213	60.5	62.5	165.1	96.8	139.7	116.8	193.8	139.7	17.5	12	31.5	88.9	90.9	54.6	28.7	3.0	20.3	86.1	109.2	7.3	
QAC13A207S QAAC13A207S	2 7/16 in.		2.38	2.46	6.50	3.81	5.50	4.60	7.63	5.500	0.69	1/2	1.24	3.50	3.58	2.15	1.13	0.12	0.80	3.39	4.30	16	
QAC13A208S QAAC13A208S	2 1/2 in.																						
QAC13A065S QAAC13A065S	65 mm																						

⁽¹⁾Bearing part numbers use QA to designate single-collar units (use S_A and R_A dimensions) and QAA to designate double-collar units (use S_{AA} and R_{AA} dimensions).

⁽²⁾Pilot tolerance: +0/-0.051 mm (+0/-0.002 in.).

⁽³⁾Six-bolt housing.

Continued on next page.

SPHERICAL ROLLER BEARING SOLID-BLOCK HOUSED UNITS

CL SERIES • QAC AND QAAC PILOTED FLANGE CARTRIDGES

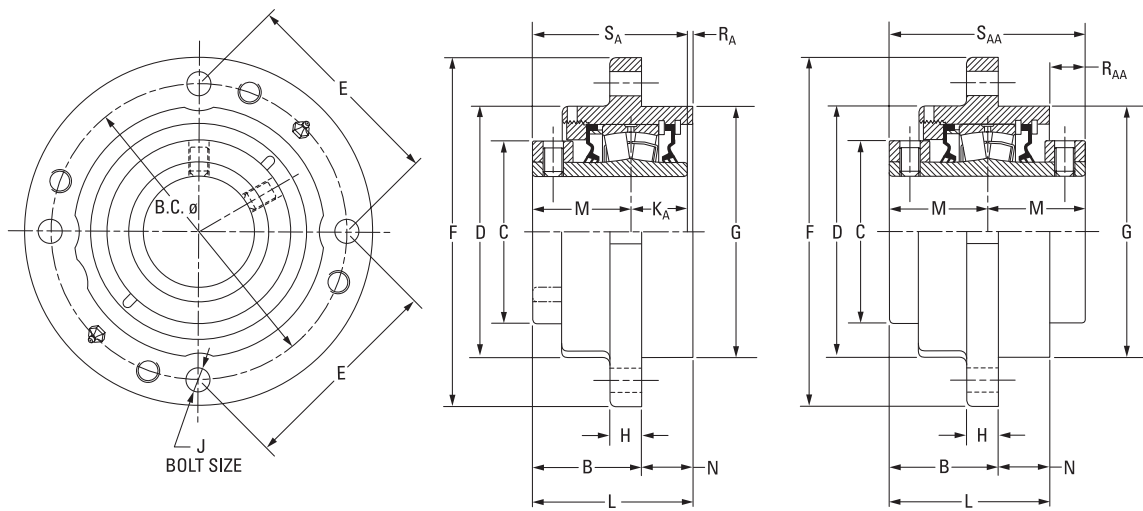

QA Single-Collar Unit

QAA Double-Collar Unit

Continued from previous page.

Bearing Part No. ⁽¹⁾	Shaft Dia.	Bearing No.	B _{FIX}	B _{EXP}	B.C.	C	D	E	F	G ⁽²⁾	H	J	K _A	L _{FIX}	L _{EXP}	M	N	R _A	R _{AA}	S _A	S _{AA}	Wt.																					
	mm in.		mm in.	mm in.	mm in.	mm in.	mm in.	mm in.	mm in.	mm in.	mm in.	mm in.	mm in.	mm in.	mm in.	mm in.	mm in.	mm in.	mm in.	mm in.	mm in.	mm in.	kg lbs.																				
QAC15A211S QAAC15A211S	2 1 ¹ / ₁₆ in.	22215	62.5 2.46	64.5 2.54	190.5 7.50	109.0 4.29	162.1 6.38	134.6 5.30	222.3 8.75	161.9 6.375	20.6 0.81	16 5/8	31.8 1.25	94.2 3.71	96.3 3.79	60.2 2.37	31.8 1.25	2.3 0.09	21.6 0.85	91.9 3.62	120.4 4.74	10.0 22																					
QAC15A212S QAAC15A212S	2 3/4 in.																																										
QAC15A070S QAAC15A070S	70 mm																																										
QAC15A215S QAAC15A215S	2 15/16 in.																																										
QAC15A300S QAAC15A300S	3 in.																																										
QAC15A075S QAAC15A075S	75 mm																																										
QAC18A303S QAAC18A303S	3 3/16 in.																						22218	73.2 2.88	75.2 2.96	219.2 8.63	130.3 5.13	187.5 7.38	154.9 6.10	262.6 10.34	187.3 7.375	25.4 1.00	20 3/4	36.6 1.44	106.4 4.19	108.5 4.27	65.8 2.59	33.3 1.31	4.1 0.16	25.1 0.99	102.4 4.03	131.6 5.18	14.5 32
QAC18A304S QAAC18A304S	3 1/4 in.																																										
QAC18A080S QAAC18A080S	80 mm																																										
QAC18A085S QAAC18A085S	85 mm																																										
QAC18A307S QAAC18A307S	3 7/16 in.																																										
QAC18A308S QAAC18A308S	3 1/2 in.																																										
QAC18A090S QAAC18A090S	90 mm																																										
QAC20A315S QAAC20A315S	3 15/16 in.	22220	72.1 2.84	74.2 2.92	238.3 9.38	152.4 6.00	206.5 8.13	168.4 6.63	276.4 10.88	206.4 8.125	25.4 1.00	20 3/4	41.4 1.63	126.0 4.96	128.0 5.04	75.4 2.97	54.1 2.13	9.4 0.37	24.9 0.98	116.6 4.59	150.9 5.94	19.5 43																					
QAC20A400S QAAC20A400S	4 in.																																										
QAC20A100S QAAC20A100S	100 mm																																										
QAAC22A110S	110 mm																																										
QAAC22A407S ⁽³⁾	4 7/16 in.	22222	78.0 3.07	80.0 3.15	298.5 11.75 ⁽³⁾	160.0 6.30	254.0 10.00	149.4 5.88 ⁽³⁾	342.9 13.50	260.4 10.250	25.4 1.00	20 3/4 ⁽³⁾	-	126.2 4.97	128.3 5.05	79.5 3.13	48.3 1.90	-	32.8 1.29	-	158.8 6.25	32.7 72																					
QAAC22A408S ⁽³⁾	4 1/2 in.																																										
QAAC22A115S ⁽³⁾	115 mm																																										

⁽¹⁾Bearing part numbers use QA to designate single-collar units (use S_A and R_A dimensions) and QAA to designate double-collar units (use S_{AA} and R_{AA} dimensions).

⁽²⁾Pilot tolerance: +0/-0.051 mm (+0/-0.002 in.).

⁽³⁾Six-bolt housing.

SPHERICAL ROLLER BEARING SOLID-BLOCK HOUSED UNITS

CL SERIES • QACW AND QAACW PILOTED FLANGE CARTRIDGES

QACW AND QAACW PILOTED FLANGE CARTRIDGES

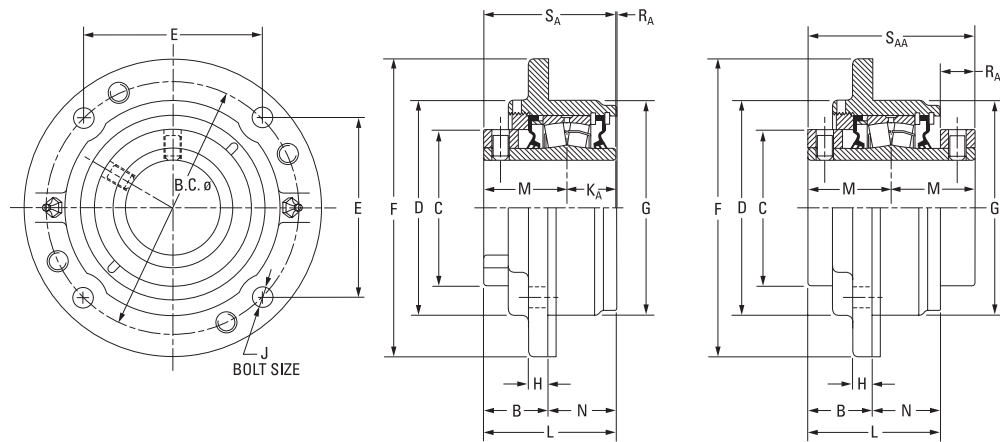

QA Single-Collar Unit

QAA Double-Collar Unit

Bearing Part No. ⁽¹⁾	Shaft Dia.	Bearing No.	B _{FIX}	B _{EXP}	B.C.	C	D	E	F	G ⁽²⁾	H	J	K _A	L _{FIX}	L _{EXP}	M	N	R _A	R _{AA}	S _A	S _{AA}	Wt.	
	mm in.		mm in.	mm in.	mm in.	mm in.	mm in.	mm in.	mm in.	mm in.	mm in.	mm in.	mm in.	mm in.	mm in.	mm in.	mm in.	mm in.	mm in.	mm in.	mm in.	mm in.	kg lbs.
QACW08A035S	35 mm	22208	38.9	40.9	111.3	60.5	92.2	78.5	133.4	92.1	12.7	10	25.4	73.7	75.7	44.5	35.1	3.8	-	69.9	-	-	3.6
QACW08A107S	1 7/16 in.		1.53	1.61	4.38	2.38	3.63	3.09	5.25	3.625	0.50	7/16	1.00	2.90	2.98	1.75	1.38	0.15	-	2.75	-	-	8
QACW08A108S	1 1/2 in.																						
QACW09A040S	40 mm	22209	38.9	40.1	130.3	66.8	111.3	91.9	155.7	108.0	10.2	10	25.4	77.0	78.2	47.8	38.1	4.1	-	73.2	-	-	4.1
QACW09A111S	1 11/16 in.		1.53	1.58	5.13	2.63	4.38	3.62	6.13	4.250	0.40	7/16	1.00	3.03	3.08	1.88	1.5	0.16	-	2.88	-	-	9
QACW09A112S	1 3/4 in.																						
QACW09A045S	45 mm	22210	35.3	37.3	136.7	73.2	113.5	96.5	162.1	114.3	9.7	10	25.4	73.4	75.4	47.5	38.1	0.5	22.6	72.9	95.3	-	4.5
QACW10A115S	1 15/16 in.		1.39	1.47	5.38	2.88	4.47	3.80	6.38	4.500	0.38	7/16	1.00	2.89	2.97	1.87	1.50	0.02	0.89	2.87	3.75	-	10
QAACW10A115S	2 in.																						
QACW10A050S	50 mm	22211	38.9	40.9	152.4	82.6	126.7	107.7	181.1	127.0	14.2	12	28.7	80.3	82.3	50.8	41.4	0.8	14.7	79.5	101.6	-	5.9
QACW11A203S	2 3/16 in.		1.53	1.61	6.00	3.25	4.99	4.24	7.13	5.000	0.56	1/2	1.13	3.16	3.24	2.00	1.63	0.03	0.58	3.13	4.00	-	13
QAACW11A203S	2 1/4 in.																						
QACW11A055S	55 mm	22213	47.2	49.3	165.1	96.8	139.7	116.8	193.8	139.7	12.7	12	31.5	90.2	92.2	54.6	42.9	4.3	19.1	86.1	109.2	-	7.3
QACW13A060S	60 mm		1.86	1.94	6.50	3.81	5.50	4.60	7.63	5.500	0.50	1/2	1.24	3.55	3.63	2.15	1.69	0.17	0.75	3.39	4.30	-	16
QAACW13A060S	2 7/16 in.																						
QACW13A207S	65 mm	22215	46.0	48.0	190.5	109.0	162.1	134.6	222.3	161.9	12.7	16	31.8	93.5	95.5	60.2	47.8	1.5	26.9	91.9	120.4	-	10.0
QACW13A208S	2 1/2 in.		1.81	1.89	7.50	4.29	6.38	5.30	8.75	6.375	0.50	5/8	1.25	3.68	3.76	2.37	1.88	0.06	1.06	3.62	4.74	-	22
QAACW13A208S	2 3/4 in.																						
QACW15A075S	75 mm																						

⁽¹⁾Bearing part numbers use QA to designate single-collar units (use S_A and R_A dimensions) and QAA to designate double-collar units (use S_{AA} and R_{AA} dimensions).

⁽²⁾Pilot tolerance: +0/-0.051 mm (+0/-0.002 in.).

⁽³⁾Six-bolt housing.

Continued on next page.

SPHERICAL ROLLER BEARING SOLID-BLOCK HOUSED UNITS

CL SERIES • QACW AND QAACW PILOTED FLANGE CARTRIDGES

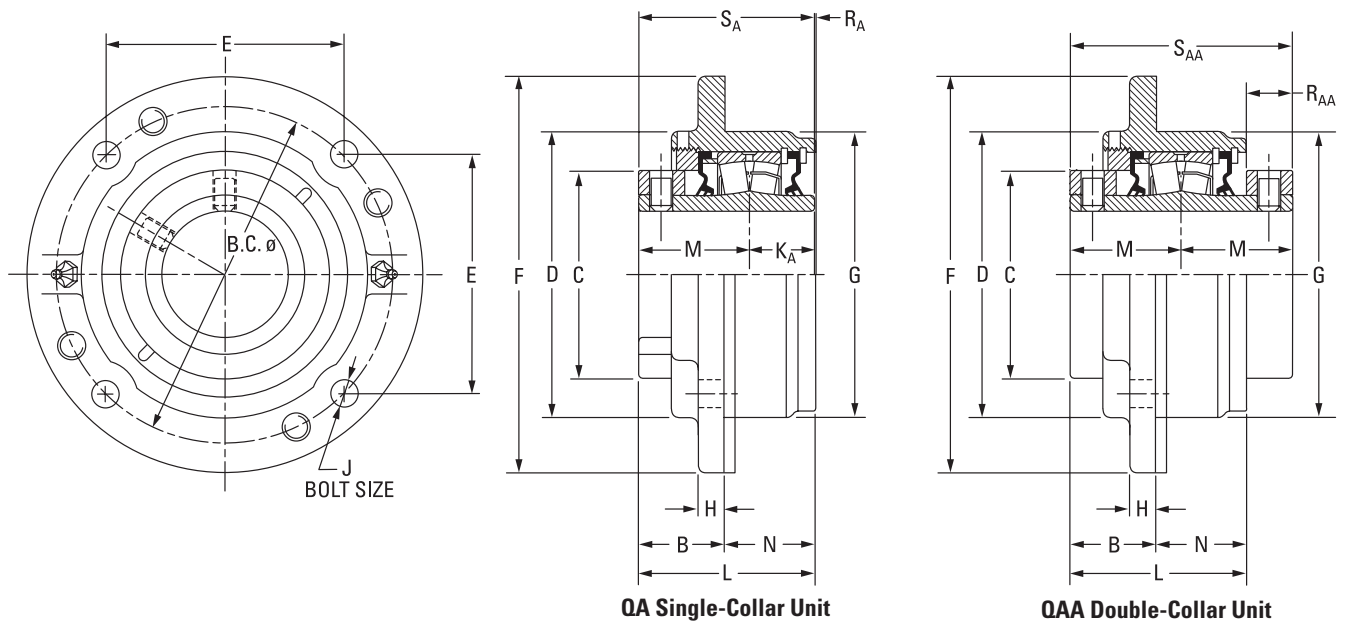

Continued from previous page.

Bearing Part No. ⁽¹⁾	Shaft Dia.	Bearing No.	B	B	B.C.	C	D	E	F	G ⁽²⁾	H	J	K _A	L	L	M	N	R _A	R _{AA}	S _A	S _{AA}	Wt.																					
			FIX	EXP																			mm	mm	mm	mm	mm	mm	mm	mm	mm	mm	mm	mm	mm	mm	mm	mm	mm	kg			
QACW18A303S QAACW18A303S	3 3/16 in.	22218	58.2 2.29	60.2 2.37	219.2 8.63	130.3 5.13	187.5 7.38	154.9 6.10	260.4 10.25	187.3 7.375	22.4 0.88	20 3/4	36.6 1.44	105.9 4.17	108.0 4.25	65.8 2.59	47.8 1.88	3.3 0.13	21.3 0.84	102.4 4.03	131.6 5.18	14.5 32																					
QACW18A304S QAACW18A304S	3 1/4 in.																																										
QACW18A080S QAACW18A080S	80 mm																																										
QACW18A085S QAACW18A085S	85 mm																																										
QACW18A307S QAACW18A307S	3 7/16 in.																																										
QACW18A308S QAACW18A308S	3 1/2 in.																																										
QACW18A090S QAACW18A090S	90 mm																																										
QACW20A315S QAACW20A315S	3 15/16 in.																						22220	65.5 2.58	67.6 2.66	238.3 9.38	152.4 6.00	206.5 8.13	168.4 6.63	276.4 10.88	206.4 8.125	25.4 1.00	20 3/4	41.4 1.63	123.4 4.86	125.5 4.94	75.4 2.97	57.9 2.28	6.9 0.27	30.2 1.19	116.6 4.59	150.9 5.94	19.5 43
QACW20A400S QAACW20A400S	4 in.																																										
QACW20A100S QAACW20A100S	100 mm																																										
QAACW22A110S	110 mm	22222	62.0 2.44	64.0 2.52	298.5 11.75 ⁽³⁾	160.0 6.30	254.0 10.00	149.4 5.88 ⁽³⁾	342.9 13.50	260.4 10.250	25.4 1.00	20 3/4 ⁽³⁾	130.0 5.12	132.1 5.20	79.5 3.13	68.3 2.69	-	28.7 1.13	-	158.8 6.25	32.7 72																						
QAACW22A407S ⁽³⁾	4 7/16 in.																																										
QAACW22A408S ⁽³⁾	4 1/2 in.																																										
QAACW26A125S ⁽³⁾	125 mm	22226	73.7 2.90	75.7 2.98	323.9 12.75 ⁽³⁾	175.0 6.89	266.7 10.50	162.1 6.38 ⁽³⁾	374.7 14.75	279.4 11.000	26.2 1.03	24 7/8 ⁽³⁾	153.2 6.03	155.2 6.11	94.5 3.72	78.0 3.07	-	35.8 1.41	-	189.0 7.44	46.3 102																						
QAACW26A415S ⁽³⁾	4 15/16 in.																																										
QAACW26A500S ⁽³⁾	5 in.																																										
QAACW26A130S ⁽³⁾	130 mm																																										

⁽¹⁾Bearing part numbers use QA to designate single-collar units (use S_A and R_A dimensions) and QAA to designate double-collar units (use S_{AA} and R_{AA} dimensions).

⁽²⁾Pilot tolerance: +0/-0.051 mm (+0/-0.002 in.).

⁽³⁾Six-bolt housing.

SPHERICAL ROLLER BEARING SOLID-BLOCK HOUSED UNITS

CL SERIES • QAF AND QAAF SQUARE FLANGE BLOCKS

QAF AND QAAF SQUARE FLANGE BLOCKS

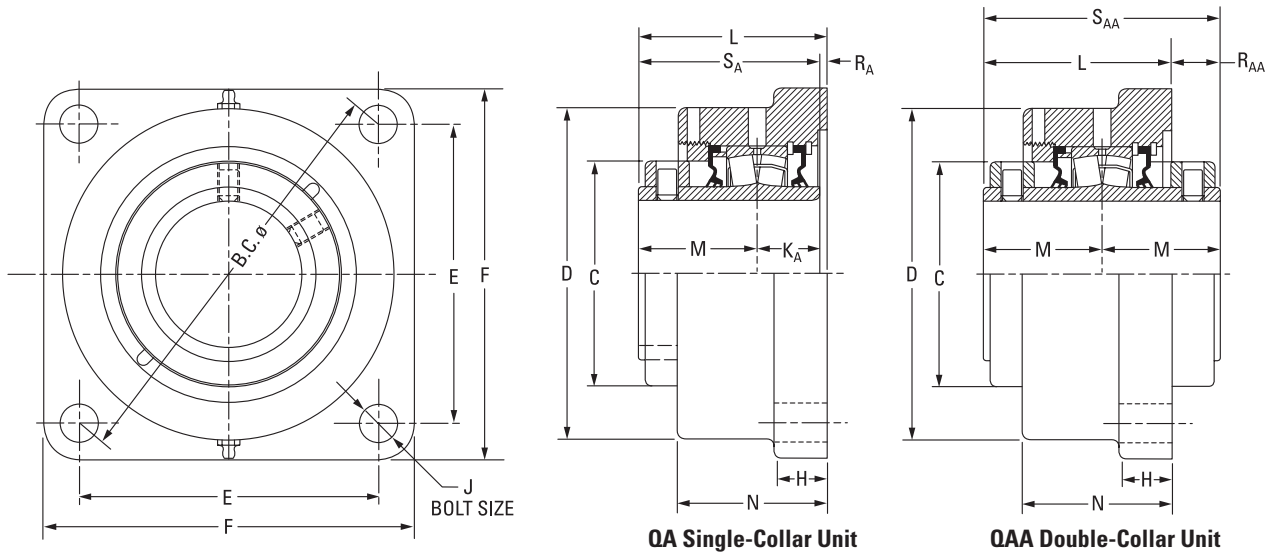

Bearing Part No. ⁽¹⁾	Shaft Dia.	Bearing No.	B.C.	C	D	E	F	H	J	K _A	L _{FIX}	L _{EXP}	M	N	R _A	R _{AA}	S _A	S _{AA}	Wt.
QAF08A035S	35 mm	22208	125.7	60.5	93.7	88.9	117.6	22.4	12	25.4	72.9	74.9	44.5	57.2	3.0	-	69.9	-	4.5
QAF08A107S	1 7/16 in.		4.95	2.38	3.69	3.50	4.63	0.88	1/2	1.00	2.87	2.95	1.75	2.25	0.12	-	2.75	-	10
QAF08A108S	1 1/2 in.	22208	148.3	60.5	108.0	104.9	136.7	22.4	12	25.4	73.7	75.7	44.5	59.4	3.8	-	69.9	-	4.5
QAF09A040S	40 mm	22209	148.3	66.8	118.4	104.9	136.7	22.4	12	25.4	79.5	81.5	47.8	63.5	6.4	-	73.2	-	5.0
QAF09A111S	1 11/16 in.		5.84	2.63	4.66	4.13	5.38	0.88	1/2	1.00	3.13	3.21	1.88	2.50	0.25	-	2.88	-	11
QAF09A112S	1 3/4 in.	22209	157.2	66.8	118.4	111.3	143.0	22.4	12	25.4	79.5	81.5	47.8	63.5	6.4	-	73.2	-	5.0
QAF09A045S	45 mm		6.19	2.63	4.66	4.38	5.63	0.88	1/2	1.00	3.13	3.21	1.88	2.50	0.25	-	2.88	-	11
QAF10A115S	1 15/16 in.	22210	157.2	73.2	120.7	111.3	139.7	22.4	12	25.4	80.8	82.8	47.5	65.0	7.9	15.2	72.9	95.3	5.0
QAAF10A115S	1 15/16 in.																		
QAF10A200S	2 in.	22210	157.2	73.2	120.7	111.3	139.7	22.4	12	25.4	80.8	82.8	47.5	65.0	7.9	15.2	72.9	95.3	5.0
QAAF10A200S	2 in.																		
QAF10A050S	50 mm	22211	175.0	82.6	130.3	124.0	157.2	25.4	16	28.7	83.1	85.1	50.8	66.8	3.8	18.5	79.5	101.6	6.4
QAAF10A050S	50 mm																		
QAF11A203S	2 3/16 in.	22211	175.0	82.6	130.3	124.0	157.2	25.4	16	28.7	83.1	85.1	50.8	66.8	3.8	18.5	79.5	101.6	6.4
QAAF11A203S	2 3/16 in.																		
QAF11A204S	2 1/4 in.	22211	175.0	82.6	130.3	124.0	157.2	25.4	16	28.7	83.1	85.1	50.8	66.8	3.8	18.5	79.5	101.6	6.4
QAAF11A204S	2 1/4 in.																		
QAF11A055S	55 mm	22213	193.0	96.8	146.1	136.7	168.4	25.4	16	31.5	89.2	91.2	54.6	72.4	3.0	20.1	86.1	109.2	7.7
QAAF11A055S	55 mm																		
QAF13A060S	60 mm	22213	193.0	96.8	146.1	136.7	168.4	25.4	16	31.5	89.2	91.2	54.6	72.4	3.0	20.1	86.1	109.2	7.7
QAAF13A060S	60 mm																		
QAF13A207S	2 7/16 in.	22213	193.0	96.8	146.1	136.7	168.4	25.4	16	31.5	89.2	91.2	54.6	72.4	3.0	20.1	86.1	109.2	7.7
QAAF13A207S	2 7/16 in.																		
QAF13A208S	2 1/2 in.	22213	193.0	96.8	146.1	136.7	168.4	25.4	16	31.5	89.2	91.2	54.6	72.4	3.0	20.1	86.1	109.2	7.7
QAAF13A208S	2 1/2 in.																		
QAF13A065S	65 mm	22213	193.0	96.8	146.1	136.7	168.4	25.4	16	31.5	89.2	91.2	54.6	72.4	3.0	20.1	86.1	109.2	7.7
QAAF13A065S	65 mm	7.60	3.81	5.75	5.38	6.63	1.00	5/8	1.24	3.51	3.59	2.15	2.85	0.12	0.79	3.39	4.30	17	

⁽¹⁾Bearing part numbers use QA to designate single-collar units (use S_A and R_A dimensions) and QAA to designate double-collar units (use S_{AA} and R_{AA} dimensions).

Continued on next page.

SPHERICAL ROLLER BEARING SOLID-BLOCK HOUSED UNITS

CL SERIES • QAF AND QAAF SQUARE FLANGE BLOCKS

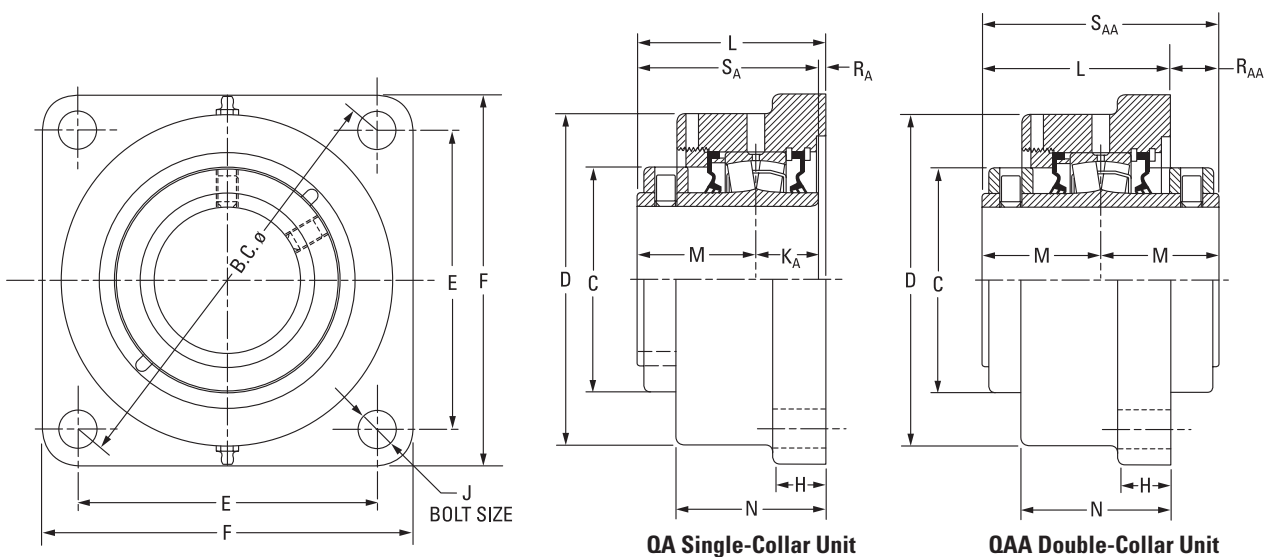

Continued from previous page.

Bearing Part No. ⁽¹⁾	Shaft Dia.	Bearing No.	B.C.	C	D	E	F	H	J	K _A	L _{FIX}	L _{EXP}	M	N	R _A	R _{AA}	S _A	S _{AA}	Wt.	
	mm in.		mm in.	mm in.	mm in.	mm in.	mm in.	mm in.	mm in.	mm in.	mm in.	mm in.	mm in.	mm in.	mm in.	mm in.	mm in.	mm in.	mm in.	kg lbs.
QAF15A211S QAAF15A211S	2 11/16 in.	22215	215.4 8.48	109.0 4.29	168.9 6.65	152.4 6.00	189.0 7.44	26.9 1.06	20 3/4	31.8 1.25	95.8 3.77	97.8 3.85	60.2 2.37	76.2 3.00	3.8 0.15	24.6 0.97	91.9 3.62	120.4 4.74	10.4 23	
QAF15A212S QAAF15A212S	2 3/4 in.																			
QAF15A070S QAAF15A070S	70 mm																			
QAF15A215S QAAF15A215S	2 15/16 in.																			
QAF15A300S QAAF15A300S	3 in.																			
QAF15A075S QAAF15A075S	75 mm																			
QAF18A303S QAAF18A303S	3 3/16 in.	22218	251.7 9.91	130.3 5.13	193.8 7.63	177.8 7.00	219.2 8.63	33.3 1.31	20 3/4	36.6 1.44	107.2 4.22	109.2 4.30	65.8 2.59	84.1 3.31	4.8 0.19	24.4 0.96	102.4 4.03	131.6 5.18	15.9 35	
QAF18A304S QAAF18A304S	3 1/4 in.																			
QAF18A080S QAAF18A080S	80 mm																			
QAF18A085S QAAF18A085S	85 mm																			
QAF18A307S QAAF18A307S	3 7/16 in.																			
QAF18A308S QAAF18A308S	3 1/2 in.																			
QAF18A090S QAAF18A090S	90 mm																			
QAF20A315S QAAF20A315S	3 15/16 in.	22220	278.4 10.96	152.4 6.00	224.0 8.82	196.9 7.75	253.2 9.97	38.1 1.50	24 7/8	41.4 1.63	126.0 4.96	128.0 5.04	75.4 2.97	103.1 4.06	9.4 0.37	24.1 0.95	116.6 4.59	150.4 5.92	24.9 55	
QAF20A400S QAAF20A400S	4 in.																			
QAF20A100S QAAF20A100S	100 mm																			
QAAF22A110S	110 mm	22222	314.5 12.38	160.0 6.30	222.3 8.75	222.3 8.75	276.4 10.88	38.1 1.50	24 7/8	-	135.6 5.34	137.7 5.42	79.5 3.13	106.9 4.21	-	23.4 0.92	-	158.8 6.25	28.6 63	
QAAF22A407S	4 7/16 in.																			
QAAF22A408S	4 1/2 in.																			
QAAF22A115S	115 mm																			

⁽¹⁾Bearing part numbers use QA to designate single-collar units (use S_A and R_A dimensions) and QAA to designate double-collar units (use S_{AA} and R_{AA} dimensions).

SPHERICAL ROLLER BEARING SOLID-BLOCK HOUSED UNITS

CL SERIES • QAFL AND QAAFL SQUARE FLANGE BLOCKS

QAFL AND QAAFL SQUARE FLANGE BLOCKS

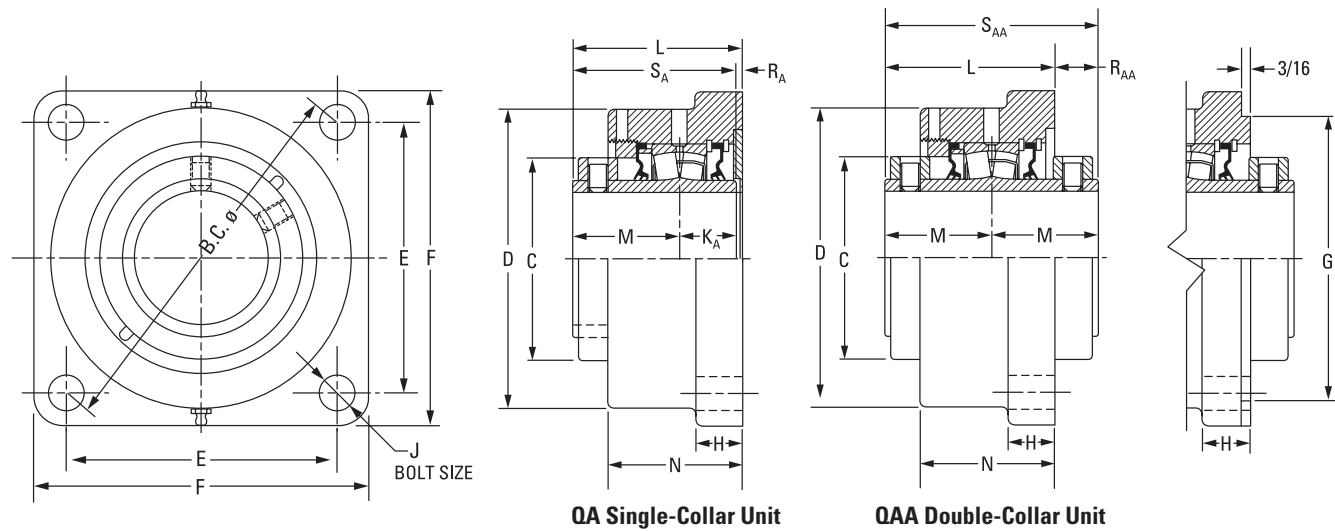

Bearing Part No. ⁽¹⁾	Shaft Dia.	Bearing No.	B.C.	C	D	E	F	G ⁽²⁾⁽³⁾⁽⁴⁾	H	J	K _A	L _{FIX}	L _{EXP}	M	N	R _A	R _{AA}	S _A	S _{AA}	Wt.
	mm in.		mm in.	mm in.	mm in.	mm in.	mm in.	mm in.	mm in.	mm in.	mm in.	mm in.	mm in.	mm in.	mm in.	mm in.	mm in.	mm in.	mm in.	kg lbs.
QAFL08A035S	35 mm	22208	127.0	60.5	93.7	89.9	117.6	N/A	22.4	12	25.4	72.9	74.9	44.5	57.2	3.0	-	69.9	-	4.5
QAFL08A107S	1 7/16 in.		5.00	2.38	3.69	3.54	4.63	N/A	0.88	1/2	1.00	2.87	2.95	1.75	2.25	0.12	-	2.75	-	10
QAFL08A108S	1 1/2 in.																			
QAFL09A040S	40 mm	22209	139.7	66.8	118.4	98.8	136.7	N/A	22.4	12	25.4	79.5	81.5	47.8	63.5	6.6	-	73.2	-	5.0
QAFL09A111S	1 11/16 in.		5.50	2.63	4.66	3.89	5.38	N/A	0.88	1/2	1.00	3.13	3.21	1.88	2.50	0.26	-	2.88	-	11
QAFL09A112S	1 3/4 in.																			
QAFL09A045S	45 mm	22210	146.1	73.2	120.7	103.4	131.8	N/A	23.1	12	25.4	80.8	82.8	47.5	62.5	7.9	15.2	72.9	95.3	5.0
QAFL10A115S	1 15/16 in.		5.75	2.88	4.75	4.07	5.19	N/A	0.91	1/2	1.00	3.18	3.26	1.87	2.46	0.31	0.60	2.87	3.75	11
QAFL10A200S	2 in.																			
QAFL10A050S	50 mm	22211	162.1	82.6	131.8	114.3	149.4	N/A	19.1	16	28.7	83.3	85.3	50.8	66.8	3.8	18.3	79.5	101.6	6.4
QAFL11A203S	2 3/16 in.		6.38	3.25	5.19	4.50	5.88	N/A	0.75	5/8	1.13	3.28	3.36	2.00	2.63	0.15	0.72	3.13	4.00	14
QAFL11A204S	2 1/4 in.																			
QAFL11A055S	55 mm	22213	171.5	96.8	146.1	121.2	157.2	N/A	25.4	16	31.5	89.2	91.2	54.6	72.6	3.0	20.1	86.1	109.2	7.7
QAFL13A060S	60 mm		6.75	3.81	5.75	4.77	6.19	N/A	1.00	5/8	1.24	3.51	3.59	2.15	2.86	0.12	0.79	3.39	4.30	17
QAFL13A207S	2 7/16 in.																			
QAFL13A208S	2 1/2 in.																			
QAFL13A065S	65 mm																			
QAFL13A065S	65 mm																			

⁽¹⁾Bearing part numbers use QA to designate single-collar units (use S_A and R_A dimensions) and QAA to designate double-collar units (use S_{AA} and R_{AA} dimensions).

⁽²⁾Pilot tolerance: +0/-0.05 mm (+0/-0.002 in.).

⁽³⁾Add (p) to the end of the housing designation in the part number to order with pilot using G dimension.

⁽⁴⁾Piloted flange blocks will be quoted (price and delivery) upon request. For optional spigot on flange side, insert the letter P as seen in the following example: QMFP**J***S.

Continued on next page.

SPHERICAL ROLLER BEARING SOLID-BLOCK HOUSED UNITS

CL SERIES • QAFL AND QAAFL SQUARE FLANGE BLOCKS

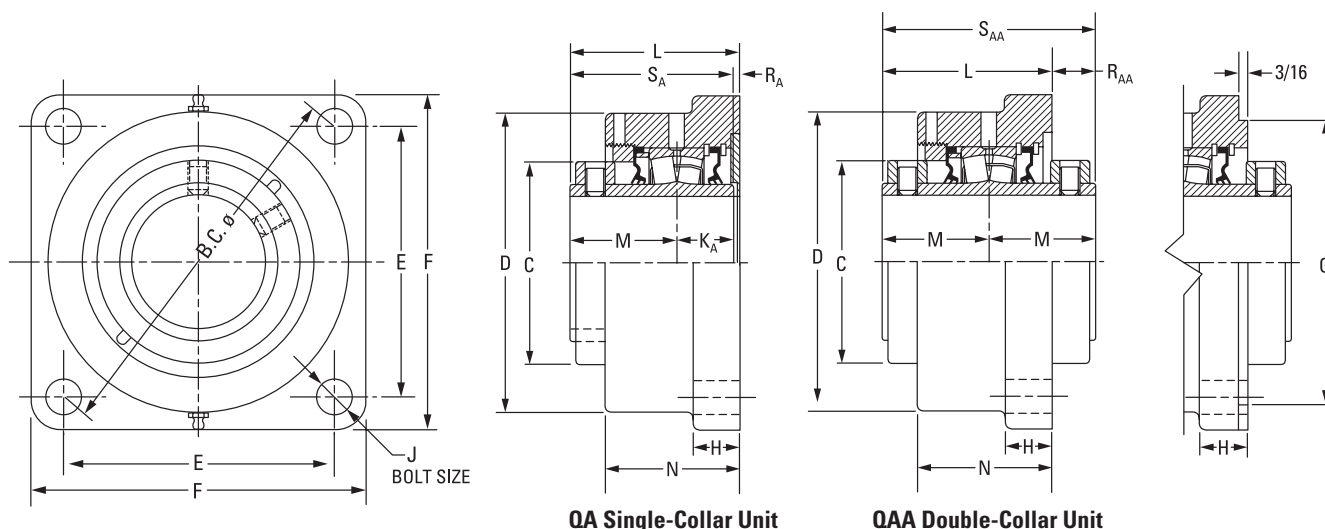

Continued from previous page.

Bearing Part No. ⁽¹⁾	Shaft Dia.	Bearing No.	B.C.	C	D	E	F	G ⁽²⁾⁽³⁾⁽⁴⁾	H	J	K _A	L _{FIX}	L _{EXP}	M	N	R _A	R _{AA}	S _A	S _{AA}	Wt.
	mm in.		mm in.	mm in.	mm in.	mm in.	mm in.	mm in.	mm in.	mm in.	mm in.	mm in.	mm in.	mm in.	mm in.	mm in.	mm in.	mm in.	mm in.	kg lbs.
QAFL15A211S QAAFL15A211S	2 11/16 in.	22215	200.2 7.88	109.0 4.29	168.4 6.63	141.2 5.56	182.6 7.19	N/A	26.9 1.06	20 3/4	31.8 1.25	95.8 3.77	97.8 3.85	60.2 2.37	74.4 2.93	3.8 0.15	24.6 0.97	91.9 3.62	120.4 4.74	10.4 23
QAFL15A212S QAAFL15A212S	2 3/4 in.																			
QAFL15A070S QAAFL15A070S	70 mm																			
QAFL15A215S QAAFL15A215S	2 15/16 in.																			
QAFL15A300S QAAFL15A300S	3 in.																			
QAFL15A075S QAAFL15A075S	75 mm																			
QAFL18A303S QAAFL18A303S	3 3/16 in.	22218	241.3 9.50	130.3 5.13	193.8 7.63	170.7 6.72	212.9 8.38	187.33 7.375	32.5 1.28	20 3/4	36.6 1.44	106.4 4.19	108.5 4.27	65.8 2.59	86.4 3.40	4.1 0.16	25.1 0.99	102.4 4.03	131.6 5.18	15.9 35
QAFL18A304S QAAFL18A304S	3 1/4 in.																			
QAFL18A080S QAAFL18A080S	80 mm																			
QAFL18A085S QAAFL18A085S	85 mm																			
QAFL18A307S QAAFL18A307S	3 7/16 in.																			
QAFL18A308S QAAFL18A308S	3 1/2 in.																			
QAFL18A090S QAAFL18A090S	90 mm	22220	273.1 10.75	152.4 6.00	229.6 9.04	193.0 7.60	241.3 9.50	215.90 8.500	38.1 1.50	24 1	41.4 1.63	132.3 5.21	134.4 5.29	75.4 2.97	104.6 4.12	15.7 0.62	18.0 0.71	116.6 4.59	150.4 5.92	24.9 55
QAFL20A315S QAAFL20A315S	3 15/16 in.																			
QAFL20A400S QAAFL20A400S	4 in.																			
QAFL20A100S QAAFL20A100S	100 mm																			

⁽¹⁾ Bearing part numbers use QA to designate single-collar units (use S_A and R_A dimensions) and QAA to designate double-collar units (use S_{AA} and R_{AA} dimensions).

⁽²⁾ Pilot tolerance: +0/-0.05 mm (+0/-0.002 in.).

⁽³⁾ Add (p) to the end of the housing designation in the part number to order with pilot using G dimension.

⁽⁴⁾ Piloted flange blocks will be quoted (price and delivery) upon request. For optional spigot on flange side, insert the letter P as seen in the following example: QMFP**J***S.

SPHERICAL ROLLER BEARING SOLID-BLOCK HOUSED UNITS

CL SERIES • QAAF 5000 SERIES FLANGE BLOCKS

QAAF 5000 SERIES FLANGE BLOCKS

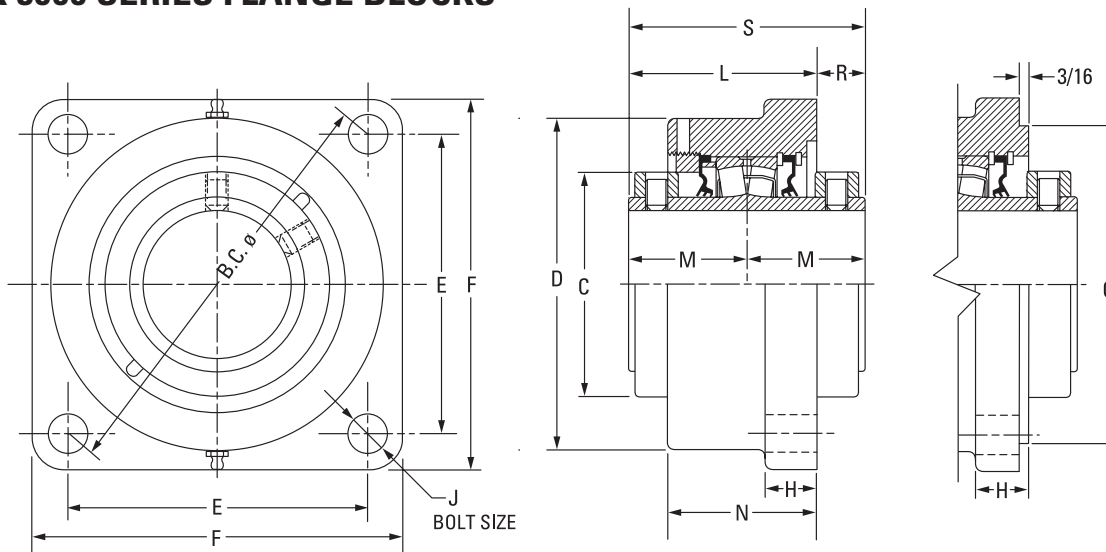

Bearing Part No.	Shaft Dia.	Bearing No.	B.C.	C	D	E	F	G ⁽¹⁾⁽²⁾⁽³⁾	H	J	L _{FIX}	L _{EXP}	M	N	R	S	Wt.
	mm in.		mm in.	mm in.	mm in.	mm in.	mm in.	mm in.	mm in.	mm in.	mm in.	mm in.	mm in.	mm in.	mm in.	mm in.	kg lbs.
QAAF10A115S	1 15/16 in.	22210	146.1	73.2	120.7	103.1	134.9	111.13	22.4	12	80.8	82.8	47.5	65.0	15.2	95.3	5.4
QAAF10A200S	2 in.		5.75	2.88	4.75	4.06	5.31	4.375	0.88	1/2	3.18	3.26	1.87	2.56	0.60	3.75	12
QAAF10A050S	50 mm																
QAAF11A203S	2 3/16 in.	22211	161.5	82.6	130.3	114.3	149.4	127.00	25.4	16	83.1	85.1	50.5	66.8	18.5	101.6	6.8
QAAF11A204S	2 1/4 in.		6.36	3.25	5.13	4.50	5.88	5.000	1.00	5/8	3.27	3.35	1.99	2.63	0.73	4.00	15
QAAF11A055S	55 mm																
QAAF13A060S	60 mm	22213	180.8	96.8	146.1	127.8	157.2	138.13	25.4	16	89.2	91.2	54.6	72.4	19.6	109.2	8.6
QAAF13A207S	2 7/16 in.		7.12	3.81	5.75	5.03	6.19	5.438	1.00	5/8	3.51	3.59	2.15	2.85	0.77	4.30	19
QAAF13A208S	2 1/2 in.																
QAAF13A065S	65 mm	22215	215.9	109.0	168.9	152.7	189.0	160.35	26.9	20	96.0	98.0	60.2	76.2	24.4	120.4	12.7
QAAF15A211S	2 11/16 in.		8.50	4.29	6.65	6.01	7.44	6.313	1.06	3/4	3.78	3.86	2.37	3.00	0.96	4.74	28
QAAF15A212S	2 3/4 in.																
QAAF15A070S	70 mm	22218	241.3	130.3	193.8	170.7	212.9	187.33	33.3	20	107.2	109.2	65.8	84.1	24.6	131.6	19.1
QAAF15A215S	2 15/16 in.		9.50	5.13	7.63	6.72	8.38	7.375	1.31	3/4	4.22	4.30	2.59	3.31	0.97	5.18	42
QAAF15A300S	3 in.																
QAAF15A075S	75 mm	22220	298.5	152.4	215.9	211.1	268.2	225.43	38.1	24	126.0	128.0	75.4	103.1	24.6	150.4	29.9
QAAF18A303S	3 3/16 in.		11.75	6.00	8.50	8.31	10.56	8.875	1.50	7/8	4.96	5.04	2.97	4.06	0.97	5.92	66
QAAF18A304S	3 1/4 in.																
QAAF18A080S	80 mm	22222	327.2	160.0	256.5	163.6	384.3	263.53	31.8	24	143.8	145.8	94.0	106.9	15.0	158.8	46.3
QAAF18A085S	85 mm		12.88 ⁽⁴⁾	6.30	10.10	6.44 ⁽⁴⁾	15.13	10.375	1.25	7/8	5.66	5.74	3.70	4.21	0.59	6.25	102
QAAF18A307S	3 7/16 in.																
QAAF18A308S	3 1/2 in.	22226	355.6	175.0	284.2	177.8	419.1	284.18	38.1	24	174.8	176.8	94.5	135.1	14.2	189.0	52.2
QAAF18A090S	90 mm		14.00 ⁽⁴⁾	6.89	11.19	7.00 ⁽⁴⁾	16.50	11.188	1.50	1	6.88	6.96	3.72	5.32	0.56	7.44	115
QAAF20A315S	3 15/16 in.																
QAAF20A400S	4 in.																
QAAF20A100S	100 mm																
QAAF22A110S	110 mm																
QAAF22A407S ⁽⁴⁾	4 7/16 in.																
QAAF22A408S ⁽⁴⁾	4 1/2 in.																
QAAF22A115S ⁽⁴⁾	115 mm																
QAAF26A125S ⁽⁴⁾	125 mm																
QAAF26A415S ⁽⁴⁾	4 15/16 in.																
QAAF26A500S ⁽⁴⁾	5 in.																
QAAF26A130S ⁽⁴⁾	130 mm																

⁽¹⁾Pilot tolerance: +0/-0.05 mm (+0/-0.002 in.).

⁽²⁾Add (p) to the end of the housing designation in the part number to order with pilot using G dimension.

⁽³⁾Piloted flange blocks will be quoted (price and delivery) upon request. For optional spigot on flange side, insert the letter P as seen in the following example: QMFP**J***S.

⁽⁴⁾Six-bolt round housing.

QAFY AND QAAFY ROUND FLANGE BLOCKS

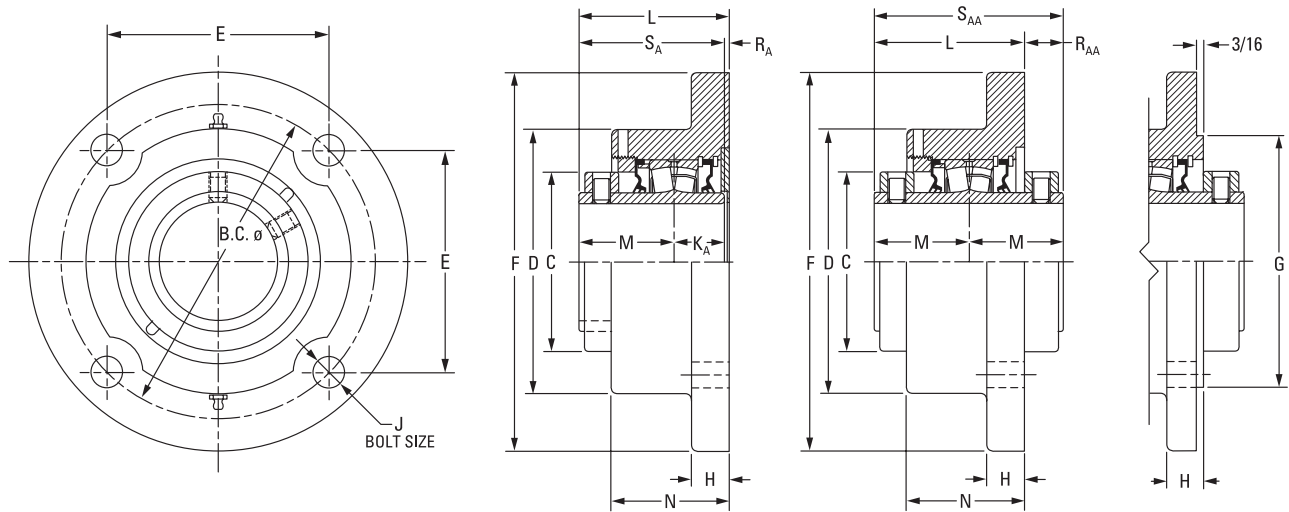

QAFY Single-Collar Unit

QAAFY Double-Collar Unit

Bearing Part No. ⁽¹⁾	Shaft Dia.	Bearing No.	B.C.	C	D	E	F	G ⁽²⁾⁽³⁾⁽⁴⁾	H	J	KA	L _{FIX}	L _{EXP}	M	N	RA	RAA	SA	SAA	Wt.
	mm in.		mm in.	mm in.	mm in.	mm in.	mm in.	mm in.	mm in.	mm in.	mm in.	mm in.	mm in.	mm in.	mm in.	mm in.	mm in.	mm in.	mm in.	kg lbs.
QAFY08A035S ⁽⁶⁾	35 mm	22208	127.0	60.5	108.0	89.9	158.8	90.50	19.1	12	25.4	73.2	75.2	44.5	57.4	3.3	-	69.9	-	4.5
QAFY08A107S ⁽⁶⁾	1 7/16 in.		5.00	2.38	4.25	3.54	6.25	3.563	0.75	1/2	1.00	2.88	2.96	1.75	2.26	0.13	-	2.75	-	10
QAFY08A108S ⁽⁶⁾	1 1/2 in.																			
QAFY09A040S	40 mm	22209	139.7	66.8	104.9	98.8	171.5	103.20	20.6	12	25.4	76.2	78.2	47.8	60.5	3.0	-	73.2	-	5.0
QAFY09A111S	1 11/16 in.		5.50	2.63	4.13	3.89	6.75	4.063	0.81	1/2	1.00	3.00	3.08	1.88	2.38	0.12	-	2.88	-	11
QAFY09A112S	1 3/4 in.																			
QAFY09A045S	45 mm	22210	146.1	73.2	115.3	103.4	177.8	111.13	19.1	12	25.4	75.9	78.0	47.5	57.2	3.0	20.1	72.9	95.3	5.4
QAFY10A115S	1 15/16 in.		5.75	2.88	4.54	4.07	7.00	4.375	0.75	1/2	1.00	2.99	3.07	1.87	2.25	0.12	0.79	2.87	3.75	12
QAAFY10A200S	2 in.																			
QAFY10A050S	50 mm	22211	162.1	82.6	130.3	114.3	196.9	127.00	19.1	16	28.7	82.3	84.3	50.8	62.0	3.0	19.3	79.5	101.6	6.8
QAAFY10A050S	50 mm		6.38	3.25	5.13	4.50	7.75	5.000	0.75	5/8	1.13	3.24	3.32	2.00	2.44	0.12	0.76	3.13	4.00	15
QAFY11A203S	2 3/16 in.																			
QAFY11A204S	2 1/4 in.	22213	171.5	96.8	146.1	121.2	206.5	138.13	23.9	16	31.5	91.2	93.2	54.6	72.4	5.1	20.6	86.1	109.2	8.6
QAAFY11A055S	55 mm		6.75	3.81	5.75	4.77	8.13	5.438	0.94	5/8	1.24	3.59	3.67	2.15	2.85	0.20	0.81	3.39	4.30	19
QAFY13A060S	60 mm																			
QAFY13A207S	2 7/16 in.	22213	171.5	96.8	146.1	121.2	206.5	138.13	23.9	16	31.5	91.2	93.2	54.6	72.4	5.1	20.6	86.1	109.2	8.6
QAAFY13A207S	2 7/16 in.		6.75	3.81	5.75	4.77	8.13	5.438	0.94	5/8	1.24	3.59	3.67	2.15	2.85	0.20	0.81	3.39	4.30	19
QAFY13A208S	2 1/2 in.																			
QAFY13A065S	65 mm	22213	171.5	96.8	146.1	121.2	206.5	138.13	23.9	16	31.5	91.2	93.2	54.6	72.4	5.1	20.6	86.1	109.2	8.6
QAAFY13A065S	65 mm		6.75	3.81	5.75	4.77	8.13	5.438	0.94	5/8	1.24	3.59	3.67	2.15	2.85	0.20	0.81	3.39	4.30	19

⁽¹⁾Bearing part numbers use QA to designate single-collar units (use SA and RA dimensions) and QAA to designate double-collar units (use SAA and RAA dimensions).

⁽²⁾Pilot tolerance: +0/-0.05 mm (+0/-0.002 in.).

⁽³⁾Add (p) to the end of the housing designation in the part number to order with pilot using G dimension.

⁽⁴⁾Piloted flange blocks will be quoted (price and delivery) upon request. For optional spigot on flange side, insert the letter P as seen in the following example: QMFP**J***S.

⁽⁵⁾Six-bolt housing.

⁽⁶⁾Three-bolt housing.

Continued on next page.

SPHERICAL ROLLER BEARING SOLID-BLOCK HOUSED UNITS

CL SERIES • QAFY AND QAAFY ROUND FLANGE BLOCKS

QAFY AND QAAFY ROUND FLANGE BLOCKS – continued

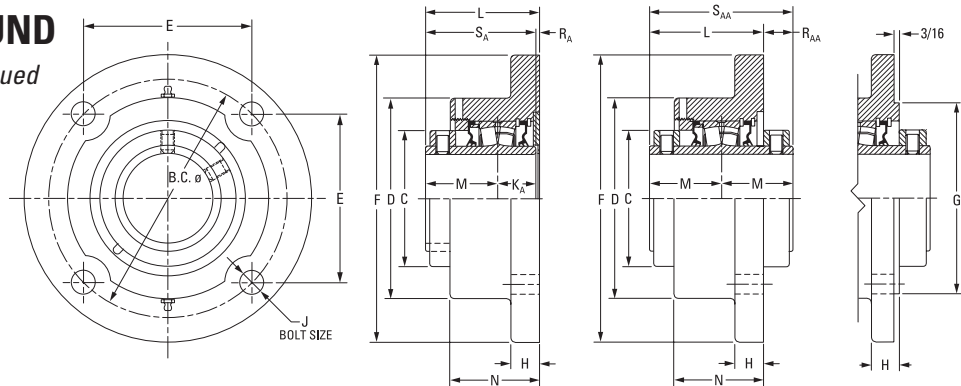

QA Single-Collar Unit QAA Double-Collar Unit

Continued from previous page.

Bearing Part No. ⁽¹⁾	Shaft Dia.	Bearing No.	B.C.	C	D	E	F	G ⁽²⁾⁽³⁾⁽⁴⁾	H	J	K _A	L _{FIX}	L _{EXP}	M	N	R _A	R _{AA}	S _A	S _{AA}	Wt.	
	mm in.		mm in.	mm in.	mm in.	mm in.	mm in.	mm in.	mm in.	mm in.	mm in.	mm in.	mm in.	mm in.	mm in.	mm in.	mm in.	mm in.	mm in.	mm in.	kg lbs.
QAFY15A211S QAAFY15A211S	2 11/16 in.	22215	200.2 7.88	109.0 4.29	168.4 6.63	141.5 5.57	241.3 9.50	160.35 6.313	23.9 0.94	20 3/4	31.8 1.25	98.3 3.87	100.3 3.95	60.2 2.37	74.4 2.93	6.4 0.25	21.8 0.86	91.9 3.62	120.4 4.74	12.7 28	
QAFY15A212S QAAFY15A212S	2 3/4 in.																				
QAFY15A070S QAAFY15A070S	70 mm																				
QAFY15A215S QAAFY15A215S	2 15/16 in.																				
QAFY15A300S QAAFY15A300S	3 in.																				
QAFY15A075S QAAFY15A075S	75 mm																				
QAFY18A303S QAAFY18A303S	3 3/16 in.																				22218
QAFY18A304S QAAFY18A304S	3 1/4 in.																				
QAFY18A080S QAAFY18A080S	80 mm																				
QAFY18A085S QAAFY18A085S	85 mm																				
QAFY18A307S QAAFY18A307S	3 7/16 in.																				
QAFY18A308S QAAFY18A308S	3 1/2 in.																				
QAFY18A090S QAAFY18A090S	90 mm																				
QAFY20A315S QAAFY20A315S	3 15/16 in.	22220	273.1 10.75	152.4 6.00	212.9 8.38	193.0 7.60	320.8 12.63	N/A	28.7 1.13	24 1	41.4 1.63	123.7 4.87	125.7 4.95	75.4 2.97	96.8 3.81	6.9 0.27	26.7 1.05	116.6 4.59	150.4 5.92	29.9 66	
QAFY20A400S QAAFY20A400S	4 in.																				
QAFY20A100S QAAFY20A100S	100 mm																				
QAAFY22A110S ⁽⁵⁾	110 mm	22222	327.2 12.88 ⁽⁵⁾	160.0 6.30	254.0 10.00	163.6 6.44 ⁽⁵⁾	384.3 15.13	N/A	31.8 1.25	24 1 ⁽⁵⁾	-	129.0 5.08	131.1 5.16	79.5 3.13	100.3 3.95	-	30.0 1.18	-	158.8 6.25	46.3 102	
QAAFY22A407S ⁽⁵⁾	4 7/16 in.																				
QAAFY22A408S ⁽⁵⁾	4 1/2 in.																				
QAAFY22A115S ⁽⁵⁾	115 mm	22226	355.6 14.00 ⁽⁵⁾	175.0 6.89	284.2 11.19	177.8 7.00 ⁽⁵⁾	419.1 16.50	N/A	38.1 1.50	27 1 1/8 ⁽⁵⁾	-	169.9 6.69	172.0 6.77	94.5 3.72	139.7 5.50	-	19.1 0.75	-	189.0 7.44	52.2 115	
QAAFY26A125S ⁽⁵⁾	125 mm																				
QAAFY26A415S ⁽⁵⁾	4 15/16 in.																				
QAAFY26A500S ⁽⁵⁾	5 in.																				
QAAFY26A130S ⁽⁵⁾	130 mm																				

⁽¹⁾ Bearing part numbers use QA to designate single-collar units (use S_A and R_A dimensions) and QAA to designate double-collar units (use S_{AA} and R_{AA} dimensions).

⁽²⁾ Pilot tolerance: +0/-0.05 mm (+0/-0.002 in.).

⁽³⁾ Add (p) to the end of the housing designation in the part number to order with pilot using G dimension.

⁽⁴⁾ Piloted flange blocks will be quoted (price and delivery) upon request. For optional spigot on flange side, insert the letter P as seen in the following example: QMFP**J***S.

⁽⁵⁾ Six-bolt housing.

⁽⁶⁾ Three-bolt housing.

QAMC AND QAAMC CARTRIDGE BLOCKS

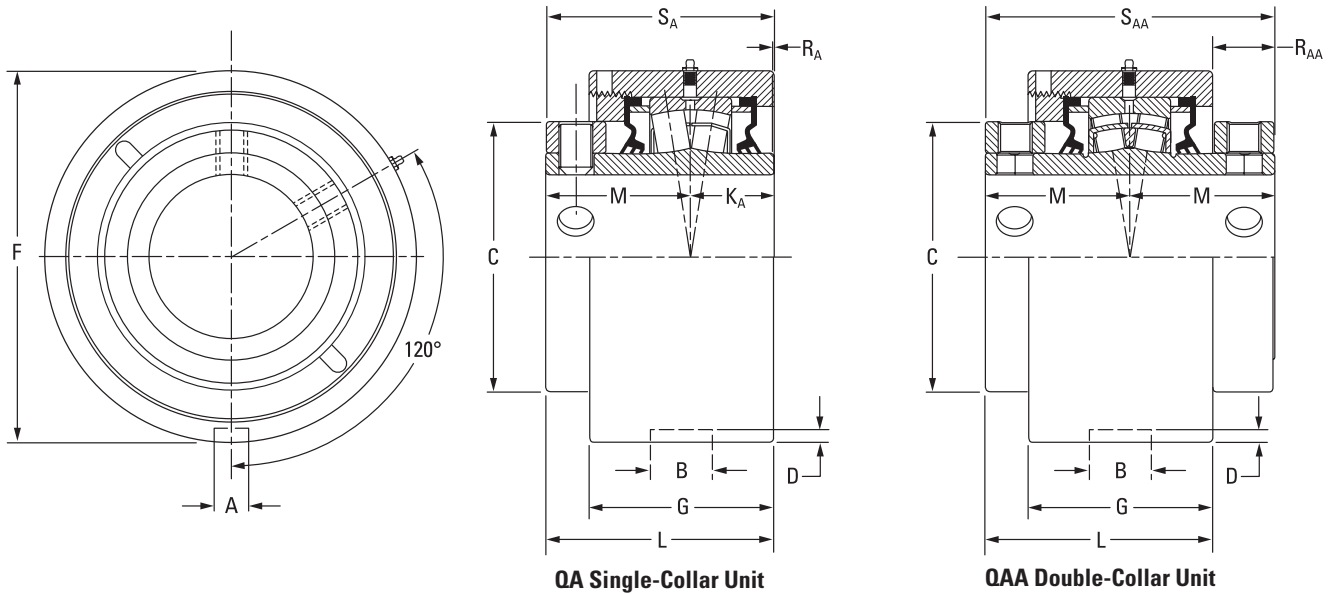

Bearing Part No. ⁽¹⁾	Shaft Dia.	Bearing No.	A	B	C	D	F	G	K _A	L _{FIX}	L _{EXP}	M	R _A	R _{AA}	S _A	S _{AA}	Wt.
			mm in.	mm in.	mm in.	mm in.	mm in.	mm in.	mm in.	mm in.	mm in.	mm in.	mm in.	mm in.	mm in.	mm in.	mm in.
QAMC10A115S QAAMC10A115S	1 15/16 in.	22210	13.5 0.53	23.1 0.91	73.2 2.88	4.8 0.19	104.78 (+0/-0.05) 4.125 (+0/-0.002)	62.2 2.45	25.4 1.00	79.2 3.12	81.3 3.20	47.5 1.87	6.1 0.24	16.8 0.66	72.9 2.87	95.3 3.75	3.6 8
QAMC10A200S QAAMC10A200S	2 in.																
QAMC10A050S QAAMC10A050S	50 mm																
QAMC11A203S QAAMC11A203S	2 3/16 in.	22211	13.5 0.53	23.1 0.91	82.6 3.25	4.8 0.19	115.09 (+0/-0.05) 4.531 (+0/-0.002)	65.5 2.58	28.7 1.13	83.8 3.30	85.9 3.38	50.8 2.00	4.1 0.16	18.0 0.71	79.5 3.13	101.6 4.00	4.5 10
QAMC11A204S QAAMC11A204S	2 1/4 in.																
QAMC11A055S QAAMC11A055S	55 mm																
QAMC13A060S QAAMC13A060S	60 mm	22213	13.5 0.53	23.1 0.91	96.8 3.81	3.6 0.14	127.00 (+0/-0.05) 5.000 (+0/-0.002)	69.3 2.73	31.5 1.24	85.9 3.38	87.9 3.46	54.6 2.15	0.0 0.00	14.0 0.55	86.1 3.39	109.2 4.30	5.4 12
QAMC13A207S QAAMC13A207S	2 7/16 in.																
QAMC13A208S QAAMC13A208S	2 1/2 in.																
QAMC13A065S QAAMC13A065S	65 mm	22215	15.0 0.59	26.2 1.03	109.0 4.29	6.4 0.25	149.225 (+0/-0.05) 5.875 (+0/-0.002)	79.8 3.14	31.8 1.25	100.6 3.96	102.6 4.04	60.2 2.37	8.1 0.32	19.8 0.78	91.9 3.62	120.4 4.74	8.2 18
QAMC15A211S QAAMC15A211S	2 11/16 in.																
QAMC15A212S QAAMC15A212S	2 3/4 in.																
QAMC15A070S QAAMC15A070S	70 mm																
QAMC15A215S QAAMC15A215S	2 15/16 in.																
QAMC15A300S QAAMC15A300S	3 in.																
QAMC15A075S QAAMC15A075S	75 mm																

⁽¹⁾Bearing part numbers use QA to designate single-collar units (use S_A and R_A dimensions) and QAA to designate double-collar units (use S_{AA} and R_{AA} dimensions).

Continued on next page.

SPHERICAL ROLLER BEARING SOLID-BLOCK HOUSED UNITS

CL SERIES • QAMC AND QAAMC CARTRIDGE BLOCKS

QAMC AND QAAMC CARTRIDGE BLOCKS – continued

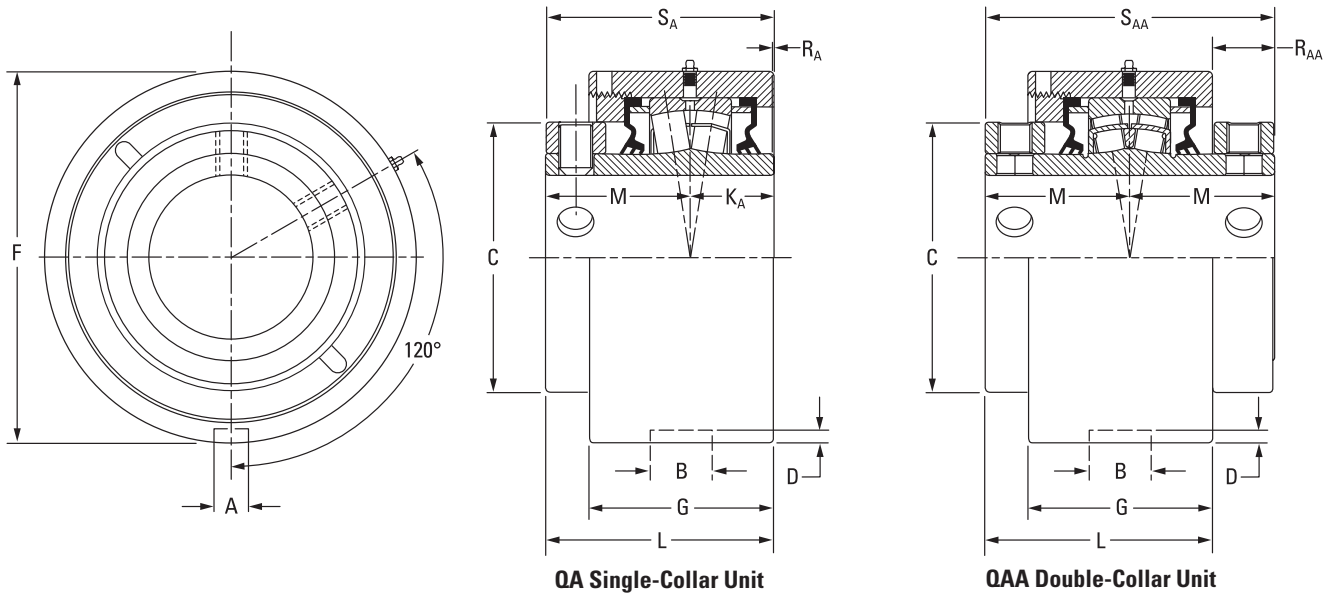

Continued from previous page.

Bearing Part No. ⁽¹⁾	Shaft Dia.	Bearing No.	A	B	C	D	F	G	K _A	L _{FIX}	L _{EXP}	M	R _A	R _{AA}	S _A	S _{AA}	Wt.																
	mm in.		mm in.	mm in.	mm in.	mm in.	mm in.	mm in.	mm in.	mm in.	mm in.	mm in.	mm in.	mm in.	mm in.	mm in.	kg lbs.																
QAMC18A303S QAAMC18A303S	3 3/16 in.	22218	15.0 0.59	26.9 1.06	130.3 5.13	5.8 0.23	171.45 (+0/-0.05) 6.750 (+0/-0.002)	87.6 3.45	36.6 1.44	110.2 4.34	112.3 4.42	65.8 2.59	7.4 0.29	21.3 0.84	102.4 4.03	131.6 5.18	11.8 26																
QAMC18A304S QAAMC18A304S	3 1/4 in.																																
QAMC18A080S QAAMC18A080S	80 mm																																
QAMC18A085S QAAMC18A085S	85 mm																																
QAMC18A307S QAAMC18A307S	3 7/16 in.																																
QAMC18A308S QAAMC18A308S	3 1/2 in.																																
QAMC18A090S QAAMC18A090S	90 mm																																
QAMC20A315S QAAMC20A315S	3 15/16 in.																	22220	19.8 0.78	32.5 1.28	152.4 6.00	7.9 0.31	206.375 (+0/-0.05) 8.125 (+0/-0.002)	105.2 4.14	41.4 1.63	128.3 5.05	130.3 5.13	75.4 2.97	11.4 0.45	22.6 0.89	116.6 4.59	150.9 5.94	14.5 32
QAMC20A400S QAAMC20A400S	4 in.																																
QAMC20A100S QAAMC20A100S	100 mm																																
QAAMC22A110S	110 mm	22222	19.8 0.78	38.1 1.50	160.0 6.30	7.9 0.31	222.25 (+0/-0.08) 8.75 (+0/-0.003)	108.5 4.27	-	133.6 5.26	135.6 5.34	79.5 3.13	-	25.1 0.99	-	158.8 6.25	18.1 40																
QAAMC22A407S	4 7/16 in.																																
QAAMC22A408S	4 1/2 in.																																
QAAMC22A115	115 mm	22226	19.8 0.78	38.1 1.50	175.0 6.89	7.9 0.31	265.13 (+0/-0.08) 10.438 (+0/-0.003)	141.7 5.58	-	165.4 6.51	167.4 6.59	94.5 3.72	-	23.6 0.93	-	189.0 7.44	18.1 40																
QAAMC26A125S	125 mm																																
QAAMC26A415S	4 15/16 in.																																
QAAMC26A500S	5 in.																																
QAAMC26A130S	130 mm																																

⁽¹⁾Bearing part numbers use QA to designate single-collar units (use S_A and R_A dimensions) and QAA to designate double-collar units (use S_{AA} and R_{AA} dimensions).

QATU AND QAATU TAKE-UP BLOCKS

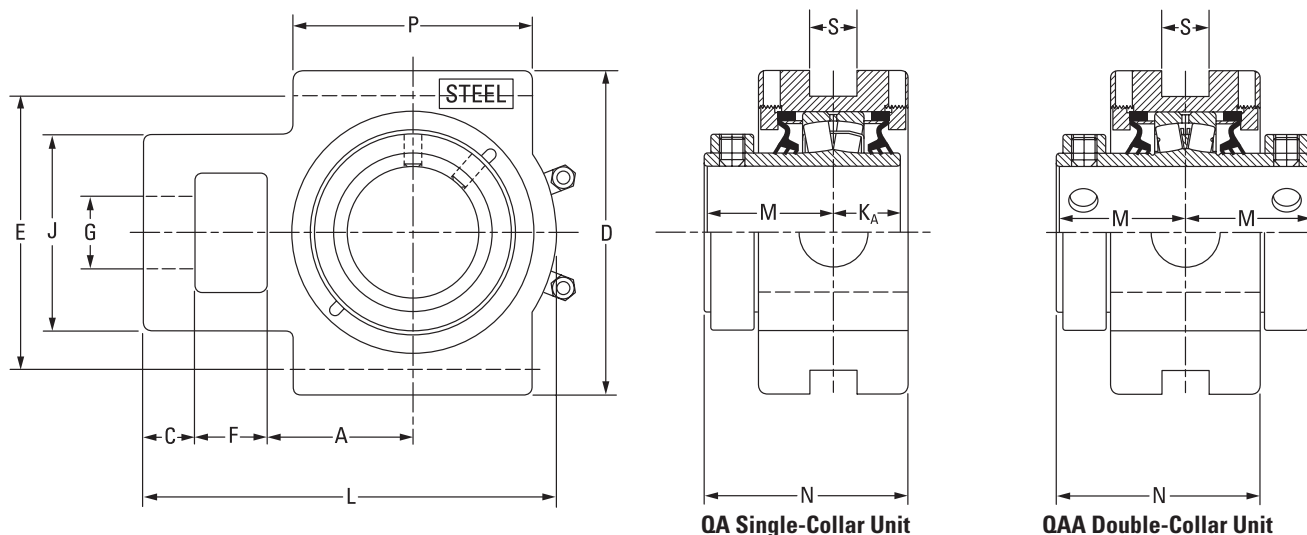

Bearing Part No. ⁽¹⁾	Shaft Dia.	Bearing No.	A	C	D	E	F	G	J	K _A	L	M	N	P	S	Wt.
	mm in.		mm in.	mm in.	mm in.	mm in.	mm in.	mm in.	mm in.	mm in.	mm in.	mm in.	mm in.	mm in.	mm in.	kg lbs.
QATU10A115S QAATU10A115S	1 15/16 in.	22210	54.1 2.13	19.1 0.75	120.7 4.75	101.6 4.00	26.9 1.06	26.9 1.06	73.2 2.88	25.4 1.00	153.4 6.04	47.5 1.87	75.7 2.98	88.9 3.50	17.5 0.69	7.7 17
QATU10A200S QAATU10A200S	2 in.															
QATU10A050S QAATU10A050S	50 mm															
QATU11A203S QAATU11A203S	2 3/16 in.	22211	60.5 2.38	19.1 0.75	133.4 5.25	114.3 4.50	28.7 1.13	30.2 1.19	88.9 3.50	28.7 1.13	167.9 6.61	50.8 2.00	81.8 3.22	95.3 3.75	20.6 0.81	9.5 21
QATU11A204S QAATU11A204S	2 1/4 in.															
QATU11A055S QAATU11A055S	55 mm															
QATU13A060S QAATU13A060S	60 mm	22213	69.9 2.75	22.4 0.88	149.4 5.88	130.3 5.13	33.3 1.31	33.3 1.31	95.3 3.75	31.5 1.24	193.8 7.63	54.6 2.15	91.2 3.59	120.7 4.75	26.9 1.06	12.2 27
QATU13A207S QAATU13A207S	2 7/16 in.															
QATU13A208S QAATU13A208S	2 1/2 in.															
QATU13A065S QAATU13A065S	65 mm	22215	76.2 3.00	25.4 1.00	171.5 6.75	150.9 5.94	39.6 1.56	39.6 1.56	108.0 4.25	31.8 1.25	219.7 8.65	60.2 2.37	97.0 3.82	120.7 4.75	46.0 1.81	15.9 35
QATU15A211S QAATU15A211S	2 11/16 in.															
QATU15A212S QAATU15A212S	2 3/4 in.															
QATU15A070S QAATU15A070S	70 mm															
QATU15A215S QAATU15A215S	2 15/16 in.															
QATU15A300S QAATU15A300S	3 in.															
QATU15A075S QAATU15A075S	75 mm															

⁽¹⁾Bearing part numbers use QA to designate single-collar units and QAA to designate double-collar units.
NOTE: Please refer to page C-169 for take-up frames.

Continued on next page.

SPHERICAL ROLLER BEARING SOLID-BLOCK HOUSED UNITS

CL SERIES • QATU AND QAATU TAKE-UP BLOCKS

QATU AND QAATU TAKE-UP BLOCKS – continued

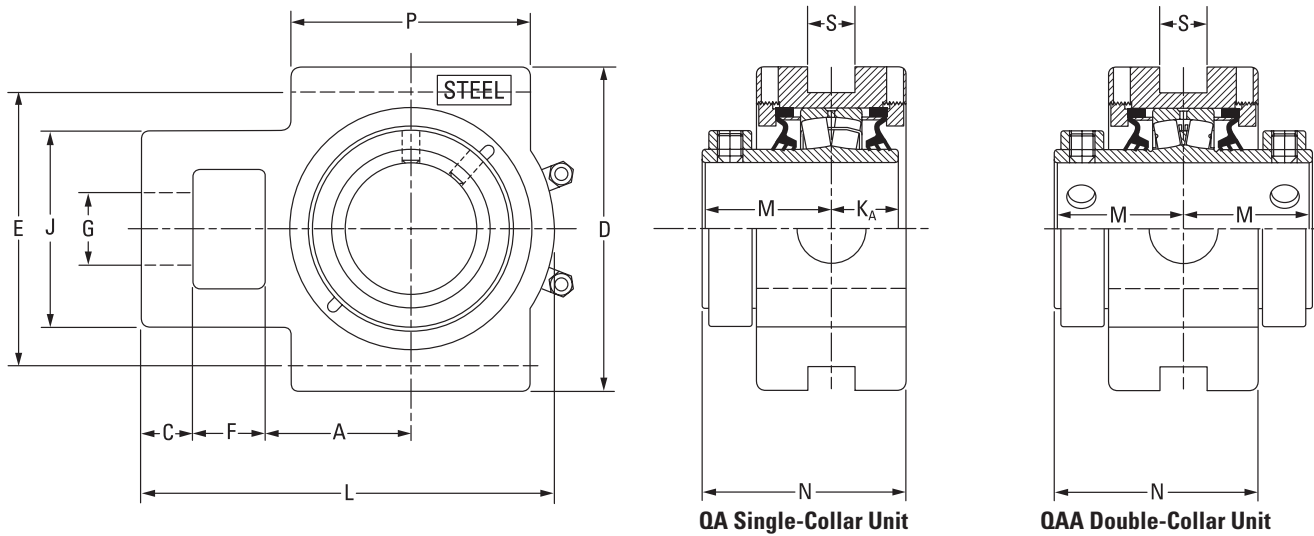

Continued from previous page.

Bearing Part No. ⁽¹⁾	Shaft Dia.	Bearing No.	A	C	D	E	F	G	J	K _A	L	M	N	P	S	Wt.
	mm in.		mm in.	mm in.	mm in.	mm in.	mm in.	mm in.	mm in.	mm in.	mm in.	mm in.	mm in.	mm in.	mm in.	kg lbs.
QATU18A303S QAATU18A303S	3 3/16 in.	22218	92.2 3.63	25.4 1.00	193.8 7.63	173.0 6.81	46.0 1.81	47.8 1.88	124.0 4.88	36.6 1.44	257.0 10.12	65.8 2.59	107.2 4.22	158.8 6.25	46.0 1.81	20.0 44
QATU18A304S QAATU18A304S	3 1/4 in.															
QATU18A080S QAATU18A080S	80 mm															
QATU18A085S QAATU18A085S	85 mm															
QATU18A307S QAATU18A307S	3 7/16 in.															
QATU18A308S QAATU18A308S	3 1/2 in.															
QATU18A090S QAATU18A090S	90 mm															
QATU20A315S QAATU20A315S	3 15/16 in.															
QATU20A400S QAATU20A400S	4 in.															
QATU20A100S QAATU20A100S	100 mm															
QAATU22A110S	110 mm	22222	128.5 5.06	38.1 1.50	263.7 10.38	241.3 9.50	54.1 2.13	54.1 2.13	162.1 6.38	-	341.4 13.44	79.5 3.13	143.8 5.66	199.9 7.87	52.3 2.06	36.4 80
QAATU22A407S	4 7/16 in.															
QAATU22A408S	4 1/2 in.															
QAATU22A115S	115 mm	22226	134.9 5.31	63.5 2.50	285.8 11.25	260.4 10.25	63.5 2.50	60.5 2.38	177.8 7.00	-	396.7 15.62	94.5 3.72	150.9 5.94	228.6 9.00	52.3 2.06	60.8 134
QAATU26A125S	125 mm															
QAATU26A415S	4 15/16 in.															
QAATU26A500S	5 in.															
QAATU26A130S	130 mm															

⁽¹⁾Bearing part numbers use QA to designate single-collar units and QAA to designate double-collar units.

NOTE: Please refer to page C-169 for take-up frames.

QAMH AND QAAMH HANGER BLOCKS

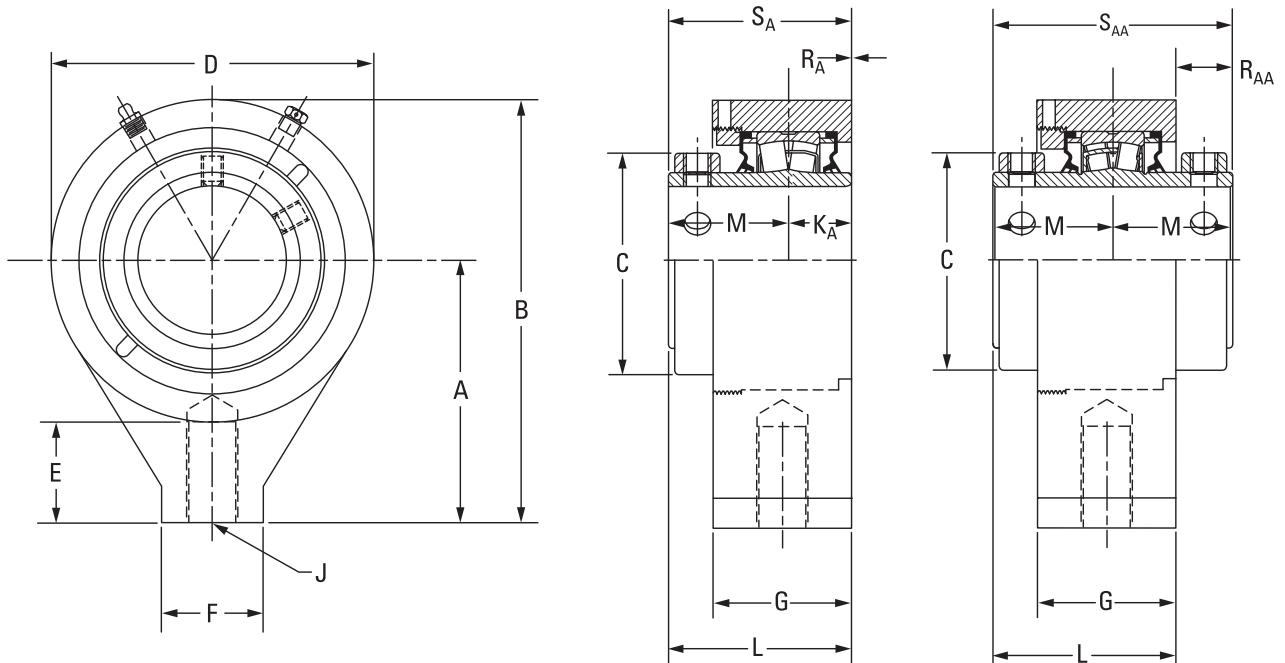

Bearing Part No.	Shaft Dia.	Bearing No.	A	B	C	D	E	F	G	J	K _A	L	M	R _A	R _{AA}	S _A	S _{AA}	Wt.
	mm in.		mm in.	mm in.	mm in.	mm in.	mm in.	mm in.	mm in.	in.	mm in.	mm in.	mm in.	mm in.	mm in.	mm in.	mm in.	kg lbs.
QAMH15A211S QAAMH15A211S	2 1/16 in.	22215	131.8 5.19	212.9 8.38	109.0 4.29	162.1 6.38	50.8 2.00	50.8 2.00	69.9 2.75	1 - 8UNC	31.8 1.25	91.9 3.62	60.2 2.37	0.0 0.00	28.4 1.12	91.9 3.62	120.7 4.75	10.0 22
QAMH15A212S QAAMH15A212S	2 3/4 in.																	
QAMH15A070S QAAMH15A070S	70 mm																	
QAMH15A215S QAAMH15A215S	2 15/16 in.																	
QAMH15A300S QAAMH15A300S	3 in.																	
QAMH15A075S QAAMH15A075S	75 mm																	
QAMH18A303S QAAMH18A303S	3 3/16 in.																	
QAMH18A304S QAAMH18A304S	3 1/4 in.																	
QAMH18A080S QAAMH18A080S	80 mm																	
QAMH18A085S QAAMH18A085S	85 mm																	
QAMH18A307S QAAMH18A307S	3 7/16 in.																	
QAMH18A308S QAAMH18A308S	3 1/2 in.																	
QAMH18A090S QAAMH18A090S	90 mm																	

EC SERIES

The reduced eccentric offset of our EC series locking collar results in a secure shaft lock that is designed not to release from a properly prepared shaft. EC series housed units also are suitable for reversing applications.



Fig. C-45. EC series eccentric lock.

YOU HAVE CHOICES

For the EC series, you can select from many seal configurations and housing styles, which are shown on page C-130.

HOUSINGS

- Two-bolt pillow blocks.
- Four-bolt pillow blocks.
- Flange blocks.
- Piloted flange cartridges.
- Take-up blocks.
- Cartridge blocks.
- Hanger blocks.

SEALS

- Labyrinth: DuPont Teflon (T).
- Triple-lip: nitrile rubber (M), urethane (O) and DuPont Viton (N).
- Double-lip: nitrile rubber (B) and DuPont Viton (C).
- Steel and urethane closed-end covers (CS).
- Steel and urethane open-end covers (CJ) with:
 - DuPont Teflon (T).
 - Triple-lip seal (DR).
 - V-ring seal (VR).
- Piloted flange cartridge backing plates (HSY) with:
 - Triple-lip seal (DR).
- Flange block backing plates (UFP).
 - V-ring (VR).

SPHERICAL ROLLER BEARING SOLID-BLOCK HOUSED UNITS

EC SERIES

EC SERIES

	Housing Type	Primary Seals						Secondary Seals and Covers						
		M	N	O	B	C	T	Open-End Cover			Closed-End Cover	HSY Flange Cartridge Backing Plate		UFP Backing Plate
		DR	VR	T	DR	DR	DR							
V-Lock (Timken Exclusive Double Taper Lock)	Pillow Block	•	•	•	•	•	•	•	•	•	•	•		
	Flange Block	•	•	•	•	•	•	•	•	•	•	•		
	Piloted Flange Cartridge	•	•	•	•	•	•	•	•	•	•	•		
	Take-Up Block	•	•	•	•	•	•	•	•	•	•	•		
	Cartridge Block	•	•	•	•	•	•	•	•	•	•	•		
CL Series (Set Screw Lock)	Pillow Block	•	•	•	•	•	•	•	•	•	•	•		
	Flange Block	•	•	•	•	•	•	•	•	•	•	•		•
	Piloted Flange Cartridge	•	•	•	•	•	•	•	•	•	•	•	•	
	Take-Up Block	•	•	•	•	•	•	•	•	•	•	•		
	Cartridge Block	•	•	•	•	•	•	•	•	•	•	•		
	Hangar Block	•	•	•	•	•	•	•	•	•	•	•		
EC Series (Eccentric Lock)	Pillow Block	•	•	•	•	•	•	•	•	•	•	•		
	Flange Block	•	•	•	•	•	•	•	•	•	•	•		•
	Piloted Flange Cartridge	•	•	•	•	•	•	•	•	•	•	•	•	
	Take-Up Block	•	•	•	•	•	•	•	•	•	•	•		
	Cartridge Block	•	•	•	•	•	•	•	•	•	•	•		
	Hangar Block	•	•	•	•	•	•	•	•	•	•	•		
TA Series (Tapered Adapter Lock)	Pillow Block	•	•	•	•	•	•	•	•	•	•	•		
	Flange Block	•	•	•	•	•	•	•	•	•	•	•		
	Piloted Flange Cartridge	•	•	•	•	•	•	•	•	•	•	•		
	Cartridge Block	•	•	•	•	•	•	•	•	•	•	•		
DV Series (Tapered Adapter Lock)	Pillow Block	•	•	•	•	•	•	•	•	•	•	•		
	Flange Block	•	•	•	•	•	•	•	•	•	•	•		
	Piloted Flange Cartridge	•	•	•	•	•	•	•	•	•	•	•		

QMP TWO-BOLT PILLOW BLOCKS

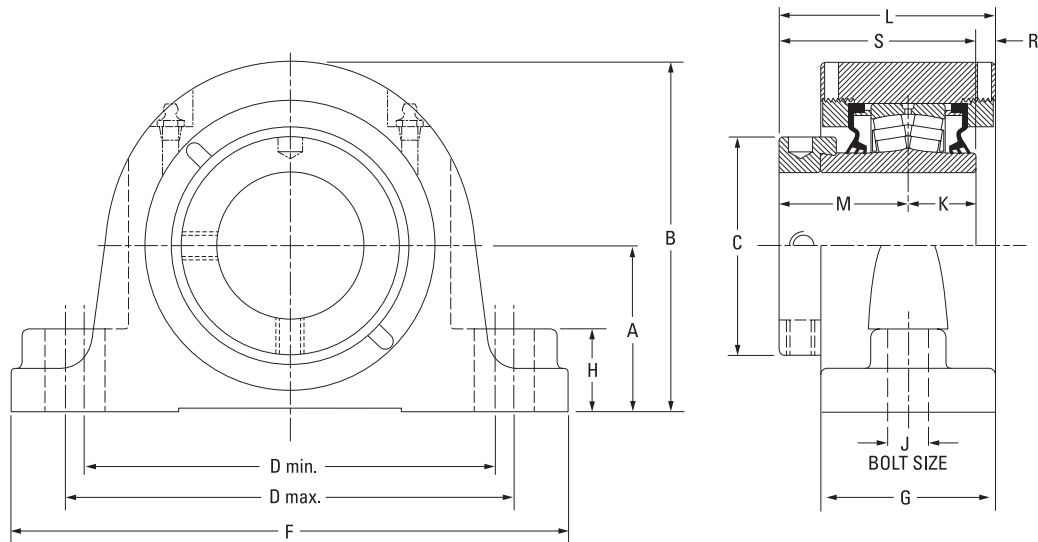

Bearing Part No.	Shaft Dia.	Bearing No.	A	B	C	D min.	D max.	F	G	H	J	K	L	M	R	S	Wt.	
	mm in.		mm in.	mm in.	mm in.	mm in.	mm in.	mm in.	mm in.	mm in.	mm in.	mm in.	mm in.	mm in.	mm in.	mm in.	kg lbs.	
QMP08J035S	35 mm	22208	47.8	94.7	60.5	119.1	152.4	174.8	57.2	25.4	12	25.4	73.2	44.5	3.3	69.9	4.1	
QMP08J107S	1 7/16 in.		1.88	3.73	2.38	4.69	6.00	6.88	2.25	1.00	1/2	1.00	2.88	1.75	0.13	2.75	9	
QMP08J108S	1 1/2 in.	22208	54.1	101.1	60.5	119.1	165.1	200.2	57.2	25.4	12	25.4	73.2	44.5	3.3	69.9	4.1	
			2.13	3.98	2.38	4.69	6.50	7.88	2.25	1.00	1/2	1.00	2.88	1.75	0.13	2.75	9	
QMP09J111S	1 11/16 in.	22209	54.1	104.9	66.5	144.8	165.1	200.2	60.2	31.8	12	25.4	77.7	47.8	4.8	73.2	4.5	
			2.13	4.13	2.62	5.70	6.50	7.88	2.37	1.25	1/2	1.00	3.06	1.88	0.19	2.88	10	
QMP09J040S	40 mm	22209	57.2	108.0	66.5	158.8	180.8	225.6	62.0	31.8	16	25.4	78.7	47.8	5.8	73.2	4.5	
QMP09J112S	1 3/4 in.		2.25	4.25	2.62	6.25	7.12	8.88	2.44	1.25	5/8	1.00	3.10	1.88	0.23	2.88	10	
QMP09J045S	45 mm																	
QMP10J115S	1 15/16 in.	22210	57.2	122.2	71.4	152.4	181.1	225.6	62.0	31.8	16	25.4	79.0	47.5	6.1	72.9	5.9	
QMP10J200S	2 in.		2.25	4.81	2.81	6.00	7.13	8.88	2.44	1.25	5/8	1.00	3.11	1.87	0.24	2.87	13	
QMP10J050S	50 mm																	
QMP11J203S	2 3/16 in.	22211	63.5	133.4	75.9	165.1	200.2	244.6	66.8	31.8	16	28.7	84.1	50.8	4.8	79.5	7.7	
QMP11J204S	2 1/4 in.		2.50	5.25	2.99	6.50	7.88	9.63	2.63	1.25	5/8	1.13	3.31	2.00	0.19	3.13	17	
QMP11J055S	55 mm																	
QMP13J060S	60 mm	22213	69.9	147.3	91.9	174.8	219.2	260.4	73.7	35.1	16	31.5	91.2	54.1	5.3	85.6	10.0	
QMP13J207S	2 7/16 in.		2.75	5.80	3.62	6.88	8.63	10.25	2.90	1.38	5/8	1.24	3.59	2.13	0.21	3.37	22	
QMP13J208S	2 1/2 in.																	
QMP13J065S	65 mm	22215	79.5	164.3	101.9	200.2	244.6	295.4	76.2	35.1	20	31.8	98.3	60.2	6.4	91.9	12.7	
QMP15J211S	2 11/16 in.																	
QMP15J212S	2 3/4 in.																	
QMP15J070S	70 mm	22215	79.5	164.3	101.9	200.2	244.6	295.4	76.2	35.1	20	31.8	98.3	60.2	6.4	91.9	12.7	
QMP15J215S	2 15/16 in.		3.13	6.47	4.01	7.88	9.63	11.63	3.00	1.38	3/4	1.25	3.87	2.37	0.25	3.62	28	
QMP15J300S	3 in.																	
QMP15J075S	75 mm	22218	95.3	195.3	120.9	238.3	285.8	342.9	86.6	47.8	24	36.6	109.2	65.8	7.1	102.4	20.4	
QMP18J303S	3 3/16 in.																	
QMP18J304S	3 1/4 in.																	
QMP18J080S	80 mm	22218	95.3	195.3	120.9	238.3	285.8	342.9	86.6	47.8	24	36.6	109.2	65.8	7.1	102.4	20.4	
QMP18J085S	85 mm		3.75	7.69	4.76	9.38	11.25	13.50	3.41	1.88	7/8	1.44	4.30	2.59	0.28	4.03	45	
QMP18J307S	3 7/16 in.																	
QMP18J308S	3 1/2 in.	22220	104.9	209.8	152.4	255.0	320.0	362.0	94.7	50.8	24	41.4	122.9	75.2	6.1	116.6	26.8	
QMP18J090S	90 mm																	
QMP20J311S	3 11/16 in.																	
QMP20J312S	3 3/4 in.	22220	104.9	209.8	152.4	255.0	320.0	362.0	94.7	50.8	24	41.4	122.9	75.2	6.1	116.6	26.8	
QMP20J315S	3 15/16 in.		4.13	8.26	6.00	10.04	12.60	14.25	3.73	2.00	1	1.63	4.84	2.96	0.24	4.59	59	
QMP20J400S	4 in.																	
QMP20J100S	100 mm																	

SPHERICAL ROLLER BEARING SOLID-BLOCK HOUSED UNITS

EC SERIES • QMPL TWO-BOLT PILLOW BLOCKS

QMPL TWO-BOLT PILLOW BLOCKS

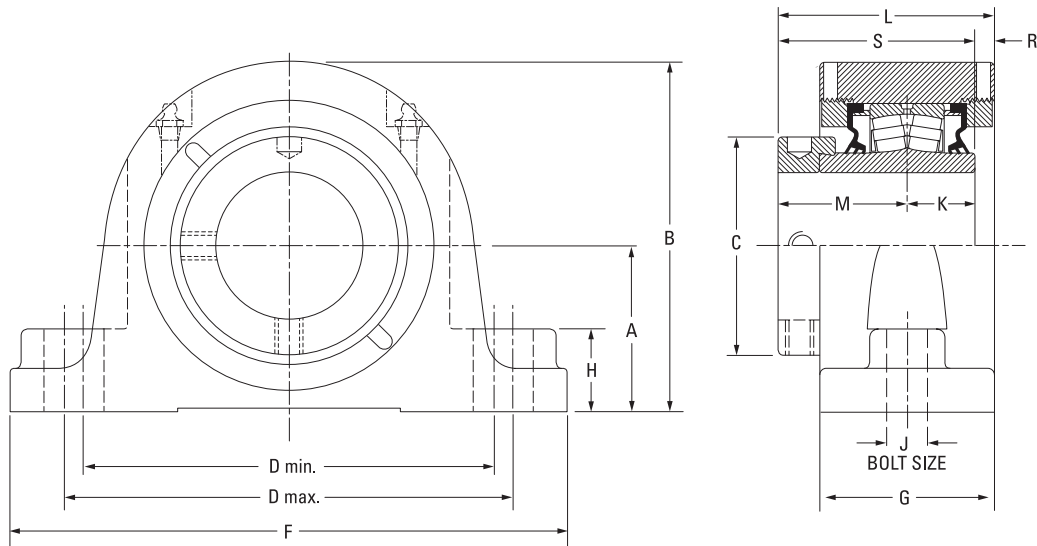

Bearing Part No.	Shaft Dia.	Bearing No.	A	B	C	D min.	D max.	F	G	H	J	K	L	M	R	S	Wt.
	mm in.		mm in.	mm in.	mm in.	mm in.	mm in.	mm in.	mm in.	mm in.	mm in.	mm in.	mm in.	mm in.	mm in.	mm in.	kg lbs.
QMPL08J035S	35 mm	22208	47.8	94.7	60.5	119.1	152.4	174.8	57.2	25.4	12	25.4	73.2	44.5	3.3	69.9	4.1
QMPL08J107S	1 7/16 in.		1.88	3.73	2.38	4.69	6.00	6.88	2.25	1.00	1/2	1.00	2.88	1.75	0.13	2.75	9
QMPL08J108S	1 1/2 in.																
QMPL09J040S	40 mm	22209	54.1	104.9	66.5	133.4	146.1	181.1	60.2	31.8	12	25.4	77.7	47.8	4.8	73.2	4.5
QMPL09J111S	1 11/16 in.		2.13	4.13	2.62	5.25	5.75	7.13	2.37	1.25	1/2	1.00	3.06	1.88	0.19	2.88	10
QMPL09J112S	1 3/4 in.																
QMPL09J045S	45 mm	22210	57.2	122.2	71.4	150.6	161.5	212.9	62.0	31.8	16	25.4	79.0	47.5	6.1	72.9	5.9
QMPL10J115S	1 15/16 in.		2.25	4.81	2.81	5.93	6.36	8.38	2.44	1.25	5/8	1.00	3.11	1.87	0.24	2.87	13
QMPL10J200S	2 in.																
QMPL10J050S	50 mm	22211	63.5	133.4	75.9	165.1	179.3	225.6	65.5	31.8	16	28.4	83.3	50.8	4.3	79.2	7.7
QMPL11J203S	2 3/16 in.		2.50	5.25	2.99	6.50	7.06	8.88	2.58	1.25	5/8	1.12	3.28	2.00	0.17	3.12	17
QMPL11J204S	2 1/4 in.																
QMPL11J055S	55 mm	22213	69.9	147.3	91.9	173.0	189.0	235.0	73.7	35.1	16	31.5	90.9	54.1	5.3	85.6	10.0
QMPL13J060S	60 mm		2.75	5.80	3.62	6.81	7.44	9.25	2.90	1.38	5/8	1.24	3.58	2.13	0.21	3.37	22
QMPL13J207S	2 7/16 in.																
QMPL13J065S	65 mm	22215	82.6	167.4	101.9	195.6	213.4	265.2	76.2	35.1	20	31.8	98.3	60.2	6.4	91.9	12.7
QMPL15J211S	2 11/16 in.		3.25	6.59	4.01	7.70	8.40	10.44	3.00	1.38	3/4	1.25	3.87	2.37	0.25	3.62	28
QMPL15J212S	2 3/4 in.																
QMPL15J070S	70 mm	22218	95.3	195.3	120.9	235.0	273.1	330.2	86.6	47.8	24	36.6	109.2	65.8	7.1	102.4	20.4
QMPL15J300S	3 in.		3.75	7.69	4.76	9.25	10.75	13.00	3.41	1.88	7/8	1.44	4.30	2.59	0.28	4.03	45
QMPL15J075S	75 mm																
QMPL18J303S	3 3/16 in.	22220	108.0	212.9	152.4	255.0	320.0	362.0	94.7	53.8	24	41.4	122.9	75.2	6.1	116.6	26.8
QMPL18J304S	3 1/4 in.		4.25	8.38	6.00	10.04	12.60	14.25	3.73	2.12	1	1.63	4.84	2.96	0.24	4.59	59
QMPL18J080S	80 mm																
QMPL18J085S	85 mm																
QMPL18J307S	3 7/16 in.																
QMPL18J308S	3 1/2 in.																
QMPL18J090S	90 mm																
QMPL20J311S	3 11/16 in.																
QMPL20J312S	3 3/4 in.																
QMPL20J315S	3 15/16 in.																
QMPL20J400S	4 in.																
QMPL20J100S	100 mm																

QMPF FOUR-BOLT PILLOW BLOCKS

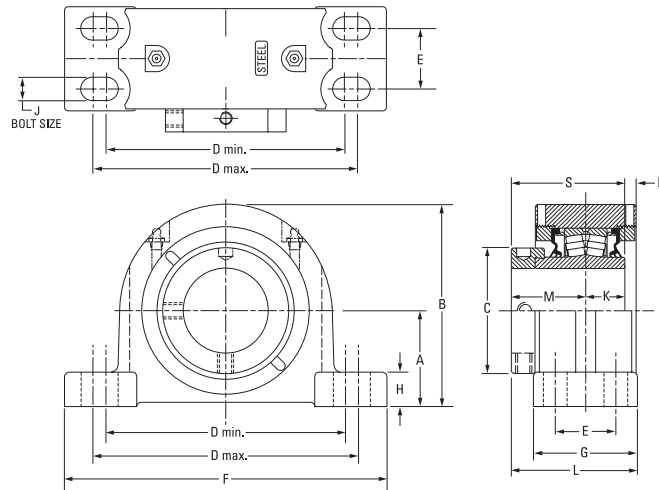

Bearing Part No.	Shaft Dia.	Bearing No.	A	B	C	D min.	D max.	E	F	G	H	J	K	L	M	R	S	Wt.
	mm in.		mm in.	mm in.	mm in.	mm in.	mm in.	mm in.	mm in.	mm in.	mm in.	mm in.	mm in.	mm in.	mm in.	mm in.	mm in.	kg lbs.
QMPF13J060S	60 mm	22213	69.9	147.3	91.9	174.8	193.8	44.5	235.0	76.2	24.9	16	31.5	92.2	54.1	5.3	85.6	9.1
QMPF13J207S	2 7/16 in.		2.75	5.80	3.62	6.88	7.63	1.75	9.25	3.00	0.98	5/8	1.24	3.63	2.13	0.21	3.37	20
QMPF13J208S	2 1/2 in.																	
QMPF13J065S	65 mm	22215	82.6	167.6	101.9	193.0	231.1	47.8	265.2	79.5	32.8	16	31.8	99.8	60.2	6.1	91.9	12.2
QMPF15J211S	2 11/16 in.		3.25	6.60	4.01	7.60	9.10	1.88	10.44	3.13	1.29	5/8	1.25	3.93	2.37	0.24	3.62	27
QMPF15J212S	2 3/4 in.																	
QMPF15J070S	70 mm	22218	95.3	195.3	120.9	225.6	276.4	50.8	312.4	95.3	39.6	20	36.6	113.3	65.8	8.1	102.4	22.2
QMPF15J215S	2 15/16 in.		3.75	7.69	4.76	8.88	10.88	2.00	12.30	3.75	1.56	3/4	1.44	4.46	2.59	0.32	4.03	49
QMPF15J300S	3 in.																	
QMPF15J075S	75 mm	22220	108.0	223.0	152.4	276.4	339.9	57.2	378.0	109.5	35.6	20	41.4	130.3	75.2	9.1	116.6	30.4
QMPF18J303S	3 3/16 in.		4.25	8.78	6.00	10.88	13.38	2.25	14.88	4.31	1.40	3/4	1.63	5.13	2.96	0.36	4.59	67
QMPF18J304S	3 1/4 in.																	
QMPF18J080S	80 mm	22222	120.7	233.4	160.0	301.8	368.3	63.5	409.7	120.7	40.1	20	46.5	154.4	94.0	4.3	140.5	37.2
QMPF18J085S	85 mm		4.75	9.19	6.30	11.88	14.50	2.50	16.13	4.75	1.58	3/4	1.83	6.08	3.70	0.17	5.53	82
QMPF18J307S	3 7/16 in.																	
QMPF18J308S	3 1/2 in.	22226	139.7	279.7	175.0	349.3	403.4	69.9	444.5	128.0	39.1	24	58.7	158.8	94.7	-0.8	153.4	60.8
QMPF18J090S	90 mm		5.50	11.01	6.89	13.75	15.88	2.75	17.5	5.04	1.54	7/8	2.31	6.25	3.73	-0.03	6.04	134
QMPF20J311S	3 11/16 in.																	
QMPF20J312S	3 3/4 in.	23230	169.9	330.2	205.0	441.5	485.9	95.3	558.8	171.5	76.2	24	75.9	201.7	116.1	6.6	192.0	113.4
QMPF20J315S	3 15/16 in.		6.69	13.00	8.07	17.38	19.13	3.75	22.00	6.75	3.00	1	2.99	7.94	4.57	0.26	7.56	250
QMPF20J400S	4 in.																	
QMPF20J100S	100 mm	23234	190.5	390.7	235.0	530.4	600.2	117.5	660.4	190.5	63.5	24	85.1	224.3	129.0	5.6	214.1	170.1
QMPF22J110S	110 mm		7.50	15.38	9.25	20.88	23.63	4.625	26.00	7.50	2.50	1	3.35	8.83	5.08	0.22	8.43	375
QMPF22J407S	4 7/16 in.																	
QMPF22J408S	4 1/2 in.	23230	169.9	330.2	205.0	441.5	485.9	95.3	558.8	171.5	76.2	24	75.9	201.7	116.1	6.6	192.0	113.4
QMPF26J125S	125 mm		6.69	13.00	8.07	17.38	19.13	3.75	22.00	6.75	3.00	1	2.99	7.94	4.57	0.26	7.56	250
QMPF26J415S	4 15/16 in.																	
QMPF26J500S	5 in.	23230	169.9	330.2	205.0	441.5	485.9	95.3	558.8	171.5	76.2	24	75.9	201.7	116.1	6.6	192.0	113.4
QMPF26J130S	130 mm		6.69	13.00	8.07	17.38	19.13	3.75	22.00	6.75	3.00	1	2.99	7.94	4.57	0.26	7.56	250
QMPF30J507S	5 7/16 in.																	
QMPF30J508S	5 1/2 in.	23234	190.5	390.7	235.0	530.4	600.2	117.5	660.4	190.5	63.5	24	85.1	224.3	129.0	5.6	214.1	170.1
QMPF30J140S	140 mm		7.50	15.38	9.25	20.88	23.63	4.625	26.00	7.50	2.50	1	3.35	8.83	5.08	0.22	8.43	375
QMPF30J515S	5 15/16 in.																	
QMPF30J600S	6 in.	23234	190.5	390.7	235.0	530.4	600.2	117.5	660.4	190.5	63.5	24	85.1	224.3	129.0	5.6	214.1	170.1
QMPF30J150S	150 mm		7.50	15.38	9.25	20.88	23.63	4.625	26.00	7.50	2.50	1	3.35	8.83	5.08	0.22	8.43	375
QMPF34J607S	6 7/16 in.																	
QMPF34J608S	6 1/2 in.	23234	190.5	390.7	235.0	530.4	600.2	117.5	660.4	190.5	63.5	24	85.1	224.3	129.0	5.6	214.1	170.1
QMPF34J170S	170 mm		7.50	15.38	9.25	20.88	23.63	4.625	26.00	7.50	2.50	1	3.35	8.83	5.08	0.22	8.43	375
QMPF34J615S	6 15/16 in.																	
QMPF34J700S	7 in.	23234	190.5	390.7	235.0	530.4	600.2	117.5	660.4	190.5	63.5	24	85.1	224.3	129.0	5.6	214.1	170.1
QMPF34J180S	180 mm		7.50	15.38	9.25	20.88	23.63	4.625	26.00	7.50	2.50	1	3.35	8.83	5.08	0.22	8.43	375

SPHERICAL ROLLER BEARING SOLID-BLOCK HOUSED UNITS

EC SERIES • QMPR FOUR-BOLT PILLOW BLOCKS

QMPR FOUR-BOLT PILLOW BLOCKS

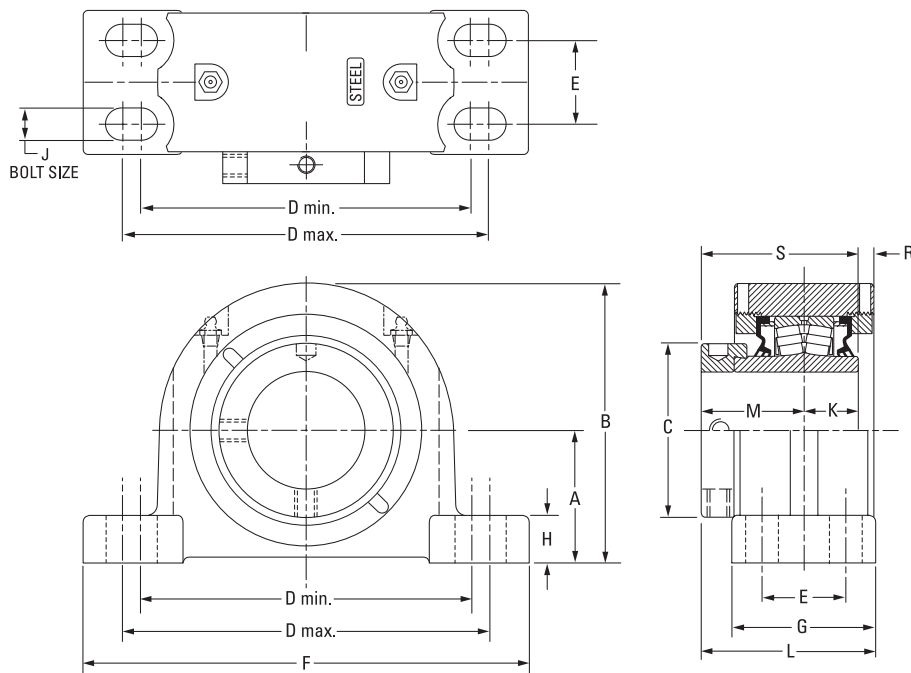

Bearing Part No.	Shaft Dia.	Bearing No.	A	B	C	D min.	D max.	E	F	G	H	J	K	L	M	R	S	Wt.	
	mm in.		mm in.	mm in.	mm in.	mm in.	mm in.	mm in.	mm in.	mm in.	mm in.	mm in.	mm in.	mm in.	mm in.	mm in.	mm in.	kg lbs.	
QMPR13J060S	60 mm	22213	69.9	147.3	91.9	181.1	222.3	47.8	260.4	82.6	24.9	16	31.5	95.5	54.1	5.3	85.6	9.1	
QMPR13J207S	2 7/16 in.		2.75	5.80	3.62	7.13	8.75	1.88	10.25	3.25	0.98	5/8	1.24	3.76	2.13	0.21	3.37	20	
QMPR13J208S	2 1/2 in.																		
QMPR13J065S	65 mm																		
QMPR15J211S	2 11/16 in.	22215	79.5	164.3	101.9	203.2	243.8	54.1	275.1	85.9	29.5	16	31.8	103.1	60.2	6.1	91.9	12.2	
QMPR15J212S	2 3/4 in.		3.13	6.47	4.01	8.00	9.60	2.13	10.83	3.38	1.16	5/8	1.25	4.06	2.37	0.24	3.62	27	
QMPR15J070S	70 mm																		
QMPR15J215S	2 15/16 in.																		
QMPR15J300S	3 in.																		
QMPR15J075S	75 mm																		
QMPR18J303S	3 3/16 in.	22218	95.3	195.3	120.9	235.0	285.8	60.5	346.2	95.3	39.6	20	36.6	113.3	65.8	8.1	102.4	22.2	
QMPR18J304S	3 1/4 in.		3.75	7.69	4.76	9.25	11.25	2.38	13.63	3.75	1.56	3/4	1.44	4.46	2.59	0.32	4.03	49	
QMPR18J080S	80 mm																		
QMPR18J085S	85 mm																		
QMPR18J307S	3 7/16 in.																		
QMPR18J308S	3 1/2 in.																		
QMPR18J090S	90 mm																		

QMPH/QMPG FOUR-BOLT PILLOW BLOCKS

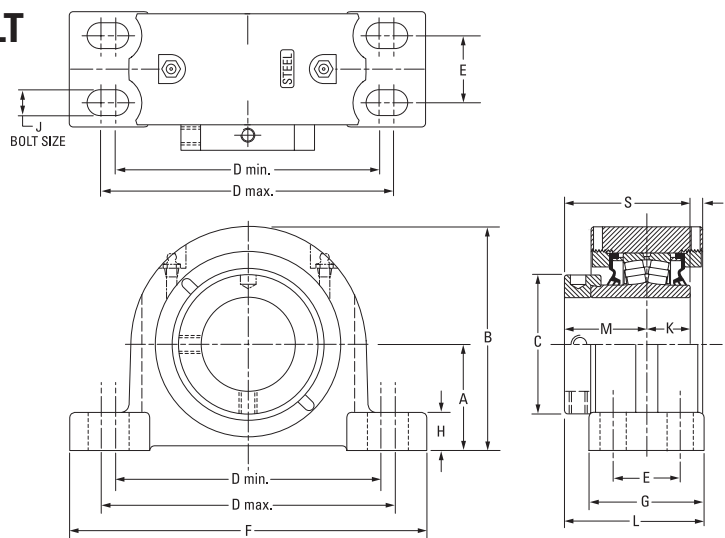

QMPH SAF STYLE FOUR-BOLT PILLOW BLOCK DIMENSIONS

Bearing Part No.	Shaft Dia.	Bearing No.	A	B	C	D min.	D max.	E	F	G	H	J	K	L	M	R	S	Wt.	
	mm in.		mm in.	mm in.	mm in.	mm in.	mm in.	mm in.	mm in.	mm in.	mm in.	mm in.	mm in.	mm in.	mm in.	mm in.	mm in.	kg lbs.	
QMPH26J125S	125 mm	22226	152.4 6.00	284 11.18	175 6.89	406.4 16.00	435.1 17.13	85.9 3.38	500.4 19.70	128 5.04	51.8 2.04	24 1	58.7 2.31	158.5 6.24	94.5 3.72	-0.7 -0.028	153.4 6.04	60.8 134	
QMPH26J415S	4 15/16 in.																		
QMPH26J500S	5 in.																		
QMPH26J130S	130 mm	23230	169.9 6.688	330.7 13.02	205.0 8.07	441.5 17.38	485.9 19.13	95.3 3.75	558.8 22.00	171.5 6.75	76.2 3.00	24 1	75.9 2.99	199.1 7.84	116.1 4.57	5.1 0.20	192.0 7.56	113.4 250	
QMPH30J507S	5 7/16 in.																		
QMPH30J508S	5 1/2 in.																		
QMPH30J140S	140 mm	23230	179.4 7.063	339.9 13.38	205.0 8.07	492.3 19.38	549.4 21.63	108.0 4.25	628.7 24.75	171.5 6.75	85.9 3.38	24 1	75.9 2.99	201.7 7.94	116.1 4.57	6.6 0.26	192.0 7.56	113.4 250	
QMPH30J515S	5 15/16 in.																		
QMPH30J600S	6 in.																		
QMPH30J150S	150 mm	23234	190.5 7.50	390.7 15.38	235.0 9.25	530.4 20.88	600.2 23.63	117.5 4.625	711.2 28.00	190.5 7.50	63.5 2.50	24 1	85.1 3.35	224.3 8.83	129.0 5.08	5.6 0.22	214.1 8.43	170.1 375	
QMPH34J607S	6 7/16 in.																		
QMPH34J608S	6 1/2 in.																		
QMPH34J170S	170 mm	23234	200.0 7.875	400.1 15.75	235.0 9.25	549.4 21.63	619.3 24.38	114.3 4.50	711.2 28.00	190.5 7.50	73.2 2.88	30 1 1/4	85.1 3.35	224.3 8.83	129.0 5.08	5.6 0.22	214.1 8.43	170.1 375	
QMPH34J615S	6 15/16 in.																		
QMPH34J700S	7 in.																		
QMPH34J180S	180 mm																		

QMPG SN STYLE FOUR-BOLT PILLOW BLOCK DIMENSIONS

Bearing Part No.	Shaft Dia.	Bearing No.	A	B	C	D min.	D max.	E	F	G	H	J	K	L	M	R	S	Wt.	
	mm in.		mm in.	mm in.	mm in.	mm in.	mm in.	mm in.	mm in.	mm in.	mm in.	mm in.	mm in.	mm in.	mm in.	mm in.	mm in.	kg lbs.	
QMPG26J125S	125 mm	22226	150.0 5.906	281.4 11.08	175.0 6.89	384.3 15.13	447.8 17.63	80.0 3.15	500.1 19.69	128 5.04	49.3 1.94	24 1	58.7 2.31	158.5 6.24	94.5 3.72	-6.9 -0.27	153.4 6.04	60.8 134	
QMPG26J415S	4 15/16 in.																		
QMPG26J500S	5 in.																		
QMPG26J130S	130 mm	23230	170.0 6.693	332.2 13.08	205.0 8.07	438.2 17.25	482.6 19.00	89.9 3.54	547.6 21.65	171.5 6.75	76.2 3.00	24 1	75.9 2.99	198.6 7.82	116.1 4.57	9.7 0.38	192.0 7.56	113.4 250	
QMPG30J507S	5 7/16 in.																		
QMPG30J508S	5 1/2 in.																		
QMPG30J140S	140 mm	23234	190.5 7.50	390.7 15.38	235.0 9.25	530.4 20.88	600.2 23.63	117.5 4.625	711.2 28.00	190.5 7.50	63.5 2.50	24 1	85.1 3.35	224.3 8.83	129.0 5.08	5.6 0.22	214.1 8.43	170.1 375	
QMPG30J515S	5 15/16 in.																		
QMPG30J600S	6 in.																		
QMPG30J150S	150 mm	23234	200.0 7.875	400.1 15.75	235.0 9.25	549.4 21.63	619.3 24.38	114.3 4.50	711.2 28.00	190.5 7.50	73.2 2.88	30 1 1/4	85.1 3.35	224.3 8.83	129.0 5.08	5.6 0.22	214.1 8.43	170.1 375	
QMPG34J607S	6 7/16 in.																		
QMPG34J608S	6 1/2 in.																		
QMPG34J170S	170 mm																		

SPHERICAL ROLLER BEARING SOLID-BLOCK HOUSED UNITS

EC SERIES • QMPX 5000 SERIES FOUR-BOLT PILLOW BLOCKS

QMPX 5000 SERIES FOUR-BOLT PILLOW BLOCKS

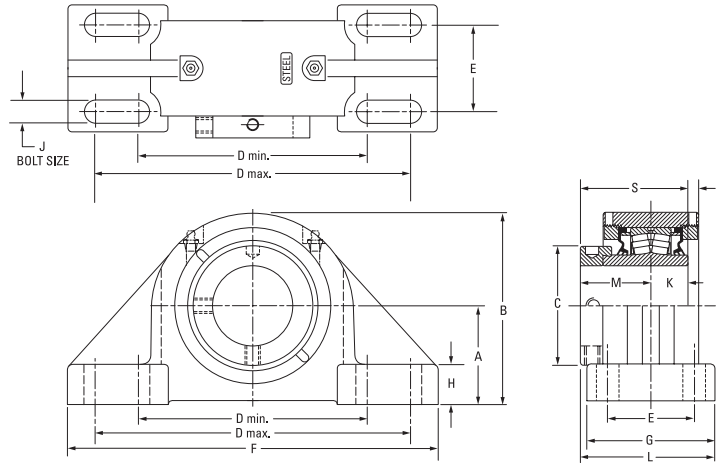

Bearing Part No.	Shaft Dia.	Bearing No.	A	B	C	D min.	D max.	E	F	G	H	J	K	L	M	R	S	Wt.
	mm in.		mm in.	mm in.	mm in.	mm in.	mm in.	mm in.	mm in.	mm in.	mm in.	mm in.	mm in.	mm in.	mm in.	mm in.	mm in.	kg lbs.
QMPX13J060S	60 mm	22213	76.2 3.00	153.7 6.05	91.9 3.62	176.3 6.94	242.8 9.56	66.8 2.63	285.8 11.25	98.6 3.88	31.0 1.22	16 5/8	31.5 1.24	103.4 4.07	54.1 2.13	5.3 0.21	85.6 3.37	10.4 23
QMPX13J207S	2 7/16 in.																	
QMPX13J208S	2 1/2 in.																	
QMPX13J065S	65 mm	22215	88.9 3.50	173.5 6.83	101.9 4.01	230.1 9.06	265.2 10.44	68.9 2.75	330.2 13.00	108.0 4.25	39.1 1.54	20 3/4	31.8 1.25	114.3 4.50	60.2 2.37	7.1 0.28	91.9 3.62	12.7 28
QMPX15J211S	2 11/16 in.																	
QMPX15J212S	2 3/4 in.																	
QMPX15J070S	70 mm	22218	101.6 4.00	201.2 7.92	120.9 4.76	274.6 10.81	309.6 12.19	76.2 3.00	381.0 15.00	120.7 4.75	38.1 1.50	20 3/4	36.6 1.44	126.0 4.96	65.8 2.59	8.1 0.32	102.4 4.03	22.2 49
QMPX18J303S	3 3/16 in.																	
QMPX18J304S	3 1/4 in.																	
QMPX18J080S	80 mm	22220	127.0 5.00	239.8 9.44	152.4 6.00	317.5 12.50	355.6 14.00	88.9 3.50	425.5 16.75	139.7 5.50	41.4 1.63	24 7/8	41.4 1.63	145.3 5.72	75.2 2.96	8.6 0.34	116.6 4.59	30.4 67
QMPX18J085S	85 mm																	
QMPX18J307S	3 7/16 in.																	
QMPX18J308S	3 1/2 in.	22222	146.1 5.75	273.8 10.78	160.0 6.30	354.1 13.94	395.2 15.56	101.6 4.00	469.9 18.50	158.8 6.25	45.7 1.80	24 1	46.5 1.83	171.2 6.74	94.0 3.70	2.3 0.09	140.5 5.53	37.2 82
QMPX18J090S	90 mm																	
QMPX20J311S	3 11/16 in.																	
QMPX20J312S	3 3/4 in.	22226	155.6 6.125	283.2 11.15	175.0 6.89	387.4 15.25	425.5 16.75	108.0 4.25	514.4 20.25	171.5 6.75	50.8 2.00	24 1 1/8	58.7 2.31	180.3 7.10	94.5 3.72	-1.5 -0.06	153.4 6.04	60.8 134
QMPX20J400S	4 in.																	
QMPX20J100S	100 mm																	
QMPX22J110S	110 mm	23230	169.9 6.688	330.2 13.00	205.0 8.07	439.9 17.32	485.8 19.125	93.5 3.68	558.8 22.00	171.5 6.75	76.2 3.00	24 1 1/8	75.9 2.99	201.7 7.94	116.1 4.57	6.6 0.26	192.0 7.56	113.4 250
QMPX22J407S	4 7/16 in.																	
QMPX22J408S	4 1/2 in.																	
QMPX22J115S	115 mm	23234	179.4 7.063	339.9 13.38	205.0 8.07	489.0 19.25	552.5 21.75	106.4 4.188	625.7 24.75	171.5 6.75	85.6 3.37	24 1 1/8	75.9 2.99	196.9 7.75	116.1 4.57	4.8 0.19	192.0 7.56	113.4 250
QMPX26J125S	125 mm																	
QMPX26J415S	4 15/16 in.																	
QMPX26J500S	5 in.	23234	200.0 7.875	400.1 15.75	235.0 9.25	549.4 21.63	619.3 24.38	112.8 4.44	711.2 28.00	190.5 7.50	73.2 2.88	30 1 1/4	80.1 3.35	224.3 8.83	129.0 5.08	5.6 0.22	214.1 8.43	179.2 395
QMPX26J130S	130 mm																	
QMPX30J507S	5 7/16 in.																	
QMPX30J508S	5 1/2 in.	23234	179.4 7.063	339.9 13.38	205.0 8.07	489.0 19.25	552.5 21.75	106.4 4.188	625.7 24.75	171.5 6.75	85.6 3.37	24 1 1/8	75.9 2.99	196.9 7.75	116.1 4.57	4.8 0.19	192.0 7.56	113.4 250
QMPX30J140S	140 mm																	
QMPX30J515S ⁽¹⁾	5 15/16 in.																	
QMPX30J600S ⁽¹⁾	6 in.	23234	200.0 7.875	400.1 15.75	235.0 9.25	549.4 21.63	619.3 24.38	112.8 4.44	711.2 28.00	190.5 7.50	73.2 2.88	30 1 1/4	80.1 3.35	224.3 8.83	129.0 5.08	5.6 0.22	214.1 8.43	179.2 395
QMPX30J150S ⁽¹⁾	150 mm																	
QMPX34J607S ⁽¹⁾	6 7/16 in.																	
QMPX34J608S ⁽¹⁾	6 1/2 in.	23234	200.0 7.875	400.1 15.75	235.0 9.25	549.4 21.63	619.3 24.38	112.8 4.44	711.2 28.00	190.5 7.50	73.2 2.88	30 1 1/4	80.1 3.35	224.3 8.83	129.0 5.08	5.6 0.22	214.1 8.43	179.2 395
QMPX34J170S ⁽¹⁾	170 mm																	
QMPX34J615S ⁽¹⁾	6 15/16 in.																	
QMPX34J700S ⁽¹⁾	7 in.	23234	200.0 7.875	400.1 15.75	235.0 9.25	549.4 21.63	619.3 24.38	112.8 4.44	711.2 28.00	190.5 7.50	73.2 2.88	30 1 1/4	80.1 3.35	224.3 8.83	129.0 5.08	5.6 0.22	214.1 8.43	179.2 395
QMPX34J180S ⁽¹⁾	180 mm																	

⁽¹⁾No gussets on outside housing.

QMPXT 5000 SERIES TWO-BOLT PILLOW BLOCKS

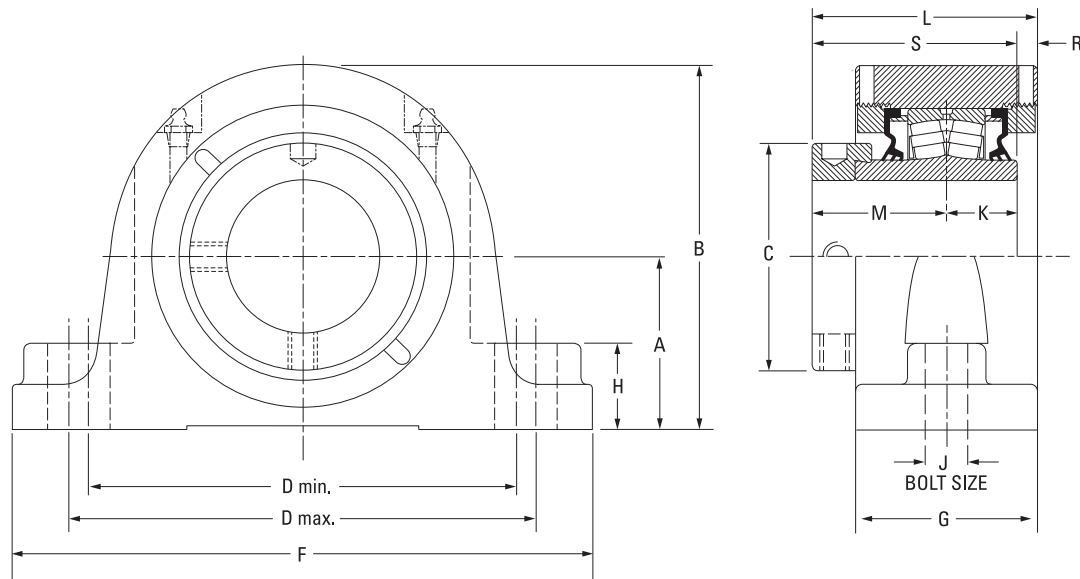

Bearing Part No.	Shaft Dia.	Bearing No.	A	B	C	D min.	D max.	F	G	H	J	K	L	M	R	S	Wt.
	mm in.		mm in.	mm in.	mm in.	mm in.	mm in.	mm in.	mm in.	mm in.	mm in.	mm in.	mm in.	mm in.	mm in.	mm in.	kg lbs.
QMPXT13J060S	60 mm	22213	76.2 3.00	153.7 6.05	91.9 3.62	194.6 7.66	223.0 8.78	285.8 11.25	73.7 2.90	35.1 1.38	20 ¾	31.5 1.24	91.4 3.60	54.1 2.13	5.3 0.21	85.6 3.37	10.0 22
QMPXT13J207S	2 7/16 in.																
QMPXT13J208S	2 1/2 in.																
QMPXT13J065S	65 mm	22215	88.9 3.50	173.7 6.84	101.9 4.01	230.1 9.06	265.2 10.44	330.2 13.00	75.7 2.98	35.1 1.38	24 7/8	31.8 1.25	98.0 3.86	60.2 2.37	6.1 0.24	91.9 3.62	12.7 28
QMPXT15J211S	2 11/16 in.																
QMPXT15J212S	2 3/4 in.																
QMPXT15J070S	70 mm																
QMPXT15J215S	2 15/16 in.																
QMPXT15J300S	3 in.																
QMPXT15J075S	75 mm																

SPHERICAL ROLLER BEARING SOLID-BLOCK HOUSED UNITS

EC SERIES • QMSN SN-STYLE TWO-BOLT PILLOW BLOCKS – PURE METRIC DESIGN

QMSN SN-STYLE TWO-BOLT PILLOW BLOCKS – PURE METRIC DESIGN

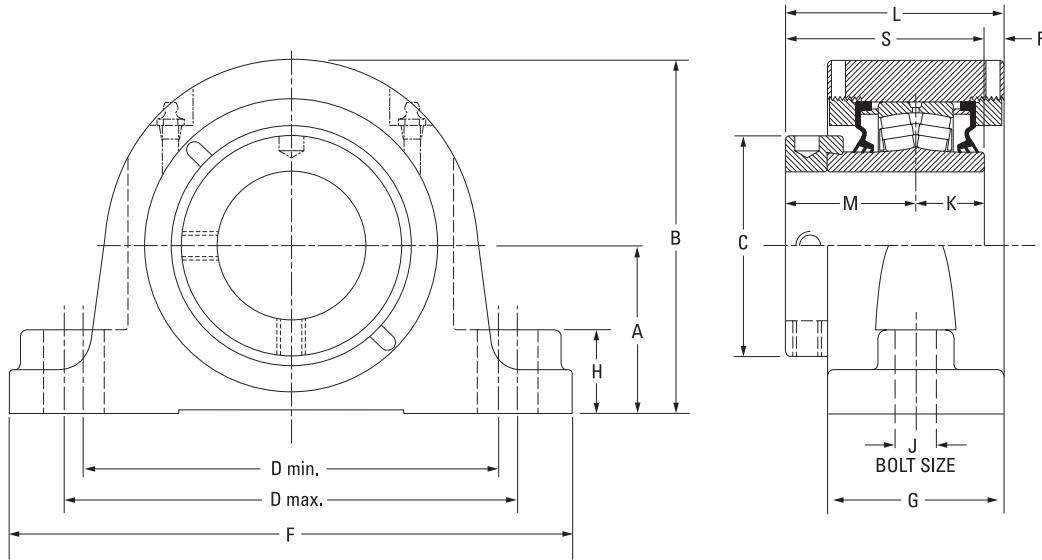

Bearing Part No.	Shaft Dia.	Bearing No.	A	B	C	D min.	D max.	F	G	H	J	K	L	M	R	S	Wt.
	mm in.		mm in.	mm in.	mm in.	mm in.	mm in.	mm in.	mm in.	mm in.	mm in.	mm in.	mm in.	mm in.	mm in.	mm in.	kg lbs.
QMSN08J035S	35 mm	22208	60	111	60.5	159	175	205	62	35	12	25	75	44	5	70	10.5
QMSN08J107S	1 7/16 in.		2.36	4.37	2.38	6.26	6.89	8.07	2.44	1.38	1/2	1.00	2.95	1.75	0.20	2.75	23
QMSN08J108S	1 1/2 in.																
QMSN09J040S	40 mm	22209	60	111	67	159	175	205	62	35	12	25	79	48	6	73	10.5
QMSN09J111S	1 11/16 in.		2.36	4.37	2.64	6.26	6.89	8.07	2.44	1.38	1/2	0.98	3.11	1.89	0.24	2.87	23
QMSN09J112S	1 3/4 in.																
QMSN09J045S	45 mm	22210	70	136	70	183	216	254	68	25	16	25	82	48	9	73	12.7
QMSN10J115S	1 15/16 in.		2.76	5.35	2.76	7.20	8.50	10.00	2.68	0.98	5/8	0.98	3.23	1.89	0.35	2.87	28
QMSN10J200S	2 in.																
QMSN10J050S	50 mm	22211	70	141	76	183	216	254	68	25	16	29	85	51	6	80	13.2
QMSN11J203S	2 3/16 in.		2.76	5.55	2.99	7.20	8.50	10.00	2.68	0.98	5/8	1.14	3.35	2.01	0.24	3.15	29
QMSN11J204S	2 1/4 in.																
QMSN11J055S	55 mm	22213	80	157	92	196	235	275	74	35	16	31	91	55	5	86	15.9
QMSN13J060S	2 7/16 in.		3.15	6.18	3.62	7.72	9.25	10.83	2.91	1.38	5/8	1.22	3.58	2.17	0.20	3.39	35
QMSN13J208S	2 1/2 in.																
QMSN13J065S	65 mm	22215	95	183	102	241	279	316	76	34	20	32	98	60	6	92	20.9
QMSN15J211S	2 11/16 in.		3.74	7.20	4.02	9.49	10.98	12.44	2.99	1.34	3/4	1.26	3.86	2.36	0.24	3.62	46
QMSN15J212S	2 3/4 in.																
QMSN15J070S	70 mm	22218	100	200	121	279	292	345	86	39	20	37	109	66	7	103	25.5
QMSN15J215S	2 15/16 in.		3.94	7.87	4.76	10.98	11.50	13.58	3.39	1.54	3/4	1.46	4.29	2.60	0.28	4.06	56
QMSN15J300S	3 in.																
QMSN15J075S	75 mm	22218	100	200	121	279	292	345	86	39	20	37	109	66	7	103	25.5
QMSN18J303S	3 3/16 in.		3.94	7.87	4.76	10.98	11.50	13.58	3.39	1.54	3/4	1.46	4.29	2.60	0.28	4.06	56
QMSN18J304S	3 1/4 in.																
QMSN18J080S	80 mm																

Continued on next page.

SPHERICAL ROLLER BEARING SOLID-BLOCK HOUSED UNITS

EC SERIES • QMSN SN-STYLE TWO-BOLT PILLOW BLOCKS – PURE METRIC DESIGN

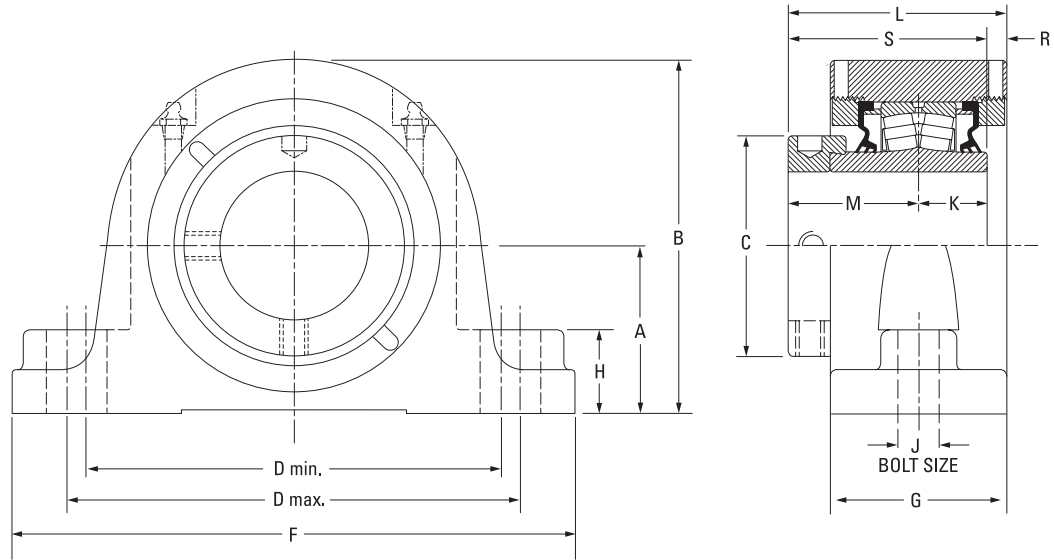

Continued from previous page.

Bearing Part No.	Shaft Dia.	Bearing No.	A	B	C	D min.	D max.	F	G	H	J	K	L	M	R	S	Wt.
	mm in.		mm in.	mm in.	mm in.	mm in.	mm in.	mm in.	mm in.	mm in.	mm in.	mm in.	mm in.	mm in.	mm in.	mm in.	kg lbs.
QMSN18J085S	85 mm	22218	112 4.41	212 8.35	121 4.76	279 10.98	292 11.50	345 13.58	86 3.39	39 1.54	20 ¾	37 1.46	109 4.29	66 2.60	7 0.28	103 4.06	25.5 56
QMSN18J307S	3 7/16 in.	22218	112 4.41	212 8.35	121 4.76	290 11.42	327 12.87	380 14.96	86 3.39	39 1.54	24 ¾	37 1.46	109 4.29	66 2.60	7 0.28	103 4.06	25.5 56
QMSN18J308S	3 1/2 in.																
QMSN18J090S	90 mm																
QMSN20J311S	3 11/16 in.	22220	125 4.92	241 9.49	152 5.98	319 12.56	366 14.41	410 16.14	101 3.98	50 1.97	24 ¾	41 1.61	126 4.96	75 2.95	9 0.35	116 4.57	35.9 79
QMSN20J312S	3 ¾ in.																
QMSN20J315S	3 15/16 in.																
QMSN20J400S	4 in.																
QMSN20J100S	100 mm																
QMSN22J110S	110 mm	22222	140 5.51	255 10.04	160 6.30	332 13.07	365 14.37	410 16.14	105 4.13	39 1.54	24 ¾	47 1.85	147 5.79	94 3.70	6 0.24	141 5.55	35.9 79
QMSN22J407S	4 7/16 in.	22222	150 5.91	265 10.43	160 6.30	367 14.45	400 15.75	445 17.52	105 4.13	49 1.93	24 ¾	47 1.85	147 5.79	94 3.70	6 0.24	141 5.55	35.5 78
QMSN22J408S	4 1/2 in.																
QMSN22J115S	115 mm																
QMSN26J125S	125 mm	22226	150 5.91	282 11.10	175 6.89	402 15.83	435 17.13	500 19.69	113 4.45	49 1.93	30 1 ¼	58 2.28	151 5.94	95 3.74	2 0.08	153 6.02	40.0 88
QMSN26J415S	4 15/16 in.																
QMSN26J500S	5 in.																
QMSN26J130S	130 mm																

SPHERICAL ROLLER BEARING SOLID-BLOCK HOUSED UNITS

EC SERIES • QMC PILOTED FLANGE CARTRIDGES

QMC PILOTED FLANGE CARTRIDGES

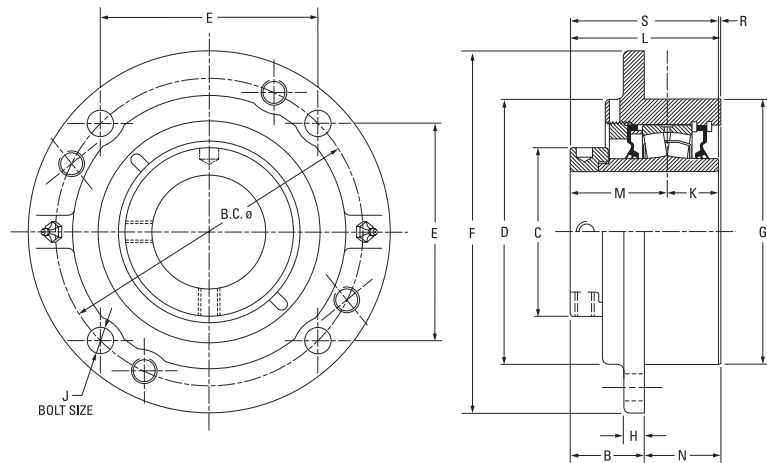

Bearing Part No.	Shaft Dia.	Bearing No.	B _{FIX}	B _{EXP}	B.C.	C	D	E	F	G ⁽¹⁾	H	J	K	L _{FIX}	L _{EXP}	M	N	R	S	Wt.	
	mm in.		mm in.	mm in.	mm in.	mm in.	mm in.	mm in.	mm in.	mm in.	mm in.	mm in.	mm in.	mm in.	mm in.	mm in.	mm in.	mm in.	mm in.	mm in.	kg lbs.
QMC08J035S	35 mm	22208	49.8	51.8	111.3	60.5	92.2	78.5	133.4	92.1	12.7	10	25.4	73.7	75.7	44.5	23.9	3.81	69.9	3.6	
QMC08J107S	1 7/16 in.		1.96	2.04	4.38	2.38	3.63	3.09	5.25	3.625	0.50	7/16	1.00	2.90	2.98	1.75	0.94	0.15	2.75	8	
QMC08J108S	1 1/2 in.																				
QMC09J040S	40 mm	22209	54.6	56.6	130.3	66.8	111.3	91.9	155.7	108.0	12.7	10	25.4	77.0	79.0	47.5	22.4	3.81	72.9	4.1	
QMC09J111S	1 11/16 in.		2.15	2.23	5.13	2.63	4.38	3.62	6.13	4.250	0.50	7/16	1.00	3.03	3.11	1.87	0.88	0.15	2.87	9	
QMC09J112S	1 3/4 in.																				
QMC09J045S	45 mm	22210	50.4	52.6	136.7	70.1	113.5	96.5	162.1	114.3	16.0	10	25.4	77.5	79.5	47.5	26.9	4.6	72.9	4.5	
QMC10J115S	1 15/16 in.		1.99	2.07	5.38	2.76	4.47	3.80	6.38	4.500	0.63	7/16	1.00	3.05	3.13	1.87	1.06	0.18	2.87	10	
QMC10J200S	2 in.																				
QMC10J050S	50 mm	22211	54.4	56.4	152.4	75.9	127.0	107.7	185.4	127.0	14.7	12	28.7	83.1	85.1	50.5	28.7	3.6	79.2	5.9	
QMC11J203S	2 3/16 in.		2.14	2.22	6.00	2.99	5.00	4.24	7.30	5.000	0.58	1/2	1.13	3.27	3.35	1.99	1.13	0.14	3.12	13	
QMC11J204S	2 1/4 in.																				
QMC11J055S	55 mm	22213	59.4	61.5	165.1	91.9	139.7	116.8	193.8	139.7	17.5	12	31.5	87.9	91.2	54.1	28.7	2.3	85.6	7.3	
QMC13J207S	2 7/16 in.		2.34	2.42	6.50	3.62	5.50	4.60	7.63	5.500	0.69	1/2	1.24	3.46	3.59	2.13	1.13	0.09	3.37	16	
QMC13J208S	2 1/2 in.																				
QMC13J065S	65 mm	22215	62.5	64.5	190.5	101.9	162.1	134.6	222.3	161.9	20.6	16	31.8	94.5	96.5	60.2	31.8	2.3	91.9	10.0	
QMC15J211S	2 11/16 in.		2.46	2.54	7.50	4.01	6.38	5.30	8.75	6.375	0.81	5/8	1.25	3.72	3.80	2.37	1.25	0.09	3.62	22	
QMC15J212S	2 3/4 in.																				
QMC15J070S	70 mm	22218	73.2	75.2	219.2	120.9	187.5	154.9	262.6	187.3	25.4	20	36.6	106.4	108.5	65.8	33.3	4.1	102.4	14.5	
QMC15J300S	3 in.		2.88	2.96	8.63	4.76	7.38	6.10	10.34	7.375	1.00	3/4	1.44	4.19	4.27	2.59	1.31	0.16	4.03	32	
QMC15J075S	75 mm																				
QMC18J303S	3 3/16 in.	22220	72.1	74.2	238.3	152.4	206.5	168.4	276.4	206.4	25.4	20	41.4	126.0	128.0	75.2	54.1	9.4	115.8	19.5	
QMC18J304S	3 1/4 in.		2.84	2.92	9.38	6.00	8.13	6.63	10.88	8.125	1.00	3/4	1.63	4.96	5.04	2.96	2.13	0.37	4.56	43	
QMC18J080S	80 mm																				
QMC18J085S	85 mm	22222	92.5	94.5	298.5	160.0	254.0	149.4	342.9	260.4	25.4	20	46.5	140.7	142.7	94.0	48.3	0.3	140.5	32.7	
QMC18J307S	3 7/16 in.		3.64	3.72	11.75 ⁽²⁾	6.30	10.00	5.88 ⁽²⁾	13.50	10.250	1.00	3/4 ⁽²⁾	1.83	5.54	5.62	3.70	1.90	0.01	5.53	72	
QMC18J308S	3 1/2 in.																				
QMC18J090S	90 mm																				
QMC20J311S	3 11/16 in.	22222	92.5	94.5	298.5	160.0	254.0	149.4	342.9	260.4	25.4	20	46.5	140.7	142.7	94.0	48.3	0.3	140.5	32.7	
QMC20J312S	3 3/4 in.		3.64	3.72	11.75 ⁽²⁾	6.30	10.00	5.88 ⁽²⁾	13.50	10.250	1.00	3/4 ⁽²⁾	1.83	5.54	5.62	3.70	1.90	0.01	5.53	72	
QMC20J315S	3 15/16 in.																				
QMC20J400S	4 in.																				
QMC20J100S	100 mm																				
QMC22J110S ⁽²⁾	110 mm																				
QMC22J407S ⁽²⁾	4 7/16 in.																				
QMC22J408S ⁽²⁾	4 1/2 in.																				
QMC22J115S ⁽²⁾	115 mm																				

⁽¹⁾Pilot tolerance: +0/-0.051 mm (+0/-0.002 in.).

⁽²⁾Six-bolt housing.

QMCW PILOTED FLANGE CARTRIDGES

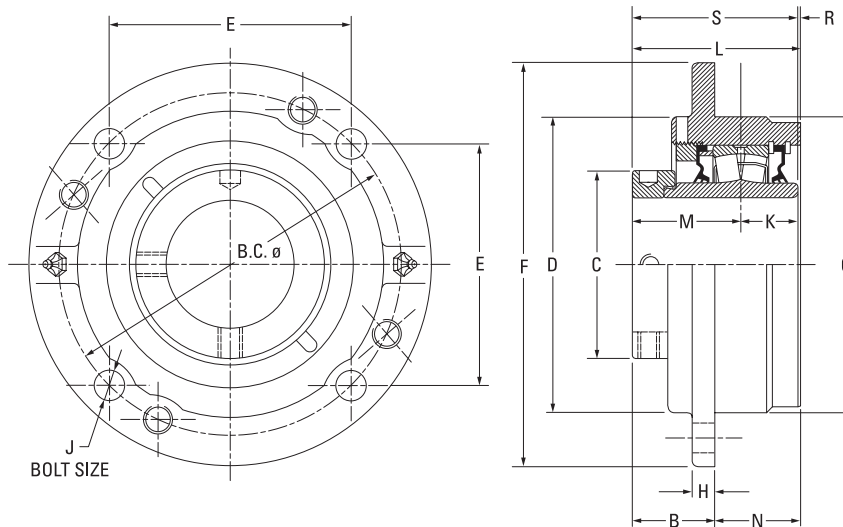

Bearing Part No.	Shaft Dia.	Bearing No.	B	B	B.C.	C	D	E	F	G ⁽¹⁾	H	J	K	L	L	M	N	R	S	Wt.	
			FIX	EXP	mm	mm	mm	mm	mm	mm	mm	mm	mm	mm	mm	mm	mm	mm	mm	mm	mm
			in.	in.	in.	in.	in.	in.	in.	in.	in.	in.	in.	in.	in.	in.	in.	in.	in.	in.	lbs.
QMCW08J035S	35 mm	22208	38.6	40.9	111.3	59.9	92.2	78.5	133.4	92.1	12.7	10	25.4	73.7	75.7	44.5	35.1	3.8	69.9	3.6	
QMCW08J107S	1 7/16 in.		1.53	1.61	4.38	2.36	3.63	3.09	5.25	3.625	0.50	7/16	1.00	2.90	2.98	1.75	1.38	0.15	2.75	8	
QMCW08J108S	1 1/2 in.																				
QMCW09J040S	40 mm	22209	38.9	40.1	130.3	66.8	111.3	91.9	155.7	108.0	10.2	10	25.1	77.0	78.2	47.8	38.1	4.1	72.9	4.1	
QMCW09J111S	1 11/16 in.		1.53	1.58	5.13	2.63	4.38	3.62	6.13	4.250	0.40	7/16	0.99	3.03	3.08	1.88	1.50	0.16	2.87	9	
QMCW09J112S	1 3/4 in.																				
QMCW09J045S	45 mm	22210	39.1	41.1	136.7	70.1	113.5	96.5	162.1	114.3	9.7	10	24.9	77.2	79.2	48.0	38.1	4.3	72.9	4.5	
QMCW10J115S	1 15/16 in.		1.54	1.62	5.38	2.76	4.47	3.80	6.38	4.500	0.38	7/16	0.98	3.04	3.12	1.89	1.50	0.17	2.87	10	
QMCW10J200S	2 in.																				
QMCW10J050S	50 mm	22211	45.7	47.8	152.4	75.9	127.0	107.7	181.1	127.0	14.2	12	28.7	86.9	88.9	50.5	41.4	7.62	79.2	5.9	
QMCW11J203S	2 3/16 in.		1.80	1.88	6.00	2.99	5.00	4.24	7.13	5.000	0.56	1/2	1.13	3.42	3.50	1.99	1.63	0.30	3.12	13	
QMCW11J204S	2 1/4 in.																				
QMCW11J055S	55 mm	22213	47.5	49.5	165.1	91.9	139.7	116.8	193.8	139.7	12.7	12	31.5	90.2	92.2	54.1	42.9	4.31	85.6	7.3	
QMCW13J060S	60 mm		1.87	1.95	6.50	3.62	5.50	4.60	7.63	5.500	0.50	1/2	1.24	3.55	3.63	2.13	1.69	0.17	3.37	16	
QMCW13J207S	2 7/16 in.																				
QMCW13J208S	2 1/2 in.	22215	46.0	48.0	190.5	101.9	162.1	134.6	222.3	161.9	12.7	16	31.8	93.5	95.5	60.2	47.8	1.5	91.9	10.0	
QMCW13J065S	65 mm		1.81	1.89	7.50	4.01	6.38	5.30	8.75	6.375	0.50	5/8	1.25	3.68	3.76	2.37	1.88	0.06	3.62	22	
QMCW15J211S	2 11/16 in.																				
QMCW15J212S	2 3/4 in.	22218	62.5	64.5	219.2	120.9	187.5	154.9	260.4	187.3	22.4	20	36.6	110.2	112.3	65.8	47.8	7.9	102.4	14.5	
QMCW15J070S	70 mm		2.46	2.54	8.63	4.76	7.38	6.10	10.25	7.375	0.88	3/4	1.44	4.34	4.42	2.59	1.88	0.31	4.03	32	
QMCW15J215S	2 15/16 in.																				
QMCW15J300S	3 in.	22218																			
QMCW15J075S	75 mm																				
QMCW18J303S	3 3/16 in.																				
QMCW18J304S	3 1/4 in.																				
QMCW18J080S	80 mm																				
QMCW18J085S	85 mm																				
QMCW18J307S	3 7/16 in.																				
QMCW18J308S	3 1/2 in.																				
QMCW18J090S	90 mm																				

⁽¹⁾Pilot tolerance: +0/-0.05 mm (+0/-0.002 in.).

⁽²⁾Six-bolt housing.

Continued on next page.

SPHERICAL ROLLER BEARING SOLID-BLOCK HOUSED UNITS

EC SERIES • QMCW PILOTED FLANGE CARTRIDGES

QMCW PILOTED FLANGE CARTRIDGES – continued

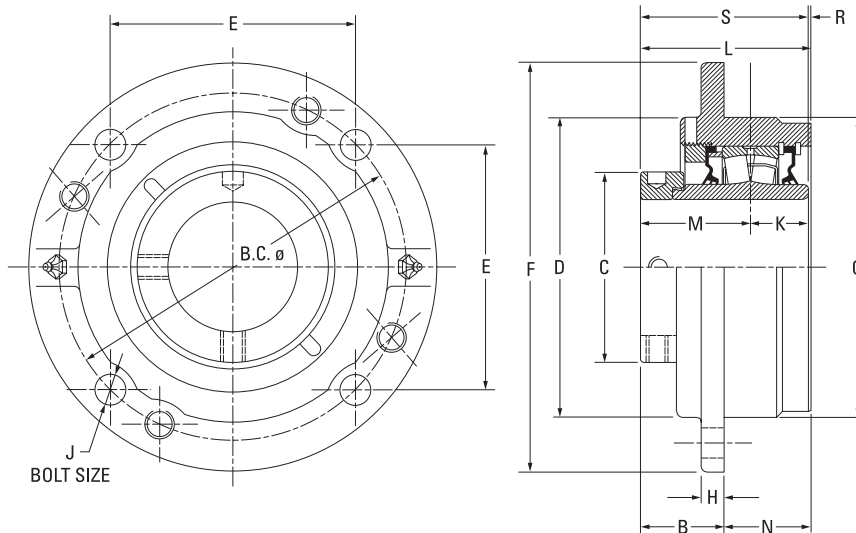

Continued from previous page.

Bearing Part No.	Shaft Dia.	Bearing No.	B _{FIX}	B _{EXP}	B.C.	C	D	E	F	G ⁽¹⁾	H	J	K	L _{FIX}	L _{EXP}	M	N	R	S	Wt.	
	mm in.		mm in.	mm in.	mm in.	mm in.	mm in.	mm in.	mm in.	mm in.	mm in.	mm in.	mm in.	mm in.	mm in.	mm in.	mm in.	mm in.	mm in.	mm in.	kg lbs.
QMCW20J311S	3 11/16 in.	22220	63.5 2.50	65.5 2.58	238.3 9.38	152.4 6.00	206.5 8.13	168.4 6.63	276.4 10.88	206.4 8.125	25.4 1.00	20 3/4	41.4 1.63	120.7 4.75	122.7 4.83	75.2 2.96	57.2 2.25	4.1 0.16	116.6 4.59	19.5 43	
QMCW20J312S	3 3/4 in.																				
QMCW20J315S	3 15/16 in.																				
QMCW20J400S	4 in.																				
QMCW20J100S	100 mm	22222	76.5 3.01	78.5 3.09	298.5 11.75 ⁽²⁾	160.0 6.30	254.0 10.00	149.4 5.88 ⁽²⁾	342.9 13.50	260.4 10.250	25.4 1.00	20 3/4 ⁽²⁾	46.5 1.83	144.8 5.70	146.8 5.78	94.0 3.70	68.3 2.69	4.3 0.17	140.5 5.53	32.7 72	
QMCW22J110S ⁽²⁾	110 mm																				
QMCW22J407S ⁽²⁾	4 7/16 in.																				
QMCW22J408S ⁽²⁾	4 1/2 in.																				
QMCW22J115S ⁽²⁾	115 mm	22226	73.7 2.90	75.7 2.98	323.9 12.75 ⁽²⁾	175.0 6.89	266.7 10.50	162.1 6.38 ⁽²⁾	374.7 14.75	279.4 11.000	26.2 1.03	24 7/8 ⁽²⁾	58.7 2.31	151.4 5.96	153.4 6.04	94.7 3.73	77.9 3.065	-1.8 -0.07	153.4 6.04	46.3 102	
QMCW26J415S ⁽²⁾	4 15/16 in.																				
QMCW26J500S ⁽²⁾	5 in.																				
QMCW26J130S ⁽²⁾	130 mm																				
QMCW30J507S ⁽²⁾	5 7/16 in.	23230	82.8 3.26	84.8 3.34	368.3 14.50 ⁽²⁾	205.0 8.07	304.8 12.00	184.2 7.25 ⁽²⁾	431.8 17.00	330.2 13.000	26.2 1.03	24 7/8 ⁽²⁾	75.9 2.99	204.2 8.04	206.2 8.12	116.1 4.57	121.4 4.78	12.2 0.48	192.0 7.56	102.5 226	
QMCW30J508S ⁽²⁾	5 1/2 in.																				
QMCW30J140S ⁽²⁾	140 mm																				
QMCW30J515S ⁽²⁾	5 15/16 in.																				
QMCW30J600S ⁽²⁾	6 in.	23234	82.8 3.26	84.8 3.34	419.1 16.50 ⁽²⁾	205.0 8.07	304.8 12.00	209.6 8.25 ⁽²⁾	482.6 19.00	355.6 14.000	26.2 1.03	24 7/8 ⁽²⁾	75.9 2.99	211.3 8.32	213.4 8.40	116.1 4.57	128.5 5.06	19.3 0.76	192.0 7.56	101.6 224	
QMCW30J150S ⁽²⁾	150 mm																				
QMCW34J607S ⁽²⁾	6 7/16 in.																				
QMCW34J608S ⁽²⁾	6 1/2 in.																				
QMCW34J170S ⁽²⁾	170 mm	23234	85.9 3.38	87.9 3.46	431.8 17.00	235.0 9.25	355.6 14.00	215.9 8.50	482.6 19.00	381.0 15.000	28.7 1.13	24 1 ⁽²⁾	85.1 3.35	216.2 8.51	218.2 8.59	129.0 5.08	130.3 5.13	2.0 0.08	214.1 8.43	152.4 336	
QMCW34J615S ⁽²⁾	6 15/16 in.																				
QMCW34J700S ⁽²⁾	7 in.																				
QMCW34J180S ⁽²⁾	180 mm																				

⁽¹⁾Pilot tolerance: +0/-0.05 mm (+0/-0.002 in.).

⁽²⁾Six-bolt housing.

QMF FOUR-BOLT SQUARE FLANGE BLOCKS

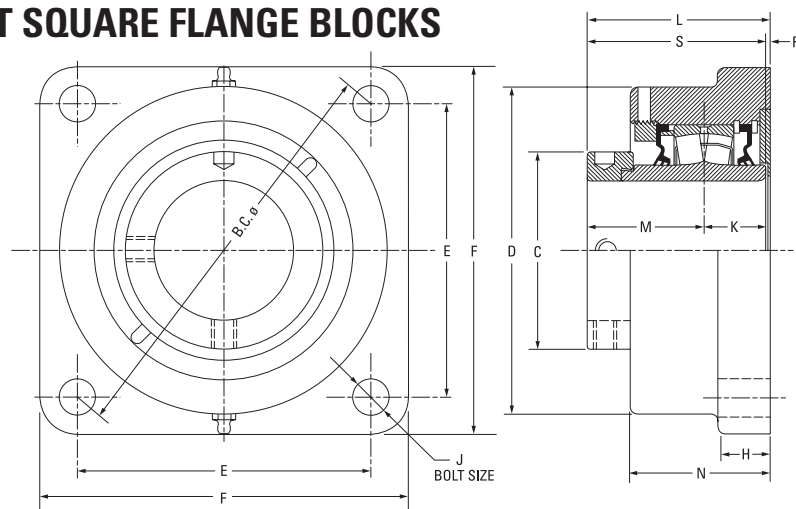

Bearing Part No.	Shaft Dia.	Bearing No.	B.C.	C	D	E	F	H	J	K	L FIX	L EXP	M	N	R	S	Wt.
	mm in.		mm in.	mm in.	mm in.	mm in.	mm in.	mm in.	mm in.	mm in.	mm in.	mm in.	mm in.	mm in.	mm in.	mm in.	lbs. kg
QMF08J035S	35 mm	22208	127.7	60.5	93.7	88.9	117.6	22.4	12	25.4	72.9	74.9	44.5	57.2	3.0	69.9	4.5
QMF08J107S	1 7/16 in.		4.95	2.38	3.69	3.50	4.63	0.88	1/2	1.00	2.87	2.95	1.75	2.25	0.12	2.75	10
QMF08J108S	1 1/2 in.	22208	148.3	60.5	108.0	104.9	136.7	22.4	12	25.4	73.7	75.7	44.5	59.4	3.8	69.9	4.5
QMF09J111S	1 11/16 in.		5.84	2.38	4.25	4.13	5.38	0.88	1/2	1.00	2.90	2.98	1.75	2.34	0.15	2.75	10
QMF09J040S	40 mm	22209	148.3	66.8	118.4	104.9	136.7	22.4	12	25.4	79.5	81.5	47.8	63.5	6.4	73.2	5.0
QMF09J112S	1 3/4 in.		5.84	2.63	4.66	4.13	5.38	0.88	1/2	1.00	3.13	3.21	1.88	2.50	0.25	2.88	11
QMF09J045S	45 mm	22209	157.2	66.8	118.4	111.3	143.0	22.4	12	25.4	79.5	81.5	47.8	63.5	6.4	72.9	5.0
QMF10J115S	1 15/16 in.		6.19	2.63	4.66	4.38	5.63	0.88	1/2	1.00	3.13	3.21	1.88	2.50	0.25	2.87	11
QMF10J200S	2 in.	22210	157.2	70.1	120.7	111.3	139.7	22.4	12	24.4	80.8	82.8	48.0	65.0	7.9	72.9	5.0
QMF10J050S	50 mm		6.19	2.76	4.75	4.38	5.50	0.88	1/2	0.98	3.18	3.26	1.89	2.56	0.31	2.87	11
QMF11J203S	2 3/16 in.	22211	175.0	75.9	130.3	124.0	157.2	25.4	16	28.7	82.8	84.8	50.5	66.8	3.3	79.2	6.4
QMF11J204S	2 1/4 in.		6.89	2.99	5.13	4.88	6.19	1.00	5/8	1.13	3.26	3.34	1.99	2.63	0.13	3.12	14
QMF11J055S	55 mm																
QMF13J060S	60 mm	22213	193.0	91.9	146.1	136.7	168.4	25.4	16	31.5	88.6	90.7	54.1	72.4	3.0	85.6	7.7
QMF13J207S	2 7/16 in.		7.60	3.62	5.75	5.38	6.63	1.00	5/8	1.24	3.49	3.57	2.13	2.85	0.12	3.37	17
QMF13J208S	2 1/2 in.																
QMF13J065S	65 mm	22215	215.6	101.9	168.9	152.4	189.0	26.9	20	31.8	96.0	98.0	60.2	76.2	4.1	91.9	10.4
QMF15J211S	2 11/16 in.		8.49	4.01	6.65	6.00	7.44	1.06	3/4	1.25	3.78	3.86	2.37	3.00	0.16	3.62	23
QMF15J212S	2 3/4 in.																
QMF15J070S	70 mm	22218	251.7	120.9	193.8	177.8	219.2	33.3	20	36.6	107.2	109.2	66.8	84.1	4.8	102.4	15.9
QMF15J215S	2 15/16 in.		9.91	4.76	7.63	7.00	8.63	1.31	3/4	1.44	4.22	4.30	2.59	3.31	0.19	4.03	35
QMF15J300S	3 in.																
QMF15J075S	75 mm	22220	278.4	152.4	224.0	196.9	253.2	38.1	24	41.4	126.2	128.3	75.2	103.1	9.4	116.6	24.9
QMF18J303S	3 3/16 in.		10.96	6.00	8.82	7.75	9.97	1.50	7/8	1.63	4.97	5.05	2.96	4.06	0.37	4.59	55
QMF18J304S	3 1/4 in.																
QMF18J080S	80 mm	22222	314.5	160.0	256.8	222.3	276.4	38.1	24	46.5	150.1	152.1	94.0	106.9	9.7	140.5	28.6
QMF18J085S	85 mm		12.38	6.30	10.11	8.75	10.88	1.50	7/8	1.83	5.91	5.99	3.70	4.21	0.38	5.53	63
QMF18J307S	3 7/16 in.																
QMF18J308S	3 1/2 in.																
QMF18J090S	90 mm	22222	314.5	160.0	256.8	222.3	276.4	38.1	24	46.5	150.1	152.1	94.0	106.9	9.7	140.5	28.6
QMF20J311S	3 11/16 in.		12.38	6.30	10.11	8.75	10.88	1.50	7/8	1.83	5.91	5.99	3.70	4.21	0.38	5.53	63
QMF20J312S	3 3/4 in.																
QMF20J315S	3 15/16 in.	22222	314.5	160.0	256.8	222.3	276.4	38.1	24	46.5	150.1	152.1	94.0	106.9	9.7	140.5	28.6
QMF20J400S	4 in.		12.38	6.30	10.11	8.75	10.88	1.50	7/8	1.83	5.91	5.99	3.70	4.21	0.38	5.53	63
QMF20J100S	100 mm	22222	314.5	160.0	256.8	222.3	276.4	38.1	24	46.5	150.1	152.1	94.0	106.9	9.7	140.5	28.6
QMF22J110S	110 mm		12.38	6.30	10.11	8.75	10.88	1.50	7/8	1.83	5.91	5.99	3.70	4.21	0.38	5.53	63
QMF22J407S	4 7/16 in.	22222	314.5	160.0	256.8	222.3	276.4	38.1	24	46.5	150.1	152.1	94.0	106.9	9.7	140.5	28.6
QMF22J408S	4 1/2 in.		12.38	6.30	10.11	8.75	10.88	1.50	7/8	1.83	5.91	5.99	3.70	4.21	0.38	5.53	63
QMF22J115S	115 mm																

SPHERICAL ROLLER BEARING SOLID-BLOCK HOUSED UNITS

EC SERIES • QMFL FOUR-BOLT SQUARE FLANGE BLOCKS

QMFL FOUR-BOLT SQUARE FLANGE BLOCKS

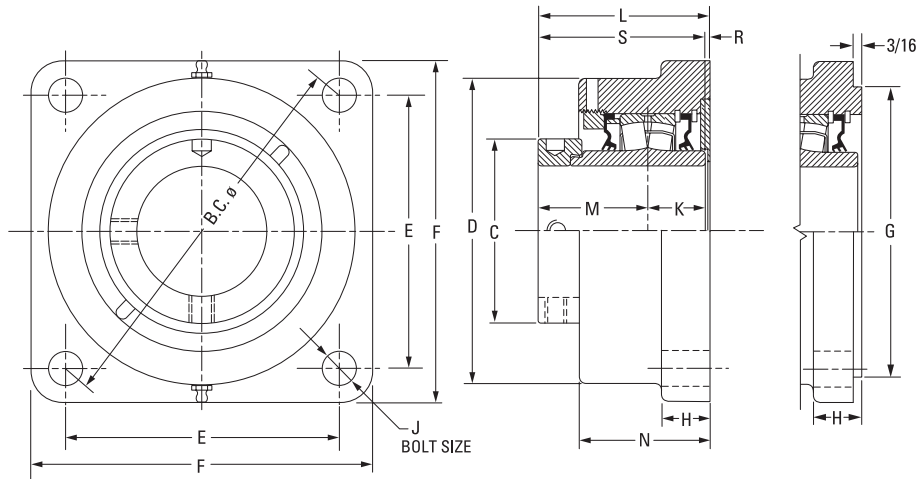

Bearing Part No.	Shaft Dia.	Bearing No.	B.C.	C	D	E	F	G ⁽¹⁾⁽²⁾⁽³⁾	H	J	K	L _{FIX}	L _{EXP}	M	N	R	S	Wt.
	mm in.		mm in.	mm in.	mm in.	mm in.	mm in.	mm in.	mm in.	mm in.	mm in.	mm in.	mm in.	mm in.	mm in.	mm in.	mm in.	kg lbs.
QMFL08J035S	35 mm	22208	127.0	60.5	93.7	89.9	117.6	N/A	22.4	12	25.4	72.9	74.9	44.5	57.2	3.0	69.9	4.5
QMFL08J107S	1 7/16 in.		5.00	2.38	3.69	3.54	4.63		0.88	1/2	1.00	2.87	2.95	1.75	2.25	0.12	2.75	10
QMFL08J108S	1 1/2 in.																	
QMFL09J111S	1 11/16 in.	22209	139.7	66.8	118.4	98.8	136.7	N/A	22.4	12	25.1	79.5	81.5	47.8	63.5	6.6	72.9	5.0
QMFL09J040S	1 3/4 in.		5.50	2.63	4.66	3.89	5.38		0.88	1/2	0.99	3.13	3.21	1.88	2.50	0.26	2.87	11
QMFL09J112S	1 3/4 in.																	
QMFL09J045S	45 mm	22210	146.1	70.1	115.3	103.4	131.8	N/A	23.1	12	24.9	80.8	82.8	48.0	62.5	7.9	72.9	5.0
QMFL10J115S	1 15/16 in.		5.75	2.76	4.54	4.07	5.19		0.91	1/2	0.98	3.18	3.26	1.89	2.46	0.31	2.87	11
QMFL10J200S	2 in.																	
QMFL10J050S	50 mm	22211	162.1	76.0	130.3	114.3	149.4	N/A	19.1	16	28.7	83.3	85.3	50.5	66.8	3.8	79.2	6.4
QMFL11J203S	2 3/16 in.		6.38	2.99	5.13	4.50	5.88		0.75	5/8	1.13	3.28	3.36	1.99	2.63	0.15	3.12	14
QMFL11J204S	2 1/4 in.																	
QMFL11J055S	55 mm	22213	171.5	91.9	146.1	121.2	157.2	N/A	25.4	16	31.5	88.9	90.7	54.1	72.6	3.0	85.6	7.7
QMFL13J060S	60 mm		6.75	3.62	5.75	4.77	6.19		1.00	5/8	1.24	3.50	3.57	2.13	2.86	0.12	3.37	17
QMFL13J207S	2 7/16 in.																	
QMFL13J208S	2 1/2 in.	22215	200.2	101.9	168.4	141.2	182.6	N/A	26.9	20	31.8	95.8	97.8	60.2	74.4	3.8	91.9	10.4
QMFL13J065S	65 mm		7.88	4.01	6.63	5.56	7.19		1.06	3/4	1.25	3.77	3.85	2.37	2.93	0.15	3.62	23
QMFL15J211S	2 11/16 in.																	
QMFL15J212S	2 3/4 in.	22218	241.3	120.9	193.8	170.7	212.9	187.33	32.5	20	36.6	106.4	108.5	65.8	86.4	4.1	102.4	15.9
QMFL15J070S	70 mm		9.50	4.76	7.63	6.72	8.38	7.375	1.28	3/4	1.44	4.19	4.27	2.59	3.40	0.16	4.03	35
QMFL15J215S	2 15/16 in.																	
QMFL15J300S	3 in.	22220	273.1	152.4	229.6	193.0	241.3	215.90	38.1	24	41.4	132.3	134.4	75.2	104.6	15.7	116.6	24.9
QMFL15J075S	75 mm		10.75	6.00	9.04	7.60	9.50	8.500	1.50	1	1.63	5.21	5.29	2.96	4.12	0.62	4.59	55
QMFL18J303S	3 3/16 in.																	
QMFL18J304S	3 1/4 in.	22218	241.3	120.9	193.8	170.7	212.9	187.33	32.5	20	36.6	106.4	108.5	65.8	86.4	4.1	102.4	15.9
QMFL18J080S	80 mm		9.50	4.76	7.63	6.72	8.38	7.375	1.28	3/4	1.44	4.19	4.27	2.59	3.40	0.16	4.03	35
QMFL18J085S	85 mm																	
QMFL18J307S	3 7/16 in.	22220	273.1	152.4	229.6	193.0	241.3	215.90	38.1	24	41.4	132.3	134.4	75.2	104.6	15.7	116.6	24.9
QMFL18J308S	3 1/2 in.		10.75	6.00	9.04	7.60	9.50	8.500	1.50	1	1.63	5.21	5.29	2.96	4.12	0.62	4.59	55
QMFL18J090S	90 mm																	
QMFL20J311S	3 11/16 in.	22220	273.1	152.4	229.6	193.0	241.3	215.90	38.1	24	41.4	132.3	134.4	75.2	104.6	15.7	116.6	24.9
QMFL20J312S	3 3/4 in.		10.75	6.00	9.04	7.60	9.50	8.500	1.50	1	1.63	5.21	5.29	2.96	4.12	0.62	4.59	55
QMFL20J315S	3 15/16 in.																	
QMFL20J400S	4 in.	22220	273.1	152.4	229.6	193.0	241.3	215.90	38.1	24	41.4	132.3	134.4	75.2	104.6	15.7	116.6	24.9
QMFL20J100S	100 mm		10.75	6.00	9.04	7.60	9.50	8.500	1.50	1	1.63	5.21	5.29	2.96	4.12	0.62	4.59	55

⁽¹⁾Pilot tolerance: +0/-0.05 mm (+0/-0.002 in.).

⁽²⁾Add (p) to the end of the housing designation in the part number to order with pilot using G dimension.

⁽³⁾Piloted flange blocks will be quoted (price and delivery) upon request. For optional spigot on flange side, insert the letter P as seen in the following example: QMFP**J***S.

QMFY ROUND FLANGE BLOCKS

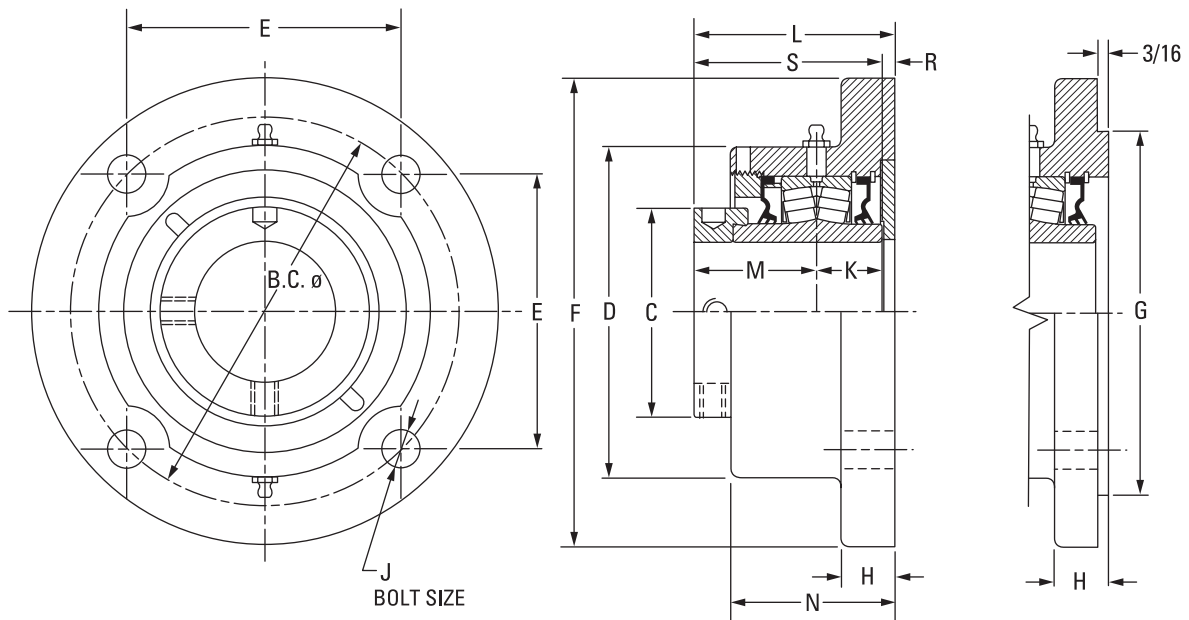

Bearing Part No.	Shaft Dia.	Bearing No.	B.C.	C	D	E	F	G ⁽¹⁾⁽²⁾⁽³⁾	H	J	K	L _{FIX}	L _{EXP}	M	N	R	S	Wt.	
	mm in.		mm in.	mm in.	mm in.	mm in.	mm in.	mm in.	mm in.	mm in.	mm in.	mm in.	mm in.	mm in.	mm in.	mm in.	mm in.	kg lbs.	
QMFY08J035S ⁽⁴⁾	35 mm	22208	127.0	60.5	108.0	88.9	158.8	90.50	19.1	12	25.4	73.2	75.2	44.5	57.4	3.3	69.9	4.5	
QMFY08J107S ⁽⁴⁾	1 7/16 in.		5.00 ⁽⁴⁾	2.38	4.25	3.54 ⁽⁴⁾	6.25	3.563	0.75	1/2 ⁽⁴⁾	1.00	2.88	2.96	1.75	2.26	0.13	2.75	10	
QMFY08J108S ⁽⁴⁾	1 1/2 in.																		
QMFY09J040S	40 mm	22209	139.7	66.8	104.9	98.8	171.5	103.20	20.6	12	25.1	76.2	78.2	47.8	60.5	3.0	72.9	5.0	
QMFY09J111S	1 11/16 in.		5.50	2.63	4.13	3.89	6.75	4.063	0.81	1/2	0.99	3.00	3.08	1.88	2.38	0.12	2.87	11	
QMFY09J045S	45 mm																		
QMFY10J115S	1 15/16 in.	22210	146.1	70.1	115.3	103.4	177.8	111.13	19.1	12	24.9	75.9	78.0	48.0	58.4	3.0	72.9	5.4	
QMFY10J200S	2 in.		5.75	2.76	4.54	4.07	7.00	4.375	0.75	1/2	0.98	2.99	3.07	1.89	2.30	0.12	2.87	12	
QMFY10J050S	50 mm																		
QMFY11J203S	2 3/16 in.	22211	162.1	75.9	130.3	114.3	196.9	127.00	19.1	16	28.7	82.3	84.3	75.9	62.0	3.0	79.2	6.8	
QMFY11J204S	2 1/4 in.		6.38	2.99	5.13	4.50	7.75	5.000	0.75	5/8	1.13	3.24	3.32	2.99	2.44	0.12	3.12	15	
QMFY11J055S	55 mm																		
QMFY13J060S	60 mm	22213	171.5	91.9	146.1	121.2	206.5	138.13	23.9	16	31.5	88.1	90.4	54.1	72.4	2.3	85.6	8.6	
QMFY13J207S	2 7/16 in.		6.75	3.62	5.75	4.77	8.13	5.438	0.94	5/8	1.24	3.47	3.56	2.13	2.85	0.09	3.37	19	
QMFY13J208S	2 1/2 in.																		
QMFY13J065S	65 mm	22215	199.9	101.9	168.4	141.2	241.3	160.35	23.9	20	31.8	98.6	100.6	60.2	76.2	6.4	91.9	12.7	
QMFY15J211S	2 11/16 in.		7.87	4.01	6.63	5.56	9.50	6.313	0.94	3/4	1.25	3.88	3.96	2.37	3.00	0.25	3.62	28	
QMFY15J212S	2 3/4 in.																		
QMFY15J070S	70 mm																		
QMFY15J215S	2 15/16 in.																		
QMFY15J300S	3 in.																		
QMFY15J075S	75 mm																		

⁽¹⁾Pilot tolerance: +0/-0.05 mm (+0/-0.002 in.).

⁽²⁾Add (p) to the end of the housing designation in the part number to order with pilot using G dimension.

⁽³⁾Piloted flange blocks will be quoted (price and delivery) upon request. For optional spigot on flange side, insert the letter P as seen in the following example: QMFY**J***S.

⁽⁴⁾Three-bolt housing.

⁽⁵⁾Six-bolt housing.

NOTE: Housings also are available with a 3/16 in. machined pilot. Please contact your Timken engineer for more information.

Continued on next page.

SPHERICAL ROLLER BEARING SOLID-BLOCK HOUSED UNITS

EC SERIES • QMFY ROUND FLANGE BLOCKS

QMFY ROUND FLANGE BLOCKS – continued

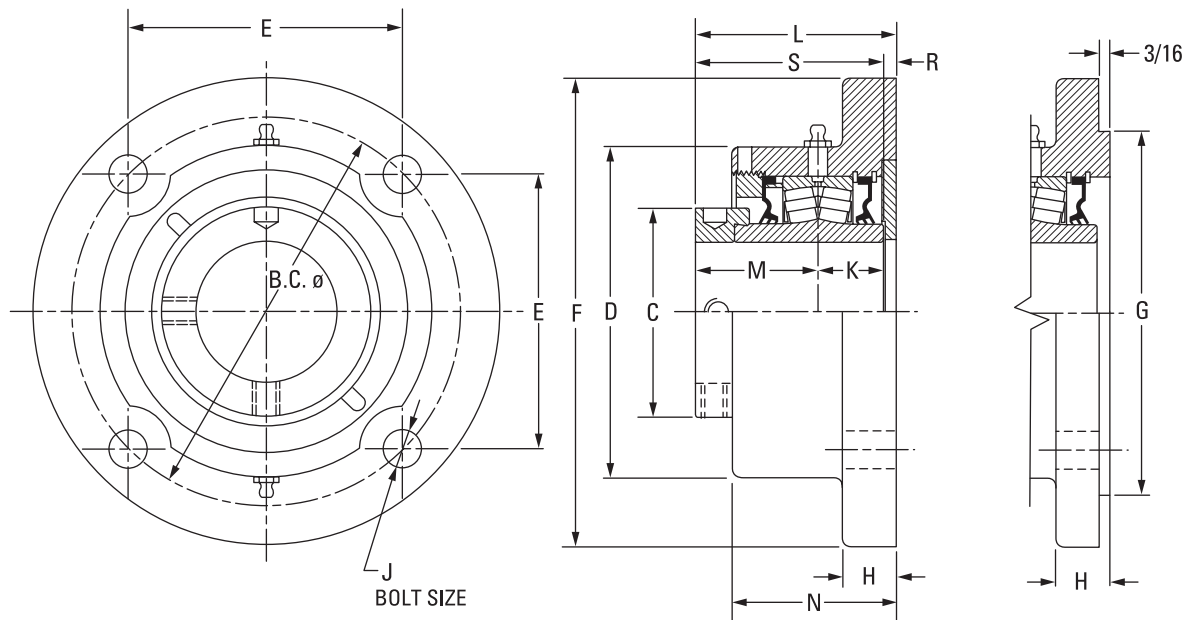

Continued from previous page.

Bearing Part No.	Shaft Dia.	Bearing No.	B.C.	C	D	E	F	G ⁽¹⁾⁽²⁾⁽³⁾	H	J	K	L _{FIX}	L _{EXP}	M	N	R	S	Wt.
	mm in.		mm in.	mm in.	mm in.	mm in.	mm in.	mm in.	mm in.	mm in.	mm in.	mm in.	mm in.	mm in.	mm in.	mm in.	mm in.	kg lbs.
QMFY18J303S	3 3/16 in.	22218	241.3 9.50	120.9 4.76	193.8 7.63	170.7 6.72	282.7 11.13	N/A	28.7 1.13	24 7/8	36.6 1.44	108.7 4.28	110.7 4.36	65.8 2.59	85.3 3.36	6.4 0.25	102.4 4.03	19.1 42
QMFY18J304S	3 1/4 in.																	
QMFY18J080S	80 mm																	
QMFY18J085S	85 mm																	
QMFY18J307S	3 7/16 in.																	
QMFY18J308S	3 1/2 in.																	
QMFY18J090S	90 mm	22220	273.1 10.75	152.4 6.00	212.9 8.38	193.0 7.60	320.8 12.63	N/A	28.7 1.13	24 1	41.4 1.63	123.7 4.87	125.7 4.95	75.2 2.96	96.8 3.81	6.9 0.27	116.6 4.59	29.9 66
QMFY20J311S	3 11/16 in.																	
QMFY20J312S	3 3/4 in.																	
QMFY20J315S	3 15/16 in.																	
QMFY20J400S	4 in.																	
QMFY20J100S	100 mm																	
QMFY22J110S ⁽⁵⁾	110 mm	22222	327.2 12.88 ⁽⁵⁾	160.0 6.30	254.0 10.00	163.6 6.44 ⁽⁵⁾	384.3 15.13	N/A	31.8 1.25	24 1 ⁽⁵⁾	46.5 1.83	143.5 5.65	145.5 5.73	94.0 3.70	100.3 3.95	3.0 0.12	140.5 5.53	46.3 102
QMFY22J407S ⁽⁵⁾	4 7/16 in.																	
QMFY22J408S ⁽⁵⁾	4 1/2 in.																	
QMFY22J115S ⁽⁵⁾	115 mm																	
QMFY26J125S ⁽⁵⁾	125 mm																	
QMFY26J415S ⁽⁵⁾	4 15/16 in.																	
QMFY26J500S ⁽⁵⁾	5 in.	22226	355.6 14.00 ⁽⁵⁾	175.0 6.89	284.2 11.19	177.8 7.00 ⁽⁵⁾	419.1 16.50	N/A	38.1 1.50	24 1 1/8 ⁽⁵⁾	58.7 2.31	170.2 6.70	172.2 6.78	94.7 3.73	138.4 5.45	16.8 0.66	153.4 6.04	52.2 115
QMFY26J130S ⁽⁵⁾	130 mm																	

⁽¹⁾Pilot tolerance: +0/-0.05 mm (+0/-0.002 in.).

⁽²⁾Add (p) to the end of the housing designation in the part number to order with pilot using G dimension.

⁽³⁾Piloted flange blocks will be quoted (price and delivery) upon request. For optional spigot on flange side, insert the letter P as seen in the following example: QMFP**J***S.

⁽⁴⁾Three-bolt housing.

⁽⁵⁾Six-bolt housing.

NOTE: Housings also are available with a 3/16 in. machined pilot. Please contact your Timken engineer for more information.

QMFX 5000 SERIES SQUARE FLANGE BLOCKS

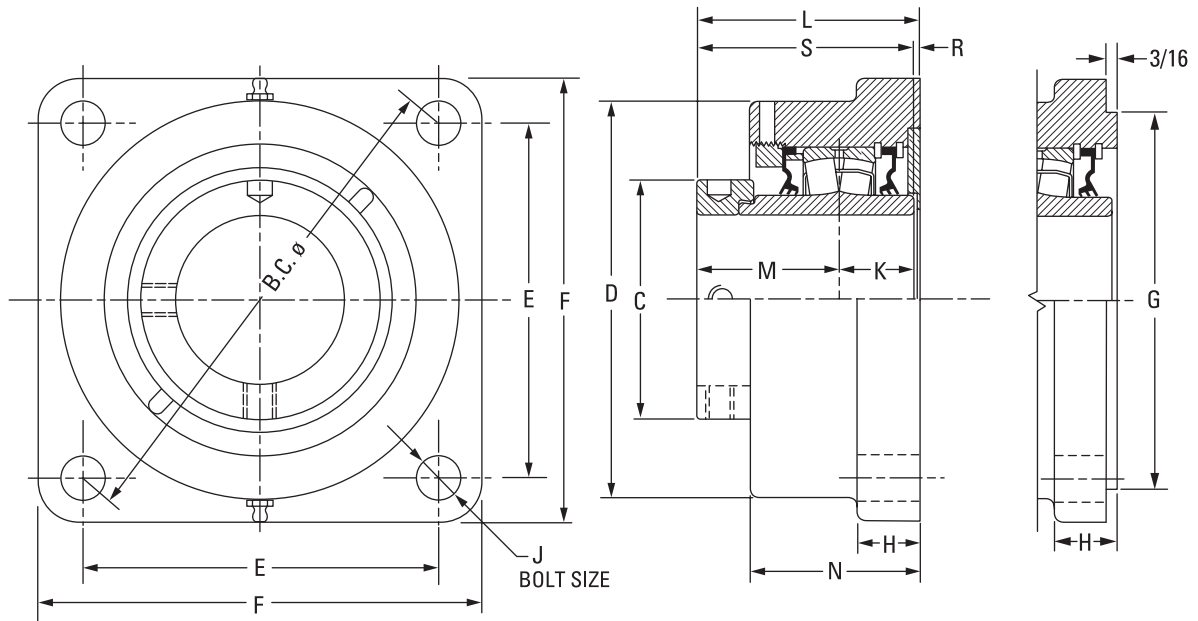

Bearing Part No.	Shaft Dia.	Bearing No.	B.C.	C	D	E	F	G ⁽¹⁾⁽²⁾⁽³⁾	H	J	K	L _{FIX}	L _{EXP}	M	N	R	S	Wt.																	
	mm in.		mm in.	mm in.	mm in.	mm in.	mm in.	mm in.	mm in.	mm in.	mm in.	mm in.	mm in.	mm in.	mm in.	mm in.	mm in.	kg lbs.																	
QMFX08J035S	35 mm	22208	133.6	59.9	93.7	94.5	117.6	90.50	22.1	12	25.4	72.9	74.9	44.5	57.2	3.0	69.9	4.5																	
QMFX08J107S	1 7/16 in.		5.26	2.36	3.69	3.72	4.63	3.563	0.88	1/2	1.00	2.87	2.95	1.75	2.25	0.12	2.75	10																	
QMFX08J108S	1 1/2 in.	22208	139.7	59.9	108.0	98.8	130.3	103.20	22.1	12	25.4	73.7	75.7	44.5	59.4	3.81	69.9	4.5																	
			5.50	2.36	4.25	3.89	5.13	4.063	0.88	1/2	1.00	2.90	2.98	1.75	2.34	0.15	2.75	10																	
QMFX09J040S	40 mm	22209	139.7	66.8	108.0	98.8	130.3	103.20	22.1	12	25.1	79.5	81.5	47.8	63.5	6.4	72.9	5.0																	
QMFX09J111S	1 11/16 in.																		5.50	2.63	4.25	3.89	5.13	4.063	0.88	1/2	0.99	3.13	3.21	1.88	2.50	0.25	2.87	11	
QMFX09J112S	1 3/4 in.																																		
QMFX09J045S	45 mm																																		
QMFX10J115S	1 15/16 in.	22210	146.1	70.1	120.7	103.1	134.9	111.13	22.1	12	24.9	80.8	82.8	48.0	65.0	7.9	72.9	5.0																	
QMFX10J200S	2 in.																		5.75	2.76	4.75	4.06	5.31	4.375	0.88	1/2	0.98	3.18	3.26	1.89	2.56	0.31	2.87	11	
QMFX10J050S	50 mm																																		
QMFX11J203S	2 3/16 in.	22211	161.5	75.9	130.3	114.3	149.4	127.00	25.4	16	28.7	83.1	85.1	50.5	66.8	3.3	79.2	5.0																	
QMFX11J204S	2 1/4 in.																		6.36	2.99	5.13	4.50	5.88	5.000	1.00	5/8	1.13	3.27	3.35	1.99	2.63	0.13	3.12	11	
QMFX11J055S	55 mm																																		
QMFX13J060S	60 mm	22213	180.8	91.9	146.1	127.8	157.2	138.13	25.4	16	31.5	89.2	91.2	54.1	72.4	3.0	85.6	6.4																	
QMFX13J207S	2 7/16 in.																		7.12	3.62	5.75	5.03	6.19	5.438	1.00	5/8	1.24	3.51	3.59	2.13	2.85	0.12	3.37	14	
QMFX13J208S	2 1/2 in.																																		
QMFX13J065S	65 mm																																		
QMFX15J211S	2 11/16 in.	22215	215.9	102.1	168.9	152.7	189.0	160.35	26.9	20	31.8	96.0	98.0	60.2	76.2	4.1	91.9	7.7																	
QMFX15J212S	2 3/4 in.																		8.50	4.02	6.65	6.01	7.44	6.313	1.06	3/4	1.25	3.78	3.86	2.37	3.00	0.16	3.62	17	
QMFX15J070S	70 mm																																		
QMFX15J215S	2 15/16 in.																																		
QMFX15J300S	3 in.																																		
QMFX15J075S	75 mm																																		

⁽¹⁾Pilot tolerance: +0/-0.05 mm (+0/-0.002 in.).

⁽²⁾Add (p) to the end of the housing designation in the part number to order with pilot using G dimension.

⁽³⁾Piloted flange blocks will be quoted (price and delivery) upon request. For optional spigot on flange side, insert the letter P as seen in the following example: QMFP**J***S.

⁽⁴⁾Six-bolt round housing.

Continued on next page.

SPHERICAL ROLLER BEARING SOLID-BLOCK HOUSED UNITS

EC SERIES • QMFX 5000 SERIES SQUARE FLANGE BLOCKS

QMFX 5000 SERIES SQUARE FLANGE BLOCKS – continued

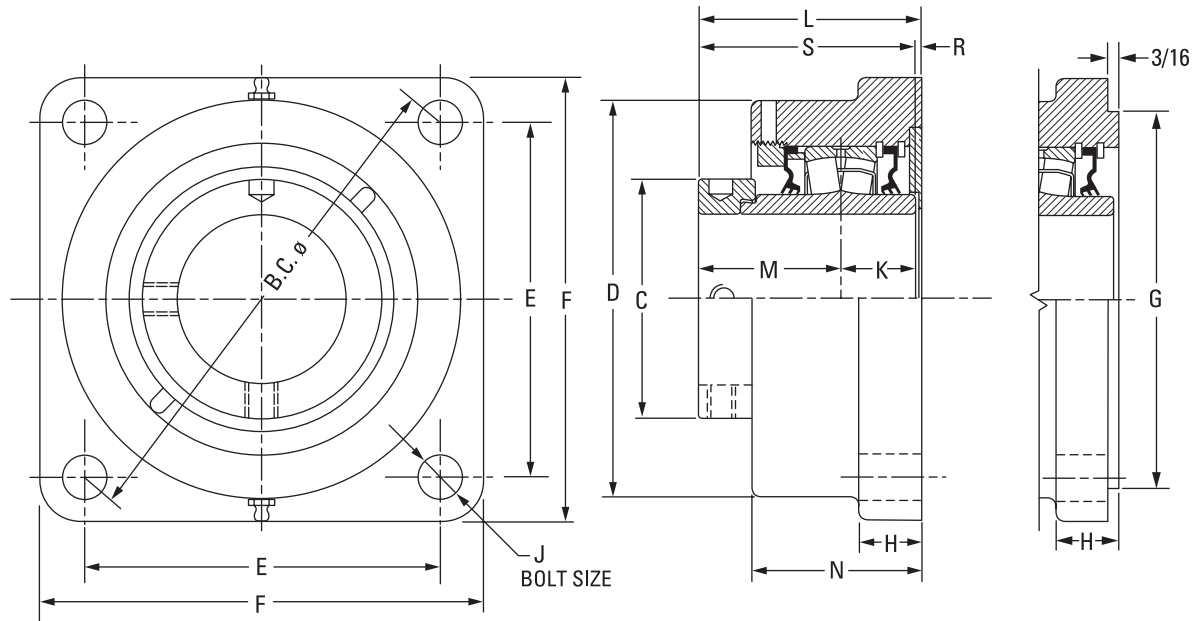

Continued from previous page.

Bearing Part No.	Shaft Dia.	Bearing No.	B.C.	C	D	E	F	G ⁽¹⁾⁽²⁾⁽³⁾	H	J	K	L _{FIX}	L _{EXP}	M	N	R	S	Wt.
	mm in.		mm in.	mm in.	mm in.	mm in.	mm in.	mm in.	mm in.	mm in.	mm in.	mm in.	mm in.	mm in.	mm in.	mm in.	mm in.	kg lbs.
QMFX18J303S	3 3/16 in.	22218	241.3 9.50	120.9 4.76	193.8 7.63	170.7 6.72	212.9 8.38	187.33 7.375	33.3 1.31	20 3/4	36.6 1.44	107.2 4.22	109.2 4.30	65.8 2.59	84.1 3.31	4.8 0.19	102.4 4.03	10.4 23
QMFX18J304S	3 1/4 in.																	
QMFX18J080S	80 mm																	
QMFX18J085S	85 mm																	
QMFX18J307S	3 7/16 in.																	
QMFX18J308S	3 1/2 in.																	
QMFX18J090S	90 mm	22220	298.5 11.75	152.4 6.00	215.9 8.50	211.1 8.31	268.2 10.56	225.43 8.875	38.1 1.50	24 7/8	41.4 1.63	126.0 4.96	128.0 5.04	75.2 2.96	103.1 4.06	9.4 0.37	116.8 4.60	15.9 35
QMFX20J311S	3 11/16 in.																	
QMFX20J312S	3 3/4 in.																	
QMFX20J315S	3 15/16 in.																	
QMFX20J400S	4 in.																	
QMFX20J100S	100 mm																	
QMFX22J110S ⁽⁴⁾	110 mm	22222	327.2 12.88 ⁽¹⁾	160.0 6.30	256.5 10.10	163.6 6.44 ⁽¹⁾	384.3 15.13	263.53 10.375	31.8 1.25	24 1 ⁽¹⁾	46.5 1.83	143.8 5.66	145.8 5.74	94.0 3.70	106.9 4.21	3.3 0.13	140.5 5.53	46.3 102
QMFX22J407S ⁽⁴⁾	4 7/16 in.																	
QMFX22J408S ⁽⁴⁾	4 1/2 in.																	
QMFX22J115S ⁽⁴⁾	115 mm																	
QMFX26J125S ⁽⁴⁾	125 mm	22226	355.6 14.00 ⁽¹⁾	175.0 6.89	284.2 11.19	177.8 7.00 ⁽¹⁾	419.1 16.50	284.18 11.188	38.1 1.50	24 1 1/8 ⁽¹⁾	58.7 2.31	172.2 6.78	174.2 6.86	94.7 3.73	135.1 5.32	17.3 0.68	153.4 6.04	52.2 115
QMFX26J415S ⁽⁴⁾	4 15/16 in.																	
QMFX26J500S ⁽⁴⁾	5 in.																	
QMFX26J130S ⁽⁴⁾	130 mm																	

⁽¹⁾Pilot tolerance: +0/-0.05 mm (+0/-0.002 in.).

⁽²⁾Add (p) to the end of the housing designation in the part number to order with pilot using G dimension.

⁽³⁾Piloted flange blocks will be quoted (price and delivery) upon request. For optional spigot on flange side, insert the letter P as seen in the following example: QMFP**J***S.

⁽⁴⁾Six-bolt round housing.

QMTU TAKE-UP BLOCKS

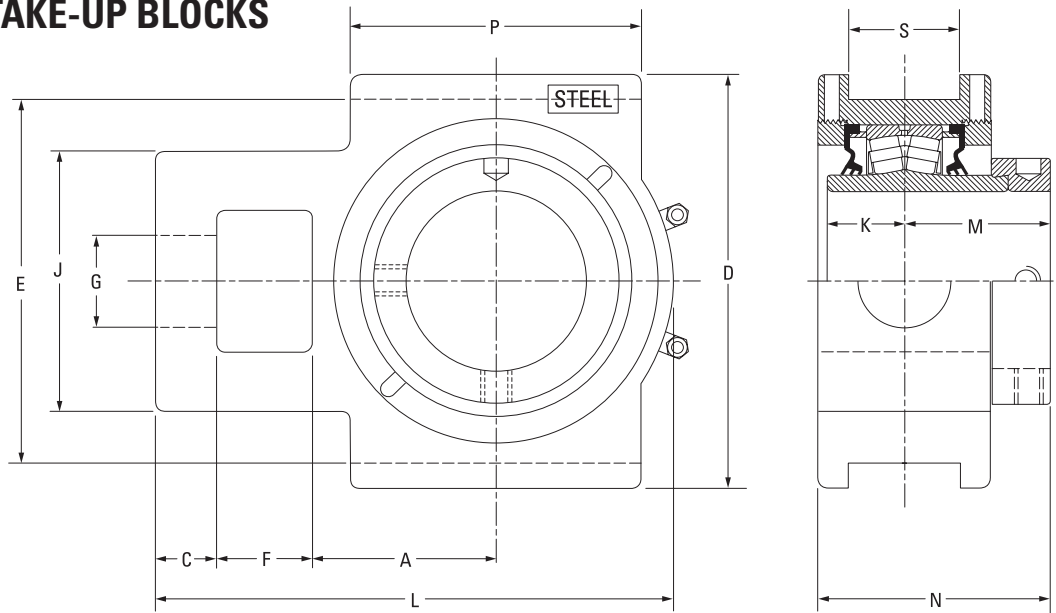

Bearing Part No.	Shaft Dia.	Bearing No.	A	C	D	E	F	G	J	K	L	M	N	P	S	Wt.
	mm in.		mm in.	mm in.	mm in.	mm in.	mm in.	mm in.	mm in.	mm in.	mm in.	mm in.	mm in.	mm in.	mm in.	kg lbs.
QMTU10J115S	1 15/16 in.	22210	54.1	19.1	120.7	101.6	26.9	26.9	73.2	24.9	153.4	48.0	76.7	88.9	17.5	7.7
QMTU10J200S	2 in.		2.13	0.75	4.75	4.00	1.06	1.06	2.88	0.98	6.04	1.89	3.02	3.50	0.69	17
QMTU10J050S	50 mm															
QMTU11J203S	2 3/4 in.	22211	60.5	19.1	133.4	114.3	30.2	30.2	88.9	28.7	167.9	50.5	82.8	95.3	20.6	9.5
QMTU11J204S	2 1/4 in.		2.38	0.75	5.25	4.50	1.19	1.19	3.50	1.13	6.61	1.99	3.26	3.75	0.81	21
QMTU11J055S	55 mm															
QMTU13J060S	60 mm	22213	69.9	22.4	149.4	130.3	33.3	33.3	95.3	31.5	193.8	54.1	90.7	120.7	26.9	12.2
QMTU13J207S	2 7/16 in.		2.75	0.88	5.88	5.13	1.31	1.31	3.75	1.24	7.63	2.13	3.57	4.75	1.06	27
QMTU13J208S	2 1/2 in.															
QMTU13J065S	65 mm	22215	76.2	25.4	171.5	150.9	39.6	39.6	108.0	31.8	219.7	60.2	97.0	120.7	46.0	15.9
QMTU15J211S	2 11/16 in.		3.00	1.00	6.75	5.94	1.56	1.56	4.25	1.25	8.65	2.37	3.82	4.75	1.81	35
QMTU15J212S	2 3/4 in.															
QMTU15J070S	70 mm	22218	92.2	25.4	193.8	173.0	46.0	47.8	124.0	36.6	257.0	65.8	106.4	158.8	46.0	20.0
QMTU18J303S	3 3/16 in.		3.63	1.00	7.63	6.81	1.81	1.88	4.88	1.44	10.12	2.59	4.19	6.25	1.81	44
QMTU18J304S	3 1/4 in.															
QMTU18J080S	80 mm	22220	104.9	28.7	239.8	219.2	54.1	52.3	143.0	41.4	296.9	75.4	120.4	177.8	52.3	26.3
QMTU18J085S	85 mm		4.13	1.13	9.44	8.63	2.13	2.06	5.63	1.63	11.69	2.97	4.74	7.00	2.06	58
QMTU18J307S	3 7/16 in.															
QMTU18J308S	3 1/2 in.	22222	128.5	38.1	263.7	241.3	54.1	54.1	162.1	46.5	341.4	94.0	143.8	199.9	52.3	36.4
QMTU18J090S	90 mm		5.06	1.50	10.38	9.50	2.13	2.13	6.38	1.83	13.44	3.70	5.66	7.87	2.06	80
QMTU20J311S	3 11/16 in.															
QMTU20J312S	3 3/4 in.	22226	134.9	63.5	285.8	260.4	63.5	60.5	177.8	58.7	396.7	94.7	151.1	228.6	52.3	60.8
QMTU20J315S	3 15/16 in.		4.13	2.50	11.25	10.25	2.50	2.38	7.00	2.31	15.62	3.73	5.95	9.00	2.06	134
QMTU20J400S	4 in.															
QMTU20J100S	100 mm	22226	134.9	63.5	285.8	260.4	63.5	60.5	177.8	58.7	396.7	94.7	151.1	228.6	52.3	60.8
QMTU22J110S	110 mm		5.31	2.50	11.25	10.25	2.50	2.38	7.00	2.31	15.62	3.73	5.95	9.00	2.06	134
QMTU22J407S	4 7/16 in.															
QMTU22J408S	4 1/2 in.	22226	134.9	63.5	285.8	260.4	63.5	60.5	177.8	58.7	396.7	94.7	151.1	228.6	52.3	60.8
QMTU22J115S	115 mm		5.31	2.50	11.25	10.25	2.50	2.38	7.00	2.31	15.62	3.73	5.95	9.00	2.06	134
QMTU26J125S	125 mm															
QMTU26J415S	4 15/16 in.	22226	134.9	63.5	285.8	260.4	63.5	60.5	177.8	58.7	396.7	94.7	151.1	228.6	52.3	60.8
QMTU26J500S	5 in.		5.31	2.50	11.25	10.25	2.50	2.38	7.00	2.31	15.62	3.73	5.95	9.00	2.06	134
QMTU26J130S	130 mm															

NOTE: Please refer to page C-169 for take-up frames.

SPHERICAL ROLLER BEARING SOLID-BLOCK HOUSED UNITS

EC SERIES • QMMC CARTRIDGE BLOCKS

QMMC CARTRIDGE BLOCKS

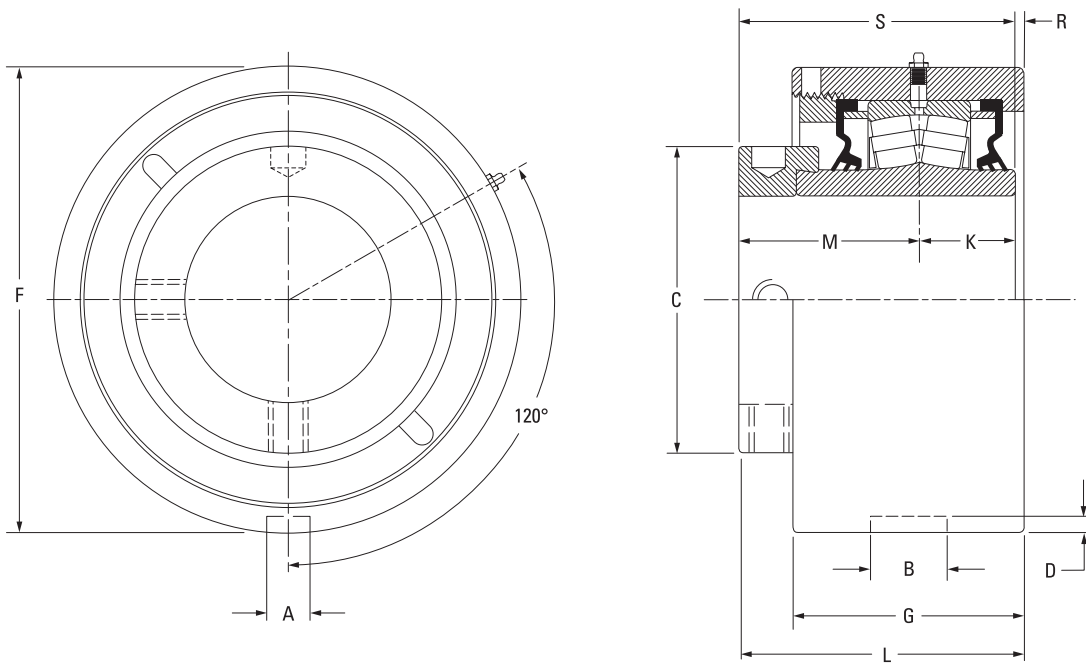

Bearing Part No.	Shaft Dia.	Bearing No.	A	B	C	D	F	G	K	L FIX	L EXP	M	R	S	Wt.	
	mm in.		mm in.	mm in.	mm in.	mm in.	mm in.	mm in.	mm in.	mm in.	mm in.	mm in.	mm in.	mm in.	kg lbs.	
QMMC10J115S	1 15/16 in.	22210	13.5	23.1	70.1	4.8	104.78 (+0/-0.05)	62.2	24.9	79.2	81.3	48.0	6.1	72.9	3.6	
QMMC10J200S	2 in.		0.53	0.91	2.76	0.19	4.125 (+0/-0.002)	2.45	0.98	3.12	3.20	1.89	0.24	2.87	8	
QMMC10J050S	50 mm															
QMMC11J203S	2 3/16 in.	22211	13.5	23.1	75.9	4.8	115.09 (+0/-0.05)	65.5	28.7	83.6	85.6	50.5	4.1	79.2	4.5	
QMMC11J204S	2 1/4 in.		0.53	0.91	2.99	0.19	4.531 (+0/-0.002)	2.58	1.13	3.29	3.37	1.99	0.16	3.12	10	
QMMC11J055S	55 mm															
QMMC13J060S ⁽¹⁾	60 mm	22213	13.5	23.1	91.9	4.8	127.00 (+0/-0.05)	69.3	31.5	85.6	87.6	54.1	0.0	85.6	5.4	
QMMC13J207S ⁽¹⁾	2 7/16 in.		0.53	0.91	3.62	0.19	5.000 (+0/-0.002)	2.73	1.24	3.37	3.45	2.13	0.00	3.37	12	
QMMC13J208S ⁽¹⁾	2 1/2 in.															
QMMC13J065S ⁽¹⁾	65 mm															
QMMC15J211S	2 11/16 in.	22215	15.0	26.2	101.9	6.4	149.225 (+0/-0.05)	79.8	31.8	100.1	102.1	60.2	8.1	91.9	8.2	
QMMC15J212S	2 3/4 in.		0.59	1.03	4.01	0.25	5.875 (+0/-0.002)	3.14	1.25	3.94	4.02	2.37	0.32	3.62	18	
QMMC15J070S	70 mm															
QMMC15J215S	2 15/16 in.															
QMMC15J300S	3 in.															
QMMC15J075S	75 mm	22218	15.0	26.9	120.9	5.8	171.45 (+0/-0.05)	87.6	36.6	109.7	111.8	65.0	7.4	102.4	11.8	
QMMC18J303S	3 3/16 in.		0.59	1.06	4.76	0.23	6.750 (+0/-0.002)	3.45	1.44	4.32	4.40	2.56	0.29	4.03	26	
QMMC18J304S	3 1/4 in.															
QMMC18J080S	80 mm															
QMMC18J085S	85 mm															
QMMC18J307S	3 7/16 in.															
QMMC18J308S	3 1/2 in.	22220	19.8	32.5	152.4	7.9	206.375 (+0/-0.05)	105.2	41.4	128.0	130.0	75.2	11.4	116.6	14.5	
QMMC18J090S	90 mm		0.78	1.28	6.00	0.31	8.125 (+0/-0.002)	4.14	1.63	5.039	5.12	2.96	0.45	4.59	32	
QMMC20J311S	3 11/16 in.															
QMMC20J312S	3 3/4 in.															
QMMC20J315S	3 15/16 in.															
QMMC20J400S	4 in.															
QMMC20J100S	100 mm															

⁽¹⁾The grub screw is located in the external housing nut to secure to the housing.

Continued on next page.

SPHERICAL ROLLER BEARING SOLID-BLOCK HOUSED UNITS

EC SERIES • QMMC CARTRIDGE BLOCKS

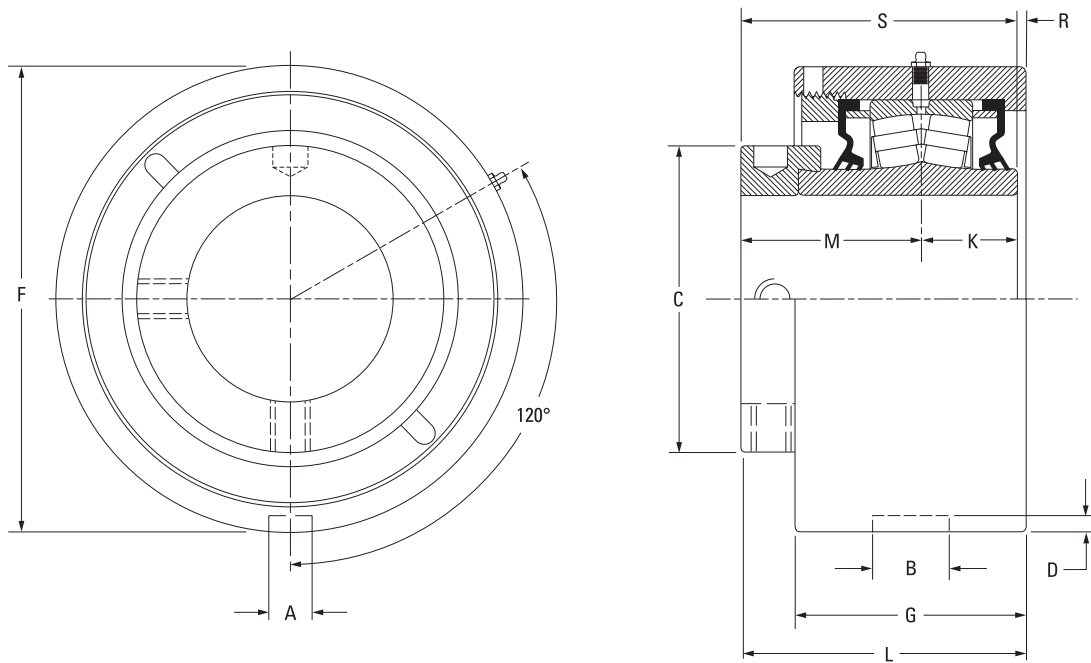

Continued from previous page.

Bearing Part No.	Shaft Dia.	Bearing No.	A	B	C	D	F	G	K	L FIX	L EXP	M	R	S	Wt.	
	mm in.		mm in.	mm in.	mm in.	mm in.	mm in.	mm in.	mm in.	mm in.	mm in.	mm in.	mm in.	mm in.	kg lbs.	
QMMC22J110S	110 mm	22222	19.8 0.78	38.1 1.50	160.0 6.30	7.9 0.31	222.25	108.5 4.27	46.5 1.83	148.0 5.83	150.1 5.91	94.0 3.70	7.6 0.30	140.5 5.53	18.1 40	
QMMC22J407S	4 7/16 in.						(+0/-0.08)									8.75
QMMC22J408S	4 1/2 in.						(+0/-0.003)									
QMMC22J115S	115 mm	22226	19.8 0.78	38.1 1.50	175.0 6.89	7.9 0.31	265.13	141.7 5.58	58.7 2.31	165.4 6.51	167.4 6.59	94.7 3.73	11.9 0.47	153.4 6.04	31.8 70	
QMMC26J125S	125 mm						(+0/-0.08)									10.438
QMMC26J415S	4 15/16 in.						(+0/-0.003)									
QMMC26J500S	130 mm	23230	19.8 0.78	38.1 1.50	205.0 8.07	5.6 0.22	292.10	154.4 6.08	75.9 2.99	188.2 7.41	190.2 7.49	116.1 4.57	-3.8 -0.15	192.0 7.56	88.0 194	
QMMC30J507S	5 7/16 in.						(+0/-0.08)									11.500
QMMC30J508S	5 1/2 in.						(+0/-0.003)									
QMMC30J140S	140 mm	23230	19.8 0.78	38.1 1.50	205.0 8.07	5.6 0.22	311.15	154.4 6.08	75.9 2.99	188.2 7.41	190.2 7.49	116.1 4.57	-3.8 -0.15	192.0 7.56	87.1 192	
QMMC30J515S	5 15/16 in.						(+0/-0.08)									12.250
QMMC30J600S	6 in.						(+0/-0.003)									
QMMC30J150S	150 mm	23234	19.8 0.78	38.1 1.50	235.0 9.25	5.6 0.22	344.50	181.1 7.13	85.1 3.35	219.5 8.64	221.5 8.72	129.0 5.08	5.33 0.21	214.1 8.43	155.6 343	
QMMC34J607S	6 7/16 in.						(+0/-0.08)									13.563
QMMC34J608S	6 1/2 in.						(+0/-0.003)									
QMMC34J170S	170 mm															
QMMC34J615S	6 15/16 in.															
QMMC34J700S	7 in.															
QMMC34J180S	180 mm															

⁽¹⁾The grub screw is located in the external housing nut to secure to the housing.

QMMH HANGER BLOCKS

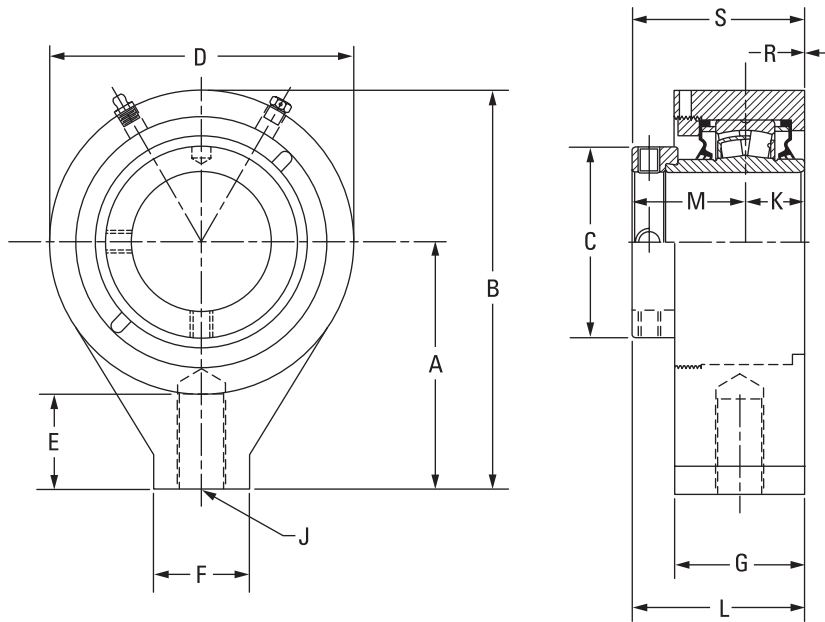

Bearing Part No.	Shaft Dia.	Bearing No.	A	B	C	D	E	F	G	J	K	L	M	R	S	Wt.
	mm in.		mm in.	mm in.	mm in.	mm in.	mm in.	mm in.	mm in.	in.	mm in.	mm in.	mm in.	mm in.	mm in.	kg lbs.
QMMH15J211S	2 11/16 in.	22215	131.8 5.19	212.9 8.38	101.9 4.01	162.1 6.38	50.8 2.00	50.8 2.00	69.9 2.75	1 -8UNC	31.8 1.25	91.9 3.62	60.2 2.37	0.0	91.9 3.62	10.0 22
QMMH15J212S	2 3/4 in.															
QMMH15J070S	70 mm															
QMMH15J215S	2 15/16 in.															
QMMH15J300S	3 in.															
QMMH15J075S	75 mm	22218	160.3 6.31	260.4 10.25	120.9 4.76	200.2 7.88	63.5 2.50	76.2 3.00	76.2 3.00	1 1/4 -7UNC	36.6 1.44	99.3 3.91	65.8 2.59	3.0	102.4 4.03	16.3 36
QMMH18J303S	3 3/16 in.															
QMMH18J304S	3 1/4 in.															
QMMH18J080S	80 mm															
QMMH18J085S	85 mm															
QMMH18J307S	3 7/16 in.															
QMMH18J308S	3 1/2 in.															
QMMH18J090S	90 mm															

TA/DV SERIES

The TA and DV series feature a 2300-series tapered adapter sleeve for increased shaft contact. This design offers the best shaft concentricity and highest capacity all the while having the ability to accommodate undersized shafting.

TA Series

TA series housed unit bearings are a direct drop-in replacement for SAF/SN split-cap housing dimensions.

DV Series

DV series housed units are a drop-in replacement for common American set screw mounted units.



Fig. C-46. TA/DV series taper adapter insert.

YOU HAVE CHOICES

For the TA and DV series, you can select from many seal options and housing styles, which are shown on page C-154.

HOUSINGS

- Two-bolt pillow blocks.
- Four-bolt pillow blocks.
- Flange blocks.
- Piloted flange cartridges.
- Cartridge blocks.

SEALS

- Labyrinth: DuPont Teflon (T).
- Triple-lip: nitrile rubber (M), urethane (O) and DuPont Viton (N).
- Double-lip: nitrile rubber (B) and DuPont Viton (C).
- Steel and urethane closed-end covers (CS).
- Steel and urethane open-end covers (CK) with:
 - DuPont Teflon (T).
 - Triple-lip seal (DR).
 - V-ring seal (VR).

SPHERICAL ROLLER BEARING SOLID-BLOCK HOUSED UNITS

TA/DV SERIES

TA/DV SERIES

	Housing Type	Primary Seals						Secondary Seals and Covers						
		M	N	O	B	C	T	Open-End Cover			Closed-End Cover	HSY Flange Cartridge Backing Plate		UFP Backing Plate
								DR	VR	T		DR		
V-Lock (Timken Exclusive Double Taper Lock)	Pillow Block	•	•	•	•	•	•	•	•	•	•	•		
	Flange Block	•	•	•	•	•	•	•	•	•	•	•		
	Piloted Flange Cartridge	•	•	•	•	•	•	•	•	•	•	•		
	Take-Up Block	•	•	•	•	•	•	•	•	•	•	•		
	Cartridge Block	•	•	•	•	•	•	•	•	•	•	•		
CL Series (Set Screw Lock)	Pillow Block	•	•	•	•	•	•	•	•	•	•	•		
	Flange Block	•	•	•	•	•	•	•	•	•	•	•		•
	Piloted Flange Cartridge	•	•	•	•	•	•	•	•	•	•	•	•	
	Take-Up Block	•	•	•	•	•	•	•	•	•	•	•		
	Cartridge Block	•	•	•	•	•	•	•	•	•	•	•		
	Hangar Block	•	•	•	•	•	•	•	•	•	•	•		
EC Series (Eccentric Lock)	Pillow Block	•	•	•	•	•	•	•	•	•	•	•		
	Flange Block	•	•	•	•	•	•	•	•	•	•	•		•
	Piloted Flange Cartridge	•	•	•	•	•	•	•	•	•	•	•	•	
	Take-Up Block	•	•	•	•	•	•	•	•	•	•	•		
	Cartridge Block	•	•	•	•	•	•	•	•	•	•	•		
	Hangar Block	•	•	•	•	•	•	•	•	•	•	•		
TA Series (Tapered Adapter Lock)	Pillow Block	•	•	•	•	•	•	•	•	•	•	•		
	Flange Block	•	•	•	•	•	•	•	•	•	•	•		
	Piloted Flange Cartridge	•	•	•	•	•	•	•	•	•	•	•		
	Cartridge Block	•	•	•	•	•	•	•	•	•	•	•		
DV Series (Tapered Adapter Lock)	Pillow Block	•	•	•	•	•	•	•	•	•	•	•		
	Flange Block	•	•	•	•	•	•	•	•	•	•	•		
	Piloted Flange Cartridge	•	•	•	•	•	•	•	•	•	•	•		

DVP TWO-BOLT PILLOW BLOCKS

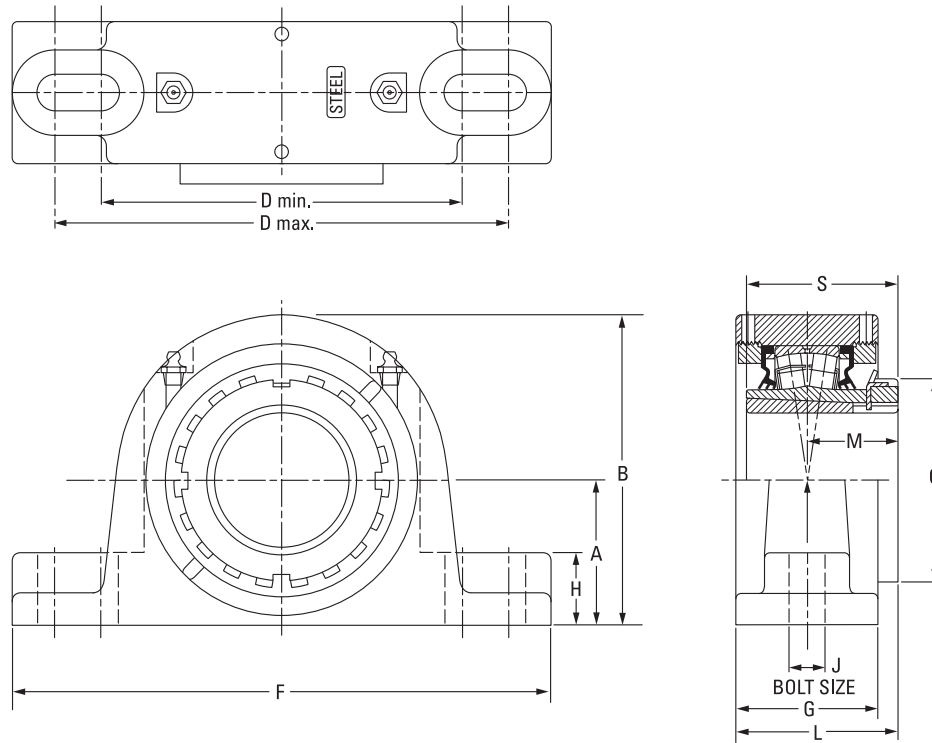

Bearing Part No.	Shaft Dia.	Bearing No.	A	B	C	D min.	D max.	F	G	H	J	L	M	S	Wt.
	mm in.		mm in.	mm in.	mm in.	mm in.	mm in.	mm in.	mm in.	mm in.	mm in.	mm in.	mm in.	mm in.	kg lbs.
DVP09K107S	1 7/16 in.	22209	47.8 1.88	98.6 3.88	65.0 2.56	119.1 4.69	152.4 6.00	174.8 6.88	53.3 2.10	25.4 1.00	12 1/2	57.4 2.26	30.7 1.21	50.3 1.98	4.5 10
DVP09K108S	1 1/2 in.	22209	54.1 2.13	104.9 4.13	65.0 2.56	119.1 4.69	165.1 6.50	200.2 7.88	53.3 2.10	25.4 1.00	12 1/2	57.4 2.26	30.7 1.21	50.3 1.98	4.5 10
DVP09K040S	40 mm														
DVP10K111S	1 11/16 in.	22210	54.1 2.13	114.3 4.50	70.1 2.76	144.8 5.70	165.1 6.50	200.2 7.88	54.9 2.16	31.8 1.25	12 1/2	61.0 2.40	33.5 1.32	55.1 2.17	5.0 11
DVP10K112S	1 3/4 in.	22210	57.2 2.25	117.3 4.62	70.1 2.76	158.8 6.25	180.8 7.12	225.6 8.88	54.9 2.16	31.8 1.25	16 5/8	61.0 2.40	33.5 1.32	55.1 2.17	5.0 11
DVP10K045S	45 mm														
DVP11K115S	1 15/16 in.	22211	57.2 2.25	123.4 4.86	74.9 2.95	152.4 6.00	181.1 7.13	225.6 8.88	61.7 2.43	31.8 1.25	16 5/8	66.5 2.62	35.6 1.40	58.9 2.32	5.9 13
DVP11K200S	2 in.														
DVP11K050S	50 mm														
DVP13K203S	2 3/16 in.	22213	63.5 2.50	138.9 5.47	85.1 3.35	165.1 6.50	200.0 7.87	244.6 9.63	70.6 2.78	32.8 1.29	16 5/8	74.9 2.95	39.6 1.56	65.0 2.56	9.1 20
DVP13K204S	2 1/4 in.														
DVP13K060S	60 mm														
DVP15K207S	2 7/16 in.	22215	69.9 2.75	149.9 5.90	98.0 3.86	174.8 6.88	219.2 8.63	260.4 10.25	68.6 2.70	35.1 1.38	16 5/8	78.2 3.08	43.9 1.73	73.4 2.89	11.3 25
DVP15K208S	2 1/2 in.														
DVP15K065S	65 mm														
DVP17K215S	2 15/16 in.	22217	82.6 3.25	173.2 6.82	110.0 4.33	200.2 7.88	244.3 9.62	295.4 11.63	76.2 3.00	35.1 1.38	20 3/4	88.1 3.47	49.8 1.96	82.0 3.23	14.5 32
DVP17K300S	3 in.														
DVP17K075S	75 mm														
DVP20K307S	3 7/16 in.	22220	95.3 3.75	202.7 7.98	130.0 5.12	238.3 9.38	285.8 11.25	342.9 13.50	85.9 3.38	47.8 1.88	24 7/8	101.3 3.99	58.4 2.30	97.0 3.82	25.9 57
DVP20K308S	3 1/2 in.														
DVP20K090S	90 mm														
DVP22K315S	3 15/16 in.	22222	108.0 4.25	223.5 8.80	145.0 5.71	255.5 10.06	317.5 12.50	362.0 14.25	100.6 3.96	38.1 1.50	24 1	113.3 4.46	63.0 2.48	104.9 4.13	30.4 67
DVP22K400S	4 in.														
DVP22K100S	100 mm														

SPHERICAL ROLLER BEARING SOLID-BLOCK HOUSED UNITS

TA/DV SERIES • TAPA SAF-STYLE TWO-BOLT PILLOW BLOCKS

TAPA SAF-STYLE TWO-BOLT PILLOW BLOCKS

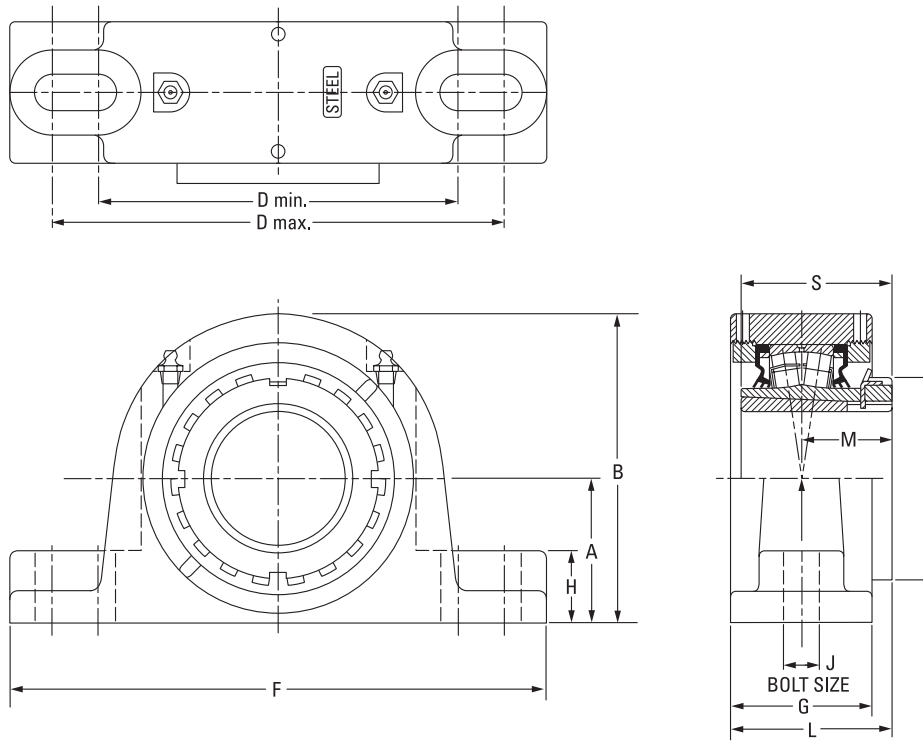

Bearing Part No.	Shaft Dia.	Bearing No.	A	B	C	D min.	D max.	F	G	H	J	L	M	S	Wt.
	mm in.		mm in.	mm in.	mm in.	mm in.	mm in.	mm in.	mm in.	mm in.	mm in.	mm in.	mm in.	mm in.	kg lbs.
TAPA09K107S	1 7/16 in.	22209	57.2	108.0	65.0	158.8	177.8	209.6	53.3	29.0	12	57.4	30.7	50.3	4.5
TAPA09K108S	1 1/2 in.		2.25	4.25	2.56	6.25	7.00	8.25	2.10	1.14	1/2	2.26	1.21	1.98	10
TAPA09K040S	40 mm														
TAPA10K111S	1 11/16 in.	22210	63.5	123.7	70.1	165.1	177.8	209.6	54.9	31.8	12	61.0	33.5	55.1	5.9
TAPA10K112S	1 3/4 in.		2.50	4.87	2.76	6.50	7.00	8.25	2.16	1.25	1/2	2.40	1.32	2.17	13
TAPA10K045S	45 mm														
TAPA11K115S	1 15/16 in.	22211	69.9	135.4	74.9	165.1	221.0	251.0	60.5	31.8	16	65.8	35.6	58.9	7.7
TAPA11K200S	2 in.		2.75	5.33	2.95	6.50	8.70	9.88	2.38	1.25	5/8	2.59	1.40	2.32	17
TAPA11K050S	50 mm														
TAPA13K203S	2 3/16 in.	22213	76.2	151.1	85.1	182.9	233.7	261.9	68.6	31.2	16	73.9	39.6	65.0	10.4
TAPA13K204S	2 1/4 in.		3.00	5.95	3.35	7.20	9.20	10.31	2.70	1.23	5/8	2.91	1.56	2.56	23
TAPA13K060S	60 mm														
TAPA15K207S	2 7/16 in.	22215	82.6	163.3	98.0	200.2	244.6	276.4	68.6	31.8	16	78.2	43.9	72.9	12.2
TAPA15K208S	2 1/2 in.		3.25	6.43	3.86	7.88	9.63	10.88	2.70	1.25	5/8	3.08	1.73	2.87	27
TAPA15K065S	65 mm														
TAPA17K215S	2 15/16 in.	22217	95.3	185.9	110.0	241.3	279.4	320.8	76.2	33.8	20	88.1	49.8	82.0	15.0
TAPA17K300S	3 in.		3.75	7.32	4.33	9.50	11.00	12.63	3.00	1.33	3/4	3.47	1.96	3.23	33
TAPA17K075S	75 mm														
TAPA20K307S	3 7/16 in.	22220	114.3	219.2	130.0	276.4	327.2	368.3	86.9	41.4	24	102.4	58.4	97.0	29.5
TAPA20K308S	3 1/2 in.		4.50	8.63	5.12	10.88	12.88	14.50	3.42	1.63	7/8	4.03	2.30	3.82	65
TAPA20K090S	90 mm														
TAPA22K315S	3 15/16 in.	22222	125.5	240.5	145.0	317.5	368.3	406.4	100.6	50.8	24	113.5	63.0	104.9	38.1
TAPA22K400S	4 in.		4.94	9.47	5.71	12.50	14.50	16.00	3.96	2.00	7/8	4.47	2.48	4.13	84
TAPA22K100S	100 mm														
TAPA26K407S	4 7/16 in.	22226	152.4	284.0	165.1	362.0	400.1	444.5	128.0	51.8	24	135.9	71.9	120.9	61.7
TAPA26K408S	4 1/2 in.		6.00	11.18	6.50	14.25	15.75	17.50	5.04	2.04	1	5.35	2.83	4.76	136
TAPA26K115S	115 mm														
TAPA28K415S	4 15/16 in.	22228	152.4	290.8	180.1	384.3	447.8	499.9	85.6	51.8	30	120.4	77.5	131.1	61.8
TAPA28K500S	5 in.		6.00	11.45	7.09	15.13	17.63	19.68	3.37	2.04	1 1/4	4.74	3.05	5.16	136
TAPA28K125S	125 mm														

TAPN SN-STYLE TWO-BOLT PILLOW BLOCKS

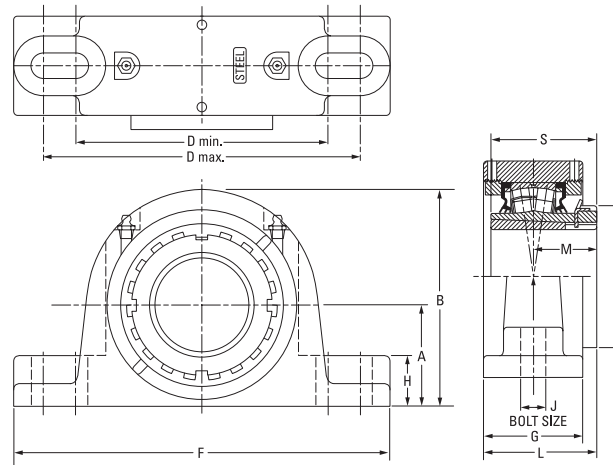

Bearing Part No.	Shaft Dia.	Bearing No.	A	B	C	D min.	D max.	F	G	H	J	L	M	S	Wt.
	mm in.		mm in.	mm in.	mm in.	mm in.	mm in.	mm in.	mm in.	mm in.	mm in.	mm in.	mm in.	mm in.	kg lbs.
TAPN09K107S	1 7/16 in.	22209	60.0	108.0	65.0	158.8	177.8	209.6	53.3	29.0	12	57.4	30.7	50.3	4.5
TAPN09K108S	1 1/2 in.		2.362	4.25	2.56	6.25	7.00	8.25	2.10	1.14	1/2	2.26	1.21	1.98	10
TAPN09K040S	40 mm														
TAPN10K111S	1 11/16 in.	22210	60.0	120.1	70.1	165.1	177.8	209.6	54.9	28.2	12	61.0	33.5	55.1	5.9
TAPN10K112S	1 3/4 in.		2.362	4.73	2.76	6.50	7.00	8.25	2.16	1.11	1/2	2.40	1.32	2.17	13
TAPN10K045S	45 mm														
TAPN11K115S	1 15/16 in.	22211	69.9	135.4	74.9	165.1	221.0	251.0	60.5	31.8	16	65.8	35.6	58.9	7.7
TAPN11K200S	2 in.		2.75	5.33	2.95	6.50	8.70	9.88	2.38	1.25	5/8	2.59	1.40	2.32	17
TAPN11K050S	50 mm														
TAPN12K055S	55 mm	22212	70.0	140.5	79.8	177.8	219.2	254.0	60.5	31.8	16	67.6	37.6	62.0	9.1
			2.756	5.53	3.14	7.00	8.63	10.00	2.38	1.25	5/8	2.66	1.48	2.44	20
TAPN13K203S	2 3/16 in.	22213	80.0	154.9	85.1	182.9	233.7	261.9	68.6	35.1	16	73.9	39.6	65.0	10.4
TAPN13K204S	2 1/4 in.		3.15	6.10	3.35	7.20	9.20	10.31	2.70	1.38	5/8	2.91	1.56	2.56	23
TAPN13K060S	60 mm														
TAPN15K207S	2 7/16 in.	22215	80.0	160.8	98.0	200.2	244.6	276.4	68.6	29.2	16	78.2	43.9	72.9	12.2
TAPN15K208S	2 1/2 in.		3.15	6.33	3.86	7.88	9.63	10.88	2.70	1.15	5/8	3.08	1.73	2.87	27
TAPN15K065S	65 mm														
TAPN16K211S	2 11/16 in.	22216	95.0	180.3	104.6	235.0	266.7	315.0	72.6	31.8	20	83.8	47.5	78.0	13.6
TAPN16K212S	2 3/4 in.		3.74	7.10	4.12	9.25	10.50	12.40	2.86	1.25	3/4	3.30	1.87	3.07	30
TAPN16K070S	70 mm														
TAPN17K215S	2 15/16 in.	22217	95.3	185.9	110.0	241.3	279.4	320.8	76.2	33.8	20	88.1	49.8	82.0	15.0
TAPN17K300S	3 in.		3.75	7.32	4.33	9.50	11.00	12.63	3.00	1.33	3/4	3.47	1.96	3.23	33
TAPN17K075S	75 mm														
TAPN18K080S	80 mm	22218	100.0	195.3	119.6	285.8	295.4	346.2	79.8	38.9	20	91.7	52.1	86.1	22.2
TAPN18K303S	3 3/16 in.		3.937	7.69	4.71	11.25	11.63	13.63	3.14	1.53	3/4	3.61	2.05	3.39	49
TAPN18K304S	3 1/4 in.														
TAPN19K085S	85 mm	22219	112.0	212.3	124.7	285.8	295.4	346.2	82.8	38.9	20	96.0	54.6	89.9	23.1
			4.409	8.36	4.91	11.25	11.63	13.63	3.26	1.53	3/4	3.78	2.15	3.54	51
TAPN20K307S	3 7/16 in.	22220	112.0	216.9	130.0	276.4	327.2	368.3	86.9	38.9	24	102.4	58.4	97.0	29.5
TAPN20K308S	3 1/2 in.		4.409	8.54	5.12	10.88	12.88	14.50	3.42	1.53	7/8	4.03	2.30	3.82	65
TAPN20K090S	90 mm														
TAPN22K315S	3 15/16 in.	22222	125.0	240.5	145.0	317.5	368.3	406.4	100.6	50.8	24	113.5	63.0	104.9	38.1
TAPN22K400S	4 in.		4.921	9.47	5.71	12.50	14.50	16.00	3.96	2.00	7/8	4.47	2.48	4.13	84
TAPN22K100S	100 mm														
TAPN24K403S	4 3/16 in.	22224	140.0	262.9	154.4	344.4	355.6	409.7	97.8	50.8	24	116.1	67.1	112.0	49.9
TAPN24K404S	4 1/4 in.		5.512	10.35	6.08	13.56	14.00	16.13	3.85	2.00	7/8	4.57	2.64	4.41	110
TAPN24K110S	110 mm														
TAPN26K407S	4 7/16 in.	22226	150.0	281.7	165.1	367.3	400.1	444.5	128.0	49.3	24	135.9	71.9	120.9	61.7
TAPN26K408S	4 1/2 in.		5.906	11.09	6.50	14.46	15.75	17.50	5.04	1.94	1	5.35	2.83	4.76	136
TAPN26K115S	115 mm														
TAPN28K415S	4 15/16 in.	22228	150.0	288.5	180.1	384.3	447.8	499.9	85.6	49.3	30	120.4	77.5	131.1	61.8
TAPN28K500S	5 in.		5.906	11.36	7.09	15.13	17.63	19.68	3.37	1.94	1 1/4	4.74	3.05	5.16	136
TAPN28K125S	125 mm														

TAPKT 9000 SERIES TWO-BOLT PILLOW BLOCKS

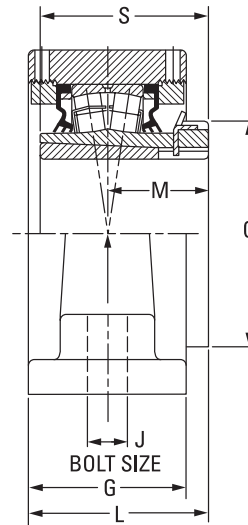
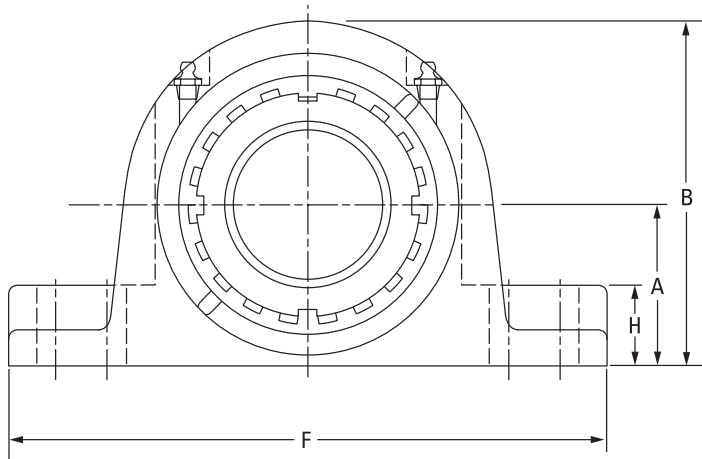
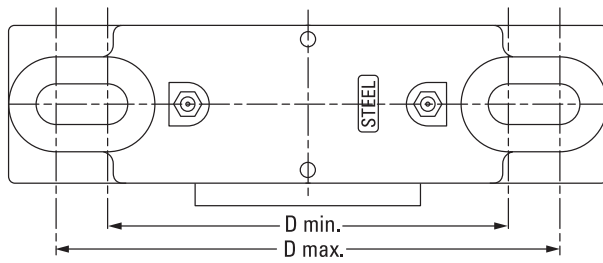

Bearing Part No.	Shaft Dia.	Bearing No.	A	B	C	D min.	D max.	F	G	H	J	L	M	S	Wt.
	mm in.		mm in.	mm in.	mm in.	mm in.	mm in.	mm in.	mm in.	mm in.	mm in.	mm in.	mm in.	mm in.	kg lbs.
TAPKT13K203S	2 3/16 in.	22213	76.2	153.7	85.1	194.6	223.0	285.8	73.7	35.1	20	76.5	36.6	65.0	10.0
TAPKT13K204S	2 1/4 in.		3.00	6.05	3.35	7.66	8.78	11.25	2.90	1.38	3/4	3.01	1.56	2.56	22
TAPKT13K060S	60 mm														
TAPKT15K207S	2 7/16 in.	22215	88.9	173.7	98.0	230.1	265.2	330.2	75.7	35.1	24	81.8	43.9	72.9	12.7
TAPKT15K208S	2 1/2 in.		3.50	6.84	3.86	9.06	10.44	13.00	2.98	1.38	7/8	3.22	1.73	2.87	28
TAPKT15K065S	65 mm														

DVPF FOUR-BOLT PILLOW BLOCKS

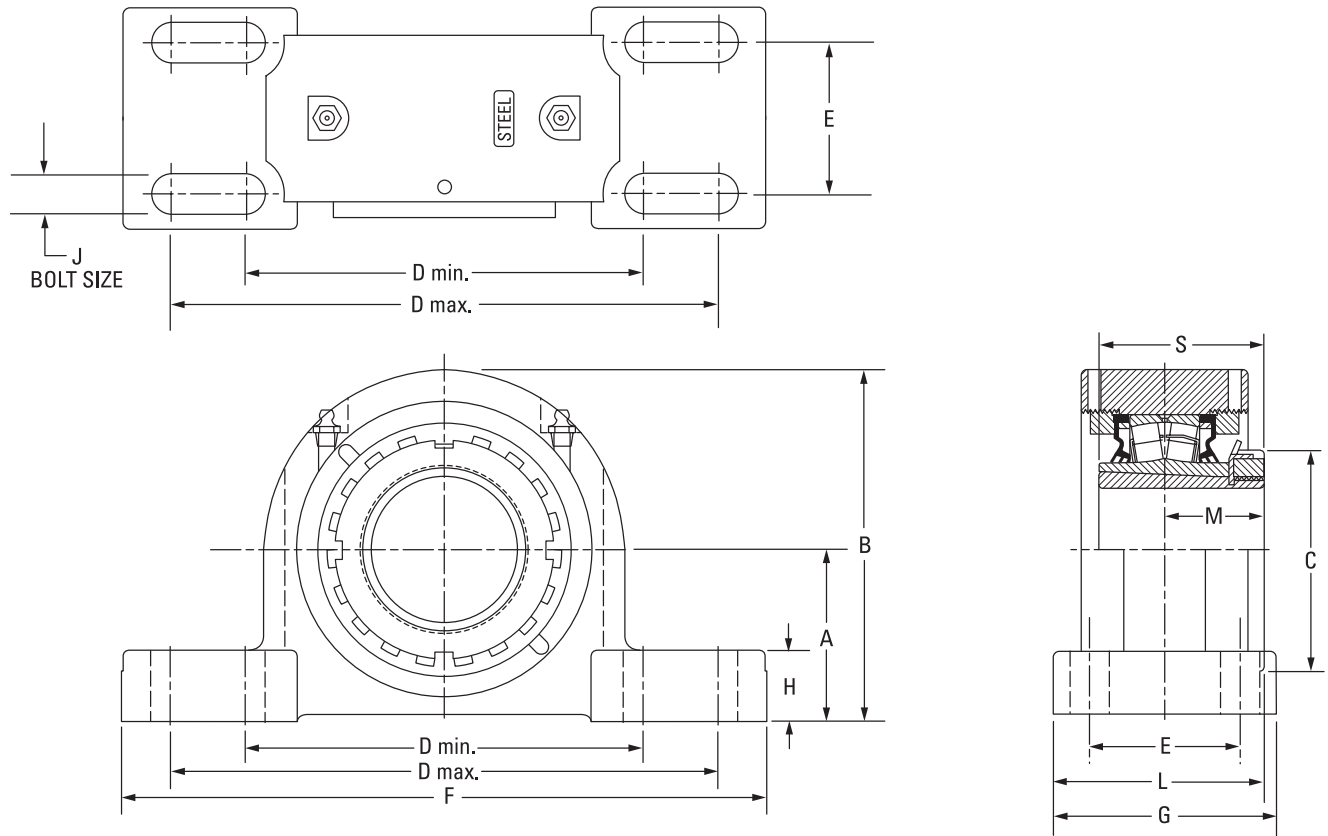

Bearing Part No.	Shaft Dia.	Bearing No.	A	B	C	D min.	D max.	E	F	G	H	J	L	M	S	Wt.
	mm in.		mm in.	mm in.	mm in.	mm in.	mm in.	mm in.	mm in.	mm in.	mm in.	mm in.	mm in.	mm in.	mm in.	kg lbs.
DVPF17K215S	2 15/16 in.	22217	82.6	172.5	110.0	193.0	231.1	47.8	265.2	79.5	32.8	16	86.6	49.8	82.0	23.1
DVPF17K300S	3 in.		3.25	6.79	4.33	7.60	9.10	1.88	10.44	3.13	1.29	5/8	3.41	1.96	3.23	51
DVPF17K075S	75 mm															
DVPF20K307S	3 7/16 in.	22220	95.3	200.2	130.0	225.6	276.4	50.8	312.4	95.3	39.6	20	101.3	58.4	97.0	31.8
DVPF20K308S	3 1/2 in.		3.75	7.88	5.12	8.88	10.88	2.00	12.30	3.75	1.56	3/4	3.99	2.30	3.82	70
DVPF20K090S	90 mm															
DVPF22K315S	3 15/16 in.	22222	108.0	223.0	145.0	276.4	339.9	57.2	378.0	109.5	35.6	20	110.7	63.0	104.9	38.6
DVPF22K400S	4 in.		4.25	8.78	5.71	10.88	13.38	2.25	14.88	4.31	1.40	3/4	4.36	2.48	4.13	85
DVPF22K100S	100 mm															
DVPF26K407S	4 7/16 in.	22226	120.7	250.7	165.1	302.3	368.3	63.5	409.7	120.7	40.1	20	123.7	71.9	120.1	62.1
DVPF26K408S	4 1/2 in.		4.75	9.87	6.50	11.90	14.50	2.50	16.13	4.75	1.58	3/4	4.87	2.83	4.73	137
DVPF26K115S	115 mm															

SPHERICAL ROLLER BEARING SOLID-BLOCK HOUSED UNITS

TA/DV SERIES • TAPK 9000 SERIES FOUR-BOLT PILLOW BLOCKS

TAPK 9000 SERIES FOUR-BOLT PILLOW BLOCKS

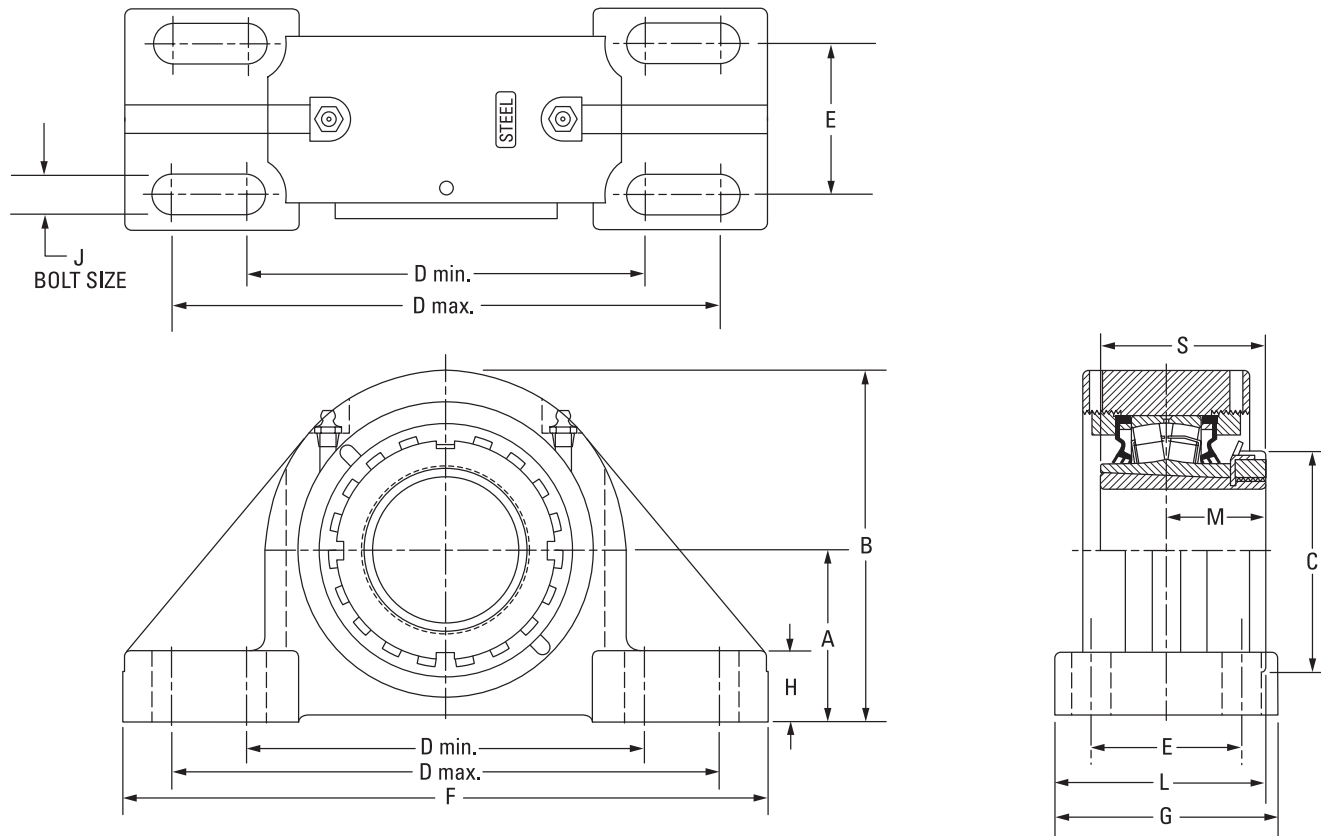

Bearing Part No.	Shaft Dia.	Bearing No.	A	B	C	D min.	D max.	E	F	G	H	J	L	M	S	Wt.
	mm in.		mm in.	mm in.	mm in.	mm in.	mm in.	mm in.	mm in.	mm in.	mm in.	mm in.	mm in.	mm in.	mm in.	kg lbs.
TAPK15K207S	2 7/16 in.	22215	88.9	173.5	98.0	230.1	265.2	69.9	330.2	108.0	39.1	20	98.0	43.9	72.9	13.2
TAPK15K208S	2 1/2 in.		3.50	6.83	3.86	9.06	10.44	2.75	13.00	4.25	1.54	3/4	3.86	1.73	2.87	29
TAPK15K065S	65 mm															
TAPK17K215S	2 15/16 in.	22217	101.6	201.2	110.0	274.6	309.6	76.2	381.0	120.7	38.1	20	110.2	49.8	82.0	16.8
TAPK17K300S	3 in.		4.00	7.92	4.33	10.81	12.19	3.00	15.00	4.75	1.50	3/4	4.34	1.96	3.23	37
TAPK17K075S	75 mm															
TAPK20K307S	3 7/16 in.	22220	127.0	239.8	130.0	317.5	355.6	88.9	425.5	139.7	41.4	24	128.3	58.4	97.0	31.8
TAPK20K308S	3 1/2 in.		5.00	9.44	5.12	12.50	14.00	3.50	16.75	5.50	1.63	7/8	5.05	2.30	3.82	70
TAPK20K090S	90 mm															
TAPK22K315S	3 15/16 in.	22222	146.1	273.8	145.0	354.1	395.2	101.6	469.9	158.8	45.7	24	138.2	63.0	104.9	39.5
TAPK22K400S	4 in.		5.75	10.78	5.71	13.94	15.56	4.00	18.50	6.25	1.80	1	5.44	2.48	4.13	87
TAPK22K100S	100 mm															
TAPK26K407S	4 7/16 in.	22226	155.6	283.2	165.1	387.4	425.5	108.0	514.4	171.5	50.8	24	157.5	71.9	120.9	61.7
TAPK26K408S	4 1/2 in.		6.125	11.15	6.50	15.25	16.75	4.25	20.25	6.75	2.00	1 1/8	6.20	2.83	4.76	136
TAPK26K115S	115 mm															

TAPH SAF-STYLE FOUR-BOLT PILLOW BLOCKS

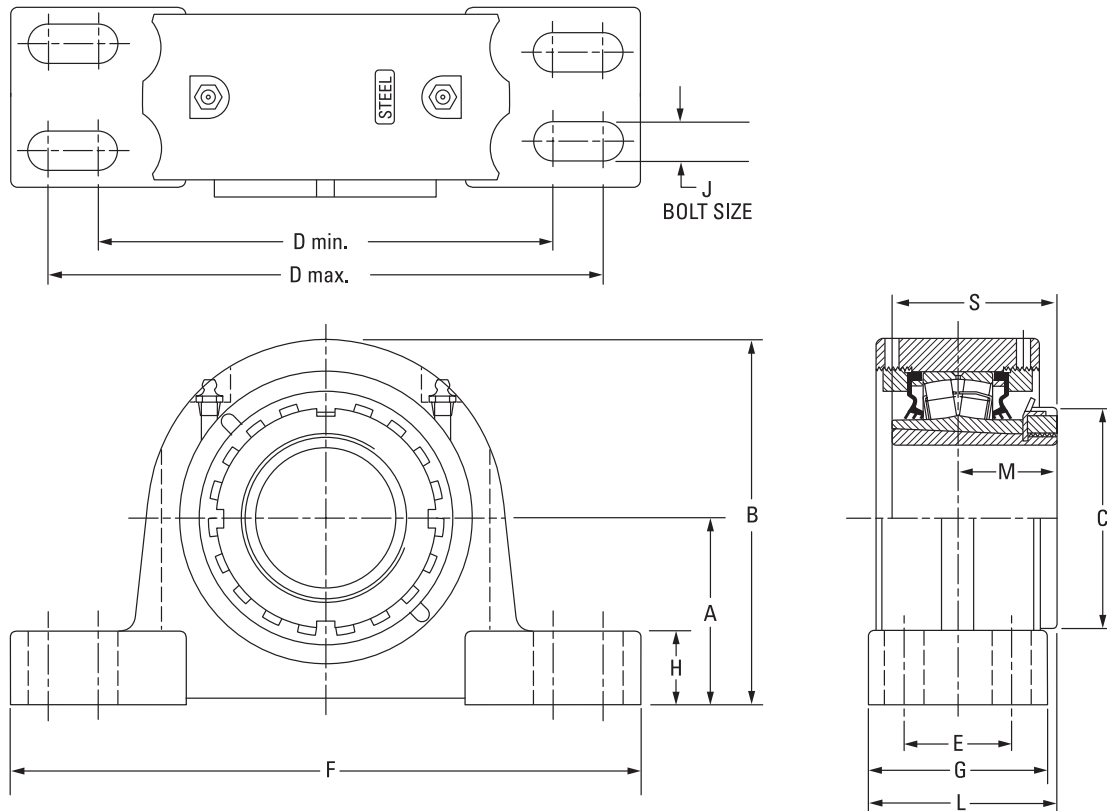

Bearing Part No.	Shaft Dia.	Bearing No.	A	B	C	D min.	D max.	E	F	G	H	J	L	M	S	Wt.
	mm in.		mm in.	mm in.	mm in.	mm in.	mm in.	mm in.	mm in.	mm in.	mm in.	mm in.	mm in.	mm in.	mm in.	kg lbs.
TAPH11K115S	1 15/16 in.	22211	69.9	134.9	74.9	182.4	217.4	39.9	251.0	68.6	31.8	16	69.9	35.6	58.9	8.6
TAPH11K200S	2 in.		2.75	5.31	2.95	7.18	8.56	1.57	9.88	2.70	1.25	5/8	2.75	1.40	2.32	19
TAPH11K050S	50 mm															
TAPH13K203S	2 3/16 in.	22213	76.2	151.1	85.1	182.4	217.4	50.8	261.9	82.6	31.2	12	81.0	39.6	65.0	11.3
TAPH13K204S	2 1/4 in.		3.00	5.95	3.35	7.18	8.56	2.00	10.31	3.25	1.23	1/2	3.19	1.56	2.56	25
TAPH13K060S	60 mm															
TAPH15K207S	2 7/16 in.	22215	82.6	162.1	98.0	201.7	246.1	47.8	276.4	79.5	32.8	12	83.6	43.9	72.9	13.2
TAPH15K208S	2 1/2 in.		3.25	6.38	3.86	7.94	9.69	1.88	10.88	3.13	1.29	1/2	3.29	1.73	2.87	29
TAPH15K065S	65 mm															
TAPH17K215S	2 15/16 in.	22217	95.3	182.9	110.0	239.8	287.3	54.1	320.8	92.2	32.0	16	96.0	49.8	82.0	16.8
TAPH17K300S	3 in.		3.75	7.20	4.33	9.44	11.31	2.13	12.63	3.63	1.26	5/8	3.78	1.96	3.23	37
TAPH17K075S	75 mm															
TAPH20K307S	3 7/16 in.	22220	114.3	216.9	130.0	276.4	339.9	60.5	381	109.5	41.9	20	113.3	58.4	97.0	31.8
TAPH20K308S	3 1/2 in.		4.50	8.54	5.12	10.88	13.38	2.38	15.00	4.31	1.65	3/4	4.46	2.30	3.82	70
TAPH20K090S	90 mm															
TAPH22K315S	3 15/16 in.	22222	125.5	238.3	145.0	301.8	368.3	69.9	406.4	120.7	45.0	20	123.4	63.0	104.9	39.5
TAPH22K400S	4 in.		4.94	9.38	5.71	11.88	14.50	2.75	16.00	4.75	1.77	3/4	4.86	2.48	4.13	87
TAPH22K100S	100 mm															
TAPH26K407S	4 7/16 in.	22226	152.4	284.0	165.1	362.0	400.1	82.6	444.5	128.0	51.8	24	135.9	71.9	120.9	61.7
TAPH26K408S	4 1/2 in.		6.00	11.18	6.50	14.25	15.75	3.25	17.50	5.04	2.04	3/4	5.35	2.83	4.76	136
TAPH26K115S	115 mm															
TAPH28K415S	4 15/16 in.	22228	152.4	290.8	180.1	406.4	435.1	85.9	500.4	128.0	51.8	24	141.5	77.5	131.1	61.8
TAPH28K500S	5 in.		6.00	11.45	7.09	16.00	17.13	3.38	19.70	5.04	2.04	1	5.57	3.05	5.16	136
TAPH28K125S	125 mm															

SPHERICAL ROLLER BEARING SOLID-BLOCK HOUSED UNITS

TA/DV SERIES • TAPG SN-STYLE FOUR-BOLT PILLOW BLOCKS

TAPG SN-STYLE FOUR-BOLT PILLOW BLOCKS

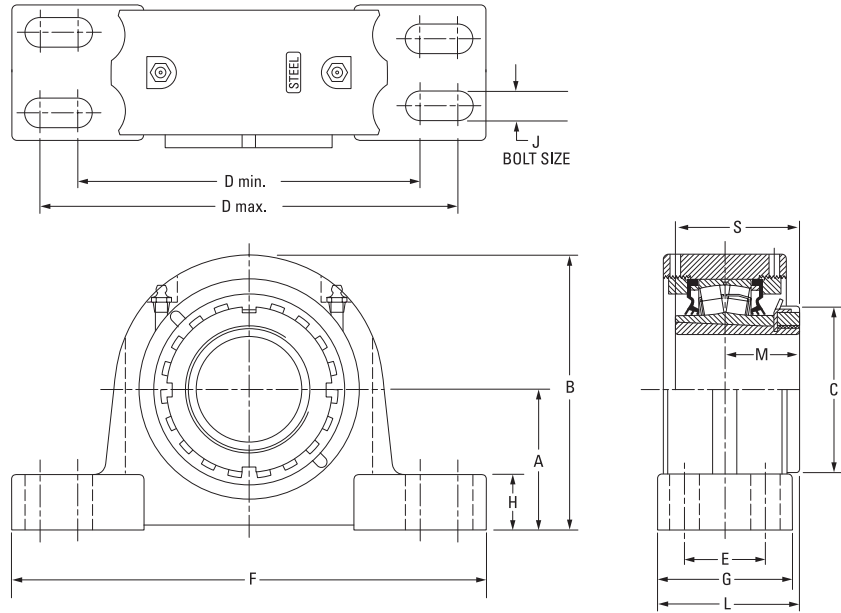

Bearing Part No.	Shaft Dia.	Bearing No.	A	B	C	D min.	D max.	E	F	G	H	J	L	M	S	Wt.
	mm in.		mm in.	mm in.	mm in.	mm in.	mm in.	mm in.	mm in.	mm in.	mm in.	mm in.	mm in.	mm in.	mm in.	kg lbs.
TAPG11K115S	1 15/16 in.	22211	69.9	134.9	74.9	182.4	217.4	39.9	251.0	68.6	31.8	16	69.9	35.6	58.9	8.6
TAPG11K200S	2 in.		2.75	5.31	2.95	7.18	8.56	1.57	9.88	2.70	1.25	5/8	2.75	1.40	2.32	19
TAPG11K050S	50 mm															
TAPG12K055S	55 mm	22212	70.0	140.5	79.8	177.8	219.2	35.1	254.0	69.9	31.8	12	72.6	37.6	62.0	9.9
			2.756	5.53	3.14	7.00	8.63	1.38	10.00	2.75	1.25	1/2	2.86	1.48	2.44	22
TAPG13K203S	2 3/16 in.	22213	80.0	154.9	85.1	182.4	217.4	48.0	261.9	82.6	35.1	16	81.0	39.6	65.0	11.3
TAPG13K204S	2 1/4 in.		3.15	6.10	3.35	7.18	8.56	1.89	10.31	3.25	1.38	5/8	3.19	1.56	2.56	25
TAPG13K060S	60 mm															
TAPG15K207S	2 7/16 in.	22215	80.0	162.1	98.0	201.7	246.1	39.6	276.4	79.5	30.2	16	83.8	43.9	72.9	13.2
TAPG15K208S	2 1/2 in.		3.15	6.38	3.86	7.94	9.69	1.56	10.88	3.13	1.19	5/8	3.30	1.73	2.87	29
TAPG15K065S	65 mm															
TAPG16K211S	2 11/16 in.	22216	95.0	180.3	104.6	235.0	266.7	50.0	315.0	89.9	31.8	16	92.5	47.5	78.0	14.9
TAPG16K212S	2 3/4 in.		3.74	7.10	4.12	9.25	10.50	1.97	12.40	3.54	1.25	5/8	3.64	1.87	3.07	33
TAPG16K070S	70 mm															
TAPG17K215S	2 15/16 in.	22217	95.0	182.9	110.0	239.8	287.3	52.3	320.8	92.2	31.8	20	96.0	49.8	82.0	16.8
TAPG17K300S	3 in.		3.74	7.20	4.33	9.44	11.31	2.06	12.63	3.63	1.25	3/4	3.78	1.96	3.23	37
TAPG17K075S	75 mm															
TAPG18K080S	80 mm	22218	100.0	195.3	119.6	282.7	298.5	50.0	344.9	100.1	39.6	16	102.1	52.1	86.1	24.5
TAPG18K303S	3 3/16 in.		3.937	7.69	4.71	11.13	11.75	1.97	13.58	3.94	1.56	5/8	4.02	2.05	3.39	54
TAPG18K304S	3 1/4 in.															
TAPG19K085S	85 mm	22219	112.0	212.3	124.7	282.7	298.5	50.0	344.9	100.1	39.6	16	104.6	54.6	89.9	25.4
			4.409	8.36	4.91	11.13	11.75	1.97	13.58	3.94	1.56	5/8	4.12	2.15	3.54	56
TAPG20K307S	3 7/16 in.	22220	112.0	214.6	130.0	276.4	339.9	60.5	381.0	109.5	39.6	20	113.3	58.4	97.0	31.8
TAPG20K308S	3 1/2 in.		4.409	8.45	5.12	10.88	13.38	2.38	15.00	4.31	1.56	3/4	4.46	2.30	3.82	70
TAPG20K090S	90 mm															
TAPG22K315S	3 15/16 in.	22222	112.0	238.3	145.0	301.8	368.3	69.9	406.4	120.7	44.5	20	123.4	63.0	104.9	39.5
TAPG22K400S	4 in.		4.921	9.38	5.71	11.88	14.50	2.75	16.00	4.75	1.75	3/4	4.86	2.48	4.13	87
TAPG22K100S	100 mm															
TAPG24K403S	4 3/16 in.	22224	140.0	262.9	154.4	342.9	355.6	70.1	410.0	120.7	50.8	16	127.5	67.1	112.0	49.9
TAPG24K404S	4 1/4 in.		5.512	10.35	6.08	13.50	14.00	2.76	16.14	4.75	2.00	5/8	5.02	2.64	4.41	110
TAPG24K110S	110 mm															
TAPG26K407S	4 7/16 in.	22226	150.0	281.7	165.1	367.28	400.1	81.0	444.5	128.0	49.3	24	135.9	71.88	120.9	61.7
TAPG26K408S	4 1/2 in.		5.906	11.09	6.50	14.46	15.75	3.19	17.50	5.04	1.94	1	5.35	2.83	4.76	136
TAPG26K115S	115 mm															
TAPG28K415S	4 15/16 in.	22228	150.0	288.4	180.1	384.3	447.8	80.0	500.4	128.0	49.3	24	141.5	77.5	131.1	61.8
TAPG28K500S	5 in.		5.906	11.36	7.09	15.13	17.63	3.15	19.70	5.04	1.94	1	5.57	3.05	5.16	136
TAPG28K125S	125 mm															

DVC PILOTED FLANGE CARTRIDGES

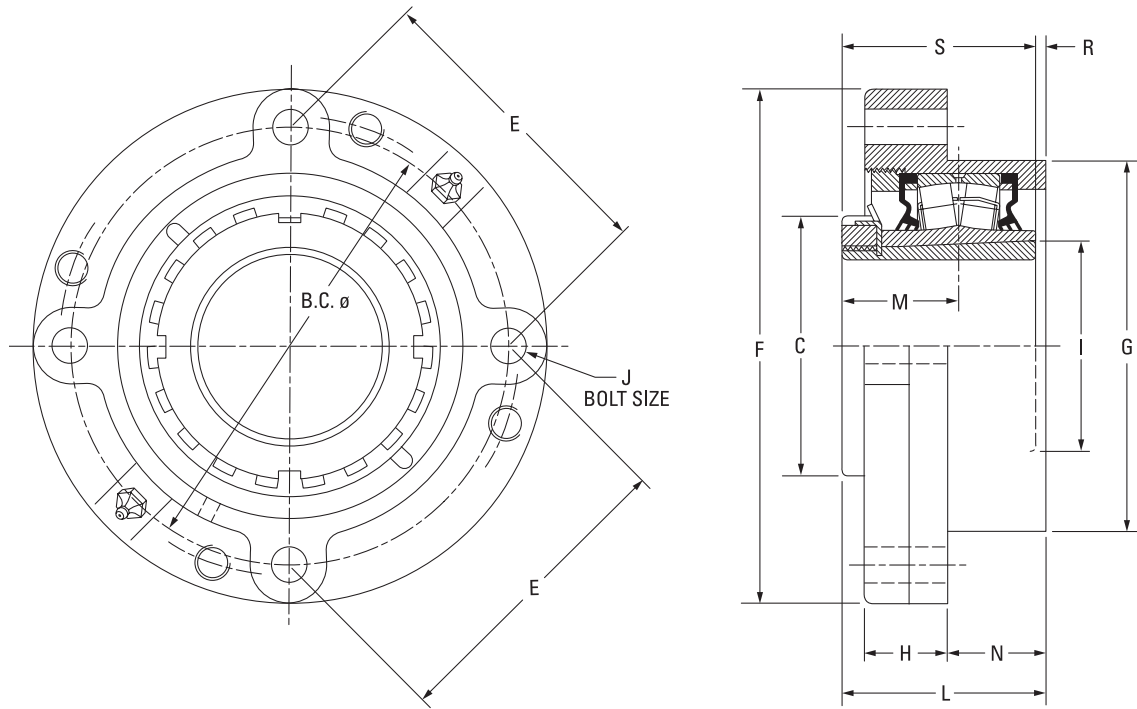

Bearing Part No.	Shaft Dia.	Bearing No.	B.C.	C	E	F	G ⁽¹⁾	H	I	J	L	M	N	R	S	Wt.
			mm in.	mm in.	mm in.	mm in.	mm in.	mm in.	mm in.	mm in.	mm in.	mm in.	mm in.	mm in.	mm in.	mm in.
DVC09K107S	1 7/16 in.	22209	111.3	65.0	78.5	133.4	92.1	26.7	48.3	10	55.4	30.7	23.9	5.1	50.3	4.1
DVC09K108S	1 1/2 in.		4.38	2.56	3.09	5.25	3.625	1.05	1.90	7/16	2.18	1.21	0.94	0.20	1.98	9
DVC09K040S	40 mm															
DVC10K111S	1 11/16 in.	22210	130.3	70.1	91.9	155.7	107.95	26.7	58.9	10	60.1	33.5	25.4	5.1	55.1	4.5
DVC10K112S	1 3/4 in.		5.13	2.76	3.62	6.13	4.250	1.05	2.32	7/16	2.37	1.32	1.00	0.20	2.17	10
DVC10K045S	45 mm															
DVC11K115S	1 15/16 in.	22211	136.7	74.9	96.5	162.1	114.3	31.5	62.2	10	63.2	35.6	25.4	4.1	58.9	5.0
DVC11K200S	2 in.		5.38	2.95	3.80	6.38	4.500	1.24	2.45	7/16	2.49	1.40	1.00	0.16	2.32	11
DVC11K050S	50 mm															
DVC13K203S	2 3/16 in.	22213	152.4	82.6	107.7	181.1	127.0	37.3	84.8	12	65.5	39.6	25.4	-2.8	65.0	7.3
DVC13K204S	2 1/4 in.		6.00	3.35	4.24	7.13	5.000	1.47	3.34	1/2	2.58	1.56	1.00	-0.11	2.56	16
DVC13K060S	60 mm															
DVC15K207S	2 7/16 in.	22215	165.1	98.0	116.8	193.8	139.7	32.3	79.0	12	69.9	43.9	31.8	3.6	72.9	8.2
DVC15K208S	2 1/2 in.		6.50	3.86	4.60	7.63	5.500	1.27	3.11	1/2	2.75	1.73	1.25	0.14	2.87	18
DVC15K065S	65 mm															
DVC17K215S	2 15/16 in.	22217	190.5	110.0	134.6	222.3	161.9	32.5	90.2	16	79.8	49.8	35.1	2.3	82.0	11.3
DVC17K300S	3 in.		7.50	4.33	5.30	8.75	6.375	1.28	3.55	5/8	3.14	1.96	1.38	0.09	3.23	25
DVC17K075S	75 mm															
DVC20K307S	3 7/16 in.	22220	219.2	130.0	154.9	260.4	187.3	41.1	106.2	20	91.9	58.4	35.1	5.1	97.0	16.8
DVC20K308S	3 1/2 in.		8.63	5.12	6.10	10.25	7.375	1.62	4.18	3/4	3.62	2.30	1.38	0.20	3.82	37
DVC20K090S	90 mm															
DVC22K315S	3 15/16 in.	22222	238.3	145.0	168.4	276.4	206.4	48.0	116.8	20	100.1	63.0	38.1	4.6	104.9	26.3
DVC22K400S	4 in.		9.38	5.71	6.63	10.88	8.125	1.89	4.60	3/4	3.94	2.48	1.50	0.18	4.13	58
DVC22K100S	100 mm															
DVC26K407S ⁽²⁾	4 7/16 in.	22226	298.5	165.1	149.4	342.9	260.4	47.0	137.9	20	116.8	71.9	48.3	4.1	120.9	34.5
DVC26K408S ⁽²⁾	4 1/2 in.		11.75 ⁽²⁾	6.50	5.88 ⁽²⁾	13.50	10.250	1.85	5.43	3/4 ⁽²⁾	4.60	2.83	1.90	0.16	4.76	76
DVC26K115S ⁽²⁾	115 mm															

⁽¹⁾Pilot tolerance: +0/-0.05 mm (+0/-0.002 in.).

⁽²⁾Six-bolt housing.

SPHERICAL ROLLER BEARING SOLID-BLOCK HOUSED UNITS

TA/DV SERIES • T AFC SQUARE PILOTED FLANGE CARTRIDGES

T AFC SQUARE PILOTED FLANGE CARTRIDGES

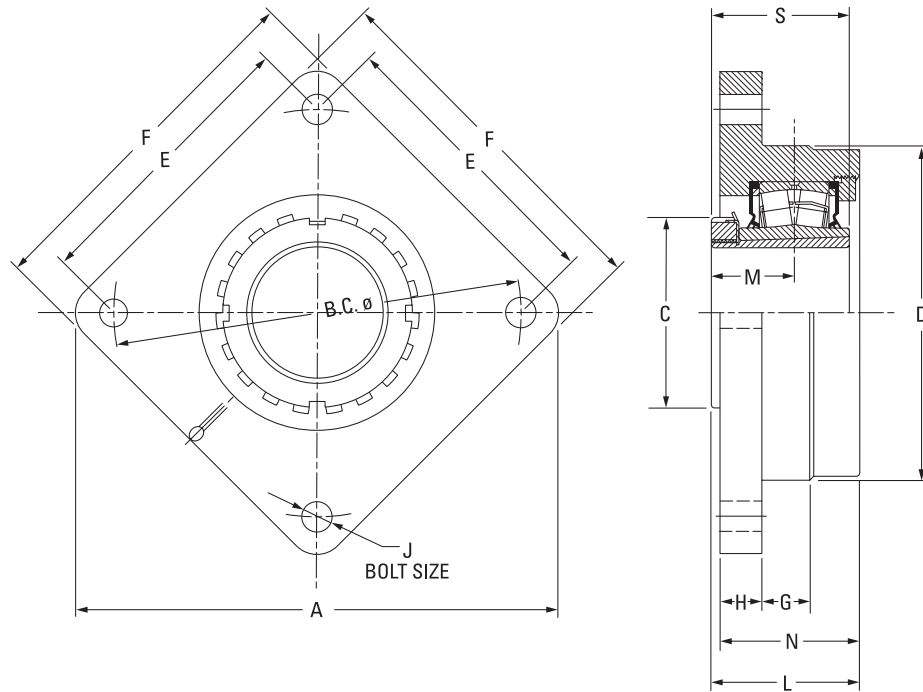

Bearing Part No.	Shaft Dia.	Bearing No.	A	B.C.	C	D ⁽¹⁾	E	F	G	H	J	L	M	N	S	Wt.
			mm in.	mm in.	mm in.	mm in.	mm in.	mm in.	mm in.	mm in.	mm in.	mm in.	mm in.	mm in.	mm in.	mm in.
TAFC15K207S	2 7/16 in.	22215	255.0	215.1	98.0	169.9	152.4	192.0	25.4	23.9	16	79.5	43.9	64.8	72.9	11.3
TAFC15K208S	2 1/2 in.		10.04	8.47	3.86	6.690	6.00	7.56	1.00	0.94	5/8	3.13	1.73	2.55	2.87	25
TAFC15K065S	65 mm															
TAFC17K215S	2 15/16 in.	22217	282.4	240.0	110.0	190.0	169.7	212.1	25.4	25.4	16	88.6	49.8	69.9	82.0	13.6
TAFC17K300S	3 in.		11.12	9.45	4.33	7.480	6.68	8.35	1.00	1.00	5/8	3.49	1.96	2.75	3.23	30
TAFC17K075S	75 mm															
TAFC20K307S	3 7/16 in.	22220	330.2	279.9	130.0	230.1	197.9	247.9	31.8	28.7	20	105.7	58.4	94.2	97.0	18.1
TAFC20K308S	3 1/2 in.		13.00	11.02	5.12	9.060	7.79	9.76	1.25	1.13	3/4	4.16	2.30	3.71	3.82	40
TAFC20K090S	90 mm															
TAFC22K315S	3 15/16 in.	22222	367.0	309.9	145.0	255.0	219.2	274.3	44.5	26.4	20	113.0	63.0	101.1	104.9	27.2
TAFC22K400S	4 in.		14.45	12.20	5.71	10.039	8.63	10.80	1.75	1.04	3/4	4.45	2.48	3.98	4.13	60
TAFC22K100S	100 mm															
TAFC26K407S	4 7/16 in.	22226	411.5	355.1	165.1	290.0	251.0	298.5	41.9	32.0	24	130.6	71.9	114.3	120.9	42.6
TAFC26K408S	4 1/2 in.		16.20	13.98	6.50	11.417	9.88	11.75	1.65	1.26	7/8	5.14	2.83	4.50	4.76	94
TAFC26K115S	115 mm															

⁽¹⁾Pilot tolerance: +0/-0.05 mm (+0/-0.002 in.).

TAFB SQUARE FLANGE BLOCKS

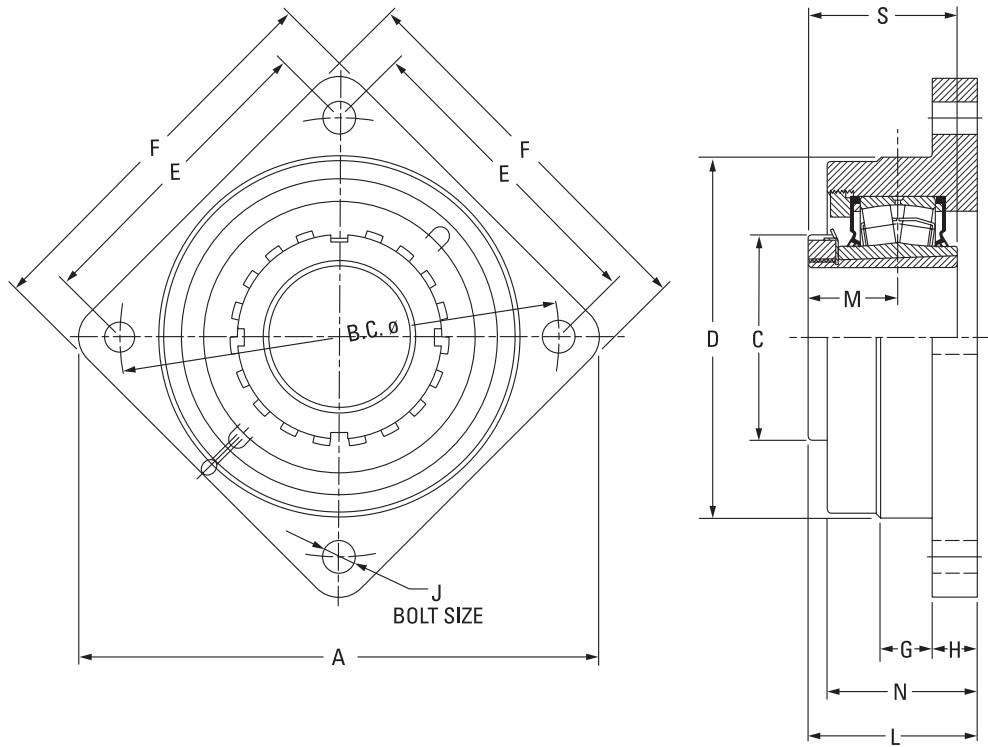

Bearing Part No.	Shaft Dia.	Bearing No.	A	B.C.	C	D	E	F	G	H	J	L	M	N	S	Wt.
	mm in.		mm in.	mm in.	mm in.	mm in.	mm in.	mm in.	mm in.	mm in.	mm in.	mm in.	mm in.	mm in.	mm in.	kg lbs.
TAFB15K207S	2 7/16 in.	22215	255.0	215.1	98.0	169.9	152.4	192.0	25.4	23.9	16	73.7	43.9	64.8	72.9	11.3
TAFB15K208S	2 1/2 in.		10.04	8.47	3.86	6.69	6.00	7.56	1.00	0.94	5/8	2.90	1.73	2.55	2.87	25
TAFB15K065S	65 mm															
TAFB17K215S	2 15/16 in.	22217	282.4	240.0	110.0	190.0	169.7	212.1	25.4	25.4	16	88.6	49.8	69.9	82.0	13.6
TAFB17K300S	3 in.		11.12	9.45	4.33	7.48	6.68	8.35	1.00	1.00	5/8	3.49	1.96	2.75	3.23	30
TAFB17K075S	75 mm															
TAFB20K307S	3 7/16 in.	22220	330.2	280.0	130.0	230.1	197.9	247.9	31.8	28.7	20	105.7	58.4	94.2	97.0	18.1
TAFB20K308S	3 1/2 in.		13.00	11.02	5.12	9.06	7.79	9.76	1.25	1.13	3/4	4.16	2.30	3.71	3.82	40
TAFB20K090S	90 mm															
TAFB22K315S	3 15/16 in.	22222	367.0	309.9	145.0	255.0	219.2	279.4	44.5	26.4	20	113.0	63.0	101.1	104.9	27.2
TAFB22K400S	4 in.		14.45	12.20	5.71	10.04	8.63	11.00	1.75	1.04	3/4	4.45	2.48	3.98	4.13	60
TAFB22K100S	100 mm															
TAFB26K407S	4 7/16 in.	22226	411.5	354.8	165.1	290.0	251.0	298.5	41.9	32.0	24	130.6	71.9	114.3	120.9	42.6
TAFB26K408S	4 1/2 in.		16.20	13.97	6.50	11.42	9.88	11.75	1.65	1.26	7/8	5.14	2.83	4.50	4.76	94
TAFB26K115S	115 mm															

SPHERICAL ROLLER BEARING SOLID-BLOCK HOUSED UNITS

TA/DV SERIES • DVF SQUARE FLANGE BLOCKS

DVF SQUARE FLANGE BLOCKS

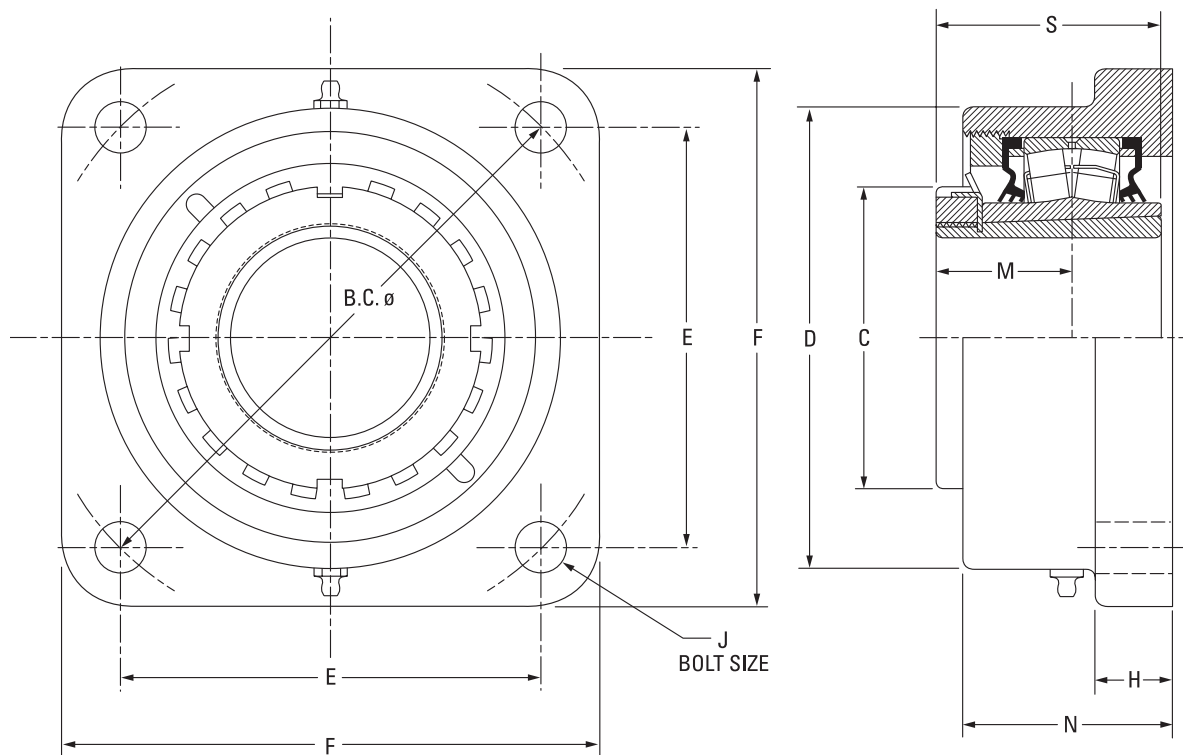

Bearing Part No.	Shaft Dia.	Bearing No.	B.C.	C	D	E	F	H	J	M	N	S	Wt.
	mm in.		mm in.	mm in.	mm in.	mm in.	mm in.	mm in.	mm in.	mm in.	mm in.	mm in.	kg lbs.
DVF09K107S	1 7/16 in.	22209	125.7 4.95	65.0 2.56	101.6 4.00	88.9 3.50	117.6 4.63	19.1 0.75	12 1/2	30.7 1.21	56.1 2.21	50.3 1.98	5.0 11
DVF09K108S	1 1/2 in.	22209	148.3	65.0	107.8	104.9	136.7	19.1	12	30.7	56.1	50.3	5.0
DVF09K040S	40 mm	22209	5.84	2.56	4.25	4.13	5.38	0.75	1/2	1.21	2.21	1.98	11
DVF10K111S	1 11/16 in.	22210	148.3 5.84	70.1 2.76	118.4 4.66	104.9 4.13	136.7 5.38	22.4 0.88	12 1/2	33.5 1.32	52.3 2.06	55.1 2.17	5.5 12
DVF10K112S	1 3/4 in.	22210	157.2	70.1	118.4	111.3	143.0	22.4	12	33.5	52.3	55.1	5.5
DVF10K045S	45 mm	22210	6.19	2.76	4.66	4.38	5.63	0.88	1/2	1.32	2.06	2.17	12
DVF11K115S	1 15/16 in.	22211	157.2	74.9	121.9	111.3	139.7	22.4	12	35.6	65.0	58.9	5.44
DVF11K200S	2 in.	22211	6.19	2.95	4.80	4.38	5.50	0.88	1/2	1.40	2.56	2.32	12
DVF11K050S	50 mm	22211	6.19	2.95	4.80	4.38	5.50	0.88	1/2	1.40	2.56	2.32	12
DVF13K203S	2 3/16 in.	22213	175.0	85.1	137.9	124.0	157.2	25.4	16	39.6	66.8	65.0	6.8
DVF13K204S	2 1/4 in.	22213	6.89	3.35	5.43	4.88	6.19	1.00	5/8	1.56	2.63	2.56	15
DVF13K060S	60 mm	22213	6.89	3.35	5.43	4.88	6.19	1.00	5/8	1.56	2.63	2.56	15
DVF15K207S	2 7/16 in.	22215	193.0	98.0	146.0	136.7	168.4	25.4	16	43.9	72.4	72.9	8.2
DVF15K208S	2 1/2 in.	22215	7.60	3.86	5.75	5.38	6.63	1.00	5/8	1.73	2.85	2.87	18
DVF15K065S	65 mm	22215	7.60	3.86	5.75	5.38	6.63	1.00	5/8	1.73	2.85	2.87	18
DVF17K215S	2 15/16 in.	22217	215.4	110.0	170.7	152.4	189.0	26.9	20	49.8	77.0	82.0	12.7
DVF17K300S	3 in.	22217	8.48	4.33	6.72	6.00	7.44	1.06	3/4	1.96	3.03	3.23	28
DVF17K075S	75 mm	22217	8.48	4.33	6.72	6.00	7.44	1.06	3/4	1.96	3.03	3.23	28
DVF20K307S	3 7/16 in.	22220	251.5	130.0	193.8	177.8	219.2	33.3	20	58.4	84.1	97.0	17.7
DVF20K308S	3 1/2 in.	22220	9.90	5.12	7.63	7.00	8.63	1.31	3/4	2.30	3.31	3.82	39
DVF20K090S	90 mm	22220	9.90	5.12	7.63	7.00	8.63	1.31	3/4	2.30	3.31	3.82	39
DVF22K315S	3 15/16 in.	22222	278.4	145.0	215.9	196.9	253.2	38.1	24	63.0	103.1	104.9	24.0
DVF22K400S	4 in.	22222	10.96	5.71	8.50	7.75	9.97	1.50	7/8	2.48	4.06	4.13	53
DVF22K100S	100 mm	22222	10.96	5.71	8.50	7.75	9.97	1.50	7/8	2.48	4.06	4.13	53
DVF26K407S	4 7/16 in.	22226	314.5	165.1	263.7	222.3	276.4	38.1	24	71.9	106.9	120.9	34.0
DVF26K408S	4 1/2 in.	22226	12.38	6.50	10.38	8.75	10.88	1.50	7/8	2.83	4.21	4.76	75
DVF26K115S	115 mm	22226	12.38	6.50	10.38	8.75	10.88	1.50	7/8	2.83	4.21	4.76	75

TAFK 9000 SERIES SQUARE FLANGE BLOCKS

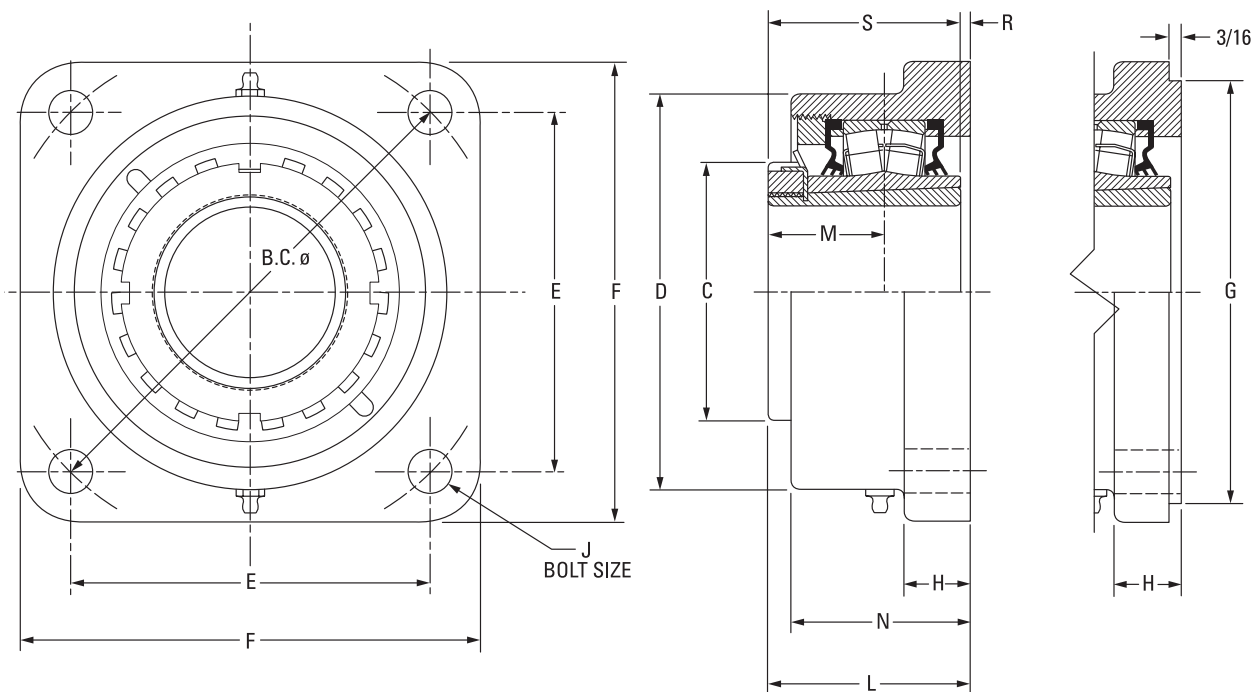

Bearing Part No.	Shaft Dia.	Bearing No.	B.C.	C	D	E	F	G ⁽¹⁾⁽²⁾⁽³⁾	H	J	L FIX	L EXP	M	N	R	S	Wt.
																	kg lbs.
TAFK11K115S	1 15/16 in.	22211	161.5 6.36	74.9 2.95	130.3 5.13	114.3 4.50	149.4 5.88	127.00 5.000	25.4 1.00	16 5/8	71.6 2.82	72.9 2.87	35.6 1.40	66.8 2.63	12.7 0.50	58.9 2.32	5.0
TAFK11K200S	2 in.																11
TAFK11K050S	50 mm																11
TAFK13K203S	2 3/16 in.	22213	180.8 7.12	85.1 3.35	146.1 5.75	127.8 5.03	157.2 6.19	138.13 5.438	25.4 1.00	16 5/8	77.7 3.06	79.8 3.14	39.6 1.56	72.4 2.85	12.7 0.50	65.0 2.56	6.4
TAFK13K204S	2 1/4 in.																14
TAFK13K060S	60 mm																14
TAFK15K207S	2 7/16 in.	22215	215.9 8.50	98.0 3.86	168.9 6.65	152.7 6.01	189.0 7.44	160.35 6.313	26.9 1.06	20 3/4	84.8 3.34	86.9 3.42	43.9 1.73	76.2 3.00	11.9 0.47	72.9 2.87	7.7
TAFK15K208S	2 1/2 in.																17
TAFK15K065S	65 mm																17
TAFK17K215S	2 15/16 in.	22217	41.3 9.50	110.0 4.33	193.8 7.63	170.7 6.72	212.9 8.38	187.33 7.375	33.3 1.31	20 3/4	96.3 3.79	98.3 3.87	49.8 1.96	84.1 3.31	14.2 0.56	82.0 3.23	10.4
TAFK17K300S	3 in.																23
TAFK17K075S	75 mm																23
TAFK20K307S	3 7/16 in.	22220	298.5 11.75	130.0 5.12	215.9 8.50	211.1 8.31	268.2 10.56	225.43 8.875	38.1 1.50	24 7/8	114.6 4.51	116.6 4.59	58.4 2.30	103.1 4.06	17.5 0.69	97.0 3.82	15.9
TAFK20K308S	3 1/2 in.																35
TAFK20K090S	90 mm																35
TAFK22K315S ⁽⁴⁾	3 15/16 in.	22222	327.2 12.88 ⁽⁴⁾	145.0 5.71	256.5 10.10	163.6 6.44 ⁽⁴⁾	384.3 15.13	263.53 10.375	38.1 1.50	24 1 ⁽⁴⁾	117.3 4.62	119.4 4.70	63.0 2.48	106.9 4.21	12.4 0.49	104.9 4.13	24.9
TAFK22K400S ⁽⁴⁾	4 in.																55
TAFK22K100S ⁽⁴⁾	100 mm																55
TAFK26K407S ⁽⁴⁾	4 7/16 in.	22226	355.6 14.00 ⁽⁴⁾	165.1 6.50	284.2 11.19	177.8 7.00 ⁽⁴⁾	419.1 16.50	284.18 11.188	38.1 1.50	27 1 1/8 ⁽⁴⁾	147.3 5.80	149.4 5.88	71.9 2.83	135.1 5.32	26.4 1.04	120.9 4.76	49.0
TAFK26K408S ⁽⁴⁾	4 1/2 in.																108
TAFK26K115S ⁽⁴⁾	115 mm																108

⁽¹⁾Pilot tolerance: +0/-0.05 mm (+0/-0.002 in.).

⁽²⁾Add (p) to the end of the housing designation in the part number to order with pilot using G dimension.

⁽³⁾Piloted flange blocks will be quoted (price and delivery) upon request. For optional spigot on flange side, insert the letter P as seen in the following example: QMFP**J***S.

⁽⁴⁾Six-bolt housing.

SPHERICAL ROLLER BEARING SOLID-BLOCK HOUSED UNITS

TA/DV SERIES • TAMC CARTRIDGE BLOCKS

TAMC CARTRIDGE BLOCKS

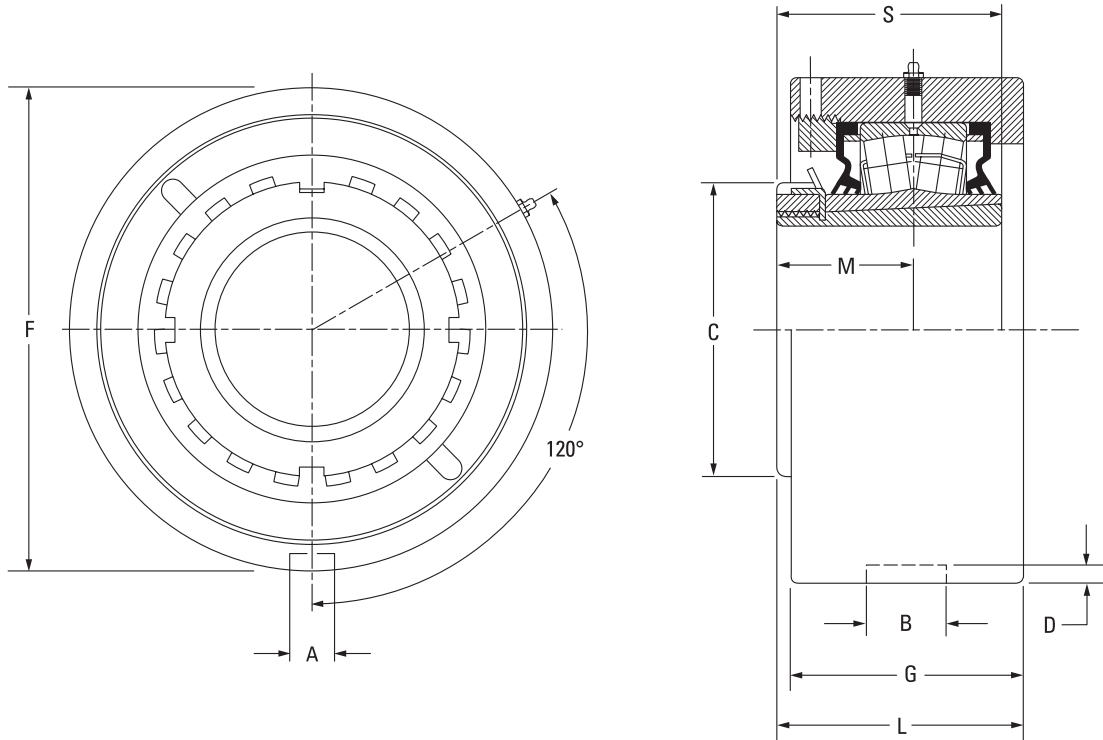

Bearing Part No.	Shaft Dia.	Bearing No.	A	B	C	D	F	G	L _{FIX}	L _{EXP}	M	S	Wt.
	mm in.		mm in.	mm in.	mm in.	mm in.	mm in.	mm in.	mm in.	mm in.	mm in.	mm in.	kg lbs.
TAMC11K115S	1 15/16 in.	22211	13.5 0.530	23.0 0.906	74.9 2.95	4.8 0.188	115.09 (+0/-0.05) 4.531 (+0/-0.002)	55.4 2.18	63.2 2.49	64.5 2.54	35.6 1.40	58.9 2.32	4.5 10
TAMC11K200S	2 in.												
TAMC11K050S	50 mm												
TAMC13K203S	2 3/16 in.	22213	13.5 0.530	23.0 0.906	85.1 3.35	4.8 0.188	127.00 (+0/-0.05) 5.000 (+0/-0.002)	67.1 2.64	70.9 2.79	72.9 2.87	39.6 1.56	65.0 2.56	5.4 12
TAMC13K204S	2 1/4 in.												
TAMC13K060S	60 mm												
TAMC15K207S	2 7/16 in.	22215	15.1 0.594	26.2 1.032	98.0 3.86	6.4 0.250	149.23 (+0/-0.05) 5.875 (+0/-0.002)	70.6 2.78	78.2 3.08	80.3 3.16	43.9 1.73	72.9 2.87	8.2 18
TAMC15K208S	2 1/2 in.												
TAMC15K065S	65 mm												
TAMC17K215S	2 15/16 in.	22217	15.1 0.594	27.5 1.083	110.0 4.33	7.1 0.281	171.45 (+0/-0.05) 6.750 (+0/-0.002)	74.9 2.95	87.4 3.44	89.4 3.52	49.8 1.96	82.0 3.23	11.8 26
TAMC17K300S	3 in.												
TAMC17K075S	75 mm												
TAMC20K307S	3 7/16 in.	22220	19.8 0.781	32.5 1.281	130.0 5.12	8.0 0.313	206.38 (+0/-0.05) 8.125 (+0/-0.002)	85.6 3.37	101.3 3.99	103.4 4.07	58.4 2.30	97.0 3.82	14.5 32
TAMC20K308S	3 1/2 in.												
TAMC20K090S	90 mm												
TAMC22K315S	3 15/16 in.	22222	19.8 0.781	32.5 1.281	145.0 5.71	8.0 0.313	222.25 (+0/-0.08) 8.750 (+0/-0.003)	97.8 3.85	112.0 4.41	114.0 4.49	63.0 2.48	104.9 4.13	18.1 40
TAMC22K400S	4 in.												
TAMC22K100S	100 mm												
TAMC26K407S	4 7/16 in.	22226	19.8 0.780	38.1 1.500	165.1 6.50	8.0 0.313	265.10 (+0/-0.08) 10.437 (+0/-0.003)	104.4 4.11	124.2 4.89	126.2 4.97	71.9 2.83	120.9 4.76	23.6 52
TAMC26K408S	4 1/2 in.												
TAMC26K115S	115 mm												

TAKE-UP FRAMES⁽¹⁾
QMTF TAKE-UP FRAMES

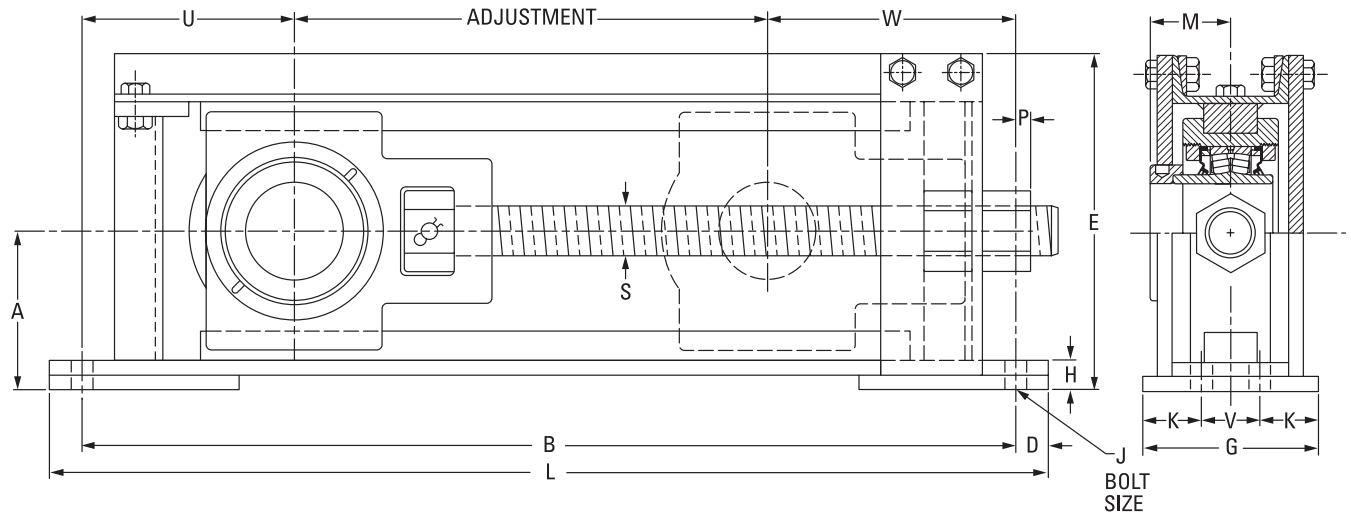

Frame Part No.	Travel Nom.	Travel Adj.	A	B	D	E	G	H	J	K	L	M	P	S	U	V	W	No. of Bolts Req.	Wt.
			mm in.	mm in.	mm in.	mm in.	mm in.	mm in.	mm in.	mm in.	mm in.	mm in.	mm in.	mm in.	mm in.	mm in.	mm in.		
QMTF12-115	12	419.1 16.50	100.1 3.94	698.5 27.50	25.4 1.00	210.3 8.28	101.6 4.00	31.8 1.25	16 5/8	-	749.3 29.50	47.8 1.88	31.8 1.25	1-5 ACME	136.7 5.38	-	143.0 5.63	2	27.216 60
QMTF12-203	12	431.8 17.00	106.4 4.19	698.5 27.50	25.4 1.00	220.0 8.66	101.6 4.00	35.1 1.38	16 5/8	-	749.3 29.50	50.8 2.00	41.4 1.63	1.125-5 ACME	115.8 4.56	-	150.9 5.94	2	29.484 65
QMTF12-207	12	421.6 16.60	111.3 4.38	723.9 28.50	25.4 1.00	233.4 9.19	101.6 4.00	28.7 1.13	20 3/4	-	774.7 30.50	54.1 2.13	44.5 1.75	1.25-5 ACME	134.9 5.31	-	166.6 6.56	2	32.205 71
QMTF12-215	12	393.7 15.50	129.3 5.09	774.7 30.50	25.4 1.00	272.8 10.74	127.0 5.00	28.7 1.13	16 5/8	38.1 1.50	825.5 32.50	60.5 2.38	12.7 0.50	1.5-4 ACME	165.1 6.50	50.8 2.00	215.9 8.50	4	49.442 109
QMTF12-307	12	393.7 15.50	143.0 5.63	812.8 32.00	28.7 1.13	295.4 11.63	127.0 5.00	26.2 1.03	20 3/4	38.1 1.50	870.0 34.25	65.5 2.58	25.4 1.00	1.75-4 ACME	185.7 7.31	50.8 2.00	233.4 9.19	4	62.596 138
QMTF12-315	12	457.2 18.00	177.8 7.00	914.4 36.00	31.8 1.25	367.5 14.47	152.4 6.00	36.6 1.44	20 3/4	44.5 1.75	977.9 38.50	75.2 2.96	41.4 1.63	2-4 ACME	190.5 7.50	63.5 2.50	265.2 10.44	4	86.636 191
QMTF18-207	18	574.0 22.60	111.3 4.38	876.3 34.50	25.4 1.00	234.2 9.22	101.6 4.00	26.9 1.06	20 3/4	-	927.1 36.50	54.1 2.13	44.5 1.75	1.25-5 ACME	139.7 5.50	-	162.6 6.40	2	36.741 81
QMTF18-215	18	546.1 21.50	129.3 5.09	927.1 36.50	25.4 1.00	272.8 10.74	127.0 5.00	28.7 1.13	16 5/8	38.1 1.50	977.9 38.50	60.5 2.38	12.7 0.50	1.5-4 ACME	165.1 6.50	50.8 2.00	215.9 8.50	4	54.431 120
QMTF18-307	18	546.1 21.50	143.0 5.63	965.2 38.00	28.7 1.13	295.4 11.63	127.0 5.00	26.2 1.03	20 3/4	38.1 1.50	1022.4 40.25	65.5 2.58	25.4 1.00	1.75-4 ACME	185.7 7.31	50.8 2.00	233.4 9.19	4	70.760 156
QMTF18-315	18	609.6 24.00	177.8 7.00	1066.8 42.00	31.8 1.25	366.8 14.44	152.4 6.00	36.6 1.44	20 3/4	44.5 1.75	1130.3 44.50	75.2 2.96	41.4 1.63	2-4 ACME	190.5 7.50	63.5 2.50	265.2 10.44	4	101.150 223
QMTF24-207	24	726.4 28.60	111.3 4.38	1028.7 40.50	25.4 1.00	233.4 9.19	101.6 4.00	28.7 1.13	20 3/4	-	1079.5 42.50	54.1 2.13	44.5 1.75	1.25-5 ACME	115.8 4.56	-	166.6 6.56	2	41.277 91
QMTF24-215	24	698.5 27.50	129.3 5.09	1079.5 42.50	25.4 1.00	271.5 10.69	127.0 5.00	24.6 0.97	16 5/8	38.1 1.50	1130.3 44.50	60.5 2.38	12.7 0.50	1.5-4 ACME	165.1 6.50	50.8 2.00	215.9 8.50	4	63.957 141
QMTF24-307	24	698.5 27.50	143.0 5.63	1117.6 44.00	28.7 1.13	295.4 11.63	127.0 5.00	26.2 1.03	20 3/4	38.1 1.50	1174.8 46.25	65.5 2.58	25.4 1.00	1.75-4 ACME	185.7 7.31	50.8 2.00	233.4 9.19	4	81.193 179
QMTF24-315	24	762.0 30.00	177.8 7.00	1219.2 48.00	31.8 1.25	367.5 14.47	152.4 6.00	36.6 1.44	20 3/4	44.5 1.75	1282.7 50.50	75.2 2.96	41.4 1.63	2-4 ACME	190.5 7.50	63.5 2.50	265.2 10.44	4	112.940 249

⁽¹⁾Frame only. Bearing unit must be ordered separately. See pages C-98 (V-Lock), C-125, C-120 (CL) and C-149 (EC) for information on take-up bearing units.
 NOTE: All take-up frames come with Acme threaded rod.

SPHERICAL ROLLER BEARING SOLID-BLOCK HOUSED UNITS

TAKE-UP FRAMES • QMT PILLOW BLOCK TAKE-UP FRAMES

QMT PILLOW BLOCK TAKE-UP FRAMES⁽¹⁾

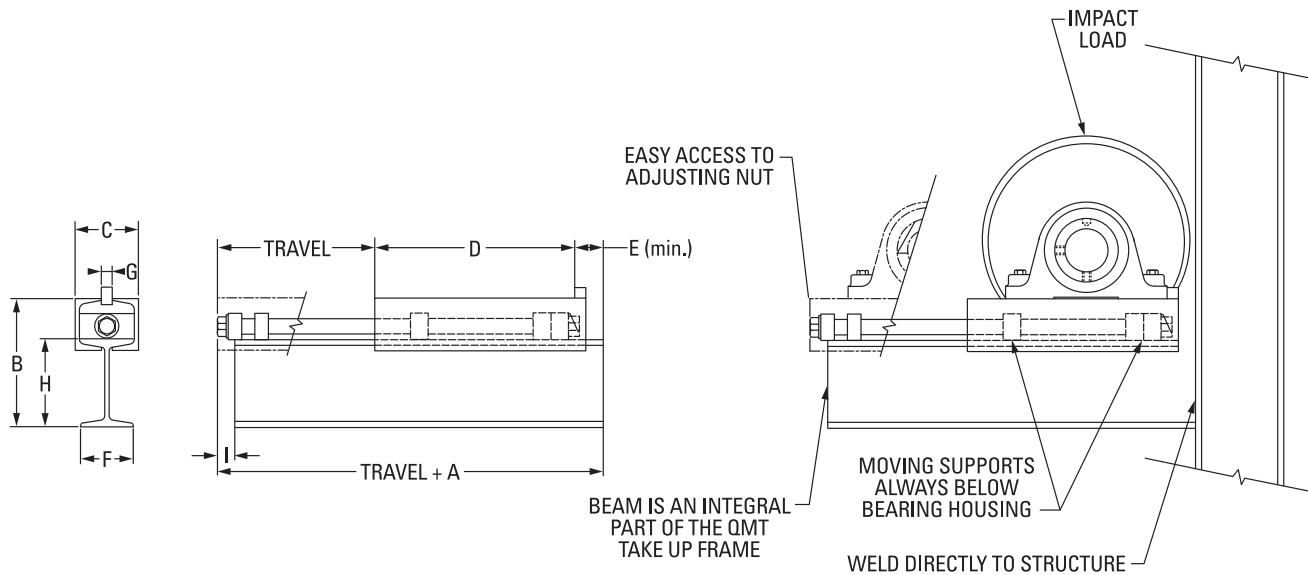

Frame Part No.	Bearing Size	Travel	A	B	C	D	E	F	G	H	I	Wt.
			mm in.	mm in.	mm in.	mm in.	mm in.	mm in.	mm in.	mm in.	mm in.	kg lbs.
QMT1 X 9	1 7/16 in. – 2 15/16 in.	9	330.2 13.0	187.3 7.375	92.1 3.625	289.1 11.38	41.4 1.63	76.2 3.00	20 3/4	127.0 5.0	25.4 1.0	11.793 26
QMT1 X 12	1 7/16 in. – 2 15/16 in.	12	330.2 13.0	187.3 7.375	92.1 3.625	289.1 11.38	41.4 1.63	76.2 3.00	20 3/4	127.0 5.0	25.4 1.0	13.608 30
QMT1 X 18	1 7/16 in. – 2 15/16 in.	18	330.2 13.0	187.3 7.375	92.1 3.625	289.1 11.38	41.4 1.63	76.2 3.00	20 3/4	127.0 5.0	25.4 1.0	16.329 36
QMT1 X 24	1 7/16 in. – 2 15/16 in.	24	330.2 13.0	187.3 7.375	92.1 3.625	289.1 11.38	41.4 1.63	76.2 3.00	20 3/4	127.0 5.0	25.4 1.0	19.051 42
QMT2 X 18	2 15/16 in. – 4 7/16 in.	18	482.6 19.0	311.2 12.25	125.4 4.938	431.8 17.00	50.8 2.00	106.4 4.19	24 1	203.2 8.0	38.1 1.5	33.566 74
QMT2 X 24	2 15/16 in. – 4 7/16 in.	24	482.6 19.0	311.2 12.25	125.4 4.938	431.8 17.00	50.8 2.00	106.4 4.19	24 1	203.2 8.0	38.1 1.5	40.823 90
QMT2 X 36	2 15/16 in. – 4 7/16 in.	36	482.6 19.0	311.2 12.25	125.4 4.938	431.8 17.00	50.8 2.00	106.4 4.19	24 1	203.2 8.0	38.1 1.5	43.545 96

⁽¹⁾Frame only. Bearing unit must be ordered separately.
NOTE: All take-up frames come with Acme threaded rod.

INDEX

SPHERICAL ROLLER BEARING SOLID-BLOCK HOUSED UNITS

DVC Piloted Flange Cartridges	C-163	QVFB and QVFB Flange Blocks – Tapered Bore Equivalent. . .	C-89
DVF Square Flange Blocks	C-166	QVFC and QVFC Piloted Flange Cartridges –	
DVP Two-Bolt Pillow Blocks	C-155	Tapered Adapter Equivalent.	C-90
DVPF Four-Bolt Pillow Blocks	C-159	QVFK and QVFK 9000 Series Square Flange Blocks –	
Engineering	C-7	Tapered Bore Equivalent	C-93
QAAFX 5000 Series Flange Blocks	C-120	QVFL and QVFL Square Flange Blocks –	
QAAPX 5000 Series Four-Bolt Pillow Blocks	C-111	Straight Bore Equivalent.	C-91
QAAPXT 5000 Series Two-Bolt Pillow Blocks	C-107	QVFX and QVFX 5000 Series Square Flange Blocks –	
QAC and QAC Piloted Flange Cartridges	C-112	Straight Bore Equivalent.	C-92
QACW and QACW Piloted Flange Cartridges	C-114	QVFY and QVFY Round Flange Blocks –	
QAF and QAF Square Flange Blocks	C-116	Straight Bore Equivalent.	C-94
QAFI and QAFI Square Flange Blocks	C-118	QVMC and QVMC Cartridge Blocks –	
QAFY and QAFY Round Flange Blocks	C-121	Tapered Bore Equivalent	C-97
QAMC and QAMC Cartridge Blocks	C-123	QVVP Two-Bolt Pillow Blocks – Straight Bore Equivalent . . .	C-75
QAMH and QAMH Hanger Blocks	C-127	QVVP SAF Two-Bolt Pillow Blocks –	
QAP and QAP Two-Bolt Pillow Blocks	C-101	Tapered Bore Equivalent	C-77
QAPF and QAPF Four-Bolt Pillow Blocks	C-108	QVVPF Four-Bolt Pillow Blocks – Straight Bore Equivalent . . .	C-81
QAPL and QAPL Two-Bolt Pillow Blocks	C-103	QVVPG SN-Style Four-Bolt Pillow Blocks	
QAPR and QAPR Four-Bolt Pillow Blocks	C-110	Tapered Bore Equivalent	C-85
QASN and QASN SN-Style Two-Bolt Pillow Blocks –		QVVPK SAF-Style Four-Bolt Pillow Blocks –	
Pure Metric Design	C-105	Tapered Bore Equivalent	C-86
QATU and QATU Take-Up Blocks	C-125	QVVPK 9000 Series Four-Bolt Pillow Blocks –	
QMC Piloted Flange Cartridges	C-140	Tapered Bore Equivalent	C-87
QMCW Piloted Flange Cartridges	C-141	QVVPKT 9000 Series Two-Bolt Pillow Blocks –	
QMF Four-Bolt Square Flange Blocks	C-143	Tapered Bore Equivalent	C-80
QMFL Four-Bolt Square Flange Blocks	C-144	QVVPL Two-Bolt Pillow Blocks – Straight Bore Equivalent . . .	C-76
QMF 5000 Series Square Flange Blocks	C-147	QVVPN SN-Style Two-Bolt Pillow Blocks –	
QMFY Round Flange Blocks	C-145	Tapered Bore Equivalent	C-78
QMMC Cartridge Blocks	C-150	QVVPR Four-Bolt Pillow Blocks – Straight Bore Equivalent. . .	C-82
QMMH Hanger Blocks	C-152	QVVPS 5000 Series Four-Bolt Pillow Blocks –	
QMP Two-Bolt Pillow Blocks	C-131	Straight Bore Equivalent.	C-83
QMPF Four-Bolt Pillow Blocks	C-133	QVVPT 5000 Series Two-Bolt Pillow Blocks –	
QMPH/QMPG Four-Bolt Pillow Blocks	C-135	Straight Bore Equivalent.	C-84
QMPL Two-Bolt Pillow Blocks	C-132	QVVSN SN-Style Two-Bolt Pillow Blocks –	
QMPR Four-Bolt Pillow Blocks	C-134	Pure Metric Design	C-79
QMPX 5000 Series Four-Bolt Pillow Blocks	C-136	QVVTU Take-Up Blocks – Straight Bore Equivalent.	C-98
QMPXT 5000 Series Two-Bolt Pillow Blocks	C-137	Seal and Cover Options	C-59
QMSN SN-Style Two-Bolt Pillow Blocks –		Spherical Roller Bearing Solid-Block Housed Units	C-1
Pure Metric Design	C-138	Spherical Roller Bearing Solid-Block Housed Unit	
QMT Pillow Block Take-Up Frames	C-170	Product Data Tables	C-53
QMTF Take-Up Frames	C-169	TAFB Square Flange Blocks	C-165
QMTU Take-Up Blocks	C-149	TAFD Square Piloted Flange Cartridges	C-164
QVC and QVC Piloted Flange Cartridges –		TAFK 9000 Series Square Flange Blocks	C-167
Straight Bore Equivalent.	C-95	Take-Up Frames	C-169
QVCW and QVCW Piloted Flange Cartridges –		TAMC Cartridge Blocks	C-168
Straight Bore Equivalent.	C-96	TAPA SAF-Style Two-Bolt Pillow Blocks	C-156
QVF and QVF Square Flange Blocks –		TAPG SN-Style Four-Bolt Pillow Blocks	C-162
Straight Bore Equivalent.	C-88	TAPH SAF-Style Four-Bolt Pillow Blocks	C-161
		TAPK 9000 Series Four-Bolt Pillow Blocks	C-160
		TAPKT 9000 Series Two-Bolt Pillow Blocks	C-158
		TAPN SN-Style Two-Bolt Pillow Blocks	C-157

TIMKEN

The Timken team applies their know-how to improve the reliability and performance of machinery in diverse markets worldwide. The company designs, makes and markets high-performance mechanical components, including bearings, gears, chain and related mechanical power transmission products and services.

www.timken.com