

# **SEALMASTER<sup>®</sup>**

## **GOLD BEARING PRODUCTS**

***MOUNTED  
BALL BEARINGS***

***MOUNTED  
ROLLER BEARINGS***

***ROD ENDS &  
SPHERICAL  
BEARINGS***

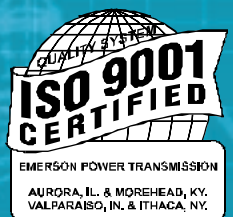

**Catalog BP-97**

# TABLE OF CONTENTS

## **SEALMASTER** *Gold Bearing Products...*

### **SEALMASTER Gold Mounted Ball Bearings...**

**"Good As Gold...No Equal!"**

*Standard Products ..... Pages 8-84*

*Featured Products ..... Pages 86-93*



### **SEALMASTER Mounted Roller Bearings...**

**"Tough As They Come!"**

*See Pages 94-127*

**Ball and Roller Application Problem Solvers...See Pages 129-143**



### **SEALMASTER Rod Ends and Spherical Bearings...**

**"Sealmaster, Ask For Them By Name!"**

*See Pages 144-175*



### **Engineering and Installation...**

*See Pages 176-207*

**Catalog Index, ..... See Pages 208-210**

**Standard Terms and Conditions ..... Inside Back Cover**

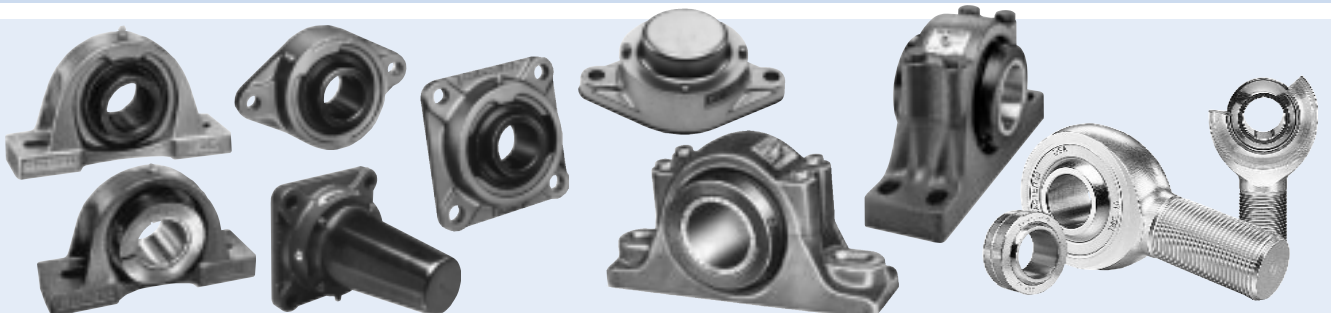
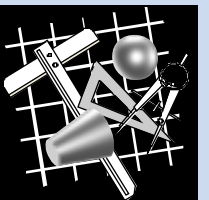

# SEALMASTER® GOLD LINE PRODUCT OFFERING...

## TECHNICAL SUPERIORITY...

### SET SCREW LOCKING

#### Gold Line Mounted Ball Bearings...GOOD AS GOLD!

- Self Aligning.
- Abec 1.
- Wide Inner and Outer Races.
- Conrad Style.
- Deep Groove.
- Expansion Available.
- Solid Cast Iron Housing.
- Relubricable.
- Exclusive Locking Pin and Dimple System.
- Black Oxide Coating.
- Felt Labyrinth Seals.
- Zone Hardened Inner Race.
- Unique Land Riding Metal Retainer.
- 120° Set Screw Placement.
- Diamond Faceted Precision Thread Set Screws.
- Single Set Screw Lock Standard.
- Double Set Screw Lock Available.

The Sealmaster Gold Line bearing platform has become synonymous with problem solving by addressing many factors of bearing operation. Sealmaster Gold Line Mounted Ball Bearings are designed to provide support for radial and thrust loads. Typically, they can achieve higher speeds than tapered roller bearings. Sealmaster Gold Line Ball Bearings are intended to be slip-fit onto a shaft. They have a spherical outer diameter insert and can accept an external misalignment of  $\pm 2^\circ$ . This product line is available in standard and medium duty series. Medium duty bearings have larger housings, higher load-bearing capabilities, but lower speed ratings.

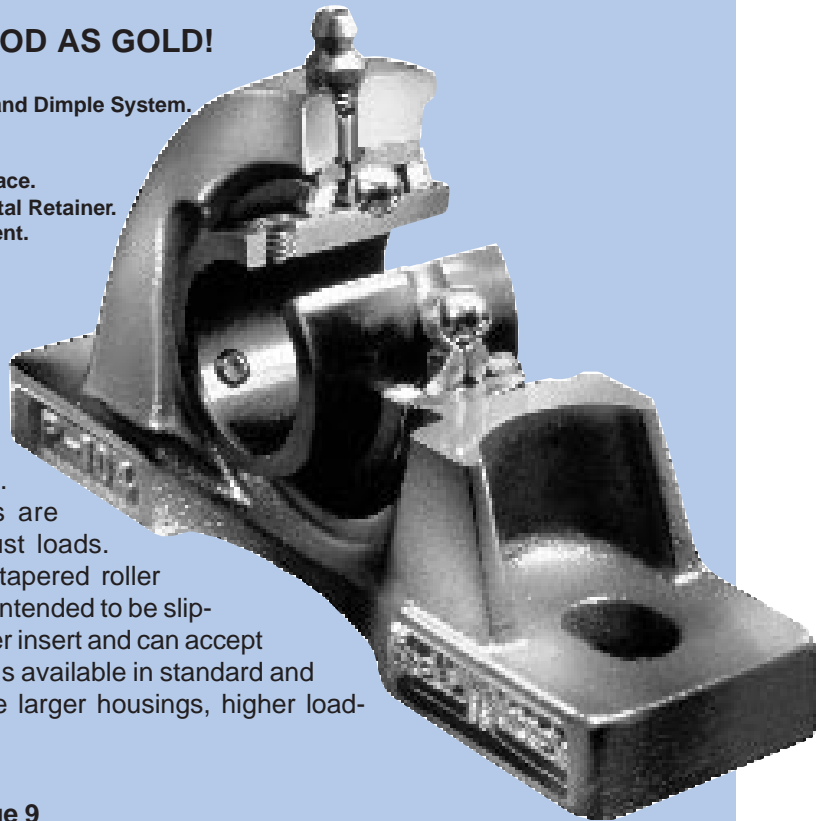

Ball Bearing Set Screw Table of Contents...Page 9

### SKWEZLOC® LOCKING

#### Gold Line Mounted Ball Bearings...GOOD AS GOLD!

- Self Aligning.
- Abec 1.
- Wide Inner and Outer Races.
- Conrad Style.
- Deep Groove.
- Expansion Available.
- Solid Cast Iron Housing.
- Relubricable.
- Exclusive Locking Pin and Dimple System.
- Black Oxide Coating.
- Felt Labyrinth Seals.
- Zone Hardened Inner Race.
- Unique Land Riding Metal Retainer.
- Skwezloc Locking Standard.

The unparalleled **SKWEZLOC** locking collar centers the shaft in the bearing bore...secures the shaft with near-perfect concentricity for quieter operation at higher speeds and simpler installation. Shafts are protected from deep scoring or burring. This locking device combined with the Sealmaster Gold Line ball bearing platform is an excellent performer. Sealmaster Gold Line Mounted Ball Bearings are designed to provide support for radial and thrust loads. Typically, they can achieve higher speeds than tapered roller bearings. Sealmaster Gold Line Mounted Ball Bearings are intended to be slip-fit onto a shaft. They have a spherical outer diameter insert and can accept an external misalignment of  $\pm 2^\circ$ . This product line is available in standard and medium duty series. Medium duty bearings have larger housings, higher load-bearing capabilities, but lower speed ratings.

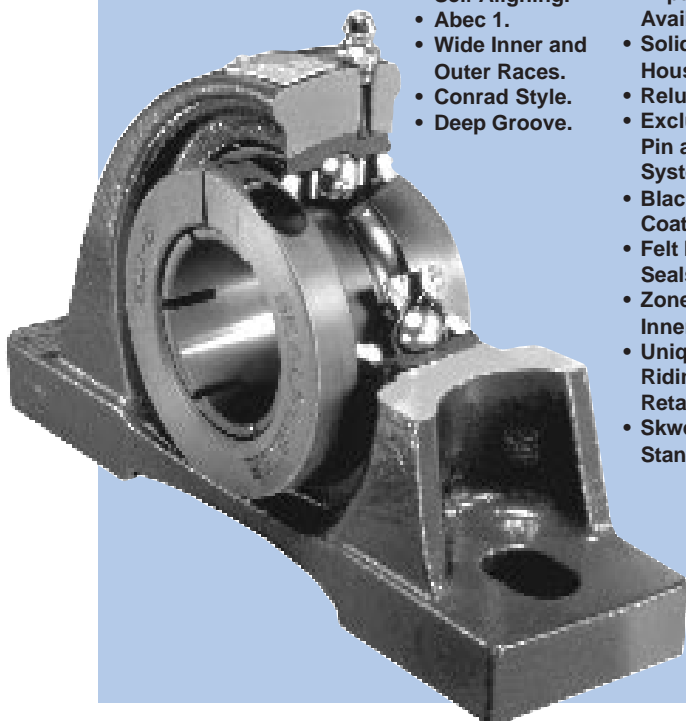

Ball Bearing SKWEZLOC Section...Pages 64-84

# DIFFERENT...BY DESIGN!

## FOCUSED ON INDUSTRY

### SET SCREW LOCKING RPB Series

#### Gold Line Mounted Roller Bearings... TOUGH AS THEY COME!

- Self Aligning.
- Double Row.
- Split Housing.
- Cast Iron Housing.
- Relubricable.
- Single Set Screw Lock Available.
- Double Set Screw Lock Standard.

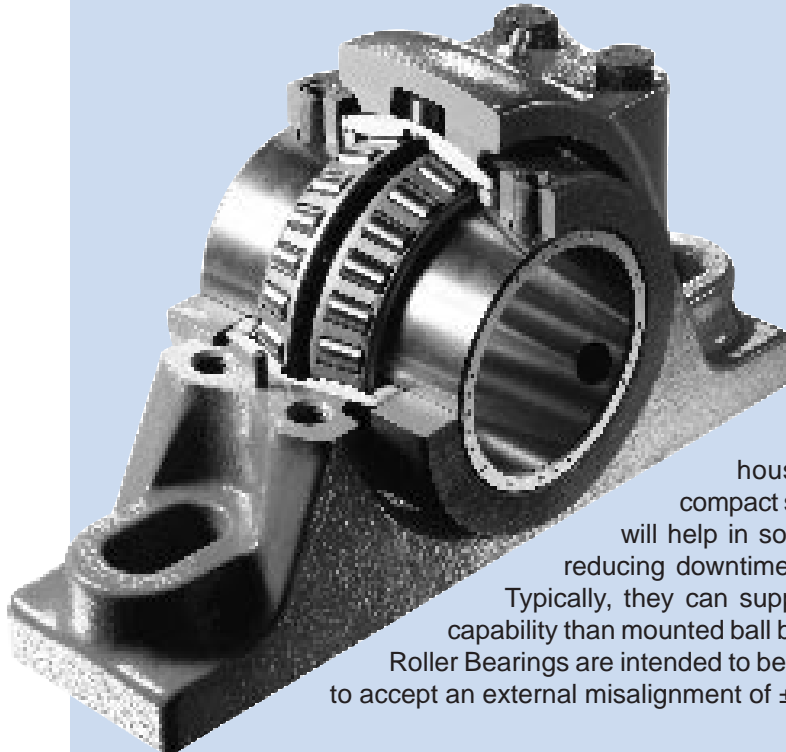

Sealmaster Self-Aligning Mounted Tapered Roller Bearings units provide the dependability, flexibility, and ruggedness required to handle high radial and thrust loads. They combine the time tested assurance of TIMKEN® double row tapered roller bearings with patented outer race and housing features developed by our Engineers. The compact split housing and self-aligning bearing cartridge insert will help in solving difficult application problems while drastically reducing downtime when bearing replacement is ultimately required. Typically, they can support higher loads but have lower maximum speed capability than mounted ball bearings. Sealmaster Self-Aligning Mounted Tapered Roller Bearings are intended to be slip-fit onto a shaft and have a spherical outer insert to accept an external misalignment of  $\pm 3^\circ$ .

Roller Bearing Table of Contents...Page 95

## ROD ENDS and SPHERICAL BEARINGS...

### SEALMASTER Gold Line...ASK FOR THEM BY NAME!

Combining years of innovative bearing design experience with an original manufacturing process, our engineers have developed three-piece rod ends with steel and bronze races for enhanced performance. These quality industrial grade mounted spherical plain bearings are designed to handle low speeds, oscillation, radial loads and moderate thrust loads. Sealmaster Spherical Bearings are intended to be assembled onto a shaft and into a housing. Sealmaster Rod ends can be mounted easily using the threads on the shank. Because of the spherical designs, rod ends and spherical bearings have large misalignment ratings.

- Spherical Plain Bearings.
- Improved Rod End Design.
- Finite Element Analysis Developed.
- Three-Piece Rod Ends.
- Two-piece Rod Ends.
- Self Aligning.
- Close and Consistent Ball-Fit Race.
- Re-engineered Self-Lubricating \*TEFLON and \*DELRIN Rod Ends.
- Precision and Commercial.
- Many available Options.



SEALMASTER GOLD LINE'S UNIQUE DESIGN PLATFORM AND INDUSTRY KNOW-HOW COUPLED WITH FLEXIBLE MANUFACTURING TECHNIQUES AND ADVANCED ANALYTICAL CAPABILITIES MAKE AN UNBEATABLE COMBINATION FOR YOUR MOST DEMANDING APPLICATIONS

Rod End Table of Contents...Page 145

\* TEFLON and \*DELRIN are trademarks of the DuPont Company.

# SEALMASTER® GOLD LINE SOLUTIONS...

Solutions from  
**FEATURED  
PRODUCTS**

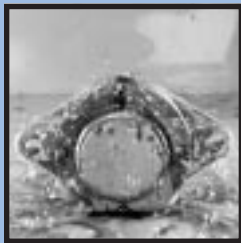

Page 86  
**Beverage Bearings**



Page 88  
**Corrosion DutyBall and Roller Bearings**



Page 122



Page 90  
**Furnace Bearings**



Page 110  
**RPBXT and ERPBXT**



Page 85  
**Metric Bearings**

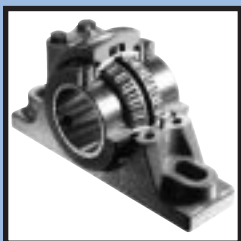

Page 126



## SEALMASTER...

*...Has broad experience developing special end caps and protective closures along with effective materials and corrosion resistant coatings for housing, bearing races and small parts.*

*...Has knowledge of special greases that can be used in special factory lubricated bearings to suit your needs.*

*...Unique locking devices have often maximized bearing reliability in applications where standard bearings did not perform.*

*...Can control fit-ups and clearances with precision and accuracy to account for material expansion and other application dynamics.*

*...Engineers have thoroughly studied applications and developed distinct product lines for increased and reliable bearing performance.*



*...Special seals and shields can be manufactured to guard the bearing from abrasives and corrosive contamination.*

**Felt Seal**



**Backed Off Seal**

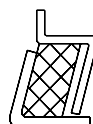

**Web Seal**



**X-Seal**



# FOR CHALLENGING APPLICATIONS



*Sealmaster has years of experience solving problems and can develop new concepts and integrate existing robust designs into your applications for optimal operation efficiency.*



**High Temperature**  
Pages 130-131



**Air Handling**  
Pages 132-133



**Construction**  
Pages 134-135



**Wet Environment**  
Pages 136-137



**Aggregate/Mining**  
Pages 138-139

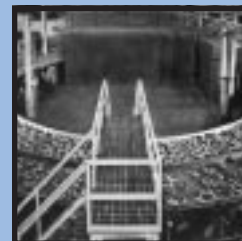

**Eccentric Drives**  
Pages 140-141



**Mixers**  
Pages 142-143

Solutions by  
**CUSTOMIZATION  
AND  
MADE TO ORDER  
PRODUCTS**

**Contact Seal ProGard Seal SafeGard Seal UltraGard Seal**

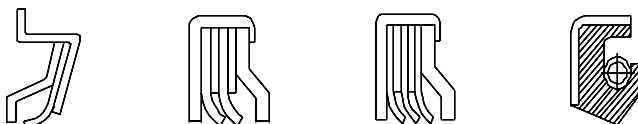

# SEALMASTER®

**MOUNTED BALL BEARINGS...  
THE GOLD STANDARD**

*"GOOD AS GOLD...  
NO EQUAL!"*

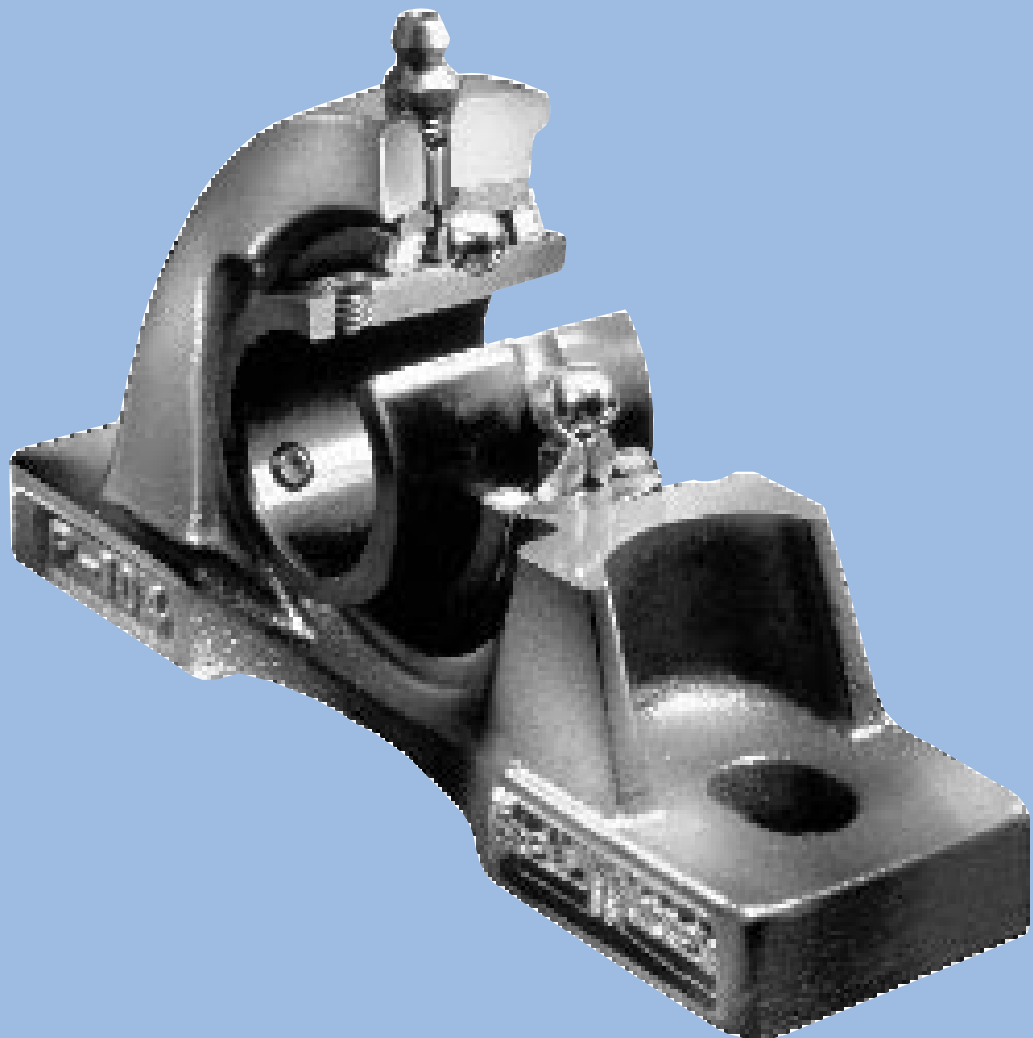

# TABLE OF CONTENTS



	Page Number
Pictorial Index .....	10-13
<b>Gold Line Standard Description Information</b> .....	14-19
<b>Standard Duty Specifications and Dimensions</b> .....	20-44
<b>Pillow Blocks</b>	
NP Series-High Base, Setscrew Locking .....	20
NPL Series-Low Base, Setscrew Locking .....	21
NPD Series-Double Lock, Setscrew Locking .....	22
TB Series-Tapped Base, Setscrew Locking .....	23
SP Series-Heavy Duty Housing, Setscrew Locking .....	24
SPD Series-Double Lock, Setscrew Locking .....	25
<b>Flange Units</b>	
SFT Series-Two Bolt Flange, Setscrew Locking .....	26
FB Series-Three Bolt Flange, Setscrew Locking .....	27
SF Series-Four Bolt Flange, Setscrew Locking .....	28
<b>Cartridge Units</b>	
SFC Series-Flange Cartridge, Setscrew Locking .....	29
SC Series-Cylindrical Cartridge, Setscrew Locking .....	33
<b>Hanger Bearings</b>	
SEHB Series-Eccentric Drive, Setscrew Locking .....	30
SCHB Series-Screw Conveyor, Setscrew Locking .....	31
<b>Rubber Mounted Stamped Steel Housing Units</b>	
SRP Series-Pillow Block, Setscrew Locking .....	34
SRF Series-Flange Block, Setscrew Locking .....	34
SRC Series-Cartridge Unit, Setscrew Locking .....	35
RB Series-Bearing Assemblies .....	35
<b>Take Up Units</b>	
ST Series-Take Up Units, Setscrew Locking .....	32
STH Series-Take Up Frame and Units Style "H" Steel Frame, Setscrew Locking .....	36-37
NPG & SPG Series-Style "G" Protected Screw Take Up Frame and Units .....	38-39
<b>Textile Bearings</b>	
TXP Series-Eccentric Locking, Fixed .....	40
ETXP Series-Eccentric Locking, Expansion .....	40
<b>Inserts</b>	
ER Series-Style "A" Extended Inner Ring Assemblies .....	41
AR Series-Expansion Units, Setscrew Locking .....	42
Standard Duty Series-Single Lock .....	43
Standard Duty Series-Double Lock .....	44
<b>Load Ratings - Normal Duty</b> .....	45
<b>Gold Line Medium Duty Description Information</b> .....	46
<b>Medium Duty Specifications and Dimensions</b> .....	47-61
<b>Pillow Blocks</b>	
MP Series-Two Bolt Base, Setscrew Locking .....	47
EMP Series-Expansion Type, Setscrew Locking .....	48
MPD Series-Two Bolt Base, Double Lock, Setscrew Locking .....	49
SPM Series-Two Bolt Base, Setscrew Locking .....	50
MFP Series-Four Bolt Base, Setscrew Locking .....	51
MSPD Series-Two Bolt Base, Double Lock, Setscrew Locking .....	52
MSFPD Series-Four Bolt Base, Double Lock, Setscrew Locking .....	53
<b>Flange Units</b>	
MSFT Series-Two Bolt Flange, Setscrew Locking .....	54
MSF Series-Four Bolt Flange, Setscrew Locking .....	55
<b>Cartridge Units</b>	
MFC Series-Flange Cartridge, Setscrew Locking .....	56
MSC Series-Cylindrical Cartridge, Setscrew Locking .....	57
<b>Take Up Units</b>	
MST Series-Take Up Units, Setscrew Locking .....	58
<b>Inserts</b>	
AR Series-Expansion Units, Setscrew Locking .....	59
Medium Duty Series-Single Lock .....	60
Medium Duty Series-Double Lock .....	61
<b>Load Ratings - Medium Duty</b> .....	62
<b>Gold Line SKWEZLOC Description Information</b> .....	64-68
<b>Standard Duty Specifications and Dimensions</b> .....	69-76
<b>Load Ratings Standard Duty</b> .....	77
<b>Medium Duty Specifications and Dimensions</b> .....	79-83
<b>Load Ratings Medium Duty</b> .....	84
<b>Gold Line Custom Bearings - Featured Products</b> .....	
Hard Metric SKWEZLOC .....	85
Beverage Bearings .....	86-87
Corrosion-Resistant CR Duty Bearings .....	88-89
High Temperature HF/HFT Furnace Bearings .....	90-91
Featured Products Dimensions .....	92-93
<b>Application Problem Solvers</b> .....	129-143

















# SEALMASTER® MOUNTED BALL BEARINGS

STANDARD DUTY SERIES WITH SETSCREW LOCK		Housing Configuration	Lock	Available Bore Sizes (Inches)	Available Bore Sizes (Metric)	Other Important Features	Selection Factors	Application Information
	<b>NP</b> Dimensional Data See Page 20	High Base Pillow Block	Single	1/2 - 27/16	20-60	Most widely used normal duty pillow block with high base to shaft centerline dimensions.		
	<b>NPL</b> Dimensional Data See Page 21	Low Base Pillow Block	Single	1/2 - 27/16	20-60	Generally used where low shaft to center dimensions exist.		
	<b>SP</b> Dimensional Data See Page 24	Heavy Housing Pillow Block	Single	13/16 - 37/16	25-80	Interchanges shaft to centerline and bolt hole dimensions with other competitive designs.		
	<b>NPD</b> Dimensional Data See Page 22	High Base Pillow Block	Double	7/8 - 27/16	*	Normal duty pillow block with extended inner race and dual locking setscrews.		
	<b>SPD</b> Dimensional Data See Page 25	Heavy Housing Pillow Block	Double	7/8 - 33/16	*	Same as "SP" except double extended inner race and dual locking setscrews.		
	<b>TB</b> Dimensional Data See Page 23	Tapped Base Pillow Block	Single	1/2 - 2	20-50	Tapped base units are well suited for applications where shafts are very close together.		
	<b>SF</b> Dimensional Data See Page 28	Four Bolt Flange Block	Single	1/2 - 215/16	20-75	Designed for flush mounting with machined bases and four bolt holes.		
	<b>SFT</b> Dimensional Data See Page 26	Two Bolt Flange Block	Single	1/2 - 23/16	20-55	Designed for flush mounting with machined bases for light loads and two bolt holes.		
	<b>FB</b> Dimensional Data See Page 27	High Bracket Flange Block	Single	1/2 - 2	20-50	Narrow housing with three bolt holes on one side of the housing. Best used in very tight spaces & tail pulleys.		
	<b>SFC</b> Dimensional Data See Page 29	Cartridge Flange Block	Single	1 1/8 - 33/16	30-80	Four bolt flange with a round piloted surface extended from the mounting service. Designed for heavy loads, vibrating loads or shock loads.		
	<b>SC</b> Dimensional Data See Page 33	Cylindrical Cartridge	Single	1/2 - 215/16	20-75	Cartridge units are similar to flange units. The most noticeable difference is that they are designed to be mounted in a customer's housing.		
	<b>SEHB</b> Dimensional Data See Page 30	Eccentric Drive Hangar Brgs.	Single	15/16 - 4	25-100	A Hangar type bearing for eccentric loads with an external lube fitting.		
	<b>SCHB</b> Dimensional Data See Page 31	Screw Conveyor Brgs.	Single	15/16 - 4	25-100	Designed for screw conveyors with lube capabilities thru the mounting pipe.		
	<b>ST</b> Dimensional Data See Page 32	Wide Slot Take Ups	Single	1/2 - 37/16	20-80	Standard take ups are used with a fabricated frame for shaft adjustment.		
	<b>NPG &amp; SPG</b> Dimensional Data See Page 38-39	Unit & Frame Take Ups	Single	7/8 - 215/16	25-75	Available with standard pillow blocks and protected take up screws to adjust parallel shafts.		
	<b>STH</b> Dimensional Data See Page 36-37	Unit & Frame Take Ups	Single	7/8 - 215/16	25-75	Wide slot take up frame including standard take up unit.		















\* Consult Sealmaster for more information.

# TYPE, SIZES, AVAILABILITY, SELECTION FACTORS

STANDARD DUTY SERIES WITH SETSCREW LOCK (Cont'd.)		Housing Configuration	Lock	Available Bore Sizes (Inches)	Available Bore Sizes (Metric)	Other Important Features	Selection Factors	Application Information
	<b>INSERT</b> Dimensional Data See Page 43	Inserts	Single	1/2 - 3 1/2	20-90	Designed for replacement in all housed units for both normal and medium duty applications.		
	<b>INSERT</b> Dimensional Data See Page 44	Inserts	Double	7/8 - 3 1/2	*	Designed for replacement in all housed units for both normal and medium duty applications.		
	<b>ER</b> Dimensional Data See Page 41	Style "A" Inserts	Single	1/2 - 4	20-80	Cylindrical O.D. designed to mount in customer's housing.		
	<b>AR</b> Dimensional Data See Page 42	Expansion Inserts	Single	1/2 - 3 1/2	20-90	Replacement insert for expansion type units.		
STANDARD DUTY SERIES WITH SKWEZLOC		Housing Configuration	Lock	Available Bore Sizes (Inches)	Available Bore Sizes (Metric)	Other Important Features	Selection Factors	Application Information
	<b>NP-T</b> Dimensional Data See Page 69	High Base Pillow Block	Single	3/4 - 2 15/16	See page 85	Most widely used normal duty pillow block with high base to shaft centerline dimensions.		
	<b>NPL-T</b> Dimensional Data See Page 69	Low Base Pillow Block	Single	3/4 - 2 15/16	See page 85	Generally used where low shaft to center dimensions exist.		
	<b>SP-T</b> Dimensional Data See Page 70	Heavy Housing Pillow Block	Single	1 3/16 - 3 7/16	*	Interchanges shaft to centerline and bolt hole dimensions with other competitive designs.		
	<b>TB-T</b> Dimensional Data See Page 71	Tapped Base Pillow Block	Single	1 5/16 - 2	See page 85	Tapped base units are well suited for applications where shafts are very close together.		
	<b>TFT-T</b> Dimensional Data See Page 71	Two Bolt Flange Block	Single	1 5/16 - 1 7/16	*	Two bolt flange with close bolt centers. Designed for Air Handling applications. Raised back face.		
	<b>SF-T</b> Dimensional Data See Page 72	Four Bolt Flange Block	Single	3/4 - 2 7/16	See page 85	Designed for flush mounting with machined bases and four bolt holes.		
	<b>SFT-T</b> Dimensional Data See Page 72	Two Bolt Flange Block	Single	3/4 - 2 7/16	See page 85	Designed for flush mounting with machined bases for light loads and two bolt holes.		
	<b>FB-T</b> Dimensional Data See Page 74	Bracket Flange Block	Single	1/2 - 2	See page 85	Narrow housing with three bolt holes on one side of the housing. Best used in very tight spaces & tail pulleys.		
	<b>SFC-T</b> Dimensional Data See Page 73	Cartridge Flange Block	Single	1 1/8 - 2 7/16	See page 85	Four bolt flange with a round piloted surface extended from the mounting service. Designed for heavy loads, vibrating loads or shock loads.		
	<b>SC-T</b> Dimensional Data See Page 73	Cylindrical Cartridge	Single	1 5/16 - 2 7/16	See page 85	Cartridge units are similar to flange units. The most noticeable difference is that they are designed to be mounted in a customer's housing.		





\* Consult Sealmaster for more information.









# SEALMASTER® MOUNTED BALL BEARINGS

STANDARD DUTY SERIES WITH SKWEZLOC (Cont'd.)		Housing Configuration	Lock	Available Bore Sizes (Inches)	Available Bore Sizes (Metric)	Other Important Features	Selection Factors	Application Information
	<b>ST-T</b> Dimensional Data See Page 74	Unit Take Ups	Single	1/2 - 27/16	*	Standard take ups are used with a fabricated frame for shaft adjustment.		
	<b>INSERT</b> Dimensional Data See Page 76	Inserts	Single	3/4 - 27/16	See page 85	Designed for replacement in all housed units for both normal and medium duty applications.		
	<b>ER-T</b> Dimensional Data See Page 75	Style "A" Inserts	Single	3/4 - 27/16	See page 85	Cylindrical O.D. designed to mount in customer's housing. Used primarily in the printing industry.		
	<b>AR-T</b> Dimensional Data See Page 76	Expansion Inserts	Single	3/4 - 27/16	See page 85	Replacement insert for expansion type units.		
MEDIUM DUTY SERIES WITH SETSCREW		Housing Configuration	Lock	Available Bore Sizes (Inches)	Available Bore Sizes (Metric)	Other Important Features	Selection Factors	Application Information
	<b>MP</b> Dimensional Data See Page 47	Two Bolt Pillow Block	Single	15/16 - 4	25-100	Generally used in medium to heavy duty applications. Dimensionally interchangeable with many competitive units.		
	<b>MPD</b> Dimensional Data See Page 49	Two Bolt Pillow Block	Double	15/16 - 4	*	Medium duty pillow block with an extended inner race and dual setscrew locking.		
	<b>EMP</b> Dimensional Data See Page 48	Expansion Pillow Block	Single	15/16 - 4	25-80	Designed for medium duty applications where shaft expansion exists.		
	<b>MFP</b> Dimensional Data See Page 51	Four Bolt Pillow Block	Single	115/16 - 415/16	50-100	Large bore medium duty pillow block with four bolt base. Excellent for heavy shock loads.		
	<b>MSPD</b> Dimensional Data See Page 52	Two Bolt Pillow Block	Double	111/16 - 415/16	*	High base to center dimensions with extended inner race and dual locking setscrews.		
	<b>MSFPD</b> Dimensional Data See Page 53	Four Bolt Pillow Block	Double	115/16 - 415/16	*	Same as "MSPD" with four bolt base for heavy shock loads.		
	<b>SPM</b> Dimensional Data See Page 50	Two Bolt Pillow Block	Single	13/16 - 21/2	*	Designed for interchangeability with competitive units.		
	<b>MSF</b> Dimensional Data See Page 55	Four Bolt Flange Block	Single	15/16 - 415/16	25-100	For industrial machinery with medium to heavy loads and four bolt face mounting.		
	<b>MSFT</b> Dimensional Data See Page 54	Two Bolt Flange Block	Single	15/16 - 2	25-50	Medium duty two bolt flange for face mounting.		
	<b>MSC</b> Dimensional Data See Page 57	Cylindrical Cartridge	Single	15/16 - 4	25-100	Designed to fit in customer's housing and will handle medium loads and speeds.		
	<b>MFC</b> Dimensional Data See Page 56	Flange Cartridge	Single	15/16 - 4	25-100	Pilot dimension fits in customer's machine.		

\* Consult Sealmaster for more information.

# TYPE, SIZES, AVAILABILITY, SELECTION FACTORS

MEDIUM DUTY SERIES WITH SETSCREW (Cont'd.)		Housing Configuration	Lock	Available Bore Sizes (Inches)	Available Bore Sizes (Metric)	Other Important Features	Selection Factors	Application Information
	<b>MST</b> Dimensional Data See Page 58	Unit Take Up	Single	1 <sup>5</sup> / <sub>16</sub> - 4	25-100	Wide slot medium duty take up used to move or adjust shafts.		
	<b>INSERT</b> Dimensional Data See Page 60	Inserts	Single	1 <sup>5</sup> / <sub>16</sub> - 4	25-100	Designed for replacement in all housed units for both normal and medium duty applications.		
	<b>INSERT</b> Dimensional Data See Page 61	Inserts	Double	1 <sup>5</sup> / <sub>16</sub> - 4 <sup>15</sup> / <sub>16</sub>	*	Designed for replacement in all housed units for both normal and medium duty applications.		
	<b>AR</b> Dimensional Data See Page 59	Expansion Inserts	Single	1 <sup>5</sup> / <sub>16</sub> - 4	25-100	Replacement insert for expansion type units.		

MEDIUM DUTY SERIES WITH SKWEZLOC		Housing Configuration	Lock	Available Bore Sizes (Inches)	Available Bore Sizes (Metric)	Other Important Features	Selection Factors	Application Information
	<b>MP-T</b> Dimensional Data See Page 79	Two Bolt Pillow Block	Single	1 - 2 <sup>1</sup> / <sub>4</sub>	*	Generally used in medium to heavy duty applications. Dimensionally interchangeable with many competitive units.		
	<b>EMP-T</b> Dimensional Data See Page 79	Expansion Pillow Block	Single	1 <sup>5</sup> / <sub>16</sub> - 2 <sup>7</sup> / <sub>16</sub>	*	Designed for medium duty applications where shaft expansion exists.		
	<b>MSF-T</b> Dimensional Data See Page 80	Four Bolt Flange Block	Single	1 - 2 <sup>1</sup> / <sub>4</sub>	*	For industrial machinery with medium to heavy loads and four bolt face mounting.		
	<b>MSFT-T</b> Dimensional Data See Page 80	Two Bolt Flange Block	Single	1 - 2	*	Medium duty two bolt flange for face mounting.		
	<b>MSC-T</b> Dimensional Data See Page 81	Cylindrical Cartridge	Single	1 - 2 <sup>1</sup> / <sub>4</sub>	*	Designed to fit in customer's housing and will handle medium loads and speeds.		
	<b>MFC-T</b> Dimensional Data See Page 81	Flange Cartridge	Single	1 - 2 <sup>1</sup> / <sub>4</sub>	*	Pilot dimension fits in customer's machine.		
	<b>MST-T</b> Dimensional Data See Page 82	Unit Take Up	Single	1 - 2 <sup>1</sup> / <sub>4</sub>	*	Wide slot medium duty take up used to move or adjust shafts.		
	<b>INSERT</b> Dimensional Data See Page 83	Inserts	Single	1 - 2 <sup>3</sup> / <sub>16</sub>	*	Designed for replacement in all housed units for both normal and medium duty applications.		
	<b>AR-T</b> Dimensional Data See Page 83	Expansion Inserts	Single	1 - 2 <sup>3</sup> / <sub>16</sub>	*	Replacement insert for expansion type units.		

\* Consult Sealmaster for more information.

# THE GOLD STANDARD IS THE STANDARD OF SUPERIOR DESIGN

## EXTRA WIDE INNER AND OUTER RACES...

provide better stability on the shaft and in the housing, plus extra grease capacity.

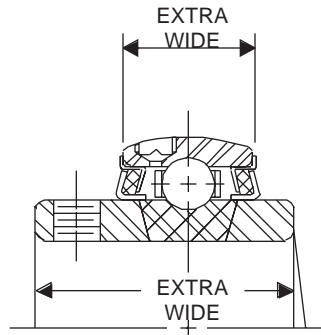

## PATENTED FELT LABYRINTH SEAL...

with rotating flinger directs contamination away from the sealing surfaces. The felt design provides a tight labyrinth seal which retains grease and acts as a filter to exclude foreign material. The design operates with less drag and less heat generation than rubber contact seals. Alternate seals are available.

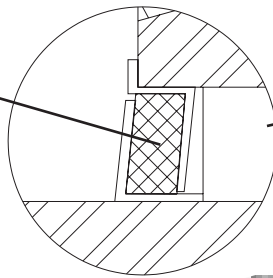

## ZONE HARDENED INNER RACE...

provides fully hardened ball path while leaving race extension unhardened, allowing for exceptional control of setscrew holding power. Raceways are ground and honed to ensure longer life and quieter operation.

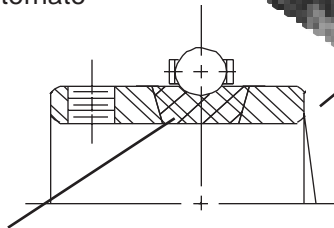

Ground thread setscrews with faceted cup points.



## SPECIALY-DESIGNED DIAMOND POINT CUP, GROUND THREAD SETSCREWS AT 120°...

deliver superior shaft holding power with less race distortion than any other setscrew design.

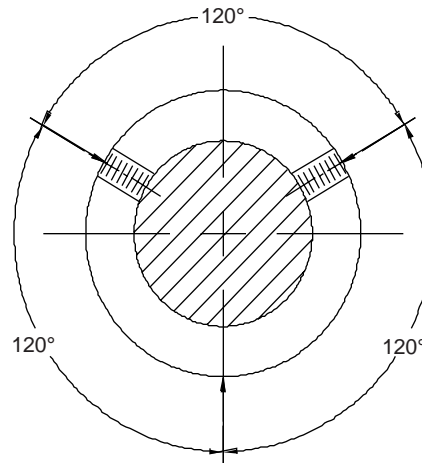

Balanced 3-point contact

AVAILABLE IN THE INDUSTRY'S WIDEST BORE RANGE

FROM 1/2" THROUGH 4 15/16"

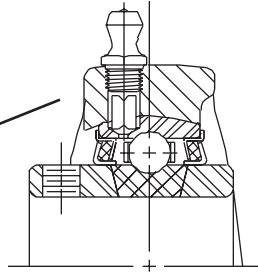

**EXCLUSIVE  
LOCKING PIN AND  
DIMPLE SYSTEM...**

prevents outer race rotation, allows a full  $\pm 2^\circ$  misalignment and ensures direct lubrication into the bearing.

**INNER AND OUTER RACES OF  
HIGH QUALITY 52100  
VACUUM  
DEGASSED STEEL...**

**(HIGH CARBON, CHROME ALLOY)**  
ensure fatigue life reliability.

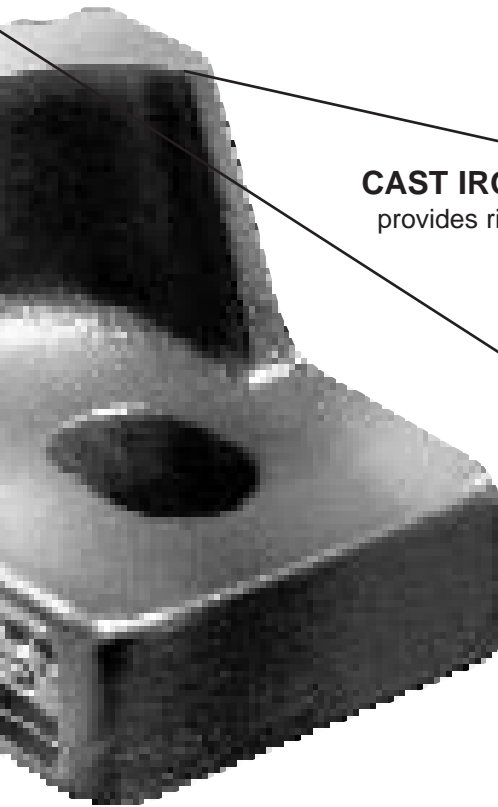

**SOLID BASE  
CAST IRON HOUSING...**

provides rigidity and vibration damping.

**OTHER  
QUALITY FEATURES  
AND OPTIONS HELP  
TO MAINTAIN  
THE HIGHEST  
STANDARDS**

**CORROSION-RESISTANT COATING**

All exposed inner and outer ring surfaces are specially treated with black oxide for oil affinity and corrosion resistance. This is standard on all Gold Line bearings at no extra cost. (Note that competitors charge extra for this protective coating.)

**PERMANENT NAMEPLATE**

A metal nameplate containing the bearing's unit number and shaft size is firmly secured to each mounted bearing unit for long life and positive identification.

**MODIFICATIONS AND OPTIONS  
INCREASE APPLICATION VERSATILITY**

**SEALMASTER** bearing engineers welcome the opportunity to customize the Gold Line with modifications and optional features.

**UNIQUE LAND RIDING  
METAL BALL RETAINER...**

minimizes friction and provides maximum grease circulation. Retainer is designed to "float" on the ground extension (or lands) of the outer ring while spacing the balls precisely for more even load distribution. This minimizes wear on both balls and retainer, while maximizing stability, especially important in applications involving vibration, shock loading or high operating speeds. For applications involving high temperatures,  $+200^\circ\text{F}$ , land riding brass retainers are available.





# DIFFERENT...BY DESIGN!

## Locking Pin and Dimple Direct Lubrication & Outer Ring Antirotation...

The Sealmaster exclusive locking pin and dimple system provides direct lubrication flow into the bearing chamber. The locking pin extends from directly beneath the zerk fitting into a dimple drilled into an extra wide outer race.

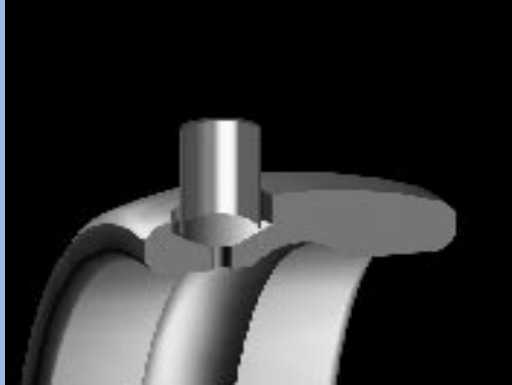

The floor of the dimple is also the grease port of entry to the ball path. This design minimizes the chances of contaminants or oxidized grease from inhibiting relubrication. The locking pin also properly positions the bearing insert within the housing configuration and allows for  $\pm 2$  degrees misalignment. Further, the locking pin prevents outer race rotation (sometimes referred to as "creep"). In other bearing designs where outer race rotation often occurs, the lubrication system may be compromised and the user's ability to re-lubricate the bearing is diminished. The Sealmaster locking pin and dimple system is a most important feature contributing to longer useful bearing life...available only on *Sealmaster Gold...Different by Design!*

## Extra Wide Outer Race...

Sealmaster has the industry's widest outer race. Ranging from 13% to 26% wider than competitive units. This feature provides a significant surface area for the absorption of shock loads. More importantly, the wide race creates a large internal grease chamber. As previously mentioned, lubrication issues are the leading causes of bearing failures. The extra grease extends useful bearing life. **Better by design...No Equal!**



## Extra Wide Inner Race...

Sealmaster long inner race provides greater surface contact with the shaft for stability and wide load distribution. This is critical on applications where vibration, shock, and reciprocating motion exist.

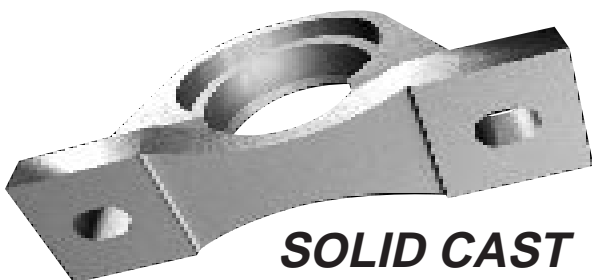
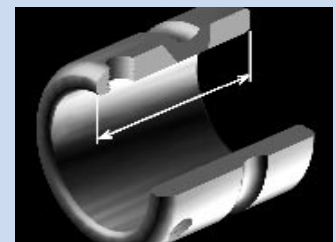

**SOLID CAST  
IRON HOUSING**

## Rugged cast iron housings...

Solid bases are standard on Sealmaster Gold ball bearing pillow blocks. The rugged solid face absorbs shock loads and distributes forces throughout the housing. This construction is also key on mounting surfaces such as sheet metal where "buckling" of the structure may occur when hollow foot castings are used. We encourage you to visually inspect the difference! **Extra Tough...More Value!**



# SEALMASTER® MOUNTED BALL BEARINGS



## PATENTED FELT LINED FLINGER



The Sealmaster labyrinth felt seal (our name Sealmaster means "Master Seal") is the industry benchmark for keeping contaminants out and lubrication in! The design incorporates a series of passageways with a highly effective filtering media that together block the ingress of contaminants and allow for the purging of oxidized grease during re-lubrication. Protective metal flingers are primary factors in seal performance. The inner flinger is pressed into the outer race and is a stationary foundation for the sealing system. The outer flinger, the first barrier to contaminant entry, is attached to the inner race and therefore rotates with the shaft. The rotation of the outer flinger offers two significant benefits. The first is the creation of a centrifugal force that repels debris by "slinging" it away from the seal area. The second is an extension of the flinger internally into the bearing chamber that initiates a vortex that churns the lubricant back toward the ball path where it is needed most! **Sealmaster's Master Seal is more than a seal...it is an integral part of our bearing system that extends useful bearing life.**

## 120° SET SCREW POSITION AND PRECISION GROUND DIAMOND FACETED SET SCREWS



Roundness of the inner race is uniformly accepted as a critical factor effecting overall bearing performance. Sealmaster set screws located 120° apart provide for a balanced 3-point contact. This evenly positioned shaft lock design is particularly important in high speed applications where any eccentricity is magnified. **See pages 64-68 for information about Sealmaster Skwezloc concentric locking device...the Sealmaster ultimate in concentricity and true rolling motion.**

Every component of the Sealmaster Gold design has more than one purpose. Sealmaster Gold Ball Bearings come standard with precision ground (not rolled) setscrews that mate effectively with our inner race post heat treat drilled and tapped setscrew holes. These premium setscrews also incorporate a diamond faceted point (more effective than cup-point or knurled) that tightly secures the setscrews to the shaft and resists any reverse rotation or backout.

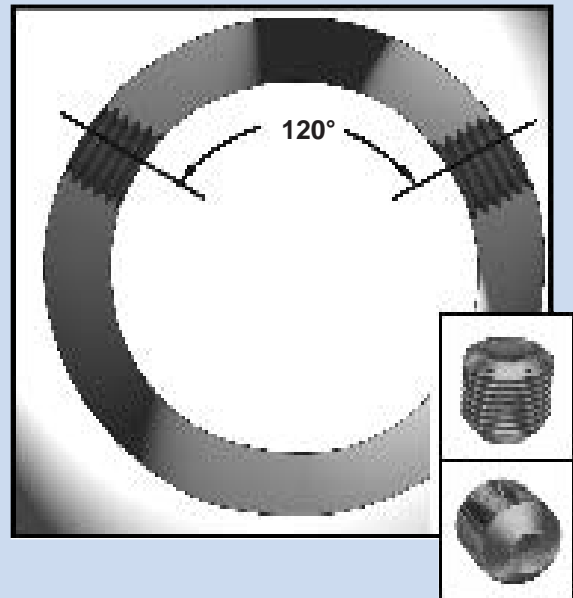

## BLACK OXIDE CORROSION RESISTANT RACES

Sealmaster inner and outer races and seal flingers are processed through an alkaline solution. This chemically primes the surface of the steel for better lubrication retention and corrosion resistance. Unlike many competitors Sealmaster provides black oxide as a standard feature. **More Value...No Added Cost!**

# DIFFERENT...BY DESIGN!

## UNIQUE METAL LANDRIDING RETAINER...

Another exclusive feature is the Sealmaster metal land riding retainer. The retainer may be considered the "heart" of the bearing and the Sealmaster retainer is particularly strong. The retainer is metal instead of nylon as found in other designs. This strength is especially important under heavily loaded situations where the accurate spacing of the bearing balls is critical. Further, the land riding design allows for free 360 degree circulation of lubricant around the balls and into the ball paths that contributes to higher speed capability. Another benefit is the collection of grease in the retainer's recessed ball pockets that allows for a gradual release of oil as needed. The Sealmaster metal land riding retainer is key to cooler running, longer grease life, and high speed capability. **More Value...Different by Design!**



**MAXIMUM  
USEFUL  
BEARING  
LIFE**

**DIFFERENTRATED  
LUBRICATION  
AND  
SEALING SYSTEMS**



## ZONE HARDENED INNER RACE...

Sealmaster incorporates a unique heat treat process that hardens the inner race only where it is needed...underneath the ball path! This permits the extended portion of the inner race to remain unhardened and allows for tapping set screws holes after heat treat. This process does not distort the tapped threads in the set screw holes that creates a tightly meshed system and an effective, secure lock. **Excellent hold on the Shaft!**

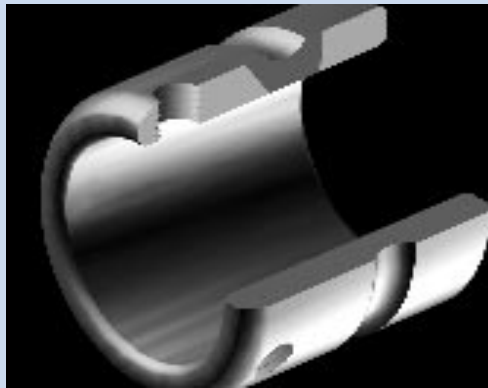

**SUPERIOR  
SHAFT STABILITY**



## PERMANENT METAL NAMEPLATE...

Sealmaster takes pride in the details. The Sealmaster metal nameplate is an additional example of outstanding value. Each metal name plate is riveted to the housing and is able to withstand the many expected years of bearing operation. **Good As Gold...with No Equal!**



**GOOD AS  
GOLD...**

**NO EQUAL!**

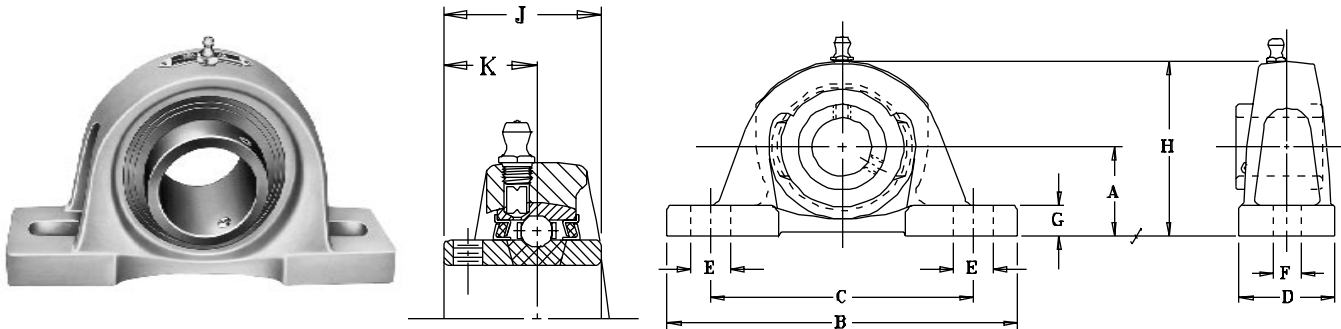

## NP Series Standard Duty Pillow Blocks...Setscrew Locking

SHAFT DIAM.	PART NO.	BRG. NO.	Dimensions in Inches											BOLT SIZE IN.	UNIT WT.
			A	B	C		D	E	F	G	H	J	K		
IN	MM				MIN.	MAX.									
1/2 9/16 5/8 11/16	NP-8 NP-9 NP-10 NP-11	2-08 2-09 2-010 2-011	1 3/16	5	3 3/8	4 1/8	1 1/2	3/4	7/16	1/2	2 7/16	1 7/32	23/32	3/8	1.7
3/4 20	NP-12 NP-204	2-012 5204	1 5/16	5	3 3/8	4 1/8	1 1/2	3/4	7/16	1/2	2 9/16	1 7/32	23/32	3/8	1.9
13/16 7/8 15/16 1	NP-13 NP-14 NP-15 NP-16 NP-205	2-013 2-014 2-015 2-1 5205	1 7/16	5 1/2	3 7/8	4 3/8	1 1/2	5/8	7/16	1/2	2 13/16	1 3/8	13/16	3/8	2.2
1 1/16 1 1/8 1 3/16 1 1/4	NP-17 NP-18 NP-19 NP-20R NP-206	2-11 2-12 2-13 1-14 5206	1 11/16	6 1/2	4 7/16	5 1/16	1 7/8	13/16	9/16	9/16	3 3/8	1 1/2	7/8	1/2	3.6
1 1/4 1 5/16 1 3/8 1 7/16	NP-20 NP-21 NP-22 NP-23 NP-207	2-14 2-15 2-16 2-17 5207	1 7/8	6 9/16	4 11/16	5 5/16	1 7/8	13/16	9/16	5/8	3 3/4	1 11/16	1	1/2	4.5
1 1/2 1 9/16	NP-24 NP-25 NP-208	2-18 2-19 5208	1 15/16	7 1/4	4 7/8	5 7/8	2 1/8	1	9/16	11/16	3 15/16	1 15/16	1 3/16	1/2	5.7
1 5/8 1 11/16 1 3/4	NP-26 NP-27 NP-28 NP-209	2-110 2-111 2-112 5209	2 1/8	7 1/2	5 7/16	6 1/16	2 1/8	13/16	9/16	11/16	4 1/4	1 15/16	1 3/16	1/2	6.5
1 13/16 1 7/8 1 15/16 2	NP-29 NP-30 NP-31 NP-32R NP-210	2-113 2-114 2-115 1-2 5210	2 1/4	8 1/8	6	6 1/2	2 3/8	7/8	11/16	3/4	4 9/16	2 1/32	1 9/32	5/8	7.9
2 2 1/8 2 3/16	NP-32 NP-34 NP-35 NP-211	2-2 2-22 2-23 5211	2 1/2	8 5/8	6 1/2	7	2 3/8	7/8	11/16	3/4	5	2 3/16	1 5/16	5/8	9.7
2 1/4 2 3/8 2 7/16	NP-36 NP-38 NP-39 NP-212	2-24 2-26 2-27 5212	2 3/4	9 1/2	6 7/8	7 5/8	2 3/4	1	11/16	7/8	5 9/16	2 9/16	1 9/16	5/8	13.7

For Load Ratings, see page 45.

For Standard Duty Bearing Inserts-Single Lock, see page 43.



**Single Lip Contact Seal**  
Available on all sizes. Recommended where moisture conditions prevail.  
To specify, add suffix "C" (NP-16C).



**Felt Seal Standard**  
Positive sealing for low, medium, and high speed operation.

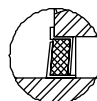

**Hi-Temp Seal**  
Available as an option where operating temperatures are in 250-400° range.  
(See seal options on page 188.)

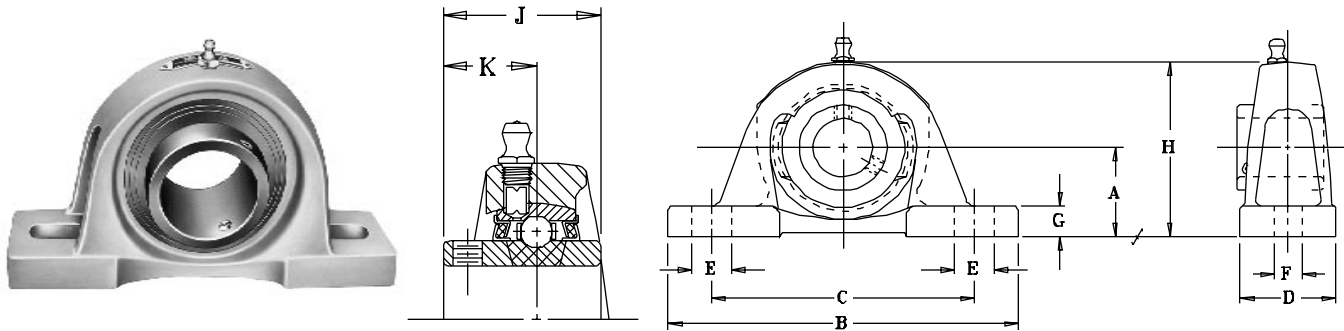

## NPL Series Standard Duty Pillow Blocks...Setscrew Locking

SHAFT DIAM.	PART NO.	BRG. NO.	Dimensions in Inches											BOLT SIZE IN.	UNIT WT.
			A	B	C		D	E	F	G	H	J	K		
IN	MM				MIN.	MAX.									
1/2 9/16 5/8 11/16	NPL-8 NPL-9 NPL-10 NPL-11	2-08 2-09 2-010 2-011	1 1/16	5	3 3/8	4 1/8	1 1/2	3/4	7/16	3/8	2 5/16	1 7/32	23/32	3/8	1.7
3/4 20	NPL-12 NPL-204	2-012 5204	1 1/4	5	3 3/8	4 1/8	1 1/2	3/4	7/16	7/16	2 1/2	1 7/32	23/32	3/8	1.7
13/16 7/8 15/16 1	NPL-13 NPL-14 NPL-15 NPL-16 NPL-205	2-013 2-014 2-015 2-1 5205	1 5/16	5 1/2	3 7/8	4 3/8	1 1/2	5/8	7/16	1/2	2 11/16	1 3/8	13/16	3/8	2.0
1 1/16 1 1/8 1 3/16 1 1/4 30	NPL-17 NPL-18 NPL-19 NPL-20R NPL-206	2-11 2-12 2-13 1-14 5206	1 9/16	6 1/2	4 7/16	5 1/16	1 7/8	13/16	9/16	7/16	3 1/4	1 1/2	7/8	1/2	3.6
1 1/4 1 5/16 1 3/8 1 7/16 35	NPL-20 NPL-21 NPL-22 NPL-23 NPL-207	2-14 2-15 2-16 2-17 5207	1 13/16	6 9/16	4 11/16	5 5/16	1 7/8	13/16	9/16	9/16	3 11/16	1 11/16	1	1/2	4.4
1 1/2 1 9/16 40	NPL-24 NPL-25 NPL-208	2-18 2-19 5208	1 15/16	7 1/4	4 7/8	5 7/8	2 1/8	1	9/16	11/16	3 15/16	1 15/16	1 3/16	1/2	5.7
1 5/8 1 11/16 1 3/4 45	NPL-26 NPL-27 NPL-28 NPL-209	2-110 2-111 2-112 5209	2 1/16	7 1/2	5 7/16	6 1/16	2 1/8	13/16	9/16	5/8	4 3/16	1 15/16	1 3/16	1/2	6.2
1 13/16 1 7/8 1 15/16 2	NPL-29 NPL-30 NPL-31 NPL-32R NPL-210	2-113 2-114 2-115 1-2 5210	2 3/16	8 1/8	6	6 1/2	2 3/8	7/8	11/16	11/16	4 1/2	2 1/32	1 9/32	5/8	7.8
2 2 1/8 2 3/16 55	NPL-32 NPL-34 NPL-35 NPL-211	2-2 2-22 2-23 5211	2 7/16	8 5/8	6 1/2	7	2 3/8	7/8	11/16	11/16	4 15/16	2 3/16	1 5/16	5/8	9.6
2 1/4 2 3/8 2 7/16 60	NPL-36 NPL-38 NPL-39 NPL-212	2-24 2-26 2-27 5212	2 11/16	9 1/2	6 7/8	7 5/8	2 3/4	1	11/16	13/16	5 1/2	2 9/16	1 9/16	5/8	13.5

For Load Ratings, see page 45.

For Standard Duty Bearing Inserts-Single Lock, see page 43.

See page 20 for seal arrangements.



MOUNTED BALL BEARINGS

**SEALMASTER®**

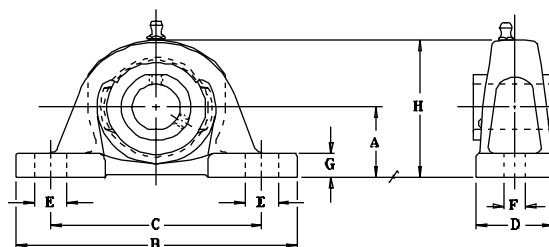
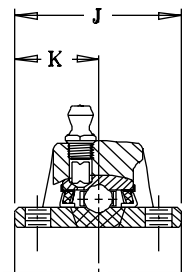

## NPD Series Standard Duty Pillow Blocks with Double Lock...Setscrew Locking

SHAFT DIAM.	PART NO.	BRG. NO.	Dimensions in Inches											BOLT SIZE IN.	UNIT WT.
			A	B	C		D	E	F	G	H	J	K		
IN	MM				MIN.	MAX.									
7/8 15/16 1	NPD-14 NPD-15 NPD-16	2-014D 2-015D 2-1D	1 7/16	5 1/2	3 7/8	4 3/8	1 1/2	5/8	7/16	1/2	2 13/16	1 1/2	3/4	3/8	2.4
1 1/16 1 1/8 1 3/16	NPD-17 NPD-18 NPD-19	2-11D 2-12D 2-13D	1 11/16	6 1/2	4 7/16	5 1/16	1 7/8	13/16	9/16	9/16	3 3/8	1 3/4	7/8	1/2	3.8
1 1/4 1 5/16 1 3/8 1 7/16	NPD-20 NPD-21 NPD-22 NPD-23	2-14D 2-15D 2-16D 2-17D	1 7/8	6 9/16	4 11/16	5 5/16	1 7/8	13/16	9/16	5/8	3 3/4	2	1	1/2	4.7
1 1/2 1 9/16	NPD-24 NPD-25	2-18D 2-19D	1 15/16	7 1/4	4 7/8	5 7/8	2 1/8	1	9/16	11/16	3 15/16	2 5/16	1 5/32	1/2	6.0
1 5/8 1 11/16 1 3/4	NPD-26 NPD-27 NPD-28	2-110D 2-111D 2-112D	2 1/8	7 1/2	5 7/16	6 1/16	2 1/8	13/16	9/16	11/16	4 1/4	2 3/8	1 3/16	1/2	6.5
1 7/8 1 15/16	NPD-30 NPD-31	2-114D 2-115D	2 1/4	8 1/8	6	6 1/2	2 3/8	7/8	11/16	3/4	4 9/16	2 1/2	1 1/4	5/8	8.3
2 2 1/8 2 3/16	NPD-32 NPD-34 NPD-35	2-2D 2-22D 2-23D	2 1/2	8 5/8	6 1/2	7	2 3/8	7/8	11/16	3/4	5	2 5/8	1 5/16	5/8	10.0
2 1/4 2 3/8 2 7/16	NPD-36 NPD-38 NPD-39	2-24D 2-26D 2-27D	2 3/4	9 1/2	6 7/8	7 5/8	2 3/4	1	11/16	7/8	5 9/16	3 1/8	1 9/16	5/8	14.0

For Load Ratings, see page 45.

For Standard Duty Bearing Inserts-Double lock, see page 44.



**Felt Seal Standard**  
Positive sealing for low, medium, and high speed operation.



**Single Lip Contact Seal**  
Available on all sizes. Recommended where moisture conditions prevail.  
To specify, add suffix "C" (NPD-16C).

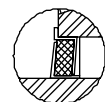

**Hi-Temp Seal**  
Available as an option where operating temperatures are in 250-400° range.  
(See seal options on page 188).

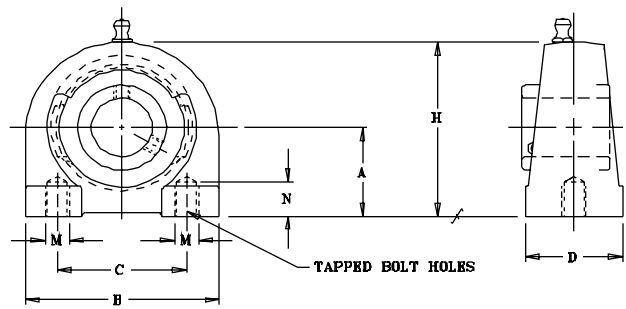
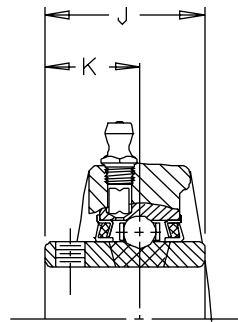

## TB Series Tapped Base Pillow Blocks...Setscrew Locking

SHAFT DIAM. IN MM	PART NO.	BRG. NO.	Dimensions in Inches							N MIN. TAP DEPTH	M BOLT UNC-2B THD	UNIT WT.
			A	B	C	D	H	J	K			
1/2 9/16 5/8 11/16 3/4 20	TB-8 TB-9 TB-10 TB-11 TB-12 TB-204	2-08 2-09 2-010 2-011 2-012 5204	1 5/16	3 1/8	2	1 1/2	2 9/16	1 7/32	23/32	1/2	3/8-16	1.8
13/16 7/8 15/16 1 25	TB-13 TB-14 TB-15 TB-16 TB-205	2-013 2-014 2-015 2-1 5205	1 7/16	3	2	1 1/2	2 13/16	1 3/8	13/16	1/2	3/8-16	2.0
1 1/16 1 1/8 1 3/16 1 1/4 30	TB-17 TB-18 TB-19 TB-20R TB-206	2-11 2-12 2-13 1-14 5206	1 11/16	4	3	1 1/2	3 13/32	1 1/2	7/8	5/8	7/16-14	3.5
1 1/4 1 5/16 1 3/8 1 7/16 35	TB-20 TB-21 TB-22 TB-23 TB-207	2-14 2-15 2-16 2-17 5207	1 7/8	4 1/4	3 1/4	1 7/8	3 3/4	1 11/16	1	3/4	1/2-13	4.5
1 1/2 1 9/16 40	TB-24 TB-25 TB-208	2-18 2-19 5208	1 15/16	4 5/8	3 1/2	1 7/8	3 15/16	1 15/16	1 3/16	3/4	1/2-13	6.0
1 5/8 1 11/16 1 3/4 45	TB-26 TB-27 TB-28 TB-209	2-110 2-111 2-112 5209	2 1/8	5	3 3/4	2	4 1/4	1 15/16	1 3/16	3/4	1/2-13	6.50
1 13/16 1 7/8 1 15/16 2 50	TB-29 TB-30 TB-31 TB-32R TB-210	2-113 2-114 2-115 1-2 5210	2 1/4	5 1/2	4	2	4 5/8	2 1/32	1 9/32	7/8	5/8-11	8.0

For Load Ratings, see page 45.

For Standard Duty Bearing Inserts-Single Lock, see page 43.

See page 22 for seal arrangements.

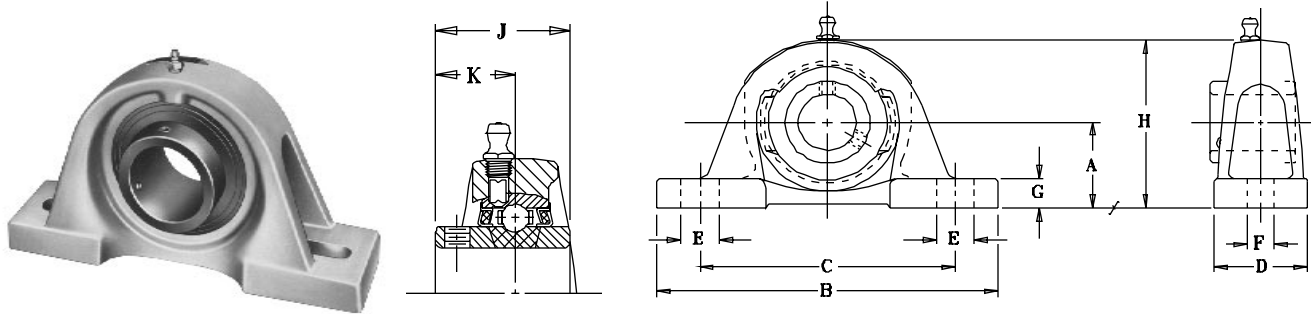

## SP Series Standard Duty Pillow Blocks...Setscrew Locking

SHAFT DIAM.	PART NO.	BRG. NO.	Dimensions in Inches											BOLT SIZE IN.	UNIT WT.
			A	B	C		D	E	F	G	H	J	K		
IN	MM				MIN.	MAX.									
13/16 7/8 15/16 1	SP-13 SP-14 SP-15 SP-16 SP-205	2-013 2-014 2-015 2-1 5205	1 3/4	7	5 1/8	5 5/8	2	3/4	9/16	9/16	3 5/16	1 3/8	13/16	1/2	3.6
1 1/16 1 1/8 1 3/16 1 1/4	SP-17 SP-18 SP-19 SP-20R SP-206	2-11 2-12 2-13 1-14 5206	2	7 1/2	5 3/8	6 1/8	2	7/8	9/16	5/8	3 7/8	1 1/2	7/8	1/2	5.0
1 1/4 1 5/16 1 3/8 1 7/16	SP-20 SP-21 SP-22 SP-23 SP-207	2-14 2-15 2-16 2-17 5207	2 3/8	8 1/4	5 5/8	6 7/8	2 1/4	1 1/4	3/4	3/4	4 1/2	1 11/16	1	5/8	7.0
1 1/2 1 9/16	SP-24 SP-25 SP-208	2-18 2-19 5208	2 5/16	8 1/2	5 7/8	7 1/8	2 3/8	1 1/4	3/4	3/4	4 9/16	1 15/16	1 3/16	5/8	7.6
1 5/8 1 11/16 1 3/4	SP-26 SP-27 SP-28 SP-209	2-110 2-111 2-112 5209	2 3/8	8 3/4	5 7/8	7 1/8	2 3/8	1 1/4	3/4	3/4	4 5/8	1 15/16	1 3/16	5/8	8.1
1 13/16 1 7/8 1 15/16 2	SP-29 SP-30 SP-31 SP-32R SP-210	2-113 2-114 2-115 1-2 5210	2 3/4	10 1/2	6 3/4	8 1/2	2 1/2	1 1/2	3/4	7/8	5 5/16	2 1/32	1 9/32	5/8	11.6
2 2 1/8 2 3/16	SP-32 SP-34 SP-35 SP-211	2-2 2-22 2-23 5211	3 1/8	11 1/4	7 5/8	9 3/8	2 3/4	1 1/2	3/4	7/8	5 15/16	2 3/16	1 5/16	5/8	14.1
2 1/4 2 3/8 2 7/16	SP-36 SP-38 SP-39 SP-212	2-24 2-26 2-27 5212	3 1/8	11 1/2	7 7/8	9 3/8	3	1 1/2	7/8	7/8	6 1/16	2 9/16	1 9/16	3/4	16.5
2 1/2 2 11/16	SP-40 SP-43 SP-214	3-28 2-211 5214	3 3/4	12 5/8	9 3/8	10 5/8	3 3/8	1 3/8	7/8	1	7 1/8	2 3/4	1 11/16	3/4	26.3
2 7/8 2 15/16	SP-46 SP-47 SP-215	2-214 2-215 5215	3 3/4	13	9 1/4	10 3/4	3 3/8	1 1/2	7/8	1	7 3/16	3 1/16	1 3/4	3/4	26.6
3 3 3/16	SP-48 SP-51 SP-216	3-3 2-33 5216	4	14 1/2	10 5/8	12 1/8	3 3/4	1 1/2	7/8	1 1/8	7 13/16	3 1/4	1 15/16	3/4	34.0
3 1/4 3 3/8 3 7/16	SP-52 SP-54 SP-55	2-34 2-36 2-37	4	15	9 5/8	11 7/8	4 1/4	2	1	1 1/4	8 1/16	3 3/8	2 1/32	7/8	42.1

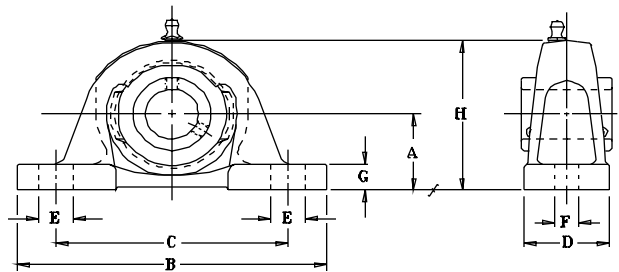
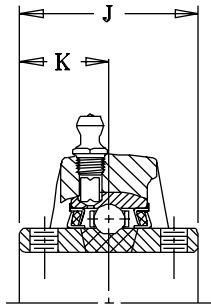

## SPD Series Standard Duty Pillow Blocks with Double Lock...Setscrew Locking

SHAFT DIAM.	PART NO.	BRG. NO.	Dimensions in Inches						BOLT						SIZE IN.	UNIT WT.
			A	B	C		D	E	F	G	H	J	K			
IN	MM				MIN.	MAX.										
7/8 15/16 1	SPD-14 SPD-15 SPD-16	2-014D 2-015D 2-1D	1 3/4	7	5 1/8	5 5/8	2	3/4	9/16	9/16	3 5/16	1 1/2	3/4	1/2	3.6	
1 1/16 1 1/8 1 3/16	SPD-17 SPD-18 SPD-19	2-11D 2-12D 2-13D	2	7 1/2	5 3/8	6 1/8	2	7/8	9/16	5/8	3 7/8	1 3/4	7/8	1/2	5.0	
1 1/4 1 5/16 1 3/8 1 7/16	SPD-20 SPD-21 SPD-22 SPD-23	2-14D 2-15D 2-16D 2-17D	2 3/8	8 1/4	5 5/8	6 7/8	2 1/4	1 1/4	3/4	3/4	4 1/2	2	1	5/8	7.2	
1 1/2 1 9/16	SPD-24 SPD-25	2-18D 2-19D	2 5/16	8 1/2	5 7/8	7 1/8	2 3/8	1 1/4	3/4	3/4	4 9/16	2 5/16	1 5/32	5/8	7.7	
1 5/8 1 11/16 1 3/4	SPD-26 SPD-27 SPD-28	2-110D 2-111D 2-112D	2 3/8	8 3/4	5 7/8	7 1/8	2 3/8	1 1/4	3/4	3/4	4 5/8	2 3/8	1 3/16	5/8	8.3	
1 7/8 1 15/16	SPD-30 SPD-31	2-114D 2-115D	2 3/4	10 1/2	6 3/4	8 1/2	2 1/2	1 1/2	3/4	7/8	5 5/16	2 1/2	1 1/4	5/8	11.6	
2 2 1/8 2 3/16	SPD-32 SPD-34 SPD-35	2-2D 2-22D 2-23D	3 1/8	11 1/4	7 5/8	9 3/8	2 3/4	1 1/2	3/4	7/8	5 15/16	2 5/8	1 5/16	5/8	14.1	
2 1/4 2 3/8 2 7/16	SPD-36 SPD-38 SPD-39	2-24D 2-26D 2-27D	3 1/8	11 1/2	7 7/8	9 3/8	3	1 1/2	7/8	7/8	6 1/16	3 1/8	1 9/16	3/4	17.0	
2 1/2 2 11/16	SPD-40 SPD-43	3-28D 2-211D	3 3/4	12 5/8	9 3/8	10 5/8	3 3/8	1 3/8	7/8	1	7 1/8	3 1/2	1 3/4	3/4	26.8	
2 7/8 2 15/16	SPD-46 SPD-47	2-214D 2-215D	3 3/4	13	9 1/4	10 3/4	3 3/8	1 1/2	7/8	1	7 3/16	3 1/2	1 3/4	3/4	26.8	
3 3 3/16	SPD-48 SPD-51	3-3D 2-33D	4	14 1/2	10 5/8	12 1/8	3 3/4	1 1/2	7/8	1 1/8	7 13/16	3 7/8	1 15/16	3/4	34.5	

For Load Ratings, see page 45. For Standard Duty Bearing Inserts-Double Lock, see page 44.  
See page 188 for custom seals.

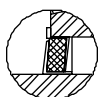

**Felt Seal Standard**  
Positive sealing for low, medium, and high speed operation.



**Single Lip Contact Seal**  
Available on all sizes. Recommended where moisture conditions prevail.  
To specify, add suffix "C" (NPD-16C).



**Hi-Temp Seal**  
Available as an option where operating temperatures are in 250-400° range.  
(See seal options on page 188).





MOUNTED BALL BEARINGS

**SEALMASTER®**

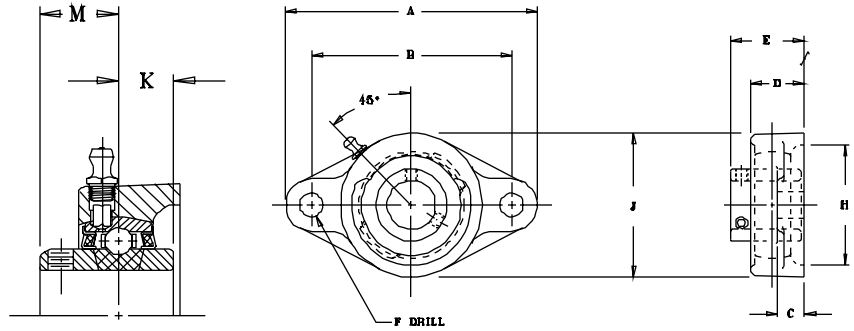

## SFT Series Standard Duty Two-Bolt Flange Units...Setscrew Locking

SHAFT DIAM.	PART NO.	BRG. NO.	Dimensions in Inches										UNIT WT.
			A	B	C	D	E	F	H CORED	J	K	M	
1/2 9/16 5/8 11/16	SFT-8 SFT-9 SFT-10 SFT-11	2-08 2-09 2-010 2-011	3 7/8	3	7/16	15/16	1 9/32	13/32	1 15/16	2 5/16	1/2	23/32	1.2
3/4 20	SFT-12 SFT-204	2-012 5204	4 13/32	3 17/32	7/16	15/16	1 9/32	13/32	2	2 3/8	1/2	23/32	1.2
13/16 7/8 15/16 1 25	SFT-13 SFT-14 SFT-15 SFT-16 SFT-205	2-013 2-014 2-015 2-1 5205	4 7/8	3 57/64	17/32	1 1/32	1 7/16	15/32	2 3/8	2 3/4	9/16	13/16	1.6
1 1/16 1 1/8 1 3/16 1 1/4 30	SFT-17 SFT-18 SFT-19 SFT-20R SFT-206	2-11 2-12 2-13 1-14 5206	5 9/16	4 19/32	17/32	1 11/64	1 9/16	15/32	2 7/8	3 1/4	5/8	7/8	2.2
1 1/4 1 5/16 1 3/8 1 7/16 35	SFT-20 SFT-21 SFT-22 SFT-23 SFT-207	2-14 2-15 2-16 2-17 5207	6 1/8	5 1/8	9/16	1 11/32	1 3/4	17/32	3 5/16	3 3/4	11/16	1	3.2
1 1/2 1 9/16 40	SFT-24 SFT-25 SFT-208	2-18 2-19 5208	6 3/4	5 21/32	9/16	1 1/2	2 1/64	17/32	3 1/2	4 1/8	3/4	1 3/16	4.5
1 5/8 1 11/16 1 3/4 45	SFT-26 SFT-27 SFT-28 SFT-209	2-110 2-111 2-112 5209	7 1/16	5 27/32	9/16	1 9/16	2 3/64	19/32	3 7/8	4 3/8	3/4	1 3/16	5.0
1 13/16 1 7/8 1 15/16 2 50	SFT-29 SFT-30 SFT-31 SFT-32R SFT-210	2-113 2-114 2-115 1-2 5210	7 7/16	6 3/16	9/16	1 9/16	2 5/32	19/32	4	4 9/16	3/4	1 9/32	5.4
2 2 1/8 2 3/16 55	SFT-32 SFT-34 SFT-35 SFT-211	2-2 2-22 2-23 5211	8 1/2	7 1/4	13/16	1 3/4	2 5/16	21/32	4 1/4	5 1/4	7/8	1-5/16	8.4

For Load Ratings, see page 45. For Standard Duty Bearing Inserts-Single Lock, see page 43.  
See page 27 for seal arrangements.

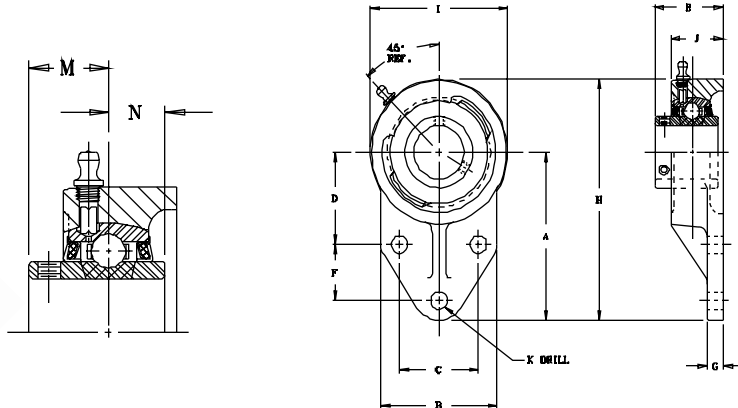

## FB Series Standard Duty Three Bolt Single Lock Flange Brackets...Setscrew Locking

SHAFT DIAM.	PART NO.	BRG. NO.	Dimensions in Inches													UNIT WT.
			A	B	C	D	E	F	G	H	I	J	K	M	N	
1/2 9/16 5/8 11/16 3/4 20	FB-8 FB-9 FB-10 FB-11 FB-12 FB-204	2-08 2-09 2-010 2-011 2-012 5204	3	2 3/8	1 1/2	1 11/16	1 11/32	7/8	5/16	4 1/4	2 1/2	1	25/64	23/32	1/2	1.3
13/16 7/8 15/16 1 25	FB-13 FB-14 FB-15 FB-16 FB-205	2-013 2-014 2-015 2-1 5205	3 3/8	2 1/2	1 5/8	1 13/16	1 1/2	1 1/8	3/8	4 3/4	2 3/4	1 1/8	25/64	13/16	9/16	2.1
1 1/16 1 1/8 1 3/16 1 1/4 30	FB-17 FB-18 FB-19 FB-20R FB-206	2-11 2-12 2-13 1-14 5206	3 3/4	2 3/4	1 7/8	2 1/16	1 5/8	1 1/4	3/8	5 3/8	3 1/4	1 1/4	25/64	7/8	5/8	3.0
1 1/4 1 5/16 1 3/8 1 7/16 35	FB-20 FB-21 FB-22 FB-23 FB-207	2-14 2-15 2-16 2-17 5207	4 1/4	3 1/4	2	2 3/8	1 7/8	1 1/4	1/2	6 1/8	3 3/4	1 7/16	33/64	1	11/16	3.1
1 13/16 1 7/8 1 15/16 2 50	FB-29 FB-30 FB-31 FB-32R FB-210	2-113 2-114 2-115 1-2 5210	5 3/16	4	2 3/4	2 15/16	2 5/32	1 5/8	1/2	7 1/2	4 5/8	1 1/2	33/64	1 9/32	3/4	5.1

For Load Ratings, see page 45. For Standard Duty Bearing Inserts-Single Lock, see page 43.

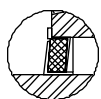

**Felt Seal Standard**  
Positive sealing for low, medium, and high speed operation.



**Single Lip Contact Seal**  
Available on all sizes. Recommended where moisture conditions prevail. To specify, add suffix "C" (FB-16C).

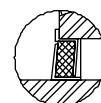

**Hi-Temp Seal**  
Available as an option where operating temperatures are in 250-400° range. (See seal options on page 188).



# MOUNTED BALL BEARINGS SEALMASTER®

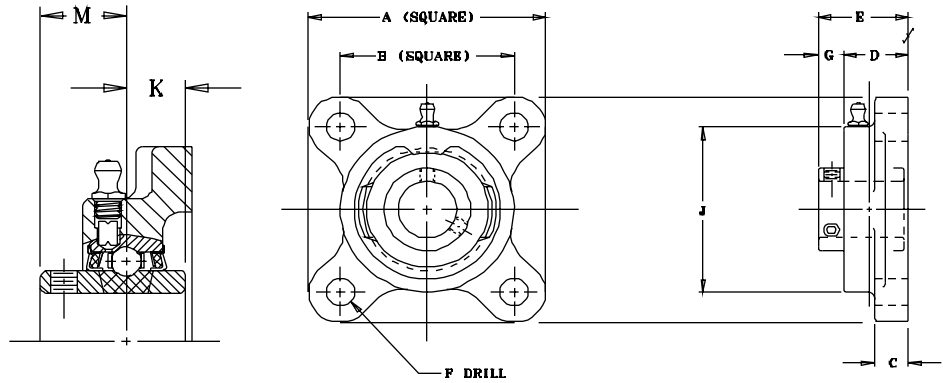

## SF Series Standard Duty Four-Bolt Flange Units...Setscrew Locking

SHAFT DIAM.		PART NO.	BRG. NO.	Dimensions in Inches									UNIT WT.
				A	B	C	D	E	F	G	J	K	
IN	MM												
1/2		SF-8	2-08										
9/16		SF-9	2-09										
5/8		SF-10	2-010	3	2 1/8	7/16	15/16	1 9/32	13/32	11/32	2 5/16	1/2	23/32
11/16		SF-11	2-011										
3/4	20	SF-12	2-012	3 3/8	2 1/2	7/16	15/16	1 9/32	13/32	11/32	2 3/8	1/2	23/32
		SF-204	5204										
13/16		SF-13	2-013										
7/8		SF-14	2-014										
15/16		SF-15	2-015	3 3/4	2 3/4	17/32	1 1/32	1 7/16	15/32	13/32	2 23/32	9/16	13/16
1	25	SF-16	2-1										
		SF-205	5205										
1 1/16		SF-17	2-11										
1 1/8		SF-18	2-12										
1 3/16		SF-19	2-13	4 1/4	3 1/4	17/32	1 11/64	1 9/16	15/32	25/64	3 7/32	5/8	7/8
1 1/4	30	SF-20R	1-14										
		SF-206	5206										
1 1/4		SF-20	2-14										
1 5/16		SF-21	2-15										
1 3/8		SF-22	2-16	4 5/8	3 5/8	9/16	1 11/32	1 3/4	17/32	13/32	3 23/32	11/16	1
1 7/16	35	SF-23	2-17										
		SF-207	5207										
1 1/2		SF-24	2-18										
1 9/16	40	SF-25	2-19	5 1/8	4	9/16	1 1/2	2 1/64	17/32	33/64	4 5/64	3/4	1 3/16
		SF-208	5208										
1 5/8		SF-26	2-110										
1 11/16		SF-27	2-111										
1 3/4	45	SF-28	2-112	5 3/8	4 1/8	9/16	1 9/16	2 3/64	19/32	31/64	4 21/64	3/4	1 3/16
		SF-209	5209										
1 13/16		SF-29	2-113										
1 7/8		SF-30	2-114										
1 15/16		SF-31	2-115	5 5/8	4 3/8	9/16	1 9/16	2 5/32	19/32	19/32	4 9/16	3/4	1 9/32
2	50	SF-32R	1-2										
		SF-210	5210										
2		SF-32	2-2										
2 1/8		SF-34	2-22										
2 3/16	55	SF-35	2-23	6 3/8	5 1/8	13/16	1 3/4	2 5/16	21/32	9/16	5 1/4	7/8	1 5/16
		SF-211	5211										
2 1/4		SF-36	2-24										
2 3/8		SF-38	2-26										
2 7/16	60	SF-39	2-27	6 7/8	5 5/8	13/16	1 15/16	2 11/16	21/32	3/4	5 7/16	1	1 9/16
		SF-212	5212										
2 1/2		SF-40	3-28										
2 11/16	70	SF-43	2-211	7 3/8	5 7/8	11/16	2 5/16	3	21/32	11/16	6 1/8	1 1/16	1 11/16
		SF-214	5214										
2 7/8		SF-46	2-214										
2 15/16	75	SF-47	2-215	7 3/4	6	1	2 3/8	3 3/16	25/32	13/16	6 1/2	1 5/16	1 3/4
		SF-215	5215										

# SEALMASTER<sup>®</sup> MOUNTED BALL BEARINGS

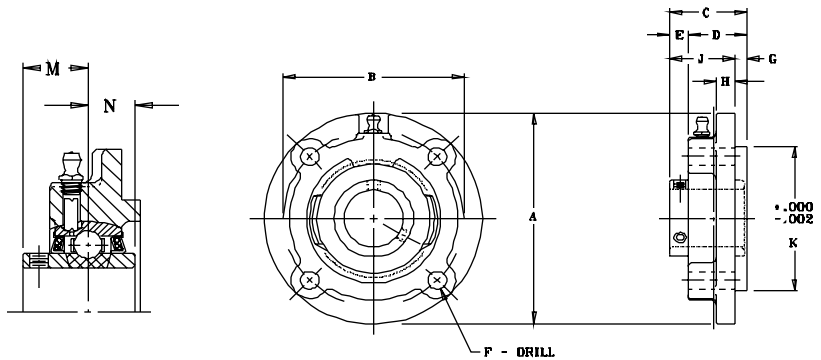

## SFC Series Standard Duty Flange Cartridge Units... Setscrew Locking

SHAFT DIAM.		PART NO.	BRG. NO.	Dimensions In Inches											UNIT WT.		
				A	B	C	D	E	F	G	H	J	K	M		N	
1 1/8		SFC-18	2-12														
1 3/16		SFC-19	2-13														
1 1/4		SFC-20R	1-14	4 3/8	3 5/8	1 9/16	1 3/16	3/8	3/8	1/4	3/8	1 5/16	3.000	7/8	5/8	3.0	
	30	SFC-206	5206														
1 1/4		SFC-20	2-14														
1 5/16		SFC-21	2-15														
1 3/8		SFC-22	2-16	5	4 1/8	1 11/16	1 1/4	7/16	7/16	3/8	3/8	1 5/16	3.375	1	11/16	3.9	
1 7/16		SFC-23	2-17														
	35	SFC-207	5207														
1 1/2		SFC-24	2-18														
1 9/16		SFC-25	2-19	5 1/4	4 3/8	1 15/16	1 15/32	15/32	7/16	7/16	7/16	1 1/2	3.625	1 3/16	3/4	4.7	
	40	SFC-208	5208														
1 5/8		SFC-26	2-110														
1 11/16		SFC-27	2-111														
1 3/4		SFC-28	2-112	6 1/8	5 1/8	1 15/16	1 7/16	1/2	1/2	7/16	7/16	1 1/2	4.250	1 3/16	3/4	6.0	
	45	SFC-209	5209														
1 7/8		SFC-30	2-114														
1 15/16		SFC-31	2-115														
2		SFC-32R	1-2	6 1/8	5 1/8	2 1/32	1 15/32	9/16	1/2	15/32	7/16	1 9/16	4.250	1 9/32	3/4	6.5	
	50	SFC-210	5210														
2		SFC-32	2-2														
2 1/8		SFC-34	2-22														
2 3/16		SFC-35	2-23	6 3/8	5 3/8	2 3/16	1 5/8	9/16	1/2	5/8	7/16	1 9/16	4.500	1 5/16	7/8	7.5	
	55	SFC-211	5211														
2 1/4		SFC-36	2-24														
2 3/8		SFC-38	2-26														
2 7/16		SFC-39	2-27	7 1/8	6	2 9/16	1 7/8	11/16	9/16	7/8	1/2	1 11/16	5.000	1 9/16	1	10.5	
	60	SFC-212	5212														
2 11/16		SFC-43	2-211														
70		SFC-214	5214	7 5/8	6 1/2	2 7/8	2 3/16	11/16	9/16	1 1/8	9/16	1 3/4	5.500	1 11/16	1 1/16	14.0	
2 7/8		SFC-46	2-214														
2 15/16		SFC-47	2-215	8 3/4	7 1/2	3 1/16	2 5/16	3/4	11/16	1 1/16	9/16	2	6.375	1 3/4	1 5/16	18.7	
	75	SFC-215	5215														
3 3/16		SFC-51	2-33														
80		SFC-216	5216	8 3/4	7 1/2	3 1/4	2 7/16	13/16	11/16	1 1/4	5/8	2	6.375	1 15/16	1 5/16	20.0	

For Load Ratings, see page 45. For Standard Duty Bearing Inserts-Single Lock, see page 43.

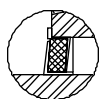

**Felt Seal Standard**  
Positive sealing for low, medium, and high speed operation.



**Single Lip Contact Seal**  
Available on all sizes. Recommended where moisture conditions prevail. To specify, add suffix "C" (SFC-16C).

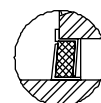

**Hi-Temp Seal**  
Available as an option where operating temperatures are in 250-400° range. (See seal options on page 188).



# MOUNTED BALL BEARINGS SEALMASTER®

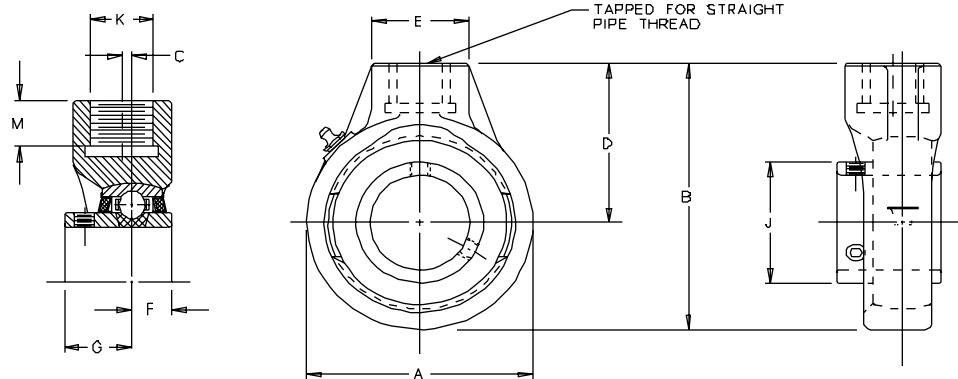

## SEHB Series Hanger Bearing For Eccentric Drives...Setscrew Locking

SHAFT DIAM. IN MM	SERIES	PART NO.	BRG. NO.	Dimensions In Inches								*K Pipe Tap N.P.S.M.	M Thread Length	Unit Wt.
				A	B	C	D	E	F	G	J Approx			
15/16 1 1/4 1 1/16 1 3/8 30	2-13	SEHB-15 SEHB-305 SEHB-16 SEHB-18 SEHB-206	3-015 5305 3-1 2-12 5206	3 1/8	4 1/16	—	2 1/2	1 9/16	5/8	7/8	1 19/32	3/4 - 14	13/16	2.2
1 3/16 1 1/4 1 5/16 1 3/8 35	2-17	SEHB-19 SEHB-20 SEHB-21 SEHB-22 SEHB-207	3-13 2-14 2-15 2-16 5207	3 5/8	4 9/16	—	2 3/4	1 9/16	11/16	1	1 55/64	3/4 - 14	3/4	3.1
1 7/16 1 1/2 1 9/16 40	2-19	SEHB-23 SEHB-24 SEHB-25 SEHB-208	3-17 2-18 2-19 5208	3 3/4	4 3/4	3/32	2 7/8	1 9/16	3/4	1 3/16	2 1/16	3/4 - 14	3/4	3.4
1 11/16 1 3/4 1 7/8 1 15/16 2 50	2-115	SEHB-27 SEHB-28 SEHB-30 SEHB-31 SEHB-32 SEHB-210	3-111 3-112 2-114 2-115 1-2 5210	4 3/8	5 7/16	3/16	3 1/4	1 7/8	3/4	1 9/32	2 15/32	1 - 11 1/2	13/16	4.5
2 3/16 2 1/4 2 3/8 2 7/16 60	2-27	SEHB-35 SEHB-36 SEHB-38 SEHB-39 SEHB-212	3-23 2-24 2-26 2-27 5212	5 5/8	6 13/16	11/32	4	2 5/16	1	1 9/16	2 63/64	1 1/4 - 11 1/2	1 1/8	9.0
2 11/16 2 7/8 2 15/16 75	2-215	SEHB-43 SEHB-46 SEHB-47 SEHB-215	3-211 2-214 2-215 5215	6 1/2	7 7/8	3/8	4 5/8	2 3/4	1 5/16	1 3/4	3 41/64	1 1/2 - 11 1/2	1 1/4	14.6
3 3 3/16 80	2-33	SEHB-48 SEHB-51 SEHB-216	3-3 2-33 5216	6 7/8	8 5/16	5/16	4 7/8	2 13/16	1 5/16	1 15/16	3 59/64	1 1/2 - 11 1/2	1 1/4	16.8
3 15/16 4 100	2-43	SEHB-63 SEHB-64 SEHB-320	3-315 3-4 5320	10 1/4	13 1/4	—	8 1/8	4 3/8	1 15/16	2 11/16	5 11/64	2 1/2-8 1/2	2 5/8	62.0

For Load Ratings, see page 45.

For Standard Duty Bearing Inserts-Single Lock, see page 43.

\* Use Straight Pipe Thread.

Note: Units may be provided with tight internal and housing fits by adding suffix **BDZ** to Part No., as **SEHB-19 BDZ**



**Single Lip Contact Seal**  
Available on all sizes. Recommended where moisture conditions prevail. To specify, add suffix "C" (SEHB-16C).

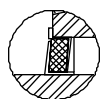

**Felt Seal Standard**  
Positive sealing for low, medium, and high speed operation.

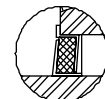

**Hi-Temp Seal**  
Available as an option where operating temperatures are in 250-400° range. (See seal options on page 188).

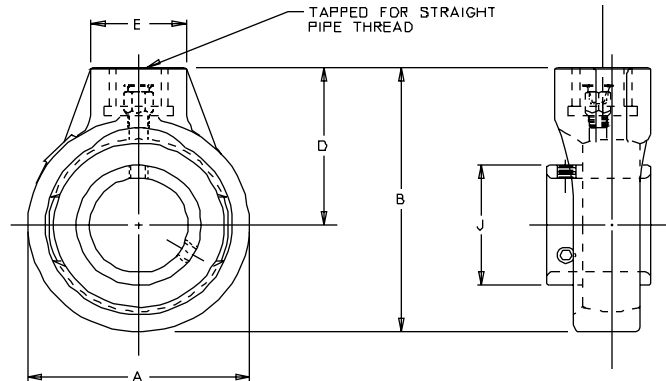
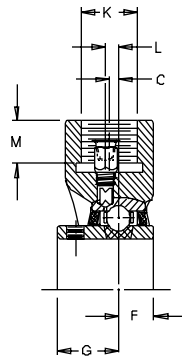

## SCHB Series Hanger Bearing For Screw Conveyors...Setscrew Locking

SHAFT DIAM. IN MM	SERIES	PART NO.	BRG. NO.	Dimensions In Inches								*K Pipe Tap N.P.S.M.	M Thread Length	L Brg. to Lub.Ftg. Centers	Unit Wt.
				A	B	C	D	E	F	G	J Approx				
15/16 1 1 1/16 30	2-13	SCHB-15 SCHB-305 SCHB-16 SCHB-18 SCHB-206	3-015 5305 3-1 2-12 5206	3 1/8	4 1/16	—	2 1/2	1 9/16	5/8	7/8	1 19/32	3/4" - 14	3/4	◆7/32	2.2
1 3/16 1 1/4 1 5/16 1 3/8 35	2-17	SCHB-19 SCHB-20 SCHB-21 SCHB-22 SCHB-207	3-13 2-14 2-15 2-16 5207	3 5/8	4 9/16	—	2 3/4	1 9/16	11/16	1	1 55/64	3/4" - 14	3/4	◆1/4	3.1
1 7/16 1 1/2 1 9/16 40	2-19	SCHB-23 SCHB-24 SCHB-25 SCHB-208	3-17 2-18 2-19 5208	3 3/4	4 3/4	3/32	2 7/8	1 9/16	3/4	1 3/16	2 1/16	3/4"-14	3/4	◆19/64	3.4
1 11/16 1 3/4 1 7/8 1 15/16 2 50	2-115	SCHB-27 SCHB-28 SCHB-30 SCHB-31 SCHB-32 SCHB-210	3-111 3-112 2-114 2-115 1-2 5210	4 3/8	5 7/16	3/16	3 1/4	1 7/8	3/4	1 9/32	2 15/32	1" - 11 1/2	13/16	17/64	4.5
2 3/16 2 1/4 2 3/8 2 7/16 60	2-27	SCHB-35 SCHB-36 SCHB-38 SCHB-39 SCHB-212	3-23 2-24 2-26 2-27 5212	5 5/8	6 13/16	11/32	4	2 5/16	1	1 9/16	2 63/64	1 1/4" - 11 1/2	1 1/8	21/64	9.0
2 11/16 2 7/8 2 15/16 75	2-215	SCHB-43 SCHB-46 SCHB-47 SCHB-215	3-211 2-214 2-215 5215	6 1/2	7 7/8	3/8	4 5/8	2 3/4	1 5/16	1 3/4	3 41/64	1 1/2" - 11 1/2	1 1/4	3/8	14.6
3 3 3/16 80	2-33	SCHB-48 SCHB-51 SCHB-216	SK-110 2-33 5216	6 7/8	8 5/16	5/16	4 7/8	2 13/16	1 5/16	1 15/16	3 59/64	1 1/2" - 11 1/2	1 1/4	13/32	16.8
3 15/16 4 100	2-43	SCHB-63 SCHB-64 SCHB-320	3-315 3-4 5320	10 1/4	13 1/4	—	8 1/8	4 3/8	1 15/16	2 11/16	5 11/64	2 1/2" - 8 1/2	2 5/8	15/32	62.0

For Load Ratings, see page 45. For Standard Duty Bearing Inserts-Single Lock, see page 43.

◆ No Adaptor or Fitting

\* Use Straight Pipe Thread

See page 30 for seal arrangements.

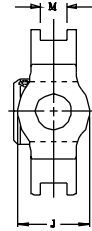
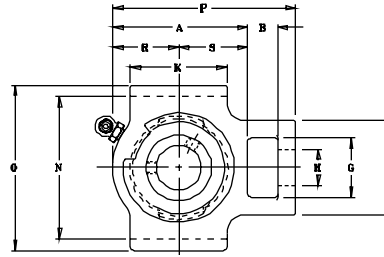
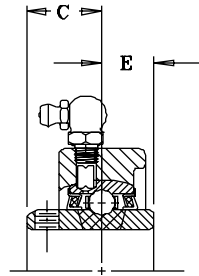

**ST Series Standard Duty Take-Up Units...Setscrew Locking**

SHAFT DIAM.	PART NO.	BRG. NO.	Dimensions In Inches														UNIT WT.	
			A	B	C	E	F	G	H Core	J Hub	K	M	N	O	P	R		S
1/2 9/16 5/8 11/16 3/4 20	ST-8 ST-9 ST-10 ST-11 ST-12 ST-204	2-08 2-09 2-010 2-011 2-012 5204	2 11/16	5/8	23/32	1/2	2	1 1/4	3/4	1 3/8	2	17/32	3	3 1/2	3 11/16	1 5/16	1 3/8	2.1
13/16 7/8 15/16 1 25	ST-13 ST-14 ST-15 ST-16 ST-205	2-013 2-014 2-015 2-1 5205	2 13/16	5/8	13/16	9/16	2	1 1/4	3/4	1 1/2	2	17/32	3	3 1/2	3 13/16	1 3/8	1 7/16	2.6
1 1/16 1 1/8 1 3/16 1 1/4 30	ST-17 ST-18 ST-19 ST-20R ST-206	2-11 2-12 2-13 1-14 5206	3 7/16	5/8	7/8	5/8	2 3/16	1 7/16	7/8	1 3/4	2 1/4	17/32	3 1/2	4	4 7/16	1 11/16	1 3/4	3.4
1 1/4 1 5/16 1 3/8 1 7/16 35	ST-20 ST-21 ST-22 ST-23 ST-207	2-14 2-15 2-16 2-17 5207	3 15/16	5/8	1	11/16	2 1/2	1 7/16	7/8	1 3/4	2 1/2	17/32	3 1/2	4	5 1/16	2	1 15/16	4.0
1 1/2 1 9/16 40	ST-24 ST-25 ST-208	2-18 2-19 5208	4 5/16	3/4	1 3/16	3/4	3 1/4	1 15/16	1 1/8	2 1/8	3 1/4	11/16	4	4 1/2	5 11/16	2 3/16	2 1/8	6.0
1 5/8 1 11/16 1 3/4 45	ST-26 ST-27 ST-28 ST-209	2-110 2-111 2-112 5209	4 5/16	3/4	1 3/16	3/4	3 1/4	1 15/16	1 1/8	2 3/16	3 1/4	11/16	4	4 5/8	5 11/16	2 1/4	2 1/16	6.0
1 13/16 1 7/8 1 15/16 2 50	ST-29 ST-30 ST-31 ST-32R ST-210	2-113 2-114 2-115 1-2 5210	4 1/2	3/4	1 9/32	3/4	3 1/4	1 15/16	1 1/8	2 3/16	3 3/8	11/16	4	4 5/8	5 7/8	2 5/16	2 3/16	6.0
2 2 1/8 2 3/16 55	ST-32 ST-34 ST-35 ST-211	2-2 2-22 2-23 5211	5	1	1 5/16	7/8	4	2 1/2	1 3/8	2 1/4	3 3/4	1 1/16	5 1/8	5 3/4	6 3/4	2 9/16	2 7/16	9.8
2 1/4 2 3/8 2 7/16 60	ST-36 ST-38 ST-39 ST-212	2-24 2-26 2-27 5212	5 5/8	1 1/4	1 9/16	1	4	2 1/2	1 3/8	2 3/8	4	1 1/16	5 1/8	5 3/4	7 5/8	2 15/16	2 11/16	12.3
2 1/2 2 11/16 70	ST-40 ST-43 ST-214	3-28 2-211 5214	6 3/4	1 1/4	1 11/16	1 1/16	4 3/8	2 3/4	1 5/8	3 3/8	4 3/4	1 1/16	5 15/16	6 9/16	8 13/16	3 7/16	3 5/16	19.0
2 7/8 2 15/16 75	ST-46 ST-47 ST-215	2-214 2-215 5215	7 1/16	1 1/4	1 3/4	1 5/16	4 3/8	2 3/4	1 5/8	3 3/8	4 3/4	1 1/16	5 15/16	6 9/16	9 1/8	3 5/8	3 7/16	19.0
3 3/16 80	ST-51 ST-216	2-33 5216	7 3/16	1 1/4	1 15/16	1 5/16	4 3/8	2 3/4	1 5/8	3 3/8	4 3/4	1 1/16	6 1/2	7 1/4	9 1/4	3 3/4	3 7/16	22.1
3 1/4 3 3/8 3 7/16	ST-52 ST-54 ST-55	2-34 2-36 2-37	7 5/8	1 1/2	2 1/32	1 11/32	4 7/8	2 7/8	1 7/8	3 1/2	6 3/16	1 13/16	6 13/16	7 13/16	10 1/4	3 7/8	3 3/4	31.4

For Load Ratings, see page 45. For Standard Duty Bearing Inserts-Single Lock, see page 43. For Take-Up Frames, see pages 36 & 37. See page 30 for seal arrangements. For custom seals see page 188.

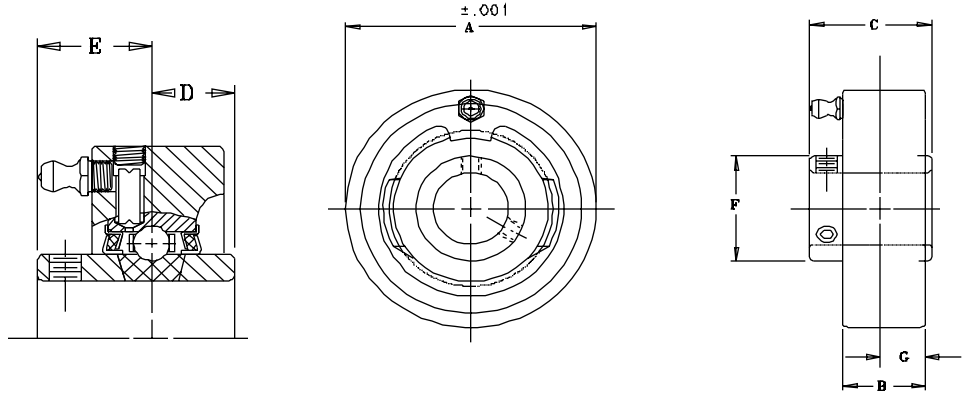

## SC Series Standard Duty Cartridge Units...Setscrew Locking

SHAFT DIAM.	PART NO.	BRG. NO.	Dimensions In Inches							UNIT WT.
			A	B	C	D	E	F	G	
1/2 9/16 5/8 11/16	SC-8 SC-9 SC-10 SC-11	2-08 2-09 2-010 2-011	2 11/16	7/8	1 7/32	1/2	23/32	1 3/16	15/32	1.1
3/4 20	SC-12 SC-204	2-012 5204	2 15/16	7/8	1 7/32	1/2	23/32	1 3/16	15/32	1.4
13/16 7/8 15/16 1	SC-13 SC-14 SC-15 SC-16 SC-205	2-013 2-014 2-015 2-1 5205	3 1/8	1 1/32	1 3/8	9/16	13/16	1 3/8	9/16	1.9
1 1/16 1 1/8 1 3/16 1 1/4	SC-17 SC-18 SC-19 SC-20R SC-206	2-11 2-12 2-13 1-14 5206	3 1/2	1 3/32	1 1/2	5/8	7/8	1 19/32	9/16	2.5
1 1/4 1 5/16 1 3/8 1 7/16	SC-20 SC-21 SC-22 SC-23 SC-207	2-14 2-15 2-16 2-17 5207	3 7/8	1 7/32	1 11/16	11/16	1	1 55/64	5/8	3.2
1 1/2 1 9/16 40	SC-24 SC-25 SC-208	2-18 2-19 5208	4 3/16	1 15/32	1 15/16	3/4	1 3/16	2 1/16	3/4	4.1
1 5/8 1 11/16 1 3/4 45	SC-26 SC-27 SC-28 SC-209	2-110 2-111 2-112 5209	4 3/8	1 7/16	1 15/16	3/4	1 3/16	2 19/64	23/32	4.5
1 13/16 1 7/8 1 15/16 2	SC-29 SC-30 SC-31 SC-32R SC-210	2-113 2-114 2-115 1-2 5210	4 9/16	1 15/32	2 1/32	3/4	1 9/32	2 15/32	3/4	4.9
2 2 1/8 2 3/16 55	SC-32 SC-34 SC-35 SC-211	2-2 2-22 2-23 5211	4 15/16	1 19/32	2 3/16	7/8	1 5/16	2 23/32	27/32	5.8
2 1/4 2 3/8 2 7/16 60	SC-36 SC-38 SC-39 SC-212	2-24 2-26 2-27 5212	5 7/8	1 5/8	2 9/16	1	1 9/16	2 63/64	13/16	9.0
2 1/2 2 11/16 70	SC-40 SC-43 SC-214	3-28 2-211 5214	6 1/4	2	2 3/4	1 1/16	1 11/16	3 7/16	1	12.6
2 7/8 2 15/16 75	SC-46 SC-47 SC-215	2-214 2-215 5215	6 5/8	2	3 1/16	1 5/16	1 3/4	3 41/64	1	13.5

For Load Ratings, see page 45. For Standard Duty Bearing Inserts-Single Lock, see page 43. See page 30 for seal arrangements. For custom seals see page 188.



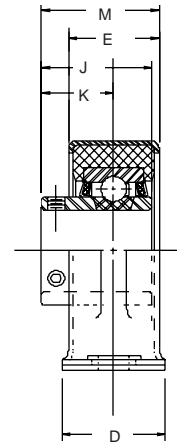
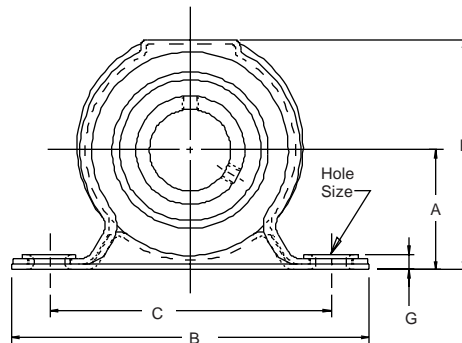

**SRP Series Standard Duty Rubber Mounted Pillow Blocks...Setscrew Locking**

SHAFT DIA.		MAX. STEADY RADIAL LOADS LBS.	PART NUMBER	INSERT NUMBER	Dimensions In Inches											BOLT SIZE	UNIT WT.
IN	MM				A	B	C	D	E	HOLE SIZE	G	H	J	K	M		
1/2 5/8 3/4	20	200	SRP-8 SRP-10 SRP-12 SRP-20-4	SRC-8 SRC-10 SRC-12 RB-204	1 1/2	4 3/4	3 5/8	1 5/16	1 1/8	7/16	11/64	2 13/16	1 9/32	7/8	1 7/16	3/8	.85
7/8 15/16 1 1	25	200	SRP-14 SRP-15 SRP-16 SRP-20-6 SRP-17	SRC-14 SRC-15 SRC-16 RB-205	1 1/2	4 3/4	3 5/8	1 5/16	1 1/8	7/16	11/64	2 13/16	1 3/8	7/8	1 7/16	3/8	1.00
1/16 1 1/8 1 3/16 1 1/4	30	300	SRP-18 SRP-19 SRP-20-R SRP-20-	SRC-17 SRC-18 SRC-19 SRC-20R RB-206	1 3/4	5 1/4	4 1/8	1 1/2	1 11/32	7/16	1/4	3 3/8	1 5/8	1 1/16	1 47/64	3/8	1.60

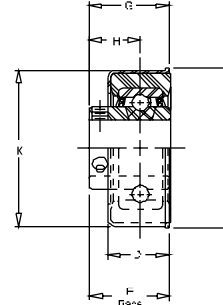
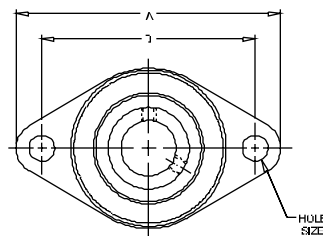

**SRF Series Standard Duty Rubber Mounted Flange Blocks...Setscrew Locking**

SHAFT DIA.		MAX. STEADY RADIAL LOADS LBS.	PART NUMBER	INSERT NUMBER	Dimensions In Inches											BOLT SIZE	UNIT WT.
IN	MM				A	B	D	E	HOLE SIZE	G	H	J	K				
1/2 5/8 3/4	20	400	SRF-8 SRF-10 SRF-12 SRF-20-4	SRC-8 SRC-10 SRC-12 SRC-204	4 1/2	3 5/8	1 1/16	1 9/32	7/16	1 13/32	7/8	2 45/64	2 41/64	3/8	.75		
7/8 15/16 1 1	25	400	SRF-14 SRF-15 SRF-16 SRF-20-6 SRF-17	SRC-14 SRC-15 SRC-16 SRC-205	4 1/2	3 5/8	1 1/16	1 3/8	7/16	1 13/32	7/8	2 45/64	2 41/64	3/8	.85		
1/16 1 1/8 1 3/16 1 1/4	30	600	SRF-18 SRF-19 SRF-20-R SRF-20-	SRC-17 SRC-18 SRC-19 SRC-20R SRC-206	5 3/8	4 3/8	1 1/4	1 5/8	1/2	1 21/32	1 1/16	3 1/2	3 1/4	7/16	1.50		

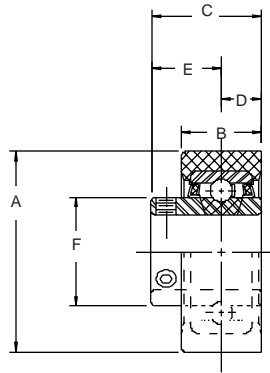

## SRC Series Standard Duty Rubber Mounted Cartridge Units...Setscrew Locking

SHAFT DIA.		MAX. STEADY RADIAL LOADS LBS.	PART NUMBER	INSERT NUMBER	Dimensions In Inches						UNIT WT.
IN	MM				A	B	C	D	E	F	
1/2 5/8 3/4	20	200	SRC-8	RB-8	2 17/32	1	1 9/32	13/32	7/8	1 3/16	.60
			SRC-10	RB-10							
			SRC-12 SRC-204	RB-12 RB-204							
7/8 15/16 1	25	200	SRC-14	RB-14	2 17/32	1	1 3/8	1/2	7/8	1 3/8	.65
			SRC-15	RB-15							
			SRC-16 SRC-205	RB-16 RB-205							
1 1/16 1 1/8 1 3/16 1 1/4	30	300	SRC-17	RB-17	3 3/32	1 3/16	1 5/8	9/16	1 1/16	1 19/32	1.00
			SRC-18	RB-18							
			SRC-19 SRC-20R SRC-206	RB-19 RB-20R RB-206							

Maximum steady radial load is based upon the housing strength and materials composition. Thrust load ratings 40% of radial loads.

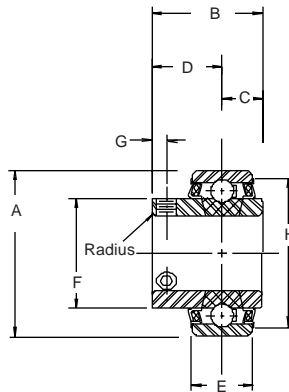

The "RB" Bearing assembly is used as a bearing insert in the "SRP" Rubber mounted Pillow Blocks and the "SRF" Rubber mounted two-bolt flange units. The bearing assembly is permanently sealed and lubricated for life.



Felt Seal Standard  
Positive sealing for low, medium, and high speed operation.

## RB Series Bearing Assemblies

SHAFT DIA.		PART NUMBER	Dimensions In Inches									Set Screw Tap	UNIT WT.
IN	MM		A	B	C	D	E	F	G	Radius	H		
1/2 5/8 3/4	20	RB-8	47mm 1.850	1 9/32	13/32	7/8	5/8	1 3/16	3/16	.040	1 5/8	1/4-28	.50
		RB-10											
		RB-12 RB-204											
7/8 15/16 1	25	RB-14	52mm 2.047	1 3/8	1/2	7/8	3/4	1 3/8	3/16	.040	1 55/64	1/4-28	.60
		RB-15											
		RB-16 RB-205											
1 1/16 1 1/8 1 3/16 1 1/4	30	RB-17	62mm 2.441	1 5/8	9/16	1 1/16	7/8	1 19/32	7/32	.040	2 5/32	1/4-28	.90
		RB-18											
		RB-19 RB-20R RB-206											



MOUNTED BALL BEARINGS

**SEALMASTER®**

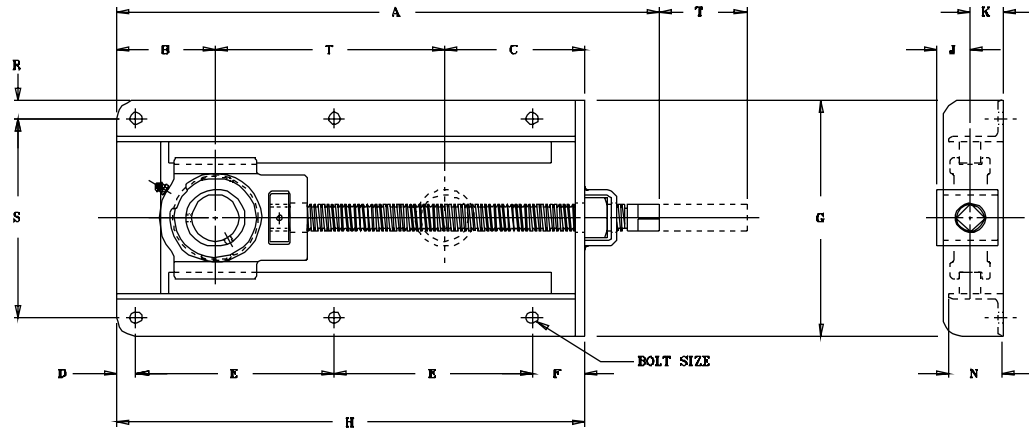
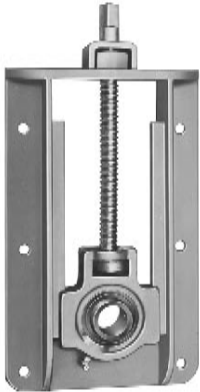

## STH Series Style "H" Steel Frame Take-Ups...Setscrew Locking

SHAFT DIAM. IN MM	PART NO.	BRG. NO.	Dimensions in Inches														BOLT SIZE	UNIT WT.
			T	A	B	C	D	E	F	G	H	J	K	N	R	S		
7/8 15/16 1 25	STH-14-6 STH-15-6 STH-16-6 STH-205-6	2-014 2-015 2-1 5205	6	15	3 1/4	3 1/4	3/4	4 5/8	2 1/2	7 9/16	12 1/2	13/16	1 1/8	1 3/4	3/4	6 1/16	3/8	11.6
7/8 15/16 1 25	STH-14-9 STH-15-9 STH-16-9 STH-205-9	2-014 2-015 2-1 5205	9	18	3 1/4	3 1/4	3/4	6 1/8	2 1/2	7 9/16	15 1/2	13/16	1 1/8	1-3/4	3/4	6 1/16	3/8	13.6
1 1/8 1 3/16 30	STH-18-6 STH-19-6 STH-206-6	2-12 2-13 5206	6	16 1/8	3 3/4	3 1/2	3/4	5	2 1/2	8 1/16	13 1/4	7/8	1 1/4	1-3/4	3/4	6 9/16	3/8	14.1
1 1/8 1 3/16 30	STH-18-9 STH-19-9 STH-206-9	2-12 2-13 5206	9	19 1/8	3 3/4	3 1/2	3/4	6 1/2	2 1/2	8 1/16	16 1/4	7/8	1 1/4	1-3/4	3/4	6 9/16	3/8	16.0
1 1/4 1 3/8 1 7/16 35	STH-20-9 STH-22-9 STH-23-9 STH-207-9	2-14 2-16 2-17 5207	9	19 11/16	4	3 7/8	3/4	6 13/16	2 1/2	8 1/16	16 7/8	1	1 1/4	1-3/4	3/4	6 9/16	3/8	17.4
1 1/4 1 3/8 1 7/16 35	STH-20-12 STH-22-12 STH-23-12 STH-207-12	2-14 2-16 2-17 5207	12	22 11/16	4	3 7/8	3/4	8 5/16	2 1/2	8 1/16	19 7/8	1	1 1/4	1-3/4	3/4	6 9/16	3/8	19.5
1 1/2 1 9/16 40 1 5/8 1 11/16 1 3/4 45	STH-24-12 STH-25-12 STH-208-12 STH-26-12 STH-27-12 STH-28-12 STH-209-12	2-18 2-19 5208 2-110 2-111 2-112 5209	12	23 9/16	4 1/4	4 1/4	7/8	8 9/16	2 1/2	9 5/16	20 1/2	1 3/16	1 3/8	2	7/8	7 9/16	3/8	27.2
1 1/2 1 9/16 40 1 5/8 1 11/16 1 3/4 45	STH-24-18 STH-25-18 STH-208-18 STH-26-18 STH-27-18 STH-28-18 STH-209-18	2-18 2-19 5208 2-110 2-111 2-112 5209	18	29 9/16	4 1/4	4 1/4	7/8	11 9/16	2 1/2	9 5/16	26 1/2	1 3/16	1 3/8	2	7/8	7 9/16	3/8	32.0

The STH series style H, are side mounting frame take-up units designed to incorporate either the ST or MST series take-up units (see pages 32 & 58), as indicated in the accompanying charts. They are used where shaft adjustment and/or belt tightening is required in conveyor applications. They are manufactured from heavy gauge structural steel members and equipped with heavy duty Acme (square) threads for positive action. Adjustment is made by turning the square head with an open end wrench.

Part numbers shown include standard duty take-up bearing (see page 32).

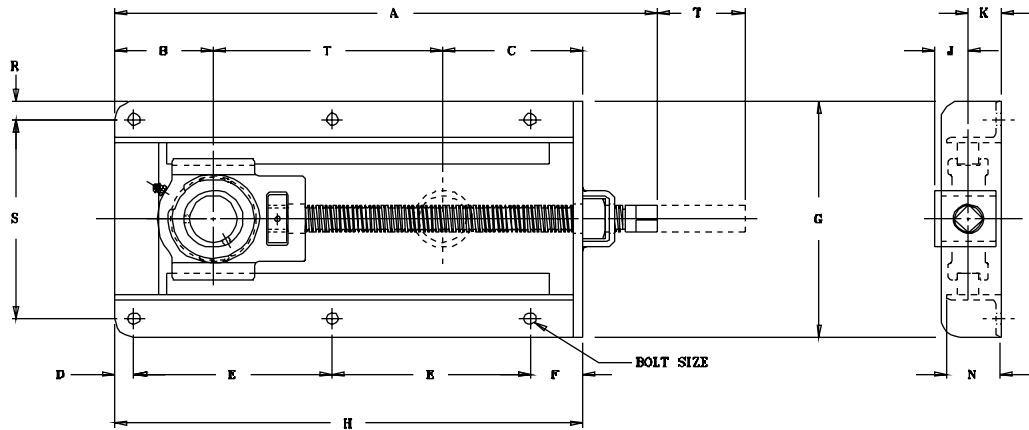

## STH Series Style "H" Steel Frame Take-Ups...Setscrew Locking

SHAFT DIAM. IN MM	PART NO.	BRG. NO.	Dimensions in Inches														BOLT SIZE	UNIT WT.
			T	A	B	C	D	E	F	G	H	J	K	N	R	S		
1 7/8 1 15/16 50	STH-30-12 STH-31-12 STH-210-12	2-114 2-115 5210	12	23 11/16	4 1/4	4 3/8	7/8	8 5/8	2 1/2	9 5/16	20 5/8	1 9/32	1 3/8	2	7/8	7 9/16	1/2	27.2
1 7/8 1 15/16 50	STH-30-18 STH-31-18 STH-210-18	2-114 2-115 5210	18	29 11/16	4 1/4	4 3/8	7/8	11 5/8	2 1/2	9 5/16	26 5/8	1 9/32	1 3/8	2	7/8	7 9/16	1/2	33.0
2 2 1/8 2 3/16 55	STH-32-12 STH-34-12 STH-35-12 STH-211-12	2-2 2-22 2-23 5211	12	24 13/16	4 1/2	4 7/8	7/8	9 1/16	2 3/8	11 3/16	21 3/8	1 5/16	1 1/2	2 1/2	7/8	9 7/16	1/2	41.6
2 2 1/8 2 3/16 55	STH-32-18 STH-34-18 STH-35-18 STH-211-18	2-2 2-22 2-23 5211	18	30 13/16	4 1/2	4 7/8	7/8	12 1/16	2 3/8	11 3/16	27 3/8	1 5/16	1 1/2	2 1/2	7/8	9 7/16	1/2	50.6
2 1/4 2 3/8 2 7/16 60	STH-36-12 STH-38-12 STH-39-12 STH-212-12	2-24 2-26 2-27 5212	12	25 9/16	5	5 3/8	7/8	9 9/16	2 3/8	11 3/16	22 3/8	1 9/16	1 1/2	2 1/2	7/8	9 7/16	1/2	45.0
2 1/4 2 3/8 2 7/16 60	STH-36-18 STH-38-18 STH-39-18 STH-212-18	2-24 2-26 2-27 5212	18	31 9/16	5	5 3/8	7/8	12 9/16	2 3/8	11 3/16	28 3/8	1 9/16	1 1/2	2 1/2	7/8	9 7/16	1/2	53.0
2 1/2 2 11/16 70 2 7/8 2 15/16 75	STH-40-12 STH-43-12 STH-214-12 STH-46-12 STH-47-12 STH-215-12	3-28 2-211 5214 2-214 2-215 5215	12	27 1/2	5 11/16	6 3/16	7/8	10 1/4	2 1/2	12	23 7/8	1 11/16 1 3/4	2	3	7/8	10 1/4	5/8	62.5
2 1/2 2 11/16 70 2 7/8 2 15/16 75	STH-40-18 STH-43-18 STH-214-18 STH-46-18 STH-47-18 STH-215-18	3-28 2-211 5214 2-214 2-215 5215	18	33 1/2	5 11/16	6 3/16	7/8	13 1/4	2 1/2	12	29 7/8	1 11/16 1 3/4	2	3	7/8	10 1/4	5/8	73.7

The STH series style H, are side mounting frame take-up units designed to incorporate either the ST or MST series take-up units (see pages 32 & 58), as indicated in the accompanying charts. They are used where shaft adjustment and/or belt tightening is required in conveyor applications. They are manufactured from heavy gauge structural steel members and equipped with heavy duty Acme (square) threads for positive action. Adjustment is made by turning the square head with an open end wrench.



MOUNTED BALL BEARINGS

**SEALMASTER®**

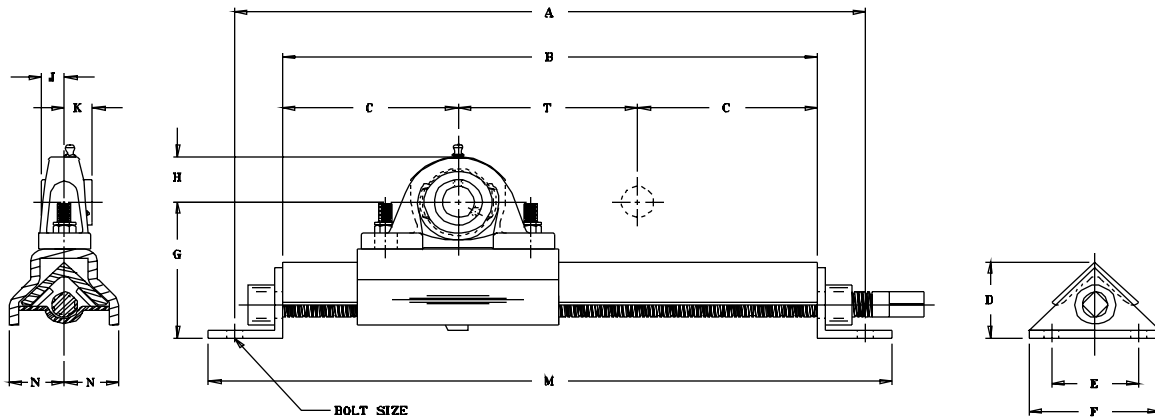

## NPG Series Style "G" Protected Screw Take-Ups...Setscrew Locking

SHAFT DIAM.	PART NO.	BRG. NO.	Dimensions in Inches													BOLT SIZE	UNIT WT.	
			T	A	B	C	D	E	F	G	H	J	K	M	N			O
7/8 15/16 1	NPG-14-6 NPG-15-6 NPG-16-6 NPG-205-6	2-014 2-015 2-1 5205	6	18	15 1/4	4 5/8	2 5/16	2 1/2	3 3/4	4 1/8	1 3/8	9/16	13/16	19 1/2	1 17/32	1/4	3/8	12.4
7/8 15/16 1	NPG-14-9 NPG-15-9 NPG-16-9 NPG-205-9	2-014 2-015 2-1 5205	9	21	18 1/4	4 5/8	2 5/16	2 1/2	3 3/4	4 1/8	1 3/8	9/16	13/16	22 1/2	1 17/32	1/4	3/8	13.5
1 1/8 1 3/16 30	NPG-18-6 NPG-19-6 NPG-206-6	2-12 2-13 5206	6	19	16 1/4	5 1/8	2 5/16	2 1/2	3 3/4	4 3/8	11/16	5/8	7/8	20 1/2	1 23/32	1/4	3/8	16.1
1 1/8 1 3/16 30	NPG-18-9 NPG-19-9 NPG-206-9	2-12 2-13 5206	9	22	19 1/4	5 1/8	2 5/16	2 1/2	3 3/4	4 3/8	11/16	5/8	7/8	23 1/2	1 23/32	1/4	3/8	17.1
1 1/4 1 3/8 1 7/16 35	NPG-20-9 NPG-22-9 NPG-23-9 NPG-207-9	2-14 2-16 2-17 5207	9	22 1/4	19 1/2	5 1/4	2 5/16	2 1/2	3 3/4	4 9/16	1 7/8	11/16	1	23 3/4	1 23/32	1/4	3/8	17.7
1 1/4 1 3/8 1 7/16 35	NPG-20-12 NPG-22-12 NPG-23-12 NPG-207-12	2-14 2-16 2-17 5207	12	25 1/4	22 1/2	5 1/4	2 5/16	2 1/2	3 3/4	4 9/16	1 7/8	11/16	1	26 3/4	1 23/32	1/4	3/8	19.1
1 1/2 1 9/16 40	NPG-24-12 NPG-25-12 NPG-208-12	2-18 2-19 5208	12	26	23 1/4	5 5/8	2 5/16	2 1/2	3 3/4	4 5/8	2	3/4	1 3/16	27 1/2	2 1/16	1/4	3/8	25.6
1 1/2 1 9/16 40	NPG-24-18 NPG-25-18 NPG-208-18	2-18 2-19 5208	18	32	29 1/4	5 5/8	2 5/16	2 1/2	3 3/4	4 5/8	2	3/4	1 3/16	33 1/2	2 1/16	1/4	3/8	27.6
1 5/8 1 11/16 1 3/4 45	NPG-26-12 NPG-27-12 NPG-28-12 NPG-209-12	2-110 2-111 2-112 5209	12	26	23 1/4	5 5/8	2 5/16	2 1/2	3 3/4	4 13/16	2 1/8	3/4	1 3/16	27 1/2	2 1/16	1/4	3/8	24.9
1 5/8 1 11/16 1 3/4 45	NPG-26-18 NPG-27-18 NPG-28-18 NPG-209-18	2-110 2-111 2-112 5209	18	32	29 1/4	5 5/8	2 5/16	2 1/2	3 3/4	4 13/16	2 1/8	3/4	1 3/16	33 1/2	2 1/16	1/4	3/8	28.7

Series NPG and SPG are top mounted protected screw take-up units incorporating standard duty pillow blocks, as indicated in the accompanying charts. They are used where shaft adjustment and/or belt tightening is required in conveyor applications. They are manufactured from heavy gauge structural steel and equipped with heavy duty Acme (square) threads for positive action. Adjustment is made by turning the square head screw with an open end wrench.

Part numbers shown include standard duty pillow block (see page 20).

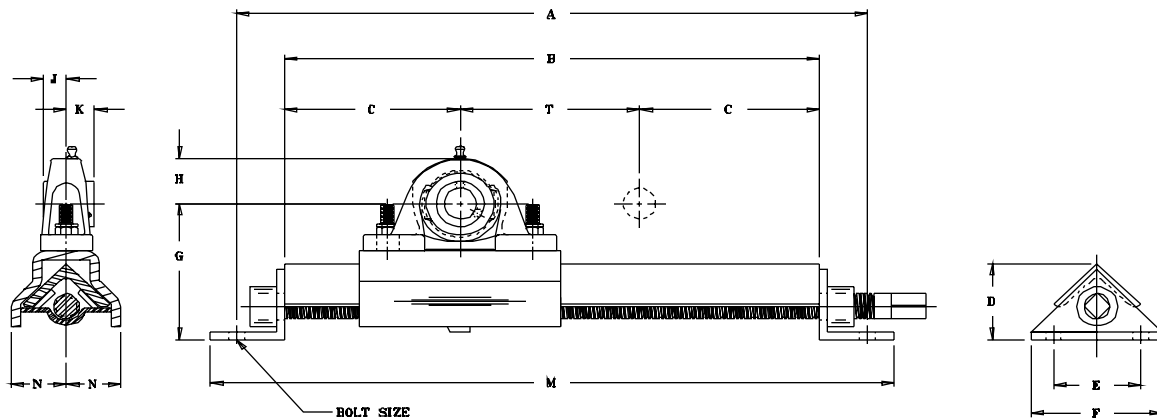

## NPG and SPG Series Style "G" Protected Screw Take-Ups...Setscrew Lock

SHAFT DIAM.	PART NO.	BRG. NO.	Dimensions in Inches														BOLT SIZE	UNIT WT.
			T	A	B	C	D	E	F	G	H	J	K	M	N	O		
1 7/8 1 15/16 50	NPG-30-12 NPG-31-12 NPG-210-12	2-114 2-115 5210	12	26 3/4	24	6	2 5/16	2 1/2	3 3/4	4 15/16	2 5/16	3/4	1 9/32	28 1/4	2 1/16	1/4	12	27.6
1 7/8 1 15/16 50	NPG-30-18 NPG-31-18 NPG-210-18	2-114 2-115 5210	18	32 3/4	30	6	2 5/16	2 1/2	3 3/4	4 15/16	2 5/16	3/4	1 9/32	34 1/4	2 1/16	1/4	12	30.4
2 2 1/8 2 3/16 55	NPG-32-12 NPG-34-12 NPG-35-12 NPG-211-12	2-2 2-22 2-23 5211	12	27 1/4	24 1/2	6 1/4	2 11/16	3	4 3/4	5 9/16	2 1/2	7/8	1 5/16	29	2 7/16	5/16	1/2	36.6
2 2 1/8 2 3/16 55	NPG-32-18 NPG-34-18 NPG-35-18 NPG-211-18	2-2 2-22 2-23 5211	18	33 1/4	30 1/2	6 1/4	2 11/16	3	4 3/4	5 9/16	2 1/2	7/8	1 5/16	35	2 7/16	5/16	1/2	40.1
2 1/4 2 3/8 2 7/16 60	SPG-36-12 SPG-38-12 SPG-39-12 SPG-212-12	2-24 2-26 2-27 5212	12	30	27 1/4	7 5/8	2 11/16	3	4 3/4	6 3/16	2 15/16	1	1 9/16	31 3/4	2 7/16	5/16	5/8	48.9
2 1/4 2 3/8 2 7/16 60	SPG-36-18 SPG-38-18 SPG-39-18 SPG-212-18	2-24 2-26 2-27 5212	18	36	33 1/4	7 5/8	2 11/16	3	4 3/4	6 3/16	2 15/16	1	1 9/16	37 3/4	2 7/16	5/16	5/8	52.1
2 1/2 2 11/16 70	SPG-40-12 SPG-43-12 SPG-214-12	3-28 2-211 5214	12	31 1/2	28 3/4	8 3/8	3 1/4	3	5	7 1/2	3 3/8	1 1/16	1 11/16	33 1/2	2 7/8	3/8	5/8	67.2
2 1/2 2 11/16 70	SPG-40-18 SPG-43-18 SPG-214-18	3-28 2-211 5214	18	37 1/2	34 3/4	8 3/8	3 1/4	3	5	7 1/2	3 3/8	1 1/16	1 11/16	39 1/2	2 7/8	3/8	5/8	69.2
2 7/8 2 15/16 75	SPG-46-12 SPG-47-12 SPG-215-12	2-214 2-215 5215	12	31 1/2	28 3/4	8 3/8	3 1/4	3	5	7 1/2	3 7/16	1 5/16	1 3/4	33 1/2	2 7/8	3/8	5/8	67.6
2 7/8 2 15/16 75	SPG-46-18 SPG-47-18 SPG-215-18	2-214 2-215 5215	18	37 1/2	34 3/4	8 3/8	3 1/4	3	5	7 1/2	3 7/16	1 5/16	1 3/4	39 1/2	2 7/8	3/8	5/8	69.8

Series NPG and SPG are top mounted protected screw take-up units incorporating standard duty pillow blocks, as indicated in the accompanying charts. They are used where shaft adjustment and/or belt tightening is required in conveyor applications. They are manufactured from heavy gauge structural steel and equipped with heavy duty Acme (square) threads for positive action. Adjustment is made by turning the square head screw with an open end wrench.

Part numbers shown include standard duty pillow block NP (see page 20) or SP (see page 24) as indicated.



## Gold Line Solutions for Textile Applications

- Eccentric Locking ensures positive locking without digging into shafting which prevents corrosion initiation.
- Ultra Gard spring Loaded Oil Seals that increase the force between rotating inner race and rubber to tighten seal.  
(See seal description page 188).
- Expansion units provide more shaft growth acceptance than standard expansion units.
- Synthetic High Temperature Grease - increases operating temperature range of bearing to 375°F.

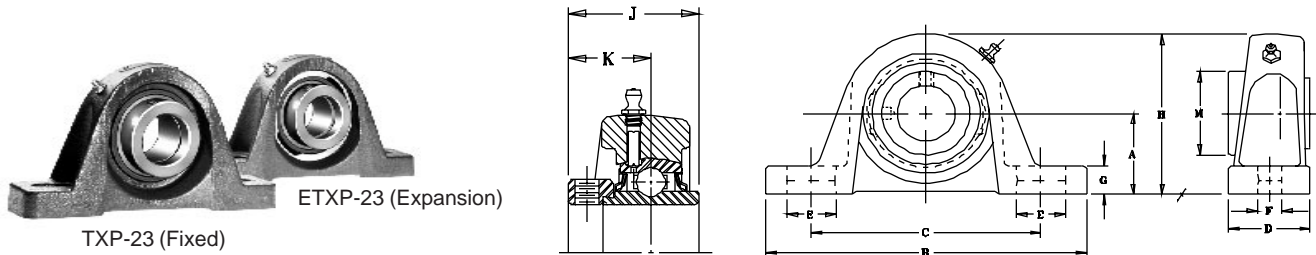

## TXP Series Textile Bearings Pillow Blocks...Eccentric Locking – Fixed

SHAFT DIAM. IN	PART NO.	BRG. NO.	Dimensions in Inches											BOLT SIZE IN.	UNIT WT.	
			A	B	C		D	E	F	G	H	J	K			M
					MIN.	MAX.										
1 7/16	TXP-23	TX-23	2 1/8	7 15/16	5	6 3/8	2 1/32	1 3/16	9/16	3/4	4 3/16	2 1/64	1 9/32	2 3/16	1/2	7.1
2 3/16	TXP-35	TX-35	2 3/4	10 1/4	6 9/16	7 15/16	3 1/8	1 7/16	13/16	1 1/16	5 5/8	2 13/16	1 23/32	3	3/4	16-2
2 7/16	TXP-39	TX-39	3	11 1/4	7 1/8	8 7/8	3 1/4	1 5/8	13/16	1 1/16	6 1/4	3 1/16	1 27/32	3 3/8	3/4	21.5

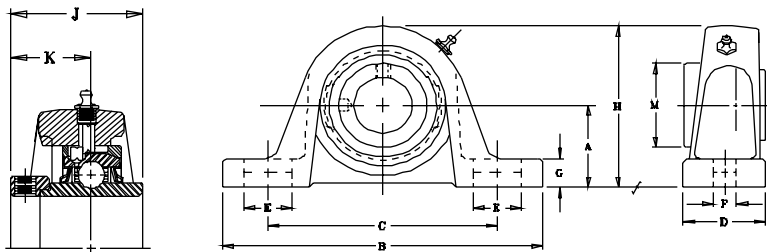

## ETXP Series Textile Bearings Pillow Blocks...Eccentric Locking – Expansion

SHAFT DIAM. IN	PART NO.	BRG. NO. AR-	Dimensions in Inches											LIMIT OF EXPANSION	BOLT SIZE IN.	UNIT WT.	
			A	B	C		D	E	F	G	H	J	K				M
					MIN.	MAX.											
1 7/16	ETXP-23	ETX-23	2 1/8	7 15/16	5	6 3/8	2 1/32	1 3/16	9/16	3/4	4 3/16	2 1/64	1 9/32	2 3/16	3/16	1/2	6.8
2 3/16	ETXP-35	ETX-35	2 3/4	10 1/4	6 9/16	7 15/16	3 1/8	1 7/16	13/16	1 1/16	5 5/8	2 13/16	1 23/32	3	3/8	3/4	15.6
2 7/16	ETXP-39	ETX-39	3	11 1/4	7 1/8	8 7/8	3 1/4	1 5/8	13/16	1 1/16	6 1/4	3 1/16	1 27/32	3 3/8	3/8	3/4	20.0

# SEALMASTER® MOUNTED BALL BEARINGS

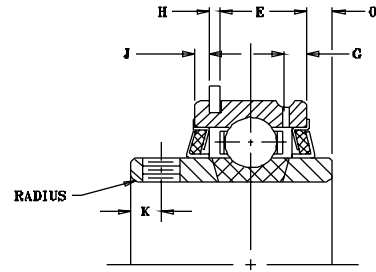
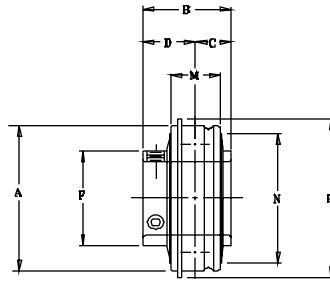

## ER Series Style "A" Extended Inner Ring Bearing Assemblies...Setscrew Locking

SHAFT DIAM.		BRG. NO.	Dimensions in Inches														UNIT WT.	
IN	MM		A	B	C	D	E	F	G	H	J	K	M	N	RAD	O		P
1/2		ER-8																
9/16		ER-9																
5/8		ER-10	47MM															
11/16		ER-11	1.8504	1 7/32	13/32	13/16	31/64	1 3/16	11/64	3/64	3/32	3/16	5/8	1 5/8	.040	.094	2 1/16	.56
3/4	20	ER-12																
		ER-204																
7/8		ER-14																
15/16		ER-15	52MM															
1	25	ER-16	2.0472	1 3/8	33/64	55/64	39/64	1 3/8	13/64	3/64	3/32	7/32	3/4	1 55/64	.040	.135	2 17/64	.68
		ER-205																
1 1/16		ER-17																
1 1/8		ER-18	62MM															
1 3/16		ER-19	2.4409	1 1/2	5/8	7/8	11/16	1 19/32	7/32	1/16	1/8	7/32	7/8	2 5/32	.040	.188	2 21/32	.93
1 1/4	30	ER-20R																
		ER-206																
1 1/4		ER-20																
1 5/16		ER-21	72MM															
1 3/8		ER-22	2.8346	1 11/16	11/16	1	3/4	1 55/64	7/32	1/16	1/8	1/4	15/16	2 17/32	.040	.219	3 5/64	1.37
1 7/16	35	ER-23																
		ER-207																
1 1/2		ER-24	80MM															
1 9/16	40	ER-25	3.1496	1 15/16	3/4	1 3/16	29/32	2 1/16	1/4	1/16	1/8	5/16	1 3/32	2 53/64	.062	.203	3 13/32	2.00
		ER-208																
1 5/8		ER-26																
1 11/16		ER-27	85MM															
1 3/4	45	ER-28	3.3465	1 15/16	3/4	1 3/16	29/32	2 19/64	1/4	1/16	1/8	5/16	1 3/32	3 1/16	.062	.203	3 19/32	2.31
		ER-209																
1 13/16		ER-29																
1 7/8		ER-30	90MM															
1 15/16		ER-31	3.5433	2 1/32	3/4	1 9/32	29/32	2 15/32	19/64	3/32	1/8	3/8	1 1/8	3 7/32	.062	.188	3 25/32	2.43
2	50	ER-32R																
		ER-210																
2		ER-32																
2 1/8		ER-34	100MM															
2 3/16	55	ER-35	3.9370	2 3/16	7/8	1 5/16	31/32	2 23/32	19/64	3/32	1/8	3/8	1 3/16	3 9/16	.080	.281	4 3/16	3.00
		ER-211																
2 1/4		ER-36																
2 3/8		ER-38	110MM															
2 7/16	60	ER-39	4.3307	2 9/16	1	1 9/16	1 1/32	2 63/64	19/64	3/32	1/8	7/16	1 1/4	3 29/32	.080	.375	4 19/32	4.00
		ER-212																
2 1/2		ER-40																
2 11/16	70	ER-43	125MM															
		ER-214	4.9213	2 3/4	1 1/16	1 11/16	1 7/64	3 7/16	5/16	7/64	5/32	7/16	1 3/8	4 7/16	.080	.375	5 9/32	5.56
2 7/8		ER-46																
2 15/16	75	ER-47	130MM															
		ER-215	5.1181	3 1/16	1 5/16	1 3/4	1 15/64	3 41/64	3/8	7/64	5/32	7/16	1 1/2	4 5/8	.080	.563	5 1/2	6.37
3		ER-48																
3 3/16	80	ER-51	140MM															
		ER-216	5.5118	3 1/4	1 5/16	1 15/16	1 25/64	3 59/64	7/16	7/64	3/16	17/32	1 11/16	4 63/64	.120	.469	5 7/8	7.85
3 1/4		ER-52																
3 3/8		ER-54	150MM															
3 7/16		ER-55	5.9055	3 3/8	1 11/32	2 1/32	1 41/64	4 5/32	7/16	7/64	3/16	15/32	1 15/16	5 19/64	.120	.375	6 9/32	9.50
3 15/16		ER-63																
4		ER-64	190MM															
			7.4803	4 5/8	1 15/16	2 11/16	2 5/32	5 11/64	11/16	1/8	7/32	3/4	2 1/2	6 21/32	.120	.688	8	22.0

For Load Ratings, see page 45.

See page 75 for Table on guide for matching housings using the "ER" style "A" Extended Inner Ring Bearing.

Felt seal standard. For contact seal add suffix "C" ER-16C.





MOUNTED BALL BEARINGS

**SEALMASTER®**

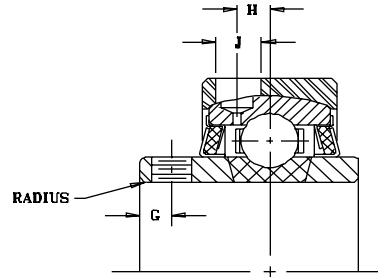
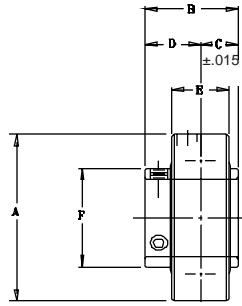

## AR Series Standard Duty Expansion Units...Setscrew Locking

SHAFT DIAM.		BRG. NO.	Dimensions in Inches									SET SCREW TAP	UNIT WT.	
			*A	B	C	D	E	F	G	H	J			RADIUS
IN	MM													
1/2 9/16 5/8 11/16 3/4	20	AR-2-08 AR-2-09 AR-2-010 AR-2-011 AR-2-012 AR-204	2.062	1 7/32	1/2	23/32	49/64	1 3/16	3/16	9/64	1/4	.040	1/4-28	.8
13/16 7/8 15/16 1	25	AR-2-013 AR-2-014 AR-2-015 AR-2-1 AR-205	2.272	1 3/8	9/16	13/16	49/64	1 3/8	7/32	11/64	1/4	.040	1/4-28	1.0
1 1/16 1 1/8 1 3/16 1 1/4	30	AR-2-11 AR-2-12 AR-2-13 AR-1-14 AR-206	2.687	1 1/2	5/8	7/8	61/64	1 19/32	7/32	7/32	1/4	.040	1/4-28	1.5
1 1/4 1 5/16 1 3/8 1 7/16	35	AR-2-14 AR-2-15 AR-2-16 AR-2-17 AR-207	3.140	1 11/16	11/16	1	1 1/64	1 55/64	1/4	1/4	1/4	.040	5/16-24	2.1
1 1/2 1 9/16	40	AR-2-18 AR-2-19 AR-208	3.375	1 15/16	3/4	1 3/16	1 11/64	2 1/16	5/16	19/64	1/4	.062	5/16-24	2.8
1 5/8 1 11/16 1 3/4	45	AR-2-110 AR-2-111 AR-2-112 AR-209	3.562	1 15/16	3/4	1 3/16	1 11/64	2 19/64	5/16	19/64	1/4	.062	5/16-24	3
1 13/16 1 7/8 1 15/16 2	50	AR-2-113 AR-2-114 AR-2-115 AR-1-2 AR-210	3.875	2-1/32	3/4	1 9/32	1 13/64	2 15/32	3/8	17/64	11/32	.062	3/8-24	3.5
2 2 1/8 2 3/16	55	AR-2-2 AR-2-22 AR-2-23 AR-211	4.250	2 3/16	7/8	1 5/16	1 17/64	2 23/32	3/8	19/64	11/32	.080	3/8-24	4.4
2 1/4 2 3/8 2 7/16	60	AR-2-24 AR-2-26 AR-2-27 AR-212	4.718	2 9/16	1	1 9/16	1 21/64	2 63/64	7/16	21/64	11/32	.080	3/8-24	5.8
2 11/16	70	AR-2-211 AR-214	5.170	2 3/4	1 1/16	1 11/16	1 29/64	3 7/16	7/16	3/8	11/32	.080	7/16-20	9.3
2 7/8 2 15/16	75	AR-2-214 AR-2-215 AR-215	5.375	3 1/16	1 5/16	1 3/4	1 37/64	3 41/64	7/16	3/8	11/32	.080	7/16-20	9.6
3 3/16	80	AR-2-33 AR-216	5.875	3 1/4	1 5/16	1 15/16	1 53/64	3 59/64	17/32	13/32	15/32	.120	7/16-20	12.2
3 1/4 3 3/8 3 7/16		AR-2-34 AR-2-36 AR-2-37	6.280	3 3/8	1 11/32	2 1/32	2 5/64	4 5/32	15/32	17/32	15/32	.120	7/16-20	15.2
3 1/2	90	AR-2-38 AR-218	6.750	3 25/32	1 9/16	2 7/32	2 9/64	4 25/64	5/8	15/32	15/32	.120	1/2-20	18.5

For Load Ratings, see page 45.

\*Tolerance +.000", -.005"

Felt seal standard. For contact seal add suffix "C" (AR-2-1C).

# SEALMASTER® MOUNTED BALL BEARINGS

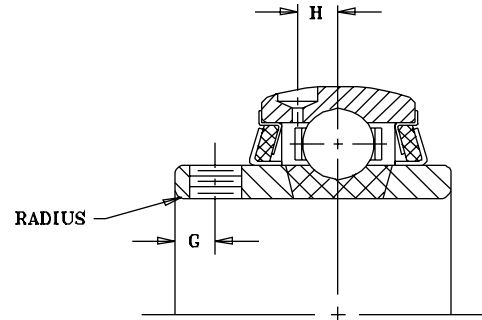
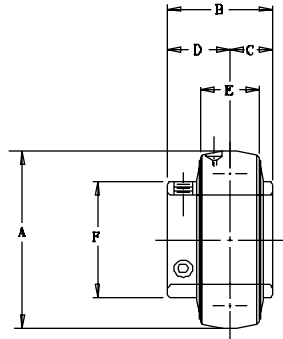

## Standard Duty Bearing Inserts...Setscrew Locking – Single Lock

SHAFT DIAM.		BRG. NO.	Dimensions in Inches									SET SCREW TAP	UNIT WT.
			A	B	C	D	E	F	G	H	RADIUS		
1/2 9/16 5/8 11/16 3/4	20	2-08 2-09 2-010 2-011 2-012 5204	47MM 1.8504	1 7/32	1/2	23/32	5/8	1 3/16	3/16	9/64	.040	1/4-28	.5
13/16 7/8 15/16 1	25	2-013 2-014 2-015 2-1 5205	52MM 2.0472	1 3/8	9/16	13/16	11/16	1 3/8	7/32	11/64	.040	1/4-28	.6
1 1/16 1 1/8 1 3/16 1 1/4	30	2-11 2-12 2-13 1-14 5206	62MM 2.4409	1 1/2	5/8	7/8	7/8	1 19/32	7/32	7/32	.040	1/4-28	1.0
1 1/4 1 5/16 1 3/8 1 7/16	35	2-14 2-15 2-16 2-17 5207	72MM 2.8346	1 11/16	11/16	1	15/16	1 55/64	1/4	1/4	.040	5/16-24	1.5
1 1/2 1 9/16	40	2-18 2-19 5208	80MM 3.1496	1 15/16	3/4	1 3/16	1 3/32	2 1/16	5/16	19/64	.062	5/16-24	1.9
1 5/8 1 11/16 1 3/4	45	2-110 2-111 2-112 5209	85MM 3.3465	1 15/16	3/4	1 3/16	1 3/32	2 19/64	5/16	19/64	.062	5/16-24	2.2
1 13/16 1 7/8 1 15/16 2	50	2-113 2-114 2-115 1-2 5210	90MM 3.5433	2 1/32	3/4	1 9/32	1 1/8	2 15/32	3/8	17/64	.062	3/8-24	2.4
2 2 1/8 2 3/16	55	2-2 2-22 2-23 5211	100MM 3.9370	2 3/16	7/8	1 5/16	1 3/16	2 23/32	3/8	19/64	.080	3/8-24	2.8
2 1/4 2 3/8 2 7/16	60	2-24 2-26 2-27 5212	110MM 4.3307	2 9/16	1	1 9/16	1 1/4	2 63/64	7/16	21/64	.080	3/8-24	3.7
2 11/16	70	2-211 5214	125MM 4.9213	2 3/4	1 1/16	1 11/16	1 3/8	3 7/16	7/16	3/8	.080	7/16-20	5.8
2 7/8 2 15/16	75	2-214 2-215 5215	130MM 5.1181	3 1/16	1 5/16	1 3/4	1 1/2	3 41/64	7/16	3/8	.080	7/16-20	6.8
3 3/16	80	2-33 5216	140MM 5.5118	3 1/4	1 5/16	1 15/16	1 11/16	3 59/64	17/32	13/32	.120	7/16-20	7.2
3 1/4 3 3/8 3 7/16		2-34 2-36 2-37	150MM 5.9055	3 3/8	1 11/32	2 1/32	1 15/16	4 5/32	15/32	17/32	.120	7/16-20	9.3
3 1/2	90	2-38 5218	160MM 6.2992	3 25/32	1 9/16	2 7/32	2	4 25/64	5/8	15/32	.120	1/2-20	11.7

Felt seal standard. For contact seal add suffix "C" (2-1C).  
For Load Ratings, see page 45.

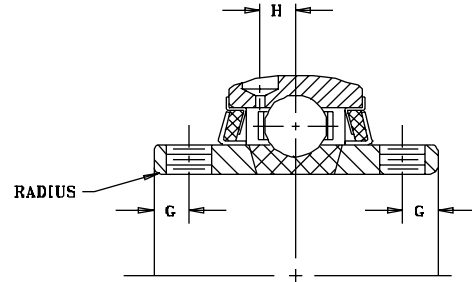
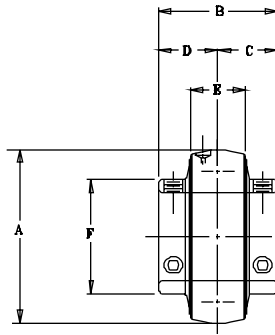

**Standard Duty Bearing Inserts...Setscrew Locking – Double Lock**

SHAFT DIAM.	BRG. NO.	Dimensions in Inches									SET SCREW TAP	UNIT WT.
		A	B	C	D	E	F	G	H	RADIUS		
7/8 15/16 1	2-014D 2-015D 2-1D	52MM 2.0472	1 1/2	3/4	3/4	11/16	1 3/8	7/32	11/64	.040	1/4-28	.6
1 1/16 1 1/8 1 3/16	2-11D 2-12D 2-13D	62MM 2.4409	1 3/4	7/8	7/8	7/8	1 19/32	7/32	7/32	.040	1/4-28	1.0
1 1/4 1 5/16 1 3/8 1 7/16	2-14D 2-15D 2-16D 2-17D	72MM 2.8346	2	1	1	15/16	1 55/64	1/4	1/4	.040	5/16-24	1.5
1 1/2 1 9/16	2-18D 2-19D	80MM 3.1496	2 5/16	1 5/32	1 5/32	1 3/32	2 1/16	5/16	19/64	.062	5/16-24	1.9
1 5/8 1 11/16 1 3/4	2-110D 2-111D 2-112D	85MM 3.3465	2 3/8	1 3/16	1 3/16	1 3/32	2 19/64	11/32	19/64	.062	5/16-24	2.2
1 7/8 1 15/16	2-114D 2-115D	90MM 3.5433	2 1/2	1 1/4	1 1/4	1 1/8	2 15/32	11/32	17/64	.062	3/8-24	2.4
2 2 1/8 2 3/16	2-2D 2-22D 2-23D	100MM 3.9370	2 5/8	1 5/16	1 5/16	1 3/16	2 23/32	5/16	19/64	.080	3/8-24	2.8
2 1/4 2 3/8 2 7/16	2-24D 2-26D 2-27D	110MM 4.3307	3 1/8	1 9/16	1 9/16	1 1/4	2 63/64	13/32	21/64	.080	3/8-24	3.7
2 11/16	2-211D	125MM	3 1/2	1 3/4	1 3/4	1 3/8	3 7/16	15/32	3/8	.080	7/16-20	5.8
2 7/8 2 15/16	2-214D 2-215D	130MM	3 1/2	1 3/4	1-3/4	1 1/2	3 41/64	7/16	3/8	.080	7/16-20	6.8
3 3/16	2-33D	140MM	3 7/8	1 15/16	1 15/16	1 11/16	3 59/64	9/16	13/32	.120	7/16-20	7.2
3 1/4 3 3/8 3 7/16	2-34D 2-36D 2-37D	150MM 5.9055	4 1/16	2 1/32	2 1/32	1 15/16	4 5/32	1/2	17/32	.120	7/16-20	9.3
3 1/2	2-38D	160MM	4 7/16	2 7/32	2 7/32	2	4 25/64	1/2	15/32	.120	1/2-20	11.7

Double Lock bearing inserts incorporate extended inner races on both sides of the ball path for better load distribution along the shaft. Each extension has 2 locking setscrews, a total of 4 per insert. The ball path is zone hardened with the extensions left soft for positive race-to-shaft locking. The outer ring has a dimple for use with a locking pin to prevent outer race rotation. Double lock units have higher speed capabilities. (See load rating tables page 45).

# LOAD RATING TABLES - Normal Duty

The shaded area indicates the maximum speed ratings for double lock bearings (applicable on sizes available). All speeds listed are for the standard felt seal. See the seal selection for alternate seals.

Values in the table represent loads at ideal conditions with press fit mounting to the shaft. ABMA recommends de-rating of slip mounted bearings. To obtain de-rated load, divide load in table by 1.3. Values in the table represent equivalent radial loads only. For combined load determination, see **THE BEARING SELECTION SECTION**. Areas designated by "-" exceeds maximum value for standard bearings. Consult Sealmaster Application Engineering for load and speed applications not covered in this table.

NORMAL DUTY			REVOLUTIONS PER MINUTE																
SHAFT SIZE	INSERT #	ER #	L10 HOURS	50	150	500	1000	1750	2000	2500	3500	4500	5000	5500	6000	6500	7500	8000	10000
1/2	2-08	ER-8	5000	619	619	491	390	324	310	287	257	236	228	221	215	209	199	195	181
9/16	2-09	ER-9	10000	583	583	390	310	257	246	228	204	188	181	175	170	166	158	154	143
5/8	2-010	ER-10	30000	583	404	270	215	178	170	158	141	130	126	122	118	115	109	107	100
11/16	2-011	ER-11	50000	491	341	228	181	150	144	133	119	110	106	103	100	97	92	90	84
3/4	2-012	ER-12	100000	390	270	181	144	119	114	106	95	87	84	81	79	77	73	71	67
20mm	5204	ER-204																	
1 3/16	2-013		5000	664	664	527	418	347	332	308	276	253	245	237	230	224	213	213	-
7/8	2-014	ER-14	10000	625	625	418	332	276	264	245	219	201	194	188	183	177	169	169	-
15/16	2-015	ER-15	30000	625	433	290	230	191	183	170	152	139	135	130	127	123	117	117	-
25mm	5205	ER-205	50000	527	366	245	194	161	154	143	128	118	114	110	107	104	99	99	-
1	2-1	ER-16	100000	418	290	194	154	128	122	114	102	93	90	87	85	82	78	78	-
1 1/16	2-11	ER-17	5000	1039	1039	825	654	543	519	482	431	396	383	370	360	351	334	334	-
1 1/8	2-12	ER-18	10000	978	978	654	519	431	412	383	342	315	304	294	286	278	265	265	-
1 3/16	2-13	ER-19	30000	978	678	454	360	299	286	265	237	218	211	204	198	193	184	184	-
30mm	5206	ER-206	50000	825	572	383	304	252	241	224	200	184	178	172	167	163	155	155	-
1 1/4R	1-14		100000	654	454	304	241	200	191	178	159	146	141	136	133	129	123	123	-
1 1/4	2-14	ER-20	5000	1290	1290	1088	864	717	686	636	569	523	505	489	475	463	-	-	-
1 5/16	2-15	ER-21	10000	1290	1290	864	686	569	544	505	452	415	401	388	377	367	-	-	-
1 3/8	2-16	ER-22	30000	1290	895	599	475	394	377	350	313	288	278	269	262	255	-	-	-
35mm	5207	ER-207	50000	1088	755	505	401	333	318	295	264	243	234	227	221	215	-	-	-
1 7/16	2-17	ER-23	100000	864	599	401	318	264	253	234	210	193	186	180	175	171	-	-	-
1 1/2	2-18	ER-24	5000	1638	1638	1381	1096	910	870	808	722	664	641	621	603	-	-	-	-
1 9/16	2-19	ER-25	10000	1638	1638	1096	870	722	691	641	573	527	509	493	479	-	-	-	-
40mm	5208	ER-208	30000	1638	1136	760	603	501	479	445	397	365	353	342	332	-	-	-	-
			50000	1381	958	641	509	422	404	375	335	308	298	288	280	-	-	-	-
			100000	1096	760	509	404	335	321	298	266	245	236	229	222	-	-	-	-
1 5/8	2-110	ER-26	5000	1763	1763	1487	1180	979	937	870	777	715	690	669	-	-	-	-	-
1 11/16	2-111	ER-27	10000	1763	1763	1180	937	777	744	690	617	567	548	531	-	-	-	-	-
1 3/4	2-112	ER-38	30000	1763	1222	818	650	539	516	479	428	393	380	368	-	-	-	-	-
45mm	5209	ER-209	50000	1487	1031	690	548	455	435	404	361	332	320	310	-	-	-	-	-
			100000	1180	818	548	435	361	345	320	286	263	254	246	-	-	-	-	-
1 13/16	2-113		5000	1760	1760	1485	1178	978	935	868	776	714	689	-	-	-	-	-	-
1 7/8	2-114	ER-30	10000	1760	1760	1178	935	776	742	689	616	567	547	-	-	-	-	-	-
1 15/16	2-115	ER-31	30000	1760	1221	817	649	538	515	478	427	393	379	-	-	-	-	-	-
50mm	5210	ER-210	50000	1485	1029	689	547	454	434	403	360	331	320	-	-	-	-	-	-
	1-2		100000	1178	817	547	434	360	345	320	286	263	254	-	-	-	-	-	-
2	2-2	ER-32	5000	2176	2176	1835	1457	1209	1156	1073	1010	959	-	-	-	-	-	-	-
2 1/8	2-22	ER-34	10000	2176	2176	1457	1156	959	918	852	802	762	-	-	-	-	-	-	-
55mm	5211	ER-211	30000	2176	1509	1010	802	665	636	591	556	528	-	-	-	-	-	-	-
2 3/16	2-23	ER-35	50000	1835	1273	852	676	561	537	498	469	445	-	-	-	-	-	-	-
			100000	1457	1010	676	537	445	426	395	372	353	-	-	-	-	-	-	-
NORMAL DUTY			REVOLUTIONS PER MINUTE																
SHAFT SIZE	INSERT #	ER #	L10 HOURS	50	150	250	500	750	1000	1250	1500	1750	2000	2500	3000	3500	4000	4500	-
2 1/4	2-24	ER-36	5000	2631	2631	2631	2219	1938	1761	1635	1538	1461	1398	1298	1221	1160	1109	-	-
2 5/16	2-25		10000	2631	2631	2219	1761	1538	1398	1298	1221	1160	1109	1030	969	921	881	-	-
60mm	5212	ER-212	30000	2631	1824	1538	1221	1067	969	900	847	804	769	714	672	638	611	-	-
2 3/8	2-26	ER-38	50000	2219	1538	1298	1030	900	817	759	714	678	649	602	567	538	515	-	-
2 7/16	2-27	ER-39	100000	1761	1221	1030	817	714	649	602	567	538	515	478	450	427	409	-	-
2 1/2			5000	3118	3118	3118	2629	2297	2087	1937	1823	1732	1656	1538	1447	1375	-	-	-
2 11/16	2-211	ER-43	10000	3118	3118	2629	2087	1823	1656	1538	1447	1375	1315	1220	1149	1091	-	-	-
70mm	5214	ER-214	30000	3118	2162	1823	1447	1264	1149	1066	1003	953	912	846	796	756	-	-	-
			50000	2629	1823	1538	1220	1066	969	899	846	804	769	714	672	638	-	-	-
			100000	2087	1447	1220	969	846	769	714	672	638	610	567	533	506	-	-	-
2 7/8	2-214	ER-46	5000	3311	3311	3311	2793	2440	2217	2058	1936	1839	1759	1633	1537	1460	-	-	-
2 15/16	2-215	ER-47	10000	3311	3311	2793	2217	1936	1759	1633	1537	1460	1396	1296	1220	1159	-	-	-
75mm	5215	ER-215	30000	3311	2296	1936	1537	1343	1220	1132	1066	1012	968	899	846	803	-	-	-
			50000	2793	1936	1633	1296	1132	1029	955	899	854	817	758	713	678	-	-	-
			100000	2217	1537	1296	1029	899	817	758	713	678	648	602	566	538	-	-	-
3			5000	3885	3885	3885	3277	2863	2601	2415	2272	2158	2064	1916	1803	-	-	-	-
80mm	5216	ER-216	10000	3885	3885	3277	2601	2272	2064	1916	1803	1713	1639	1521	1431	-	-	-	-
3 3/16	2-33	ER-51	30000	3885	2694	2272	1803	1575	1431	1329	1250	1188	1136	1055	992	-	-	-	-
			50000	3277	2272	1916	1521	1329	1207	1121	1055	1002	985	890	837	-	-	-	-
			100000	2601	1803	1521	1207	1055	958	890	837	795	761	706	664	-	-	-	-
3 1/4	2-34	ER-52	5000	3975	3975	3975	3516	3071	2791	2591	2438	2316	2215	2056	1935	-	-	-	-
3 3/8	2-36	ER-54	10000	3975	3975	3516	2791	2438	2215	2056	1935	1838	1758	1632	1536	-	-	-	-
3 7/16	2-37	ER-55	30000	3975	2890	2438	1935	1690	1536	1426	1342								

# Medium Duty Bearings Designed For Higher Load Ratings

SEALMASTER® Gold Line Medium Duty Bearings, designed for heavier industrial applications, are shown and described in the dimension and specification pages 47-61 which follow for setscrew designs, and pages 79-83 for SKWEZLOC® locking collar designs.

## Medium Duty Bearings Are Offered In The Following Series:



### Pillow Blocks, Two-Bolt Base

- with Setscrew Locking in both single and double locking designs.
- With SKWEZLOC Locking Collars.



### Expansion Type Pillow Blocks, Two- Bolt Base

- with Setscrew Locking, single locking designs.
- with SKWEZLOC Locking Collars.



### Pillow Blocks, Four-Bolt Base

- with Setscrew Locking in both single and double locking designs.



### Take-Up Units

- with Setscrew Locking, single locking designs.
- with SKWEZLOC Locking Collar designs.



### Four-Bolt Flange Units

- with Setscrew Locking, single locking designs.
- with SKWEZLOC Locking Collar designs.



### Two-Bolt Flange Units

- with Setscrew Locking, single locking designs.
- with SKWEZLOC Locking Collar designs.



### Flange Cartridge Units (Cylindrical Cartridges)

- with Setscrew Locking, single locking designs.
- with SKWEZLOC Locking Collar designs.



### Expansion Units (Cylindrical Cartridges)

- with Setscrew Locking, single locking designs.



### Expansion Units (Cylindrical Cartridges)

- with SKWEZLOC Locking designs.



### Bearing Inserts

- with Setscrew Locking in both single and double locking designs.



### Bearing Inserts

- with SKWEZLOC Locking Collar designs.

The Load Rating Tables for all Medium Duty Bearings Units with Setscrew Single and Double Lock are on page 62.

Medium Duty Bearings have the same general features and benefits as the Standard Duty Units. These units may be further modified to meet unusual operating or ambient conditions. Consult our Engineering Department for specific recommendations.

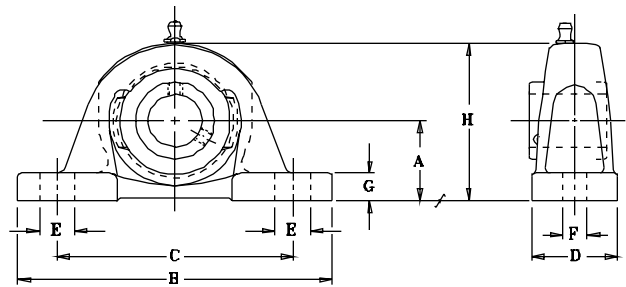
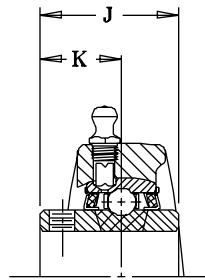

## MP Series Medium Duty Pillow Blocks...Setscrew Locking

SHAFT DIAM.	PART NO.	BRG. NO.	Dimensions In Inches											BOLT SIZE IN.	UNIT WT.
			A	B	C		D	E	F	G	H	J	K		
IN	MM				MIN.	MAX.									
1 15/16 1	MP-15 MP-16 MP-305	3-015 3-1 5305	1 3/4	6 1/4	4 3/16	5 3/16	2	1	9/16	5/8	3 7/16	1 1/2	7/8	1/2	4.0
1 3/16 1 1/4 30	MP-19 MP-20 MP-306	3-13 2-14 5306	1 7/8	6 7/8	4 1/2	5 1/2	2 1/4	1	9/16	11/16	3 13/16	1 11/16	1	1/2	5.4
1 7/16 35	MP-23 MP-307	3-17 5307	2 1/8	8	5	6 3/8	2 1/4	1 3/16	9/16	3/4	4 3/16	1 15/16	1 3/16	1/2	6.8
1 1/2 40	MP-24 MP-308	3-18 5308	2 5/16	8 3/4	5 1/2	6 3/4	2 5/8	1 1/4	11/16	13/16	4 9/16	1 15/16	1 3/16	5/8	9.0
1 11/16 1 3/4 45	MP-27 MP-28 MP-309	3-111 3-112 5309	2 5/16	8 3/4	5 7/16	6 13/16	2 5/8	1 5/16	11/16	13/16	4 5/8	2 1/32	1 9/32	5/8	9.5
1 15/16 2 50	MP-31 MP-32 MP-310	3-115 2-2 5310	2 1/2	9 1/2	5 15/16	7 9/16	2 7/8	1 7/16	11/16	7/8	5 3/32	2 3/16	1 5/16	5/8	11.7
2 3/16 2 1/4 55	MP-35 MP-36 MP-311	3-23 2-24 5311	2 3/4	10 1/4	6 9/16	7 15/16	3 1/8	1 7/16	13/16	1 1/16	5 5/8	2 9/16	1 9/16	3/4	16.2
2 7/16 2 1/2 65	MP-39 MP-40 MP-313	3-27 3-28 5313	3	11 1/4	7 1/8	8 7/8	3 1/4	1 5/8	13/16	1 1/16	6 1/4	2 3/4	1 11/16	3/4	21.5
2 11/16 70	MP-43 MP-314	3-211 5314	3 1/2	13	7 7/8	10 1/8	3 1/2	2	15/16	1 1/8	7	3 1/16	1 3/4	7/8	29.2
2 15/16 3 75	MP-47 MP-48 MP-315	3-215 3-3 5315	3 1/2	13	7 7/8	10 1/8	3 1/2	2	15/16	1 1/4	7 1/4	3 1/4	1 15/16	7/8	31.5
3 3/16 3 1/4 80	MP-51 MP-52 MP-316	3-33 2-34 5316	4	15	9 11/16	12 9/16	4	2 5/16	15/16	1 1/4	8	3 3/8	2 1/32	7/8	44.1
3 7/16 3 1/2	MP-55 MP-56	3-37 2-38	4	15	9 5/8	12 5/8	4 3/8	2 3/8	15/16	1 5/16	8 1/4	3 25/32	2 7/32	7/8	47.8
3 15/16 4 100	MP-63 MP-64 MP-320	3-315 3-4 5320	5	17	11 3/4	14 3/4	4 3/4	2 1/2	1 1/8	1 5/16	10	4 5/8	2 11/16	1	73.2

For Load Ratings, see page 62.

For Medium Duty Bearing Inserts-Single Lock, see page 60.

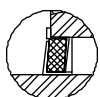

**Felt Seal Standard**  
Positive sealing for low, medium, and high speed operation.



**Single Lip Contact Seal**  
Available on all sizes. Recommended where moisture conditions prevail. To specify, add suffix "C" (MP-32C).

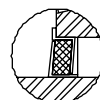

**Hi-Temp Seal**  
Available as an option where operating temperatures are in 250-400° range. (See seal options on page 188).



MOUNTED BALL BEARINGS

**SEALMASTER®**

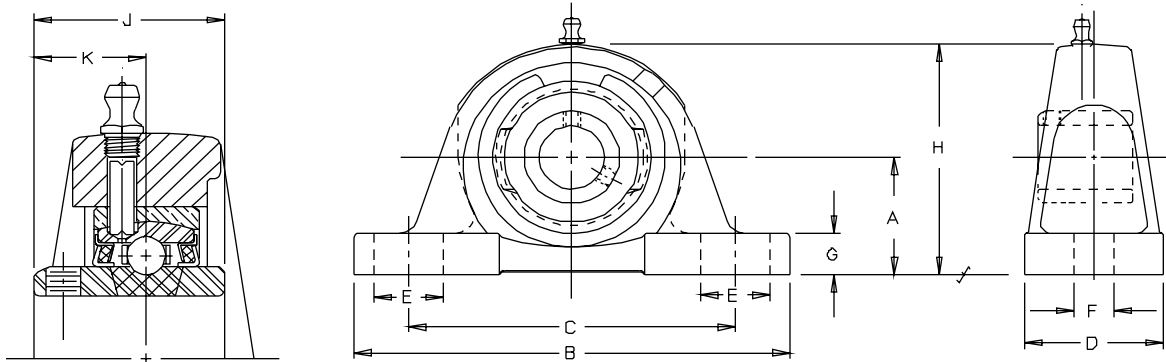

## EMP Series Expansion Type Pillow Blocks...Setscrew Locking

SHAFT DIAM. IN MM	PART NO.	BRG. NO.	Dimensions In Inches											LIMIT OF EXPAN.	BOLT SIZE IN.	UNIT WT.
			A	B	C		D	E	F	G	H	J	K			
					MIN.	MAX.										
15/16 1 25	EMP-15 EMP-16 EMP-205	AR-2-015 AR-2-1 AR-5205	1 3/4	6 1/4	4 3/16	5 3/16	2	1	9/16	5/8	3 7/16	1 3/8	13/16	1/8	1/2	3.7
1 3/16 30	EMP-19 EMP-206	AR-2-13 AR-5206	1 7/8	6 7/8	4 1/2	5 1/2	2 1/4	1	9/16	11/16	3 13/16	1 1/2	7/8	1/8	1/2	5.5
1 7/16 35	EMP-23 EMP-207	AR-2-17 AR-5207	2 1/8	8	5	6 3/8	2 1/4	1 3/16	9/16	3/4	4 3/16	1 11/16	1	1/8	1/2	6.8
1 1/2 40	EMP-24 EMP-208	AR-2-18 AR-5208	2 5/16	8 3/4	5 1/2	6 3/4	2 5/8	1 1/4	11/16	13/16	4 9/16	1 15/16	1 3/16	1/8	5/8	9.0
1 11/16 45	EMP-27 EMP-209	AR-2-111 AR-5209	2 5/16	8 3/4	5 7/16	6 13/16	2 5/8	1 5/16	11/16	13/16	4 5/8	1 15/16	1 3/16	1/8	5/8	9.2
1 15/16 50	EMP-31 EMP-210	AR-2-115 AR-5210	2 1/2	9 1/2	5 15/16	7 9/16	2 7/8	1 7/16	11/16	7/8	5 3/32	2 1/32	1 9/32	3/16	5/8	11.6
2 3/16 55	EMP-35 EMP-211	AR-2-23 AR-5211	2 3/4	10 1/4	6 9/16	7 15/16	3 1/8	1 7/16	13/16	1 1/16	5 5/8	2 3/16	1 5/16	3/16	3/4	15.6
2 7/16	EMP-39	AR-2-27	3	11 1/4	7 1/8	8 7/8	3 1/4	1 5/8	13/16	1 1/16	6 1/4	2 9/16	1 9/16	3/16	3/4	20.0
2 11/16 70	EMP-43 EMP-214	AR-2-211 AR-5214	3 1/2	13	7 7/8	10 1/8	3 1/2	2	15/16	1 1/8	7	2 3/4	1 11/16	3/16	7/8	29.1
2 15/16 75	EMP-47 EMP-215	AR-2-215 AR-5215	3 1/2	13	7 7/8	10 1/8	3 1/2	2	15/16	1 1/4	7 1/4	3 1/16	1 3/4	3/16	7/8	30.7
3 3/16 80	EMP-51 EMP-216	AR-2-33 AR-5216	4	15	9 11/16	12 9/16	4	2 5/16	15/16	1 1/4	8	3 1/4	1 15/16	9/32	7/8	41.8
3 7/16	EMP-55	AR-2-37	4	15	9 5/8	12 5/8	4 3/8	2 3/8	15/16	1 5/16	8 1/4	3 3/8	2 1/32	9/32	7/8	44.2
3 15/16 4	EMP-63 EMP-64	AR-3-315 AR-3-4	5	17	11 3/4	14 3/4	4 3/4	2 1/2	1 1/8	15/16	10	4 5/8	2 11/16	9/32	1	72.0

For Load Ratings, see page 62.

For Medium Duty Bearing Inserts-Single Lock, see page 60.



**Single Lip Contact Seal**  
Available on all sizes. Recommended where moisture conditions prevail. To specify, add suffix "C" (EMP-32C).



**Felt Seal Standard**  
Positive sealing for low, medium, and high speed operation.

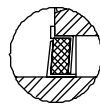

**Hi-Temp Seal**  
Available as an option where operating temperatures are in 250-400° range. (See seal options page 188).

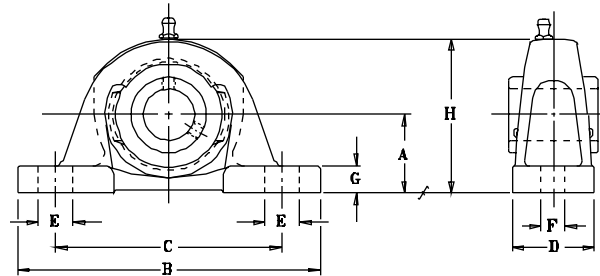
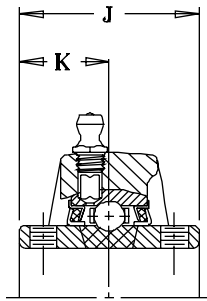

## MPD Series Medium Duty Pillow Blocks...Setscrew Locking – Double Lock

SHAFT DIAM. IN MM	PART NO.	BRG. NO.	Dimensions In Inches											BOLT SIZE IN.	UNIT WT.
			A	B	C		D	E	F	G	H	J	K		
					MIN.	MAX.									
15/16 1	MPD-15 MPD-16	3-015D 3-1D	1 3/4	6 1/4	4 3/16	5 3/16	2	1	9/16	5/8	3 7/16	1 3/4	7/8	1/2	4.0
1 3/16 1 1/4	MPD-19 MPD-20	3-13D 2-14D	1 7/8	6 7/8	4 1/2	5 1/2	2 1/4	1	9/16	11/16	3 13/16	2	1	1/2	5.4
1 7/16	MPD-23	3-17D	2 1/8	8	5	6 3/8	2 1/4	1 3/16	9/16	3/4	4 3/16	2 5/16	1 5/32	1/2	6.8
1 1/2	MPD-24	3-18D	2 5/16	8 3/4	5 1/2	6 3/4	2 5/8	1 1/4	11/16	13/16	4 9/16	2 3/8	1 3/16	5/8	9.0
1 11/16 1 3/4	MPD-27 MPD-28	3-111D 3-112D	2 5/16	8 3/4	5 7/16	6 13/16	2 5/8	1 5/16	11/16	13/16	4 5/8	2 1/2	1 1/4	5/8	9.5
1 15/16 2	MPD-31 MPD-32	3-115D 2-2D	2 1/2	9 1/2	5 15/16	7 9/16	2 7/8	1 7/16	11/16	7/8	5 3/32	2 5/8	1 5/16	5/8	11.7
2 3/16 2 1/4	MPD-35 MPD-36	3-23D 2-24D	2 3/4	10 1/4	6 9/16	7 15/16	3 1/8	1 7/16	13/16	1 1/16	5 5/8	3 1/8	1 9/16	3/4	16.2
2 7/16 2 1/2	MPD-39 MPD-40	3-27D 3-28D	3	11 1/4	7 1/8	8 7/8	3 1/4	1 5/8	13/16	1 1/16	6 1/4	3 1/2	1 3/4	3/4	21.5
2 11/16	MPD-43	3-211D	3 1/2	13	7 7/8	10 1/8	3 1/2	2	15/16	1 1/8	7	3 1/2	1 3/4	7/8	29.2
2 15/16 3	MPD-47 MPD-48	3-215D 3-3D	3 1/2	13	7 7/8	10 1/8	3 1/2	2	15/16	1 1/4	7 1/4	3 7/8	1 15/16	7/8	31.5
3 3/16 3 1/4	MPD-51 MPD-52	3-33D 2-34D	4	15	9 11/16	12 9/16	4	2 5/16	15/16	1 1/4	8	4 1/16	2 1/32	7/8	44.1
3 7/16 3 1/2	MPD-55 MPD-56	3-37D 2-38D	4	15	9 5/8	12 5/8	4 3/8	2 3/8	15/16	1 5/16	8 1/4	4 7/16	2 7/32	7/8	47.8
3 15/16 4	MPD-63 MPD-64	3-315D 3-4D	5	17	11 3/4	14 3/4	4 3/4	2 1/2	1 1/8	1 5/16	10	5 3/8	2 11/16	1	73.2

For Load Ratings, see page 62.

For Medium Duty Bearing Inserts-Double Lock, see page 61.

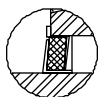

**Felt Seal Standard**  
Positive sealing for low, medium, and high speed operation.



**Single Lip Contact Seal**  
Available on all sizes. Recommended where moisture conditions prevail. To specify, add suffix "C" (MPD-32C).

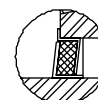

**Hi-Temp Seal**  
Available as an option where operating temperatures are in 250-400° range. (See seal options on page 188).





MOUNTED BALL BEARINGS

**SEALMASTER®**

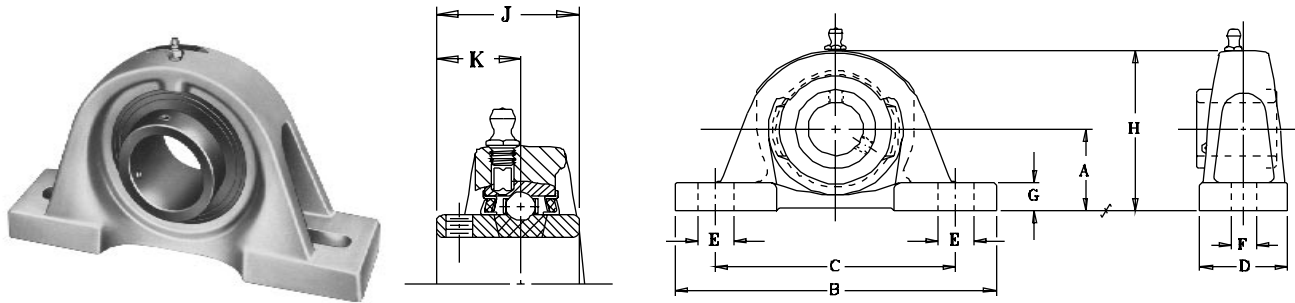

## SPM Series Medium Duty Pillow Blocks...Setscrew Locking

SHAFT DIAM.	PART NO.	BRG. NO.	Dimensions in Inches											BOLT SIZE IN.	UNIT WT.
			A	B	C		D	E	F	G	H	J	K		
					MIN.	MAX.									
1 3/16	SPM-19	3-13	2	7 1/2	5 3/8	6 1/8	2	7/8	9/16	5/8	3 7/8	1 11/16	1	1/2	6.9
1 7/16	SPM-23	3-17	2 3/8	8 1/4	5 5/8	6 7/8	2 1/4	1 1/4	3/4	3/4	4 1/2	1 15/16	1 3/16	5/8	7.1
1 11/16	SPM-27	3-111	2 3/8	8 3/4	5 7/8	7 1/8	2 3/8	1 1/4	3/4	3/4	4 5/8	2 1/32	1 9/32	5/8	9.7
1 3/4	SPM-28	3-112													
1 15/16	SPM-31	3-115	2 3/4	10 1/2	6 3/4	8 1/2	2 1/2	1 1/2	3/4	7/8	5 5/16	2 3/16	1 5/16	5/8	11.9
2 3/16	SPM-35	3-23	3 1/8	11 1/4	7 5/8	9 3/8	2 3/4	1 1/2	3/4	7/8	5 15/16	2 9/16	1 9/16	5/8	16.6
2 7/16	SPM-39	3-27	3 1/8	11 1/2	7 7/8	9 3/8	3	1 1/2	7/8	7/8	6 1/4	2 3/4	1 11/16	3/4	20.1
2 1/2	SPM-40	3-28													

For Load Ratings, see page 62.

For Medium Duty Bearing Inserts-Single Lock, see page 60.



**Single Lip Contact Seal**  
Available on all sizes. Recommended where moisture conditions prevail. To specify, add suffix "C" (SPM-31C).



**Felt Seal Standard**  
Positive sealing for low, medium, and high speed operation.

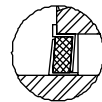

**Hi-Temp Seal**  
Available as an option where operating temperatures are in 250-400° range. (See seal options on page 188).

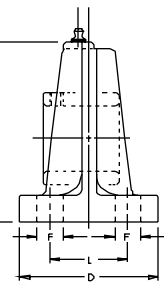
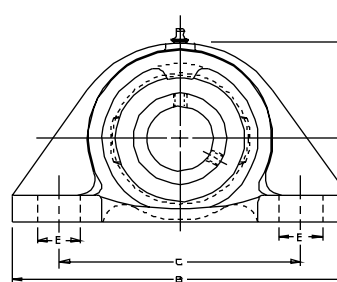
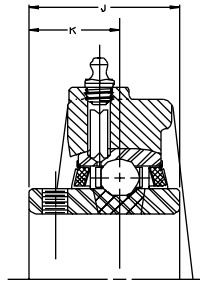

## MFP Series Medium Duty Four-Bolt Base Pillow Blocks...Setscrew Locking

SHAFT DIAM.	PART NO.	BRG. NO.	Dimensions In Inches												BOLT SIZE IN.	UNIT WT.
			A	B	C		D	E	F	G	H	J	K	L		
IN	MM				MIN.	MAX.										
1 15/16 2	MFP-31 MFP-32 MFP-310	3-115 2-2 5310	2 1/2	9 3/4	6 3/8	7 5/8	4	1 1/4	3/4	13/16	5 3/8	2 3/16	1 5/16	2 1/4	5/8	13.7
2 3/16 2 1/4	MFP-35 MFP-36 MFP-311	3-23 2-24 5311	2 3/4	10 1/4	6 7/8	8 1/8	4 1/8	1 1/4	3/4	7/8	5 13/16	2 9/16	1 9/16	2 1/4	5/8	17.0
2 7/16 2 1/2	MFP-39 MFP-40 MFP-313	3-27 3-28 5313	3	11 1/4	7 1/2	9	4 1/2	1 3/8	3/4	1	6 1/2	2 3/4	1 11/16	2 5/8	5/8	23.3
2 11/16 70	MFP-43 MFP-314	3-211 5314	3 1/2	13	9	10 1/2	5	1 1/2	7/8	1 1/8	7 1/4	3 1/16	1 3/4	2 3/4	3/4	34.0
2 15/16 3	MFP-47 MFP-48 MFP-315	3-215 3-3 5315	3 1/2	13	9	10 1/2	5	1 1/2	7/8	1	7 3/8	3 1/4	1 15/16	2 3/4	3/4	36.5
3 3/16 3 1/4	MFP-51 MFP-52 MFP-316	3-33 2-34 5316	4	15	10 3/4	12 1/4	5	1 1/2	7/8	1 1/16	8 7/16	3 3/8	2 1/32	3	3/4	44.5
3 7/16 3 1/2	MFP-55 MFP-56	3-37 2-38	4	15	10 3/4	12 1/4	5	1 1/2	7/8	1 1/16	8 7/16	3 25/32	2 7/32	3	3/4	48.6
3 15/16 4	MFP-63 MFP-64 MFP-320	3-315 3-4 5320	5	17	12 7/16	14 1/16	6	1 11/16	1	1 1/4	10 1/4	4 5/8	2 11/16	3 1/2	7/8	83.5
4 7/16 4 15/16	MFPD-71 <sup>1</sup> MFPD-79 <sup>2</sup>	3-47D <sup>2</sup> 3-415D <sup>2</sup>	6	19	14	16	5 1/2	2	1 1/8	1 5/8	12 1/8	5 3/4	2 7/8	3 1/4	1	130.0

<sup>1</sup> Units MFPD-71 and MFPD-79 are equipped with four set screws: two on each end of inner race extensions.

<sup>2</sup> Units MFPD-71 and MFPD-79 are not available with contact seal.

For Load Ratings, see page 62.

For Medium Duty Bearing Inserts-Single Lock, see page 60.

For Medium Duty Bearing Inserts-Double Lock, see page 61.

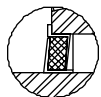

**Felt Seal Standard**  
Positive sealing for low, medium, and high speed operation.



**Single Lip Contact Seal**  
Available on all sizes. Recommended where moisture conditions prevail. To specify, add suffix "C" (MFP-32C).

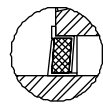

**Hi-Temp Seal**  
Available as an option where operating temperatures are in 250-400° range. (See seal options on page 188).



MOUNTED BALL BEARINGS

**SEALMASTER®**

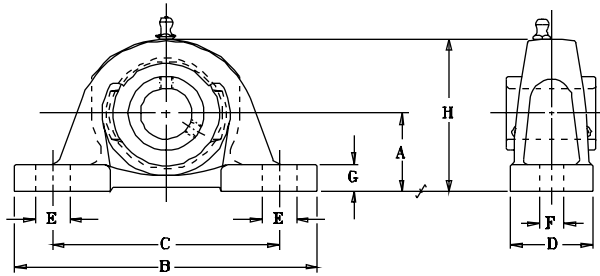
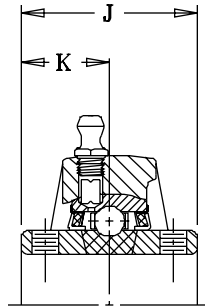

## MSPD Series Medium Duty Pillow Blocks...Setscrew Locking – Double Lock

SHAFT DIAM.	PART NO.	BRG. NO.	Dimensions In Inches												BOLT SIZE IN.	UNIT WT.
			A	B	C		D	E	F	G	H	J	K			
					MIN.	MAX.										
1 11/16 1 3/4	MSPD-27 MSPD-28	3-111D 3-112D	2 3/8	8 7/8	6 7/16	7 7/16	2 1/2	1 1/8	3/4	3/4	4 13/16	2 1/2	1 1/4	5/8	9.5	
1 15/16 2	MSPD-31 MSPD-32	3-115D 2-2D	2 3/4	10	7 1/8	8 3/8	2 5/8	1 1/4	3/4	7/8	5 7/16	2 5/8	1 5/16	5/8	12.5	
2 3/16 2 1/4	MSPD-35 MSPD-36	3-23D 2-24D	3 1/8	10 7/8	7 7/8	9 3/8	2 3/4	1 3/8	3/4	15/16	6 1/16	3 1/8	1 9/16	5/8	17.0	
2 7/16 2 1/2	MSPD-39 MSPD-40	3-27D 3-28D	3 1/8	11 3/4	8 3/4	9 7/8	3	1 5/16	7/8	1	6 5/16	3 1/2	1 3/4	3/4	22.0	
2 11/16	MSPD-43	3-211D	3 3/4	13 3/8	10 1/8	11 3/8	3 1/4	1 3/8	7/8	1	7 5/16	3 1/2	1 3/4	3/4	28.0	
2 15/16 3	MSPD-47 MSPD-48	3-215D 3-3D	3 3/4	13 3/4	10	11 1/2	3 3/8	1 5/8	1	1 3/16	7 1/2	3 7/8	1 15/16	7/8	33.0	
3 7/16 3 1/2	MSPD-55 MSPD-56	3-37D 2-38D	4 9/16	15 3/8	12 1/8	13 1/2	4	1 9/16	1	1 1/4	8 13/16	4 7/16	2 7/32	7/8	51.0	
3 15/16 4	MSPD-63 MSPD-64	3-315D 3-4D	5 1/8	17	13 1/8	14 3/4	4 3/4	1 13/16	1 1/8	1 1/4	10 1/8	5 3/8	2 11/16	1	74.5	
4 7/16 4 15/16	MSPD-71 MSPD-79	3-47D <sup>1</sup> 3-415D <sup>1</sup>	6 1/4	21 1/4	15 1/16	18 3/16	6 1/4	2 11/16	1 1/4	1 3/4	12 1/2	5 3/4	2 7/8	1 1/8	159.0	

<sup>1</sup> Units MSPD-71 and MSPD-79 are not available with contact seal.

For Load Ratings, see page 62.

For Medium Duty Bearing Inserts-Double Lock, see page 61.



**Felt Seal Standard**  
Positive sealing for low, medium, and high speed operation.



**Single Lip Contact Seal**  
Available on all sizes. Recommended where moisture conditions prevail. To specify, add suffix "C" (MSPD-32C).

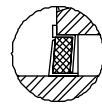

**Hi-Temp Seal**  
Available as an option where operating temperatures are in 250-400° range. (See seal options on page 188).

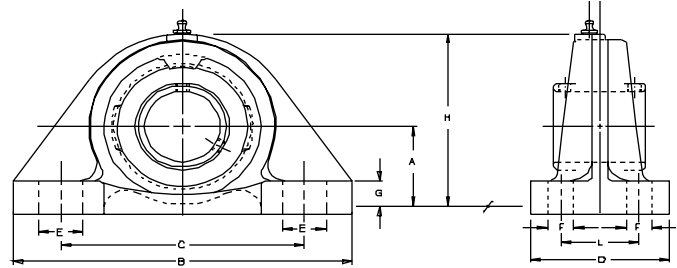
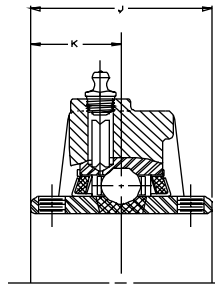

## MSFPD Series Medium Duty Four-Bolt Base Pillow Blocks...Setscrew Locking

SHAFT DIAM.	PART NO.	BRG. NO.	Dimensions In Inches													BOLT SIZE IN.	UNIT WT.
			A	B	C		D	E	F	G	H	J	K	L			
IN	MM				MIN.	MAX.											
1 15/16 2	MSFPD-31 MSFPD-32	3-115D 2-2D	2 3/4	9 3/4	6 3/8	7 5/8	4	1 1/4	3/4	1 1/16	5 5/8	2 5/8	1 5/16	2 1/4	5/8	15.4	
2 3/16 2 1/4	MSFPD-35 MSFPD-36	3-23D 2-24D	3 1/8	10 1/4	6 7/8	8 1/8	4 1/8	1 1/4	3/4	1 1/4	6 3/16	3 1/8	1 9/16	2 1/4	5/8	20.1	
2 7/16 2 1/2	MSFPD-39 MSFPD-40	3-27D 3-28D	3 1/8	11 1/4	7 1/2	9	4 1/2	1 3/8	3/4	1 1/8	6 5/8	3 1/2	1 3/4	2 5/8	5/8	25.4	
2 11/16	MSFPD-43	3-211D	3 3/4	13	9	10 1/2	5	1 1/2	7/8	1 3/8	7 1/2	3 1/2	1 3/4	2 3/4	3/4	37.3	
2 15/16 3	MSFPD-47 MSFPD-48	3-215D 3-3D	3 3/4	13	9	10 1/2	5	1 1/2	7/8	1 1/4	7 5/8	3 7/8	1 15/16	2 3/4	3/4	40.1	
3 3/16 3 1/4	MSFPD-51 MSFPD-52	3-33D 2-34D	4 1/8	15	10 3/4	12 1/4	5	1 1/2	7/8	1 3/16	8 9/16	4 1/16	2 1/32	3	3/4	51.2	
3 7/16 3 1/2	MSFPD-55 MSFPD-56	3-37D 2-38D	4 9/16	15	10 3/4	12 1/4	5	1 1/2	7/8	1 1/4	9	4 7/16	2 7/32	3	3/4	51.8	
3 15/16 4	MSFPD-63 MSFPD-64	3-315D 3-4D	5 1/8	17	12 7/16	14 1/16	6	1 11/16	1	1 3/8	10 3/8	5 3/8	2 11/16	3 1/2	7/8	84.6	
4 7/16 4 15/16	MSFPD-71 MSFPD-79	3-47D <sup>1</sup> 3-415D <sup>1</sup>	6 1/4	19	14	16	5 1/2	2	1 1/8	1 7/8	12 3/8	5 3/4	2 7/8	3 1/4	1	136.0	

For Load Ratings, see page 62.

For Medium Duty Bearing Inserts-Double Lock, see page 61.

<sup>1</sup> Units MSFPD-71 and MSFPD-79 are not available with contact seal.

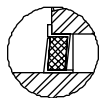

**Felt Seal Standard**  
Positive sealing for low, medium, and high speed operation.



**Single Lip Contact Seal**  
Available on all sizes. Recommended where moisture conditions prevail. To specify, add suffix "C" (MSFPD-32C).

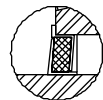

**Hi-Temp Seal**  
Available as an option where operating temperatures are in 250-400° range. (See seal options on page 188).



MOUNTED BALL BEARINGS

**SEALMASTER®**

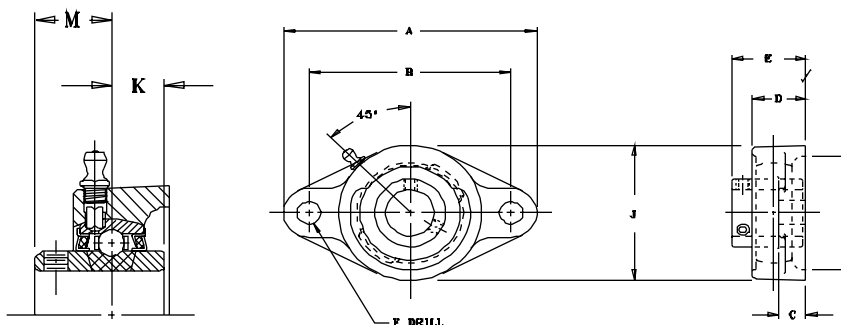

## MSFT Series Medium Duty Two-Bolt Flange Units...Setscrew Locking

SHAFT DIAM.	PART NO.	BRG. NO.	Dimensions in Inches										UNIT WT.
			A	B	C	D	E	F	H CORED	J	K	M	
15/16 1	MSFT-15 MSFT-16 MSFT-305	3-015 3-1 5305	5 9/16	4 19/32	17/32	1 11/64	1 9/16	15/32	2 7/8	3 1/4	5/8	7/8	2.4
1 3/16 1 1/4	MSFT-19 MSFT-20 MSFT-306	3-13 2-14 5306	6 1/8	5 1/8	9/16	1 11/32	1 3/4	17/32	3 5/16	3 3/4	11/16	1	3.4
1 7/16 35	MSFT-23 MSFT-307	3-17 5307	6 3/4	5 21/32	9/16	1 1/2	2 1/64	17/32	3 1/2	4 1/8	3/4	1 3/16	4.6
1 1/2 40	MSFT-24 MSFT-308	3-18 5308	7 1/16	5 27/32	9/16	1 9/16	2 3/64	19/32	3 7/8	4 3/8	3/4	1 3/16	5.2
1 11/16 1 3/4	MSFT-27 MSFT-28 MSFT-309	3-111 3-112 5309	7 7/16	6 3/16	9/16	1 9/16	2 5/32	19/32	4	4 9/16	3/4	1 9/32	5.6
15/16 2	MSFT-31 MSFT-32 MSFT-310	3-115 2-2 5310	8 1/2	7 1/4	13/16	1 3/4	2 5/16	21/32	4 1/4	5 1/4	7/8	1 5/16	8.6

For Load Ratings, see page 62.

For Medium Duty Bearing Inserts-Single Lock, see page 60.

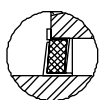

**Felt Seal Standard**  
Positive sealing for low, medium, and high speed operation.



**Single Lip Contact Seal**  
Available on all sizes. Recommended where moisture conditions prevail. To specify, add suffix "C" (MSFT-32C).

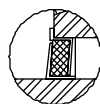

**Hi-Temp Seal**  
Available as an option where operating temperatures are in 250-400° range. (See seal options on page 188).

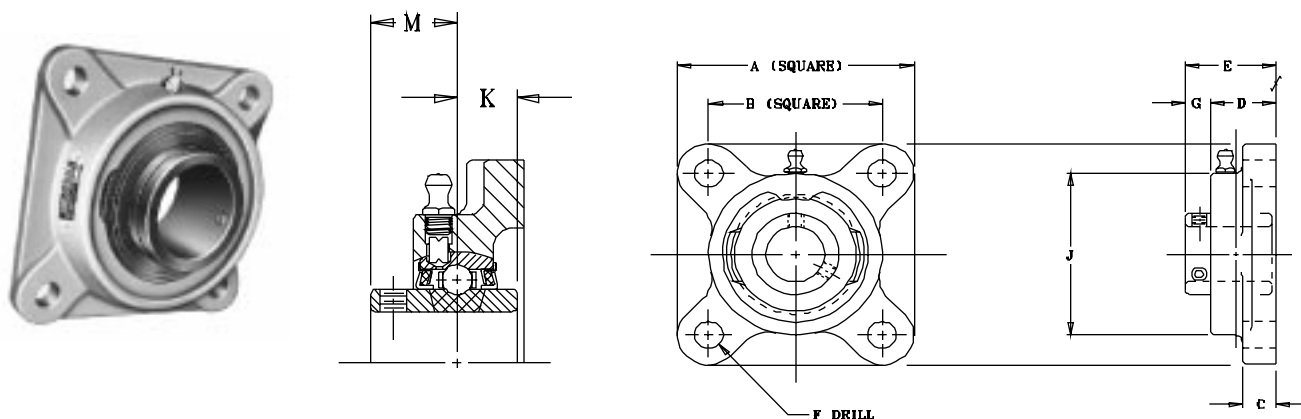

## MSF Series Medium Duty Four-Bolt Flange Units...Setscrew Locking

SHAFT DIAM.	PART NO.	BRG. NO.	Dimensions in Inches										UNIT Wt.
			A	B	C	D	E	F	G	J	K	M	
15/16 1	MSF-15 MSF-16 MSF-305	3-015 3-1 5305	4 1/4	3 1/4	17/32	1 11/64	1 9/16	15/32	25/64	3 7/32	5/8	7/8	3.6
1 3/16 1 1/4 25	MSF-19 MSF-20 MSF-306	3-13 2-14 5306	4 5/8	3 5/8	9/16	1 11/32	1 3/4	17/32	13/32	3 23/32	11/16	1	4.1
1 7/16 35	MSF-23 MSF-307	3-17 5307	5 1/8	4	9/16	1 1/2	2 1/64	17/32	33/64	4 5/64	3/4	1 3/16	5.5
1 1/2 40	MSF-24 MSF-308	3-18 5308	5 3/8	4 1/8	9/16	1 9/16	2 3/64	19/32	31/64	4 21/64	3/4	1 3/16	6.0
1 11/16 1 3/4 45	MSF-27 MSF-28 MSF-309	3-111 3-112 5309	5 5/8	4 3/8	9/16	1 9/16	2 5/32	19/32	19/32	4 9/16	3/4	1-9/32	6.8
1 15/16 2 50	MSF-31 MSF-32 MSF-310	3-115 2-2 5310	6 3/8	5 1/8	13/16	1 3/4	2 5/16	21/32	9/16	5 1/4	7/8	1 5/16	10.5
2 3/16 2 1/4 55	MSF-35 MSF-36 MSF-311	3-23 2-24 5311	6 7/8	5 5/8	13/16	1 15/16	2 11/16	21/32	3/4	5 7/16	1	1 9/16	12.1
2 7/16 2 1/2 65	MSF-39 MSF-40 MSF-313	3-27 3-28 5313	7 3/8	5 7/8	11/16	2 5/16	3	21/32	11/16	6 1/8	1 1/16	1 11/16	16.4
2 11/16 70	MSF-43 MSF-314	3-211 5314	7 3/4	6	1	2 3/8	3 3/16	25/32	13/16	6 1/2	1 5/16	1 3/4	20.6
2 15/16 3 75	MSF-47 MSF-48 MSF-315	3-215 3-3 5315	7 3/4	6	7/8	2 11/16	3 1/2	25/32	13/16	6 3/4	1 5/16	1 15/16	21.4
3 3/16 3 1/4 80	MSF-51 MSF-52 MSF-316	3-33 2-34 5316	8 7/16	6 3/4	1	2 3/4	3 17/32	25/32	25/32	7 1/4	1 11/32	2 1/32	26.7
3 7/16 3 1/2	MSF-55 MSF-56	3-37 2-38	8 7/16	6 3/4	1	3	3 31/32	25/32	31/32	7 3/4	1 9/16	2 7/32	30.0
3 15/16 4 100	MSF-63 MSF-64 MSF-320	3-315 3-4 5320	10 9/16	8 5/16	1 1/4	3 13/16	5	1 1/32	1 3/16	9 1/4	1 15/16	2 11/16	55.1
4 7/16 4 15/16	MSFD-71 <sup>1</sup> MSFD-79 <sup>1</sup>	3-47D 3-415D	12 3/4	10	1 9/16	4 3/4	6	1 9/32	1 1/4	11 1/2	2 7/8	2 7/8	115.0

<sup>1</sup> Units MSFD-71 and MSFD-79 are equipped with four set screws: two on each end of inner race extensions.

<sup>1</sup> Units MSFD-71 and MSFD-79 are not available with contact seal.

For Load Ratings, see page 62.

For Medium Duty Bearing Inserts-Single Lock, see page 60.

For Medium Duty Bearing Inserts-Double Lock, see page 61.

See page 54 for seal arrangements.



MOUNTED BALL BEARINGS

**SEALMASTER®**

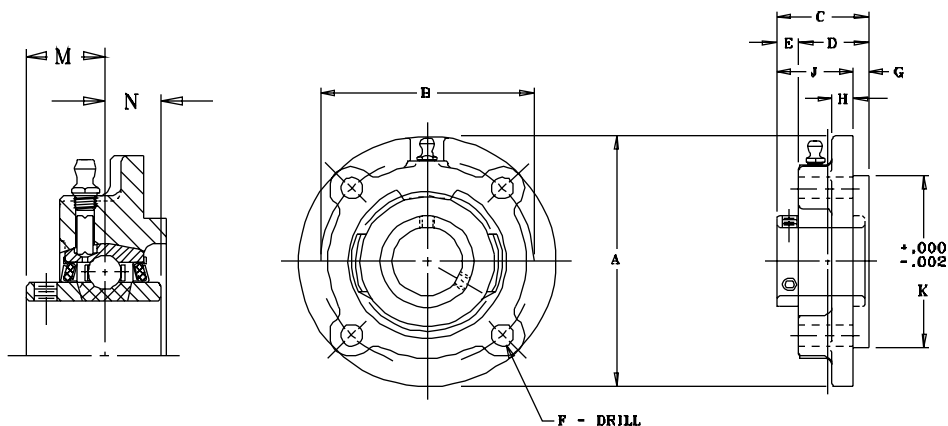

## MFC Series Medium Duty Flange Cartridge Units...Setscrew Locking

SHAFT DIAM. IN MM	PART NO.	BRG. NO.	Dimensions In Inches												UNIT WT.
			A	B	C	D	E	F	G	H	J	K	M	N	
1 15/16 1 25	MFC-15 MFC-16 MFC-305	3-015 3-1 5305	4 3/8	3 5/8	1 9/16	1 3/16	3/8	3/8	1/4	3/8	1 5/16	3.000	7/8	5/8	3.0
1 13/16 1 1/4 30	MFC-19 MFC-20 MFC-306	3-13 2-14 5306	5	4 1/8	1 11/16	1 1/4	7/16	7/16	3/8	3/8	1 5/16	3.375	1	11/16	3.9
1 7/16 1 1/2 35	MFC-23 MFC-24 MFC-307	3-17 2-18 5307	5 1/4	4 3/8	1 15/16	1 15/32	15/32	7/16	7/16	7/16	1 1/2	3.625	1 3/16	3/4	4.7
1 1/2 40	MFC-24H MFC-308	3-18 5308	6 1/8	5 1/8	1 15/16	1 7/16	1/2	1/2	7/16	7/16	1 1/2	4.250	1 3/16	3/4	6.0
1 11/16 1 3/4 45	MFC-27 MFC-28 MFC-309	3-111 3-112 5309	6 1/8	5 1/8	2 1/32	1 15/32	9/16	1/2	15/32	7/16	1 9/16	4.250	1 9/32	3/4	6.5
1 15/16 2 50	MFC-31 MFC-32 MFC-310	3-115 2-2 5310	6 3/8	5 3/8	2 3/16	1 5/8	9/16	1/2	5/8	7/16	1 9/16	4.500	1 5/16	7/8	7.5
2 3/16 2 1/4 55	MFC-35 MFC-36 MFC-311	3-23 2-24 5311	7 1/8	6	2 9/16	1 7/8	11/16	9/16	7/8	1/2	1 11/16	5.000	1 9/16	1	10.5
2 7/16 2 1/2 65	MFC-39 MFC-40 MFC-313	3-27 3-28 5313	7 5/8	6 1/2	2 7/8	2 3/16	11/16	9/16	1 1/8	9/16	1 3/4	5.500	1 11/16	1 1/16	14.0
2 11/16 70	MFC-43 MFC-314	3-211 5314	8 3/4	7 1/2	3 1/16	2 5/16	3/4	11/16	1 1/16	9/16	2	6.375	1 3/4	1 5/16	18.7
2 15/16 3 75	MFC-47 MFC-48 MFC-315	3-215 3-3 5315	8 3/4	7 1/2	3 1/4	2 7/16	13/16	11/16	1 1/4	5/8	2	6.375	1 15/16	1 5/16	20.0
3 7/16 3 1/2	MFC-55 MFC-56	3-37 2-38	10 1/4	8 5/8	3 25/32	2 3/4	1 1/32	13/16	1 1/8	3/4	2 21/32	7.375	2-7/32	1 9/16	32.0
3 15/16 4 100	MFC-63 MFC-64 MFC-320	3-315 3-4 5320	10 7/8	9 3/8	4 5/8	3 1/4	1 3/8	13/16	1 1/8	7/8	3 1/2	*8.125	2 11/16	1 15/16	44.0

For Load Ratings, see page 62.

For Medium Duty Bearing Inserts-Single Lock, see page 60.

\* +.000" -.004"

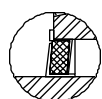

**Felt Seal Standard**  
Positive sealing for low, medium, and high speed operation.



**Single Lip Contact Seal**  
Available on all sizes. Recommended where moisture conditions prevail. To specify, add suffix "C" (MFC-32C).

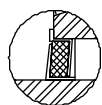

**Hi-Temp Seal**  
Available as an option where operating temperatures are in 250-400° range. (See seal options on page 188).

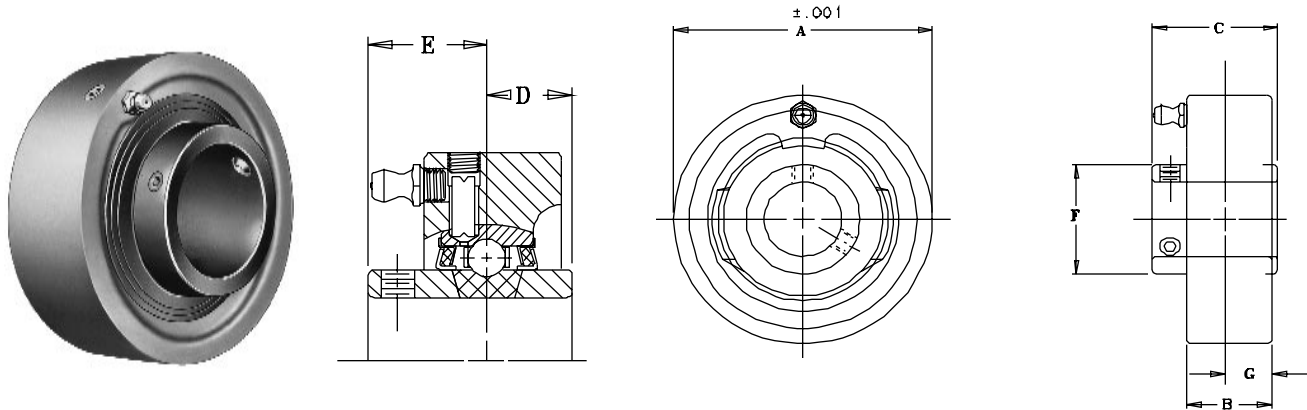

## MSC Series Medium Duty Cartridge Units...Setscrew Locking

SHAFT DIAM.	PART NO.	BRG. NO.	Dimensions In Inches							UNIT WT.
			A	B	C	D	E	F	G	
15/16 1	MSC-15 MSC-16 MSC-305	3-015 3-1 5305	3 1/2	1 3/32	1 1/2	5/8	7/8	1 19/32	9/16	2.5
1 3/16 1 1/4 30	MSC-19 MSC-20 MSC-306	3-13 2-14 5306	3 7/8	1 7/32	1 11/16	11/16	1	1 55/64	5/8	3.2
1 7/16 35	MSC-23 MSC-307	3-17 5307	4 3/16	1 15/32	1 15/16	3/4	1 3/16	2 1/16	3/4	4.1
1 1/2 40	MSC-24 MSC-308	3-18 5308	4 3/8	1 7/16	1 15/16	3/4	1 3/16	2 19/64	23/32	4.5
1 11/16 1 3/4 45	MSC-27 MSC-28 MSC-309	3-111 3-112 5309	4 9/16	1 15/32	2 1/32	3/4	1-9/32	2 15/32	3/4	4.9
1 15/16 2 50	MSC-31 MSC-32 MSC-310	3-115 2-2 5310	4 15/16	1 19/32	2 3/16	7/8	1 5/16	2 23/32	27/32	5.8
2 3/16 2 1/4 55	MSC-35 MSC-36 MSC-311	3-23 2-24 5311	5 7/8	1 5/8	2 9/16	1	1 9/16	2 63/64	13/16	9.5
2 7/16 2 1/2 65	MSC-39 MSC-40 MSC-313	3-27 3-28 5313	6 1/4	2	2 3/4	1 1/16	1 11/16	3 7/16	1	12.6
2 11/16 70	MSC-43 MSC-314	3-211 5314	6 5/8	2	3 1/16	1 5/16	1 3/4	3 41/64	1	14.1
2 15/16 3 75	MSC-47 MSC-48 MSC-315	3-215 3-3 5315	7	2 3/16	3 1/4	1 5/16	1 15/16	3 59/64	1 3/32	16.6
3 3/16 3 1/4 80	MSC-51 MSC-52 MSC-316	3-33 2-34 5316	7 7/16	2 1/2	3 3/8	1 11/32	2 1/32	4 5/32	1 1/4	20.2
3 7/16 3 1/2	MSC-55 MSC-56	3-37 2-38	8 3/16	2 1/2	3 25/32	1 9/16	2 7/32	4 25/64	1 1/4	25.8
3 15/16 4 100	MSC-63 MSC-64 MSC-320	3-315 3-4 5320	9 1/2	3	4 5/8	1 15/16	2 11/16	5 11/64	1 1/2	42.0

For Load Ratings, see page 62.

For Medium Duty Bearing Inserts-Single Lock, see page 60.

See page 56 for seal arrangements.



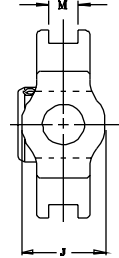
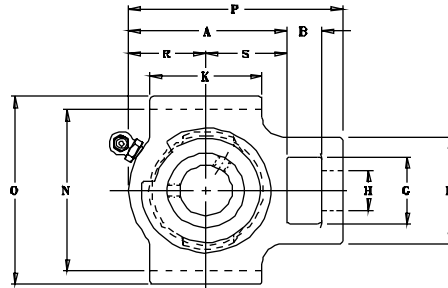
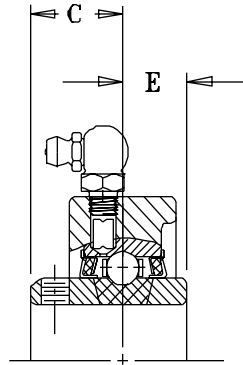

## MST Series Medium Duty Take-Up Units...Setscrew Locking

SHAFT DIAM. IN MM	PART NO.	BRG. NO.	Dimensions In Inches															UNIT WT.
			A	B	C	E	F	G	H Core	J Hub	K	M	N	O	P	R	S	
15/16 1 25	MST-15 MST-16 MST-305	3-015 3-1 5305	3 7/16	5/8	7/8	5/8	2 3/16	1 7/16	7/8	1 3/4	2 1/4	17/32	3 1/2	4	4 7/16	1 11/16	1 3/4	3.4
1 3/16 1 1/4 30	MST-19 MST-20 MST-306	3-13 2-14 5306	3 15/16	5/8	1	11/16	2 1/2	1 7/16	7/8	1 3/4	2 1/2	17/32	3 1/2	4	5 1/16	2	1 15/16	4.0
1 7/16 35	MST-23 MST-307	3-17 5307	4 5/16	3/4	1 3/16	3/4	3 1/4	1 15/16	1 1/8	2 1/8	3 1/4	11/16	4	4 1/2	5 11/16	2 3/16	2 1/8	6.2
1 1/2 40	MST-24 MST-308	3-18 5308	4 5/16	3/4	1 3/16	3/4	3 1/4	1 15/16	1 1/8	2 3/16	3 1/4	11/16	4	4 5/8	5 11/16	2 1/4	2 1/16	6.2
1 11/16 1 3/4 45	MST-27 MST-28 MST-309	3-111 3-112 5309	4 1/2	3/4	1 9/32	3/4	3 1/4	1 15/16	1 1/8	2 3/16	3 3/8	11/16	4	4 5/8	5 7/8	2 5/16	2 3/16	6.4
1 15/16 2 50	MST-31 MST-32 MST-310	3-115 2-2 5310	5	1	1 5/16	7/8	4	2 1/2	1 3/8	2 1/4	3 3/4	1 1/16	5 1/8	5 3/4	6 3/4	2 9/16	2 7/16	10.0
2 3/16 2 1/4 55	MST-35 MST-36 MST-311	3-23 2-24 5311	5 3/8	1 1/4	1 9/16	1	4	2 1/2	1 3/8	2 3/8	4	1 1/16	5 1/8	5 3/4	7 5/8	2 15/16	2 11/16	12.3
2 7/16 2 1/2 65	MST-39 MST-40 MST-313	3-27 3-28 5313	6 3/4	1 1/4	1 11/16	1 1/16	4 3/8	2 3/4	1 5/8	3 3/8	4 3/4	1 1/16	5 15/16	6 9/16	8 13/16	3 7/16	3 5/16	19.5
2 11/16 70	MST-43 MST-314	3-211 5314	7 1/16	1 1/4	1 3/4	1 5/16	4 3/8	2 3/4	1 5/8	3 3/8	4 3/4	1 1/16	5 15/16	6 9/16	9 1/8	3 5/8	3 7/16	19.8
2 15/16 3 75	MST-47 MST-48 MST-315	3-215 3-3 5315	7 3/16	1 1/4	1 15/16	1 5/16	4 3/8	2 3/4	1 5/8	3 3/8	4 3/4	1 1/16	6 1/2	7 1/4	9 1/4	3 3/4	3 7/16	23.0
3 3/16 3 1/4 80	MST-51 MST-52 MST-316	3-33 2-34 5316	7 5/8	1 1/2	2 1/32	1 11/32	4 7/8	2 7/8	1 7/8	3 1/2	6 3/16	1 13/16	6 13/16	7 13/16	10 1/4	3 7/8	3 3/4	31.8
3 15/16 4 100	MST-63 MST-64 MST-320	3-315 3-4 5320	9 1/4	1 1/2	2 11/16	1 15/16	4 7/8	2 7/8	1 7/8	3 1/2	6 1/2	1 13/16	8 3/8	9 3/8	11 7/8	4 3/4	4 1/2	50.0

For Load Ratings, see page 62.

For Medium Duty Bearing Inserts-Single Lock, see page 60.



**Single Lip Contact Seal**  
Available on all sizes. Recommended where moisture conditions prevail. To specify, add suffix "C" (MST-32C).

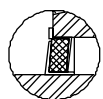

**Felt Seal Standard**  
Positive sealing for low, medium, and high speed operation.

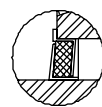

**Hi-Temp Seal**  
Available as an option where operating temperatures are in 250-400° range. (See seal options on page 188).

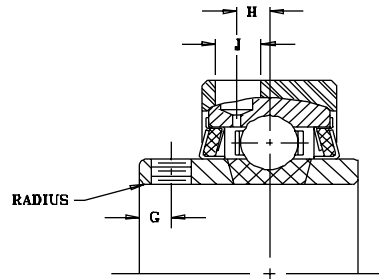
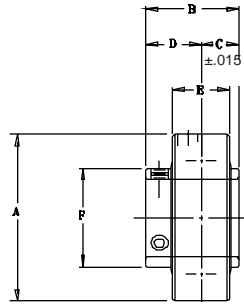

## AR Series Medium Duty Expansion Units...Setscrew Locking

SHAFT DIAM.		BRG. NO.	Dimensions in Inches										SET SCREW TAP	UNIT WT.
			*A	B	C	D	E	F	G	H	J	RADIUS		
15/16 1	25	AR-3-015 AR-3-1 AR-305	2.687	1 1/2	5/8	7/8	61/64	1 19/32	7/32	7/32	1/4	.040	1/4-28	1.5
1 3/16 30		AR-3-13 AR-306	3.140	1 11/16	11/16	1	1 1/64	1 55/64	1/4	1/4	1/4	.040	5/16-24	2.1
1 7/16 35		AR-3-17 AR-307	3.375	1 15/16	3/4	1 3/16	1 11/64	2 1/16	5/16	19/64	1/4	.062	5/16-24	2.8
1 1/2 40		AR-3-18 AR-308	3.562	1 15/16	3/4	1 3/16	1 11/64	2 19/64	5/16	19/64	1/4	.062	5/16-24	3.0
1 11/16 1 3/4 45		AR-3-111 AR-3-112 AR-309	3.875	2 1/32	3/4	1 9/32	1 13/64	2 15/32	3/8	17/64	11/32	.062	3/8-24	3.5
1 15/16 50		AR-3-115 AR-310	4.250	2 3/16	7/8	1 5/16	1 17/64	2 23/32	3/8	19/64	11/32	.080	3/8-24	4.4
2 3/16 55		AR-3-23 AR-311	4.718	2 9/16	1	1 9/16	1 21/64	2 63/64	7/16	21/64	11/32	.080	3/8-24	5.8
2 7/16 2 1/2 65		AR-3-27 AR-3-28 AR-313	5.170	2 3/4	1 1/16	1 3/4	1 29/64	3 7/16	15/32	3/8	11/32	.080	7/16-20	9.3
2 11/16 70		AR-3-211 AR-314	5.375	3 1/16	1 5/16	1 3/4	1 37/64	3 41/64	7/16	3/8	11/32	.080	7/16-20	9.6
2 15/16 3 75		AR-3-215 AR-3-3 AR-315	5.875	3 1/4	1 5/16	1 15/16	1 53/64	3 59/64	17/32	13/32	15/32	.120	7/16-20	12.2
3 3/16 80		AR-3-33 AR-316	6.280	3 3/8	1 11/32	2 1/32	2 5/64	4 5/32	15/32	17/32	15/32	.120	7/16-20	15.2
3 7/16		AR-3-37	6.750	3 25/32	1 9/16	2 7/32	2 9/64	4 25/64	5/8	15/32	15/32	.120	1/2-20	18.5
3 15/16 4 100		AR-3-315 AR-3-4 AR-320	8.063	4 5/8	1 15/16	2 11/16	2 33/64	5 11/64	3/4	19/32	15/32	.120	5/8-18	32.9

For Load Ratings, see page 62.

\* Tolerance +.000" -.005"

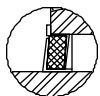

**Felt Seal Standard**  
Positive sealing for low, medium, and high speed operation.



**Single Lip Contact Seal**  
Available on all sizes. Recommended where moisture conditions prevail. To specify, add suffix "C" (AR-3-23C).

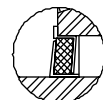

**Hi-Temp Seal**  
Available as an option where operating temperatures are in 250-400° range. (See seal options on page 188).



# MOUNTED BALL BEARINGS SEALMASTER®

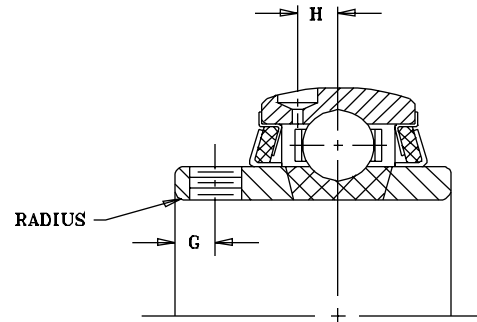
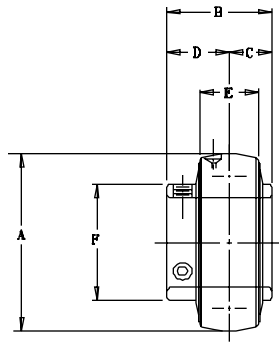

## Medium Duty Bearing Inserts...Setscrew Locking – Single Lock

SHAFT DIAM.	BRG. NO.	Dimensions in Inches									SET SCREW TAP	UNIT WT.
		A	B	C	D	E	F	G	H	RADIUS		
15/16 1	3-015 3-1 5305	62MM 2.4409	1 1/2	5/8	7/8	7/8	1 19/32	7/32	7/32	.040	1/4-28	1.0
1 3/16 30	3-13 5306	72MM 2.8346	1 11/16	11/16	1	15/16	1 55/64	1/4	1/4	.040	5/16-24	1.5
1 7/16 35	3-17 5307	80MM 3.1496	1 15/16	3/4	1 3/16	1 3/32	2 1/16	5/16	19/64	.062	5/16-24	1.9
1 1/2 40	3-18 5308	85MM 3.3465	1 15/16	3/4	1 3/16	1 3/32	2 19/64	5/16	19/64	.062	5/16-24	2.2
1 11/16 1 3/4 45	3-111 3-112 5309	90MM 3.5433	2 1/32	3/4	1 9/32	1 1/8	2 15/32	3/8	17/64	.062	3/8-24	2.4
1 15/16 50	3-115 5310	100MM 3.9370	2 3/16	7/8	1 5/16	1 3/16	2 23/32	3/8	19/64	.080	3/8-24	3.2
2 3/16 55	3-23 5311	110MM 4.3307	2 9/16	1	1 9/16	1 1/4	2 63/64	7/16	21/64	.080	3/8-24	4.2
2 7/16 2 1/2 65	3-27 3-28 5313	125MM 4.9213	2 3/4	1 1/16	1 11/16	1 3/8	3 7/16	7/16	3/8	.080	7/16-20	6.5
2 11/16 70	3-211 5314	130MM 5.1181	3 1/16	1 5/16	1 3/4	1 1/2	3 41/64	7/16	3/8	.080	7/16-20	7.1
2 15/16 3 75	3-215 3-3 5315	140MM 5.5118	3 1/4	1 5/16	1 15/16	1 11/16	3 59/64	17/32	13/32	.120	7/16-20	8.2
3 3/16 80	3-33 5316	150MM 5.9055	3 3/8	1 11/32	2 1/32	1 15/16	4 5/32	15/32	17/32	.120	7/16-20	10.0
3 7/16	3-37	160MM 6.2992	3 25/32	1 9/16	2 7/32	2	4 25/64	5/8	15/32	.120	1/2-20	11.7
3 15/16 4 100	3-315 3-4 5320	190MM 7.4803	4 5/8	1 15/16	2 11/16	2 1/2	5 11/64	3/4	19/32	.120	5/8-18	20.4

See page 59 for seal arrangements.  
For Load Ratings, see page 62.

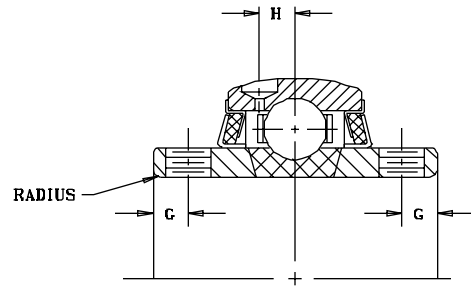
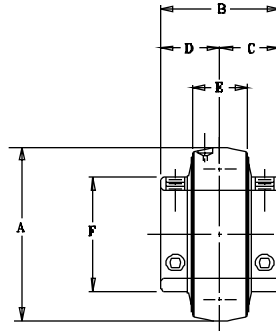

## Medium Duty Bearing Inserts... Setscrew Locking – Double Lock

SHAFT DIAM.	BRG. NO.	Dimensions in Inches									SET SCREW TAP	UNIT WT.
		A	B	C	D	E	F	G	H	RADIUS		
15/16 1	3-015D 3-1D	62MM 2.4409	1 3/4	7/8	7/8	7/8	1 19/32	7/32	7/32	.040	1/4-28	1.0
1 3/16	3-13D	72MM 2.8346	2	1	1	15/16	1 55/64	1/4	1/4	.040	5/16-24	1.5
1 7/16	3-17D	80MM 3.1496	2 5/16	1 5/32	1 5/32	1 3/32	2 1/16	5/16	19/64	.062	5/16-24	2.0
1 1/2	3-18D	85MM 3.3465	2 3/8	1 3/16	1 3/16	1 3/32	2 19/64	11/32	19/64	.062	5/16-24	2.5
1 11/16 1 3/4	3-111D 3-112D	90MM 3.5433	2 1/2	1 1/4	1 1/4	1 1/8	2 15/32	11/32	17/64	.062	3/8-24	2.7
1 15/16	3-115D	100MM 3.9370	2 5/8	1 5/16	1 5/16	1 3/16	2 23/32	5/16	19/64	.080	3/8-24	3.5
2 3/16	3-23D	110MM 4.3307	3 1/8	1 9/16	1 9/16	1 1/4	2 63/64	13/32	21/64	.080	7/16-20	4.6
2 7/16 2 1/2	3-27D 3-28D	125MM 4.9213	3 1/2	1 3/4	1 3/4	1 3/8	3 7/16	15/32	3/8	.080	7/16-20	7.1
2 11/16	3-211D	130MM 5.1181	3 1/2	1 3/4	1 3/4	1 1/2	3 41/64	7/16	3/8	.080	1/2-20	7.3
2 15/16 3	3-215D 3-3D	140MM 5.5118	3 7/8	1 15/16	1 15/16	1 11/16	3 59/64	9/16	13/32	.120	1/2-20	9.0
3 3/16	3-33D	150MM 5.9055	4 1/16	2 1/32	2 1/32	1 15/16	4 5/32	1/2	17/32	.120	1/2-20	10.8
3 7/16	3-37D	160MM 6.2992	4 7/16	2 7/32	2 7/32	2	4 25/64	1/2	15/32	.120	1/2-20	12.6
3 15/16 4	3-315D 3-4D	190MM 7.4803	5 3/8	2 11/16	2 11/16	2 1/2	5 11/64	23/32	19/32	.120	5/8-18	21.6
4 7/16 4 15/16	3-47D 3-415D	230MM 9.0551	5 3/4	2 7/8	2 7/8	2 5/8	6 11/32	5/8	11/16	.120	5/8-18	40.0

See page 59 for seal arrangements.  
For Load Ratings, see page 62.

# LOAD RATING TABLES - Medium Duty

The shaded area indicates the maximum speed ratings for double lock bearings (applicable on sizes available). All speeds listed are for the standard felt seal. See the seal selection for alternate seals.

Values in the table represent loads at ideal conditions with press fit mounting to the shaft. ABMA recommends de-rating of slip mounted bearings. To obtain de-rated load, divide load in table by 1.3. Values in the table represent equivalent radial loads only. For combined load determination, see **THE BEARING SELECTION SECTION**. Areas designated by "-" exceeds maximum value for standard bearings. Consult Sealmaster Application Engineering for load and speed applications not covered in this table.

MEDIUM DUTY		REVOLUTIONS PER MINUTE																
SHAFT SIZE	INSERT #	L10 HOURS	50	150	500	1000	1750	2000	2500	3500	4500	5000	5500	6000	6500	7500	8000	10000
15/16 1 25MM	3-015 3-1 5305	5000	1039	1039	825	654	543	519	482	431	396	383	370	360	351	334	334	-
		10000	978	978	654	519	431	412	383	342	315	304	294	286	278	265	265	-
		30000	978	678	454	360	299	286	265	237	218	211	204	198	193	184	184	-
		50000	825	572	383	304	252	241	224	200	184	178	172	167	163	155	155	-
100000	654	454	304	241	200	191	178	159	146	141	136	133	129	123	123	-	-	
30MM 1 3/16	5306 3-13	5000	1290	1290	1088	864	717	686	636	569	523	505	489	475	463	-	-	-
		10000	1290	1290	864	686	569	544	505	452	415	401	388	377	367	-	-	-
		30000	1290	895	599	475	394	377	350	313	288	278	269	262	255	-	-	-
		50000	1088	755	505	401	333	318	295	264	243	234	227	221	215	-	-	-
100000	864	599	401	318	264	253	234	210	193	186	180	175	171	-	-	-	-	
1 7/16 35MM	3-17 5307	5000	1638	1638	1381	1096	910	870	808	722	664	641	621	603	-	-	-	-
		10000	1638	1638	1096	870	722	691	641	573	527	509	493	479	-	-	-	-
		30000	1638	1136	760	603	501	479	445	397	365	353	342	332	-	-	-	-
		50000	1381	958	641	509	422	404	375	335	308	298	288	280	-	-	-	-
100000	1096	760	509	404	335	321	298	266	245	236	229	222	-	-	-	-	-	
1 1/2 45MM	3-18 5308	5000	1763	1763	1487	1180	979	937	870	777	715	690	669	-	-	-	-	-
		10000	1763	1763	1180	937	777	744	690	617	567	548	531	-	-	-	-	-
		30000	1763	1222	818	650	539	516	479	428	393	380	368	-	-	-	-	-
		50000	1487	1031	690	548	455	435	404	361	332	320	310	-	-	-	-	-
100000	1180	818	548	435	361	345	320	286	263	254	246	-	-	-	-	-	-	
1 11/16 1 3/4 45MM	3-111 3-112 5309	5000	1760	1760	1485	1178	978	935	868	776	714	689	-	-	-	-	-	-
		10000	1760	1760	1178	935	776	742	689	616	567	547	-	-	-	-	-	-
		30000	1760	1221	817	649	538	515	478	427	393	379	-	-	-	-	-	-
		50000	1485	1029	689	547	454	434	403	360	331	320	-	-	-	-	-	-
100000	1178	817	547	434	360	345	320	286	263	254	-	-	-	-	-	-	-	
1 15/16 50MM	3-115 5310	5000	2176	2176	1835	1457	1209	1156	1073	1010	959	-	-	-	-	-	-	-
		10000	2176	2176	1457	1156	959	918	852	802	762	-	-	-	-	-	-	-
		30000	2176	1509	1010	802	665	636	591	556	528	-	-	-	-	-	-	-
		50000	1835	1273	852	676	561	537	498	469	445	-	-	-	-	-	-	-
100000	1457	1010	676	537	445	426	395	372	353	-	-	-	-	-	-	-	-	
MEDIUM DUTY		REVOLUTIONS PER MINUTE																
SHAFT SIZE	INSERT #	L10 HOURS	50	150	250	500	750	1000	1250	1500	1750	2000	2500	3000	3500	4000	4500	-
55MM 2 3/16	5311 3-23	5000	2631	2631	2631	2219	1938	1761	1635	1538	1461	1398	1298	1221	1160	1109	-	-
		10000	2631	2631	2219	1761	1538	1398	1298	1221	1160	1109	1030	969	921	881	-	-
		30000	2631	1824	1538	1221	1067	969	900	847	804	769	714	672	638	611	-	-
		50000	2219	1538	1298	1030	900	817	759	714	678	649	602	567	538	515	-	-
100000	1761	1221	1030	817	714	649	602	567	538	515	478	450	427	409	-	-	-	
2 7/16 2 1/2 65MM	3-27 3-28 5313	5000	3118	3118	3118	2629	2297	2087	1937	1823	1732	1656	1538	1447	1375	-	-	-
		10000	3118	3118	2629	2087	1823	1656	1538	1447	1375	1315	1220	1149	1091	-	-	-
		30000	3118	2162	1823	1447	1264	1149	1066	1003	953	912	846	796	756	-	-	-
		50000	2629	1823	1538	1220	1066	969	899	846	804	769	714	672	638	-	-	-
100000	2087	1447	1220	969	846	769	714	672	638	610	567	533	506	-	-	-	-	
2 11/16 70MM	3-211 5314	5000	3311	3311	3311	2793	2440	2217	2058	1936	1839	1759	1633	1537	1460	-	-	-
		10000	3311	3311	2793	2217	1936	1759	1633	1537	1460	1396	1296	1220	1159	-	-	-
		30000	3311	2296	1936	1537	1343	1220	1132	1066	1012	968	899	846	803	-	-	-
		50000	2793	1936	1633	1296	1132	1029	955	899	854	817	758	713	678	-	-	-
100000	2217	1537	1296	1029	899	817	758	713	678	648	602	566	538	-	-	-	-	
2 15/16 75MM 3	3-215 5315 3-3	5000	3885	3885	3885	3277	2863	2601	2415	2272	2158	2064	1916	1803	1713	1639	-	-
		10000	3885	3885	3277	2601	2272	2064	1916	1803	1713	1639	1521	1431	-	-	-	-
		30000	3885	2694	2272	1803	1575	1431	1329	1250	1188	1136	1055	992	-	-	-	-
		50000	3277	2272	1916	1521	1329	1207	1121	1055	1002	985	890	837	-	-	-	-
100000	2601	1803	1521	1207	1055	958	890	837	795	761	706	664	-	-	-	-	-	
80MM 3 3/16	5316 3-33	5000	3975	3975	3975	3516	3071	2791	2591	2438	2316	2215	2056	1935	1838	1758	1632	-
		10000	3975	3975	3516	2791	2438	2215	2056	1935	1838	1758	1632	1536	-	-	-	-
		30000	3975	2890	2438	1935	1690	1536	1426	1342	1274	1219	1132	1065	-	-	-	-
		50000	3516	2438	2056	1632	1426	1295	1202	1132	1075	1028	954	898	-	-	-	-
100000	2791	1935	1632	1295	1132	1028	954	898	853	816	757	713	-	-	-	-	-	
3 7/16	3-37	5000	4812	4812	4812	4059	3546	3222	2991	2814	2673	2557	2374	-	-	-	-	-
		10000	4812	4812	4059	3222	2814	2557	2374	2234	2122	2029	1884	-	-	-	-	-
		30000	4812	3337	2814	2334	1951	1773	1646	1549	1471	1407	1306	-	-	-	-	-
		50000	4059	2814	2374	1884	1646	1495	1388	1306	1241	1187	1102	-	-	-	-	-
100000	3222	2234	1884	1495	1306	1187	1102	1037	985	942	874	-	-	-	-	-	-	
100MM 3 15/16 4	5320 3-315 3-4	5000	6673	6673	6673	5628	4917	4467	4147	3902	3707	3546	-	-	-	-	-	-
		10000	6673	6673	5628	4467	3902	3546	3291	3097	2942	2814	-	-	-	-	-	-
		30000	6673	4627	3902	3097	2706	2458	2282	2148	2040	1951	-	-	-	-	-	-
		50000	5628	3902	3291	2612	2282	2074	1925	1811	1721	1646	-	-	-	-	-	-
100000	4467	3097	2612	2074	1811	1646	1528	1438	1366	1306	-	-	-	-	-	-	-	
4 7/16 4 15/16	3-47 3-415	5000	7975	7975	7975	7054	6163	5599	5198	4891	4646	4444	-	-	-	-	-	-
		10000	7975	7975	7054	5599	4891	4444	4125	3882	3688	3527	-	-	-	-	-	-
		30000	7975	5799	4891	3882	3391	3081	2860	2692	2557	2446	-	-	-	-	-	-
		50000	7054	4891	4125	3274	2860	2599	2413	2270	2157	2063	-	-	-	-	-	-
100000	5599	3882	3274	2599	2270	2063	1915	1802	1712	1637	-	-	-	-	-	-	-	

Double Lock ratings same as standard inserts.  
For bearing selection and engineering, see page 176.

# **SEALMASTER®**

# **WORLD LEADER**

## **World's Most Specified Bearings...**

## **IN A CLASS BY THEMSELVES**



The renowned *SEALMASTER* Gold Line offers superlative performance across the broad spectrum of industrial applications. The *SEALMASTER* name is unquestionably the most respected as well as the most specified in all the varieties of mounted ball bearings now offered. The reason: *they perform* with fewer failures, less downtime, increased productivity and longer life. When you specify: "*SEALMASTER GOLD LINE BALL BEARINGS -NO SUBSTITUTIONS*" - you save your company money in any number of ways thanks to the outstanding integrity of these premium products.

## **THE GOLD STANDARD IS THE STANDARD OF EXCELLENCE**

No other commercially marketed bearings combine the exclusive features, and the resultant user benefits, with the surpassing quality of the *SEALMASTER* Gold Line. They are truly set apart from all the others, the absolute best mounted bearings that money can buy – *bar none!*

As a result, they run quieter and cooler, last much longer even in the most demanding applications, cost less to own and operate in the final analysis. Why else would more and more knowledgeable engineers continue to specify these bearings, now for over half a century? And why else would all the other bearing manufacturers try so hard to emulate the quality and performance of *SEALMASTER Gold Line Bearings*...but *fail* to match our stringent standards of excellence?

Millions of *SEALMASTER* bearings are in operation in demanding applications world-wide: in a variety of food processing industries, in material handling, air conditioning and environmental machinery, in foundries, grain handling and agriculture and in almost every other conceivable industrial service. Many of these units operate under the most severe and often hostile conditions, while still providing long life and trouble-free service, enabling users to consistently reach *and exceed* the predictable bearing fatigue life, without costly failure and unproductive downtime.

**For more information on custom solutions, designed for specific applications see page 129.**

# SKWEZLOC®

The *Outstanding*  
Bearing-To-Shaft  
Locking System

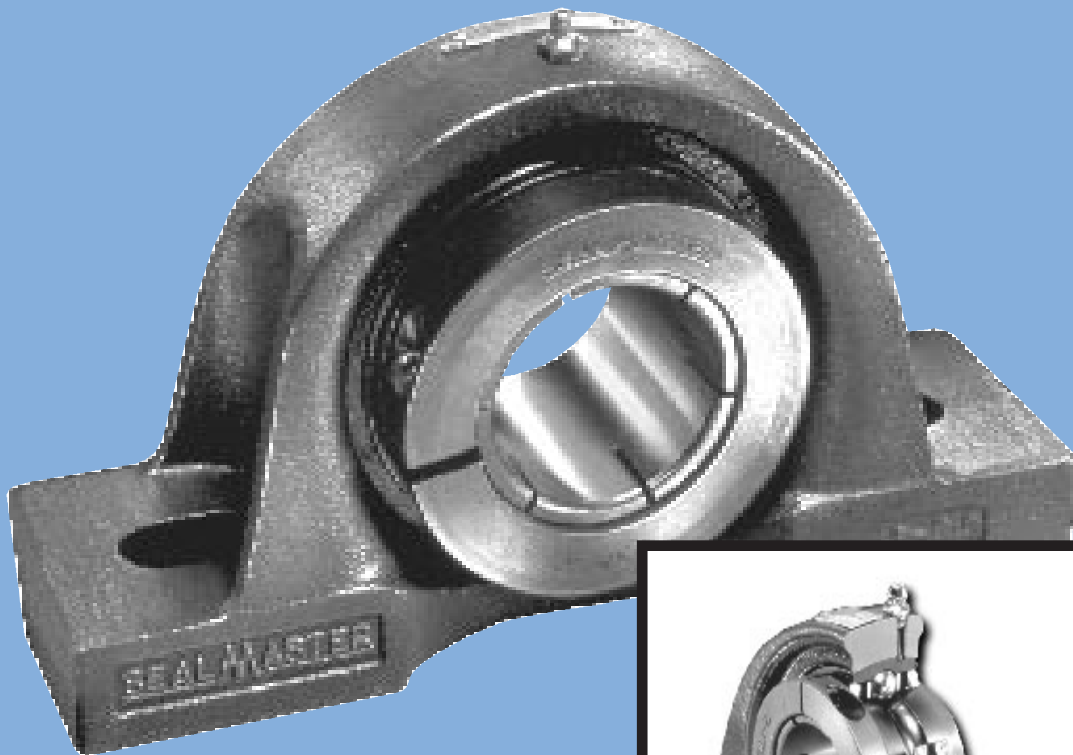

**SEALMASTER®**  
GOLD LINE BALL BEARINGS

# Specified In A Broad Range Of Demanding Applications Across Industry

## Because of Their Proven Locking Reliability

SEALMASTER Gold Line ball bearings with SKWEZLOC locking collars are applied on higher speed applications, such as fans, blowers and other higher RPM air handling and rotating machinery. They are also applied on higher speed paper, printing and textile machinery, food and grain handling mechanisms. The SKWEZLOC bearing has demonstrated its proven performance in any number of applications demanding smooth and quiet operation.

For more discussion of specific applications, see page 129.

## Widely Available From National and Local Stocks...In All Popular Designs

SEALMASTER Gold Line ball bearings with the exclusive SKWEZLOC locking collars are offered in the full range of mounted bearing configurations in both standard and medium duty designs. Most of the more popular sizes and types shown in the following table are available for immediate delivery from our strategically located national and local inventories. For additional information on availability and delivery, please consult your nearest "Emerson Power Transmission" Service Center shown on the back cover of this catalog.

Table 1 – Availability of SEALMASTER® Gold Line Bearings With SKWEZLOC® Locking Collar...Bore Sizes And Series

BORE SIZE (inches)	PILLOW BLOCKS						FLANGE UNITS						CARTRIDGE UNITS		TAKE-UP UNITS		INSERTS			
	STANDARD DUTY				MEDIUM DUTY		STANDARD DUTY			MEDIUM DUTY			STANDARD DUTY	MEDIUM DUTY	STANDARD DUTY	MEDIUM DUTY	STYLE "A" STD DUTY			
	NP-T	NPL-T	SP-T	TB-T	MP-T	EMP-T	FB-T	TFT-T	SF-T	SFT-T	SFC-T	MSF-T	MSFT-T	MFC-T	SC-T	MSC-T	ST-T	MST-T	ER-T	AR-T
3/4	■	■					■	■	■								■		■	■
15/16	■	■	■	■		■	■	■	■	■					■		■			■
1	■	■	■	■	■	■	■	■	■	■		■	■	■	■	■	■	■	■	■
1 1/8	■	■	■	■			■	■	■	■	■				■		■			■
1 3/16	■	■	■	■	■	■	■	■	■	■	■	■	■	■	■	■	■	■	■	■
1 1/4	■	■	■	■	■	■	■	■	■	■	■	■	■	■	■	■	■	■	■	■
1 3/8	■	■	■	■			■	■	■	■	■				■		■			■
1 7/16	■	■	■	■	■	■	■	■	■	■	■	■	■	■	■	■	■	■	■	■
1 1/2	■	■	■	■	■	■		■	■	■	■	■	■	■	■	■	■	■	■	■
1 5/8	■	■	■	■				■	■	■	■				■		■			■
1 11/16	■	■	■	■	■	■		■	■	■	■	■	■	■	■	■	■	■	■	■
1 3/4	■	■	■	■	■	■		■	■	■	■	■	■	■	■	■	■	■	■	■
1 15/16	■	■	■	■	■	■	■	■	■	■	■	■	■	■	■	■	■	■	■	■
2R	■	■	■	■			■	■	■	■				■		■				■
2	■	■	■		■			■	■	■	■	■	■	■	■	■	■	■	■	■
2 1/8	■	■	■					■	■	■	■				■		■			■
2 3/16	■	■	■		■	■		■	■	■	■	■	■	■	■	■	■	■	■	■
2 1/4	■	■	■		■			■	■	■	■	■	■	■	■	■	■	■	■	■
2 3/8	■	■	■					■	■	■				■		■				■
2 7/16	■	■	■		■			■	■	■				■		■				■

n = Available in this size/series



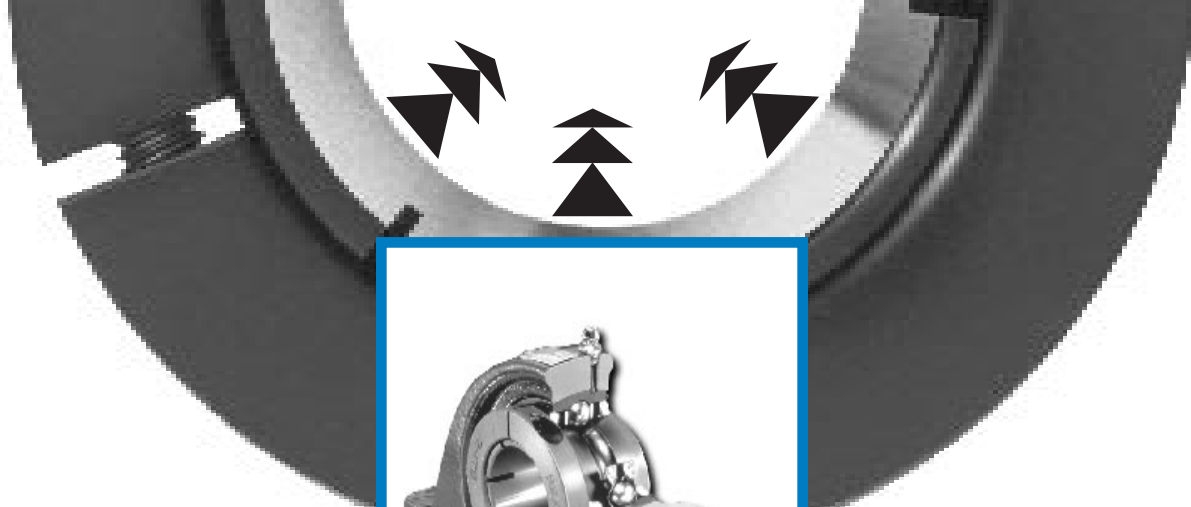

## “Rings True” – Every Time...

Because the SKWEZLOC collar *centers the shaft concentrically in the bore of the bearing, the shaft runs true* and you save on bearing maintenance and replacement costs. Because there is no setscrew, shaft marring is avoided. Ballpath roundness is maintained.

## The Key to Overall Locking Performance...

The patented design of the unique SKWEZLOC locking collar puts it a *world apart* from ordinary shaft locking devices. Six equally-spaced centering surfaces (inner race fingers or extension tabs) grip the shaft and hold it tight, locating it in near-perfect concentricity with the race. Fretting corrosion is reduced. Balancing of the assembly is readily attained and locking reliability is maintained.

## “Putting the Collar” On Vibration...

The design of the unique SKWEZLOC collar and the near-perfect shaft centering greatly reduces out-of-balance vibrational forces that tend to shorten bearing life. Fretting corrosion is also minimized.

**Overall Locking Performance Plus All the Other GOLD LINE Bearing Features and Benefits. These exclusive engineered features set all GOLD LINE bearings apart from the others:**

- Exclusive locking pin and dimple system.
- Inner and outer races of high quality 52100 vacuum degassed steel.
- Solid base cast iron housing.
- Extra wide inner and outer races.
- Zone hardened inner race.
- Patented felt labyrinth seal.
- Unique land riding metal ball retainer.
- Black oxide coating...and many more standard features and options.

## Lock In Bearing Performance...

When you specify SEALMASTER mounted ball bearings with the exclusive SKWEZLOC locking collar, you *put a lock* on proven quality and performance. You enhance operating conditions because you automatically eliminate most of the mechanical variables that can cause premature locking failure. The “*Ballpath Roundness vs. Shaft Locking Mechanism*” test data on page 67 demonstrates graphically the low distortion characteristics that the SKWEZLOC bearing design yields in comparison to other available locking systems.



# Ballpath Roundness VS Shaft Locking Mechanism

Tests Show That SKWEZLOC<sup>®</sup> Design Maintains Ballpath Roundness Up To 6-9 Times More Effectively Than Setscrew Methods

SEALMASTER engineers have measured the relative ballpath roundness of various setscrew bearings compared to the roundness of a SEALMASTER bearing equipped with a SKWEZLOC locking collar. The results and comparisons are illustrated below. The differences – *all of which can affect bearing operation and life – are dramatic!*



Turned, Ground & Polished Shafting

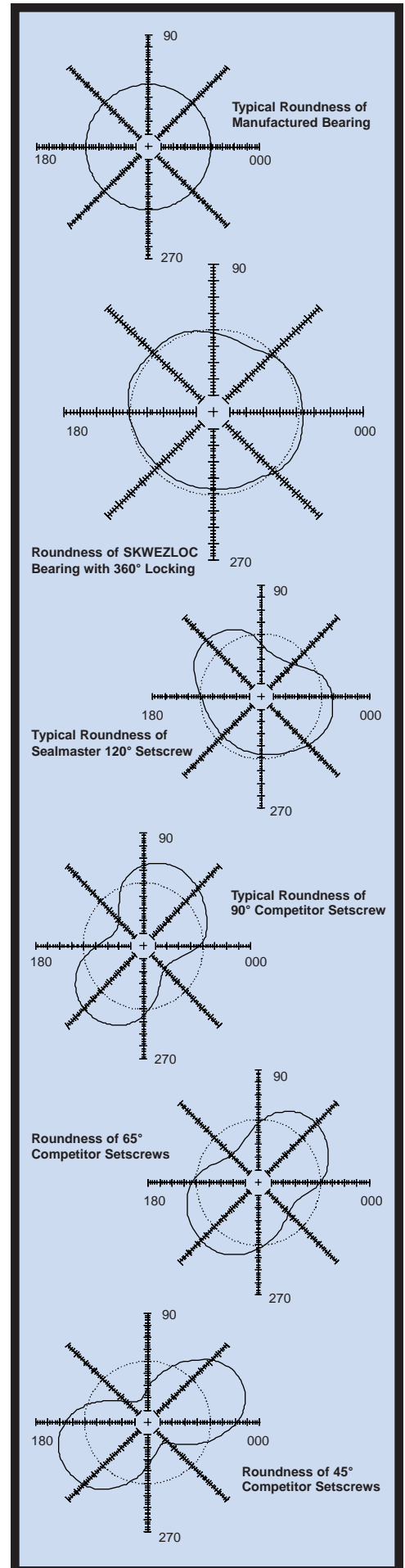
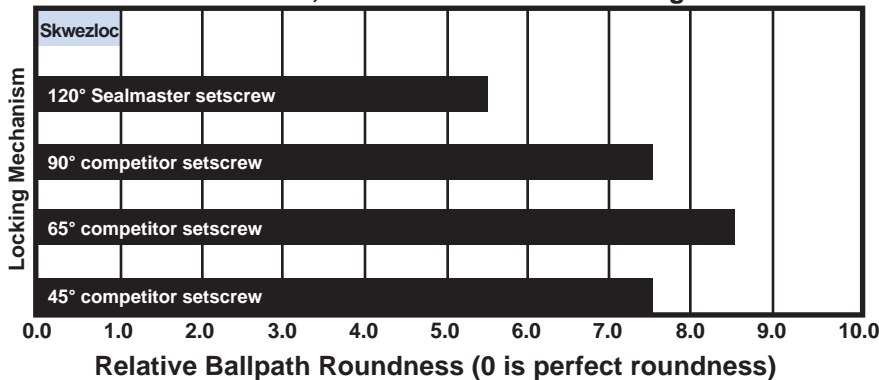

# THE GOLD STANDARD

## With The Outstanding SKWEZLOC<sup>®</sup> Bearing-To-Shaft Locking System

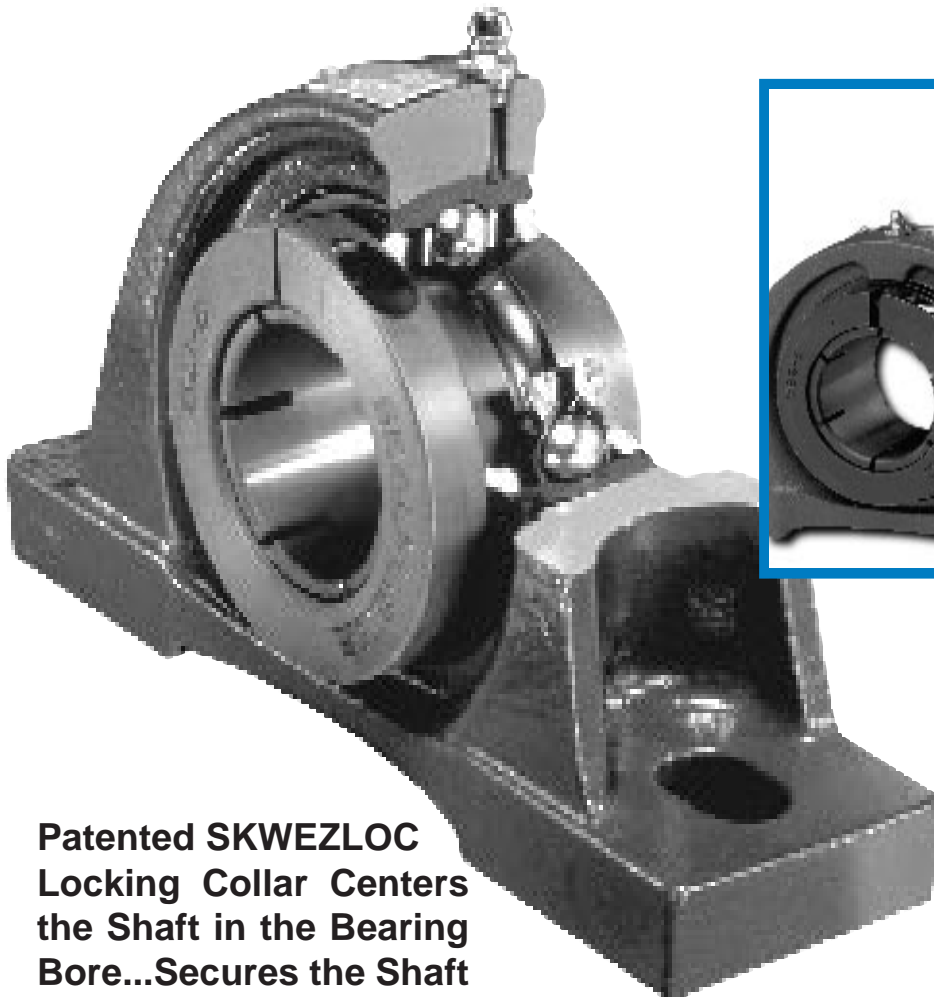

### Patented SKWEZLOC Locking Collar Centers the Shaft in the Bearing Bore...Secures the Shaft with Near-Perfect Concentricity

- Quieter smoother operation at higher speeds.
- Quickly, easily installed, removed and/or repositioned.
- Shaft protected from scoring or burring.
- Reduced out-of-balance vibrational forces and fretting corrosion.

### Smooth Operators...

With the shaft and bearing in near perfect concentricity, these premium *SEALMASTER* bearings run smoother and quieter - the qualities you equate with better performance and longer bearing life. This feature also allows operation at higher speeds than setscrew designs. **Refer to page 77 for speed capabilities.**

### Fast, Easy Installation...

Once the bearing is properly located, simply slide the SKWEZLOC locking collar into position over the extended end of the inner race. A single cap screw is properly tightened to securely lock the bearing to the shaft. Shaft release is just as easy by simply loosening the single socket head cap screw.

### Simplified Repositioning...

Some applications require the frequent repositioning of the bearing on the shaft. Eccentric collars with locking setscrews may leave a burr which can cause problems. Because of the uniform concentric hold of the SKWEZLOC collar, repositioning is easy.

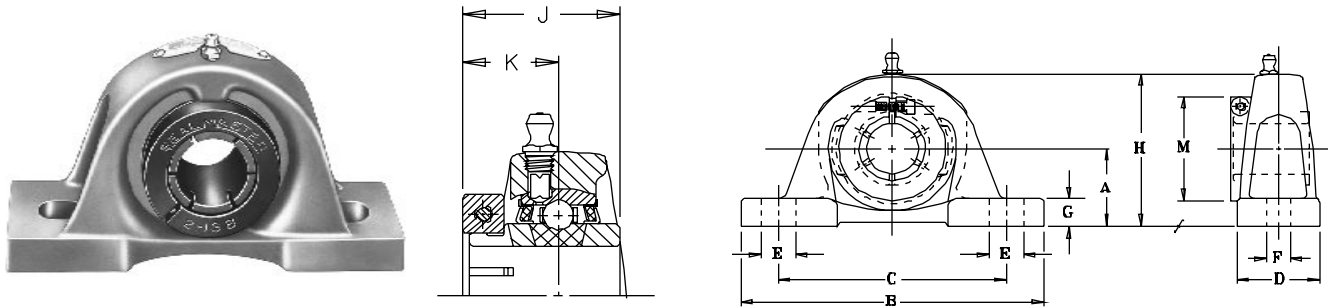

## NP-T Series Standard Duty Pillow Blocks...Skwezloc Locking

SHAFT DIAM. IN	PART NO.	BRG. NO.	Dimensions in Inches													BOLT SIZE IN.	UNIT WT.
			A	B	C		D	E	F	G	H	J	K	M			
					MIN.	MAX.											
3/4	NP-12T	2-012T	1 5/16	5	3 3/8	4 1/8	1 1/2	3/4	7/16	1/2	2 9/16	1 9/32	25/32	1 3/4	3/8	2.0	
15/16 1	NP-15T NP-16T	2-015T 2-1T	1 7/16	5 1/2	3 7/8	4 3/8	1 1/2	5/8	7/16	1/2	2 13/16	1 7/16	7/8	1 15/16	3/8	2.4	
1 1/8 1 3/16 1 1/4	NP-18T NP-19T NP-20RT	2-12T 2-13T 1-14T	1 11/16	6 1/2	4 7/16	5 1/16	1 7/8	13/16	9/16	9/16	3 3/8	1 9/16	15/16	2 3/16	1/2	3.8	
1 1/4 1 3/8 1 7/16	NP-20T NP-22T NP-23T	2-14T 2-16T 2-17T	1 7/8	6 9/16	4 11/16	5 5/16	1 7/8	13/16	9/16	5/8	3 3/4	1 3/4	1 1/16	2 7/16 2 9/16	1/2	4.8	
1 1/2 1 9/16	NP-24T NP-25T	2-18T 2-19T	1 15/16	7 1/4	4 7/8	5 7/8	2 1/8	1	9/16	11/16	3 15/16	2	1 1/4	2 11/16	1/2	6.0	
1 5/8 1 11/16 1 3/4	NP-26T NP-27T NP-28T	2-110T 2-111T 2-112T	2 1/8	7 1/2	5 7/16	6 1/16	2 1/8	13/16	9/16	11/16	4 1/4	2	1 1/4	2 13/16 2 15/16	1/2	6.8	
1 15/16 2	NP-31T NP-32RT	2-115T 1-2T	2 1/4	8 1/8	6	6 1/2	2 3/8	7/8	11/16	3/4	4 9/16	2 3/32	1 11/32	3 3/8	5/8	8.5	
2 2 1/8 2 3/16	NP-32T NP-34T NP-35T	2-2T 2-22T 2-23T	2 1/2	8 5/8	6 1/2	7	2 3/8	7/8	11/16	3/4	5	2 1/4	1 3/8	3 1/2 3 5/8	5/8	10.3	
2 1/4 2 3/8 2 7/16	NP-36T NP-38T NP-39T	2-24T 2-26T 2-27T	2 3/4	9 1/2	6 7/8	7 5/8	2 3/4	1	11/16	7/8	5 9/16	2 5/8	1 5/8	4 1/16 4 1/8	5/8	14.9	

## NPL-T Series Standard Duty Pillow Blocks...Skwezloc Locking

SHAFT DIAM. IN	PART NO.	BRG. NO.	Dimensions in Inches													BOLT SIZE IN.	UNIT WT.
			A	B	C		D	E	F	G	H	J	K	M			
					MIN.	MAX.											
3/4	NPL-12T	2-012T	1 1/4	5	3 3/8	4 1/8	1 1/2	3/4	7/16	7/16	2 1/2	1 9/32	25/32	1 3/4	3/8	1.8	
15/16 1	NPL-15T NPL-16T	2-015T 2-1T	1 5/16	5 1/2	3 7/8	4 3/8	1 1/2	5/8	7/16	1/2	2 11/16	1 7/16	7/8	1 15/16	3/8	2.2	
1 1/8 1 3/16 1 1/4	NPL-18T NPL-19T NPL-20RT	2-12T 2-13T 1-14T	1 9/16	6 1/2	4 7/16	5 1/16	1 7/8	13/16	9/16	7/16	3 1/4	1 9/16	15/16	2 3/16	1/2	3.8	
1 1/4 1 3/8 1 7/16	NPL-20T NPL-22T NPL-23T	2-14T 2-16T 2-17T	1 13/16	6 9/16	4 11/16	5 5/16	1 7/8	13/16	9/16	9/16	3 11/16	1 3/4	1 1/16	2 7/16 2 9/16	1/2	4.7	
1 1/2 1 9/16	NPL-24T NPL-25T	2-18T 2-19T	1 15/16	7 1/4	4 7/8	5 7/8	2 1/8	1	9/16	11/16	3 15/16	2	1 1/4	2 11/16	1/2	6.0	
1 5/8 1 11/16 1 3/4	NPL-26T NPL-27T NPL-28T	2-110T 2-111T 2-112T	2 1/16	7 1/2	5 7/16	6 1/16	2 1/8	13/16	9/16	5/8	4 3/16	2	1 1/4	2 13/16 2 15/16	1/2	6.5	
1 15/16 2	NPL-31T NPL-32RT	2-115T 1-2T	2 3/16	8 1/8	6	6 1/2	2 3/8	7/8	11/16	11/16	4 1/2	2 3/32	1 11/32	3 3/8	5/8	8.4	
2 2 1/8 2 3/16	NPL-32T NPL-34T NPL-35T	2-2T 2-22T 2-23T	2 7/16	8 5/8	6 1/2	7	2 3/8	7/8	11/16	11/16	4 15/16	2 1/4	1 3/8	3 1/2 3 5/8	5/8	10.2	
2 1/4 2 3/8 2 7/16	NPL-36T NPL-38T NPL-39T	2-24T 2-26T 2-27T	2 11/16	9 1/2	6 7/8	7 5/8	2 3/4	1	11/16	13/16	5 1/2	2 5/8	1 5/8	4 1/16 4 1/8	5/8	14.7	

For Load Ratings, see page 77. For Standard Duty SKWEZLOC Bearing Inserts, see page 76. See page 70 for seal arrangements. For custom seals see page 188.



MOUNTED BALL BEARINGS

**SEALMASTER®**

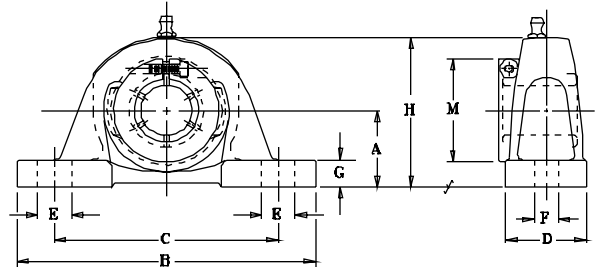
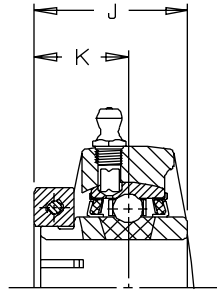

## SP-T Series Standard Duty Pillow Blocks...Skwezloc Locking

SHAFT DIAM. IN MM	PART NO.	BRG. NO.	Dimensions in Inches												BOLT SIZE IN.	UNIT WT.
			A	B	C		D	E	F	G	H	J	K	M		
					MIN.	MAX.										
15/16 1	SP-15T SP-16T	2-015T 2-1T	1 3/4	7	5 1/8	5 5/8	2	3/4	9/16	9/16	3 5/16	1 7/16	7/8	1 15/16	1/2	3.8
1 1/8 1 3/16 1 1/4	SP-18T SP-19T SP-20RT	2-12T 2-13T 1-14T	2	7 1/2	5 3/8	6 1/8	2	7/8	9/16	5/8	3 7/8	1 9/16	15/16	2 3/16	1/2	5.2
1 1/4 1 3/8 1 7/16	SP-20T SP-22T SP-23T	2-14T 2-16T 2-17T	2 3/8	8 1/4	5 5/8	6 7/8	2 1/4	1 1/4	3/4	3/4	4 1/2	1 3/4	1 1/16	2 7/16 2 9/16	5/8	7.3
1 1/2 1 9/16	SP-24T SP-25T	2-18T 2-19T	2 5/16	8 1/2	5 7/8	7 1/8	2 3/8	1 1/4	3/4	3/4	4 9/16	2	1 1/4	2 11/16	5/8	7.9
1 5/8 1 11/16 1 3/4	SP-26T SP-27T SP-28T	2-110T 2-111T 2-112T	2 3/8	8 3/4	5 7/8	7 1/8	2 3/8	1 1/4	3/4	3/4	4 5/8	2	1 1/4	2 13/16 2 15/16	5/8	8.4
1 15/16 2	SP-31T SP-32RT	2-115T 1-2T	2 3/4	10 1/2	6 3/4	8 1/2	2 1/2	1 1/2	3/4	7/8	5 5/16	2 3/32	1 11/32	3 3/8	5/8	12.2
2 2 1/8 2 3/16	SP-32T SP-34T SP-35T	2-2T 2-22T 2-23T	3 1/8	11 1/4	7 5/8	9 3/8	2 3/4	1 1/2	3/4	7/8	5 15/16	2 1/4	1 3/8	3 1/2 3 5/8	5/8	14.7
2 1/4 2 3/8 2 7/16	SP-36T SP-38T SP-39T	2-24T 2-26T 2-27T	3 1/8	11 1/2	7 7/8	9 3/8	3	1 1/2	7/8	7/8	6 1/16	2 5/8	1 5/8	4 1/16 4 1/8	3/4	17.7

For Load Ratings, see page 77.

For Standard Duty SKWEZLOC Bearing Inserts, see page 76.



**Single Lip Contact Seal**  
Available on all sizes. Recommended where moisture conditions prevail. To specify, add suffix "C" (SP-16TC).



**Felt Seal Standard**  
Positive sealing for low, medium, and high speed operation.

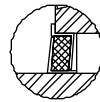

**Hi-Temp Seal**  
Available as an option where operating temperatures are in 250-400° range. (See seal options on page 188).

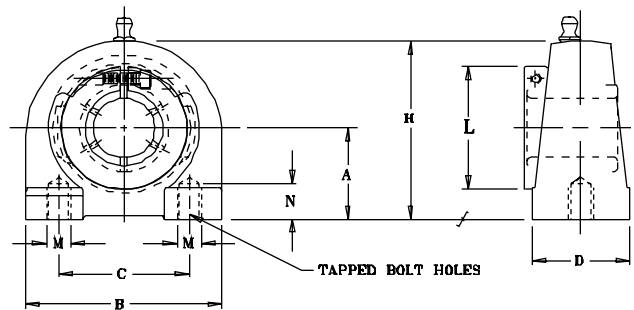
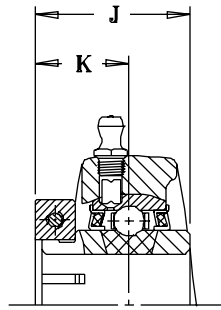

\* Bearing reversed in housing for collar clearance.

## TB-T Series Tapped Base Pillow Blocks...Skwezloc Locking

SHAFT DIAM. IN	PART NO.	BRG. NO.	Dimensions in Inches								N MIN. TAP DEPTH	M BOLT UNC. THREAD	UNIT WT.
			A	B	C	D	H	J	K	L			
3/4	*TB-12T	2-012T	1 5/16	3 1/8	2	1 1/2	2 9/16	1 9/32	25/32	1 3/4	1/2	3/8-16	1.8
15/16 1	TB-15T TB-16T	2-015T 2-1T	1 7/16	3	2	1 1/2	2 13/16	1 7/16	7/8	1 15/16	1/2	3/8-16	2.0
1 1/8 1 3/16 1 1/4	TB-18T TB-19T TB-20RT	2-12T 2-13T 1-14T	1 11/16	4	3	1 1/2	3 13/32	1 9/16	15/16	2 3/16	5/8	7/16-14	3.7
1 1/4 1 3/8 1 7/16	TB-20T TB-22T TB-23T	2-14T 2-16T 2-17T	1 7/8	4 1/4	3 1/4	1 7/8	3 3/4	1 3/4	1 1/16	2 7/16 2 9/16	3/4	1/2-13	4.8
1 1/2 1 9/16	TB-24T TB-25T	2-18T 2-19T	1 15/16	4 5/8	3 1/2	1 7/8	3 15/16	2	1 1/4	2 11/16	3/4	1/2-13	6.3
1 5/8 1 11/16 1 3/4	TB-26T TB-27T TB-28T	2-110T 2-111T 2-112T	2 1/8	5	3 3/4	2	4 1/4	2	1 1/4	2 13/16 2 15/16	3/4	1/2-13	6.8
1 15/16 2	TB-31T TB-32RT	2-115T 1-2T	2 1/4	5 1/2	4	2	4 5/8	2 3/32	1 11/32	3 3/8	7/8	5/8-11	8.6

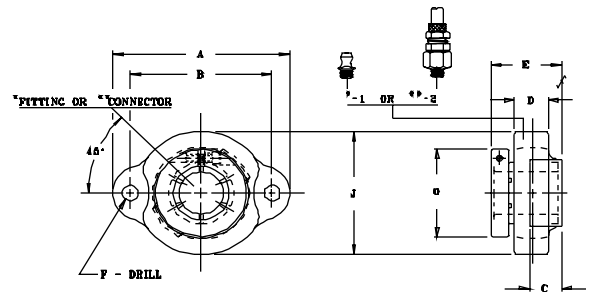
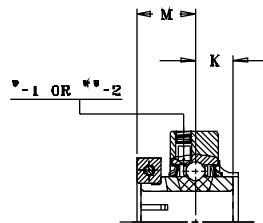

## TFT-T Series Standard Duty Two-Bolt Flange Units...Skwezloc Locking

SHAFT DIAM. IN	PART NO.	BRG. NO.	Dimensions in Inches										UNIT WT.
			A	B	C	D	E	F	J	K	M	O	
15/16 1	TFT-15TC TFT-16TC	2-015TC 2-1TC	3 3/4	3	11/16	23/32	1 1/2	25/64	2 3/4	9/16	7/8	1 15/16	1.6
1 1/8 1 3/16 1 1/4	TFT-18TC TFT-19TC TFT-20RT	2-12TC 2-13TC 1-14T	4 7/16	3 9/16	13/16	7/8	1 5/8	25/64	3 1/4	5/8	15/16	2 3/16	2.3
1 1/4 1 3/8 1 7/16	TFT-20TC TFT-22TC TFT-23TC	2-14TC 2-16TC 2-17TC	4 7/8	3 15/16	7/8	15/16	1 13/16	25/64	3 11/16	11/16	1 1/16	2 7/16 2 9/16	3.0

\* To specify, add -1 suffix, as TFT-15TC-1, etc.  
\*\*To specify, add -2 suffix, as TFT-15TC-2, etc.

For load ratings, see page 77.  
For standard duty SKWEZLOC Inserts, see page 76. See page 70 for seal arrangements.

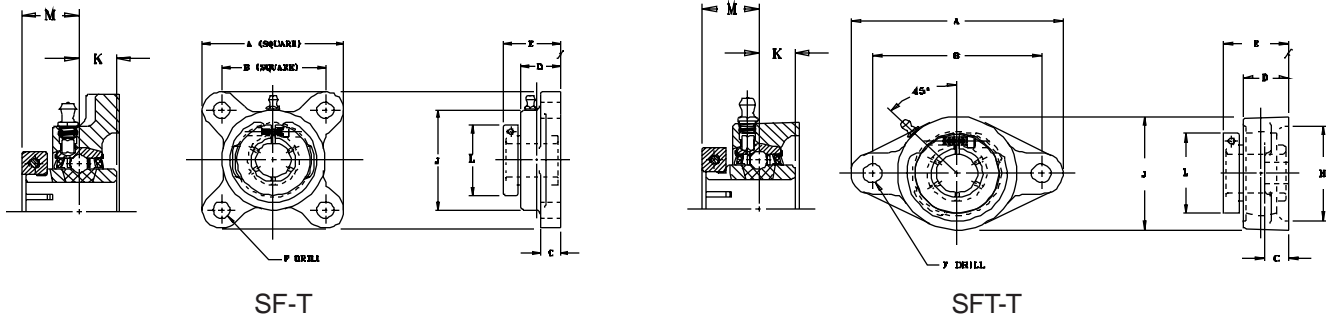

## SF-T Series Standard Duty Four-Bolt Flange Units...Skwezloc Locking

SHAFT DIAM. IN	PART NO.	BRG. NO.	Dimensions in Inches										UNIT WT.
			A	B	C	D	E	F	J	K	L	M	
3/4	SF-12T	2-012T	3 3/8	2 1/2	7/16	15/16	1 11/32	25/64	2 3/8	1/2	1 3/4	25/32	1.6
15/16 1	SF-15T SF-16T	2-015T 2-1T	3 3/4	2 3/4	17/32	1 1/32	1 1/2	15/32	2 23/32	9/16	1 15/16	7/8	2.3
1 1/8 1 3/16 1 1/4	SF-18T SF-19T SF-20RT	2-12T 2-13T 1-14T	4 1/4	3 1/4	17/32	1 11/64	1 5/8	15/32	3 7/32	5/8	2 3/16	15/16	3.8
1 1/4 1 3/8 1 7/16	SF-20T SF-22T SF-23T	2-14T 2-16T 2-17T	4 5/8	3 5/8	9/16	1 11/32	1 13/16	17/32	3 23/32	11/16	2 7/8 2 9/16	1 1/16	4.4
1 1/2 1 9/16	SF-24T SF-25T	2-18T 2-19T	5 1/8	4	9/16	1 1/2	2 5/64	17/32	4 5/64	3/4	2 11/16	1 1/4	5.8
1 5/8 1 11/16 1 3/4	SF-26T SF-27T SF-28T	2-110T 2-111T 2-112T	5 3/8	4 1/8	9/16	1 9/16	2 7/64	19/32	4 21/64	3/4	2 13/16 2 15/16	1 1/4	6.0
1 15/16 2	SF-31T SF-32RT	2-115T 1-2T	5 5/8	4 3/8	9/16	1 9/16	2 7/32	19/32	4 9/16	3/4	3 3/8	1 11/32	7.0
2 2 1/8 2 3/16	SF-32T SF-34T SF-35T	2-2T 2-22T 2-23T	6 3/8	5 1/8	13/16	1 3/4	2 3/8	21/32	5 1/4	7/8	3 1/2 3 5/8	1 3/8	11.1
2 1/4 2 3/8 2 7/16	SF-36T SF-38T SF-39T	2-24T 2-26T 2-27T	6 7/8	5 5/8	13/16	1 15/16	2 3/4	21/32	5 7/16	1	4 1/16 4 1/8	1 5/8	13.0

## SFT-T Series Standard Duty Two-Bolt Flange Units...Skwezloc Locking

SHAFT DIAM. IN	PART NO.	BRG. NO.	Dimensions in Inches											UNIT WT.
			A	B	C	D	E	F	H CORED	J	K	L	M	
3/4	SFT-12T	2-012T	4 13/32	3 17/32	7/16	15/16	1 11/32	13/32	2	2 3/8	1/2	1 3/4	25/32	1.3
15/16 1	SFT-15T SFT-16T	2-015T 2-1T	4 7/8	3 57/64	17/32	1 1/32	1 1/2	15/32	2 3/8	2 3/4	9/16	1 15/16	7/8	1.8
1 1/8 1 3/16 1 1/4	SFT-18T SFT-19T SFT-20RT	2-12T 2-13T 1-14T	5 9/16	4 19/32	17/32	1 11/64	1 5/8	15/32	2 7/8	3 1/4	5/8	2 3/16	15/16	2.4
1 1/4 1 3/8 1 7/16	SFT-20T SFT-22T SFT-23T	2-14T 2-16T 2-17T	6 1/8	5-1/8	9/16	1 11/32	1 13/16	17/32	3 5/16	3 3/4	11/16	2 7/16 2 9/16	1 1/16	3.5
1 1/2 1 9/16	SFT-24T SFT-25T	2-18T 2-19T	6 3/4	5 21/32	9/16	1 1/2	2 5/64	17/32	3 1/2	4 1/8	3/4	2 11/16	1 1/4	4.8
1 5/8 1 11/16 1 3/4	SFT-26T SFT-27T SFT-28T	2-110T 2-111T 2-112T	7 1/16	5 27/32	9/16	1 9/16	2 7/64	19/32	3 7/8	4 3/8	3/4	2 13/16 2 15/16	1 1/4	5.3
1 15/16 2	SFT-31T SFT-32RT	2-115T 1-2T	7 7/16	6 3/16	9/16	1 9/16	2 7/32	19/32	4	4 9/16	3/4	3 3/8	1 11/32	6.0
2 2 1/8 2 3/16	SFT-32T SFT-34T SFT-35T	2-2T 2-22T 2-23T	8 1/2	7 1/4	13/16	1 3/4	2 3/8	21/32	4 1/4	5 1/4	7/8	3 1/2 3 5/8	1 3/8	9.0

For Load Ratings, see page 77.

For Standard Duty SKWEZLOC Bearing Inserts, see page 76. See page 70 for seal arrangements. For custom seals, see page 188.

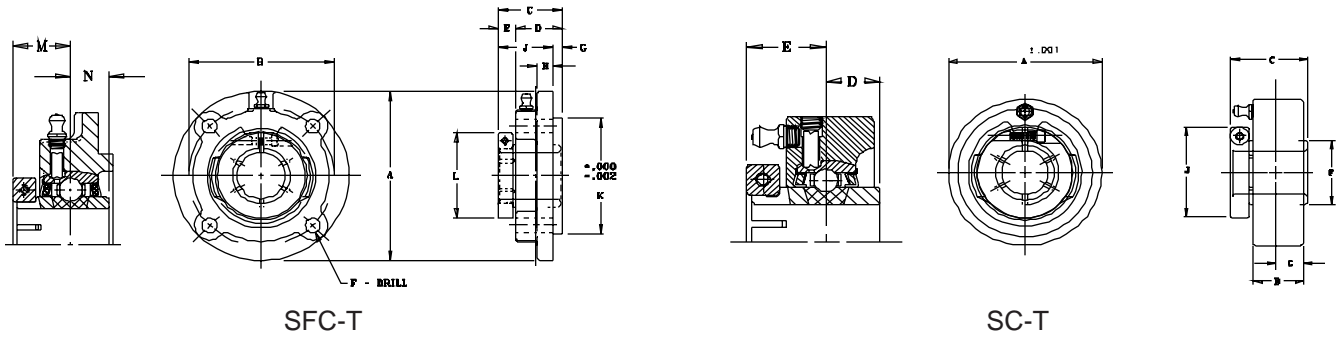

## SFC-T Series Standard Duty Flange Cartridge Units...Skwezloc Locking

SHAFT DIAM. IN	PART NO.	BRG. NO.	Dimensions In Inches													UNIT WT.
			A	B	C	D	E	F	G	H	J	K	L	M	N	
1 1/8 1 3/16 1 1/4	SFC-18T SFC-19T SFC-20RT	2-12T 2-13T 1-14T	4 3/8	3 5/8	1 5/8	1 3/16	7/16	3/8	1/4	3/8	1 3/8	3.000	2 3/16	15/16	11/16	3.2
1 1/4 1 3/8 1 7/16	SFC-20T SFC-22T SFC-23T	2-14T 2-16T 2-17T	5	4 1/8	1 3/4	1 1/4	1/2	7/16	3/8	3/8	1 3/8	3.375	2 7/16 2 9/16	1 1/16	11/16	4.2
1 1/2 1 9/16	SFC-24T SFC-25T	2-18T 2-19T	5 1/4	4 3/8	2	1 15/32	17/32	7/16	7/16	7/16	1 9/16	3.625	2 11/16	1 1/4	3/4	5.0
1 5/8 1 11/16 1 3/4	SFC-26T SFC-27T SFC-28T	2-110T 2-111T 2-112T	6 1/8	5 1/8	2	1 7/16	9/16	1/2	7/16	7/16	1 9/16	4.250	2 13/16 2 15/16	1 1/4	3/4	6.3
1 15/16 2	SFC-31T SFC-32RT	2-115T 1-2T	6 1/8	5 1/8	2 3/32	1 15/32	5/8	1/2	15/32	7/16	1 5/8	4.250	3 3/8	1 11/32	3/4	7.1
2 2 1/8 2 3/16	SFC-32T SFC-34T SFC-35T	2-2T 2-22T 2-23T	6 3/8	5 3/8	2 1/4	1 5/8	5/8	1/2	5/8	7/16	1 5/8	4.500	3 1/2 3 5/8	1 3/8	7/8	8.1
2 1/4 2 3/8 2 7/16	SFC-36T SFC-38T SFC-39T	2-24T 2-26T 2-27T	7 1/8	6	2 5/8	1 7/8	3/4	9/16	7/8	1/2	1 3/4	5.000	4 1/16 4 1/8	1 5/8	1	11.7

## SC-T Series Standard Duty Cartridge Units...Skwezloc Locking

SHAFT DIAM. IN	PART NO.	BRG. NO.	Dimensions In Inches								UNIT WT.
			A	B	C	D	E	F	G	J	
15/16* 1*	SC-15T SC-16T	2-015T 2-1T	3 1/8	1 1/32	1 7/16	9/16	7/8	1 3/8	9/16	1 15/16	1.9
1 1/8* 1 3/16* 1 1/4	SC-18T SC-19T SC-20RT	2-12T 2-13T 1-14T	3 1/2	1 3/32	1 9/16	5/8	15/16	1 19/32	9/16	2 1/16	2.5
1 1/4 1 3/8 1 7/16	SC-20T SC-22T SC-23T	2-14T 2-16T 2-17T	3 7/8	1 7/32	1 3/4	11/16	1 1/16	1 55/64	5/8	2 7/16 2 9/16	3.2
1 1/2 1 9/16	SC-24T SC-25T	2-18T 2-19T	4 3/16	1 15/32	2	3/4	1 1/4	2 1/16	3/4	2 11/16	4.1
1 5/8 1 11/16 1 3/4	SC-26T SC-27T SC-28T	2-110T 2-111T 2-112T	4 3/8	1 7/16	2	3/4	1 1/4	2 19/64	23/32	2 13/16 2 15/16	4.5
1 15/16	SC-31T	2-115T	4 9/16	1 15/32	2 3/32	3/4	1 11/32	2 15/32	3/4	3 3/8	4.9
2 2 1/8 2 3/16	SC-32T SC-34T SC-35T	2-2T 2-22T 2-23T	4 15/16	1 19/32	2 1/4	7/8	1 3/8	2 23/32	27/32	3 1/2 3 5/8	5.8
2 1/4 2 3/8 2 7/16	SC-36T SC-38T SC-39T	2-24T 2-26T 2-27T	5 7/8	1 5/8	2 5/8	1	1 5/8	2 63/64	13/16	4 1/16 4 1/8	9.0

\*Misalignment capability reduced.

For Load Ratings, see page 77.

For Standard Duty SKWEZLOC Bearing Inserts, see page 76. See page 70 for seal arrangements. For custom seals, see page 188.



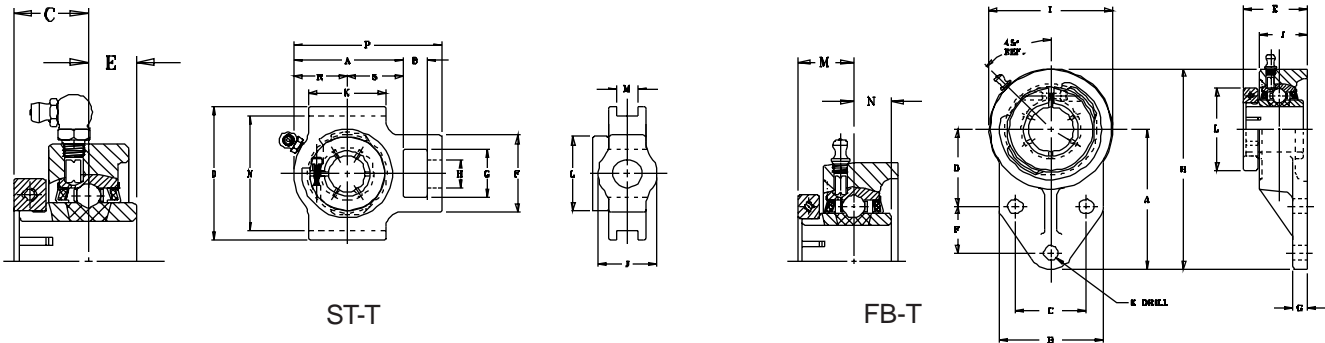

## ST-T Series Standard Duty Take-Up Units...Skwezloc Locking

SHAFT DIAM. IN	PART NO.	BRG. NO.	Dimensions in Inches																	UNIT WT.
			A	B	C	E	F	G	H Core	J Hub	K	L	M	N	O	P	R	S		
3/4	ST-12T	2-012T	2 11/16	5/8	25/32	1/2	2	1 1/4	3/4	1 3/8	2	1 3/4	17/32	3	3 1/2	3 11/16	1 5/16	1 3/8	2.2	
15/16 1	ST-15T ST-16T	2-015T 2-1T	2 13/16	5/8	7/8	9/16	2	1 1/4	3/4	1 1/2	2	1 15/16	17/32	3	3 1/2	3 13/16	1 3/8	1 7/16	2.8	
1 1/8 1 3/16 1 1/4	ST-18T ST-19T ST-20RT	2-12T 2-13T 1-14T	3 7/16	5/8	15/16	5/8	2 3/16	1 7/16	7/8	1 3/4	2 1/4	2 3/16	17/32	3 1/2	4	4 7/16	1 11/16	1 3/4	3.6	
1 1/4 1 3/8 1 7/16	ST-20T ST-22T ST-23T	2-14T 2-16T 2-17T	3 15/16	5/8	1 1/16	11/16	2 1/2	1 7/16	7/8	1 3/4	2 1/2	2 7/16 2 9/16	17/32	3 1/2	4	5 1/16	2	1 15/16	4.3	
1 1/2 1 9/16	ST-24T ST-25T	2-18T 2-19T	4 5/16	3/4	1 1/4	3/4	3 1/4	1 15/16	1 1/8	2 1/8	3 1/4	2 11/16	11/16	4	4 1/2	5 11/16	2 3/16	2 1/8	6.3	
1 5/8 1 11/16 1 3/4	ST-26T ST-27T ST-28T	2-110T 2-111T 2-112T	4 5/16	3/4	1 1/4	3/4	3 1/4	1 15/16	1 1/8	2 3/16	3 1/4	2 13/16 2 15/16	11/16	4	4 5/8	5 11/16	2 1/4	2 1/16	6.3	
1 15/16 2	ST-31T ST-32RT	2-115T 1-2T	4 1/2	3/4	1 11/32	3/4	3 1/4	1 15/16	1 1/8	2 3/16	3 3/8	3 3/8	11/16	4	4 5/8	5 7/8	2 5/16	2 3/16	6.6	
2 2 1/8 2 3/16	ST-32T ST-34T ST-35T	2-2T 2-22T 2-23T	5	1	1 3/8	7/8	4	2 1/2	1 3/8	2 1/4	3 3/4	3 1/2 3 5/8	1 1/16	5 1/8	5 3/4	6 3/4	2 9/16	2 7/16	10.4	
2 1/4 2 3/8 2 7/16	ST-36T ST-38T ST-39T	2-24T 2-26T 2-27T	5 5/8	1 1/4	1 5/8	1	4	2 1/2	1 3/8	2 3/8	4	4 1/16 4 1/8	1 1/16	5 1/8	5 3/4	7 5/8	2 15/16	2 11/16	13.4	

## FB-T Series Standard Duty Three-Bolt Flange Units...Skwezloc Locking

SHAFT DIAM. IN	PART NO.	BRG. NO.	Dimensions in Inches														UNIT WT.
			A	B	C	D	E	F	G	H	I	J	K	L	M	N	
3/4	FB-12T	2-012T	3	2 3/8	1 1/2	1 11/16	1 13/32	7/8	5/16	4 1/4	2 1/2	1	25/64	1 3/4	25/32	1/2	1.4
15/16 1	FB-15T FB-16T	2-015T 2-1T	3 3/8	2 1/2	1 5/8	1 13/16	1 9/16	1 1/8	3/8	4 3/4	2 3/4	1 1/8	25/64	1 15/16	7/8	9/16	2.3
1 1/8 1 3/16 1 1/4	FB-18T FB-19T FB-20RT	2-12T 2-13T 1-14T	3 3/4	2 3/4	1 7/8	2 1/16	1 11/16	1 1/4	3/8	5 3/8	3 1/4	1 1/4	25/64	2 3/16	15/16	5/8	3.2
1 1/4 1 3/8 1 7/16	FB-20T FB-22T FB-23T	2-14T 2-16T 2-17T	4 1/4	3 1/4	2	2 3/8	1 15/16	1 1/4	1/2	6 1/8	3 3/4	1 7/16	33/64	2 7/16 2 9/16	1 1/16	11/16	3.4
1 15/16 2	FB-31T FB-32RT	2-115T 1-2T	5 3/16	5 3/16	2 3/4	2 15/16	2 7/32	1 5/8	1/2	7 1/2	4 5/8	1 1/2	33/64	3 3/8	1 11/32	3/4	5.7

For Load Ratings, see page 77.

For Standard Duty SKWEZLOC Bearing Inserts, see page 76.

See page 70 for seal arrangements. For custom seals, see page 188.

# SEALMASTER<sup>®</sup> MOUNTED BALL BEARINGS

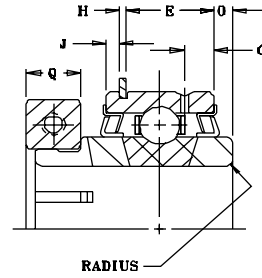
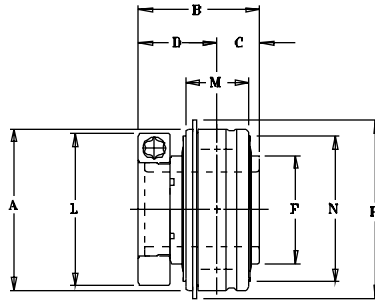

## ER-T Series Style "A" Extended Inner Ring Bearing Assemblies...Skwezloc Locking

SHAFT DIAM. IN	BRG NO.	Dimensions in Inches															UNIT WT.	
		A	B	C	D	E	F	G	H	J	L	M	N	RAD	O	P		Q
3/4	ER-12T	47MM	1 9/32	13/32	7/8	31/64	1 3/16	11/64	3/64	3/32	1 3/4	5/8	1 5/8	.040	.094	2 1/16	3/8	.56
		1.8504																
1	ER-16T	52MM	1 7/16	33/64	59/64	39/64	1 3/8	13/64	3/64	3/32	1 15/16	3/4	1 55/64	.040	.135	2 17/64	3/8	.68
		2.0472																
1 1/8	ER-18T	62MM	1 9/16	5/8	15/16	11/16	1 19/32	7/32	1/16	1/8	2 3/16	7/8	2 5/32	.040	.187	2 21/32	3/8	.93
1 1/4	ER-20T	72MM	1 3/4	11/16	1 1/16	3/4	1 55/64	7/32	1/16	1/8	2 7/16	15/16	2 9/16	.040	.219	3 5/64	7/16	1.37
											ER-23T	2.8346						
1 1/2	ER-24T	80MM	2	3/4	1 1/4	29/32	2 1/16	1/4	1/16	1/8	2 11/16	1 3/32	2 53/64	.062	.203	3 13/32	7/16	2.00
		3.1496																
1 11/16	ER-27T	85MM	2	3/4	1 1/4	29/32	2 19/64	1/4	1/16	1/8	2 15/16	1 3/32	3 1/16	.062	.203	3 19/32	7/16	2.31
1 15/16	ER-31T	90MM	2 3/32	3/4	1 11/32	29/32	2 15/32	19/64	3/32	1/8	3 3/8	1 1/8	3 7/32	.062	.188	3 25/32	9/16	2.43
		3.5433																
2	ER-32T	100MM	2 1/4	7/8	1 3/8	31/32	2 23/32	19/64	3/32	1/8	3 1/2	1 3/16	3 9/16	.080	.281	4 3/16	9/16	3.00
2 7/16	ER-39T	110MM	2 5/8	1	1 5/8	1 1/32	2 63/64	19/64	3/32	1/8	4 1/8	1 1/4	3 15/16	.080	.375	4 37/64	11/16	4.00

See load ratings, see page 77.  
For standard duty SKWEZLOC Bearing Inserts, see page 76.

## Series Style "A" "ER" Mounting Fits Table

ER HOUSING DIMENSION RECOMMENDATIONS (INCHES)										
SHAFT SIZES	OUTSIDE DIA. OF CARTRIDGE		STATIONARY HOUSING				REVOLVING HOUSING			
	DIAMETERS		DIAMETERS		THEORETICAL FIT		DIAMETERS		THEORETICAL FIT	
	MAX.	MIN.	MAX.	MIN.	TIGHT	LOOSE	MAX.	MIN.	TIGHT	LOOSE
1/2 - 3/4	1.8506	1.8498	1.8508	1.8505	.0001	.0010	1.8503	1.8500	.0006	.0005
7/8 - 1	2.0474	2.0464	2.0474	2.0473	.0001	.0010	2.0469	2.0468	.0006	.0005
1 1/16 - 1 3/16	2.4413	2.4403	2.4413	2.4412	.0001	.0010	2.4408	2.4407	.0006	.0005
1 1/4 - 1 7/16	2.8348	2.8338	2.8348	2.8347	.0001	.0010	2.8343	2.8342	.0006	.0005
1 1/2 - 1 9/16	3.1498	3.1488	3.1498	3.1497	.0001	.0010	3.1493	3.1492	.0006	.0005
1 5/8 - 1 3/4	3.3466	3.3469	3.3469	3.3465	.0001	.0013	3.3463	3.3459	.0007	.0007
1 7/8 - 1 15/16	3.5434	3.5424	3.5437	3.5433	.0001	.0013	3.5431	3.5427	.0007	.0007
2 - 2 3/16	3.9371	3.9361	3.9374	3.9370	.0001	.0013	3.9368	3.9364	.0007	.0007
2 1/4 - 2 3/16	4.3308	4.3298	4.3311	4.3307	.0001	.0013	4.3305	4.3301	.0007	.0007
2 1/2 - 2 11/16	4.9214	4.9204	4.9220	4.9212	.0002	.0016	4.9213	4.9205	.0009	.0009
2 7/8 - 2 15/16	5.1181	5.1171	5.1187	5.1179	.0002	.0016	5.1180	5.1172	.0009	.0009
3 - 3 3/16	5.5119	5.5107	5.5123	5.5117	.0002	.0016	5.5116	5.5110	.0009	.0009
3 1/4 - 3 7/16	5.9056	5.9044	5.9060	5.9054	.0002	.0016	5.9053	5.9047	.0009	.0009
3 11/16 - 4	7.4806	7.4788	7.4812	7.4804	.0002	.0024	7.4802	7.4794	.0012	.0014

\* To install an ER Type bearing into a housing, push ONLY on outer ring to avoid damaging balls and races.

Note: This table is to be used as a guide for machining housings using the "ER" style "A" Extended Inner Ring Bearing.



# MOUNTED BALL BEARINGS SEALMASTER®

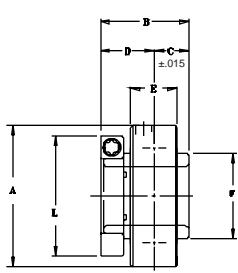

AR-T

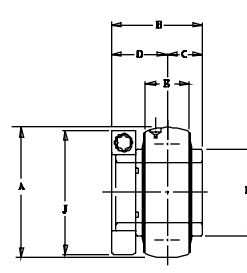
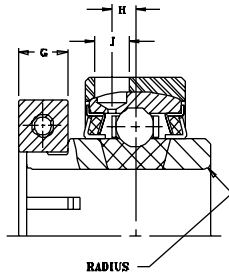

INSERT

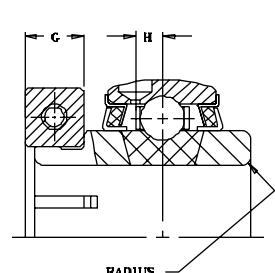

## Standard Duty Skwezloc Bearing Inserts...Skwezloc Locking

SHAFT DIAM. INCH	BRG. NO.	Dimensions in Inches										TORX CAP SCREW	UNIT WT.
		A	B	C	D	E	F	G	H	J	RADIUS		
3/4	2-012T 1.8504	47MM	1 9/32	1/2	23/32	5/8	1 3/16	3/8	9/64	1 3/4	.040	8-32 X 5/8	.6
15/16 1	2-015T 2-1T 2.0472	52MM	1 7/16	9/16	13/16	11/16	1 3/8	3/8	11/64	1 15/16	.040	8-32 X 5/8	.8
1 1/8 1 3/16 1 1/4	2-12T 2-13T 1-14T 2.4409	62MM	1 9/16	5/8	7/8	7/8	1 19/32	3/8	7/32	2 3/16	.040	8-32 X 5/8	1.2
1 1/4 1 3/8 1 7/16	2-14T 2-16T 2-17T 2.8346	72MM	1 3/4	11/16	1	15/16	1 55/64	7/16	1/4	2 7/16 2 9/16	.040	10-24 X 3/4	1.8
1 1/2 1 9/16	2-18T 2-19T 3.1496	80MM	2	3/4	1 3/16	1 3/32	2 1/16	7/16	19/64	2 11/16	.062	10-24 X 3/4	2.2
1 5/8 1 11/16 1 3/4	2-110T 2-111T 2-112T 3.3465	85MM	2	3/4	1 3/16	1 3/32	2 19/64	7/16	19/64	2 13/16 2 15/16	.062	10-24 X 3/4	2.5
1 15/16 2	2-115T 1-2T 3.5433	90MM	2 3/32	3/4	1 9/32	1 1/8	2 15/32	9/16	17/64	3 3/8	.062	1/4-20 X 1	3.0
2 2 1/8 2 3/16	2-2T 2-22T 2-23T 3.9370	100MM	2 1/4	7/8	1 5/16	1 3/16	2 23/32	9/16	19/64	3 1/2 3 5/8	.080	1/4-20 X 1	3.4
2 1/4 2 3/8 2 7/16	2-24T 2-26T 2-27T 4.3307	110MM	2 5/8	1	1 9/16	1 1/4	2 63/64	11/16	21/64	4 1/16 4 1/8	.080	5/16 -18 X 1	4.9

For load ratings, see page 77.

## AR-T Series Standard Duty Expansion Units...Skwezloc Locking

SHAFT DIAM. INCH	BRG. NO.	Dimensions in Inches											TORX CAP SCREW	UNIT WT.
		*A	B	C	D	E	F	G	H	J	L	RADIUS		
3/4	AR-2-012T	2.062	1 9/32	1/2	23/32	49/64	1 3/16	3/8	9/64	1/4	1 3/4	.040	8-32 X 5/8	.9
15/16 1	AR-2-015T AR-2-1T	2.272	1 7/16	9/16	13/16	49/64	1 3/8	3/8	11/64	1/4	1 15/16	.040	8-32 X 5/8	1.2
1 1/8 1 3/16 1 1/4	AR-2-12T AR-2-13T AR-1-14T	2.687	1 9/16	5/8	7/8	61/64	1 19/32	3/8	7/32	1/4	2 3/16	.040	8-32 X 5/8	1.7
1 1/4 1 3/8 1 7/16	AR-2-14T AR-2-16T AR-2-17T	3.140	1 3/4	11/16	1	1 1/64	1 55/64	7/16	1/4	1/4	2 7/16 2 9/16	.040	10-24 X 3/4	2.4
1 1/2 1 9/16	AR-2-18T AR-2-19T	3.375	2	3/4	1 3/16	1 11/64	2 1/16	7/16	19/64	1/4	2 11/16	.062	10-24 X 3/4	3.1
1 5/8 1 11/16 1 3/4	AR-2-110T AR-2-111T AR-2-112T	3.562	2	3/4	1 3/16	1 11/64	2 19/64	7/16	19/64	1/4	2 13/16 2 15/16	.062	10-24 X 3/4	3.3
1 15/16 2	AR-2-115T AR-1-2T	3.875	2 3/32	3/4	1 9/32	1 13/64	2 15/32	9/16	17/64	11/32	3 3/8	.062	1/4-20 X 1	4.1
2 2 1/8 2 3/16	AR-2-2T AR-2-22T AR-2-23T	4.250	2 1/4	7/8	1 5/16	1 17/64	2 23/32	9/16	19/64	11/32	3 1/2 3 5/8	.080	1/4-20 X 1	5.0
2 1/4 2 3/8 2 7/16	AR-2-24T AR-2-26T AR-2-27T	4.719	2 5/8	1	1 9/16	1 21/64	2 63/64	11/16	21/64	11/32	4 1/16 4 1/8	.080	5/16 -18 X 1	7.0

\* Tolerance +.000", -.0005"

# LOAD RATING TABLES - Standard Duty SKWEZLOC

The shaded area indicates the maximum speed ratings for SKWEZLOC (applicable on sizes available). All speeds listed are for the standard felt seal. See the seal selection for alternate seals.

Values in the table represent loads at ideal conditions with press fit mounting to the shaft. ABMA recommends de-rating of slip mounted bearings. To obtain de-rated load, divide load in table by 1.3. Values in the table represent equivalent radial loads only. For combined load determination, see **THE BEARING SELECTION SECTION**. Areas designated by "-" exceeds maximum value for standard bearings. Consult Sealmaster Application Engineering for load and speed applications not covered in this table.

NORMAL DUTY			REVOLUTIONS PER MINUTE																					
SHAFT SIZE	INSERT #	ER #	L10 HOURS	50	150	500	1000	1750	2000	2500	3500	4500	5000	5500	6000	6500	7500	8000	10000					
3/4	2-012T	ER-12T	5000	619	619	491	390	324	310	287	257	236	228	215	209	199	195	181						
			10000	583	583	390	310	257	246	228	204	188	181	175	170	166	158	154	143					
			30000	583	404	270	215	178	170	158	141	130	126	118	115	109	107	100						
			50000	491	341	228	181	150	144	133	119	110	106	103	100	97	92	90	84					
			100000	390	270	181	144	119	114	106	95	87	84	81	79	77	73	71	67					
15/16 1	2-015T 2-1T	ER-16T	5000	664	664	527	418	347	332	308	276	253	245	237	230	224	213	213						
			10000	625	625	418	332	276	264	245	219	201	194	188	183	177	169	169						
			30000	625	433	290	230	191	183	170	152	139	135	130	127	123	117	117						
			50000	527	366	245	194	161	154	143	128	118	114	110	107	104	99	99						
			100000	418	290	194	154	128	122	114	102	93	90	87	85	82	78	78						
1 1/8 1 3/16	2-12T 2-13T	ER-18T ER-19T	5000	1039	1039	825	654	543	519	482	431	396	383	370	360	351	334	334						
			10000	978	978	654	519	431	412	383	342	315	304	294	286	278	265	265						
			30000	978	678	454	360	299	286	265	237	218	211	204	198	193	184	184						
			50000	825	572	383	304	252	241	224	200	184	178	172	167	163	155	155						
			100000	654	454	304	241	200	191	178	159	146	141	136	133	129	123	123						
1 1/4 1 3/8 1 7/16	2-14T 2-16T 2-17T	ER-20T ER-22T ER-23T	5000	1290	1290	1088	864	717	686	636	569	523	505	489	475	463	-	-	-					
			10000	1290	1290	864	686	569	544	505	452	415	401	388	377	367	-	-	-					
			30000	1290	895	599	475	394	377	350	313	288	278	269	262	255	-	-	-					
			50000	1088	755	505	401	333	318	295	264	243	234	227	221	215	-	-	-					
			100000	864	599	401	318	264	253	234	210	193	186	180	175	171	-	-	-					
1 1/2	2-18T	ER-24T	5000	1638	1638	1381	1096	910	870	808	722	664	641	621	603	-	-	-	-					
			10000	1638	1638	1096	870	722	691	641	573	527	509	493	479	-	-	-	-					
			30000	1638	1136	760	603	501	479	445	397	365	353	342	332	-	-	-	-					
			50000	1381	958	641	509	422	404	375	335	308	298	288	280	-	-	-	-					
			100000	1096	760	509	404	335	321	298	266	245	236	229	222	-	-	-	-					
1 5/8 1 11/16 1 3/4	2-110T 2-111T 2-112T	ER-27T ER-28T	5000	1763	1763	1487	1180	979	937	870	777	715	690	669	-	-	-	-	-					
			10000	1763	1763	1180	937	777	744	690	617	567	548	531	-	-	-	-	-					
			30000	1763	1222	818	650	539	516	479	428	393	380	368	-	-	-	-	-					
			50000	1487	1031	690	548	455	435	404	361	332	320	310	-	-	-	-	-					
			100000	1180	818	548	435	361	345	320	286	263	254	246	-	-	-	-	-					
1 15/16	2-115T	ER-31T	5000	1760	1760	1485	1178	978	935	868	776	714	689	-	-	-	-	-	-					
			10000	1760	1760	1178	935	776	742	689	616	567	547	-	-	-	-	-	-					
			30000	1760	1221	817	649	538	515	478	427	393	379	-	-	-	-	-	-					
			50000	1485	1029	689	547	454	434	403	360	331	320	-	-	-	-	-	-					
			100000	1178	817	547	434	360	345	320	286	263	254	-	-	-	-	-	-					
2 2 1/8 2 3/16	2-2T 2-22T 2-23T	ER-32T ER-35T	5000	2176	2176	1835	1457	1209	1156	1073	1010	959	-	-	-	-	-	-	-					
			10000	2176	2176	1457	1156	959	918	852	802	762	-	-	-	-	-	-	-					
			30000	2176	1509	1010	802	665	636	591	556	528	-	-	-	-	-	-	-					
			50000	1835	1273	852	676	561	537	498	469	445	-	-	-	-	-	-	-					
NORMAL DUTY			REVOLUTIONS PER MINUTE																					
SHAFT SIZE	INSERT #	ER #	L10 HOURS	50	150	250	500	750	1000	1250	1500	1750	2000	2500	3000	3500	4000	4500	-					
2 1/4 2 3/8 2 7/16	2-24T 2-26T 2-27T	ER-36T ER-38T ER-39T	5000	2631	2631	2631	2219	1938	1761	1635	1538	1461	1398	1298	1221	1160	1109	1030	969	921	1109	881	-	-
			10000	2631	2631	2219	1761	1538	1398	1298	1221	1160	1109	1030	969	921	881	-	-	-	-	-	-	-
			30000	2631	1824	1538	1221	1067	969	900	847	804	769	714	672	638	611	-	-	-	-	-	-	-
			50000	2219	1538	1298	1030	900	817	759	714	678	649	602	567	538	515	-	-	-	-	-	-	-
			100000	1761	1221	1030	817	714	649	602	567	538	515	478	450	427	409	-	-	-	-	-		

For bearing selection and engineering, see page 176.

# SEALMASTER GOLD...NO EQUAL DIFFERENT BY DESIGN

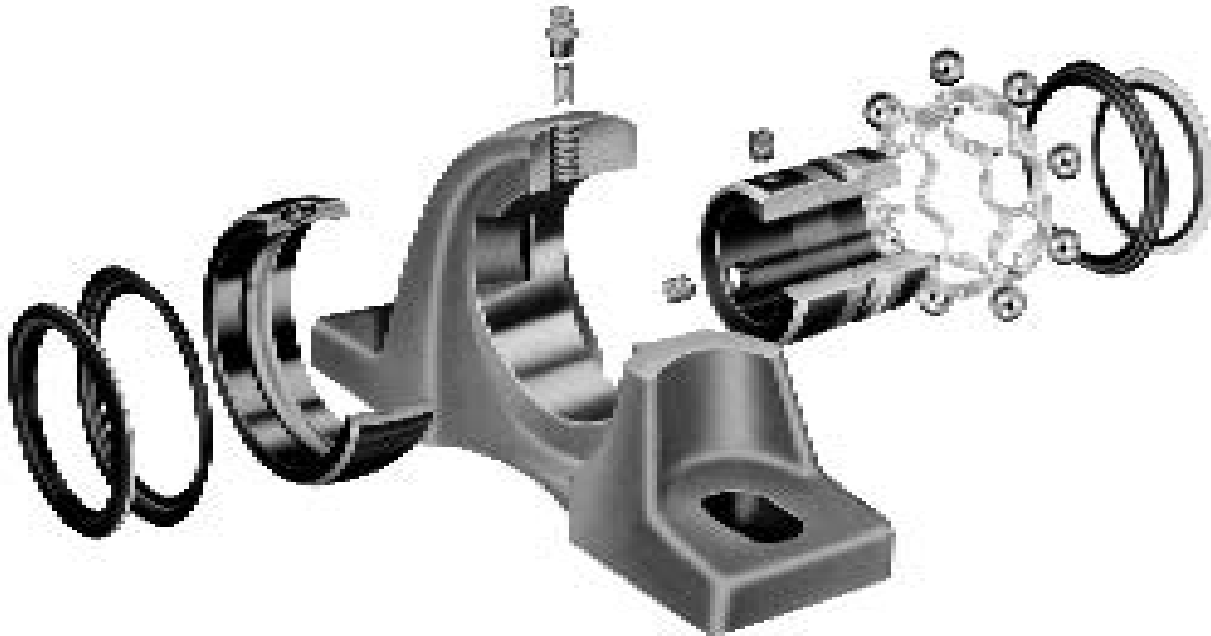

The Sealmaster Gold Bearing *contains features that work together to solve problems in a variety of applications.*

The Gold Platform also allows for *modifications and customization to suit specific applications.*

When the operating conditions demand more than off the shelf, *Sealmaster has become known as the problem solver.* Over 15,000 customized designs are running today to prove the claim...

**SEALMASTER**<sup>®</sup>  
**GOLD NO EQUAL**

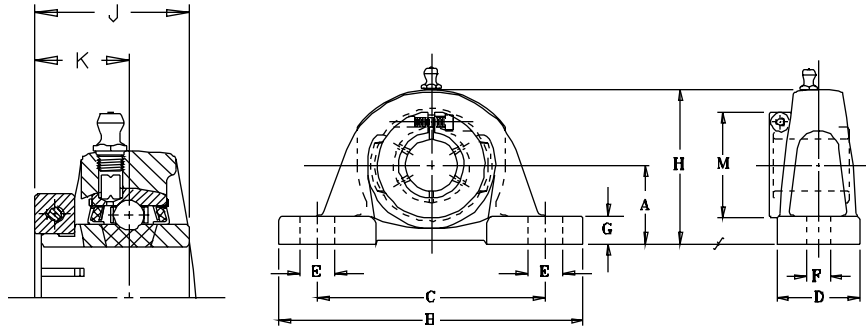

## MP-T Series Medium Duty Pillow Blocks...Skwezloc Locking

SHAFT DIAM. IN	PART NO.	BRG. NO.	Dimensions in Inches												BOLT SIZE IN.	UNIT WT.
			A	B	C		D	E	F	G	H	J	K	M		
					MIN.	MAX.										
1	MP-16T	3-1T	1 3/4	6 1/4	4 3/16	5 3/16	2	1	9/16	5/8	3 7/16	1 9/16	15/16	2 1/16	1/2	4.2
1 3/16 1 1/4	MP-19T MP-20T	3-13T 2-14T	1 7/8	6 7/8	4 1/2	5 1/2	2 1/4	1	9/16	11/16	3 13/16	1 3/4	1 1/16	2 7/16	1/2	5.7
1 7/16	MP-23T	3-17T	2 1/8	8	5	6 3/8	2 1/4	1 3/16	9/16	3/4	4 3/16	2	1 1/4	2 11/16	1/2	7.1
1 1/2	MP-24T	3-18T	2 5/16	8 3/4	5 1/2	6 3/4	2 5/8	1 1/4	11/16	13/16	4 9/16	2	1 1/4	2 13/16	5/8	9.3
1 11/16 1 3/4	MP-27T MP-28T	3-111T 3-112T	2 5/16	8 3/4	5 7/16	6 13/16	2 5/8	1 5/16	11/16	13/16	4 5/8	2 3/32	1 11/32	3 1/4	5/8	10.1
1 15/16 2	MP-31T MP-32T	3-115T 2-2T	2 1/2	9 1/2	5 15/16	7 9/16	2 7/8	1 7/16	11/16	7/8	5 3/32	2 1/4	1 3/8	3 1/2	5/8	12.3
2 3/16 2 1/4	MP-35T MP-36T	3-23T 2-24T	2 3/4	10 1/4	6 9/16	7 15/16	3 1/8	1 7/16	13/16	1 1/16	5 5/8	2 5/8	1 5/8	4 1/16	3/4	17.4

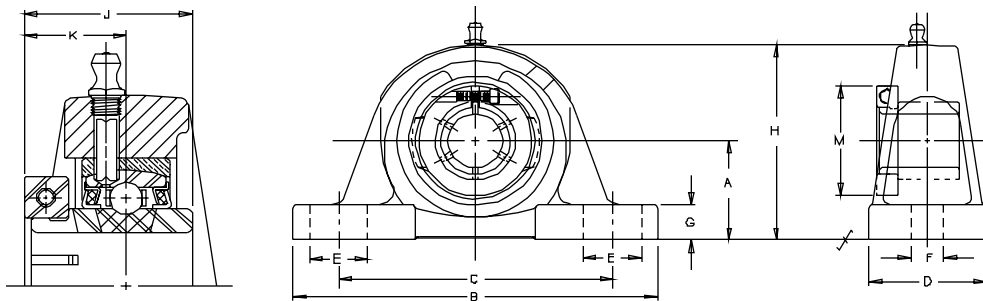

## EMP-T Series Expansion Type Pillow Blocks...Skwezloc Locking

SHAFT DIAM. IN	PART NO.	BRG. NO.	Dimensions in Inches												LIMIT OF EXPAN.	BOLT SIZE IN.	UNIT WT.
			A	B	C		D	E	F	G	H	J	K	M			
					MIN.	MAX.											
15/16 1	EMP-15T EMP-16T	AR-2-015T AR-2-1T	1 3/4	6 1/4	4 3/16	5 3/16	2	1	9/16	5/8	3 7/16	1 7/16	7/8	1 15/16	1/8	1/2	3.9
1 3/16	EMP-19T	AR-2-13T	1 7/8	6 7/8	4 1/2	5 1/2	2 1/4	1	9/16	11/16	3 13/16	1 9/16	15/16	2 3/16	1/8	1/2	5.7
1 7/16	EMP-23T	AR-2-17T	2 1/8	8	5	6 3/8	2 1/4	1 3/16	9/16	3/4	4 3/16	1 3/4	1 1/16	2 9/16	1/8	1/2	7.1
1 1/2	EMP-24T	AR-2-18T	2 5/16	8 3/4	5 1/2	6 3/4	2 5/8	1 1/4	11/16	13/16	4 9/16	2	1 1/4	2 11/16	1/8	5/8	9.3
1 11/16	EMP-27T	AR-2-111T	2 5/16	8 3/4	5 7/16	6 13/16	2 5/8	1 5/16	11/16	13/16	4 5/8	2	1 1/4	2 15/16	1/8	5/8	9.5
1 15/16	EMP-31T	AR-2-115T	2 1/2	9 1/2	5 15/16	7 9/16	2 7/8	1 7/16	11/16	7/8	5 3/32	2 3/32	1 11/32	3 3/8	3/16	5/8	12.2
2 3/16	EMP-35T	AR-2-23T	2 3/4	10 1/4	6 9/16	7 15/16	3 1/8	1 7/16	13/16	1 1/16	5 5/8	2 1/4	1 3/8	3 5/8	3/16	3/4	16.2
2 7/16	EMP-39T	AR-2-27T	3	11 1/4	7 1/8	8 7/8	3 1/4	1 5/8	13/16	1 1/16	6 1/4	2 5/8	1 5/8	4 1/8	3/16	3/4	21.2

For Load Ratings, see page 84.

For Medium Duty SKWEZLOC Bearing Inserts, see page 83. See page 70 for seal arrangements. For custom seals, see page 188.



MOUNTED BALL BEARINGS

**SEALMASTER®**

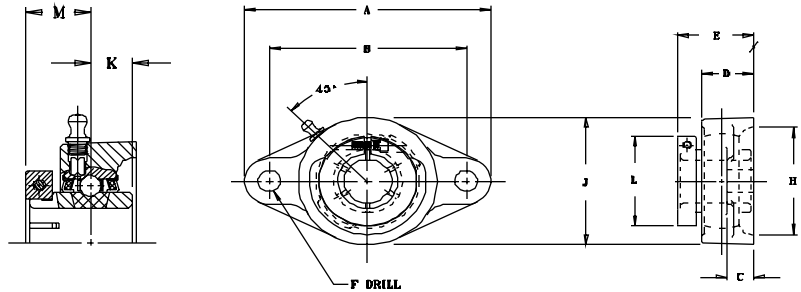

## MSFT-T Series Medium Duty Two-Bolt Flange Units...Skwezloc Locking

SHAFT DIAM. IN	PART NO.	BRG. NO.	Dimensions in Inches											UNIT WT.
			A	B	C	D	E	F	H CORED	J	K	L	M	
1	MSFT-16T	3-1T	5 9/16	4 19/32	17/32	1 11/64	1 5/8	15/32	2 7/8	3 1/4	5/8	2 1/16	15/16	2.6
1 3/16 1 1/4	MSFT-19T MSFT-20T	3-13T 2-14T	6 1/8	5 1/8	9/16	1 11/32	1 13/16	17/32	3 5/16	3 3/4	11/16	2 7/16	1 1/16	3.7
1 7/16	MSFT-23T	3-17T	6 3/4	5 21/32	9/16	1 1/2	2 5/64	17/32	3 1/2	4 1/8	3/4	2 11/16	1 1/4	4.9
1 1/2	MSFT-24T	3-18T	7 1/16	5 27/32	9/16	1 9/16	2 7/64	19/32	3 7/8	4 3/8	3/4	2 13/16	1 1/4	5.5
1 11/16 1 3/4	MSFT-27T MSFT-28T	3-111T 3-112T	7 7/16	6 3/16	9/16	1 9/16	2 7/32	19/32	4	4 9/16	3/4	3 1/4	1 11/32	6.2
1 15/16 2	MSFT-31T MSFT-32T	3-115T 2-2T	8 1/2	7 1/4	13/16	1 3/4	2 3/8	21/32	4 1/4	5 1/4	7/8	3 1/2	1 3/8	9.2

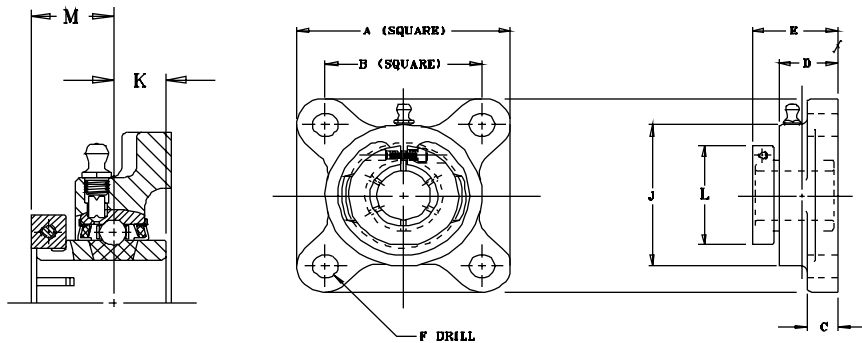

## MSF-T Series Medium Duty Four-Bolt Flange Units...Skwezloc Locking

SHAFT DIAM. IN	PART NO.	BRG. NO.	Dimensions in Inches											UNIT WT.
			A	B	C	D	E	F	J	K	L	M		
1	MSF-16T	3-1T	4 1/4	3 1/4	17/32	1 11/64	1 5/8	15/32	3 7/32	5/8	2 1/16	15/16	3.8	
1 3/16 1 1/4	MSF-19T MSF-20T	3-13T 2-14T	4 5/8	3 5/8	9/16	1 11/32	1 13/16	17/32	3 23/32	11/16	2 7/16	1 1/16	4.4	
1 7/16	MSF-23T	3-17T	5 1/8	4	9/16	1 1/2	2 5/64	17/32	4 5/64	3/4	2 11/16	1 1/4	5.8	
1 1/2	MSF-24T	3-18T	5 3/8	4 1/8	9/16	1 9/16	2 7/64	19/32	4 21/64	3/4	2 13/16	1 1/4	6.3	
1 11/16 1 3/4	MSF-27T MSF-28T	3-111T 3-112T	5 5/8	4 3/8	9/16	1 9/16	2 7/32	19/32	4 9/16	3/4	3 1/4	1 11/32	7.4	
1 15/16 2	MSF-31T MSF-32T	3-115T 2-2T	6 3/8	5 1/8	13/16	1 3/4	2 3/8	21/32	5 1/4	7/8	3 1/2	1 3/8	11.1	
2 3/16 2 1/4	MSF-35T MSF-36T	3-23T 2-24T	6 7/8	5 5/8	13/16	1 15/16	2 3/4	21/32	5 7/16	1	4 1/16	1 5/8	13.3	

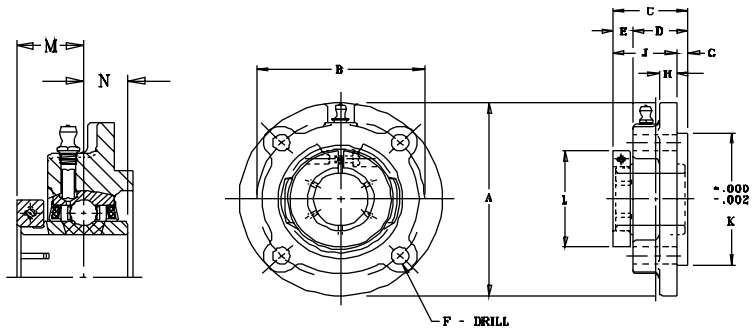

## MFC-T Series Medium Duty Flange Cartridge Units...Skwezloc Locking

SHAFT DIAM. IN	PART NO.	BRG. NO.	Dimensions In Inches													UNIT WT.
			A	B	C	D	E	F	G	H	J	K	L	M	N	
1	MFC-16T	3-1T	4 3/8	3 5/8	1 5/8	1 3/16	7/16	3/8	1/4	3/8	1 3/8	3.000	2 1/16	15/16	5/8	3.2
1 3/16 1 1/4	MFC-19T MFC-20T	3-13T 2-14T	5	4 1/8	1 3/4	1 1/4	1/2	7/16	3/8	3/8	1 3/8	3.375	2 7/16	1 11/16	11/16	4.2
1 7/16 1 1/2	MFC-23T MFC-24T	3-17T 2-18T	5 1/4	4 3/8	2	1 15/32	17/32	7/16	7/16	7/16	1 9/16	3.625	2 11/16	1 1/4	3/4	5.2
1 1/2	MFC-24HT	3-18T	6 1/8	5 1/8	2	1 7/16	9/16	1/2	7/16	7/16	1 9/16	4.250	2 13/16	1 1/4	3/4	6.3
1 11/16 1 3/4	MFC-27T MFC-28T	3-111T 3-112T	6 1/8	5 1/8	2 3/32	1 15/32	5/8	1/2	15/32	7/16	1 5/8	4.250	3 1/4	1 11/32	3/4	7.1
1 15/16 2	MFC-31T MFC-32T	3-115T 2-2T	6 3/8	5 3/8	2 1/4	1 5/8	5/8	1/2	5/8	7/16	1 5/8	4.500	3 1/2	1 3/8	7/8	8.1
2 3/16 2 1/4	MFC-35T MFC-36T	3-23T 2-24T	7 1/8	6	2 5/8	1 7/8	3/4	9/16	7/8	1/2	1 3/4	5.000	4 1/16	1 5/8	1	11.7

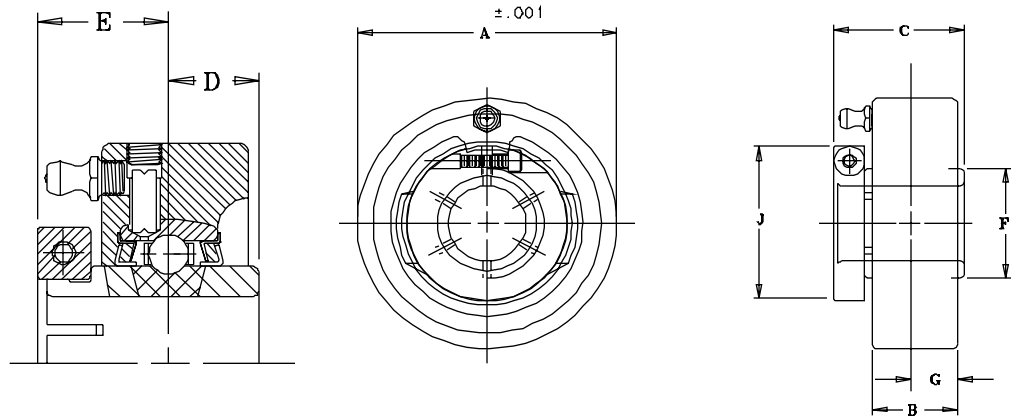

## MSC-T Series Medium Duty Cartridge Units...Skwezloc Locking

SHAFT DIAM. IN	PART NO.	BRG. NO.	Dimensions In Inches								UNIT WT.
			A	B	C	D	E	F	G	J	
1 *	MSC-16T	3-1T	3 1/2	1 3/32	1 9/16	5/8	15/16	1 19/32	9/16	2 1/16	2.5
1 3/16 1 1/4	MSC-19T MSC-20T	3-13T 2-14T	3 7/8	1 7/32	1 3/4	11/16	1 1/16	1 55/64	5/8	2 7/16	3.2
1 7/16	MSC-23T	3-17T	4 3/16	1 15/32	2	3/4	1 1/4	2 1/16	3/4	2 11/16	4.1
1 1/2	MSC-24T	3-18T	4 3/8	1 7/16	2	3/4	1 1/4	2 19/64	23/32	2 13/16	4.5
1 11/16 1 3/4	MSC-27T MSC-28T	3-111T 3-112T	4 9/16	1 15/32	2 3/32	3/4	1 11/32	2 15/32	3/4	3 1/4	4.9
1 15/16 2	MSC-31T MSC-32T	3-115T 2-2T	4 15/16	1 19/32	2 1/4	7/8	1 3/8	2 23/32	27/32	3 1/2	5.8
2 3/16 2 1/4	MSC-35T MSC-36T	3-23T 2-24T	5 7/8	1 5/8	2 5/8	1	1 5/8	2 63/64	13/16	4 1/16	9.0

\* Misalignment capability reduced.

For Load Ratings, see page 84. For Medium Duty SKWEZLOC Bearing Inserts, see page 83. See page 70 for seal arrangements. For custom seals, see page 188.



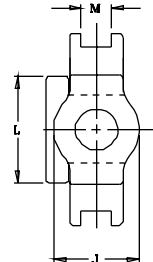
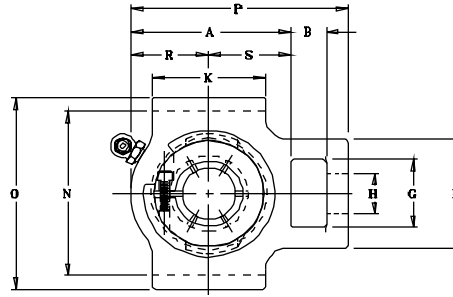
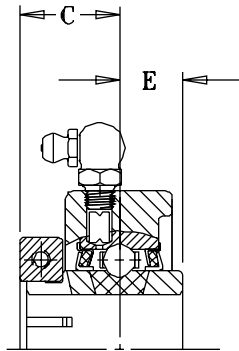

## MST-T Series Medium Duty Take-Up Units...Skwezloc Locking

SHAFT DIAM. IN	PART NO.	BRG. NO.	Dimensions In Inches																UNIT WT.
			A	B	C	E	F	G	H Core	J Hub	K	L	M	N	O	P	R	S	
1	MST-16T	3-1T	3 7/16	5/8	15/16	5/8	2 3/16	1 7/16	7/8	1 3/4	2 1/4	2 1/16	17/32	3-1/2	4	4 7/16	1 11/16	1 3/4	3.6
1 3/16 1 1/4	MST-19T MST-20T	3-13T 2-14T	3 15/16	5/8	1 1/16	11/16	2 1/2	1 7/16	7/8	1 3/4	2 1/2	2 7/16	17/32	3-1/2	4	5 1/16	2	1 15/16	4.3
1 7/16	MST-23T	3-17T	4 5/16	3/4	1 1/4	3/4	3 1/4	1 15/16	1 1/8	2 1/8	3 1/4	2 11/16	11/16	4	4 1/2	5 11/16	2 3/16	2 1/8	6.3
1 1/2	MST-24T	3-18T	4 5/16	3/4	1 1/4	3/4	3 1/4	1 15/16	1 1/8	2 3/16	3 1/4	2 13/16	11/16	4	4 5/8	5 11/16	2 1/4	2 1/16	6.3
1 11/16 1 3/4	MST-27T MST-28T	3-111T 3-112T	4 1/2	3/4	1 11/32	3/4	3 1/4	1 15/16	1 1/8	2 3/16	3 3/8	3 1/4	11/16	4	4 5/8	5 7/8	2 5/16	2 3/16	6.6
1 15/16 2	MST-31T MST-32T	3-115T 2-2T	5	1	1 3/8	7/8	4	2 1/2	1 3/8	2 1/4	3 3/4	3 1/2	1 1/16	5 1/8	5 3/4	6 3/4	2 9/16	2 7/16	10.4
2 3/16 2 1/4	MST-35T MST-36T	3-23T 2-24T	5 3/8	1 1/4	1 5/8	1	4	2 1/2	1 3/8	2 3/8	4	4 1/16	1 1/16	5 1/8	5 3/4	7 5/8	2 15/16	2 11/16	13.4

For load ratings, see page 84.

For medium duty SKWEZLOC Bearing Inserts, see page 83.

See page 70 for seal configurations.

For custom seals, see page 188.

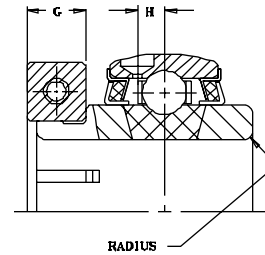
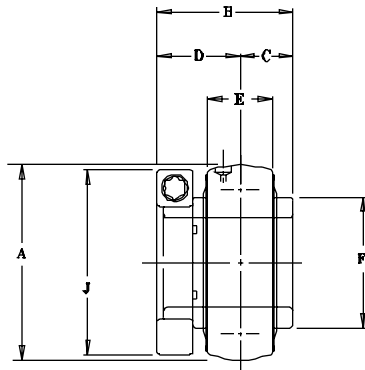

## Medium Duty Bearing Inserts...Skwezloc Locking

SHAFT DIAM. INCH	BRG. NO.	Dimensions in Inches										TORX CAP SCREW	UNIT WT.
		A	B	C	D	E	F	G	H	J	RADIUS		
1	3-1T	62MM 2.4409	1 9/16	5/8	7/8	7/8	1 19/32	3/8	7/32	2 1/16	.040	8-32 X 5/8	1.2
1 3/16	3-13T	72MM 2.8346	1 3/4	11/16	1	15/16	1 55/64	7/16	1/4	2 7/16	.040	10-24 X 3/4	1.8
1 7/16	3-17T	80MM 3.1496	2	3/4	1 3/16	1 3/32	2 1/16	7/16	19/64	2 11/16	.062	10-24 X 3/4	2.2
1 1/2	3-18T	85MM 3.3465	2	3/4	1 3/16	1 3/32	2 19/64	7/16	19/64	2 13/16	.062	10-24 X 3/4	2.5
1 11/16 1 3/4	3-111T 3-112T	90MM 3.5433	2 3/32	3/4	1 9/32	1 1/8	2 15/32	9/16	17/64	3 1/4	.062	1/4-20 X 1	3.0
1 15/16	3-115T	100MM 3.9370	2 1/4	7/8	1 5/16	1 3/16	2 23/32	9/16	19/64	3 1/2	.080	1/4-20 X 1	
2 3/16	3-23T	110MM 4.3307	2 5/8	1	1 9/16	1 1/4	2 63/64	11/16	21/64	4 1/16	.080	5/16 -18 X 1	4.9

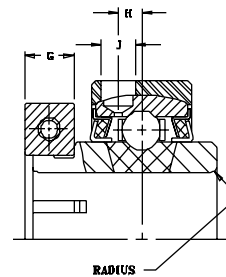
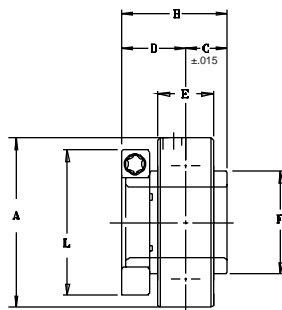

## AR-T Series Medium Duty Expansion Units...Skwezloc Locking

SHAFT DIAM. INCH	BRG. NO. AR-	Dimensions in Inches											TORX CAP SCREW	UNIT WT.
		*A	B	C	D	E	F	G	H	J	L	RADIUS		
1	AR-3-1T	2.687	1 9/16	5/8	15/16	61/64	1 19/32	3/8	7/32	1/4	2 1/16	.040	8-32 X 5/8	1.7
1 3/16	AR-3-13T	3.140	1 3/4	11/16	1 1/16	1 1/64	1 55/64	7/16	1/4	1/4	2 7/16	.040	10-24 X 3/4	2.4
1 7/16	AR-3-17T	3.375	2	3/4	1 1/4	1 11/64	2 1/16	7/16	19/64	1/4	2 11/16	.062	10-24 X 3/4	3.1
1 1/2	AR-3-18T	3.562	2	3/4	1 1/4	1 11/64	2 19/64	7/16	19/64	1/4	2 13/16	.062	10-24 X 3/4	3.3
1 11/16 1 3/4	AR-3-111T AR-3-112T	3.875	2 3/32	3/4	1 11/32	1 13/64	2 15/32	9/16	17/64	11/32	3 1/4	.062	1/4-20 X 1	4.1
1 15/16	AR-3-115T	4.250	2 1/4	7/8	1 3/8	1 17/64	2 23/32	9/16	19/64	11/32	3 1/2	.080	1/4-20 X 1	5.0
2 3/16	AR-3-23T	4.718	2 5/8	1	1 5/8	1 21/64	2 63/64	11/16	21/64	11/32	4 1/16	.080	5/16 -18 X 1	7.0

\* Tolerance +.000", -.005"

For Load Ratings, see page 84. See page 70 for seal arrangements. For custom seals, see page 188.

# LOAD RATING TABLES - Medium Duty SKWEZLOC

The shaded area indicates the maximum speed ratings for SKWEZLOC (applicable on sizes available). All speeds listed are for the standard felt seal. See the seal selection for alternate seals.

Values in the table represent loads at ideal conditions with press fit mounting to the shaft. ABMA recommends de-rating of slip mounted bearings. To obtain de-rated load, divide load in table by 1.3. Values in the table represent equivalent radial loads only. For combined load determination, see **THE BEARING SELECTION SECTION**. Areas designated by "-" exceeds maximum value for standard bearings. **Consult Sealmaster Application Engineering for load and speed applications not covered in this table.**

MEDIUM DUTY		REVOLUTIONS PER MINUTE																	
SHAFT SIZE	INSERT #	L10 HOURS	50	150	500	1000	1750	2000	2500	3500	4500	5000	5500	6000	6500	7500	8000	10000	
1	3-1T	5000	1039	1039	825	654	543	519	482	431	396	383	370	360	351	334	334	-	
		10000	978	978	654	519	431	412	383	342	315	304	294	286	278	265	265	-	
		30000	978	678	454	360	299	286	265	237	218	211	204	198	193	184	184	-	
		50000	825	572	383	304	252	241	224	200	184	178	172	167	163	155	155	-	
		100000	654	454	304	241	200	191	178	159	146	141	136	133	129	123	123	-	
1 3/16	3-13T	5000	1290	1290	1088	864	717	686	636	569	523	505	489	475	463	-	-	-	
		10000	1290	1290	864	686	569	544	505	452	415	401	388	377	367	-	-	-	
		30000	1290	895	599	475	394	377	350	313	288	278	269	262	255	-	-	-	
		50000	1088	755	505	401	333	318	295	264	243	234	227	221	215	-	-	-	
		100000	864	599	401	318	264	253	234	210	193	186	180	175	171	-	-	-	
1 7/16	3-17T	5000	1638	1638	1381	1096	910	870	808	722	664	641	621	603	-	-	-	-	
		10000	1638	1638	1096	870	722	691	641	573	527	509	493	479	-	-	-	-	
		30000	1638	1136	760	603	501	479	445	397	365	353	342	332	-	-	-	-	
		50000	1381	958	641	509	422	404	375	335	308	298	288	280	-	-	-	-	
		100000	1096	760	509	404	335	321	298	266	245	236	229	222	-	-	-	-	
1 1/2	3-18T	5000	1763	1763	1487	1180	979	937	870	777	715	690	669	-	-	-	-	-	
		10000	1763	1763	1180	937	777	744	690	617	567	548	531	-	-	-	-	-	
		30000	1763	1222	818	650	539	516	479	428	393	380	368	-	-	-	-	-	
		50000	1487	1031	690	548	455	435	404	361	332	320	310	-	-	-	-	-	
		100000	1180	818	548	435	361	345	320	286	263	254	246	-	-	-	-	-	
1 11/16 1 3/4	3-111T 3-112T	5000	1760	1760	1485	1178	978	935	868	776	714	689	-	-	-	-	-	-	
		10000	1760	1760	1178	935	776	742	689	616	567	547	-	-	-	-	-	-	
		30000	1760	1221	817	649	538	515	478	427	393	379	-	-	-	-	-	-	
		50000	1485	1029	689	547	454	434	403	360	331	320	-	-	-	-	-	-	
		100000	1178	817	547	434	360	345	320	286	263	254	-	-	-	-	-	-	
1 15/16	3-115T	5000	2176	2176	1835	1457	1209	1156	1073	1010	959	-	-	-	-	-	-	-	
		10000	2176	2176	1457	1156	959	918	852	802	762	-	-	-	-	-	-	-	
		30000	2176	1509	1010	802	665	636	591	556	528	-	-	-	-	-	-	-	
		50000	1835	1273	852	676	561	537	498	469	445	-	-	-	-	-	-	-	
MEDIUM DUTY		REVOLUTIONS PER MINUTE																	
SHAFT SIZE	INSERT #	L10 HOURS	50	150	250	500	750	1000	1250	1500	1750	2000	2500	3000	3500	4000	4500	-	
2 3/16	3-23T	5000	2631	2631	2631	2219	1938	1761	1635	1538	1461	1398	1298	1221	1160	1109	1109	-	-
		10000	2631	2631	2219	1761	1538	1398	1298	1221	1160	1109	1030	969	921	881	-	-	
		30000	2631	1824	1538	1221	1067	969	900	847	804	769	714	672	638	611	-	-	
		50000	2219	1538	1298	1030	900	817	759	714	678	649	602	567	538	515	-	-	
		100000	1761	1221	1030	817	714	649	602	567	538	515	478	450	427	409	-	-	

For bearing selection and engineering, see page 176.

# SEALMASTER® FEATURED PRODUCTS

## METRIC - SKWEZ MOUNTED BALL BEARINGS

**INCREASING GLOBAL EFFICIENCY SPRING 1997\***

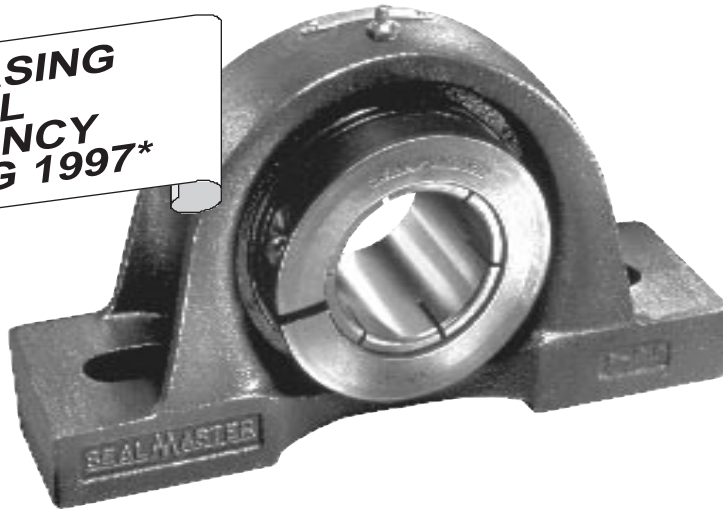

The first HIGH PERFORMANCE HARD METRIC MOUNTED BALL BEARINGS...

...Are now available with the patented SKWEZLOC Locking Collar.

### The Key to Overall Locking Performance...

The patented design of the unique SKWEZLOC locking collar puts it a *world apart* from ordinary shaft locking devices. Six equally-spaced centering surfaces (inner race fingers or extension tabs) grip the shaft and hold it tight, locating it in near-perfect concentricity with the race. Fretting corrosion is reduced. Balancing of the assembly is readily attained and locking reliability is maintained.

### "Putting the Collar"

#### On Vibration...

The design of the unique SKWEZLOC collar and the near-perfect shaft centering greatly reduces out of balance vibrational forces that tend to shorten bearing life. Fretting corrosion is also minimized.

### HARD METRIC METRIC - SKWEZ

- **Metric Dimensions.**
  - Lubrication Fitting.
  - Capscrews.
  - Collar.
- **Metric Bore.**
- **Collar Distinction.**
- **Special Metric SKWEZLOC Permanent Metal Nameplate.**

### Fast, Easy Installation...

Once the bearing is properly located, simply slide the SKWEZLOC locking collar into position over the extended end of the inner race. A single cap screw is properly tightened to securely lock the bearing to the shaft. Shaft release is just as easy by simply loosening the single socket head cap screw. (see page 200 for detailed installation instructions).

### Simplified Repositioning...

Some applications require the frequent repositioning of the bearing on the shaft. Eccentric collars with locking setscrews may leave a burr which can cause problems. Because of the uniform concentric hold of the SKWEZLOC collar, repositioning is easy.



SKWEZLOC

### Metric Dimensions

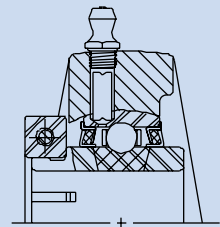

### Distinctive Metric Collar



### Metric Capscrews

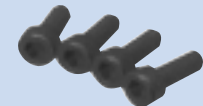

### Special Nameplate



### Metric Bore

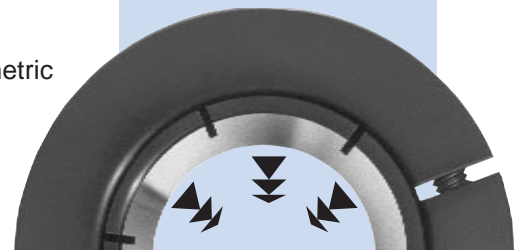

Because the World has become smaller, Sealmaster has developed a hard metric product line. Ideal for replacing problematic bearings on imported machinery. Readily available for easy assembly on OEM equipment manufactured for international exportation.

\*Contact Sealmaster for more information.

# SEALMASTER® FEATURED PRODUCTS

## BEVERAGE BEARING MOUNTED BALL BEARINGS

*There is no more need to worry about...*

- n Beverage Spillovers
- n High pressure Washes
- n Moisture
- n Caustic Cleansers
- n Grease wash out
- n Inadequate Lubrication
- n Broken Glass
- n Seal Failure

## The Gold Beverage Bearing is Designed Specifically for the Beverage Industry.

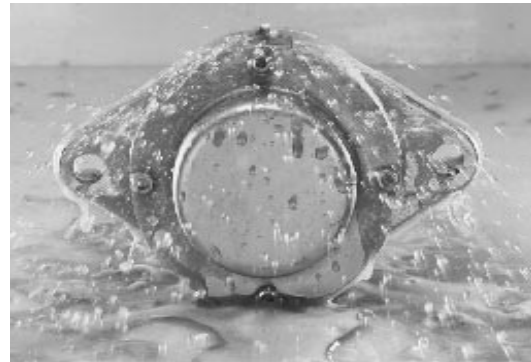

1. Sealmaster began with a blank piece of paper...no preconceived notions.
2. Sealmaster engineers evaluated fillers, cappers, crowners, coolers, conveyors, seamers, rinsers, washers, warmers, packers, palletizers & accumulation tables.
3. Beverage industry leaders played an active role developing the product.
4. Prototypes were produced and installed on the most challenging applications.
5. Bearings were routinely inspected by both Sealmaster customers and engineers.
6. Grease coatings, seals, and races were individually tested for over 2 years until optimal performance was achieved.
7. The results exceeded customer expectations, and today major beverage companies specify the Sealmaster Gold Beverage Bearing...NO SUB!

### **Features Include...**

- n Thin Dense Chrome Plated Races.
- n Fluoropolymer Coated Corrosion Resistant Housing.
- n Stainless Steel End Cap (available in 2 & 4 bolt flanges).
- n Stainless Steel Backside Shield and Double Gasket Assembly.
- n Spring Loaded Contact Seals and Flingers.
- n Drainage slot in shield & gasket assembly.
- n Stainless Steel Balls.
- n Stainless Zerk and Washers.
- n Solid Base Housing.
- n Gold Line 120° Set Screw Spacing.
- n Self Aligning  $\pm 2^\circ$ .
- n Coated Set Screws.
- n Wide Outer Race.

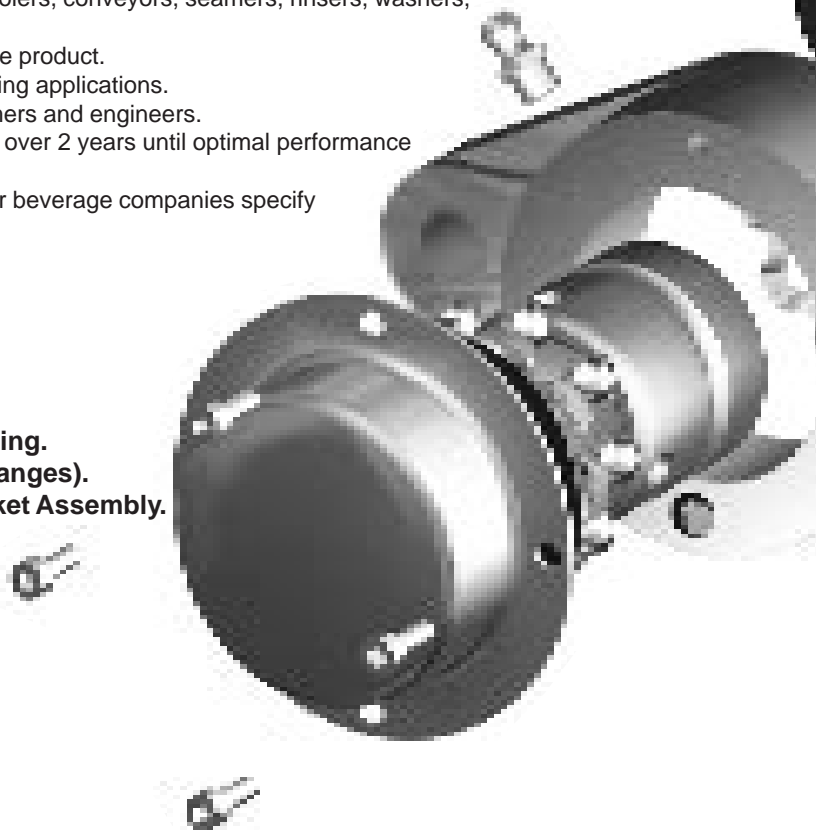

# DIFFERENT...BY DESIGN!

## SEALMASTER COATINGS PROTECT

**THIN DENSE CHROME (TDC)** is a coating that resists corrosion 10 to 15 times longer than standard bearing materials. TDC totally covers the entire surface area of both races and is between 10-15% harder than industry standard bearing races.

**FLUOROPOLYMER COATING** covering the cast iron housing is compound matrix three protective layer designed to resist any:

- n Peeling.
- n Most cleaning solvents up to PH levels of eleven.
- n Moisture.
- n High Pressure Washes.
- n Abrasion.



TDC Coating



Unprotected

### Available Optional Features

#### SEALED (Non-relubricable)

Attach "S" to the end of any unit number  
i.e. BFT-31S

#### FOOD GRADE GREASE (USDA)

Attach the suffix FGG to the end of unit number. i.e. BPL-20R FGG  
Made to order only.

#### 3 Layer

#### Stainless Back Side Shield and Buna Gaskets

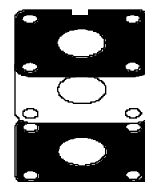
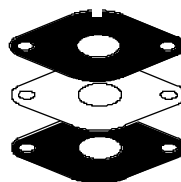

Assembled standard with...  
2 & 4 bolt flanges size 1" to 2 3/16" bores.



## Actual field testing has proven that the Gold Beverage Bearing can last up to 2 years longer than ordinary bearings.

Today, sophisticated preventative maintenance programs usually identify bearings that are in the process of failing before a catastrophic emergency occurs. Clearly, in the case of a breakdown, the costs at a high speed filling facility add up quickly. Consider 1,800 cans per minute at 58 cents per can at over an hour downtime to replace bearings and you get the picture quickly. It is because of this that your company pays close attention to potential failures. Instead of focusing on downtime, we know you want to maximize your uptime. Even scheduled maintenance costs you production which takes away from manufacturing efficiencies, not to mention the indirect labor costs, actual replacement costs of the bearing and any consequential damage that may have occurred. The bottom line: *the Sealmaster Gold beverage bearing contributes to your long term production reliability and the most uptime.*

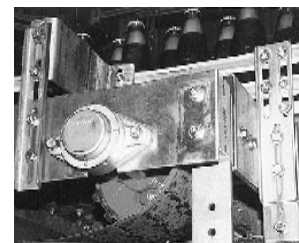

For more information on wet environments, see page 136.

For specifications on Beverage Bearings, see Featured Product Dimension Tables on page 93.

# SEALMASTER® FEATURED PRODUCTS

## CORROSION-RESISTANT CR DUTY MOUNTED BALL BEARINGS

**Corrosion Duty Bearing Housings** Many harsh atmospheres can contaminate bearing rolling elements and housings, thereby reducing bearing life. SEALMASTER Gold Line CR Duty bearings, with corrosion-resistant polymer coating on the housings and application proven sealing elements to protect the ball bearings, are designed specifically to perform in these difficult ambient environments.

Apply these bearing units in a variety of services where they may be subjected to moisture, corrosive, and abrasive atmospheres. Typical examples include:

- Food Processing Plants.
- Food Packaging Plants.
- Beverage, Brewing, Bottling Plants.
- Meat, Poultry, Seafood Processing Plants.
- Dairy Industry Plants.
- Sugar Processing Plants.
- Drug and Pharmaceutical Plants.
- Chemical Processing Plants.
- Rubber and Plastics Plants.
- Pulp and Paper Mills.
- Car and Truck Washes.
- Refrigeration and Freezer Plants.
- Agricultural Harvesting Machinery
- Municipal (Sand/Salt) Treatment Equipment.
- Marine and Naval Applications.
- A Broad Range of Material Handling Services.



## THE GOLD STANDARD CORROSION RESISTANCE BENEFITS

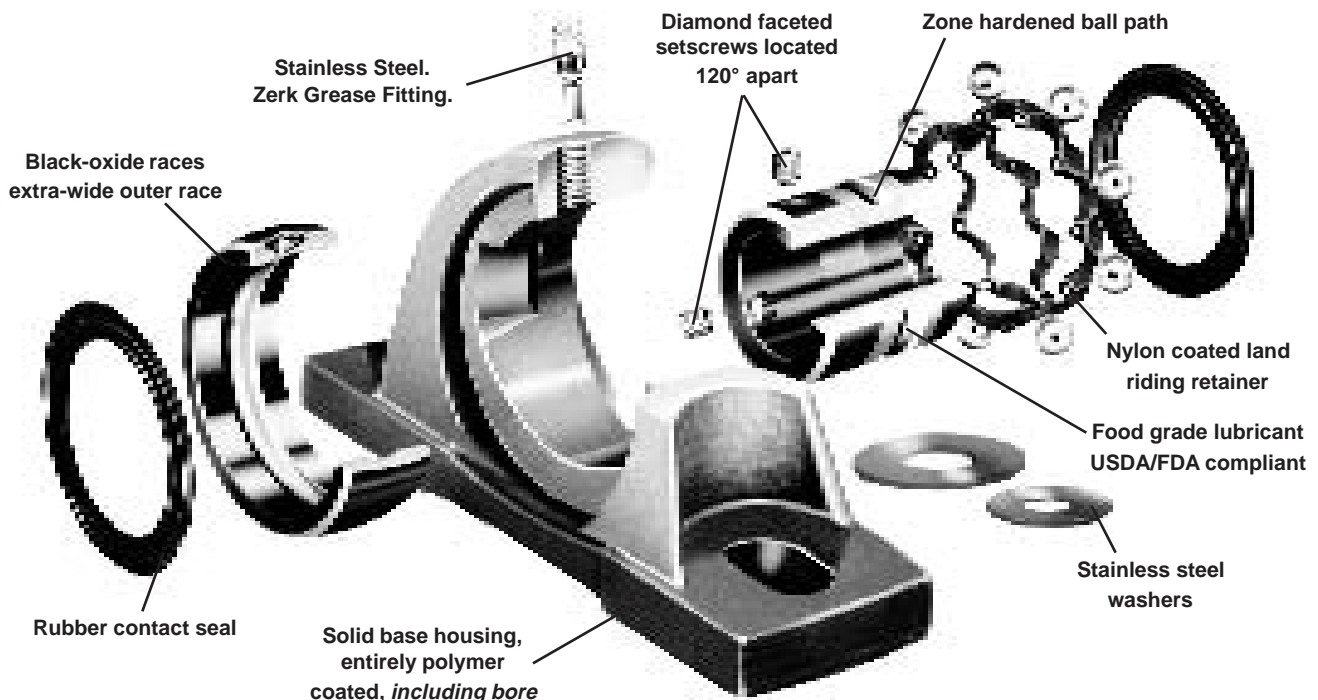

# DIFFERENT...BY DESIGN!

## CORROSION-RESISTANT POLYMER COATING

... A Schematic Representation

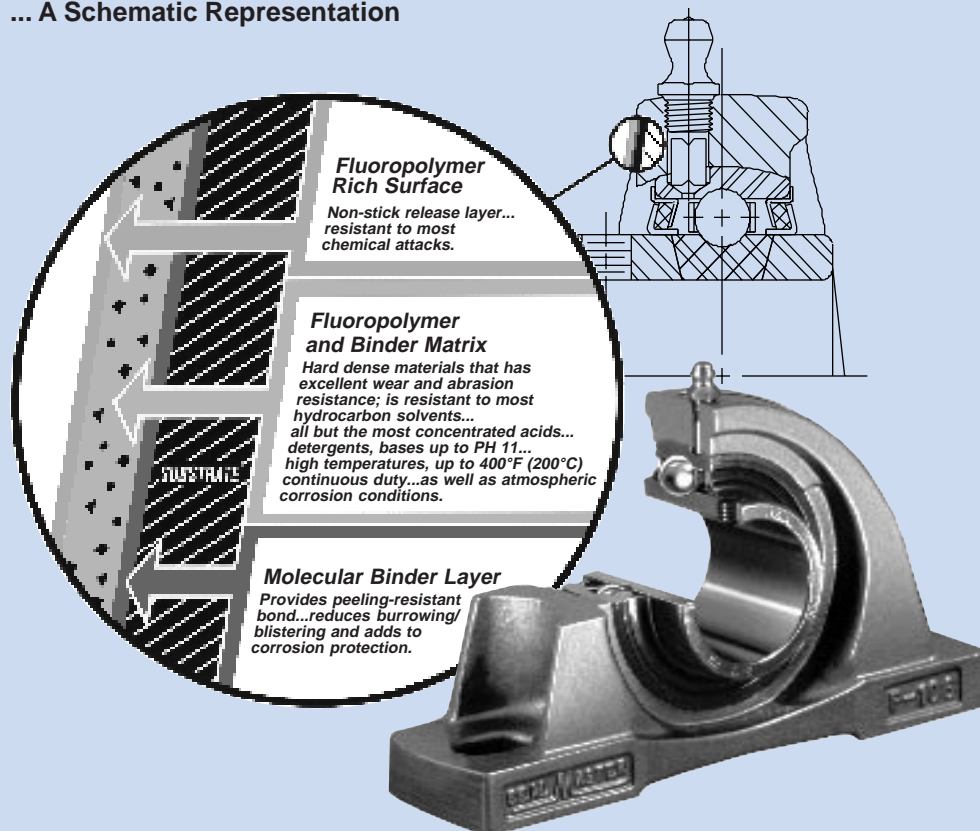

**Fluoropolymer Rich Surface**  
Non-stick release layer... resistant to most chemical attacks.

**Fluoropolymer and Binder Matrix**  
Hard dense materials that has excellent wear and abrasion resistance; is resistant to most hydrocarbon solvents... all but the most concentrated acids... detergents, bases up to PH 11... high temperatures, up to 400°F (200°C) continuous duty...as well as atmospheric corrosion conditions.

**Molecular Binder Layer**  
Provides peeling-resistant bond...reduces burrowing/blistering and adds to corrosion protection.

Available In A Variety Of Styles And Sizes

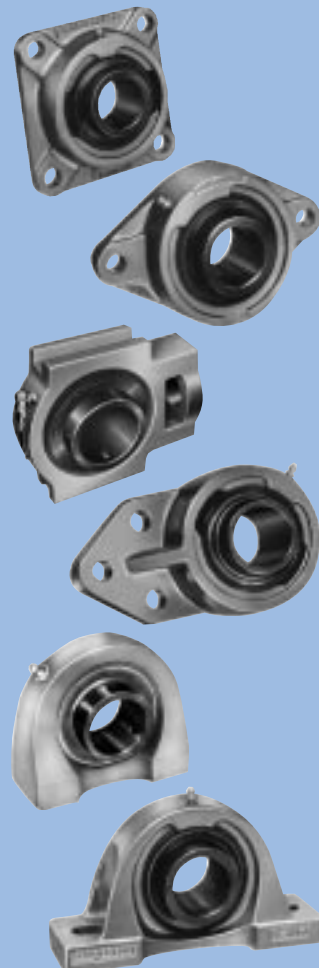

## HOUSING COATING PERFORMANCE CHART

The chart to the right demonstrates the effectiveness of this corrosion-resistant polymer coating for a variety of atmospheric conditions and other physical qualities, against other popular materials. It is also important to note that **SEALMASTER CR Duty Bearings** have the housing bores coated

CORROSION CHARACTERISTICS	SEALMASTER CORROSION DUTY	PAINT	ELECTROLESS NICKEL	CU/NI/CR	NYLON	TEFLON*
ACID	✓✓✓✓	✓	✓✓✓	✓✓	✓✓✓	✓✓✓✓
BASE	✓✓✓✓	✓	✓✓	✓✓	✓✓✓	✓✓✓✓
WASHDOWN	✓✓✓✓	✓	✓✓	✓✓	✓✓✓	✓**
ATMOSPHERIC EXPOSURE	✓✓✓✓	✓✓	✓✓	✓✓	✓✓	✓✓✓✓
NON-STICK	✓✓✓✓	-	-	-	✓	✓✓✓✓
ADHESION TO CASTING	✓✓✓✓	✓✓✓	✓✓✓	✓✓✓	✓✓✓	✓
HARDNESS	✓✓✓	✓✓	✓✓✓✓	✓✓✓✓	✓✓✓	✓
COLOR	✓✓✓✓	✓	✓✓	✓✓✓✓	✓✓	✓✓
EXCELLENT GOOD	4 4 4 4 4 4 4	FAIR POOR	4 4 4	UNACCEPTABLE - **SHOULD NOT BE USED WITH HIGH PRESSURE SPRAYWASH	-	* Teflon is a registered trademark of the Du Pont Company.

For more information on wet environments, see page 136.

For specifications on CR Duty Bearings, see Featured Product Dimension Tables on page 93.



# SEALMASTER® FEATURED PRODUCTS

## THE HIGH TEMPERATURE HF/HFT FURNACE MOUNTED BALL BEARINGS

*Typical applications include:*

- Heat treating equipment
- Kilns, curing furnaces, etc.
- Food processing conveyors (bakeries, etc.)

### High temperature furnace bearings . . . design and application parameters

After extensive research into various market segments and industries, SEALMASTER bearing engineers have developed a new and unique design ball bearing series that is well matched to high temperature applications. To ensure proper selection for severe services, consider these basic application parameters:

1. **What is a “high temperature” bearing?**  
A high temperature bearing is designed to operate in ambient temperatures up to 400°F (200°C). Standard bearings (or slightly modified bearings) are not designed to operate in temperatures above 200°F (100°C).
2. **Where are high temperature bearings typically used?**  
These bearings support conveyor rolls that are designed to transport a variety of materials through industrial furnaces or ovens. Generally, they are operated at slow speeds (up to 800 RPM) with the shaft extending through the heated area. In a rare instance, bearings are located inside the furnace or oven.

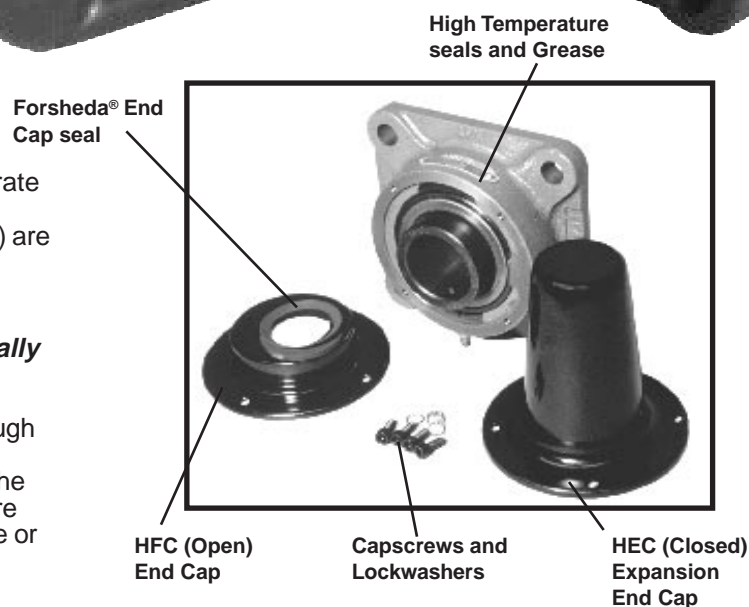
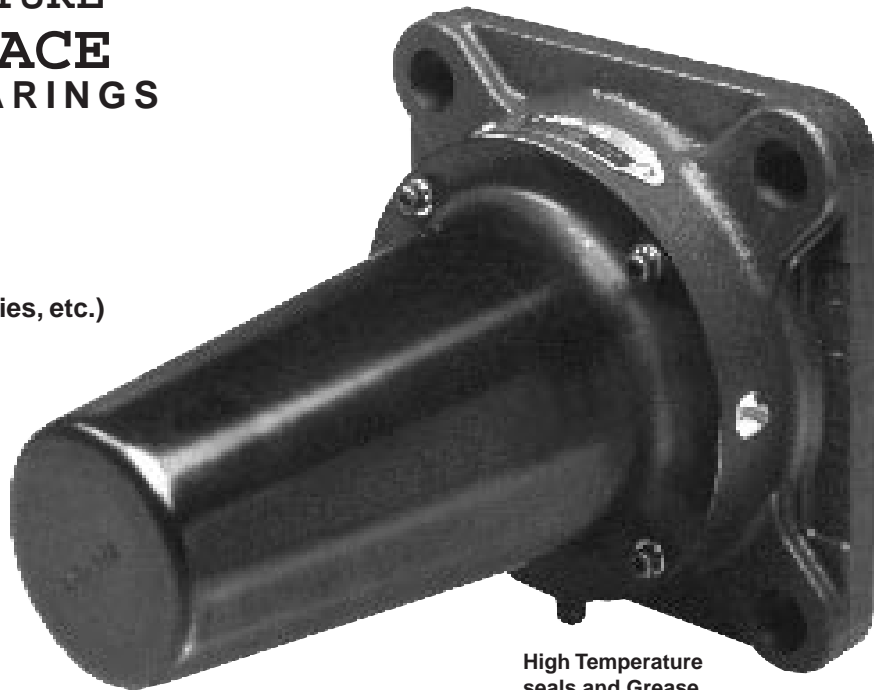

### END CAPS AND AXIAL SHAFT EXPANSION

Sealmaster HF and HFT units can be specified with either HFC or HEC caps. The HFC caps have an opening to allow the shaft to pass through to the customer’s drive system. This cap arrangement normally uses the setscrews supplied in the bearing to lock the bearing to the shaft. The HEC cap is a closed end cap which, when used with the square head setscrew (supplied with cap) and a customer machined keyway in the shaft, allows the shaft to expand through the bore of the bearing when shaft temperature rises. (1) HFC and (1) HEC arrangement is normally recommended on each shaft. **Contact Sealmaster Application Engineering for any question concerning your application.**

### CALCULATING SHAFT GROWTH

Shaft growth (In) = .0000063 x Shaft Length (In) x Change in Temperature (°F.)

### LUBRICATION

Sealmaster HF and HFT bearings are supplied with a high quality/high temperature synthetic lubricant with temperature operating range up to 400°F. The units are equipped with plugs in the lubrication holes in the housing. Bearing life may be extended by addition of fresh lubricant to the unit. Consult Sealmaster Application Engineering for type of lubricant, frequency, and proper procedure for relubrication.

\*Consult Sealmaster Application Engineering before operating outside any limits above.  
Forsheda® is a licensed Trademark of Forsheda Corporation.

# DIFFERENT...BY DESIGN!

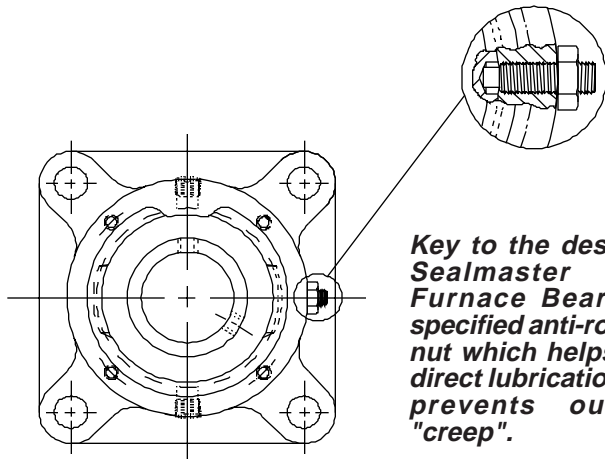

*Key to the design of the Sealmaster HF/HFT Furnace Bearings is a specified anti-rotation lock nut which helps ensure a direct lubrication path and prevents outer race "creep".*

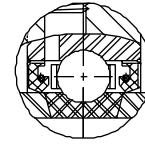

*High Temperature, non-purgable, UltraGard Seals withstand the severe operating environment and help retain lubricant within the bearing chamber.*

## RECOMMENDED LOADS AND SPEEDS

UNIT # 2 BOLT HOUSING	UNIT # 4 BOLT HOUSING	MAX. RECOMMENDED SPEED		MAX. RECOMMENDED LOAD	
		RPM		LBS.	
HFT-16	-	800		150	
HFT-19	-	700		250	
HFT-20R	-	700		250	
HFT-23	HF-23	600		350	
HFT-24	HF-24	500		450	
-	HF-28	500		550	

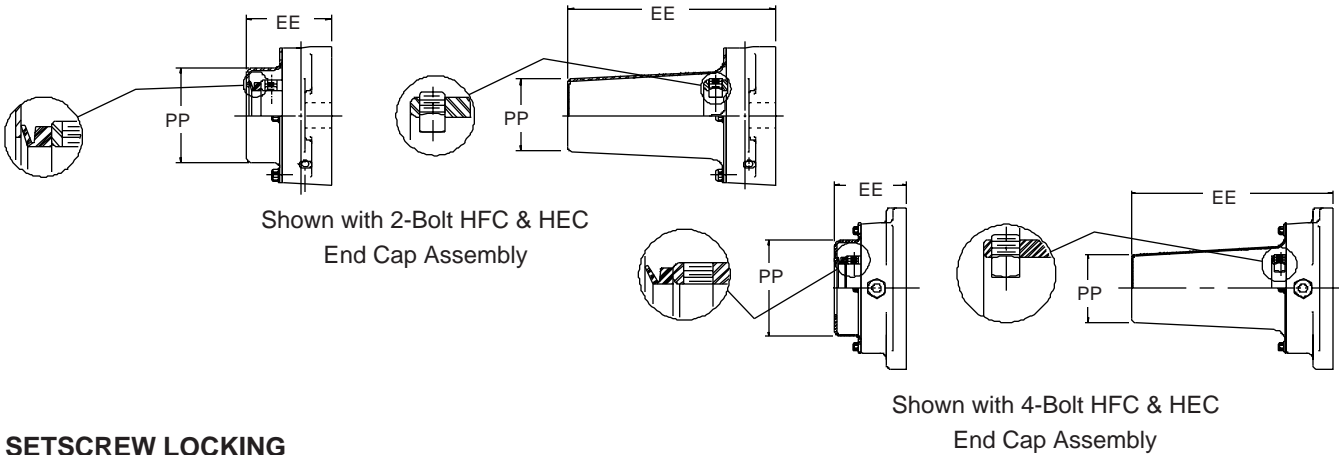

## SETSCREW LOCKING

BORE	TWO BOLT FLANGE	FOUR BOLT FLANGE	2-BOLT END CAPS						4-BOLT END CAPS					
			CAP		HFC		HEC		CAP		HFC		HEC	
			HFC-	EE	PP	HEC-	EE	PP	HFC-	EE	PP	HEC-	EE	EE
1"	HFT-16	-	16	1 23/32	1 29/32	16	4 7/32	1 7/16	-	-	-	-	-	-
1 3/16	HFT-19	-	19	1 27/32	2 3/8	19	4 63/64	1 45/64	-	-	-	-	-	-
1 1/4	HFT-20R	-	20R											
1 7/16	HFT-23	HF-23	23	2 3/64	2 3/4	23	5 23/32	1 31/32	23	2 1/64	2 3/4	23	5 23/32	1 31/32
1 1/2	HFT-24	HF-24	24	2 11/32	2 3/4	24	5 15/32	1 13/16	24	2 5/16	2 3/4	24	5 15/32	1 13/16
1 3/4	-	HF-28	-	-	-	-	-	-	28	2 3/8	2 7/8	28	5 17/32	2 1/16

For specifications on HF/HFT Bearings, see Featured Product Dimension Tables on page 93.  
For more information on High Temperature applications, see page 130.

# SEALMASTER® FEATURED PRODUCT DIMENSIONS

## How to use the Featured Product Dimension Tables...

Sealmaster offers *three* Mounted Ball Bearing featured product lines...

- **The Gold Line Beverage Bearings** explained in more detail on pages 86 & 87.
- **The Gold Line CR Duty Corrosion-Resistant Bearings** explained in more detail on pages 88 & 89.
- **The Gold Line Furnace Bearings** explained in more detail on pages 90-91.

Each may be available in the following bore size:

3/4"	1 1/4"	1 3/4"
1"	1 7/16"	1 15/16"
1 3/16"	1 1/2"	2 3/16"
1 1/4R"	1 11/16"	2 7/16"

## The Availability Column

The availability of each specific product is detailed in the Tables below under *AVAILABILITY*. This column is coded for each featured product line...

- BEV = Beverage Bearing
- CR = CR Duty Corrosion-Resistant
- HF = Four Bolt Furnace Bearing
- HFT = Two Bolt Furnace Bearing

## Beverage Bearing End Caps

BORE SIZE IN INCHES	TWO BOLT END CAPS		FOUR BOLT END CAP	
	OPEN	CLOSED	OPEN	CLOSED
1	TEO-16	TEC-16	FEO-16	FEC-16
1 3/16	TEO-19	TEC-19	FEO-19	FEC-19
1 1/4R	TEO-20R	TEC-19	FEO-20R	FEC-19
1 1/4	TEO-20	TEC-23	FEO-20	FEC-23
1 7/16	TEO-23	TEC-23	FEO-23	FEC-23
1 1/2	TEO-24	TEC-24	FEO-24	FEC-24
1 11/16	TEO-27	TEC-27	FEO-27	FEC-27
1 15/16	TEO-31	TEC-31	FEO-31	FEC-31
2 3/16	TEO-35	TEC-35	FEO-35	FEC-35

## High Base Pillow Blocks... BP, NP-C CR

BORE	AVAILABILITY	A	B	C		H	BOLT SIZE
				MIN	MAX		
3/4	BEV**, CR	1 5/16	5	3 3/8	4 1/8	2 9/16	3/8
1	BEV**, CR	1 7/16	5 1/2	3 7/8	4 3/8	2 13/16	3/8
1 3/16 - 1 1/4R	BEV**, CR	1 11/16	6 1/2	4 7/16	5 1/16	3 3/8	1/2
1 1/4 - 1 7/16	BEV**, CR	1 7/8	6 9/16	4 11/16	5 5/16	3 3/4	1/2
1 1/2	BEV**, CR	1 15/16	7 1/4	4 7/8	5 7/8	3 15/16	1/2
1 11/16	BEV**, CR	2 1/8	7 1/2	5 7/16	6 1/16	4 1/4	1/2
1 15/16	BEV**, CR	2 1/4	8 1/8	6	6 1/2	4 9/16	5/8
2 3/16	BEV**, CR	2 1/2	8 5/8	6 1/2	7	5	5/8
2 7/16	BEV**, CR	2 3/4	9 1/2	6 7/8	7 5/8	5 9/16	5/8

## Low Base Pillow Blocks... BPL, NPL-C CR

BORE	AVAILABILITY	A	B	C		H	BOLT SIZE
				MIN	MAX		
3/4	BEV**, CR	1 1/4	5	3 3/8	4 1/8	2 1/2	3/8
1	BEV**, CR	1 5/16	5 1/2	3 7/8	4 3/8	2 11/16	3/8
1 3/16 - 1 1/4R	BEV**, CR	1 9/16	6 1/2	4 7/16	5 1/16	3 1/4	1/2
1 1/4 - 1 7/16	BEV**, CR	1 13/16	6 9/16	4 11/16	5 5/16	3 11/16	1/2
1 1/2	BEV**, CR	1 15/16	7 1/4	4 7/8	5 7/8	3 15/16	1/2
1 11/16	BEV**, CR	2 1/16	7 1/2	5 7/16	6 1/16	4 3/16	1/2
1 15/16	BEV**, CR	2 3/16	8 1/8	6	6 1/2	4 1/2	5/8
2 3/16	BEV**, CR	2 7/16	8 5/8	6 1/2	7	4 15/16	5/8
2 7/16	BEV**, CR	2 11/16	9 1/2	6 7/8	7 5/8	5 1/2	5/8

## Tapped Base Pillow Blocks... BTB, TB-C CR

BORE	AVAILABILITY	A	B	C	H	THREAD SIZE
3/4	BEV**, CR	1 5/16	3 1/8	2	2 9/16	3/8-16UNC
1	BEV**, CR	1 7/16	3	2	2 13/16	3/8-16UNC
1 3/16 - 1 1/4R	BEV**, CR	1 11/16	4	3	3 13/32	7/16-14UNC
1 1/4 - 1 7/16	BEV**, CR	1 7/8	4 1/4	3 1/4	3 3/4	1/2-13UNC
1 1/2	BEV**, CR	1 15/16	4 5/8	3 1/2	3 15/16	1/2-13UNC
1 11/16	BEV**, CR	2 1/8	5	3 3/4	4 1/4	1/2-13UNC
1 15/16	BEV**, CR	2 1/4	5 1/2	4	4 9/16	5/8-11UNC

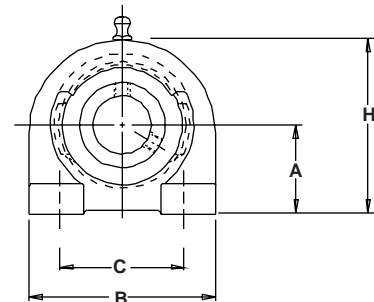
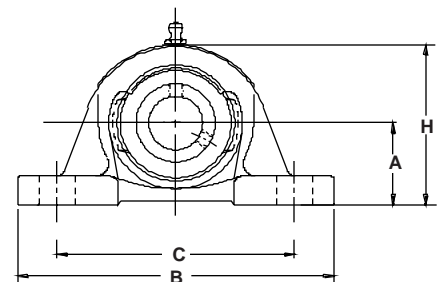

\*\* No End Caps Available

# DIFFERENT...BY DESIGN!

**NOW AVAILABLE  
TAKE-UP UNITS  
FOR BEVERAGE & CR DUTY**

## Specifying Product

Each featured product has unique nomenclature to specify housing and size.

Nomenclature is formatted as follows:

Type Of Bearing	Housing	Bore Size
BEVERAGE BEARINGS	BP	12 = 3/4"
	BPL	16 = 1"
	BTB	19 = 1 3/16"
	BF	20R = 1 1/4R"
	BFT	20 = 1 1/4"
	BFB	23 = 1 7/16"
CR DUTY* BEARINGS	NP	24 = 1 1/2"
	NPL	27 = 1 11/16"
	TB	28 = 1 3/4"
	SF	31 = 2 3/16"
	SFT	35 = 2 3/16"
	FB	39 = 2 7/16"
FURNACE BEARINGS	HF	
	HFT	

## All Beverage Bearings...

Begin With The Letter "B"...

BP-23                  BPL-28  
BTB-20R              BF-12  
BFT-23                BFB-27

## CR Duty Bearings...

Must add "C CR" to all  
CR Duty Bearings...

NP-16C CR  
SF-28C CR  
FB-39C CR

## All Furnace Bearings

Begin With The Letter "H"...

HF-23                  HFT-24

For more Dimensions... Use Standard Duty Gold Line Dimension Tables

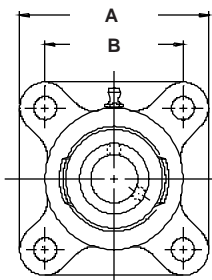

### Four Bolt Flanges... BF, SF-C CR, HF

BORE	AVAILABILITY	A	B	BOLT SIZE
3/4	BEV**, CR	3 3/8	2 1/2	3/8
1	BEV, CR	3 3/4	2 3/4	3/8
1 3/16 - 1 1/4R	BEV, CR	4 1/4	3 1/4	3/8
1 1/4 - 1 7/16	BEV, CR, HF-23	4 5/8	3 5/8	1/2
1 1/2	BEV, CR, HF-24	5 1/8	4	1/2
1 11/16 - 1 3/4	BEV, CR, HF-28	5 3/8	4 1/8	1/2
1 15/16	BEV, CR	5 5/8	4 3/8	9/16
2 3/16	BEV, CR	6 3/8	5 1/8	5/8
2 7/16	BEV**, CR	6 7/8	5 5/8	5/8

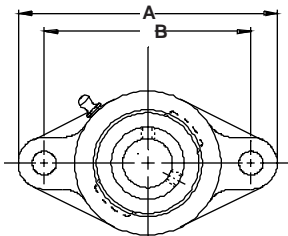

### Two Bolt Flanges... BFT, SFT-C CR, HFT

BORE	AVAILABILITY	A	B	BOLT SIZE
3/4	BEV**, CR	4 13/32	3 17/32	3/8
1	BEV, CR, HFT-16	4 7/8	3 57/64	3/8
1 3/16 - 1 1/4R	BEV, CR, HFT-19, HFT-20R	5 9/16	4 19/32	3/8
1 1/4 - 1 7/16	BEV, CR, HFT-23	6 1/8	5 1/8	1/2
1 1/2	BEV, CR, HFT-24	6 3/4	5 21/32	1/2
1 11/16	BEV, CR	7 1/16	5 27/32	1/2
1 15/16	BEV, CR	7 7/16	6 3/16	9/16
2 3/16	BEV, CR	8 1/2	7 1/4	5/8

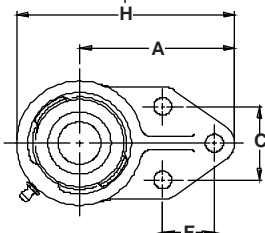

### Three Bolt Flange Brackets... BFB, FB-C CR

BORE	AVAILABILITY	A	C	F	H	BOLT SIZE
3/4	BEV**, CR	3	1 1/2	7/8	4 1/4	3/8
1	BEV**, CR	3 3/8	1 5/8	1 1/8	4 3/4	3/8
1 3/16 - 1 1/4R	BEV**, CR	3 3/4	1 7/8	1 1/4	5 3/8	3/8
1 1/4 - 1 7/16	BEV**, CR	4 1/4	2	1 1/4	6 1/8	1/2
1 15/16	BEV**, CR	5 3/16	2 3/4	1 5/8	7 1/2	1/2

\*\* No End Caps Available

# SEALMASTER®

MOUNTED ROLLER  
BEARINGS...

**TOUGH**  
*AS THEY COME!*

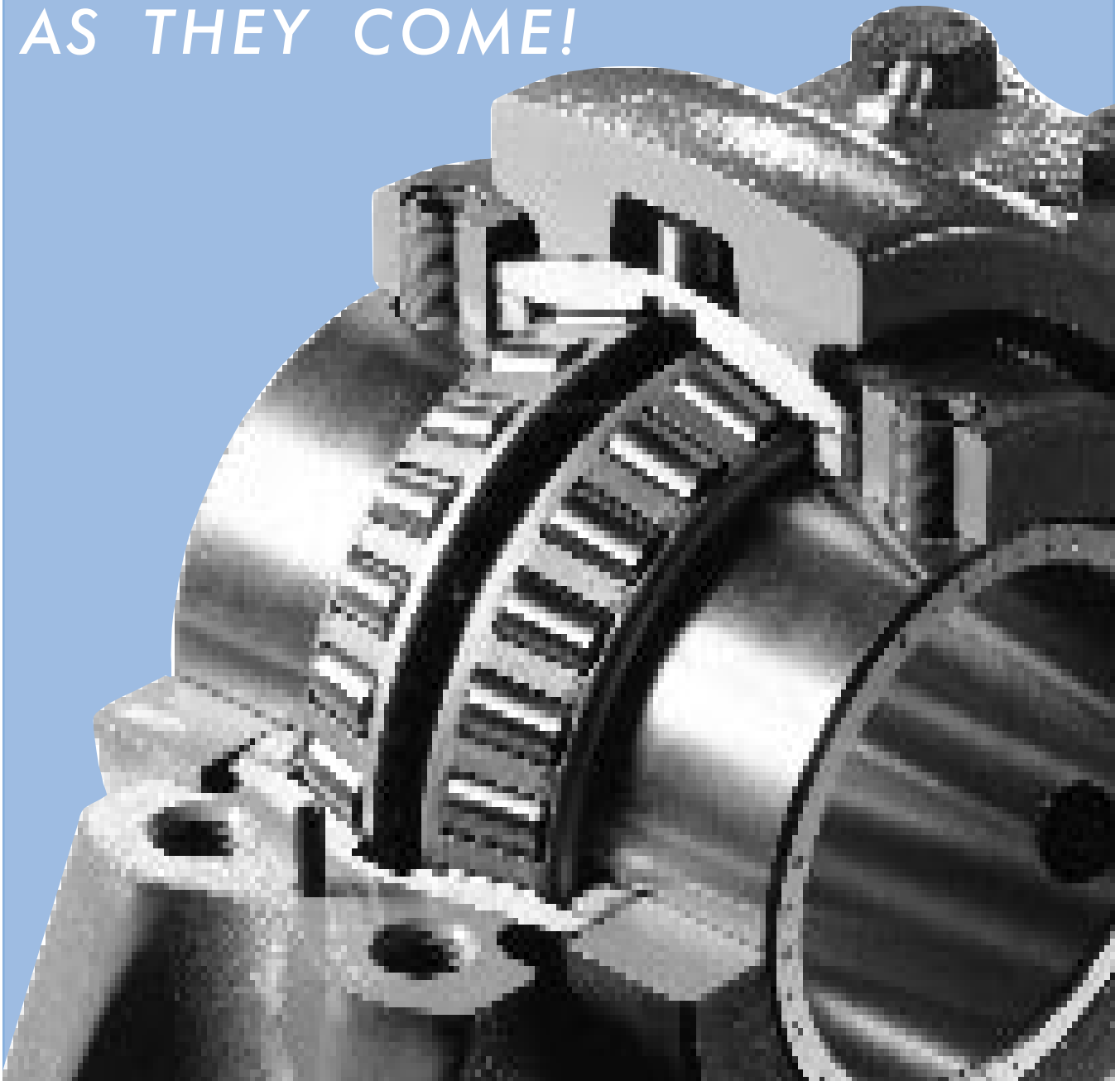









# TABLE OF CONTENTS













	Page Number
<b>Pictorial Index</b> .....	96-97
<b>RPB Series Bearings - Features and Benefits</b> .....	98-103
<b>RPB Series - Specifications and Dimensions - Pillow Blocks</b> .....	104-106
RPB Series, Two-Bolt Pillow Blocks .....	104
RPB Series, Four-Bolt Pillow Blocks .....	104
RPB-A Series, Two-Bolt Pillow Blocks .....	105
RPB-A Series, Four-Bolt Pillow Blocks .....	105
ERPB Series, Expansion Two-Bolt Pillow Blocks .....	106
ERPB Series, Expansion Four-Bolt Pillow Blocks .....	106
<b>DRPB Series - Specifications and Dimensions - Pillow Blocks</b> .....	107-109
DRPB Series, Two-Bolt Pillow Blocks .....	107
DRPB Series, Four-Bolt Pillow Blocks .....	107
DRPBA Series, Two-Bolt Pillow Blocks .....	108
DRPBA Series, Four-Bolt Pillow Blocks .....	108
EDPB-A Series, Expansion Two-Bolt Pillow Blocks .....	109
EDPB-A Series, Expansion Four-Bolt Pillow Blocks .....	109
<b>RPBXT Series - Features and Benefits</b> .....	110
<b>RPBXT Series - Specifications and Dimensions</b> .....	111
RPBXT Series, Four-Bolt Pillow Blocks .....	111
ERPBXT Series, Expansion Four-Bolt Pillow Blocks .....	111
<b>SPB Series - Specifications and Dimensions (Steel Housing)</b> .....	112
SPB Series, Two-Bolt Pillow Blocks (Steel Housing) .....	112
SPB Series, Four-Bolt Pillow Blocks (Steel Housing) .....	112
<b>RFB, RFP Series Flange Units - Specifications and Dimensions</b> ..	114-117
RFB Series Flange Units - Four Bolts .....	114
RFB-A Series Flange Units - Four Bolts .....	115
RFP Series Piloted Flange Units - Four Bolts .....	116
RFP-A Series Piloted Flange Units - Four Bolts .....	117
<b>RPB Series Cartridge Inserts - Specifications and Dimensions</b> ..	118-120
ERCI Series Cylindrical Cartridge Inserts .....	118-119
RCI and RCI-A Cartridge Inserts (One & Two Locking Collars) .....	120
<b>Custom Design RPB Series Roller Bearings</b> .....	122-127
RPB-CR Corrosion Resistant .....	122-123
RPB-AH Series - Air Handling .....	124-125
RPB-M Metric Bore .....	126-127
<b>Application Problem Solvers</b> .....	129-143

# SEALMASTER® MOUNTED ROLLER BEARINGS

SERIES	Bearing Configuration	Fixed Type	Expansion Type	Housing Material	Mounting Base	Setscrew Locking Collar	Available Bore Sizes (Inches)	Other Important Features	Selection Factors	Application Information
 <b>RPB</b> Features & Benefits See Pages 98-103 <b>Dimensional Data Page 104</b>	Pillow Block	x		Cast Iron	Standard Two and Four Bolt; Elongated Bolt Holes	Double	1 <sup>3</sup> / <sub>16</sub> - 5	The basic RPB-Series Bearing, Used in the widest range of applications; choice of <i>three</i> sealing arrangements as shown.		
 <b>RPB-A</b> Features & Benefits See Pages 98-103 <b>Dimensional Data Page 105</b>	Pillow Block	x		Cast Iron	Standard Two and Four Bolt; Elongated Bolt Holes	Single	1 <sup>3</sup> / <sub>16</sub> - 5	Particularly recommended where space is limited; fewer sizes; choice of three basic sealing arrangements.		
 <b>ERPBB</b> Features & Benefits See Pages 98-103 <b>Dimensional Data Page 106</b>	"Floating" Pillow Block-Expansion Type		x	Cast Iron	Two and Four Bolt; <i>Matches</i> the Mounting Dim. of RPB, RPB-A	Double	1 <sup>3</sup> / <sub>4</sub> - 5	Generally used in conjunction with RPB/RPB-A Series units where a "floating" or expansion pillow block is required.		
 <b>RPBXT</b> Features & Benefits See Page 110 <b>Dimensional Data Page 111</b> And ERPB-XT	Pillow Block (Non-Expansion and Expansion Type)	x	x	Cast Iron	Four Bolt Only; Elongated Bolt Holes	Double	2 <sup>1</sup> / <sub>4</sub> - 5	Interchanges base to centerline and bolt hole spacing with 500 Series SAF style spherical roller bearing pillow blocks.		
 <b>DRPB</b> Features & Benefits See Pages 98-103 <b>Dimensional Data Page 107</b>	Pillow Block- <i>High Base</i> to Shaft $\varnothing$ Mounting	x		Cast Iron	<i>Wide Base</i> , Two and Four Bolt Designs	Double	1 <sup>3</sup> / <sub>4</sub> - 4	<i>Dimensionally interchangeable with competitive "DI" types</i> ; bearing load and speed capabilities equal to RPB.		
 <b>DRPB-A</b> Features & Benefits See Pages 98-103 <b>Dimensional Data Page 108</b>	Pillow Block- <i>High Base</i> to Shaft $\varnothing$ Mounting	x		Cast Iron	<i>Wide Base</i> , Two and Four Bolt Designs	Single	1 <sup>3</sup> / <sub>4</sub> - 4	<i>Dimensionally interchangeable with competitive "K" types</i> ; bearing load and speed capabilities equal to RPB.		
 <b>EDPB-A</b> Features & Benefits See Pages 98-103 <b>Dimensional Data Page 109</b>	"Floating" Pillow Block Expansion Type		x	Cast Iron	Two and Four Bolt <i>Expansion</i> , High Base Type	Single	1 <sup>3</sup> / <sub>4</sub> - 4	Expansion type with high base-to-shaft centerline mounting dimensions; interchangeable with competitors "K" Series.		
 <b>SPB</b> Features & Benefits See Pages 98-103 <b>Dimensional Data Page 112</b>	Pillow Block	x		Cast Steel	Two Bolt	Double	1 <sup>1</sup> / <sub>2</sub> - 3 <sup>1</sup> / <sub>2</sub>	Steel housings meet SAE J43T specifications, 65,000 psi. Choice of three sealing arrangements.		

# TYPE, SIZES, AVAILABILITY, SELECTION FACTORS

SERIES	Bearing Configuration	Fixed Type	Expansion Type	Housing Material	Mounting Base	Setscrew Locking Collar	Available Bore Sizes (Inches)	Other Important Features	Selection Factors	Application Information
 <b>SPB</b> Features & Benefits See Pages 98-103 Dimensional Data Page 112	Pillow Block	x		Cast Steel	Four Bolt	Double	3 <sup>15</sup> / <sub>16</sub> – 5	Steel Housings meet SAE J43T specifications, 65,000 psi. Choice of three sealing arrangements.		
 <b>RFB</b> Dimensional Data Page 114	Flange Units	x		Cast Iron	Standard Four Bolt	Double	1 <sup>3</sup> / <sub>16</sub> – 4 1/2	Designed for industrial machinery where heavy loads at low, medium or relatively high speeds exist; vertical or horizontal face mounting.		
 <b>RFB-A</b> Dimensional Data Page 115	Flange Units	x		Cast Iron	Standard Four Bolt	Single	1 <sup>3</sup> / <sub>16</sub> – 4 1/2	For moderate loads at low to medium high speeds exist, or where space along the shaft is at a premium.		
 <b>RFP</b> Dimensional Data Page 116	Piloted Flange Units	x		Cast Iron	Standard Four Bolt	Double	1 <sup>3</sup> / <sub>16</sub> – 5	Designed for applications where heavy loads at low, medium or relatively high speeds exist.		
 <b>RFP-A</b> Dimensional Data Page 117	Piloted Flange Units	x		Cast Iron	Standard Four Bolt	Single	1 <sup>3</sup> / <sub>16</sub> – 5	Designed for applications where moderate loads at low to medium high speeds exist.		
 <b>ERCI</b> Dimensional Data Pages 118 & 119	Cylindrical Cartridge Inserts (For ERPB)		x			Double	1 <sup>3</sup> / <sub>4</sub> – 5	Designed to mount directly in customer housings, or as replacement insert for RPB-Expansion Type Bearings.		
 <b>RCI</b> <b>RCI-A</b> Dimensional Data Page 120	Replaceable Cartridge Inserts (Two Types)	x				Double Single	1 <sup>3</sup> / <sub>16</sub> – 5	Applicable to ALL fixed type RPB-Series Bearings in this group.		
 <b>RPB-CR</b> Corrosion Resistant Features & Benefits Pages 122-123	*Available in All Standard Bearing Styles	x	x	Cast Iron	All Housing Styles	Single Double	1 <sup>3</sup> / <sub>16</sub> – 5	Designed especially for applications where the bearings may be subjected to moisture corrosive and abrasive environments.		
 <b>RPB-AH</b> Air Handling Features & Benefits See Pages 98-103,124 Dimensional Data Pages 125	*Available in Pillow Blocks, Flange Units Piloted Flange Units	x	x Available	Cast Iron	Standard Two and Four Bolt Pillow Blocks*	Double	1 <sup>3</sup> / <sub>16</sub> – 5	Designed especially for air handling applications in the HVAC... higher speeds some vibration, low noise levels.		
 <b>RPB-M</b> Metric Features & Benefits See Pages 98-103,126 Dimensional Data Pages 127	*Available in ALL-Standard Bearing Styles	x	x Available	Cast Iron	Standard Two and Four Bolt Pillow Blocks*	Double	(35-125mm)	Available in RPB-Series with split housing.		



# SEALMASTER® MOUNTED ROLLER BEARINGS

## Check Out the Industry's Only Tapered Roller Bearing Units in This Compact Size Range... With Unitized, Self-Aligning Replaceable Cartridge Inserts.

SEALMASTER RPB Series mounted roller bearings 'MASTER' the toughest application conditions, handling combination radial and thrust loads in a broad range of severe duty services. *And they keep on going!*

For more than 20 years, RPB Series bearings have been put to the ultimate tests in a variety of tough services and most demanding environments. They've demonstrated exceptional service life in problem applications from aggregates to chemical processing... in sawmills and pulp and paper mills, etc... where they've *kept on rolling when other bearings failed.*

### Toughness By Design

These premium heavy-duty bearing units offer outstanding design features that rapidly equate to money-saving benefits... like significantly increased overall reliability, substantially longer operating life, reduced maintenance, replacement and downtime... even under the toughest and most demanding conditions.

### More Sizes, More Configurations Mean More Choices

Select from two and four-bolt pillow blocks in bore sizes from 1 3/16" - 5", flange units from 1 3/16" - 4 1/2", piloted flange units and "one-size-fits-all" cartridge inserts in the full range of bore sizes, 1 3/16" - 5". All are available for quick shipment from stock.

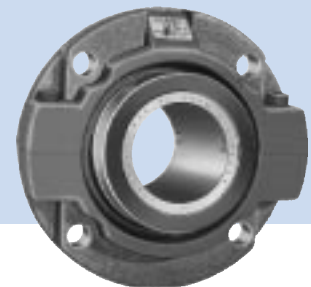
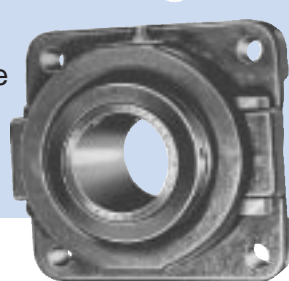
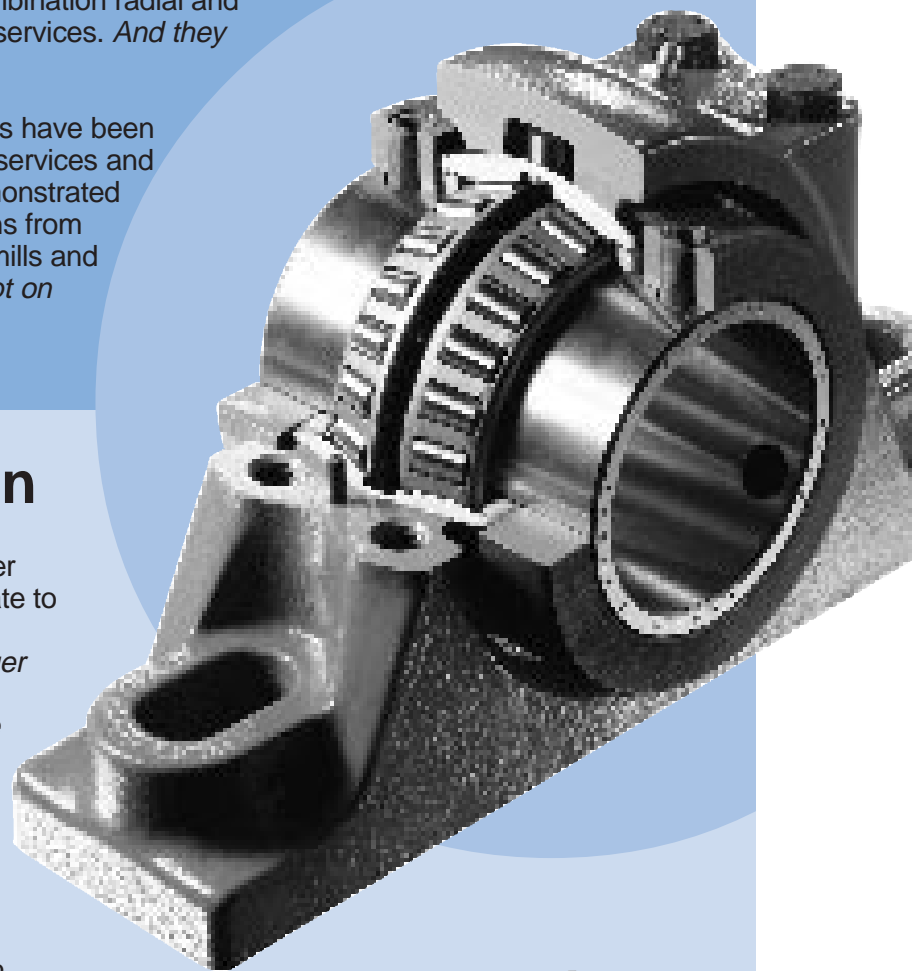

# TOUGH AS THEY COME!

## DURABLE CAST IRON SPLIT HOUSINGS

The user's major cost is not always the original cost of the bearing, but the installation time required to put it into productive operation. RPB cast iron split housings have a ribbed design for added strength. Cap bolts are Grade 5 minimum width 60,000 psi tensile strength.

- Quickest replacement of bearing insert whenever change out is needed.
- Once installed, the housing base *always* remains aligned with the shaft... doesn't need to be disturbed.
- Reduce downtime, replacement costs.
- Guide pins in the housing base and mating holes in the cap help eliminate error during replacement. Guide pins *ensure* the proper orientation of the top housing - *in the same direction in which it was machined at the factory* - for optimum fitup and assembly.

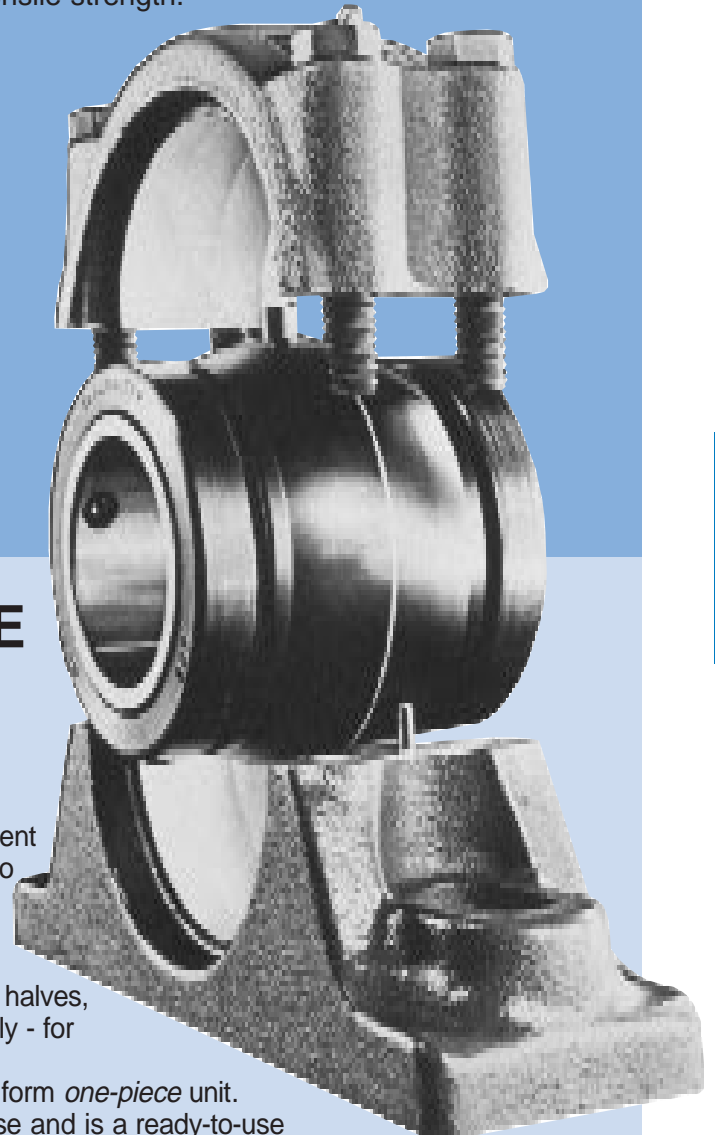

## UNITIZED REPLACEABLE CARTRIDGE INSERTS

The heart of the RPB Series bearing is the one-piece, self-aligning cartridge with integral seals and double locking collars. This represents a significant achievement in engineering and manufacture. Each cartridge fits into *any* RPB housing style for maximum control of inventory and easy replacement.

- Constructed from two precision ground outer race halves, *matched* to a Timken® bearing inner race assembly - for optimum end play control.
- Outer race halves are then carefully processed to form *one-piece* unit.
- The cartridge unit is sealed and packed with grease and is a ready-to-use self-contained insert - for assembly in SEALMASTER housings or as field replacement bearings.
- Optimum factory-controlled end play eliminates use of shims, snap rings, machined shoulders and lock nuts, ensures proper roller contact with the races reducing edge loading, eliminates field adjustment problems found with other designs.

**UNIQUE...UNCHALLENGED...THE UNDISPUTED LEADER  
IN QUALITY AND VALUE-ADDED ADVANTAGES**

# SEALMASTER® MOUNTED ROLLER BEARINGS

## **TIMKEN® TAPERED ROLLER BEARINGS**

*Offer rugged design, proven performance and outstanding reliability in a diversity of heavy-duty applications...*

- Inner race, rollers and cage assemblies manufactured by Timken®, with over 80 years' experience in this type of bearing.. tapered rollers provide true rolling motion with minimum friction.
- Inner race and rollers of case-hardened, alloy steel - provide long fatigue life under heavy loads.
- Ensures optimum performance under combined radial and thrust loads. Can carry high thrust loads where spherical bearings in the same type of application may be limited.

## **ONE-PIECE SPHERICAL OUTER RACE**

- Manufactured from through-hardened 52100 steel with a spherical outside diameter; black oxide treated for corrosion protection.
- Precision fit with the spherical seat in the housing... provides even load distribution, allows full 3° static misalignment capability - more than twice the capability of most other spherical bearings - the 3° self-aligning feature reduces abnormal stress on bearing components and seals...overcomes alignment problems common in rigid type tapered roller bearings with one-piece housings.

## **ALIGNMENT PIN**

- Inserted between the mating outer race halves - fits into a recess in the housing top.
- Ensures positive lubrication - one of two cartridge lubrication openings always lines up with the grease fitting.
- Prevents outer race rotation of the cartridge insert; the hardened steel outer race cannot rotate in the housing under load, thus keeping intact the factory-adjusted fit between the housing and cartridge... the race will not wear away the cast iron housing because it is locked in place.

## **POSITIVE LUBRICATION SYSTEM**

*Lubrication doesn't have to travel around an annular grease groove - it follows a short path directly into the bearing!*

- Cartridge contains two lubrication ports and one relief port... extra lube ports prevent seal damage by venting excess pressure from overgreasing.
- Rubber grommet is located in the housing cavity beneath the grease fitting - lines up with one of the lube ports in the cartridge to direct the grease into the bearing... competitive spherical roller bearings with one-piece outer races are designed with a circumferential grease groove and oil hole to direct grease into the bearing; soap base greases (conforming to NLGI grade #2) can dry out, cake and harden if the bearing is stored for long periods of time or not lubricated frequently. This can obstruct clean grease from entering the bearing and possibly lead to a premature bearing failure.
- The cartridge is designed for universal assembly into any RPB housing style... can be a major cost-saver where many bearings are used.

## **PATENTED FELT LABYRINTH RACE MOUNTED SEALS**

*Direct contaminants away from the sealing surfaces... provide a tight fit to exclude foreign material... have less drag and less heat generation than radial lip rubber contact seals.*

- Same proven design used in SEALMASTER Gold Line Ball Bearings.
- Outer shield rotates with the shaft, creating a flinger action which reduces contaminant build-up. Outer flinger-shield extends slightly into bearing chamber to churn and break up the grease flow and direct it back into the rolling elements.
- Effective sealing in dry, dusty or dirty environments - felt acts as a filter, has low friction.
- Race mounted seals are not subject to misalignment distortion.
- Shields are black oxide treated for corrosion protection.

# TOUGH AS THEY COME!

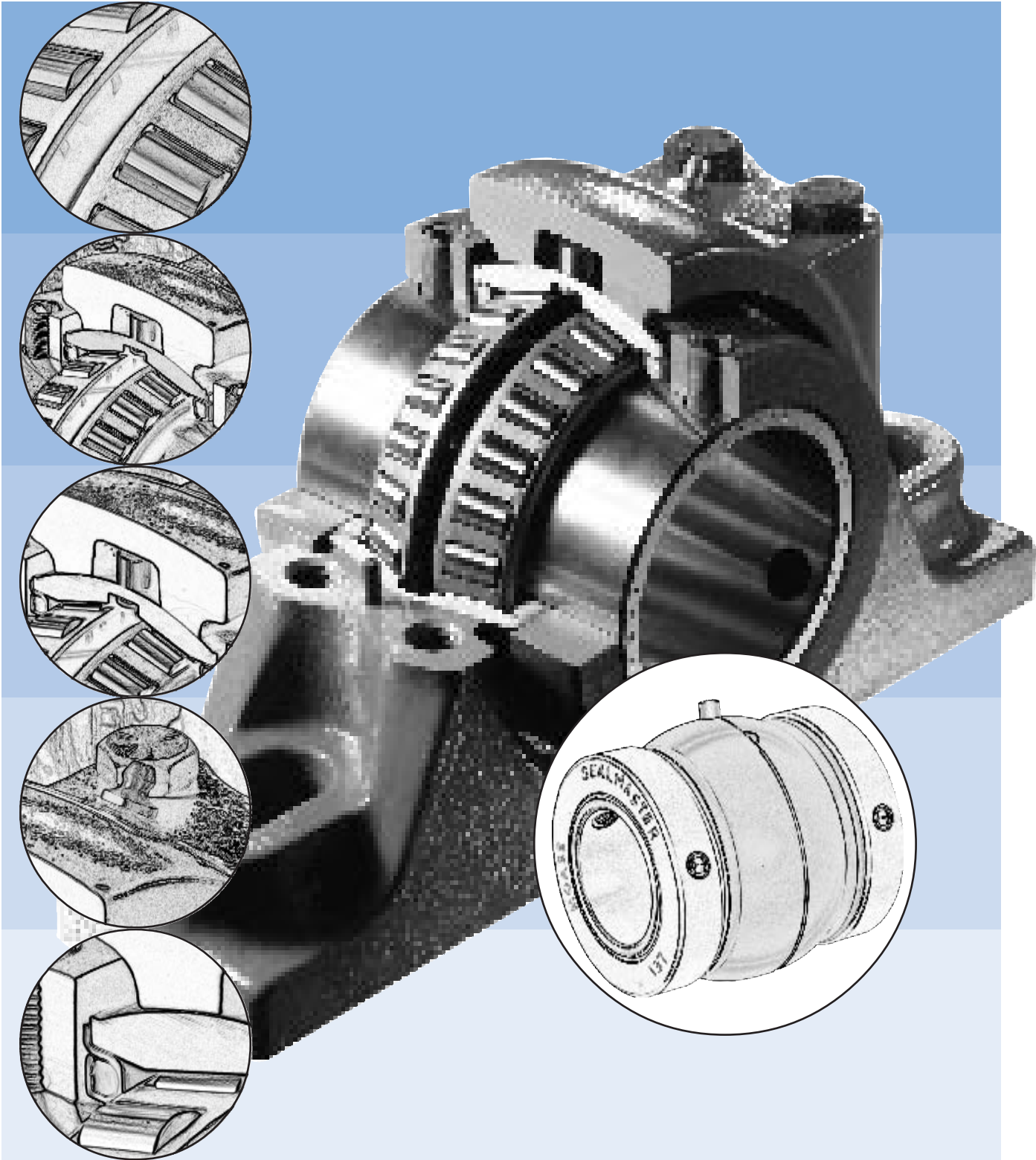

**UNIQUE...UNCHALLENGED...THE UNDISPUTED LEADER  
IN QUALITY AND VALUE-ADDED ADVANTAGES**

# SEALMASTER® MOUNTED ROLLER BEARINGS

## SINGLE LIP RACE MOUNTED CONTACT SEALS

Available on all bearing sizes recommended where moisture conditions prevail...

- Consists of an elastomeric rubber sealing element bonded to a steel shield.
- Functions well in wet and dirty environments up to 250° F.
- Has good chemical resistance properties.
- Race mounted seals are not subject to misalignment distortion.
- Shields are black oxide treated for corrosion protection.

## CONCENTRIC DOUBLE LOCKING COLLARS

The RPB locking system has **MORE HOLDING POWER** compared to spherical roller bearings with one lock collar (4 setscrews instead of 2)

- Each collar has 2 setscrews spaced at 120° - provides balanced three-point contact and symmetrical locking.
- Hardened setscrews in a soft collar provide maximum holding power in applications involving heavy loads, reversing and vibration... a special coating on the setscrews reduces the friction when inserting and torquing them into the lock collars, resulting in more holding power.
- Double extended inner races provide excellent shaft support - load is distributed evenly over a wide area.
- Collars also serve as 2 extra flingers that rotate with the shaft to repel contaminants away from the seal.
- Black oxide treated for added corrosion protection.

## OTHER FEATURES AND OPTIONS

### 1. SINGLE LOCKING COLLARS

Generally for applications involving shaft length considerations or limited space.

- Available from stock in bore sizes, 1 3/4" - 3 15/16".
- Designated with "A" suffix, e.g. RPBA207-2... see pages 105, 108, 109, 115, 117, and 120.

### 2. CYLINDRICAL CARTRIDGE INSERTS

Designed to mount directly into customer housings and as inserts in expansion RPB housings.

- Available from stock in 1 3/4" - 5" bore sizes with felt and contact seals.
- High temperature grease and seals can be supplied on request.

### 3. EXPANSION TWO AND FOUR BOLT PILLow BLOCKS

- Available from stock in bore sizes 1 3/4" - 5".
- Total expansion 3/16" - 3/8"... see pages 106, 109 and 111.

### 4. CAST STEEL PILLow BLOCKS

For applications requiring greater housing strength than cast iron.

- Two bolt bases - bore sizes 1 1/2" - 3 1/2"... see page 112.
- Four bolt bases - bore sizes 3 15/16" - 5"... see page 112.

### 5. INDUSTRY INTERCHANGEABILITY

- Same bolt centers and base-to-shaft centerline as most competitive one-piece housings. (Metal nameplate attached securely beneath the grease fitting for long-lasting identification.)
- Longer bolt slots permit easy replacement for most competitive brands.
- New RPBXT Series has interchangeable shaft-to-centerline dimensions and bolt hole spacing with the popular 500 Series SAF style spherical roller bearing pillow blocks... see pages 110 and 111.

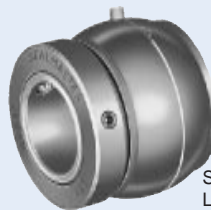

Single Locking Collars

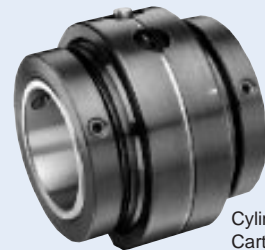

Cylindrical Cartridge Inserts

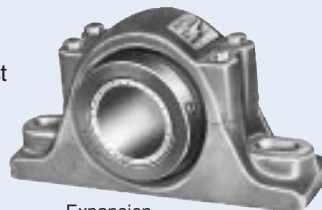

Expansion Two & Four Bolt Pillow Blocks

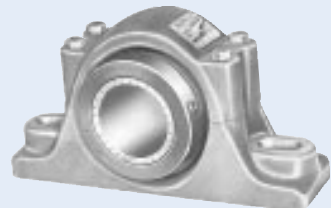

Cast Steel Pillow Blocks

# TOUGH AS THEY COME!

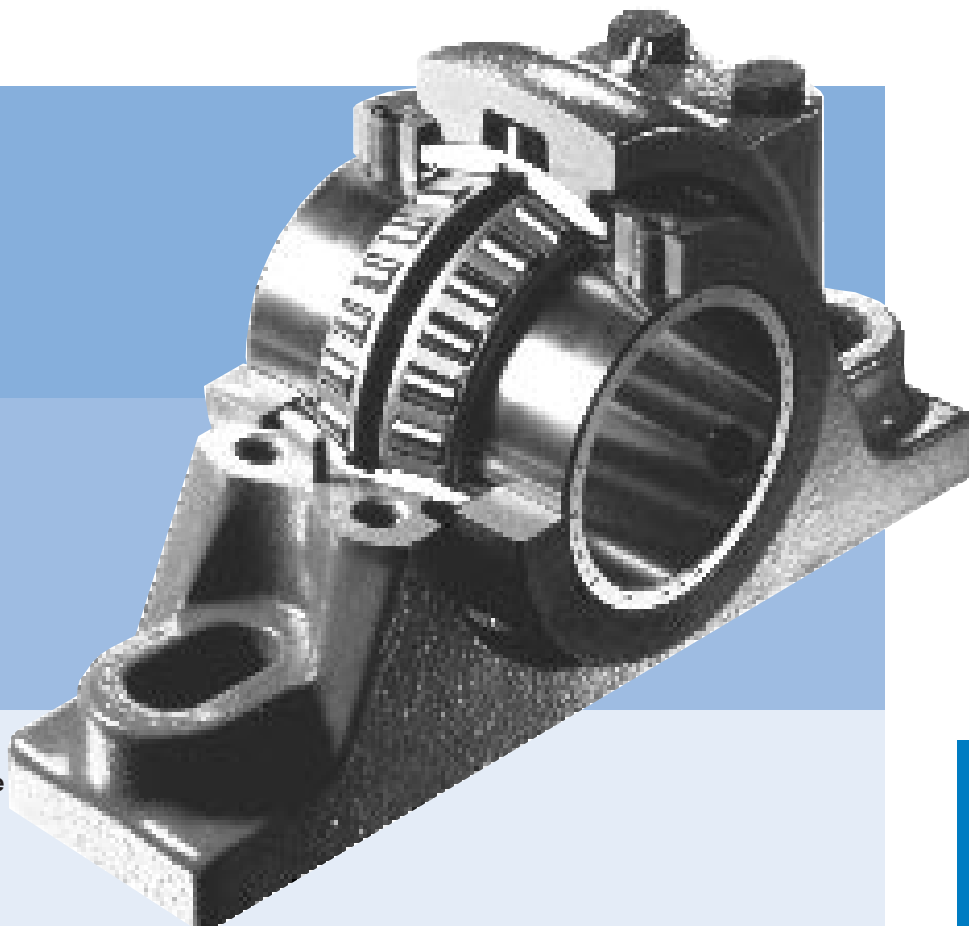
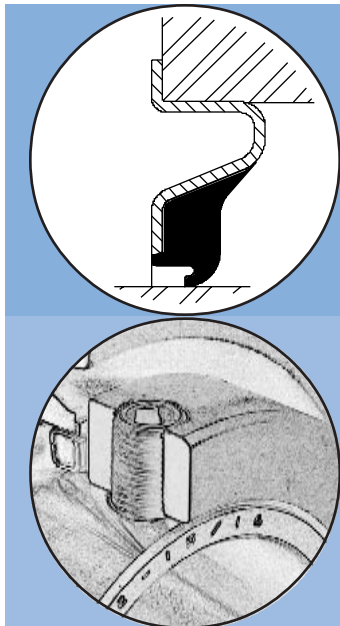

## 6. CUSTOM CAPABILITIES

Versatile RPB Series roller bearings are adaptable to a broad range of custom design features. Price and delivery furnished on request.

Some of these include...

### A: TIGHT HOUSING FITS

- Tight housing fit "TF" for vibrating conveyor applications.

Some applications require a tight fit-up between the bearing cartridge O.D. and the housing. Typical applications of this type are on vibrating conveyors and shaker screens where eccentric and rotating loads exist. The tight fit-up prevents the movement of the cartridge in the housing. The RPB-TF units are shipped from the factory with cap bolts snugged by hand and tagged with the proper torque specifications. It is important to allow the cartridge insert to seat itself properly *before* torquing the capscrews and cap bolts.

See pages 140-141 for Vibratory Application information.

### B: CUSTOM HOUSINGS

Generally require pattern and tooling charges - price and delivery furnished on request.

- Tapped base pillow blocks.
- Housing styles to match competitive base-to-centerline and bolt spacing dimensions.
- Ductile iron or steel.

### C: REDUCED END PLAY

Requires an application review by our engineering department. Ask our Engineers for additional information.

### D: HIGH TEMPERATURE

- High temperature seals and grease - "Nomex" material is used in place of felt where requested for elevated temperature environments...the current high temperature grease standard is Mobile SHC 460.
- Price and delivery of customer lubricants including (OSP) oil saturated polymer can be furnished on request.

**For all tough applications...  
where performance and reliability  
count... specify SEALMASTER  
Self-Aligning RPB Series tapered  
roller bearings.**

Refer to specifications and dimensions on the following pages.

Contact Sealmaster Applications at 630-898-9620.

**UNIQUE...UNCHALLENGED...THE UNDISPUTED LEADER  
IN QUALITY AND VALUE-ADDED ADVANTAGES**

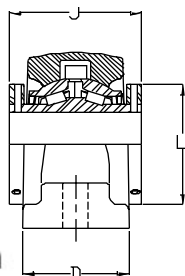

Two Bolt Base

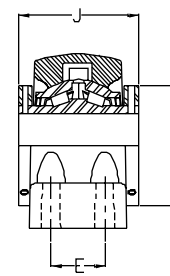
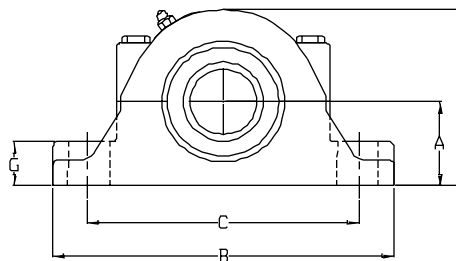

Four Bolt Base

## RPB Series Pillow Blocks...Two Bolt Base

SHAFT DIAM. IN.	STANDARD SEAL PART NO.	CONTACT SEAL PART NO.	HI-TEMP (1) SEAL PART NO.	APPROX. WT. IN LBS.	DIMENSIONS IN INCHES										BASE BOLTS	
					A	B	C		D	E	G	H	J	L	NO.	SIZE
							MIN.	MAX.								
1 3/16 1 1/4	RPB-103-2 RPB-104-2	RPB-103-C2 RPB-104-C2	RPB-103-N2 RPB-104-N2	4.80	1.50	6.25	4.56	4.94	1.88	—	.88	3.12	2.75	2.25	2	1/2
1 3/8 1 7/16	RPB-106-2 RPB-107-2	RPB-106-C2 RPB-107-C2	RPB-106-N2 RPB-107-N2	7.7	1.88	7.25	5.31	5.94	2.06	—	1.12	3.81	3.00	2.62	2	1/2
1 1/2 1 5/8 1 11/16	RPB-108-2 RPB-110-2 RPB-111-2	RPB-108-C2 RPB-110-C2 RPB-111-C2	RPB-108-N2 RPB-110-N2 RPB-111-N2	10.9	2.12	7.75	5.56	6.44	2.31	—	1.25	4.38	3.38	2.88	2	1/2
1 3/4 1 15/16 2	RPB-112-2 RPB-115-2 RPB-200-2	RPB-112-C2 RPB-115-C2 RPB-200-C2	RPB-112-N2 RPB-115-N2 RPB-200-N2	13.2	2.25	8.88	6.31	7.19	2.44	—	1.25	4.62	3.50	3.25	2	5/8
2 3/16	RPB-203-2	RPB-203-C2	RPB-203-N2	15.7	2.50	9.62	6.69	7.94	2.56	—	1.44	5.12	3.75	3.62	2	5/8
2 1/4 2 7/16 2 1/2	RPB-204-2 RPB-207-2 RPB-208-2	RPB-204-C2 RPB-207-C2 RPB-208-C2	RPB-204-N2 RPB-207-N2 RPB-208-N2	20.7	2.75	10.38	6.94	8.69	2.75	—	1.62	5.62	4.00	3.94	2	5/8
2 11/16 2 3/4 2 15/16 3	RPB-211-2 RPB-212-2 RPB-215-2 RPB-300-2	RPB-211-C2 RPB-212-C2 RPB-215-C2 RPB-300-C2	RPB-211-N2 RPB-212-N2 RPB-215-N2 RPB-300-N2	29.3	3.12	11.75	8.06	9.69	3.00	—	1.75	6.38	4.50	4.75	2	3/4
3 3/16 3 7/16 3 1/2	RPB-303-2 RPB-307-2 RPB-308-2	RPB-303-C2 RPB-307-C2 RPB-308-C2	RPB-303-N2 RPB-307-N2 RPB-308-N2	56.0	3.75	13.75	10.12	11.25	4.12	—	2.06	7.75	5.00	5.55	2	7/8

## RPB Series Pillow Blocks...Four Bolt Base

SHAFT DIAM. IN.	STANDARD SEAL PART NO.	CONTACT SEAL PART NO.	HI-TEMP (1) SEAL PART NO.	APPROX. WT. IN LBS.	DIMENSIONS IN INCHES										BASE BOLTS	
					A	B	C		D	E	G	H	J	L	NO.	SIZE
							MIN.	MAX.								
2 1/4 2 7/16 2 1/2	RPB-204-4 RPB-207-4 RPB-208-4	RPB-204-C4 RPB-207-C4 RPB-208-C4	RPB-204-N4 RPB-207-N4 RPB-208-N4	22.4	2.75	10.38	7.75	8.75	3.50	1.88	1.62	5.62	4.00	3.94	4	5/8
2 11/16 2 3/4 2 15/16 3	RPB-211-4 RPB-212-4 RPB-215-4 RPB-300-4	RPB-211-C4 RPB-212-C4 RPB-215-C4 RPB-300-C4	RPB-211-N4 RPB-212-N4 RPB-215-N4 RPB-300-N4	31.5	3.12	11.75	8.75	10.00	3.75	2.12	1.75	6.38	4.50	4.75	4	5/8
3 3/16 3 7/16 3 1/2	RPB-303-4 RPB-307-4 RPB-308-4	RPB-303-C4 RPB-307-C4 RPB-308-C4	RPB-303-N4 RPB-307-N4 RPB-308-N4	59.6	3.75	13.75	10.56	11.50	4.50	2.38	2.06	7.75	5.00	5.55	4	5/8
3 15/16 4	RPB-315-4 RPB-400-4	RPB-315-C4 RPB-400-C4	RPB-315-N4 RPB-400-N4	76.9	4.25	15.25	11.00	13.00	4.50	2.25	2.44	8.62	6.25	6.00	4	5/8
4 7/16 4 1/2	RPB-407-4 RPB-408-4	RPB-407-C4 RPB-408-C4	RPB-407-N4 RPB-408-N4	95.6	4.75	16.50	11.75	13.88	4.62	2.50	2.75	9.62	6.75	6.50	4	3/4
4 15/16 5	RPB-415-4 RPB-500-4	RPB-415-C4 RPB-500-C4	RPB-415-N4 RPB-500-N4	143.6	5.50	18.50	13.50	15.88	5.12	2.75	3.12	11.00	7.25	7.31	4	7/8

See page 105 for seal arrangements. (1) High temp units are factory assembled-to-order basis.  
For Load Ratings, see page 121.

# SEALMASTER® MOUNTED ROLLER BEARINGS

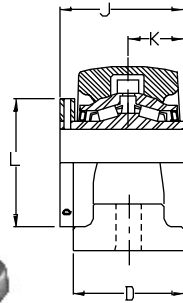

Two Bolt Base

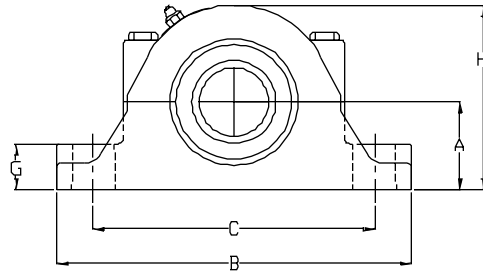

The RPB-A series is similar in design to RPB series, but has only one locking collar, and is recommended where axial shaft space is limited.

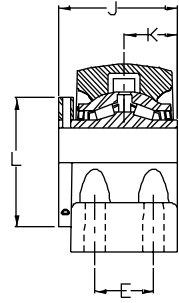

Four Bolt Base

## RPB-A Series Pillow Blocks...Two Bolt Base

SHAFT DIAM. IN.	STANDARD SEAL PART NO.	CONTACT SEAL PART NO.	HI-TEMP (1) SEAL PART NO.	APPROX. WT. IN LBS.	DIMENSIONS IN INCHES											BASE BOLTS	
					A	B	C		D	E	G	H	J	K	L	NO.	SIZE
							MIN.	MAX.									
1 3/16	RPBA-103-2	RPBA-103-C2	RPBA-103-N2	4.8	1.50	6.25	4.56	4.94	1.88	-	.88	3.12	2.37	1.00	2.25	2	1/2
1 1/4	RPBA-104-2	RPBA-104-C2	RPBA-104-N2				5.31	5.94									
1 3/8	RPBA-106-2	RPBA-106-C2	RPBA-106-N2	7.7	1.88	7.25	5.31	5.94	2.06	-	1.12	3.81	2.53	1.15	2.62	2	1/2
1 7/16	RPBA-107-2	RPBA-107-C2	RPBA-107-N2				5.56	6.44									
1 1/2	RPBA-108-2	RPBA-108-C2	RPBA-108-N2	10.9	2.12	7.75	5.56	6.44	2.31	-	1.25	4.38	2.84	1.15	2.88	2	1/2
1 5/8	RPBA-110-2	RPBA-110-C2	RPBA-110-N2				6.31	7.19									
1 11/16	RPBA-111-2	RPBA-111-C2	RPBA-111-N2				6.31	7.19									
1 3/4	RPBA-112-2	RPBA-112-C2	RPBA-112-N2	13.2	2.25	8.88	6.31	7.19	2.44	-	1.25	4.62	2.95	1.20	3.25	2	5/8
1 15/16	RPBA-115-2	RPBA-115-C2	RPBA-115-N2				6.69	7.94									
2	RPBA-200-2	RPBA-200-C2	RPBA-200-N2				6.69	7.94									
2 3/16	RPBA-203-2	RPBA-203-C2	RPBA-203-N2	15.7	2.50	9.62	6.69	7.94	2.56	-	1.44	5.12	3.12	1.25	3.62	2	5/8
2 1/4	RPBA-204-2	RPBA-204-C2	RPBA-204-N2	20.7	2.75	10.38	6.94	8.69	2.75	-	1.82	5.62	3.31	1.31	3.94	2	5/8
2 7/16	RPBA-207-2	RPBA-207-C2	RPBA-207-N2				8.06	9.69									
2 1/2	RPBA-208-2	RPBA-208-C2	RPBA-208-N2				8.06	9.69									
2 11/16	RPBA-211-2	RPBA-211-C2	RPBA-211-N2	29.3	3.12	11.75	8.06	9.69	3.00	-	1.75	6.38	3.69	1.44	4.75	2	3/4
2 3/4	RPBA-212-2	RPBA-212-C2	RPBA-212-N2				10.12	11.25									
2 15/16	RPBA-215-2	RPBA-215-C2	RPBA-215-N2				10.12	11.25									
3	RPBA-300-2	RPBA-300-C2	RPBA-300-N2				10.12	11.25									
3 3/16	RPBA-303-2	RPBA-303-C2	RPBA-303-N2	56.0	3.75	13.75	10.12	11.25	4.12	-	2.06	7.75	4.19	1.89	5.55	2	7/8
3 7/16	RPBA-307-2	RPBA-307-C2	RPBA-307-N2				10.12	11.25									
3 1/2	RPBA-308-2	RPBA-308-C2	RPBA-308-N2				10.12	11.25									

## RPB-A Series Pillow Blocks...Four Bolt Base

SHAFT DIAM. IN.	STANDARD SEAL PART NO.	CONTACT SEAL PART NO.	HI-TEMP (1) SEAL PART NO.	APPROX. WT. IN LBS.	DIMENSIONS IN INCHES											BASE BOLTS	
					A	B	C		D	E	G	H	J	K	L	NO.	SIZE
							MIN.	MAX.									
2 1/4	RPBA-204-4	RPBA-204-C4	RPBA-204-N4	22.4	2.75	10.38	7.75	8.75	3.50	1.88	1.82	5.62	3.31	1.31	3.94	4	5/8
2 7/16	RPBA-207-4	RPBA-207-C4	RPBA-207-N4				8.75	10.00									
2 1/2	RPBA-208-4	RPBA-208-C4	RPBA-208-N4				8.75	10.00									
2 11/16	RPBA-211-4	RPBA-211-C4	RPBA-211-N4	31.5	3.12	11.75	8.75	10.00	3.75	2.12	1.75	6.38	3.69	1.44	4.75	4	3/4
2 3/4	RPBA-212-4	RPBA-212-C4	RPBA-212-N4				10.12	11.25									
2 15/16	RPBA-215-4	RPBA-215-C4	RPBA-215-N4				10.12	11.25									
3	RPBA-300-4	RPBA-300-C4	RPBA-300-N4				10.12	11.25									
3 3/16	RPBA-303-4	RPBA-303-C4	RPBA-303-N4	59.8	3.75	13.75	10.56	11.50	4.50	2.38	2.06	7.75	4.19	1.89	5.55	4	7/8
3 7/16	RPBA-307-4	RPBA-307-C4	RPBA-307-N4				10.56	11.50									
3 1/2	RPBA-308-4	RPBA-308-C4	RPBA-308-N4				10.56	11.50									
3 15/16	RPBA-315-4	RPBA-315-C4	RPBA-315-N4	76.9	4.25	15.25	11.00	13.00	4.50	2.25	2.44	8.62	5.25	2.13	6.00	4	5/8
4	RPBA-400-4	RPBA-400-C4	RPBA-400-N4				11.00	13.00									
4 7/16	RPBA-407-4	RPBA-407-C4	RPBA-407-N4				11.00	13.00									
4 1/2	RPBA-408-4	RPBA-408-C4	RPBA-408-N4	95.6	4.75	16.50	11.75	13.88	4.62	2.50	2.87	9.63	5.50	2.12	6.50	4	3/4
4 1/2	RPBA-408-4	RPBA-408-C4	RPBA-408-N4				11.75	13.88									
4 15/16	RPBA-415-4	RPBA-415-C4	RPBA-415-N4				11.75	13.88									
5	RPBA-500-4	RPBA-500-C4	RPBA-500-N4	143.6	5.50	18.50	13.50	15.88	5.12	2.75	3.12	11.00	6.21	2.58	7.31	4	7/8



**Felt Seal Standard**  
Positive sealing for low, medium, and high speed operation.



**Hi-Temp Seal**  
Available as an option where operating temperatures are in 250-400° range.



**Single Lip Contact Seal**  
Available on all sizes. Recommended where moisture conditions prevail.

For Replacement Cartridge Insert See Page 120.  
For Load Ratings See Page 121.  
For Metric Bores, See Page 127.

(1) Hi-Temp Units are factory assembled-to-order basis.



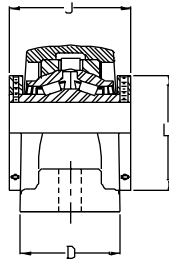

Two Bolt Base

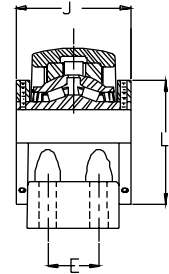
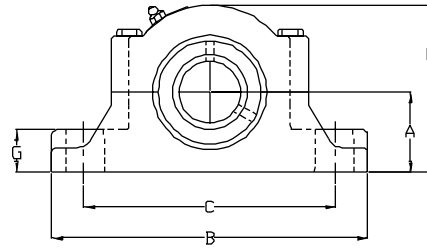

Four Bolt Base

## ERPB Series Expansion Type Pillow Blocks...Two Bolt Base

SHAFT DIAM. IN.	STANDARD SEAL PART NO.	CONTACT SEAL PART NO.	HI-TEMP (1) SEAL PART NO.	APPROX. WT. IN LBS.	DIMENSIONS IN INCHES										BASE BOLTS		TOTAL EXPANSION
					A	B	C		D	E	G	H	J	L	NO.	SIZE	
							MIN.	MAX.									
1 3/4 1 15/16 2	ERP-112-2 ERP-115-2 ERP-200-2	ERP-112-C2 ERP-115-C2 ERP-200-C2	ERP-112-N2 ERP-115-N2 ERP-200-N2	14.9	2.25	8.88	6.31	7.19	2.89	—	1.25	4.88	3.50	3.25	2	5/8	3/16
2 3/16	ERP-203-2	ERP-203-C2	ERP-203-N2	17.8	2.50	9.62	6.69	7.94	3.03	—	1.44	5.31	3.75	3.62	2	5/8	3/16
2 1/4 2 7/16 2 1/2	ERP-204-2 ERP-207-2 ERP-208-2	ERP-204-C2 ERP-207-C2 ERP-208-C2	ERP-204-N2 ERP-207-N2 ERP-208-N2	23.0	2.75	10.38	6.94	8.69	3.41	—	1.62	5.75	4.00	3.94	2	5/8	1/4
2 11/16 2 3/4 2 15/16 3	ERP-211-2 ERP-212-2 ERP-215-2 ERP-300-2	ERP-211-C2 ERP-212-C2 ERP-215-C2 ERP-300-C2	ERP-211-N2 ERP-212-N2 ERP-215-N2 ERP-300-N2	32.0	3.12	11.75	8.06	9.69	3.48	—	1.75	6.56	4.50	4.75	2	3/4	5/16
3 3/16 3 7/16 3 1/2	ERP-303-2 ERP-307-2 ERP-308-2	ERP-303-C2 ERP-307-C2 ERP-308-C2	ERP-303-N2 ERP-307-N2 ERP-308-N2	64.0	3.75	13.75	10.12	11.25	4.51	—	2.06	7.94	5.00	5.55	2	7/8	5/16

## ERPB Series Expansion Type Pillow Blocks...Four Bolt Base

SHAFT DIAM. IN.	STANDARD SEAL PART NO.	CONTACT SEAL PART NO.	HI-TEMP (1) SEAL PART NO.	APPROX. WT. IN LBS.	DIMENSIONS IN INCHES										BASE BOLTS		TOTAL EXPANSION
					A	B	C		D	E	G	H	J	L	NO.	SIZE	
							MIN.	MAX.									
3 15/16 4	ERP-315-4 ERP-400-4	ERP-315-C4 ERP-400-C4	ERP-315-N4 ERP-400-N4	90.0	4.25	15.25	11.00	13.00	5.15	2.25	2.44	8.88	6.25	6.00	4	3/4	3/8
4 7/16 4 1/2	ERP-407-4 ERP-408-4	ERP-407-C4 ERP-408-C4	ERP-407-N4 ERP-408-N4	110.6	4.75	16.50	11.75	13.88	5.35	2.50	2.75	9.88	6.75	6.50	4	3/4	3/8
4 15/16 5	ERP-415-4 ERP-500-4	ERP-415-C4 ERP-500-C4	ERP-415-N4 ERP-500-N4	161.0	5.50	18.50	13.50	15.88	6.07	2.75	3.12	11.31	7.25	7.31	4	7/8	3/8

The ERPB series of expansion roller bearing pillow blocks is designed for use in conjunction with the RPB and RPBA series where a "floating" or expansion type block is required.

While two fixed units mounted on one shaft are normally satisfactory for most applications, expansion units are recommended:

1. Where bearing supports are not rigid.
2. Where significant temperature differentials are expected between shafts and mounting structures.
3. Where shaft is unusually long.

At least one bearing on each shaft must be of the fixed type.

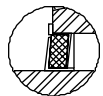

**Felt Seal Standard**  
Positive sealing for low, medium, and high speed operation.

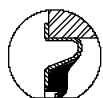

**Single Lip Contact Seal**  
Available on all sizes. Recommended where moisture conditions prevail.

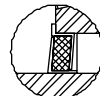

**Hi-Temp Seal**  
Available as an option where operating temperatures are in 250-400° range.

For Replacement Cartridge Insert See Page 120.

For Load Ratings See Page 121.

For Metric Bores, See Page 127.

(1) Hi-Temp Units are factory assembled-to-order basis.

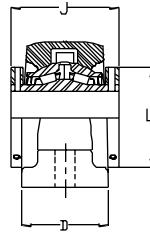

Two Bolt Base

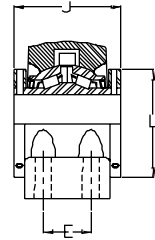
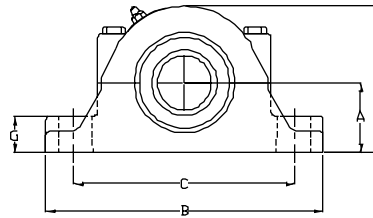

Four Bolt Base

## DRPB Series Pillow Blocks...Two Bolt Base (DI INTERCHANGE)

SHAFT DIAM. IN.	STANDARD SEAL PART NO.	CONTACT SEAL PART NO.	HI-TEMP (1) SEAL PART NO.	APPROX. WT. IN LBS.	DIMENSIONS IN INCHES										BASE BOLTS	
					A	B	C		D	E	G	H	J	L	NO.	SIZE
							MIN.	MAX								
1 3/4 1 15/16 2	DRPB-112-2	DRPB-112-C2	DRPB-112-N2	17.5	2.88	10.00	6.75	8.50	2.57	—	1.50	5.25	3.50	3.25	2	5/8
	DRPB-115-2	DRPB-115-C2	DRPB-115-N2													
	DRPB-200-2	DRPB-200-C2	DRPB-200-N2													
2 3/16	DRPB-203-2	DRPB-203-C2	DRPB-203-N2	19.7	3.00	11.00	7.75	9.25	2.56	—	1.56	5.62	3.75	3.62	2	5/8
2 1/4 2 7/16 2 1/2	DRPB-204-2	DRPB-204-C2	DRPB-204-N2	25.5	3.25	12.00	8.50	10.38	2.88	—	1.75	6.12	4.00	3.94	2	5/8
	DRPB-207-2	DRPB-207-C2	DRPB-207-N2													
	DRPB-208-2	DRPB-208-C2	DRPB-208-N2													
2 11/16 2 3/4 2 15/16 3	DRPB-211-2	DRPB-211-C2	DRPB-211-N2	35.2	3.75	13.50	9.32	11.56	3.12	—	2.00	7.00	4.50	4.75	2	3/4
	DRPB-212-2	DRPB-212-C2	DRPB-212-N2													
	DRPB-215-2	DRPB-215-C2	DRPB-215-N2													
	DRPB-300-2	DRPB-300-C2	DRPB-300-N2													
3 3/16 3 7/16 3 1/2	DRPB-303-2	DRPB-303-C2	DRPB-303-N2	67.8	4.50	16.00	10.87	13.27	4.38	—	2.25	8.50	5.00	5.55	2	7/8
	DRPB-307-2	DRPB-307-C2	DRPB-307-N2													
	DRPB-308-2	DRPB-308-C2	DRPB-308-N2													

## DRPB Series Pillow Blocks...Four Bolt Base (DI INTERCHANGE)

SHAFT DIAM. IN.	STANDARD SEAL PART NO.	CONTACT SEAL PART NO.	HI-TEMP (1) SEAL PART NO.	APPROX. WT. IN LBS.	DIMENSIONS IN INCHES										BASE BOLTS	
					A	B	C		D	E	G	H	J	L	NO.	SIZE
							MIN.	MAX								
3 15/16 4	DRPB-315-4 DRPB-400-4	DRPB-315-C4 DRPB-400-C4	DRPB-315-N4 DRPB-400-N4	93.0	5.00	17.50	12.00	15.00	4.67	2.00	2.75	9.38	6.25	6.00	4	3/4

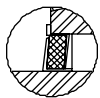

**Felt Seal Standard**  
Positive sealing for low, medium, and high speed operation.

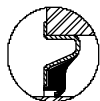

**Single Lip Contact Seal**  
Available on all sizes. Recommended where moisture conditions prevail.

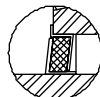

**Hi-Temp Seal**  
Available as an option where operating temperatures are in 250-400° range.

The DRPB units have a high base-to shaft centerline and wide base mounting dimensions, and are interchangeable with competitive "DI" types. Bearing load and speed capabilities are equal to RPB.

For Replacement Cartridge Insert See Page 120.

For Load Ratings See Page 121.

For Metric Bores, See Page 127.

(1) Hi-Temp Units are factory assembled-to-order basis.

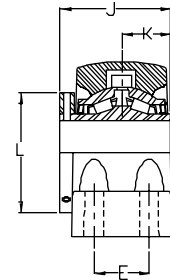
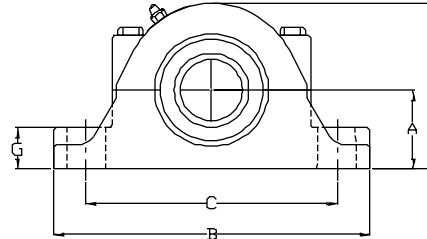
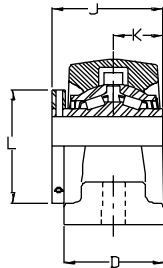

Two Bolt Base

Four Bolt Base

## DRPB-A Series Pillow Blocks...Two Bolt Base (K INTERCHANGE)

SHAFT DIAM. IN.	STANDARD SEAL PART NO.	CONTACT SEAL PART NO.	HI-TEMP (1) SEAL PART NO.	APPROX. WT. IN LBS.	DIMENSIONS IN INCHES											BASE BOLTS	
					A	B	C		D	E	G	H	J	K	L	NO.	SIZE
							MIN.	MAX.									
1 3/4 1 15/16 2	DRPBA-112-2 DRPBA-115-2 DRPBA-200-2	DRPBA-112-C2 DRPBA-115-C2 DRPBA-200-C2	DRPBA-112-N2 DRPBA-115-N2 DRPBA-200-N2	17.5	2.88	10.00	6.75	8.50	2.57	—	1.50	5.25	2.95	1.20	3.25	2	5/8
2 3/16	DRPBA-203-2	DRPBA-203-C2	DRPBA-203-N2	19.7	3.00	11.00	7.75	9.25	2.56	—	1.56	5.62	3.12	1.25	3.62	2	5/8
2 1/4 2 7/16 2 1/2	DRPBA-204-2 DRPBA-207-2 DRPBA-208-2	DRPBA-204-C2 DRPBA-207-C2 DRPBA-208-C2	DRPBA-204-N2 DRPBA-207-N2 DRPBA-208-N2	25.5	3.25	12.00	8.50	10.38	2.88	—	1.75	6.12	3.31	1.31	3.94	2	5/8
2 11/16 2 3/4 2 15/16 3	DRPBA-211-2 DRPBA-212-2 DRPBA-215-2 DRPBA-300-2	DRPBA-211-C2 DRPBA-212-C2 DRPBA-215-C2 DRPBA-300-C2	DRPBA-211-N2 DRPBA-212-N2 DRPBA-215-N2 DRPBA-300-N2	35.2	3.75	13.50	9.32	11.56	3.12	—	2.00	7.00	3.69	1.44	4.75	2	3/4
3 3/16 3 7/16 3 1/2	DRPBA-303-2 DRPBA-307-2 DRPBA-308-2	DRPBA-303-C2 DRPBA-307-C2 DRPBA-308-C2	DRPBA-303-N2 DRPBA-307-N2 DRPBA-308-N2	67.8	4.50	16.00	10.87	13.27	4.38	—	2.25	8.50	4.19	1.69	5.55	2	7/8

## DRPB-A Series Pillow Blocks...Four Bolt Base (K INTERCHANGE)

SHAFT DIAM. IN.	STANDARD SEAL PART NO.	CONTACT SEAL PART NO.	HI-TEMP (1) SEAL PART NO.	APPROX. WT. IN LBS.	DIMENSIONS IN INCHES											BASE BOLTS	
					A	B	C		D	E	G	H	J	K	L	NO.	SIZE
							MIN.	MAX.									
3 15/16 4	DRPBA-315-4 DRPBA-400-4	DRPBA-315-C4 DRPBA-400-C4	DRPBA-315-N4 DRPBA-400-N4	93.0	5.00	17.50	12.00	15.00	4.67	2.00	2.75	9.38	5.25	2.13	6.00	4	3/4

See page 109 for seal arrangements.

(1) High temp units are factory assembled-to-order basis.

The DRPB-A units have a high base-to shaft centerline and wide base mounting dimensions, and are interchangeable with competitive "K" types. Bearing load and speed capabilities are equal to RPB. The DRPB-A series units are similar in design to DRPB series, but have only one cone extension and one locking collar, and are recommended where axial shaft space is limited.

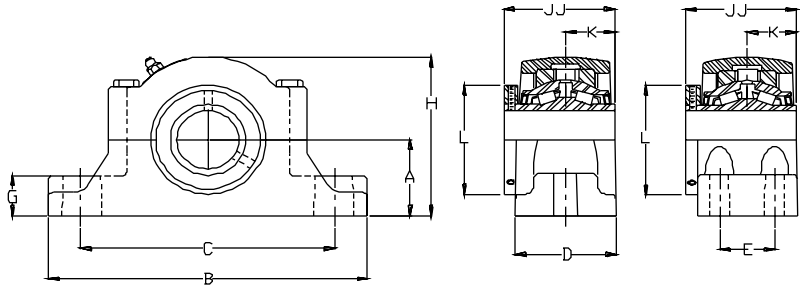

Two Bolt Base Four Bolt Base

## EDPB-A Series Expansion Type Pillow Blocks...Two Bolt Base

SHAFT DIAM. IN.	STANDARD SEAL PART NO.	CONTACT SEAL PART NO.	HI-TEMP (1) SEAL PART NO.	APPROX. WT. IN LBS.	DIMENSIONS IN INCHES											BASE BOLTS		TOTAL EXPANSION
					A	B	C		D	E	G	H	JJ	K	L	NO.	SIZE	
							MIN.	MAX.										
1 3/4 1 15/16 2	EDPBA-112-2 EDPBA-115-2 EDPBA-200-2	EDPBA-112-C2 EDPBA-115-C2 EDPBA-200-C2	EDPBA-112-N2 EDPBA-115-N2 EDPBA-200-N2	19.2	2.88	10.00	6.75	8.50	2.57	—	1.50	5.50	2.95	1.20	3.25	2	5/8	3/16
2 3/16	EDPBA-203-2	EDPBA-203-C2	EDPBA-203-N2	21.8	3.00	11.00	7.75	9.25	2.56	—	1.56	5.81	3.12	1.25	3.62	2	5/8	3/16
2 1/4 2 7/16 2 1/2	EDPBA-204-2 EDPBA-207-2 EDPBA-208-2	EDPBA-204-C2 EDPBA-207-C2 EDPBA-208-C2	EDPBA-204-N2 EDPBA-207-N2 EDPBA-208-N2	27.8	3.25	12.00	8.50	10.38	2.88	—	1.75	6.25	3.31	1.31	3.94	2	5/8	1/4
2 11/16 2 3/4 2 15/16 3	EDPBA-211-2 EDPBA-212-2 EDPBA-215-2 EDPBA-300-2	EDPBA-211-C2 EDPBA-212-C2 EDPBA-215-C2 EDPBA-300-C2	EDPBA-211-N2 EDPBA-212-N2 EDPBA-215-N2 EDPBA-300-N2	38.0	3.75	13.50	9.32	11.56	3.12	—	2.00	7.18	3.69	1.44	4.75	2	3/4	5/16
3 3/16 3 7/16 3 1/2	EDPBA-303-2 EDPBA-307-2 EDPBA-308-2	EDPBA-303-C2 EDPBA-307-C2 EDPBA-308-C2	EDPBA-303-N2 EDPBA-307-N2 EDPBA-308-N2	75.8	4.50	16.00	10.87	13.27	4.38	—	2.25	8.69	4.19	1.69	5.55	2	7/8	5/16

## EDPB-A Series Expansion Type Pillow Blocks...Four Bolt Base

SHAFT DIAM. IN.	STANDARD SEAL PART NO.	CONTACT SEAL PART NO.	HI-TEMP (1) SEAL PART NO.	APPROX. WT. IN LBS.	DIMENSIONS IN INCHES											BASE BOLTS		TOTAL EXPANSION
					A	B	C		D	E	G	H	JJ	K	L	NO.	SIZE	
							MIN.	MAX.										
3 15/16 4	EDPBA-315-4 EDPBA-400-4	EDPBA-315-C4 EDPBA-400-C4	EDPBA-315-N4 EDPBA-400-N4	106.00	5.00	17.50	12.00	15.00	4.67	2.00	2.75	9.62	5.25	2.13	6.00	4	3/4	3/8

The EDPB-A series of expansion roller bearing pillow blocks with single locking collar is designed for use in conjunction with the DRPB-A series where a "floating" or expansion type block is required.

Matching mounting dimensions provides for ease in application.

While two fixed units mounted on one shaft are normally satisfactory for most applications, expansion units are recommended:

1. Where bearing supports are not rigid.
2. Where significant temperature differentials are expected between shafts and mounting structures.
3. Where shaft is unusually long.

At least one bearing on each shaft must be of the fixed type.



**Felt Seal Standard**  
Positive sealing for low, medium, and high speed operation.



**Single Lip Contact Seal**  
Available on all sizes. Recommended where moisture conditions prevail.



**Hi-Temp Seal**  
Available as an option where operating temperatures are in 250-400° range.

For Replacement Cartridge Insert See Page 120.

For Load Ratings See Page 121.

For Metric Bores, See Page 127.

(1) Hi-Temp Units are factory assembled-to-order basis.

# TOUGH AS THEY COME!

## RPBXT and ERPBXT Mounted Roller Bearings...

*The Time-Savers...*



### That are a Dimensional Interchange with SAF... Bearings

The RPBXT/ERPBXT lines offer users significantly reduced costs for assembly and installation. This line of four-bolt nonexpansion (RPBXT) and expansion (ERPBXT) roller bearing pillow blocks is available in bore sizes from 2 1/4" through 5". It offers users a factory assembled, self-aligning, mounted tapered roller bearing unit that *interchanges* shaft-to-centerline and bolt hole spacing with the popular 500 series SAF style spherical roller bearing pillow blocks.

### RPBXT Series Bearings Eliminate Assembly and Adjustment at Installation.

When users replace 500 series SAF style pillow blocks with the New SEALMASTER RPBXT, installation is *easier* and *faster*. Here's why:

RPBXT Units	VS	SAF Units
<ul style="list-style-type: none"> <li>• RPBXT units are fully-assembled, sealed and factory lubricated, ready to install right onto the shaft when they're received. <i>You save time and money.</i></li> <li>• At installation, the RPBXT unit is simply secured to the shaft with concentric double locking collars, each of which has two setscrews at 120°, providing balanced three-point contact and symmetrical locking.</li> </ul>		<ul style="list-style-type: none"> <li>• SAF Units require complete assembly: The bearing, housing, seals, adapter nut, sleeve and washer are <i>all</i> shipped loose. The user must assemble <i>all</i> components, adjust bearing clearances during assembly and lubricate the bearing unit.</li> <li>• SAF Units are locked to the shaft with an adapter sleeve and tightened with a locknut/lockwasher assembly.</li> </ul>

**Misalignment is a Tough Challenge for Bearings and Seals... RPBXT Handles it Better!**

RPBXT Units	VS	SAF Units
<p>RPBXT units have race mounted seals that move with the cartridge insert and are <i>not</i> subjected to shaft misalignment stress. RPBXT Seals can accommodate up to ± 3° degrees of shaft misalignment stress without loss of seal effectiveness. RPBXT roller bearings offer the user a wide choice of seals to suit application needs including patented labyrinth seals, proven in thousands of applications, a single lip contact seal, or the high temperature (Nomex) seal. Once the lubricant permeates the felt (seal), a lower coefficient of friction (reduced drag) and extended operating life result.</p>		<p>SAF style pillow blocks operate successfully in misaligned conditions up to ± 1 1/2° because the spherical O.D. of the bearing matches the spherical I.D. of the outer race. Thus, misalignment is internal. The seals however are mounted between the stationary housing and the shaft and are subject to movement when misaligned. The seals are designed with clearances to allow for the movement therefore reducing their effectiveness.</p>

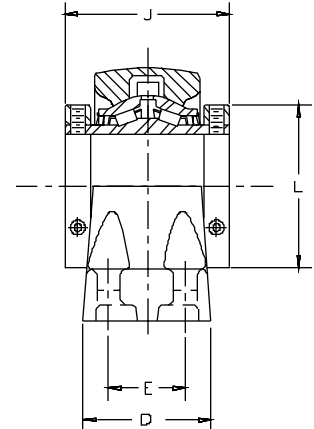
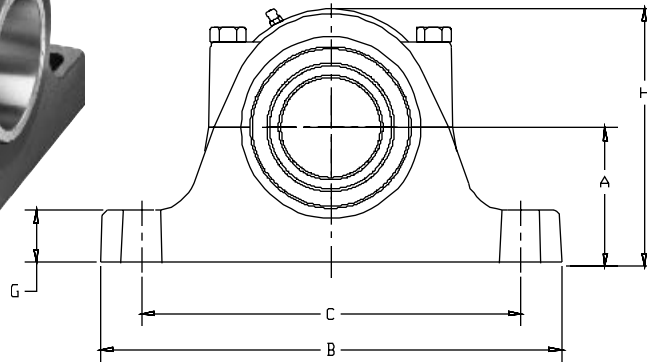
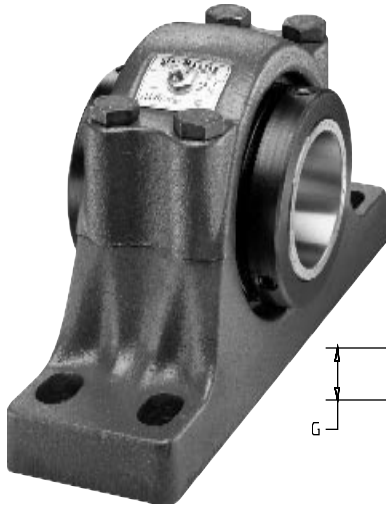

## RPBXT Series Pillow Blocks...Four Bolt Base

SHAFT DIAM. IN.	STANDARD SEAL PART NO.	CONTACT SEAL PART NO.	HI-TEMP (1) SEAL PART NO.	APPROX. WT. IN LBS.	DIMENSIONS IN INCHES										BASE BOLTS	
					A	B	C		D	E	G	H	J	L	NO.	SIZE
							MIN.	MAX.								
2 1/4 2 7/16 2 1/2	RPBXT-204-4 RPBXT-207-4 RPBXT-208-4	RPBXT-204-C4 RPBXT-207-C4 RPBXT-208-C4	RPBXT-204-N4 RPBXT-207-N4 RPBXT-208-N4	25.5	3.25	11.25	8.62	9.62	3.12	1.88	1.25	6.12	4.00	3.94	4	1/2
2 11/16 2 3/4 2 15/16 3	RPBXT-211-4 RPBXT-212-4 RPBXT-215-4 RPBXT-300-4	RPBXT-211-C4 RPBXT-212-C4 RPBXT-215-C4 RPBXT-300-C4	RPBXT-211-N4 RPBXT-212-N4 RPBXT-215-N4 RPBXT-300-N4	36.2	3.75	13.00	10.00	11.00	3.50	2.12	1.50	7.00	4.50	4.75	4	5/8
3 1/4 3 7/16 3 1/2	RPBXT-304-4 RPBXT-307-4 RPBXT-308-4	RPBXT-304-C4 RPBXT-307-C4 RPBXT-308-C4	RPBXT-304-N4 RPBXT-307-N4 RPBXT-308-N4	67.8	4.50	15.25	11.75	12.75	4.38	2.38	1.75	8.50	5.00	5.55	4	3/4
3 15/16 4	RPBXT-315-4 RPBXT-400-4	RPBXT-315-C4 RPBXT-400-C4	RPBXT-315-N4 RPBXT-400-N4	93.0	4.94	16.50	12.88	14.12	4.75	2.75	2.00	9.31	6.25	6.00	4	3/4
4 7/16 4 1/2	RPBXT-407-4 RPBXT-408-4	RPBXT-407-C4 RPBXT-408-C4	RPBXT-407-N4 RPBXT-408-N4	114.7	6.00	18.38	14.50	16.00	5.25	3.25	2.50	10.88	6.75	6.50	4	7/8
4 15/16 5	RPBXT-415-4 RPBXT-500-4	RPBXT-415-C4 RPBXT-500-C4	RPBXT-415-N4 RPBXT-500-N4	172.4	6.00	20.12	15.62	17.38	6.00	3.38	2.50	11.50	7.25	7.31	4	1

## ERPBT Series Pillow Blocks...Four Bolt Base

SHAFT DIAM. IN.	STANDARD SEAL PART NO.	CONTACT SEAL PART NO.	HI-TEMP (1) SEAL PART NO.	APPROX. WT. IN LBS.	DIMENSIONS IN INCHES										BASE BOLTS	
					A	B	C		D	E	G	H	J	L	NO.	SIZE
							MIN.	MAX.								
2 1/4 2 7/16 2 1/2	ERPBT-204-4 ERPBT-207-4 ERPBT-208-4	ERPBT-204-C4 ERPBT-207-C4 ERPBT-208-C4	ERPBT-204-N4 ERPBT-207-N4 ERPBT-208-N4	27.7	3.25	11.25	8.62	9.62	3.42	1.88	1.25	6.25	4.00	3.94	4	1/2
2 11/16 2 3/4 2 15/16 3	ERPBT-211-4 ERPBT-212-4 ERPBT-215-4 ERPBT-300-4	ERPBT-211-C4 ERPBT-212-C4 ERPBT-215-C4 ERPBT-300-C4	ERPBT-211-N4 ERPBT-212-N4 ERPBT-215-N4 ERPBT-300-N4	39.0	3.75	13.00	10.00	11.00	3.50	2.12	1.50	7.19	4.50	4.75	4	5/8
3 1/4 3 7/16 3 1/2	ERPBT-304-4 ERPBT-307-4 ERPBT-308-4	ERPBT-304-C4 ERPBT-307-C4 ERPBT-308-C4	ERPBT-304-N4 ERPBT-307-N4 ERPBT-308-N4	75.3	4.50	15.25	11.75	12.75	4.50	2.38	1.75	8.69	5.00	5.55	4	3/4
3 15/16 4	ERPBT-315-4 ERPBT-400-4	ERPBT-315-C4 ERPBT-400-C4	ERPBT-315-N4 ERPBT-400-N4	106.0	4.94	16.50	12.88	14.12	5.18	2.75	2.00	9.56	6.25	6.00	4	3/4
4 7/16 4 1/2	ERPBT-407-4 ERPBT-408-4	ERPBT-407-C4 ERPBT-408-C4	ERPBT-407-N4 ERPBT-408-N4	140.0	6.00	18.38	14.50	16.00	5.40	3.25	2.50	11.13	6.75	6.50	4	7/8
4 15/16 5	ERPBT-415-4 ERPBT-500-4	ERPBT-415-C4 ERPBT-500-C4	ERPBT-415-N4 ERPBT-500-N4	190.0	6.00	20.12	15.62	17.38	6.09	3.38	2.50	11.81	7.25	7.31	4	1

See page 109 for seal arrangements. (1) High temp units are factory assembled-to-order basis.  
For Load Ratings, See Page 121.

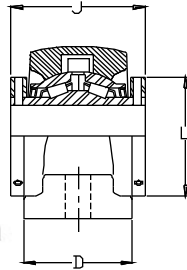

Two Bolt Base

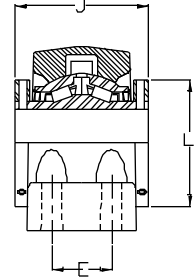
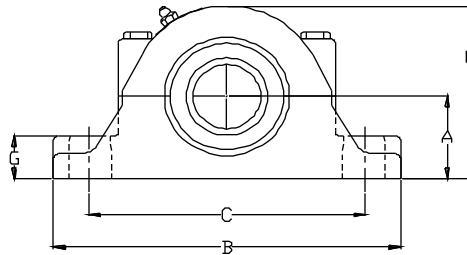

Four Bolt Base

## SPB Series Pillow Blocks...Two Bolt Base (Cast Steel Housing)

SHAFT DIAM. IN.	STANDARD SEAL PART NO.	CONTACT SEAL PART NO.	HI-TEMP (1) SEAL PART NO.	APPROX. WT. IN LBS.	DIMENSIONS IN INCHES										BASE BOLTS	
					A	B	C		D	E	G	H	J	L	NO.	SIZE
							MIN.	MAX.								
1 1/2 1 5/8 1 11/16	SPB-108-2 SPB-110-2 SPB-111-2	SPB-108-C2 SPB-110-C2 SPB-111-C2	SPB-108-N2 SPB-110-N2 SPB-111-N2	12.0	2.12	7.75	5.56	6.44	2.31	—	1.25	4.38	3.38	2.88	2	1/2
1 3/4 1 15/16 2	SPB-112-2 SPB-115-2 SPB-200-2	SPB-112-C2 SPB-115-C2 SPB-200-C2	SPB-112-N2 SPB-115-N2 SPB-200-N2	14.5	2.25	8.88	6.31	7.19	2.44	—	1.25	4.62	3.50	3.25	2	5/8
2 3/16	SPB-203-2	SPB-203-C2	SPB-203-N2	17.3	2.50	9.62	6.69	7.94	2.56	—	1.44	5.12	3.75	3.62	2	5/8
2 1/4 2 7/16 2 1/2	SPB-204-2 SPB-207-2 SPB-308-2	SPB-204-C2 SPB-207-C2 SPB-208-C2	SPB-204-N2 SPB-207-N2 SPB-208-N2	22.8	2.75	10.38	6.94	8.69	2.75	—	1.62	5.62	4.00	3.94	2	5/8
2 11/16 2 3/4 2 15/16 3	SPB-211-2 SPB-212-2 SPB-215-2 SPB-300-2	SPB-211-C2 SPB-212-C2 SPB-213-C2 SPB-300-C2	SPB-211-N2 SPB-212-N2 SPB-213-N2 SPB-300-N2	32.2	3.12	11.75	8.06	9.69	3.00	—	1.75	6.38	4.50	4.75	2	3/4
3 3/16 3 7/16 3 1/2	SPB-303-2 SPB-307-2 SPB-308-2	SPB-303-C2 SPB-307-C2 SPB-308-C2	SPB-303-N2 SPB-307-N2 SPB-308-N2	65.6	3.75	13.75	10.12	11.25	4.12	—	2.06	7.75	5.00	5.55	2	7/8

## SPB Series Pillow Blocks...Four Bolt Base (Cast Steel Housing)

SHAFT DIAM. IN.	STANDARD SEAL PART NO.	CONTACT SEAL PART NO.	HI-TEMP (1) SEAL PART NO.	APPROX. WT. IN LBS.	DIMENSIONS IN INCHES										BASE BOLTS	
					A	B	C		D	E	G	H	J	L	NO.	SIZE
							MIN.	MAX.								
3 15/16 4	SPB-315-4 SPB-400-4	SPB-315-C4 SPB-400-C4	SPB-315-N4 SPB-400-N4	84.6	4.25	15.25	11.00	13.00	4.50	2.25	2.44	8.62	6.25	6.00	4	3/4
4 7/16 4 1/2	SPB-407-4 SPB-408-4	SPB-407-C4 SPB-408-C4	SPB-407-N4 SPB-408-N4	105.2	4.75	16.50	11.75	13.88	4.62	2.50	2.75	9.62	6.75	6.50	4	3/4
4 15/16 5	SPB-415-4 SPB-500-4	SPB-415-C4 SPB-500-C4	SPB-415-N4 SPB-500-N4	158.0	5.50	18.50	13.50	15.88	5.12	2.75	3.12	11.00	7.25	7.31	4	7/8

See page 109 for seal arrangements. (1) High temp units are factory assembled-to-order basis.

The SPB series pillow blocks use a rugged cast steel housing which provides maximum housing strength at a given unit weight. These factory assembled-to-order units have housings meeting SAE J43T specifications, 65,000 PSI. They come with Sealmaster felt lined flinger seals as standard but the contact or Hi-Temp seal may be specified.

For Load Ratings, See Page 121.

# TOUGH AS THEY COME!

## ***FLANGE UNITS...***

Sealmaster split housed four-bolt flange units are designed for face mounting against vertical or horizontal structures where a minimum amount of machining is required. These flange housings have machined foot pads on the base to facilitate installation and removal of double locking collar styles. Flange units are available from 1 3/16" to 4 1/2" bore sizes in both single and double locking collars.

These units can be supplied with a choice of *three seals; felt, contact and high temperature nomex*. They are strongest when loads are applied in the thrust direction through the machined face.

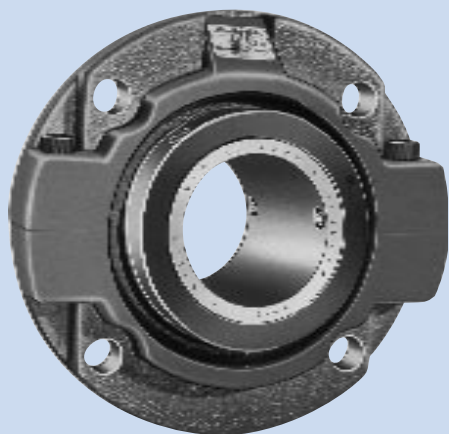
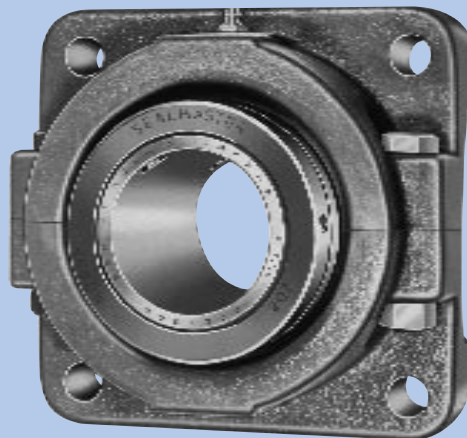

## ***PILOTED FLANGE UNITS...***

Sealmaster split housed piloted flange units are commonly used in applications where rotating and eccentric loads are present. Typical applications include vibrating conveyors material handling, construction, and mixers. The combination of flange and pilot features allow them to be integrally mounted in both horizontal and vertical shaft applications.

The split housing is designed with a machined pilot extension that provides added support, thus reducing stress on the mounting bolts. Sealmaster piloted flange housings are round and stocked in *shaft sizes from 1 3/16" - 5"*. *Units through 4" contain four mounting bolts; sizes 4 7/16" through 5" contain six mounting bolts*. These units can be supplied with a *choice of three seals; felt, contact and high temperature nomex*. This series is available with both single and double lock collars. Provisions should be incorporated to facilitate installation and removal of double locking collar styles.



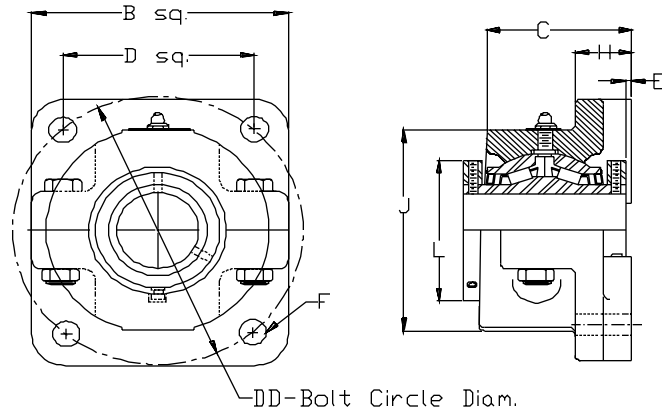
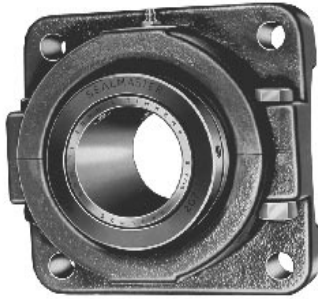

## RFB Series Flange Units

SHAFT DIAM. IN.	STANDARD SEAL	CONTACT SEAL	HI-TEMP (1) SEAL	APPROX. WT. IN LBS.	DIMENSIONS IN INCHES									
	PART NO.	PART NO.	PART NO.		A	B	C	D	DD	E	F BOLT	H	J	L
1 3/16 1 1/4	RFB-103 RFB-104	RFB-103-C RFB-104-C	RFB-103-N RFB-104-N	6.0	2.81	4.00	2.31	2.88	4.07	.06	3/8	1.00	3.50	2.25
1 3/8 1 7/16	RFB-106 RFB-107	RFB-106-C RFB-107-C	RFB-106-N RFB-107-N	8.1	3.06	4.62	2.56	3.50	4.95	.06	1/2	1.00	3.88	2.62
1 1/2 1 5/8 1 11/16	RFB-108 RFB-110 RFB-111	RFB-108-C RFB-110-C RFB-111-C	RFB-108-N RFB-110-N RFB-111-N	12.3	3.50	5.38	2.94	4.12	5.82	.12	1/2	1.19	4.50	2.88
1 3/4 1 15/16 2	RFB-112 RFB-115 RFB-200	RFB-112-C RFB-115-C RFB-200-C	RFB-112-N RFB-115-N RFB-200-N	14.5	3.62	5.62	3.06	4.38	6.19	.12	1/2	1.19	4.75	3.25
2 3/16	RFB-203	RFB-203-C	RFB-203-N	19.0	3.88	6.25	3.25	4.88	6.90	.12	5/8	1.38	5.25	3.62
2 1/4 2 7/16 2 1/2	RFB-204 RFB-207 RFB-208	RFB-204-C RFB-207-C RFB-208-C	RFB-204-N RFB-207-N RFB-208-N	24.0	4.19	6.88	3.56	5.38	7.61	.19	5/8	1.50	5.75	3.94
2 11/16 2 3/4 2 15/16 3	RFB-211 RFB-212 RFB-215 RFB-300	RFB-211-C RFB-212-C RFB-215-C RFB-300-C	RFB-211-N RFB-212-N RFB-215-N RFB-300-N	33.4	4.69	7.75	3.94	6.00	8.48	.19	3/4	1.62	6.50	4.75
3 3/16 3 7/16 3 1/2	RFB-303 RFB-307 RFB-308	RFB-303-C RFB-307-C RFB-308-C	RFB-303-N RFB-307-N RFB-308-N	57.4	5.25	9.25	4.50	7.00	9.90	.25	3/4	1.88	8.00	5.50
3 15/16 4	RFB-315 RFB-400	RFB-315-C RFB-400-C	RFB-315-N RFB-400-N	81.8	6.50	10.25	5.62	7.75	10.96	.25	7/8	2.12	8.88	6.00
4 7/16 4 1/2	RFB-407 RFB-408	RFB-407-C RFB-408-C	RFB-407-N RFB-408-N	110.0	7.00	11.50	6.00	8.75	12.37	.25	1	2.62	9.75	6.50

The RFB series of roller bearing flange units is designed for applications in industrial machinery where heavy loads at low, medium, or relatively high speeds exist. They are ideal for face mounting against vertical or horizontal frames where a minimum amount of machining is required.

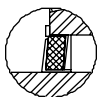

**Felt Seal Standard**  
Positive sealing for low, medium, and high speed operation.

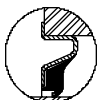

**Single Lip Contact Seal**  
Available on all sizes. Recommended where moisture conditions prevail.

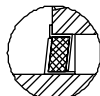

**Hi-Temp Seal**  
Available as an option where operating temperatures are in 250-400° range.

For Replacement Cartridge Insert See Page 120.

For Load Ratings See Page 121.

For Metric Bores, See Page 127.

Installation alignment correction is ± 3 degrees equal to .052" per inch.

(1) Hi-Temp Units are factory assembled-to-order basis.

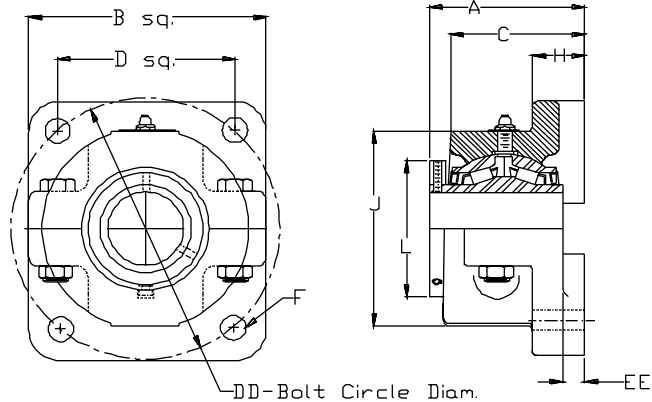
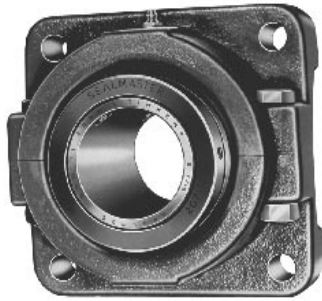

## RFB-A Series Flange Units

SHAFT DIAM. IN.	STANDARD SEAL PART NO.	CONTACT SEAL PART NO.	HI-TEMP (1) SEAL PART NO.	APPROX. WT. IN LBS.	DIMENSIONS IN INCHES									
					A	B	C	D	DD	EE	F BOLT	H	J	L
1 3/16 1 1/4	RFBA-103 RFBA-104	RFBA-103-C RFBA-104-C	RFBA-103-N RFBA-104-N	6.0	2.81	4.00	2.31	2.88	4.07	.44	3/8	1.00	3.50	2.25
1 3/8 1 7/16	RFBA-106 RFBA-107	RFBA-106-C RFBA-107-C	RFBA-106-N RFBA-107-N	8.1	3.06	4.62	2.56	3.50	4.95	.53	1/2	1.00	3.88	2.62
1 1/2 1 5/8 1 11/16	RFBA-108 RFBA-110 RFBA-111	RFBA-108-C RFBA-110-C RFBA-111-C	RFBA-108-N RFBA-110-N RFBA-111-N	12.3	3.50	5.38	2.94	4.12	5.82	.67	1/2	1.19	4.50	2.88
1 3/4 1 15/16 2	RFBA-112 RFBA-115 RFBA-200	RFBA-112-C RFBA-115-C RFBA-200-C	RFBA-112-N RFBA-115-N RFBA-200-N	14.5	3.62	5.62	3.06	4.38	6.19	.67	1/2	1.19	4.75	3.25
2 3/16	RFBA-203	RFBA-203-C	RFBA-203-N	19.0	3.88	6.25	3.25	4.88	6.90	.75	5/8	1.38	5.25	3.62
2 1/4 2 7/16 2 1/2	RFBA-204 RFBA-207 RFBA-208	RFBA-204-C RFBA-207-C RFBA-208-C	RFBA-204-N RFBA-207-N RFBA-208-N	24.0	4.19	6.88	3.56	5.38	7.61	.88	5/8	1.50	5.75	3.94
2 11/16 2 3/4 2 15/16 3	RFBA-211 RFBA-212 RFBA-215 RFBA-300	RFBA-211-C RFBA-212-C RFBA-215-C RFBA-300-C	RFBA-211-N RFBA-212-N RFBA-215-N RFBA-300-N	33.4	4.69	7.75	3.94	6.00	8.48	1.00	3/4	1.62	6.50	4.75
3 3/16 3 7/16 3 1/2	RFBA-303 RFBA-307 RFBA-308	RFBA-303-C RFBA-307-C RFBA-308-C	RFBA-303-N RFBA-307-N RFBA-308-N	57.4	5.25	9.25	4.50	7.00	9.90	1.06	3/4	1.88	8.00	5.50
3 15/16 4	RFBA-315 RFBA-400	RFBA-315-C RFBA-400-C	RFBA-315-N RFBA-400-N	81.8	6.50	10.25	5.62	7.75	10.96	1.25	7/8	2.12	8.88	6.00
4 7/16 4 1/2	RFBA-407 RFBA-408	RFBA-407-C RFBA-408-C	RFBA-407-N RFBA-408-N	110.0	7.00	11.50	6.00	8.75	12.37	1.50	1	2.62	9.75	6.50

See page 114 for seal arrangements. (1) High temp units are factory assembled-to-order basis.

The RFB-A series is similar in design to RFB series, but has single locking collar. These units are designed for applications in industrial machinery where moderate loads at low to medium high speeds exist or where space along the shaft is at a premium.

For Load Ratings, See Page 121.

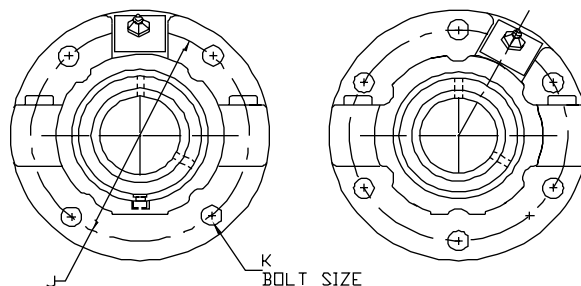
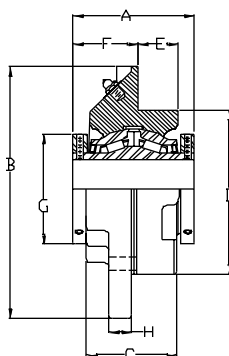

## RFP Series Piloted Flange Units

SHAFT DIAM. IN.	STANDARD SEAL PART NO.	CONTACT SEAL PART NO.	HI-TEMP (1) SEAL PART NO.	APPROX. WT. IN LBS.	DIMENSIONS IN INCHES										
					A	B	C	D (2) +.000 -.002	E	F	G	H	J	K	
1 3/16 1 1/4	RFP-103 RFP-104	RFP-103-C RFP-104-C	RFP-103-N RFP-104-N	5.5	2.75	5.00	1.75	3.375	.88	1.31	2.25	.44	4.12	.38	
1 3/8 1 7/16	RFP-106 RFP-107	RFP-106-C RFP-107-C	RFP-106-N RFP-107-N	6.8	3.00	5.25	2.00	3.625	.94	1.50	2.62	.50	4.38	.38	
1 1/2 1 5/8 1 11/16	RFP-108 RFP-110 RFP-111	RFP-108-C RFP-110-C RFP-111-C	RFP-108-N RFP-110-N RFP-111-N	10.1	3.38	6.12	2.25	4.250	1.12	1.56	2.88	.50	5.12	.44	
1 3/4 1 15/16 2	RFP-112 RFP-115 RFP-200	RFP-112-C RFP-115-C RFP-200-C	RFP-112-N RFP-115-N RFP-200-N	11.6	3.50	6.38	2.31	4.500	1.25	1.56	3.25	.56	5.38	.44	
2 3/16	RFP-203	RFP-203-C	RFP-203-N	14.5	3.75	7.12	2.50	5.000	1.31	1.69	3.62	.56	6.00	.50	
2 1/4 2 7/16 2 1/2	RFP-204 RFP-207 RFP-208	RFP-204-C RFP-207-C RFP-208-C	RFP-204-N RFP-207-N RFP-208-N	19.0	4.00	7.62	2.75	5.500	1.44	1.81	3.94	.62	6.50	.50	
2 11/16 2 3/4 2 15/16 3	RFP-211 RFP-212 RFP-215 RFP-300	RFP-211-C RFP-212-C RFP-215-C RFP-300-C	RFP-211-N RFP-212-N RFP-215-N RFP-300-N	26.7	4.50	8.75	2.88	6.375	1.56	2.00	4.75	.75	7.50	.62	
3 3/16 3 7/16 3 1/2	RFP-303 RFP-307 RFP-308	RFP-303-C RFP-307-C RFP-308-C	RFP-303-N RFP-307-N RFP-308-N	42.6	5.00	10.25	3.38	7.375	1.62	2.44	5.50	.88	8.62	.75	
3 15/16 4	RFP-315 RFP-400	RFP-315-C RFP-400-C	RFP-315-N RFP-400-N	55.2	6.25	10.88	4.38	8.125	2.44	2.69	6.00	.94	9.38	.75	
4 7/16 4 1/2	RFP-407 RFP-408	RFP-407-C RFP-408-C	RFP-407-N RFP-408-N	91.0	6.75	13.50	4.62	10.250	2.38	3.03	6.50	1.00	11.75*	.75	
4 15/16 5	RFP-415 RFP-500	RFP-415-C RFP-500-C	RFP-415-N RFP-500-N	115.0	7.25	14.75	5.38	11.000	2.88	2.97	7.31	1.25	12.75*	.88	

The RFB series of roller bearing flange units is designed for applications in industrial machinery where heavy loads at low, medium, or relatively high speeds exist. They are ideal for face mounting against vertical or horizontal frames where a minimum amount of machining is required.

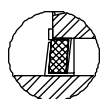

**Felt Seal Standard**  
Positive sealing for low, medium, and high speed operation.



**Single Lip Contact Seal**  
Available on all sizes. Recommended where moisture conditions prevail.

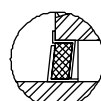

**Hi-Temp Seal**  
Available as an option where operating temperatures are in 250-400° range.

For Replacement Cartridge Insert See Page 120.  
For Load Ratings See Page 121.  
For Metric Bores, See Page 127.

- (1) Hi-Temp Units are factory assembled-to-order basis.
  - (2) Bore of frame should be the "D" dimension shown in table above. +.002", +.005", to assure adequate support of bearing pilot.
- \* 6 Bolt—All others four bolt.

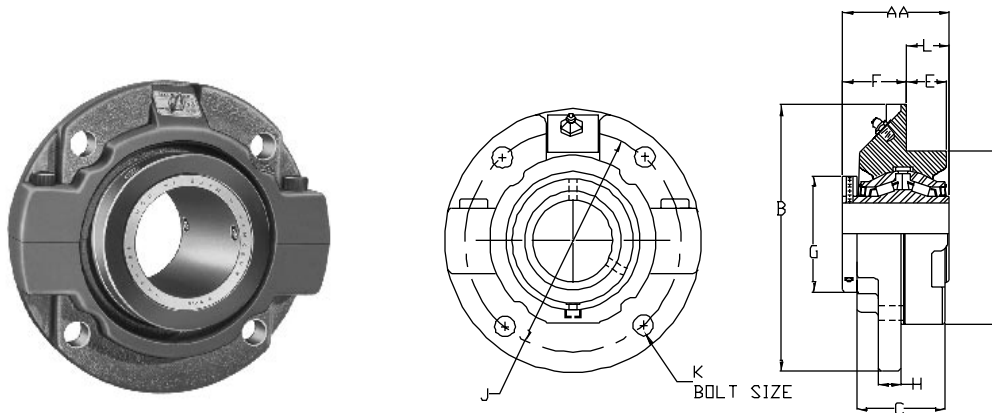

## RFP-A Series Piloted Flange Units

SHAFT DIAM. IN.	STANDARD SEAL	CONTACT SEAL	HI-TEMP (1) SEAL	APPROX. WT. IN LBS.	DIMENSIONS IN INCHES										
	PART NO.	PART NO.	PART NO.		AA	B	C	D (2) +0.002 -0.002	E	F	G	H	J	K	L
1 3/16 1 1/4	RFPA-103 RFPA-104	RFPA-103-C RFPA-104-C	RFPA-103-N RFPA-104-N	5.5	2.37	5.00	1.75	3.375	.88	1.31	2.25	.44	4.12	.38	1.06
1 3/8 1 7/16	RFPA-106 RFPA-107	RFPA-106-C RFPA-107-C	RFPA-106-N RFPA-107-N	6.8	2.53	5.25	2.00	3.625	.94	1.50	2.62	.50	4.38	.38	1.03
1 1/2 1 5/8 1 11/16	RFPA-108 RFPA-110 RFPA-111	RFPA-108-C RFPA-110-C RFPA-111-C	RFPA-108-N RFPA-110-N RFPA-111-N	10.1	2.84	6.12	2.25	4.250	1.12	1.56	2.88	.50	5.12	.44	1.28
1 3/4 1 15/16 2	RFPA-112 RFPA-115 RFPA-200	RFPA-112-C RFPA-115-C RFPA-200-C	RFPA-112-N RFPA-115-N RFPA-200-N	11.6	2.95	6.38	2.31	4.500	1.25	1.56	3.25	.56	5.38	.44	1.39
2 3/16	RFPA-203	RFPA-203-C	RFPA-203-N	14.5	3.12	7.12	2.50	5.000	1.31	1.69	3.62	.56	6.00	.50	1.44
2 1/4 2 7/16 2 1/2	RFPA-204 RFPA-207 RFPA-208	RFPA-204-C RFPA-207-C RFPA-208-C	RFPA-204-N RFPA-207-N RFPA-208-N	19.0	3.31	7.62	2.75	5.500	1.44	1.81	3.94	.62	6.50	.50	1.50
2 11/16 2 3/4 2 15/16 3	RFPA-211 RFPA-212 RFPA-215 RFPA-300	RFPA-211-C RFPA-212-C RFPA-215-C RFPA-300-C	RFPA-211-N RFPA-212-N RFPA-215-N RFPA-300-N	26.7	3.69	8.75	2.88	6.375	1.56	2.00	4.75	.75	7.50	.62	1.69
3 3/16 3 7/16 3 1/2	RFPA-303 RFPA-307 RFPA-308	RFPA-303-C RFPA-307-C RFPA-308-C	RFPA-303-N RFPA-307-N RFPA-308-N	42.6	4.19	10.25	3.38	7.375	1.62	2.44	5.50	.88	8.62	.75	1.75
3 15/16 4	RFPA-315 RFPA-400	RFPA-315-C RFPA-400-C	RFPA-315-N RFPA-400-N	55.2	5.25	10.88	4.38	8.125	2.44	2.69	6.00	.94	9.38	.75	2.56
4 7/16 4 1/2	RFPA-407 RFPA-408	RFPA-407-C RFPA-408-C	RFPA-407-N RFPA-408-N	91.0	5.50	13.50	4.62	10.250	2.38	3.03	6.50	1.00	11.75*	.75	2.47
4 15/16 5	RFPA-415 RFPA-500	RFPA-415-C RFPA-500-C	RFPA-415-N RFPA-500-N	115.0	6.21	14.75	5.38	11.000	2.88	2.97	7.31	1.25	12.75*	.88	3.24

The RFBA series is similar in design to RFP series, but has single locking collar. These units are designed for applications in industrial machinery where moderate loads at low to medium high speeds exist or where space along the shaft is at a premium.

- (1) Hi-Temp Units are factory assembled-to-order basis.
- (2) Bore of frame should be the "D" dimension shown in table above.  
+.002", +.005", to assure adequate support of bearing pilot.
- \* 6 Bolt—All others four bolt.

See page 116 for seal arrangements.  
For Load Ratings, See Page 121.

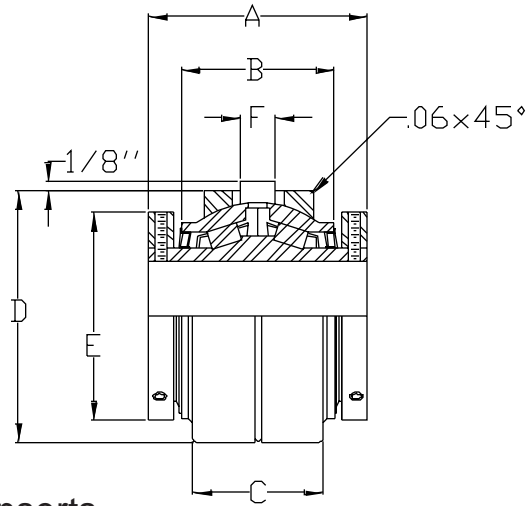

## ERCI Series Cylindrical Cartridge Inserts

SHAFT DIAM. IN.	STANDARD SEAL	CONTACT SEAL	HI-TEMP (1) SEAL	APPROX. WT. IN LBS.	DIMENSIONS IN INCHES					
	PART NO.	PART NO.	PART NO.		A	B	C	D (2) +.000 -.002	E	F
1 3/4 1 15/16 2	ERCI-112 ERCI-115 ERCI-200	ERCI-112-C ERCI-115-C ERCI-200-C	ERCI-112-N ERCI-115-N ERCI-200-N	6.5	3.50	2.10	1.75	3.939	3.25	.25
2 3/16	ERCI-203	ERCI-203-C	ERCI-203-N	7.7	3.75	2.25	1.75	4.439	3.62	.38
2 1/4 2 7/16 2 1/2	ERCI-204 ERCI-207 ERCI-208	ERCI-204-C ERCI-207-C ERCI-208-C	ERCI-204-N ERCI-207-N ERCI-208-N	10.0	4.00	2.38	1.80	4.782	3.94	.38
2 11/16 2 3/4 2 15/16 3	ERCI-211 ERCI-212 ERCI-215 ERCI-300	ERCI-211-C ERCI-212-C ERCI-215-C ERCI-300-C	ERCI-211-N ERCI-212-N ERCI-215-N ERCI-300-N	13.0	4.50	2.50	2.00	5.376	4.75	.38
3 3/16 3 7/16 3 1/2	ERCI-303 ERCI-307 ERCI-308	ERCI-303-C ERCI-307-C ERCI-308-C	ERCI-303-N ERCI-307-N ERCI-308-N	22.0	5.00	3.00	2.25	6.595	5.50	.50
3 15/16 4	ERCI-315 ERCI-400	ERCI-315-C ERCI-400-C	ERCI-315-N ERCI-400-N	30.0	6.25	4.00	3.13	7.189	6.00	.50
4 7/16 4 1/2	ERCI-407 ERCI-408	ERCI-407-C ERCI-408-C	ERCI-407-N ERCI-408-N	38.4	6.75	4.00	3.25	8.001	6.50	.50
4 15/16 5	ERCI-415 ERCI-500	ERCI-415-C ERCI-500-C	ERCI-415-N ERCI-500-N	55.0	7.25	4.50	3.75	9.063	7.31	.50

The ERCI series of steel cylindrical roller bearing cartridge units is designed for mounting in a cylindrical bore for a wide range of general machine applications. Units are equipped with Timken® roller bearings which are factory adjusted, grease lubricated, and sealed. They have full self-aligning capability.

When used as a "fixed" bearing, provision must be made for locating outer ring in housing to prevent lateral movement. Provision for lubrication is recommended utilizing holes in cartridge O. D. located 30° on either side of the alignment pin. Recommended housing bore is nominal, +.002", -.000". ERCI cylindrical cartridge units are replacement cartridges for ERPB expansion type pillow blocks.

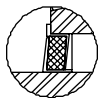

**Felt Seal Standard**  
Positive sealing for low, medium, and high speed operation.

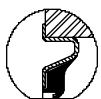

**Single Lip Contact Seal**  
Available on all sizes. Recommended where moisture conditions prevail.

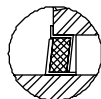

**Hi-Temp Seal**  
Available as an option where operating temperatures are in 250-400° range.

Installation alignment correction is ± 3 degrees equal to .052" per inch.  
For Load Ratings, See Page 121.

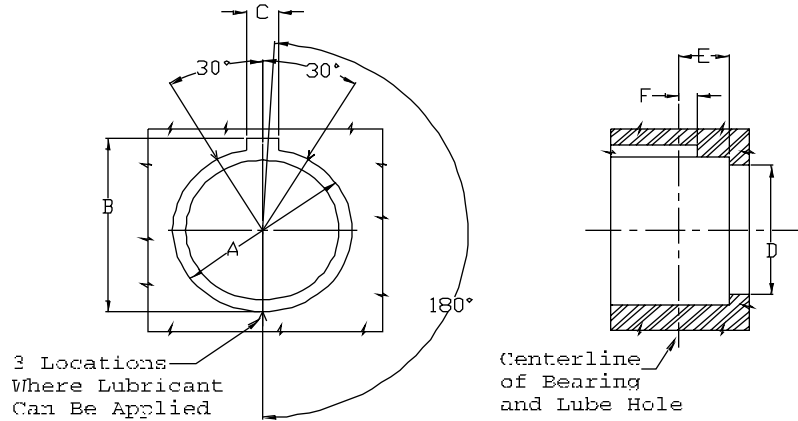

## ERCI Series Housing Bore Dimensions

SHAFT DIAM.	"A" DIM. +.002/-0.00	"B" DIM. +.01/.00	"C" DIM. +.01/-0.00	"D" DIM. ±.01	"E" DIM. ±.01	"F" DIM. MIN. ±.005
1 3/4 1 15/16 2	3.939	4.12	.44	3.63	.97	.25
2 3/16	4.439	4.62	.56	4.00	.97	.38
2 1/4 2 7/16 2 1/2	4.782	5.01	.56	4.38	1.03	.38
2 11/16 2 3/4 2 15/16 3	5.376	5.50	.56	5.12	1.16	.38
3 3/16 3 7/16 3 1/2	6.595	6.89	.75	6.00	1.28	.50
3 15/16 4	7.189	7.46	.75	6.62	1.75	.50
4 7/16 4 1/8	8.001	8.28	.75	7.25	1.81	.50
4 15/16 5	9.063	9.34	.75	8.50	2.06	.50

## TYPICAL HOUSING INSTALLATIONS

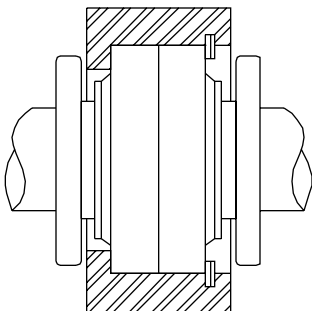

Cartridge Fixed Between  
Shoulder &-Snap Ring

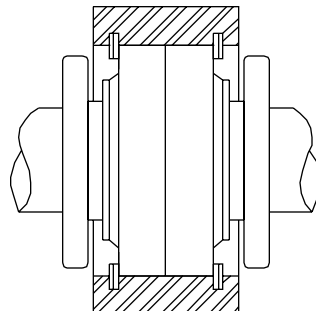

Cartridge Set For Expansion  
And Held Between Snap Rings

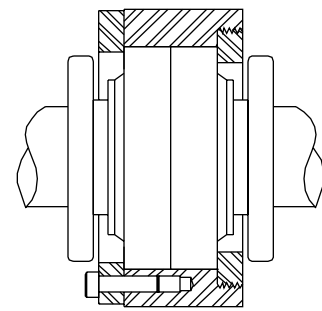

Cartridge Fixed Between Two  
Types of Collars



**RCI Series**  
Double Extension  
Two Locking Collars



**RCIA Series**  
Single Extension  
One Locking Collar



## RCI & RCIA Series Replacement Cartridge Inserts\*

RCI FELT SEAL	CONTACT SEAL	HI-TEMP SEAL	SHAFT DIAM. IN.	APPROX. SHIPPING WEIGHT LBS.	RCIA FELT SEAL	CONTACT SEAL	FELT SEAL
RCI-103	RCI-103-C	†RCI-103-N	1 3/16	2.0	†RCIA-103	†RCIA-103-C	†RCIA-103-N
RCI-104	RCI-104-C	†RCI-104-N	1 1/4	1.9	†RCIA-104	†RCIA-104-C	†RCIA-104-N
RCI-106	RCI-106-C	†RCI-106-N	1 3/8	2.9	†RCIA-106	†RCIA-106-C	†RCIA-106-N
RCI-107	RCI-107-C	†RCI-107-N	1 7/16	2.7	†RCIA-107	†RCIA-107-C	†RCIA-107-N
RCI-108	RCI-108-C	†RCI-108-N	1 1/2	4.5	†RCIA-108	†RCIA-108-C	†RCIA-108-N
RCI-110	RCI-110-C	†RCI-110-N	1 5/8	4.2	†RCIA-110	†RCIA-110-C	†RCIA-110-N
RCI-111	RCI-111-C	†RCI-111-N	1 11/16	4.0	†RCIA-111	†RCIA-111-C	†RCIA-111-N
RCI-112	RCI-112-C	†RCI-112-N	1 3/4	5.3	RCIA-112	RCIA-112-C	RCIA-112-N
RCI-115	RCI-115-C	†RCI-115-N	1 15/16	4.8	RCIA-115	RCIA-115-C	RCIA-115-N
RCI-200	RCI-200-C	†RCI-200-N	2	4.6	RCIA-200	RCIA-200-C	RCIA-200-N
RCI-203	RCI-203-C	†RCI-203-N	2 3/16	6.2	RCIA-203	RCIA-203-C	RCIA-203-N
RCI-204	RCI-204-C	†RCI-204-N	2 1/4	8.4	RCIA-204	RCIA-204-C	RCIA-204-N
RCI-207	RCI-207-C	†RCI-207-N	2 7/16	7.4	RCIA-207	RCIA-207-C	RCIA-207-N
RCI-208	RCI-208-C	†RCI-208-N	2 1/2	7.2	RCIA-208	RCIA-208-C	RCIA-208-N
RCI-211	RCI-211-C	†RCI-211-N	2 11/16	11.5	RCIA-211	RCIA-211-C	RCIA-211-N
RCI-212	RCI-212-C	†RCI-212-N	2 3/4	11.3	RCIA-212	RCIA-212-C	RCIA-212-N
RCI-215	RCI-215-C	†RCI-215-N	2 15/16	10.3	RCIA-215	RCIA-215-C	RCIA-215-N
RCI-300	RCI-300-C	†RCI-300-N	3	10.0	RCIA-300	RCIA-300-C	RCIA-300-N
RCI-303	RCI-303-C	†RCI-303-N	3 3/16	19.6	RCIA-303	RCIA-303-C	RCIA-303-N
RCI-307	RCI-307-C	†RCI-307-N	3 7/16	17.8	RCIA-307	RCIA-307-C	RCIA-307-N
RCI-308	RCI-308-C	†RCI-308-N	3 1/2	17.3	RCIA-308	RCIA-308-C	RCIA-308-N
RCI-315	RCI-315-C	†RCI-315-N	3 15/16	23.1	RCIA-315	RCIA-315-C	RCIA-315-N
RCI-400	RCI-400-C	†RCI-400-N	4	22.6	RCIA-400	†RCIA-400-C	RCIA-400-N
RCI-407	RCI-407-C	†RCI-407-N	4 7/16	30.4	RCIA-407	†RCIA-407-C	RCIA-407-N
RCI-408	RCI-408-C	†RCI-408-N	4 1/2	29.9	RCIA-408	†RCIA-408-C	RCIA-408-N
RCI-415	RCI-415-C	†RCI-415-N	4 15/16	45.6	RCIA-415	†RCIA-415-C	RCIA-415-N
RCI-500	RCI-500-C	†RCI-500-N	5	44.4	RCIA-500	†RCIA-500-C	RCIA-500-N



Felt Seal Standard  
Positive sealing for low, medium, and high speed operation.



Single Lip Contact Seal  
Available on all sizes. Recommended where moisture conditions prevail.



Hi-Temp Seal  
Available as an option where operating temperatures are in 250-400° range.

\* Insert package includes factory lubed, adjusted, and sealed cartridge complete with single or double locking collars.

† Contact Customer Service Center for availability.  
For Load Ratings, See Page 121.

### LOAD RATING TABLES - RPB ROLLER BEARINGS

This chart displays the Sealmaster RPB Roller Bearing's load capacity for a given L10 life, speed, and shaft size. Areas designated by "-" exceed maximum value for standard bearings. Consult Sealmaster Application Engineering for load and speed applications not covered in this table or for operation at high speeds or high loads.

REVOLUTIONS PER MINUTE															
SHAFT SIZE	L10 HOURS	50	100	250	500	750	1000	1250	1500	1750	2000	2500	3000	3500	4000
1 3/16	5000	3360	3360	3142	2552	2260	2073	1939	1836	1753	1684	1575	1491	1424	1368
	10000	3360	3360	2552	2073	1836	1684	1575	1491	1424	1368	1279	1211	1156	1111
	30000	2975	2416	1836	1491	1320	1211	1279	1072	1024	984	920	871	832	902
	50000	2552	2073	1575	1279	1133	1039	1081	920	878	844	789	747	714	763
	100000	2073	1684	1279	1039	920	844	971	747	714	685	641	607	580	685
1 7/16	5000	5376	5376	5028	4084	3616	3317	3104	2937	2804	2694	2520	2386	2278	-
	10000	5376	5376	4084	3317	2937	2694	2521	2386	2278	2188	2047	1938	1850	-
	30000	4760	3866	2937	2386	2112	1938	2048	1716	1638	1574	1472	1394	1331	-
	50000	4084	3317	2520	2047	1812	1662	1732	1472	1406	1350	1263	1196	1142	-
	100000	3317	2694	2047	1662	1472	1350	1555	1196	1142	1097	1026	971	927	-
1 1/2	5000	6934	6934	6485	5268	4664	4279	4000	3789	3617	3475	3250	3077	-	-
	10000	6934	6934	5268	4279	3789	3475	3249	3077	2938	2823	2640	2500	-	-
	30000	6140	4987	3789	3077	2725	2500	2640	2213	2113	2030	1899	1798	-	-
	50000	5268	4279	3250	2640	2338	2144	2231	1899	1813	1742	1629	1542	-	-
	100000	4279	3475	2640	2144	1899	1742	2007	1542	1473	1415	1323	1253	-	-
1 3/4	5000	9114	9114	8524	6923	6130	5624	5259	4979	4754	4568	4272	-	-	-
	10000	9114	9114	6923	5624	4979	4568	4271	4045	3862	3710	3470	-	-	-
	30000	8070	6555	4979	4045	3581	3285	3470	2909	2777	2668	2496	-	-	-
	50000	6923	5624	4272	3470	3072	2818	2934	2496	2383	2289	2141	-	-	-
	100000	5624	4568	3470	2818	2496	2289	2636	2027	1935	1859	1739	-	-	-
2 3/16	5000	9679	9679	9052	7352	6510	5972	5584	5288	5049	4851	4537	-	-	-
	10000	9679	9679	7352	5972	5288	4851	4587	4295	4101	3940	3685	-	-	-
	30000	8570	6961	5288	4295	3803	3489	3684	3089	2950	2834	2650	-	-	-
	50000	7352	5972	4538	3585	3263	2993	3115	2650	2530	2431	2274	-	-	-
	100000	5972	4851	3685	2993	2650	2431	2799	2153	2055	1975	1847	-	-	-
2 1/4	5000	10198	10198	9538	7747	6860	6293	5940	5572	5320	5111	-	-	-	-
	10000	10198	10198	7747	6293	5572	5111	4824	4526	4321	4152	-	-	-	-
	30000	9030	7335	5572	4526	4007	3676	3918	3255	3108	2986	-	-	-	-
	50000	7747	6293	4780	3883	3438	3154	3313	2793	2666	2562	-	-	-	-
	100000	6293	5111	3883	3154	2793	2562	2977	2268	2166	2081	-	-	-	-
2 11/16	5000	10876	10876	10171	8262	7316	6711	6279	5942	5674	-	-	-	-	-
	10000	10876	10876	8262	6711	5942	5451	5100	4826	4608	-	-	-	-	-
	30000	9630	7822	5942	4826	4274	3920	4143	3471	3314	-	-	-	-	-
	50000	8262	6711	5098	4141	3666	3363	3502	2978	2843	-	-	-	-	-
	100000	6711	5451	4141	3363	2978	2732	3147	2419	2310	-	-	-	-	-
3 3/16	5000	17302	17302	16181	13143	11638	10676	9983	9453	-	-	-	-	-	-
	10000	17302	17302	13143	10676	9453	8671	8109	7678	-	-	-	-	-	-
	30000	15320	12444	9453	7678	6799	6237	6587	5522	-	-	-	-	-	-
	50000	13143	10676	8110	6587	5833	5351	5569	4738	-	-	-	-	-	-
	100000	10676	8671	6587	5351	4738	4346	5004	3848	-	-	-	-	-	-
3 15/16	5000	23694	23694	22159	17999	15938	14620	13673	-	-	-	-	-	-	-
	10000	23694	23694	17999	14620	12945	11875	11106	-	-	-	-	-	-	-
	30000	20980	17041	12945	10515	9311	8541	9021	-	-	-	-	-	-	-
	50000	17999	14620	11106	9021	7988	7327	7627	-	-	-	-	-	-	-
	100000	14620	11875	9021	7327	6488	5952	6852	-	-	-	-	-	-	-
4 7/16	5000	29081	29081	27198	22091	19561	17944	16783	-	-	-	-	-	-	-
	10000	29081	29081	22091	17944	15889	14575	13632	-	-	-	-	-	-	-
	30000	25750	20915	15889	12906	11427	10483	10072	-	-	-	-	-	-	-
	50000	22091	17944	13631	11072	9804	8993	9362	-	-	-	-	-	-	-
	100000	17944	14575	11072	8993	7963	7305	8412	-	-	-	-	-	-	-
4 15/16	5000	40114	40114	37517	30473	26983	24752	-	-	-	-	-	-	-	-
	10000	40114	40114	30473	24752	21917	20105	-	-	-	-	-	-	-	-
	30000	35520	28851	21917	17802	15763	14460	-	-	-	-	-	-	-	-
	50000	30473	24752	18803	15273	13524	12405	-	-	-	-	-	-	-	-
	100000	24752	20105	15273	12405	10985	10076	-	-	-	-	-	-	-	-

For high load-high speed applications, see page 204.  
 For Bearing Selection and Engineering, see page 176.



# TOUGH AS THEY COME!

## Corrosion-Resistant Bearings

All RPB Series Pillow Block, Flange and Piloted Flange Units can be provided with “CR” housings to resist corrosion in many difficult environments. RPB-CR bearings feature a corrosion-resistant matrix with a fluoropolymer rich surface on a molecular binder layer that provides significant application advantages in harsh atmospheres:

- Excellent corrosion-resistance.
- Excellent weathering resistance.
- Hard (Matrix) polymer resists abrasion.
- Molecular binder resists peeling, etc.
- Standard silver color blends well with other equipment.
- A wide variety of other colors available on special order.
- Fluoropolymer means “Non-Stick”.

## All The Longer Life Features... Plus A Corrosion-Resistant Polymer Coating

- Split housing, entirely polymer coated, including bore.
- Polymer coated Locking Collars.
- Polymer coated Cap bolts.

### Other Components:

- Stainless Steel Grease Fitting.
- Stainless Steel Washers.
- Standard Contact Seal.
- Black Oxide Outer Race.
- Standard Setscrews.

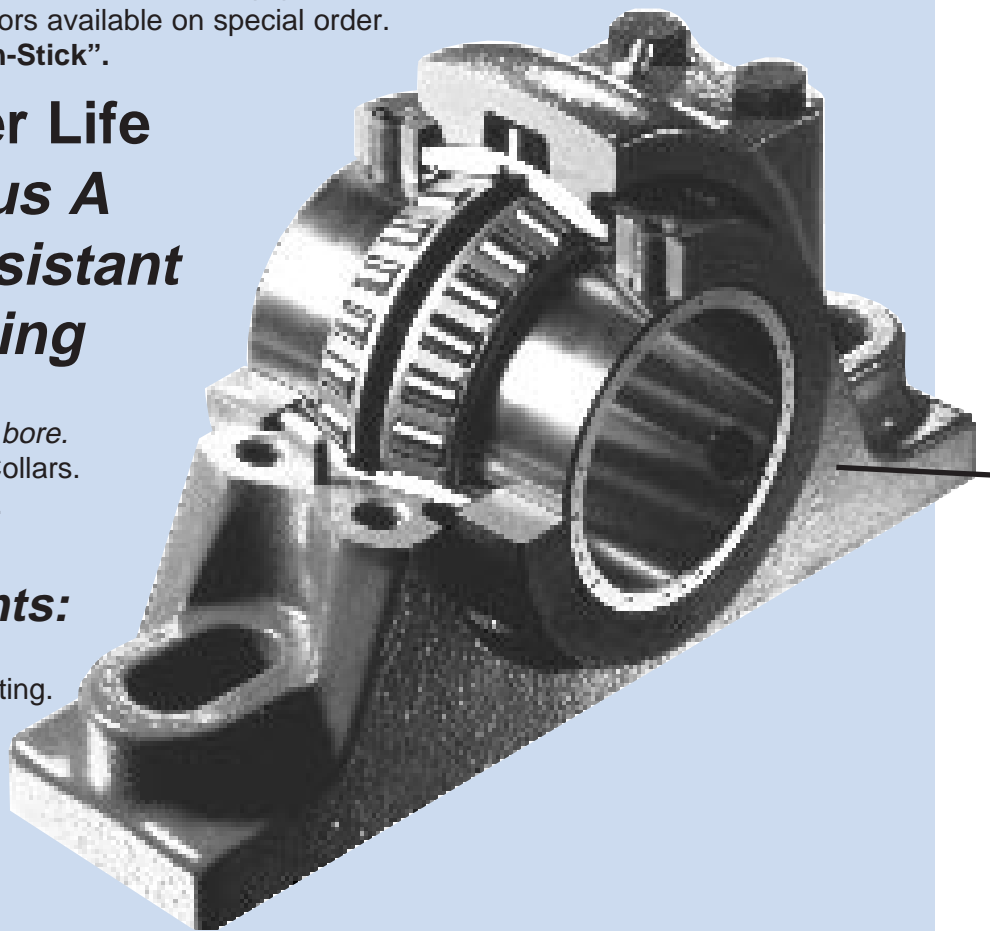

For more information on wet environments, see applications section, page 136.

## SEALMASTER Corrosion-Resistant Mounted Roller Bearings Take On The Tough Applications...

*We begin with the best...* and then improve the design to the most demanding specific services.

The RPB Series Bearings are used in applications where they may be subjected to moisture, corrosive and abrasive atmosphere. Typical applications include:

- Food Processing Equipment.
- Chemical Processing Plants.
- Rubber and Plastic Plants.
- Pulp and Paper Mills.
- Marine and Naval Applications.
- Waste Water Treatment Facilities.
- Bulk Material Handling.

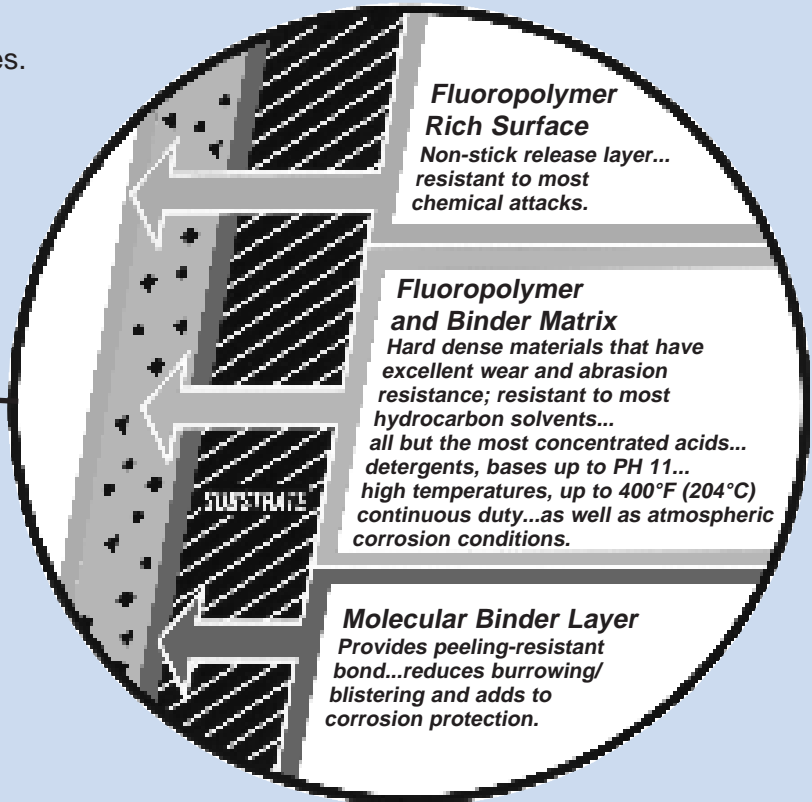

**How To Specify:**

Sealmaster RPB-CR Units are identified on the metal nametag. To specify, add "CR" to the basic part number: "RPB215-2CR"

**UNIQUE...UNCHALLENGED...THE UNDISPUTED LEADER  
IN QUALITY, VALUE-ADDED ADVANTAGES  
AND CUSTOM DESIGNS**

# TOUGH AS THEY COME!

## SEALMASTER RPB-AH *Air Handling* Roller Bearings... *With Enhanced Performance... for the World-Wide HVAC Industry...*

**Roller bearing units for HVAC applications are subjected to a number of unique challenges that include:**

1. Running at *higher* operating speeds.
2. Exposure to *vibration*.
3. Running with *low* noise levels.
4. Mounting on fan frames that have reduced *structural* mass.

SEALMASTER RPB-AH tapered roller bearings units are ***specially-designed with engineering features that address each of these challenges***, and offer overall enhanced performance in air handling services. Here are several reasons why...

**HIGH LOAD CAPACITIES...** RPB-AH Tapered roller bearings offer both high radial as well as high thrust load capacities, or any combination of the two. Spherical roller bearings, on the other hand, are *not* known for their thrust capacity, and are generally not selected/specified for vertical shaft applications which are often encountered in HVAC.

### **PINNED OUTER RACE PREVENTS ITS ROTATION...**

The RPB-AH bearing has a self-aligning capability of  $\pm 3^\circ$ . This design is similar in concept to the proven SEALMASTER ball bearing units which utilize a spherical O.D. insert mounted in a spherical I.D. cast iron housing, equipped with a locating pin. This anti-rotation pin prevents outer race rotation under load and does not limit the RPB-AH self-aligning capability. The extensions on the cartridge inserts limit misalignment to  $\pm 3^\circ$ .

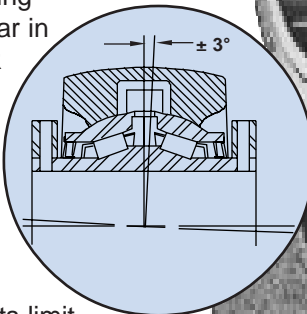

**CUSTOM FIT-UP...** Sealmaster engineers have developed a custom fit-up between the bearing cartridge O.D. and the bearing housing specifically for air handling applications. This fit is looser than standard which provides lighter misalignment torque. Fan frames are generally light weight which may deflect before the bearing insert adjusts for misalignment in standard units. This special feature also allows full roller contact with the races and reduces roller edge loading in the bearing.

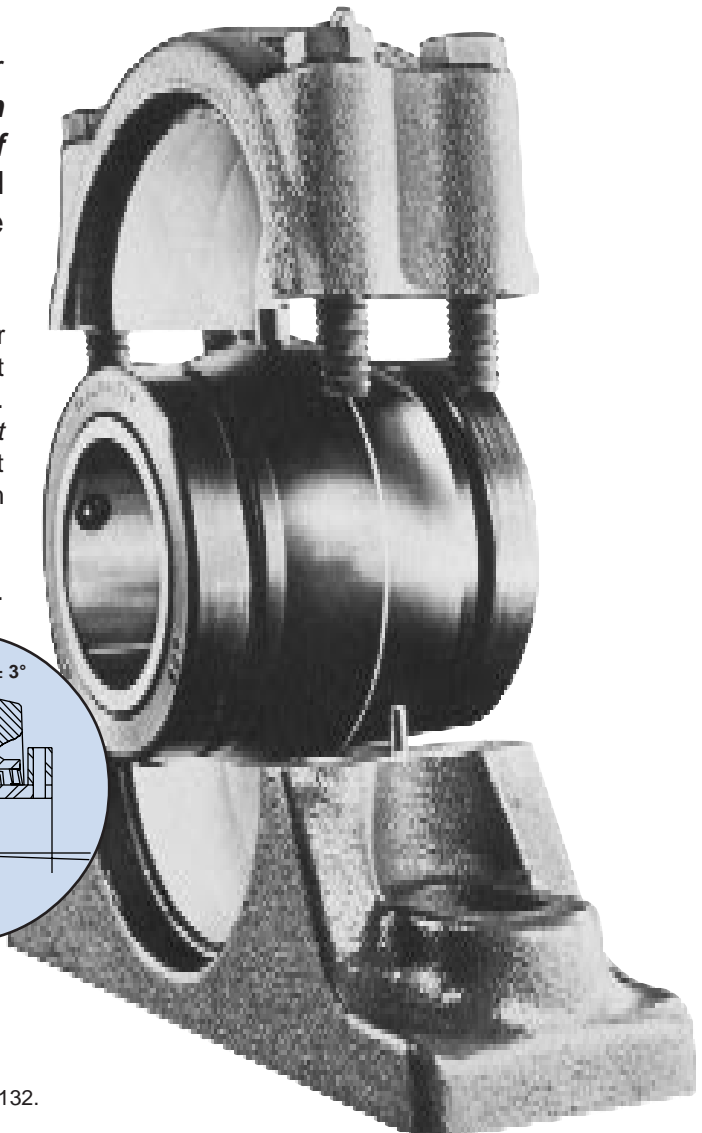

For more information on air handling, see applications section, page 132.

**DURABLE CAST IRON SPLIT HOUSING** - Compact split housing provides quickest replacement of bearing inserts, reduced downtime and replacement costs.

**PATENTED FELT LABYRINTH SEALS** - Proven design directs contaminants away from sealing surfaces, provides a tight fit to exclude foreign material; once grease permeates the felt there's a lower coefficient of friction ( or reduced drag), less heat generation, extended operating life.

**EXTENDED INNER RACES** - With double locking collars provides a more secure locking system, more holding power and greater stability on the shaft.

## MORE CHOICES... MORE STYLES AND SIZES

### Air Handling - Self Aligning Roller Bearing Units

SHAFT SIZE INCH	HOUSING SIZE RANGE SIZE	2 BOLT PILLOW BLOCKS		4 BOLT PILLOW BLOCKS			FLANGE BLOCKS PILOTED FLANGES				MAX SPEEDS**
		RPB	RPB-A DRPB DRPB-A	RPB RPBXT	RPB-A	DRPB DRPB-A	RFB	RFB-A	RFP	RFP-A	
1 3/16 - 1 1/4	103/104	■	-	-	-	-	■	-	■	-	4000
1 3/8 - 1 7/16	106/107	■	-	-	-	-	■	-	■	-	3500
1 1/2 - 1 11/16	108/111	■	■	-	-	-	■	-	■	-	3000
1 3/4 - 2	112/200	■	■	-	-	-	■	■	■	■	2500
2 3/16	203	■	■	■	■	-	■	■	■	■	2500
2 1/4 - 2 1/2	204/208	■	■	■	■	-	■	■	■	■	2000
2 11/16 - 3	211/300	■	■	■	■	-	■	■	■	■	1750
3 3/16 - 3 1/2	303/308	■	■	■	■	-	■	■	■	■	1500
3 15/16 - 4	315/400	-	-	■	■	■	■	-	■	■	1250
4 7/16 - 4 1/2	407/408	-	-	■	■	-	-	-	■	■	1250
4 15/16 - 5	415/500	-	-	■	-	-	-	-	■	-	1000
SEE PAGE FOR SPECIFICATIONS		104	105,107,108	104,111	105	107,108	114	115	116	117	

n Available as Air Handling Units.

Replacement Cartridge inserts, see page 120.

\*\*HVAC applications are normally lightly loaded but may require higher speed capability. For these applications consult Sealmaster Engineering for assistance.

#### OTHER OPTIONS:

- **EXPANSION BEARINGS** - Type ERPB-AH  
Expansion bearings are available on request.
- **HIGH TEMPERATURE OPERATIONS** - Standard bearings can be modified for operation at higher temperatures.

For more details on full range of features and benefits, refer to pages 98-103.

#### NAMEPLATE IDENTIFICATION

RPB-AH Air Handling units are identified with a special SEALMASTER metal nameplate indicating that they are equipped with the special housing fit and are custom engineered for HVAC Air Handling applications.

#### HOW TO SPECIFY:

SEALMASTER RPB-AH Air Handling units are clearly identified on the special metal nameplate  
- to specify, add the "AH" to the basic part number:  
"RPB-207-2AH"



# TOUGH AS THEY COME!

## SEALMASTER RPB-M Series Metric Bore Bearings

The RPB-M Series Metric bore bearing is available in the full range of sizes and various mounted bearing styles as shown in the Table on the opposite page. These metric bearings have the full range of features and benefits of the RPB Series self-aligning bearings described in detail on pages 98-103.

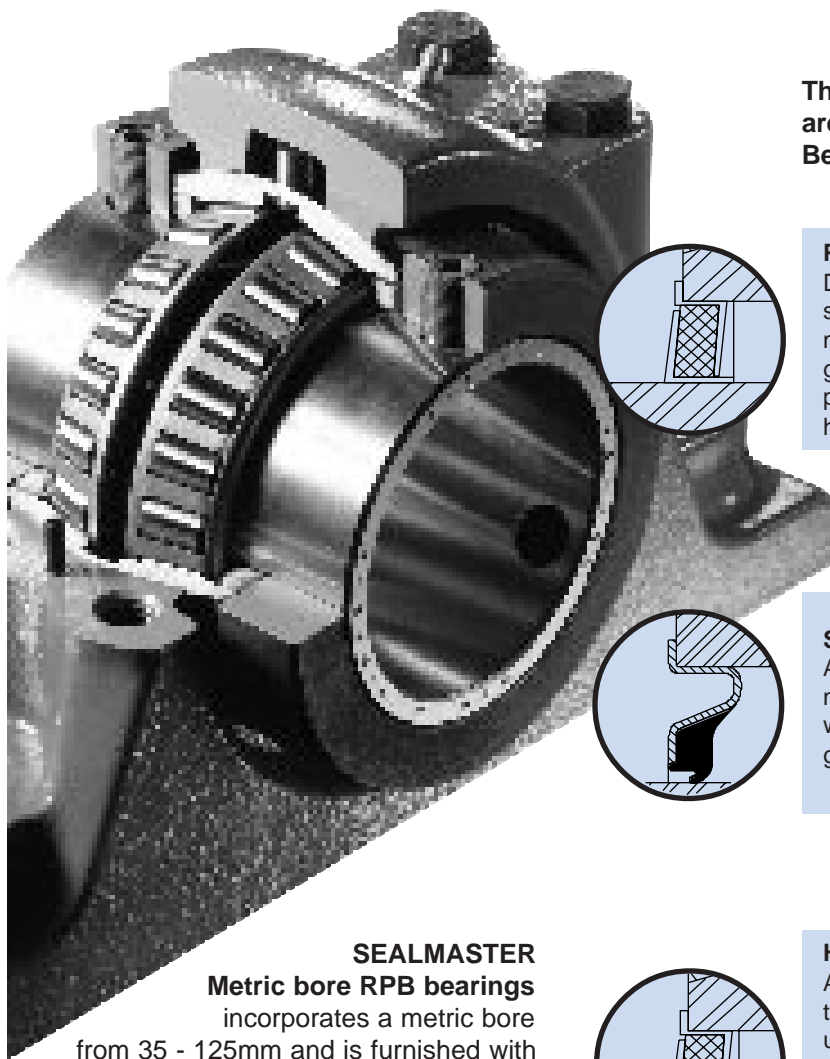

**SEALMASTER**  
Metric bore RPB bearings incorporate a metric bore from 35 - 125mm and is furnished with metric setscrews. All other components and hardware are standard.

Three basic sealing arrangements are offered for the RPB-M Metric Bore Bearing...

### Patented Felt Labyrinth Seal...

Directs contaminants away from the sealing surfaces... provides a tight fit to exclude foreign material... has less drag (friction) and less heat generation than radial lip contact seals; provides positive sealing for low, medium, and high speed operation.

### Single Lip Contact Seal...

Available in all sizes... recommended where moisture conditions prevail... functions well in wet and dirty environments up to 250°F... has good chemical resistance properties.

### High Temperature Seal...

Available extra-cost option where operating temperatures are in the 250 - 400°F range; units with these sealing arrangements are prelubricated at the factory with a special high temperature synthetic lubricant which is normally satisfactory for the temperature range of -40°F to +400°F.

## METRIC BORE Self-Aligning Roller Bearing Units

SHAFT SIZE METRIC	SHAFT SIZE RANGE (INCH)	HOUSING SIZE RANGE (INCH)	2 BOLT PILLOW BLOCKS				4 BOLT PILLOW BLOCKS					FLANGE BLOCKS PILOTTED FLANGE CYLINDRICAL CARTRIDGE INSERTS				
			RPB	RPB-A	ERP DRPB DRPB-A EDPB-A	SPB	RPB RPBXT ERPXT	RPB-A	ERP	DRPB DRPB-A EDPB EDPB-A	SPB	RFB	RFB-A	RFP	RFP-A	ERC
35	1 3/8 - 1 7/16	106/107	■	-	-	-	-	-	-	-	-	■	-	■	-	-
40	1 1/2 - 1 11/16	108/111	■	-	-	■	-	-	-	-	-	■	-	■	-	-
45	1 3/4 - 2	112/200	■	■	■	■	-	-	-	-	-	■	■	■	■	■
50	1 3/4 - 2	112/200	■	■	■	■	-	-	-	-	-	■	■	■	■	■
55	2 3/16	203	■	■	■	■	-	-	-	-	-	■	■	■	■	■
60	2 1/4 - 2 1/2	204/208	■	■	■	■	■	■	-	-	-	■	■	■	■	■
65	2 1/4 - 2 1/2	204/208	■	■	■	■	■	■	-	-	-	■	■	■	■	■
70	2 11/16 - 3	211/300	■	■	■	■	■	■	-	-	-	■	■	■	■	■
75	2 11/16 - 3	211/300	■	■	■	■	■	■	-	-	-	■	■	■	■	■
80	3 3/16 - 3 1/2	303/308	■	■	■	■	■	■	-	-	-	■	■	■	■	■
85	3 3/16 - 3 1/2	303/308	■	■	■	■	■	■	-	-	-	■	■	■	■	■
90	3 3/16 - 3 1/2	303/308	■	■	■	■	■	■	-	-	-	■	■	■	■	■
95	3 3/16 - 3 1/2	303/308	■	■	■	■	■	■	-	-	-	■	■	■	■	■
100	3 15/16 - 4	315/400	-	-	-	-	■	■	■	■	■	■	■	■	■	■
105	3 15/16 - 4	315/400	-	-	-	-	■	■	■	■	■	■	■	■	■	■
110	4 7/16 - 4 1/2	407/408	-	-	-	-	■	-	■	-	■	-	-	■	-	■
115	4 7/16 - 4 1/2	407/408	-	-	-	-	■	-	■	-	■	-	-	■	-	■
120	4 15/16 - 5	415/500	-	-	-	-	■	-	■	-	■	-	-	■	-	■
125	4 15/16 - 5	415/500	-	-	-	-	■	-	■	-	■	-	-	■	-	■
See Page For Mounting Dimensions			104	105	106,107,108	112	104,111	105	106	107,108	112	114	115	116	117	118,119

Available as metric bore units, including metric setscrews. To order: Add "M" to part number. Example: RPB-65M-C2

## RCI-M & RCIA-M Replacement Cartridge Units

RCI-M SERIES				RCIA-M SERIES			
BORE SIZE	FELT SEAL	CONTACT SEAL	HI-TEMP SEAL	BORE SIZE	FELT SEAL	CONTACT SEAL	HI-TEMP SEAL
35	RCI-35M	RCI35M-C	RCI35M-N	35	RCIA-35M	RCIA35M-C	RCIA35M-N
40	RCI-40M	RCI40M-C	RCI40M-N	40	RCIA-40M	RCIA40M-C	RCIA40M-N
45	RCI-45M	RCI45M-C	RCI45M-N	45	RCIA-45M	RCIA45M-C	RCIA45M-N
50	RCI-50M	RCI50M-C	RCI50M-N	50	RCIA-50M	RCIA50M-C	RCIA50M-N
55	RCI-55M	RCI55M-C	RCI55M-N	55	RCIA-55M	RCIA55M-C	RCIA55M-N
60	RCI-60M	RCI60M-C	RCI60M-N	60	RCIA-60M	RCIA60M-C	RCIA60M-N
65	RCI-65M	RCI65M-C	RCI65M-N	65	RCIA-65M	RCIA65M-C	RCIA65M-N
70	RCI-70M	RCI70M-C	RCI70M-N	70	RCIA-70M	RCIA70M-C	RCIA70M-N
75	RCI-75M	RCI75M-C	RCI75M-N	75	RCIA-75M	RCIA75M-C	RCIA75M-N
80	RCI-80M	RCI80M-C	RCI80M-N	80	RCIA-80M	RCIA80M-C	RCIA80M-N
85	RCI-85M	RCI85M-C	RCI85M-N	85	RCIA-85M	RCIA85M-C	RCIA85M-N
90	RCI-90M	RCI90M-C	RCI90M-N	90	RCIA-90M	RCIA90M-C	RCIA90M-N
95	RCI-95M	RCI95M-C	RCI95M-N	95	RCIA-95M	RCIA95M-C	RCIA95M-N
100	RCI-100M	RCI100M-C	RCI100M-N	100	RCIA-100M	RCIA100M-C	RCIA100M-N
105	RCI-105M	RCI105M-C	RCI105M-N	105	RCIA-105M	RCIA105M-C	RCIA105M-N
110	RCI-110M	RCI110M-C	RCI110M-N	110	RCIA-110M	RCIA110M-C	RCIA110M-N
115	RCI-115M	RCI115M-C	RCI115M-N	115	RCIA-115M	RCIA115M-C	RCIA115M-N
120	RCI-120M	RCI120M-C	RCI120M-N	120	RCIA-120M	RCIA120M-C	RCIA120M-N
125	RCI-125M	RCI125M-C	RCI125M-N	125	RCIA-125M	RCIA125M-C	RCIA125M-N

\* Insert package includes factory lubed, adjusted, and sealed cartridge complete with single or double locking collars.



## MODIFICATION AND SPECIAL CAPABILITIES

**HIGH TEMPERATURE** ..... Pages 130-131



**AIR HANDLING** ..... Pages 132-133

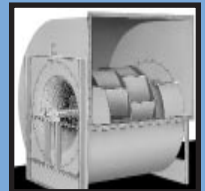

**CONSTRUCTION** ..... Pages 134-135



**WET ENVIRONMENTS** ..... Pages 136-137

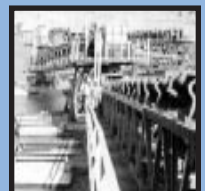

**AGGREGATE/MINING** ..... Pages 138-139



**ECCENTRIC DRIVES** ..... Pages 140-141

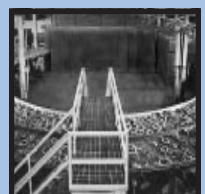

**MIXERS** ..... Pages 142-143





## HIGH TEMPERATURE...

High temperature bearings are found in a broad range of industries. Temperature changes throughout the mounted bearings and shaft system impact the molecular structure of the materials causing expansion and contraction. Also, bearing components such as seals, grease, retainers, races, balls, etc., are affected by the high temperature and may require design modifications to optimize bearing performance.

**Key Concerns...** include effects on material and shaft expansion ranges.

Sealmaster bearings are frequently specified for:

- Industrial Furnaces.
- Bakery Ovens.
- Heat Treat Equipment.
- Incinerators.
- Drying Ovens.
- Fans and Blowers.

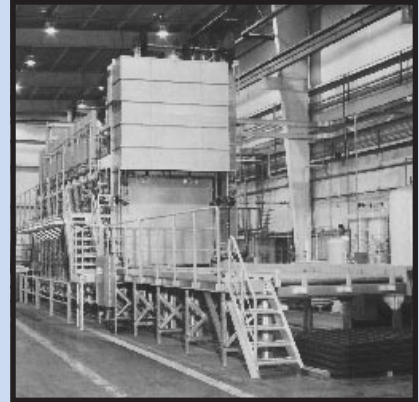

**MOST BEARINGS REQUIRE MORE THAN ONE COMPONENT MODIFICATION TO INCREASE ITS EFFECTIVE OPERATING TEMPERATURE LEVEL. SEALMASTER BEARINGS CAN BE MODIFIED TO OPERATE AT UP TO 375°F.**

## GOLD LINE SOLUTIONS FOR HIGH TEMPERATURE APPLICATIONS.

### Material Temperature Ranges:

#### **Seals...**

**BALL** - Sealmaster Gold Line Ball Bearings have a variety of special high temperature labyrinth and annular contact sealing options available per request. The most frequently used high temperature seals on ball bearings are the Nomex seal design (similar to the standard felt seal), HeatGard Seal (silicon fiberglass contact), or HeatGard Ultra Seal (spring loaded FKM oil seals). *Refer to the seal section found on page 188.*

**ROLLER** - Sealmaster RPB Bearings offer the high temperature Nomex seal design (similar to the felt seal).

#### **Lubrication...**

Sealmaster offers a wide selection of high temperature lubricants formulated to specifically meet specific application conditions. Relubrication frequency may need to be increased to ensure adequate lubrication is maintained.

#### **Retainer...**

**BALL** - The optional Brass Land riding retainer provides a low coefficient of material expansion and is able to withstand elevated temperatures.

**ROLLER** - Metal cage is standard with all Sealmaster Gold Tapered Roller Bearings.

#### **Races and Balls...**

Sealmaster high quality bearing steel extends the maximum effective operating temperature to 375°F.

### Material Expansion:

#### **Internal Clearances...**

Individual bearing components may expand due to wide temperature changes. This condition can cause preloading or bearing seizing. By adjusting internal clearances in the manufacturing process, bearings can be customized to function in specific high temperature applications.

**BALL** - The application's temperature changes physically dictate the amount of clearance required. Sealmaster's extensive experience with high temperature applications have resulted in six unique and proprietary specifications for diametral clearance.

**ROLLER** - The standard Roller Bearing design has the inherent ability to accommodate expansion and contraction of bearing materials. *For more information on Bearing Clearances, see page 193.*

#### **Shaft Expansion...**

**BALL** - Sealmaster Ball Bearings handle shaft expansion through the use of an external insert expansion ring (AR, EMP) or the use of a unique half-dog set screw and lock wire arrangement. Refer to the Sealmaster standard Gold Line expansion ball bearing unit sizes for maximum allowable shaft growth. When shaft expansion requirements exceed these standard specifications, an alternate method is shaft slotting combined with the use of a special half-dog set screw and lock wire arrangement. *Contact Sealmaster Applications engineering for information regarding this option.*

**ROLLER** - Sealmaster Gold Line Tapered Roller Bearings are also offered with cylindrical insert cartridges (ERCI) that can move axially with shaft lengthening. *Refer to the expansion roller bearing unit pages for exact expansion specifications.*

**Contact application engineering with your application parameters for exact bearing selection (630-898-9620).**

# STANDARD & CUSTOM SOLUTIONS FOR HIGH TEMPERATURE APPLICATIONS

GOOD AS  
GOLD...  
NO EQUAL!

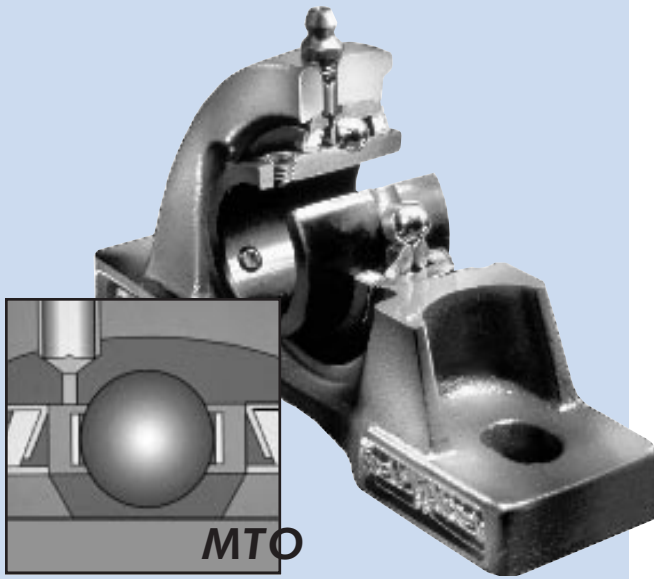

**MTO**

Larger Diametral Clearances



**STD**

Expansion Ball Bearings



**MTO**

Brass Retainer



**MTO**

Half-dog set screw & wire



**MTO**

HeatGard Seal



**MTO**

Nomex Seals



**MTO**

HeatGard Ultra Seals

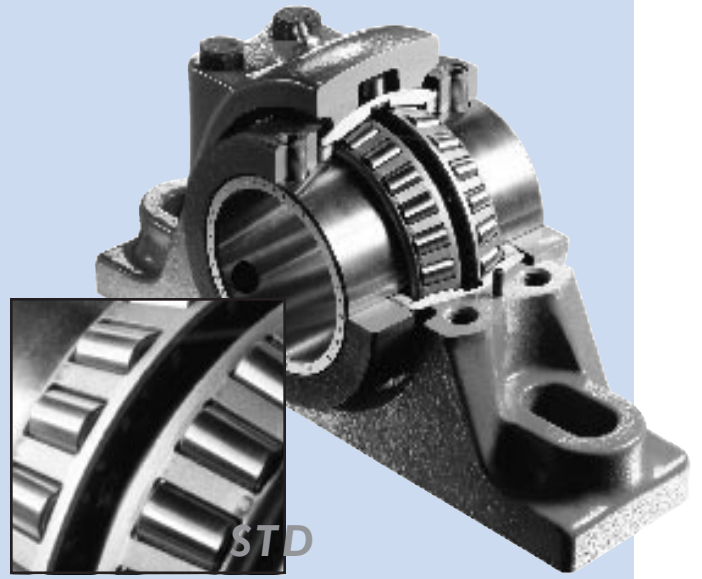

**STD**

Metal Cage



**STD**

Expansion Roller Bearings



**MTO**

Nomex Seals

## See Our...

Standard High Temperature Gold Line Furnace Bearings in the Ball Bearing section on pages 90 & 91.

Note: **MTO** (Made To Order), **STD** (Standard)

# SEALMASTER® APPLICATIONS...

## AIR HANDLING...

Sealmaster Gold Line Bearings are used in Air Handling Applications more than any other type of equipment. They are found in a wide variety of industries including Heating, Ventilation, and Cooling (HVAC) equipment and industrial blowers. Sealmaster bearings have been extremely effective in air handling applications for over 50 years because of the cohesive interplay of Gold Line design features that satisfy many needs of this industry. Air Handling equipment runs at relatively high speeds with high frequency vibration and ordinarily requires quiet bearing operation. Bearings are frequently mounted on light weight frames which can deform during bearing installation. In industrial blower and material handling applications, bearings are often subjected to intermittent shock loads. Energy consumption is also a growing issue in the air handling industry.

**Key Concerns...** are high speed, vibration, noise, frame structures, and energy efficiency.

### GOLD LINE SOLUTIONS FOR AIR HANDLING APPLICATIONS.

#### Operating Conditions:

##### **Misalignment...**

The Sealmaster misalignment capabilities,  $\pm 2^\circ$  on ball and,  $\pm 3^\circ$  roller bearings overcome static alignment problems associated with the installation of mounted bearings on air handling equipment.

##### **Housing Fits...**

Sealmaster increases useful bearing life by incorporating a special air handling fit between the bearing insert/cartridge and the housing that allows the bearing to properly self-align when mounted on lightweight frame structures, without causing frame deflection.

##### **Noise Test...**

During Sealmaster's Ball Bearing manufacturing process, an extra noise test check point is added to identify those bearings that meet the exacting noise level needs of the air handling industry. Sealmaster also performs a honing operation after grinding to further polish the surface finish for quiet operation.

##### **Vertical Mounting...**

Sealmaster special "Rainshield" protective cover, available on certain Mounted Ball Bearings, is often specified on vertical shaft applications where condensation and water tends to travel down the shaft and cascade over the bearing. The special flinger design repels moisture build up through rotating motion or centrifugal force. Ask Sealmaster Application engineers about the S2100 Series "Rainshield" Bearings.

##### **Label Identification...**

**Ball** - AC/NT bearing units are labeled with a metal nameplate riveted into the housing that indicates that the unit is a Sealmaster Air Handling Unit.

**Roller** - Sealmaster RPB-AH Air Handling units (see page 125) are identified with a special **Sealmaster metal nameplate** indicating that they are equipped with the special housing fit and custom engineered for HVAC Air Handling applications.

#### High Speed and Vibration:

##### **Locking Mechanism...**

Often during high speed operation, any eccentricity resonates throughout the air handling system. Inner ring roundness is critical to smooth operation and longer useful bearing life. Sealmaster's balanced 3-point contact setscrew shaft lock system has been field tested and technically studied to provide longer useful bearing life. Double sided set screw shaft locking is standard on roller bearings and also available on medium duty ball bearings using four set screws to hold the bearing to the shaft and is recommended for high speed air handling applications. (See page 49).

**Ball** - Sealmaster Gold Line standard wide inner ring combined with our diamond faceted precision ground setscrews and zone hardened ball path all work together to increase shaft stability and improve our shaft lock ability during the most severe vibrating conditions.

**For our most concentric locking available in a mounted ball bearing, see the SKWEZLOC Section on page 64.**

##### **Locking Pin...**

The locking pin design significantly lessens the likelihood of outer ring rotation that could compromise the integrity of the lubrication system and contribute to corrosive fretting between the outer race and housing.

#### Efficiency:

##### **Seals...**

Sealmaster's field proven felt lined labyrinth seals are ideally suited for air handling energy concerns. The labyrinth construction has an inherent low coefficient of friction between the metal flingers and the filtering material. Standard breakaway and running torques are significantly lower than contact seal designs. Sealmaster labyrinth seals can be modified to provide even lower break away and running torque values.

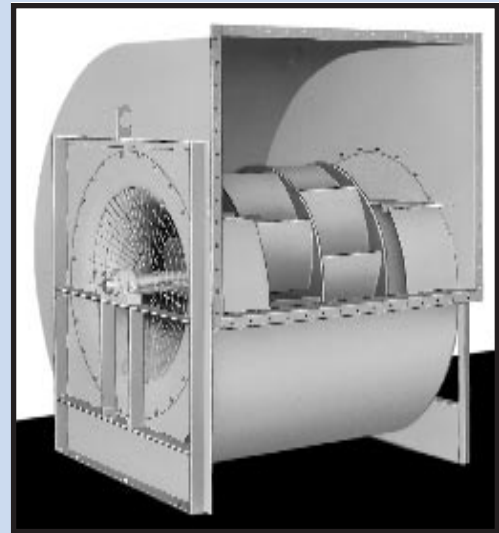

# STANDARD & CUSTOM SOLUTIONS FOR AIR HANDLING APPLICATIONS

GOOD AS GOLD...  
NO EQUAL!

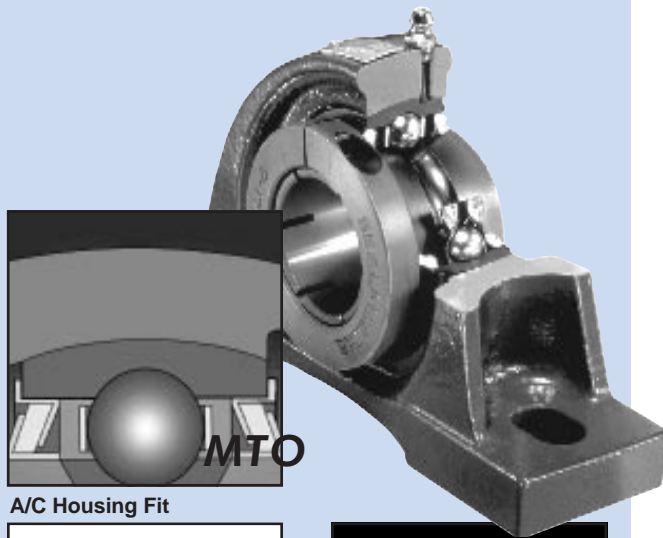

A/C Housing Fit

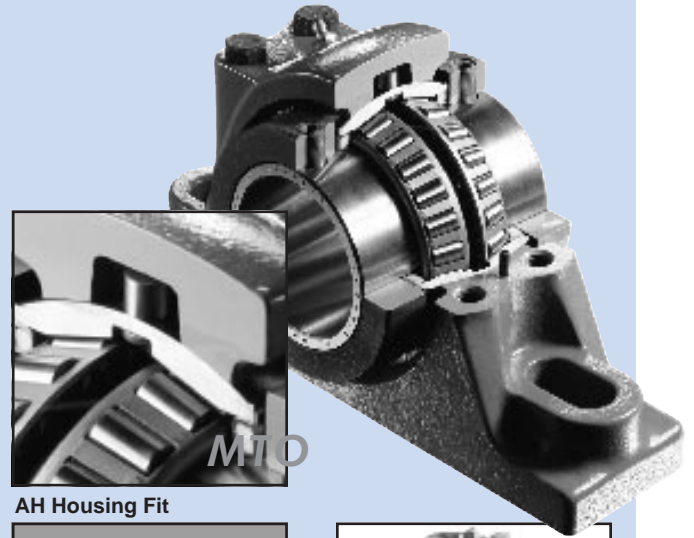

AH Housing Fit



Wide Inner Ring



Solid Base Housing

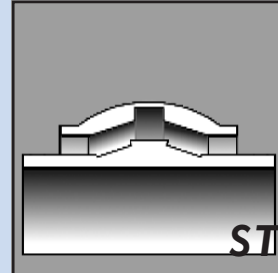

Wide Inner Race



Split Housing



Diamond Faceted Set Screw

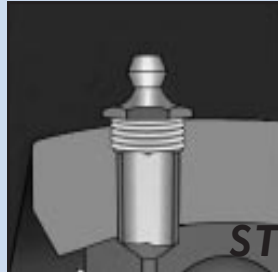

Pin & Dimple



Felt Seals



Double Locking Set Screw

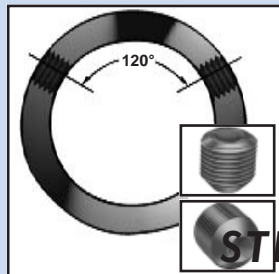

120° Set Screw Positioning



Skwezloc Locking

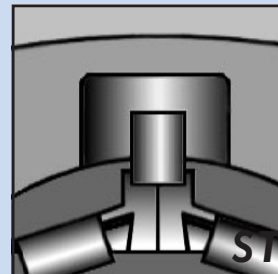

Lock Pin

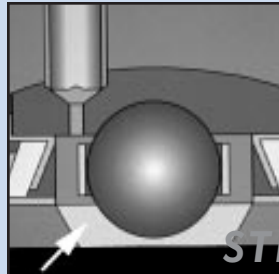

Inner Ring Zone Hardening



Felt Seal

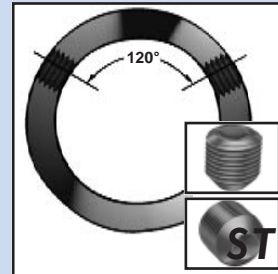

120° Set Screw Locking

Note: MTO (Made To Order), STD (Standard)

See Pages 34-35 For Rubber Mounted Air Handling Bearings.

# SEALMASTER® APPLICATIONS...

## CONSTRUCTION...

Construction equipment varies widely from hot asphalt pavers to earth movers to large material handlers, etc... The timing of construction projects is critical and it is important that equipment lasts through an entire season. Unexpected downtime delays are unacceptable.

Construction machinery typically is used outdoors and requires protection from weather, dirt, road debris, wide temperature fluctuations, etc... Bearings are normally subjected to heavy loads with vibration and operate at slow to high speeds. Seals may be exposed to abrasive materials and sharp objects found in construction environments which can lead to instant bearing problems.

In particular: Paver bearings support augers that come into direct contact with hot grading asphalt that quickly wears seals and races away. In this application bearings operate at slow to moderate speeds.

Another example: Construction saws need to cut both dry and wet concrete are also subjected to vibration and abrasive contaminant from the concrete dust. Mounted Bearings support the arbor shafts and are unusually ceiling mounted.

**Key Concerns...** include seal damage, shock loading, vibration, abrasives, loss of shaft lock, high temperatures, high speeds, and liquid and dry contamination.

Sealmaster bearings are frequently specified for:

- Concrete Saws.
- Street Sweepers.
- Front End Loaders.
- Wheel Compactors.
- Excavators.
- Paving Equipment.
- Spreaders.
- Backhoes.
- Cranes.
- Power Shovels.



## GOLD LINE SOLUTIONS FOR CONSTRUCTION APPLICATIONS.

### Vibration/Shock and Impact Loading:

#### **Housing Fits...**

Tight housing fit (interference) between the bearing insert and housing may be required to prevent the outer race from rotating in the housing. This minimizes fretting on the outer race and housing bore. Available as made to order on ball and roller bearings.

#### **Locking Pin...**

The locking pin design significantly lessens the likelihood of outer ring rotation that could compromise the integrity of the lubrication system.

#### **Misalignment...**

The Sealmaster misalignment capabilities  $\pm 2^\circ$  on ball and  $\pm 3^\circ$  on roller bearings overcome static alignment problems during installation which can be caused by inaccuracies in framework design.

#### **Housing Style...**

Piloted Flange housings are often recommended for these applications due to the 360° mounting shoulder for positive installation in the machine structure. This added support greatly reduces bolt stresses. Six mounting holes are standard on 4 7/16" through 5" roller bearing bore sizes. Sealmaster also recommends the use of 4 bolt hole mounting configurations on the pillow block style housing.

Throughout the Sealmaster ball bearing line solid base housings are standard and contribute to a more rigid mounting system.

#### **Locking Mechanism...**

Double sided set screw shaft locking, available standard on roller and medium duty ball bearings, uses four set screws to hold the bearing to the shaft and is recommended for these applications.

### Contamination:

#### **Seals...**

Sealmaster's field proven felt lined labyrinth seals keep contaminants out and lubrication in. The felt filtering material is a highly effective barrier against abrasive particulate and the labyrinth construction allows for the grease and contamination to purge during re-lubrication. Depending upon individual application needs, other optional sealing arrangements can be considered and are found in the engineering section starting on page 176.

Sealmaster has developed a specialized MTO product known as "Shielded Ball". See picture on facing page. This extraordinary bearing incorporates a heavy duty multiple barrier sealing system that has proven valuable in the aggregate environment. One impressive feature is the use of thick structural shields staked onto the inner race to repel large aggregates. These shields protect the multiple barrier sealing system which consists of a dense high durometer seal wedge, a wave spring seal feature, and a third metal flinger contact seal. Between these features are grease chambers. Contact Sealmaster application engineering for more information on this most unique MTO product.

#### **End Caps...**

There are a variety of made to order end caps that can be manufactured for specific needs. End caps can be produced from stainless or low carbon steels, with or without coatings, to suit application needs. See *Beverage Bearing and HF/HFT Furnace bearing product lines for End Cap solution examples.*

**Elevated Temperatures...** Refer to the High Temperature application section on pages 130-131.

# STANDARD & CUSTOM SOLUTIONS FOR CONSTRUCTION APPLICATIONS

GOOD AS GOLD...  
NO EQUAL!

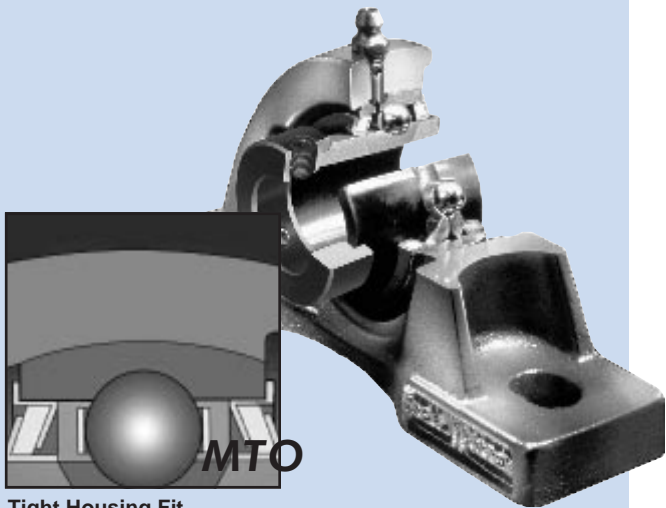

Tight Housing Fit

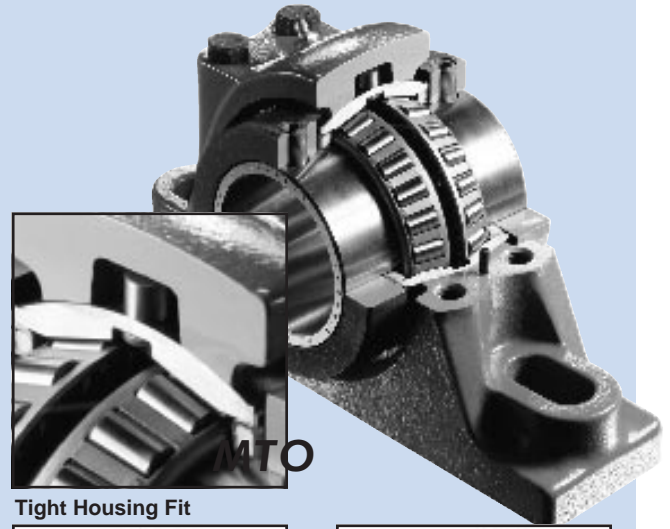

Tight Housing Fit



Piloted Flange Housing



4 Bolt Pillow Block

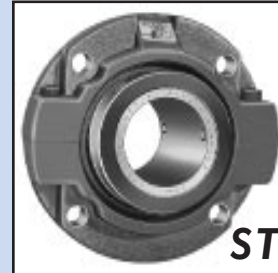

Piloted Flange Housing



4 Bolt Pillow Blocks

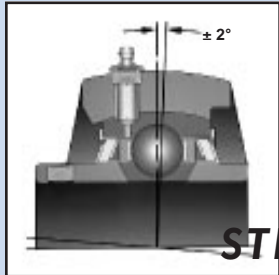

± 2° Misalignment



Solid Base Housings

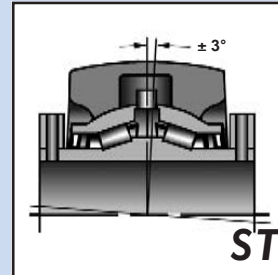

± 3° Misalignment



Locking Pin & Dimple



Double Lock Insert

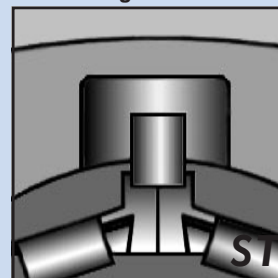

Locking Pin



Felt Seals

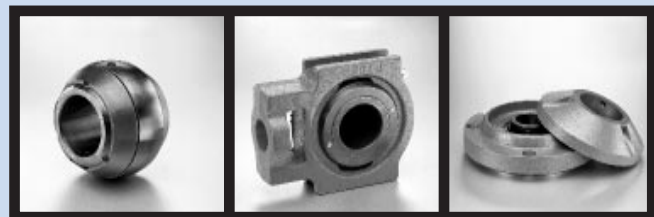

MTO

Examples of "Shielded Ball" Ball Bearings

Note: MTO (Made To Order), STD (Standard)

# SEALMASTER® APPLICATIONS...

## WET ENVIRONMENTS...

Many harsh applications expose bearings to water and chemicals which can contaminate bearing rolling elements and housings thereby reducing bearing life. Increased uptime is an overriding need in these applications and can be accomplished by preventing this rapid corrosion.

For example, machinery that packages food and beverages must remain extremely clean and is frequently washed down with high pressure caustic cleaning solutions. This can initiate corrosion, contaminate the bearing, and wash out valuable grease.

Another application where water creates a problem for mounted bearings is waste water treatment. Orbals and belt presses are subjected to moisture, chemicals, and sewage contamination. Keeping bearings operational and free from internal corrosion is critical to optimizing bearing life.

**Key Concerns...** include slurry, moisture, pressure wash, and chemicals.

Sealmaster bearings are frequently specified for:

- Truck and Water Washers.
- Food Processing.
- Beverage Filling.
- Pulp and Paper.
- Waste Water Treatment.
- Vertical Stroke Shake-Outs.
- Fluidizing Beds.
- Foundry Shake-Out Conveyors.
- Deburring Machines.
- Marine Applications.

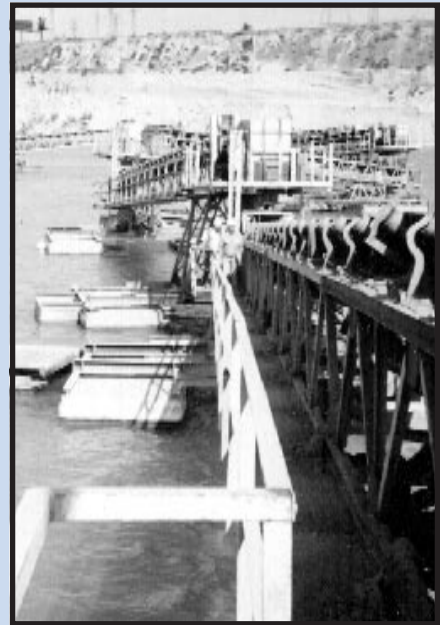

## GOLD LINE SOLUTIONS FOR WET ENVIRONMENTS APPLICATIONS.

### Contamination and Corrosion:

#### Seals...

The Sealmaster standard contact seal has good chemical resistance properties and lubrication retention characteristics in operating conditions up to 250°F.

Sealmaster Gold Line Ball Bearings can be customized with a variety of contact seal options. Auxiliary flingers are also available when needed. The most frequently used wet condition MTO seals on ball bearings are the UltraGard Seal (spring loaded buna oil seals) and the ProGard Seals (double lip contact). Refer to the seal section found on page 188 in the engineering section.

#### End Caps...

There are a variety of end caps that can be manufactured for specific application needs. End caps can be produced from stainless or low carbon steels, with or without coatings, and in open or closed configuration. *See our Beverage Bearing product line on page 86.*

#### Auxiliary Shield...

On some housing configurations, supplementary shields and gaskets can be included to protect the back side seals from corrosive materials and high pressure sprays that may be in the surrounding climate.

#### Lubrication...

Lubrication frequency may need to be increased to ensure adequate lubrication is maintained. Optional food grade greases are available where required. Sealmaster has had good experience with special wash out preventative lubricants. Contact application engineering for further information.

#### Coatings...

Sealmaster CR Duty mounted ball and roller bearings can be manufactured with a unique fluoropolymer coated cast iron corrosion-resistant housings. This offers excellent resistance to:

- Moisture.
- Abrasion.
- Peeling.
- Sticky Contaminants.
- High Pressure Washes.
- Most Chemical Solvents up to PH Levels of eleven.

**See page 88 for a detailed description of CR Ball Bearings, and page 122 for CR Roller Bearings.**

Thin dense chrome (TDC) coated races are available on request. This coating resists corrosion 10 to 15 times longer than ordinary bearing materials. TDC totally covers the entire surface area of the inner and outer race and is between 10-15% harder than industry standard bearing raceways.

#### Materials...

The following corrosive retardant components can be assembled into your bearings:

- Coated Set Screws
- TDC Raceways
- Brass and Nylon Coated Retainers
- Stainless Steel...Balls, Washers, End Caps, Seals, Lubrication Fittings, Flingers.

# STANDARD & CUSTOM SOLUTIONS FOR WET ENVIRONMENTS APPLICATIONS

**GOOD AS GOLD...  
NO EQUAL!**

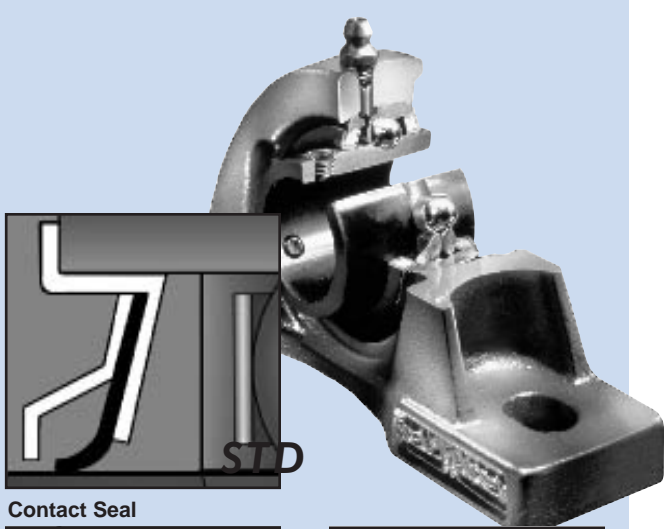

Contact Seal

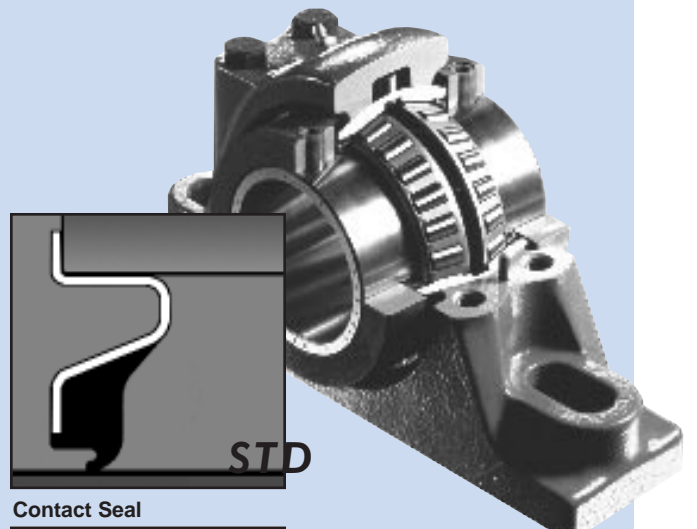

Contact Seal



Ultra Gard Seal



Fluoropolymer Cast Iron Coating



Fluoropolymer Cast Iron Coating



ProGard Seal



TDC Inner Ring

**See Our Standard  
CR Duty Ball Bearings**  
Corrosion-Resistant Product  
Line on pages 88-89



End Caps

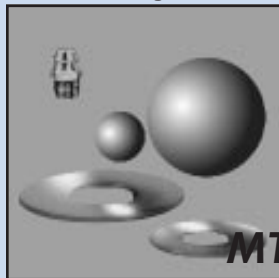

Stainless Steel Components

**Also See Our Standard  
CR Duty Roller Bearings**  
Corrosion-Resistant Product  
Line on pages 122-123



Auxiliary Shield

**And See Our Standard  
Beverage Bearing**  
Product Line on pages 86-87

Note: **MTO** (Made To Order), **STD** (Standard)



# SEALMASTER® APPLICATIONS...

## AGGREGATE/MINING...

Aggregate and Mining applications vary widely in the types of equipment used and in the types of material being conveyed. Aggregate conveyors move stone and rock between primary, secondary, and tertiary crushers and transport finished product into trucks for highway construction projects, and industrial, commercial and residential building needs.

Bearings are subjected to heavy loads with vibration and are exposed to rock dust and grit that tend to build-up on the seals. Generally, the speeds are slow to moderate. Conveyors are often sprayed with water to keep the dust down, thus creating a slurry. Often, bearing components are buried in the sand making sealing more difficult.

**Key Concerns...** include shock loads, loss of shaft lock, abrasive media, and water and dust contamination.

Sealmaster bearings are frequently specified for:

- Conveyor Pulleys.
- Augers.
- Screens.
- Crushers...Cone, Roll, Impact, Jaw, Gyrotary.
- Conveyor Take-Ups.
- Screw Conveyors.
- Stackers.
- Feeders... Vibrating, Stepdeck, Recipricating, Wobblers.



## GOLD LINE SOLUTIONS FOR AGGREGATE/MINING APPLICATIONS.

### Contamination:

#### **Seals...**

Sealmaster's field proven felt lined labyrinth seals keep contaminants out and lubrication in. The felt filtering material is a highly effective barrier against abrasive particulate and the labyrinth construction allows for grease and contamination to purge during re-lubrication. Rock plants generate an appreciable amount of stone dust. Water washdown is commonly used to calm the dust. Contact seals are recommended for these applications. Depending upon your individual application needs, you may consider the other optional sealing arrangements found on page 188 in our engineering section.

Sealmaster has developed a specialized MTO Ball Bearing known as "Shielded Ball". See picture on facing page. This extraordinary bearing incorporates a heavy duty multiple barrier sealing system that has proven valuable in the aggregate environment. One impressive feature is the use of thick structural shields staked onto the inner race to repel large aggregates. These shields protect the multiple barrier sealing system which consists of a dense high durometer seal wedge, a wave spring seal feature, and yet a third metal flinger contact seal. In between these features are grease chambers. Contact Sealmaster application engineering for more information.

#### **Wide Inner and Outer Race...**

This feature distributes the dynamic misalignment forces over a larger surface area between the bearing insert/cartridge and housing. This also provides a greater internal chamber volume that allows for increased grease capacity.

### Shock and Impact Loading:

#### **Housing Fit...**

Tight housing fit (interference) may be required between the bearing insert and the housing to prevent the outer race from rotating in the housing. This minimizes fretting on the outer race and housing bore. Available as made to order on ball and roller design.

#### **Locking Pin...**

The locking pin design significantly lessens the likelihood of outer ring rotation that could compromise the integrity of the lubrication system.

#### **Misalignment...**

The Sealmaster misalignment capabilities,  $\pm 2^\circ$  on ball and  $\pm 3^\circ$  on roller bearings overcome static alignment problems caused by inaccuracy in framework design and settling of the equipment on uneven ground.

#### **Internal Clearances...**

Reduced internal clearance can be applied to ball bearings on a made to order basis to reduce pounding forces and internal stresses created from vibration and impact loads.

If required, Tapered Roller Bearings can be modified with reduced clearance ("endplay") which minimizes edge loading. This distributes forces more uniformly across each loaded roller. Contact application engineering for application review.

#### **Locking Mechanism...**

Double sided set screw shaft locking, available standard on roller and medium duty ball bearings, uses four set screws to hold the bearing to the shaft and is recommended for these applications.

Contact application engineering with your application parameters for exact bearing selection (630-898-9620).

# STANDARD & CUSTOM SOLUTIONS FOR AGGREGATE/MINING APPLICATIONS

GOOD AS GOLD...  
NO EQUAL!

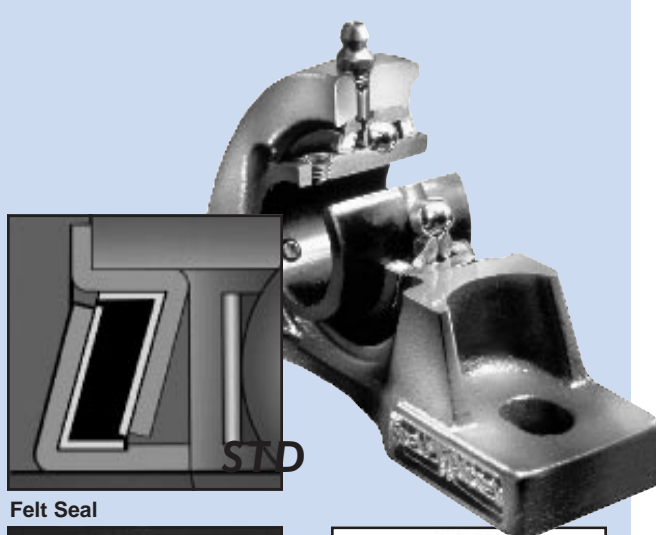

Felt Seal

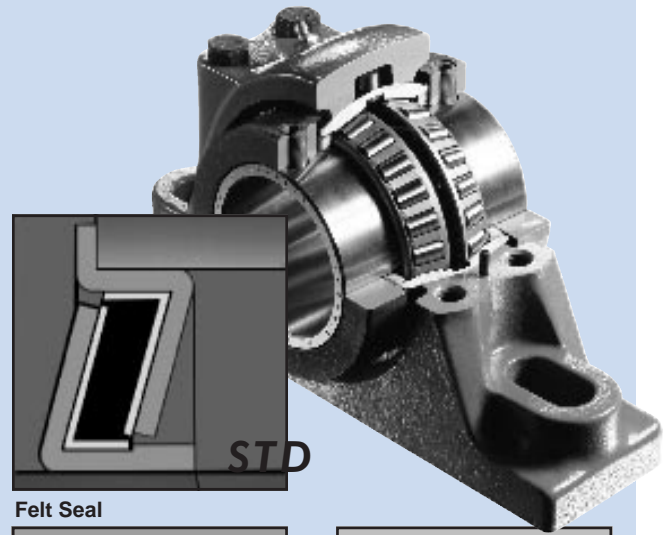

Felt Seal

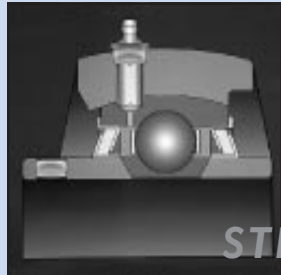

Wide Inner & Outer Ring



Double Side Set Screw Locking

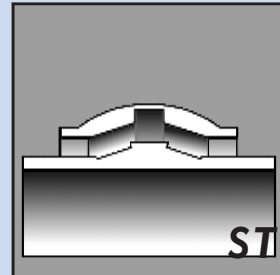

Wide Inner & Outer Ring

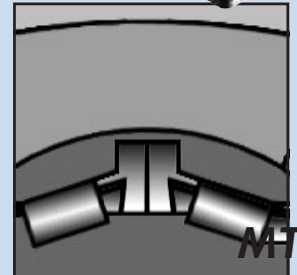

Reduced Internal Clearance

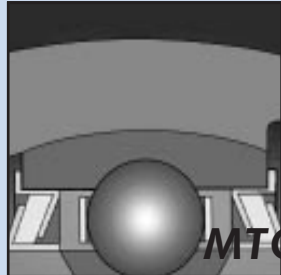

Tight Housing Fit

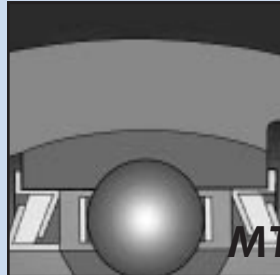

Reduced Internal Clearance

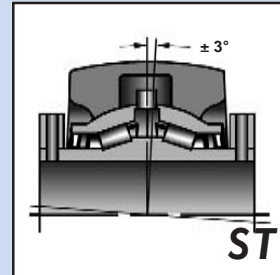

3° Misalignment

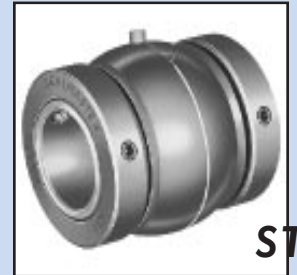

Double Side Set Screw Locking



Locking Pin & Dimple

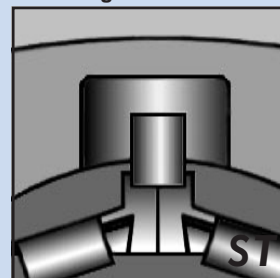

Locking Pin

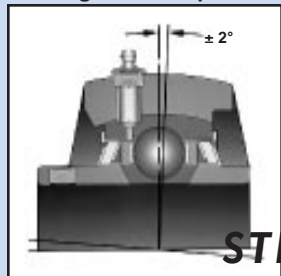

$\pm 2^\circ$  Misalignment



Examples of "Shielded Ball" Ball Bearings

Note: MTO (Made To Order), STD (Standard)

# SEALMASTER® APPLICATIONS...

## ECENTRIC DRIVES...

This equipment transfers or separates product through a reciprocating motion produced by an eccentric drive. Eccentric drive systems utilize a weight displaced asymmetrically from the centerline of rotation which creates a constantly changing force. Constant vibration and shock loads can pound the bearing rolling elements and races to reduce operational life by brinelling raceways and accelerating metal fatigue.

Eccentric drive applications tend to operate under high vibration and impact loading. The dynamic forces can cause high stress in bearing components. Many of these applications also operate in highly contaminated environments such as sand, dust, chips, etc.

**Key Concerns...** include shock and impact loading, vibration, loss of shaft lock, contamination, misalignment.

Sealmaster bearings are frequently specified for:

- Gyration Screens.
- Vertical Stroke Shake-Outs.
- Vibrating Conveyors.
- Fluidizing Beds.
- Agitators.
- Foundry Shake-Out Conveyors.
- Sand Reclamation.
- Deburring Machines.

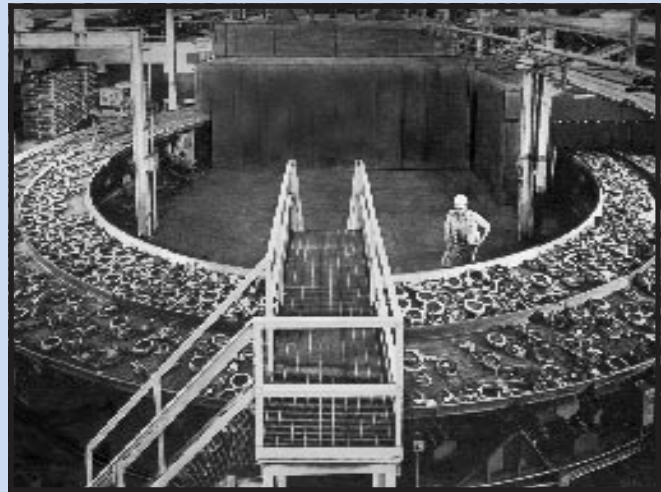

Quality-made SEALMASTER bearings help vibrate 60-tons of conveyor and hot castings in this **tough** installation. This 45-ton dynamically-balanced conveyor, vibrating at 360 cycles/minute, handles and cools 15 tons of hot foundry castings on a continuous basis. It operates on custom-modified SEALMASTER ball and roller bearings which have special tight housing fit-ups for this demanding vibratory service.

## GOLD LINE SOLUTIONS FOR ECCENTRIC DRIVES APPLICATIONS.

### Vibration/Shock and Impact Loading:

#### **Housing Fit...**

Tight housing fit (interference) is required between the bearing insert and housing to prevent the outer race from rotating in the housing. This minimizes fretting on the outer race OD and Housing bore. Available as made to order on ball and roller design.

#### **Misalignment...**

The Sealmaster misalignment capabilities,  $\pm 2^\circ$  on ball and  $\pm 3^\circ$  on roller bearings overcome static alignment problems during installation which can be caused by inaccuracy in framework design.

#### **Internal Clearances...**

Reduced internal clearance can be applied to ball bearings on a made to order basis to reduce pounding forces and internal stresses created from vibration and impact loads.

If required, Tapered Roller Bearings can be modified with reduced clearance ("endplay") which minimizes edge loading. This distributes forces more uniformly across each loaded roller. Contact application engineering for application review.

#### **Housing Styles...**

Piloted Flange housings are often recommended for these applications due to the 360° mounting shoulder for precision installation in the machine structure. This added support greatly reduces bolt stresses. Six mounting holes are standard on 4 7/16" through 5" roller bearing bore sizes. Sealmaster also recommends the use of four bolt hole mounting configurations on the pillow block style housings. Throughout the Sealmaster ball bearing line, solid base housings are standard and contribute to a more rigid mounting system.

#### **Locking Mechanism...**

Double sided set screw shaft locking, available standard on roller and medium duty ball bearings, uses four set screws to hold the bearing to the shaft and is recommended for these applications.

### Contamination:

#### **Seals...**

Sealmaster's field proven felt lined labyrinth seals keep contaminants out and lubrication in. The felt filtering material is highly effective barrier against abrasive particulate and the labyrinth construction allows for the grease and contamination purge during re-lubrication. Depending upon your individual application needs, you may consider the other optional sealing arrangements found on page 188 in our engineering section.

### Commonly Used Sealmaster Bearings:

Generally, Roller bearings are specified with a "TF" suffix and will be modified with a Tight Fit between the housing and the bearing insert. All Tight Fit bearings are furnished with the cap bolts snugged by hand and tagged with proper torque specifications. For reduced internal clearances ("RC suffix) contact Sealmaster Engineering for application review.

To order a Tight Fit bearing, add "TF" to the catalog part number.

For example: "RPB215-2TF"

SEALMASTER ENGINEERING SHOULD BE CONTACTED TO REVIEW ANY SPECIFIC APPLICATION REQUIREMENTS.

# STANDARD & CUSTOM SOLUTIONS FOR ECCENTRIC DRIVES APPLICATIONS

GOOD AS GOLD...  
NO EQUAL!

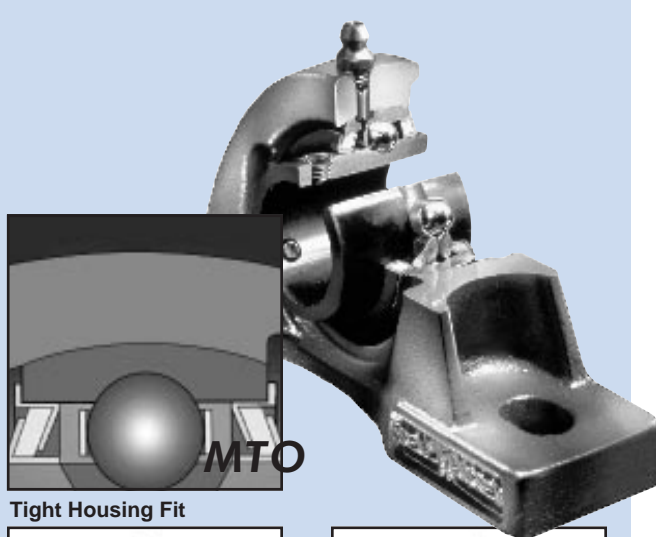

Tight Housing Fit



**STD**



**STD**

Piloted Flange Housing Styles

Four Bolt Pillow Blocks

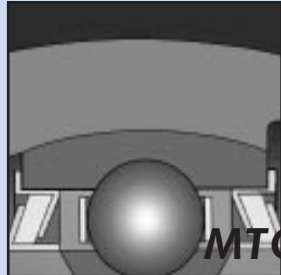

Tight Internal Clearances



Solid Base Housing Styles



Double Side Set Screw Locking

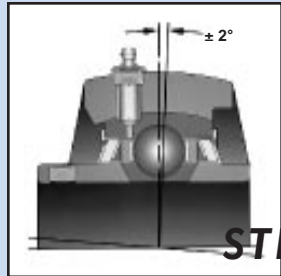

$\pm 2^\circ$  Misalignment

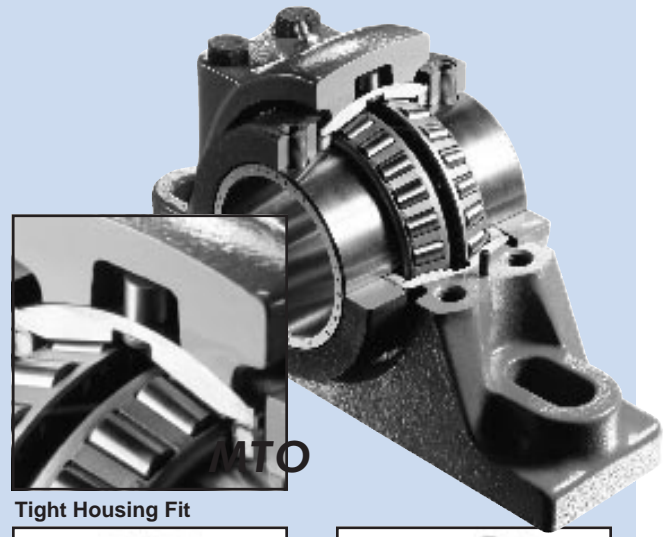

Tight Housing Fit



**STD**



**STD**

Piloted Flange Housing Styles

Four Bolt Pillow Block

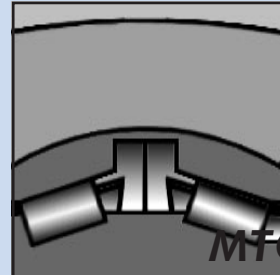

Tight Internal Clearances

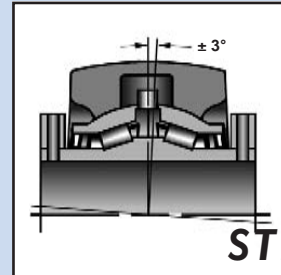

$\pm 3^\circ$  Misalignment



Double Side Set Screw Locking

# SEALMASTER® APPLICATIONS...

## MIXERS...

Industrial mixers are designed to combine materials in industries such as paint, ink, film, chemicals and food products. Mixers benefit from the standard Gold platform as well as special bearing modifications that address the demanding application dynamics.

Thrust loads are present due to the shaft weight, the mixing wheel, and the media being mixed. Often, mixers have a vertical shaft orientation. The bearings typically have close center distances and an extended shaft cantilevered into a mixing drum. The blade is positioned at the end of the mixing shaft to blend media. Shaft deflection results in dynamic loading on the bearing which causes dynamic misalignment. Often bearings must be protected from liquid splash or dry media debris.

**Key Concerns...** include misalignment, thrust, system imbalance, loss of shaft lock, and liquid, dry, and chemical contamination.



## GOLD LINE SOLUTIONS FOR MIXERS APPLICATIONS.

### Misalignment:

The Sealmaster misalignment capabilities,  $\pm 2^\circ$  on ball and  $\pm 3^\circ$  on roller bearings overcome static alignment problem associated with the extended cantilever set up found in mixers.

### Thrust Loading:

#### ***Bearing Load Capability...***

Sealmaster RPB tapered roller bearings are the recommended bearing choice for mixers because of their increased ability to perform heavy combined radial and thrust loading. Although, high speed applications may require the use of mounted ball bearings.

#### ***Locking Mechanism...***

Double sided set screw shaft locking, available standard on roller and medium duty ball bearings, uses four set screws to hold the bearing to the shaft and is recommended for these applications.

### System Imbalance:

#### ***Wide Inner and Outer Race...***

This feature distributes the dynamic misalignment forces over a large surface area between the bearing insert/cartridge and housing. This also provides a greater internal chamber volume that allows for increased grease capacity.

#### ***Locking Pin...***

The locking pin design significantly lessens the likelihood of outer ring rotation that could compromise the integrity of the lubrication system.

#### ***Housing Fits...***

Sealmaster provides increased useful bearing life by incorporating a custom fit between the bearing insert/cartridge and the housing to minimize corrosive fretting, and accommodate dynamic misalignment.

#### ***Internal Clearances...***

In Sealmaster RPB Roller Bearings the optional, reduced clearance modification diminishes edge loading from dynamic shaft misalignment caused by bending of the shaft and the overhung load due to viscous or heavy media.

### Contamination:

#### ***Seals...***

In wet or slurry applications the Sealmaster contact seal with protective flingers is suggested. Seal materials may need to be considered if media being mixed contains any aggressive chemicals.

Non-purgable spring loaded "V" seals (oil seals) can be utilized for grease retention on ball bearings in these vertical applications.

#### ***Lubrication...***

Lubrication frequency may need to be increased to ensure adequate lubrication is maintained. Optional food grade greases are available where required.

**Contact application engineering with your application parameters for exact bearing selection (630-898-9620).**

# STANDARD & CUSTOM SOLUTIONS FOR MIXERS APPLICATIONS

GOOD AS GOLD...  
NO EQUAL!

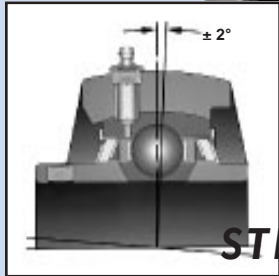
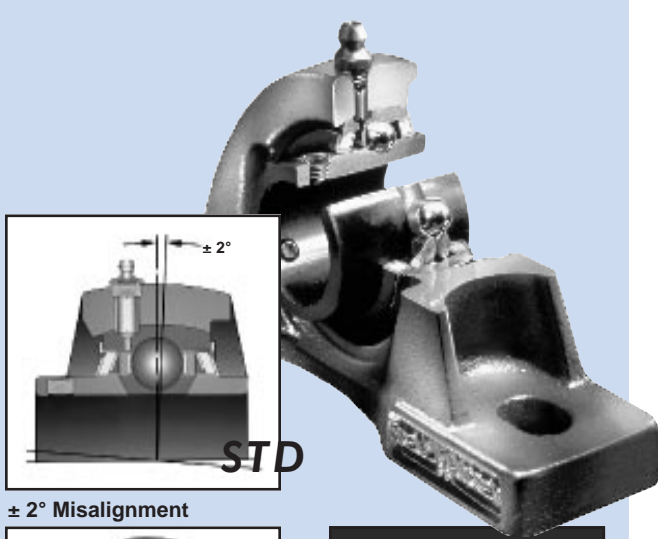

STD

± 2° Misalignment



STD

Double Sided Set Screw Locking

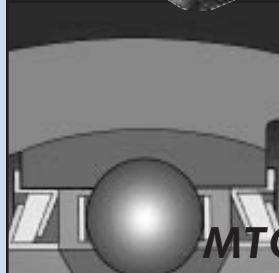

MTO

Reduced Internal Clearance

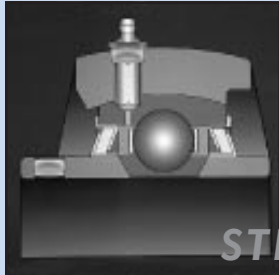

STD

Wide Inner & Outer Race



MTO

Spring Loaded "V" Seal

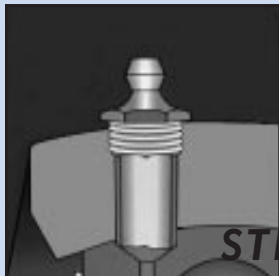

STD

Locking Pin & Dimple

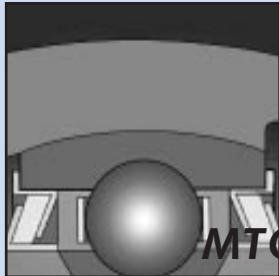

MTO

Tight Housing Fit

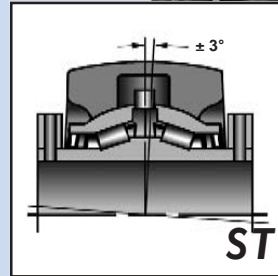
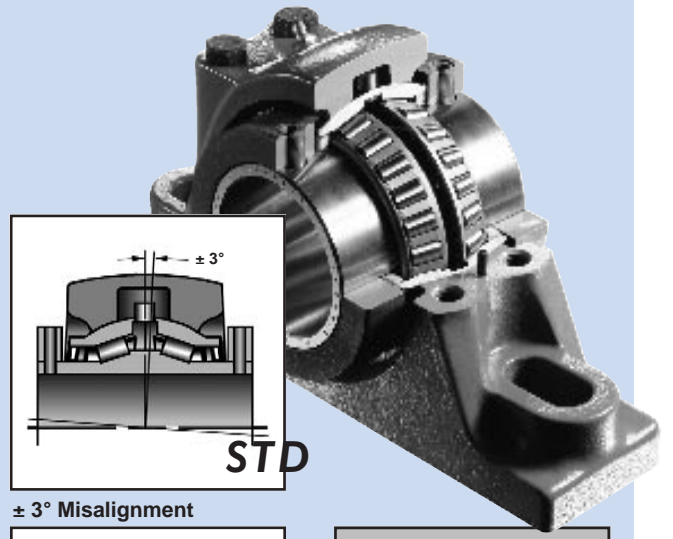

STD

± 3° Misalignment



STD

Double Sided Set Screw Locking

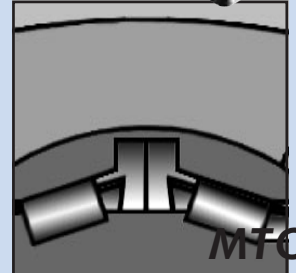

MTO

Reduced Internal Clearance

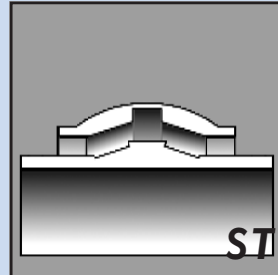

STD

RCI Inner & Outer Race



STD

Contact Seal

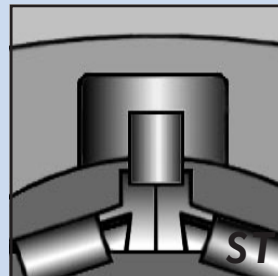

STD

Locking Pin



MTO

Tight Housing Fit

Note: MTO (Made To Order), STD (Standard)

# SEALMASTER®

## ROD ENDS AND SPHERICAL BEARINGS

SEALMASTER Bearings entered the rod end and spherical plain bearing market in 1956 providing customers a broad product line offering for over 40 years. The product was manufactured in our plant in Aurora, Illinois until 1978. From 1978 through 1995, these products were manufactured exclusively for Emerson by a qualified vendor. To offer more value to our customers we now are manufacturing this product in our Valparaiso, Indiana plant. We are pleased and proud to offer you this new line of SEALMASTER rod ends and spherical plain bearings.....

### With These Performance Advantages!

- Improved Rod End Design
- Finite Element Analysis Used For Development
- Close and Consistent Ball-Race Fit
- Re-engineered Self-lubricating TEFLON\* and DELRIN\* Rod Ends

Combining years of innovative bearing design experience with a unique manufacturing process, our engineers have developed three piece rod ends with steel and bronze races for enhanced performance.

SEALMASTER Bearings has built a solid reputation for the highest quality, most reliable products as well as an outstanding ability to understand and meet the needs of customers. Our in-house design, manufacturing and total technological capabilities are made possible by experienced product engineers and production specialists who are devoted to a single goal – producing the highest quality, most dependable rod ends and spherical bearings possible... worthy of carrying the SEALMASTER brand name.

SEALMASTER rod ends and spherical bearings are available in a wide variety of designs, bore diameters, thread sizes and materials to meet most industrial application requirements.

As part of our continuing commitment to quality – Statistical Process Control and state-of-the-art equipment is integral to the total manufacturing process to assure the highest quality possible. Our development and testing programs give us constant improvements in design, processes and quality to enable us to better serve your rod end and spherical plain bearing requirements.



The next time you specify a rod end or spherical plain bearing...a bearing that must meet the demands of discerning designers, engineers and maintenance personnel...  
**Specify SEALMASTER bearings!**



\*TEFLON and DELRIN are registered trademarks of the DuPont Company

# TABLE OF CONTENTS



	Page Number
<b>Introduction</b> .....	144-146
<b>Selection Guide</b> .....	147
<b>Application</b> .....	148-149
<b>Lubrication</b> .....	149
<b>Bearing Nomenclature</b> .....	150
<b>Extra Capacity Precision Series - Rod Ends</b> .....	151-153
AR <i>Three-Piece Female</i> Steel-on-Steel .....	151
ARE <i>Three-Piece Male</i> Steel-on-Steel .....	152
ARE-20 <i>Three-Piece Male</i> Steel-on-Steel .....	153
<b>Precision Series - Rod Ends</b> .....	154-155
TR <i>Three-Piece Female</i> Steel-on-Steel .....	154
TRE <i>Three-Piece Male</i> Steel-on-Steel .....	155
<b>Precision Series - Rod Ends</b> .....	156-157
CFF-T <i>Two-Piece Female</i> Self-Lubricating TEFLON Lined .....	156
CFM-T <i>Two-Piece Male</i> Self-Lubricating TEFLON Lined .....	157
<b>Commercial Series - Rod Ends</b> .....	158-163
TF <i>Three-Piece Female</i> Bronze-on-Steel .....	158
TM <i>Three-Piece Male</i> Bronze-on-Steel .....	159
CFF <i>Two-Piece Female</i> Steel-on-Steel .....	160
CFM <i>Two-Piece Male</i> Steel-on-Steel .....	161
CTFD <i>Three-Piece Female</i> Self-Lubricating DELRIN .....	162
CTMD <i>Three-Piece Male</i> Self-Lubricating DELRIN .....	163
<b>Y - Studs</b> .....	164
<b>Misalignment - Rod Ends and Spherical Bearings</b> .....	165
<b>Precision Series - Spherical Bearings</b> .....	166-167
SBG/SBG-S/SBG-SA/SBG-SS -Metal-to-Metal .....	166
COR Stainless Steel-on-Stainless Steel .....	167
<b>Commercial Series - Spherical Bearings</b> .....	168
COM Steel-on-Steel-Commercial .....	168
<b>Precision Series Spherical Bearings-Special Purpose</b> .....	169
FLBG Bronze-on-Steel .....	169
<b>Precision Series - Heavy Duty Spherical Bearings</b> .....	170-171
BTS-LS Steel-on-Steel Bellows Type Sealed .....	170
BH-LS Steel-on-Steel Heavy Duty .....	171
<b>Engineering/General Information</b> .....	172-173
Recommended Housing Bore Diameters .....	172
Design Modifications .....	173
Application Inquiry Worksheet .....	174-175



## Three-Piece Rod Ends

SEALMASTER three-piece rod ends incorporate a one-piece race formed around a hardened steel chrome plated ball in a controlled manufacturing process. Three-piece construction offers flexibility for alternative race materials designed to help solve specific application problems. Consult our engineering department for material combinations available to meet your application needs.

### Machined Steel Housing

- Increased wrench flat depth on female rod ends to facilitate assembly and installation.

### One-Piece Race

- Improved spherical ball–race conformity for even load distribution.

### Ball

- Alloy steel, heat treated, chrome plated for wear resistance properties.



## Two-Piece Rod Ends

SEALMASTER two-piece design rod ends consist of a machined housing formed around a hardened steel chrome plated ball. This construction offers more load capacity than three-piece design with like housing materials because of greater housing cross section.

### Machined Steel Housing

- Increased wrench flat depth on female rod ends to facilitate assembly and installation.

### Ball

- Alloy steel, heat treated, chrome plated for wear resistance properties.



## Two Types of Self-Lubricating Rod End Designs Are Offered.



**Two-Piece TEFLON Rod Ends** combine the strength of two-piece design and self-lubricating TEFLON liner for use in a wide variety of industrial applications.

**DELRIN Rod Ends...** for light duty applications where relubrication should be avoided.

# TYPE, SIZES, AVAILABILITY, SELECTION FACTORS

## Selection Guide

The tables below are intended as a guide to help choose the rod end or spherical plain bearing best suited for the application. Careful consideration should be given when selecting rod ends and spherical bearings. For special rod end or spherical bearing requirements – See Application Data Worksheet on pages 174-175. We recommend the product be tested to be sure it meets minimum application requirements. Contact our engineering department for application assistance.

### Other important factors that should be considered are:

- Duty cycle
- Speed (surface velocity in FPM)
- Oscillating angle
- Installation requirements, retention methods, housing and shaft fits
- Allowable wear
- Environmental conditions

### Rod Ends

Series	Pages	Bore Size	Max Static Load Capacity (lbs)	Construction	Race Material	Static Load	Reversing Load	Shock Load	Maximum Temp.	Grease Fitting Available	Y-Stud	Self-Lubricating	Relative Price Index <sup>s</sup>
AR/ARE/ARE-20	151-153	3/16-3/4"	2,850 – 23,200	3 Pc.	Steel	***	***	***	350 F	Y	N/A	N	2.0
TR/TRE	154-155	3/16-1"	900 – 21,000	3 Pc.	Steel	**	***	***	350 F	Y	Y	N	1.0
CFF-T/CFM-T	156-157	3/16-1"	865 – 21,000	2 Pc.	TEFLON Liner	**	**	**	250 F	N/A	Y	Y	1.7
TF/TM	158-159	3/16-3/4"	900 – 11,300	3 Pc.	Bronze	**	**	**	350 F	Y	Y	N	0.8
CFF/CFM	160-161	3/16-1"	950 – 25,200	2 Pc.	Steel	**	**	**	350 F	Y	Y	N	0.7
CTFD/CTMD	162-163	3/16-3/4"	800 – 6,600	3 Pc.	DELTRIN	*	*	*	150 F	N/A	Y	Y	0.8

### Spherical Bearings

Series	Page	Bore Size	Max Static Load Capacity (lbs)	Construction	Race Material	Static Load	Reversing Load	Shock Load	Maximum Temp.	Relative Price Index
SBG	166	3/16-1"	2,750 – 52,000	2 Pc.	Bronze	**	**	**	350 F	1.0
SBG-S	166	3/16-1"	6,480 – 125,000	2 Pc.	H.T. Steel	***	***	***	350 F	0.8
SBG-SA	166	1/2-1"	26,900 – 125,000	2 Pc.	H.T. Steel	***	***	***	350 F	0.9
SBG-SS	166	3/16-1"	4,400 – 83,000	2 Pc.	Stainless Steel	**	**	**	500 F	1.0
COR	167	3/16-1"	4,800 – 93,500	2 Pc.	Stainless Steel, Heat Treated	***	***	***	500 F	1.4
COM	168	3/16-1"	3,250 – 54,700	2 Pc.	Steel	**	**	**	350 F	0.5
FLBG	169	3/16-1"	2,960 – 48,200	3 Pc.	Bronze	**	**	**	350 F	1.5
BTS-LS	170	3/4-1 1/2"	31,500 – 130,000	2 Pc.	Steel	***	***	***	350 F	2.3
BH-LS	171	1-2"	69,500 – 221,000	2 Pc.	Steel	***	***	***	350 F	1.6

\*Good      \*\*Better      \*\*\*Best

<sup>s</sup> -For Estimating Purposes Only — Individual Sizes Will Vary; Subject to Change Without Notification

## Application

SEALMASTER rod ends and spherical plain bearings are designed to provide an efficient smooth transfer of motion in a wide variety of applications and equipment. This motion is usually associated with various types of linkage controls. Commonly referred to as plain or sliding bearings, they are designed primarily to assist and provide motion transfer, support a load, allow for angular motion and angular misalignment.

SEALMASTER rod ends and spherical bearings serve the industrial market. Typical applications for rod ends and spherical plain bearings can be found in:

- Textile Equipment
- Packaging Machinery
- Food Processing
- Labeling Machinery
- Bakery Equipment
- Industrial Fans
- Recreational Equipment
- Construction Equipment
- Farm/Garden Machinery
- Exercise Machines
- Bottling Equipment
- Dairy Machinery
- Printing Machinery
- Agricultural Equipment
- Material Handling
- Transportation Equipment
- Mining Machinery
- Off-Road Equipment

SEALMASTER rod ends can be joined together or connected with a threaded rod or tube to form linkage assemblies allowing design engineers flexibility in transferring motion between points with long center distances.

Normal operation of rod ends results in wear of the raceways or fatigue or fracture of the outer member. Give consideration to this in the design of the equipment.

Spherical plain bearings provide a similar function as rod ends and must be supported in a housing. Spherical bearings afford customers greater load rating per equivalent rod end bore size. This occurs because rod end load capacity is controlled by the head and shank geometry. Spherical bearings have a larger bearing area and generally are less restricted by the housing material or dimensions in which they are mounted.

## Load Ratings

### Rod Ends

*Static radial load ratings* are applied perpendicular to the bearing ball bore and are a function of strength of race and housing materials. SEALMASTER static load ratings listed in this catalog are maximum working loads and factors of safety should be applied as necessary. External conditions including mounting components, bolts, pins and housings should be considered separately when designing this product into an application.

*Static axial load ratings* are applied parallel or through the bearing ball bore. In general, rod ends are not intended to carry axial loads. Applications of rod ends with axial loading should be reviewed with engineering.

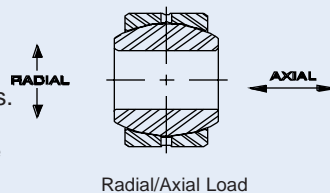

### Spherical Bearings

*Static radial load ratings* listed in the catalog are based on a maximum permanent set in the bearing race of .2% of normal ball diameter.

*Static axial load ratings* are approximately 20% of the radial static load ratings listed with each unit. Caution should be exercised in designing adequate housings to support spherical bearings.

### Angular Misalignment

SEALMASTER rod ends and spherical bearings are primarily selected for their ability to withstand misalignment. As an example, a rod end and a shaft may not always be positioned at right angles and misalignment capability is important. Misalignment can occur through wear, tolerance build-up, structural deflection, or in design. For more information on misalignment, refer to page 165 in this catalog.

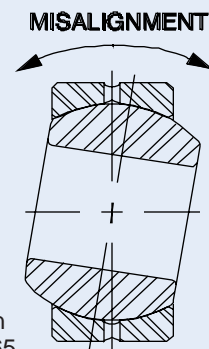

### Common Retention Methods

Clevis mounting is a common practice in securing rod ends in an application. Generally they are assembled into the clevis (or yoke) with a bolt or machined pin.

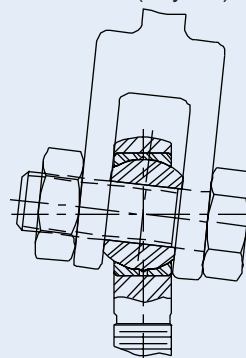

Clevis Installation

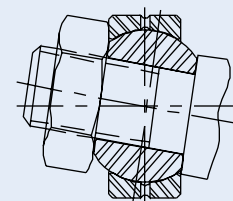

Shoulder on Shaft with lock nut

# APPLICATION, LOAD RATINGS, LUBRICATION

## Lubrication

SEALMASTER metal three-piece rod ends are greased from the factory and can be furnished with grease fittings on sizes #4 through #16 to facilitate relubrication in the field. SEALMASTER CFF/CFM two-piece rod ends are oil coated and are also available with grease fittings. SEALMASTER spherical bearings are oil coated except the stainless steel series which are dry. The BH-LS and BTS-LS Series are greased from the factory. Periodic relubrication helps prevent excessive wear, protects balls and races from corrosion, purges contamination and wear debris and helps to seal against contamination. Relubrication is recommended whenever possible for most applications. The length of interval between greasing is dependent on the application parameters and external conditions. Self-Lubricating TEFLON and DELRIN rod ends are generally used where grease relubrication is not practical or desirable.

Zerk type threaded grease fittings (designated as "N" suffix) are available on all rod end series except for TEFLON and DELRIN. Replacement grease fittings can be ordered by identifying the appropriate rod end series and size.

**Caution:** Catalog load ratings of rod ends are not applicable when grease fittings are specified, because of the reduced cross section of the head. When selecting rod ends with grease fittings, consult our engineering department for static load capacities.

Rod ends with flush type grease fittings (designated as "FN" suffix) are available on special order. (See page 173.)

SEALMASTER spherical bearings are manufactured with two lubrication systems which provide a path for lubrication to the ball and race area.

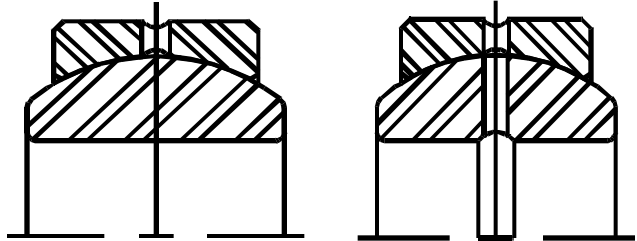

Outer races are manufactured with lubrication grooves and an interconnecting hole in the outer race to direct grease to the ball and race area.

A groove on the ball I.D. and interconnecting hole on "A" series only, directs lubrication from the shaft to the ball and race area.

Standard on the following series:

Standard on the SBG-SA sizes #8-16 only

COM	SBG-SS	BH-LS
SBG	COR	BTS-LS
SBG-S	FLBG	

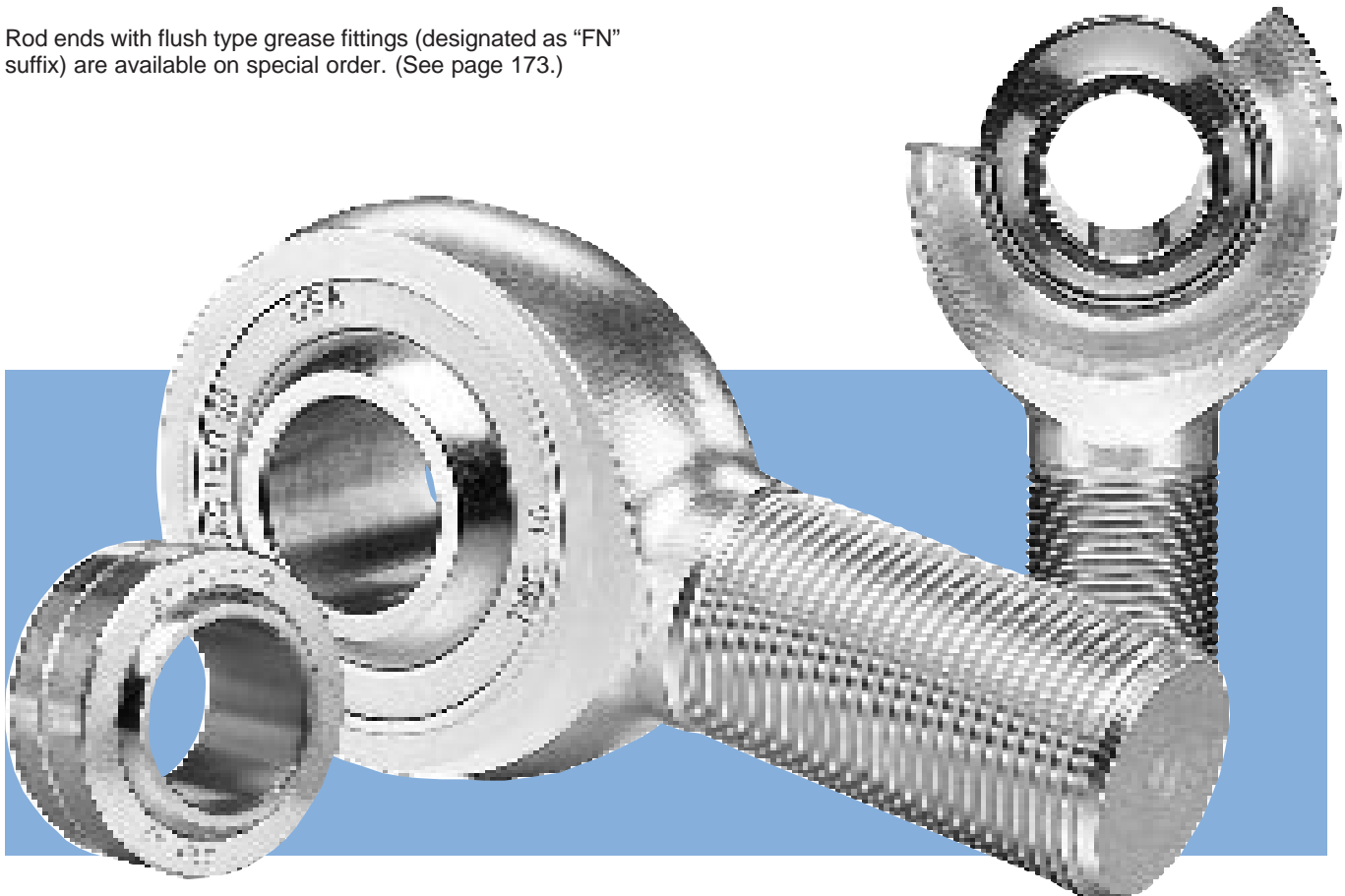

# SEALMASTER® ROD ENDS & SPHERICAL BEARINGS

## NOMENCLATURE - ROD ENDS

SEALMASTER rod end part number descriptions are called out as follows:

### TYPE OR SERIES

AR, ARE  
TR, TRE  
CFF-T, CFM-T  
TF, TM  
CFF, CFM  
CTFD, CTMD

### SIZE NUMBER

Bore size in increments of one-sixteenth (1/16) inches

### SUFFIX FOR FEATURE

(May or may not be found on all units)

20 - Large Shank  
N - Grease Fitting  
T - TEFLON Liner  
Y - Y-Stud  
# - MTO Special Designation  
R - Reverse Fitting Location with Y-Stud

### PRECISION ROD ENDS

Example: AREL-8-20N

A - Alloy Steel Outer Member  
R - Rod End  
E - External (Male) Thread  
L - Left Hand Thread  
8 - 8/16" or 1/2" Ball Bore  
20 - Large Shank (5/8")  
N - Grease Fitting

Example: TRE-8YN

T - Three-Piece  
R - Rod End  
E - External (Male) Thread  
8 - 8/16" or 1/2" Ball Bore & Thread Size  
Y - Y-Stud  
N - Grease Fitting

Example: AR-8N

A - Alloy Steel Outer Member  
R - Rod End  
8 - 8/16" or 1/2" Ball Bore & Thread Size  
N - Grease Fitting

### COMMERCIAL ROD ENDS

Example: TF-10N

T - Three-Piece  
F - Female (Internal) Thread  
10 - 10/16" or 5/8" Ball Bore & Thread Size  
N - Grease Fitting

Example: CFF-6N

C - Commercial Series  
F - Female (Internal) Thread  
6 - 6/16" or 3/8" Ball Bore & Thread Size  
N - Grease Fitting

Example: CTMD-4

C - Commercial Series  
T - Three-Piece  
M - Male  
D - DELRIN Race  
4 - 4/16" or 1/4" Ball Bore & Thread Size

## NOMENCLATURE - SPHERICAL BEARINGS

SEALMASTER spherical bearing catalog part number descriptions are called out as follows:

### TYPE OR SERIES

SBG  
COM  
COR  
BTS  
BH  
FLBG

### SIZE NUMBER

Bore size in increments of one-sixteenth (1/16) inches

### SUFFIX FOR FEATURE

(May or may not be found on all units)

S - 4130 H.T. Steel Race  
SS - Stainless Steel Race and Ball  
A - Groove on Ball I.D. and Interconnecting Hole  
LS - Low Carbon Steel Race  
# - MTO Special Designation

### PRECISION SPHERICAL BEARINGS

Example: SBG-14

S - Spherical  
B - Bearing  
G - Grooved (Race O.D.)  
14 - 14/16" or 7/8" Ball Bore

Example: SBG-16S

S - Spherical  
B - Bearing  
G - Grooved (Race O.D.)  
16 - 16/16" or 1" Ball Bore  
S - 4130 H.T. Steel Race

Example: SBG-5SS

S - Spherical  
B - Bearing  
G - Grooved (Race O.D.)  
5 - 5/16" Ball Bore  
SS - Stainless Steel Race and Ball

Example: COR-12

C - Corrosion Series  
O - Corrosion Series  
R - 12 - 12/16" or 3/4" Ball Bore

Example: BTS-20LS

B - Bellows  
T - Type  
S - Seal  
2 - 20 - 20/16" or 1 1/4" Ball Bore  
LS - Low Carbon Steel Race

Example: BH-32LS

B - Bearing  
H - Heavy Duty  
32 - 32/16" or 2" Ball Bore  
LS - Low Carbon Steel Race

### COMMERCIAL SPHERICAL BEARINGS

Example: COM-3

C - Commercial Series  
O - Commercial Series  
M - 3 - 3/16" Ball Bore

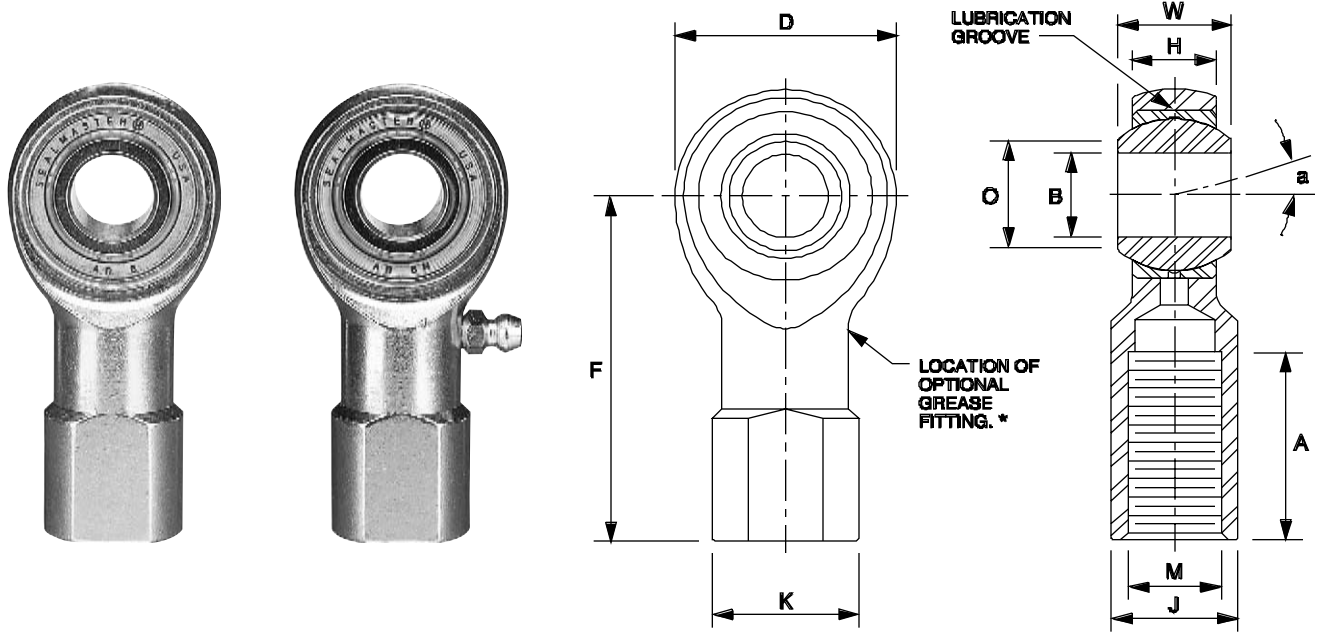

## AR,AR-N Series Three-Piece Precision Extra Capacity Female Rod

PART NUMBER	BORE B +.0015 -.0005	BALL WIDTH W +.000 -.005	HOUSING WIDTH H +.005 -.005	HEAD DIA. D +.010 -.010	LENGTH TO CTR. OF BALL F +.010 -.010	THREAD LENGTH A MIN.	THREAD SIZE M CLASS UNF-3B	BASE DIA. K REF.	ACROSS WRENCH FLATS J +.010 -.010	BALL DIA. REF.	BALL FLAT DIA. O REF.	MAX. STATIC RADIAL LOAD LBS.	MIS-ALIGNMENT ANGLE a DEG. +/-	APPROX. WEIGHT LBS.
AR-3	.1900	.312	.250	.625	1.062	.531	#10-32	.375	.312	.437	.306	3,700	6½	.03
AR-4	.2500	.375	.281	.750	1.312	.719	¼-28	.469	.375	.500	.331	5,370	8	.06
AR-5	.3125	.437	.344	.875	1.375	.719	⅜-24	.531	.437	.625	.447	7,500	7	.08
AR-6	.3750	.500	.406	1.000	1.625	.906	⅜-24	.688	.562	.718	.517	9,570	6	.14
AR-7	.4375	.562	.437	1.125	1.812	1.031	7/16-20	.750	.625	.812	.586	11,000	7	.18
AR-8	.5000	.625	.500	1.312	2.125	1.156	½-20	.875	.750	.937	.698	13,500	6	.29
AR-10	.6250	.750	.562	1.500	2.500	1.469	⅝-18	1.000	.875	1.125	.839	17,300	8	.43
AR-12	.7500	.875	.687	1.750	2.875	1.719	¾-16	1.125	1.000	1.312	.978	23,200	7	.64

AR and AR-N series extra capacity female rod ends are manufactured with an alloy steel heat treated outer member to produce higher static load ratings. This series is intended for heavier duty applications such as linkages on hoists and cranes or on the ends of hydraulic cylinder connectors.

**MATERIAL SPECIFICATIONS**  
**OUTER MEMBER - 4130 Alloy steel, heat treated, with protective plating for corrosion resistance**  
**RACE - Carbon steel with protective plating for corrosion resistance**  
**BALL - Alloy steel, heat treated, chrome plated**

- NOTES**
- \*1. Rod ends with Zerk type grease fittings can be obtained by ordering the AR-N series; Example: AR-8N.
  - Grease fittings are available on sizes 4 through 12 only.
  - Optional flush type fittings are available on special order by adding "FN" suffix to the part numbers; Example: AR-8FN.
  - Load ratings apply to the AR series only. For AR-N load ratings contact engineering.
  - This series is magnetic particle inspected upon request only.
  - To order left hand threaded units add letter "L" to part number prefix; Example: ARL-8.
  - For design modifications, see page 173.

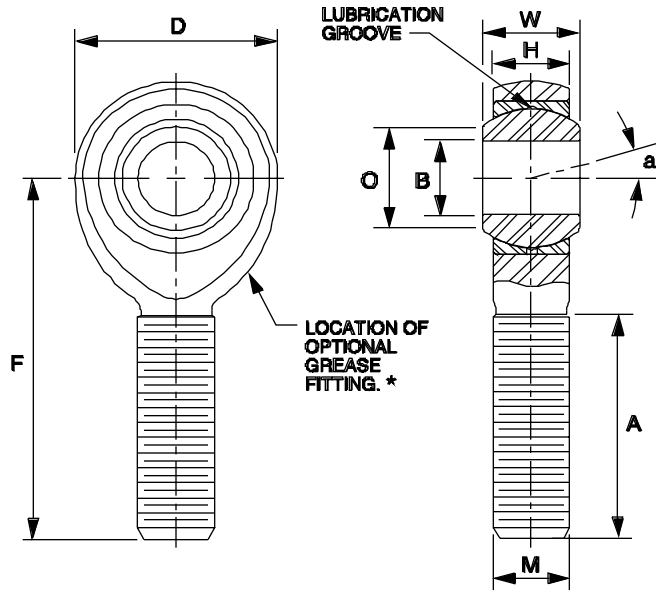

## ARE, ARE-N Series Three-Piece Precision Extra Capacity Male Rod Ends

PART NUMBER	BORE B +.0015 -.0005	BALL WIDTH W +.000 -.005	HOUSING WIDTH H +.005 -.005	HEAD DIA. D +.010 -.010	LENGTH TO CTR. OF BALL F +.010 -.010	THREAD LENGTH A MIN.	THREAD SIZE M CLASS UNF-3A	BALL DIA. REF.	BALL FLAT DIA. O REF.	MAX. STATIC RADIAL LOAD LBS.	MIS-ALIGNMENT ANGLE a DEG. +/-	APPROX. WEIGHT LBS.
ARE-3	.1900	.312	.250	.625	1.250	.719	#10-32	.437	.306	2,850	6 1/2	.03
ARE-4	.2500	.375	.281	.750	1.562	.969	1/4-28	.500	.331	4,480	8	.05
ARE-5	.3125	.437	.344	.875	1.875	1.219	5/16-24	.625	.447	7,280	7	.08
ARE-6	.3750	.500	.406	1.000	1.938	1.219	3/8-24	.718	.517	9,580	6	.12
ARE-7	.4375	.562	.437	1.125	2.125	1.344	7/16-20	.812	.586	11,000	7	.17
ARE-8	.5000	.625	.500	1.312	2.438	1.469	1/2-20	.937	.698	13,500	6	.26
ARE-10	.6250	.750	.562	1.500	2.625	1.594	5/8-18	1.125	.839	17,300	8	.41
ARE-12	.7500	.875	.687	1.750	2.875	1.719	3/4-16	1.312	.978	23,200	7	.64

ARE and ARE-N extra capacity male rod ends are manufactured with an alloy steel heat treated outer member to produce higher static load ratings. This series is intended for heavier duty applications such as linkages on hoists and cranes or on hydraulic cylinder connectors.

### MATERIAL SPECIFICATIONS

**OUTER MEMBER - 4130 Alloy steel, heat treated, with protective plating for corrosion resistance**

**RACE - Carbon steel with protective plating for corrosion resistance**

**BALL - Alloy steel, heat treated, chrome plated**

### NOTES

- \*1. Rod ends with Zerk type grease fittings can be obtained by ordering the ARE-N series; Example: ARE-8N.
2. Grease fittings are available on sizes 4 through 12 only.
3. Optional flush type fittings are available on special order by adding "FN" suffix to the part numbers; Example: ARE-8FN.
4. Load ratings apply to the ARE series only. For ARE-N load ratings contact engineering.
5. This series is magnetic particle inspected upon request only.
6. To order left hand threaded units add letter "L" to part number prefix; Example: AREL-8.
7. For design modifications, see page 173.

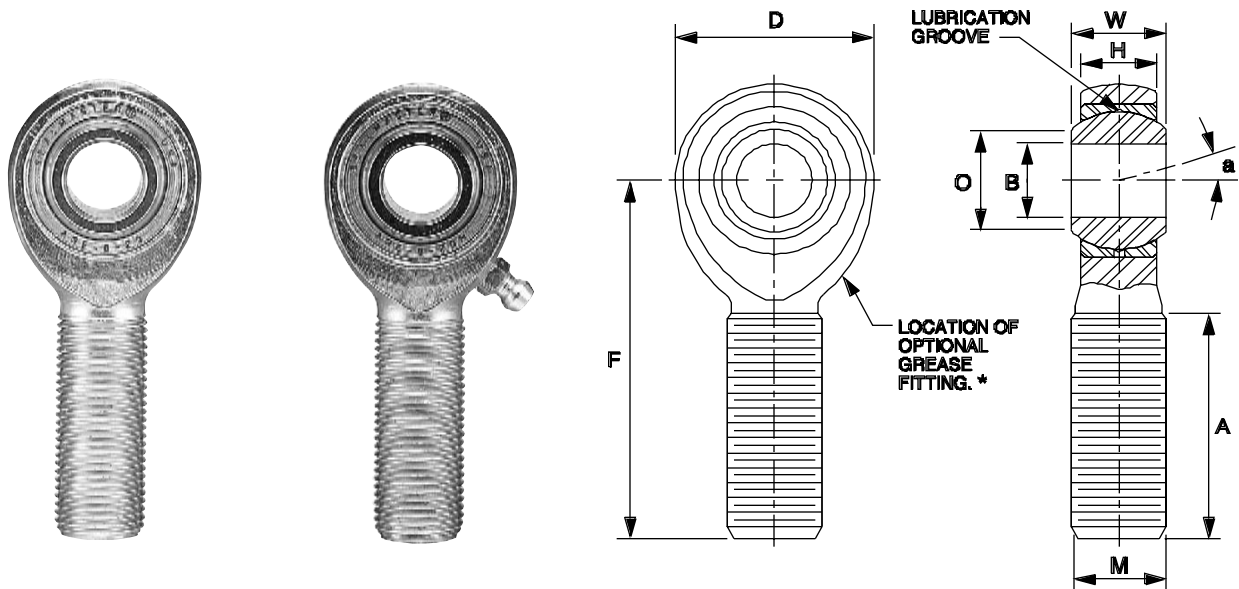

## ARE-20, ARE-20N Series Three-Piece Precision Extra Capacity Male Rod Ends

PART NUMBER	BORE B +.0015 -.0005	BALL WIDTH W +.000 -.005	HOUSING WIDTH H +.005 -.005	HEAD DIA. D +.010 -.010	LENGTH TO CTR. OF BALL F +.010 -.010	THREAD LENGTH A MIN.	THREAD SIZE M CLASS UNF-3A	BALL DIA. REF.	BALL FLAT DIA. O REF.	MAX. STATIC RADIAL LOAD LBS.	MIS-ALIGNMENT ANGLE a DEG. +/-	APPROX. WEIGHT LBS.
ARE-3-20	.1900	.312	.250	.625	1.250	.719	1/4-28	.437	.306	3,700	6 1/2	.03
ARE-4-20	.2500	.375	.281	.750	1.562	.969	5/16-24	.500	.331	5,370	8	.06
ARE-5-20	.3125	.437	.344	.875	1.875	1.219	3/8-24	.625	.447	7,500	7	.09
ARE-6-20	.3750	.500	.406	1.000	1.938	1.219	7/16-20	.718	.517	9,570	6	.13
ARE-7-20	.4375	.562	.437	1.125	2.125	1.344	1/2-20	.812	.586	11,000	7	.18
ARE-8-20	.5000	.625	.500	1.312	2.438	1.469	5/8-18	.937	.698	13,500	6	.30
ARE-10-20	.6250	.750	.562	1.500	2.625	1.594	3/4-16	1.125	.839	17,300	8	.46
ARE-12-20	.7500	.875	.687	1.750	2.875	1.719	7/8-14	1.312	.978	23,200	7	.72

ARE-20 and ARE-20N extra capacity male rod ends are manufactured with an alloy steel heat treated outer member to produce higher static load ratings. This series has oversize shanks (larger threads compared to the bore size) for additional shank strength. This series is intended for heavier duty applications such as linkages on hoists and cranes or on hydraulic cylinder connectors.

### MATERIAL SPECIFICATIONS

**OUTER MEMBER** - 4130 Alloy steel, heat treated, with protective plating for corrosion resistance  
**RACE** - Carbon steel with protective plating for corrosion resistance  
**BALL** - Alloy steel, heat treated, chrome plated

### NOTES

- \*1. Rod ends with Zerk type grease fittings can be obtained by ordering the ARE-20N series; Example: ARE-8-20N.
- Grease fittings are available on sizes 4 through 12 only.
- Optional flush type fittings are available on special order by adding "FN" suffix to the part numbers; Example: ARE-8-20FN.
- Load ratings apply to the ARE-20 series only. For ARE-20N load ratings contact engineering.
- This series is magnetic particle inspected upon request only.
- To order left hand threaded units add letter "L" to part number prefix; Example: AREL-8-20.
- For design modifications, see page 173.



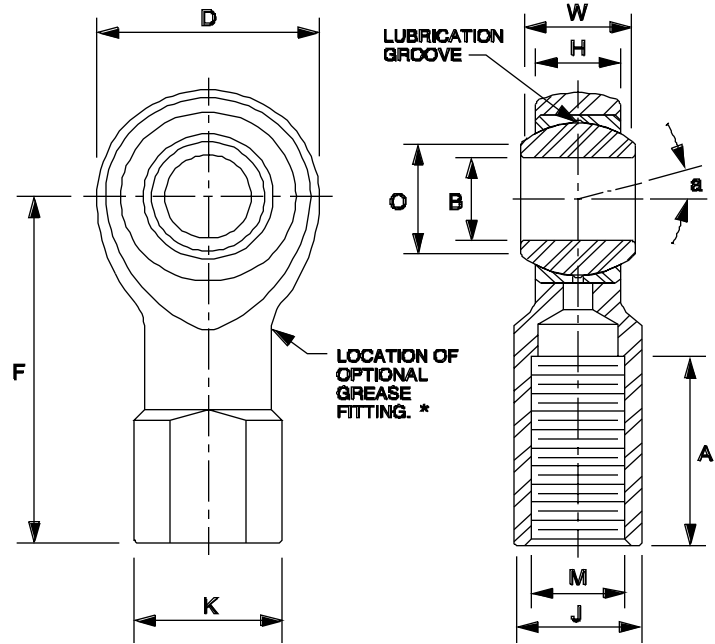

## TR, TR-N Series Three-Piece Precision Female Rod Ends

PART NUMBER	BORE B +.0015 -.0005	BALL WIDTH W +.000 -.005	HOUSING WIDTH H +.005 -.005	HEAD DIA. D +.010 -.010	LENGTH TO CTR. OF BALL F +.015 -.015	THREAD LENGTH A MIN.	THREAD SIZE M CLASS UNF-2B	BASE DIA. K REF.	ACROSS WRENCH FLATS J +.010 -.010	BALL DIA. REF.	BALL FLAT DIA. O REF.	MAX. STATIC RADIAL LOAD LBS.	MIS-ALIGNMENT ANGLE a DEG. +/-	APPROX. WEIGHT LBS.
TR-3	.1900	.312	.250	.625	1.062	.531	#10-32	.375	.312	.437	.306	1,850	6½	.03
TR-4	.2500	.375	.281	.750	1.312	.719	¼-28	.469	.375	.500	.331	2,700	8	.06
TR-5	.3125	.437	.344	.875	1.375	.719	⅜-24	.531	.437	.625	.447	3,350	7	.08
TR-6	.3750	.500	.406	1.000	1.625	.906	⅜-24	.688	.562	.718	.517	4,450	6	.14
TR-7	.4375	.562	.437	1.125	1.812	1.031	7/16-20	.750	.625	.812	.586	5,350	7	.18
TR-8	.5000	.625	.500	1.312	2.125	1.156	½-20	.875	.750	.937	.698	7,400	6	.29
TR-10	.6250	.750	.562	1.500	2.500	1.469	⅝-18	1.000	.875	1.125	.839	8,050	8	.43
TR-12	.7500	.875	.687	1.750	2.875	1.719	¾-16	1.125	1.000	1.312	.978	11,300	7	.64
** TR-16	1.0000	1.375	1.000	2.750	4.125	2.094	1¼-12	1.688	1.500	1.875	1.269	21,000	8½	2.25

TR and TR-N precision series female rod ends are a popular choice for general industrial applications, including control linkages in packaging, printing, material handling, actuators and bag closures, etc.

### MATERIAL SPECIFICATIONS

**OUTER MEMBER** - Carbon steel with protective plating for corrosion resistance

**RACE** - Carbon steel with protective plating for corrosion resistance

**BALL** - Alloy steel, heat treated, chrome plated

### NOTES

- \* 1. Rod ends with Zerk type grease fittings can be obtained by ordering the TR-N series; Example: TR-8N.
- 2. Grease fittings are available on sizes 4 through 16 only.
- 3. Optional flush type fittings are available on special order by adding "FN" suffix to the part numbers; Example: TR-8FN.
- 4. Load ratings apply to the TR series only. For TR-N load ratings contact engineering.
- 5. To order left hand threaded units add letter "L" to part number prefix; Example: TRL-8.
- 6. Add letter "Y" to the part number suffix to indicate stud. Example: TR-8Y.
- 7. For design modifications, see page 173.
- \*\* 8. Tolerances for "D" Dimension is +.030, -.010. For "H" Dimension is +.030, -.010.

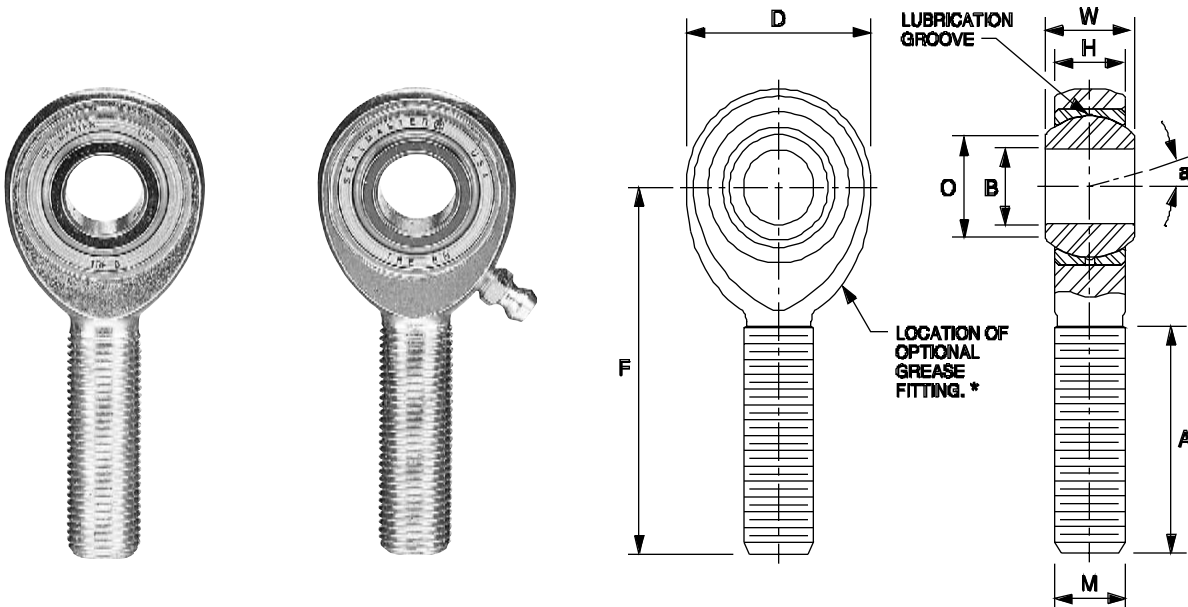

## TRE, TRE-N Series Three-Piece Precision Male Rod Ends

PART NUMBER	BORE B +.0015 -.0005	BALL WIDTH W +.000 -.005	HOUSING WIDTH H +.005 -.005	HEAD DIA. D +.010 -.010	LENGTH TO CTR. OF BALL F +.015 -.015	THREAD LENGTH A MIN.	THREAD SIZE M CLASS UNF-3A	BALL DIA. REF.	BALL FLAT DIA. O REF.	MAX. STATIC RADIAL LOAD LBS.	MIS-ALIGNMENT ANGLE a DEG. +/-	APPROX. WEIGHT LBS.
TRE-3	.1900	.312	.250	.625	1.250	.719	#10-32	.437	.306	900	6 1/2	.03
TRE-4	.2500	.375	.281	.750	1.562	.969	1/4-28	.500	.331	1,700	8	.05
TRE-5	.3125	.437	.344	.875	1.875	1.219	3/16-24	.625	.447	2,500	7	.08
TRE-6	.3750	.500	.406	1.000	1.938	1.219	3/8-24	.718	.517	4,000	6	.12
TRE-7	.4375	.562	.437	1.125	2.125	1.344	7/16-20	.812	.586	5,000	7	.17
TRE-8	.5000	.625	.500	1.312	2.438	1.469	1/2-20	.937	.698	7,000	6	.26
TRE-10	.6250	.750	.562	1.500	2.625	1.594	5/8-18	1.125	.839	8,050	8	.41
TRE-12	.7500	.875	.687	1.750	2.875	1.719	3/4-16	1.312	.978	11,300	7	.64
** TRE-16	1.0000	1.375	1.000	2.750	4.125	2.094	1 1/4-12	1.875	1.269	21,000	8 1/2	2.25

TRE and TRE-N precision series male rod ends are a popular choice for general industrial applications, including control linkages in packaging, printing, material handling, actuators and bag closures, etc.

### MATERIAL SPECIFICATIONS

**OUTER MEMBER** - Carbon steel with protective plating for corrosion resistance

**RACE** - Carbon steel with protective plating for corrosion resistance

**BALL** - Alloy steel, heat treated, chrome plated

### NOTES

- \* 1. Rod ends with Zerk type grease fittings can be obtained by ordering the TRE-N series; Example: TRE-8N.
2. Grease fittings are available on sizes 4 through 16 only.
3. Optional flush type fittings are available on special order by adding "FN" suffix to the part numbers; Example: TRE-8FN.
4. Load ratings apply to the TRE series only. For TRE-N load ratings contact engineering.
5. To order left hand threaded units add letter "L" to part number prefix; Example: TREL-8.
6. Add letter "Y" to the part number suffix to indicate stud; Example: TRE-8Y.
7. For design modifications, see page 173.
- \*\* 8. Tolerances for "D" Dimension is +.030, -.010. For "H" Dimension is +.030, -.010.

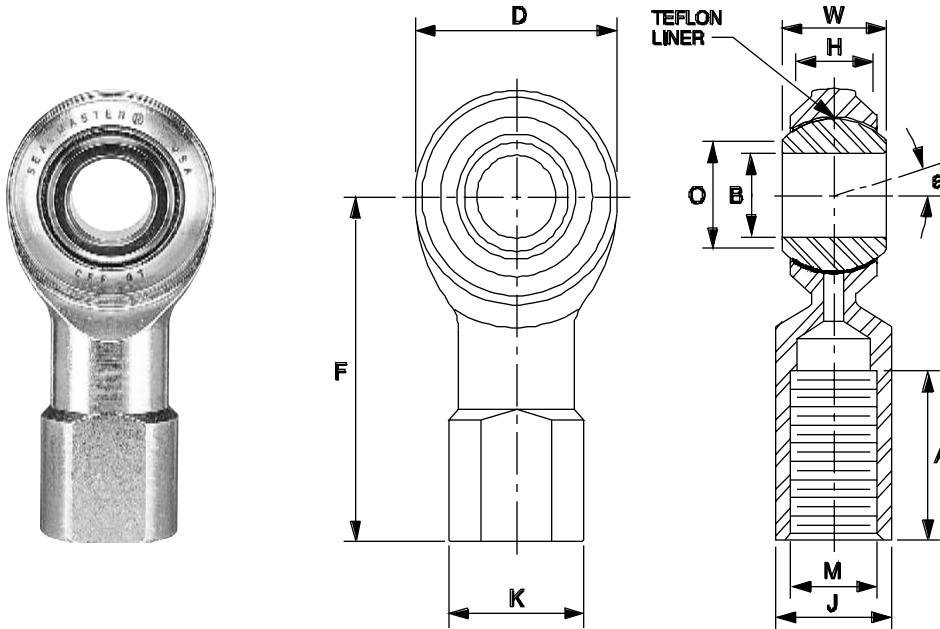

## CFF-T Series Two-Piece Precision Female Rod Ends - Self Lubricating Teflon Lined

PART NUMBER	BORE B +.0015 -.0005	BALL WIDTH W +.000 -.005	HOUSING WIDTH H REF.	HEAD DIA. D +.031 -.031	LENGTH TO CTR. OF BALL F +.015 -.015	THREAD LENGTH A MIN.	THREAD SIZE M CLASS UNF-2B	BASE DIA. K REF.	ACROSS WRENCH FLATS J +.010 -.010	BALL DIA. REF.	BALL FLAT DIA. O REF.	MAX. STATIC RADIAL LOAD LBS.	MIS-ALIGNMENT ANGLE a DEG. +/-	APPROX. WEIGHT LBS.
CFF-3T	.1900	.312	.250	.625	1.062	.469	#10-32	.375	.312	.437	.306	865	6 1/2	.03
CFF-4T	.2500	.375	.281	.750	1.312	.656	1/4-28	.469	.375	.500	.331	1,550	8	.06
CFF-5T	.3125	.437	.344	.875	1.375	.656	5/16-24	.531	.437	.625	.447	2,080	7	.08
CFF-6T	.3750	.500	.406	1.000	1.625	.781	3/8-24	.688	.562	.718	.517	2,950	6	.14
CFF-7T	.4375	.562	.437	1.125	1.812	.906	7/16-20	.750	.625	.812	.586	3,160	7	.18
CFF-8T	.5000	.625	.500	1.312	2.125	1.031	1/2-20	.875	.750	.937	.698	4,920	6	.29
CFF-10T	.6250	.750	.562	1.500	2.500	1.344	5/8-18	1.000	.875	1.125	.839	5,460	8	.43
CFF-12T	.7500	.875	.687	1.750	2.875	1.531	3/4-16	1.125	1.000	1.312	.978	8,300	7	.64
CFF-16T	1.0000	1.375	1.000	2.750	4.125	2.000	1 1/4-12	1.688	1.500	1.875	1.269	21,000	8 1/2	2.25

CFF-T precision series female rod ends combine the strength of two-piece design and self-lubricating TEFLON for use in a wide variety of applications. These self-lubricating rod ends are used where grease relubrication is not practical or desirable and operate to 250 degrees F in normal industrial applications. A hardened steel chrome plated ball moving against a TEFLON fabric liner results in smooth operation and longer wear when compared with most metal-metal units. CFF-T rod ends are manufactured with consistent no load rotational torque values making them a popular choice in carton folding, book binding, and printing equipment applications, etc., where close tolerances and accurate linkage control are important.

### MATERIAL SPECIFICATIONS

- OUTER MEMBER - Carbon steel with protective plating for corrosion resistance**
- BALL - Alloy steel, heat treated, chrome plated**
- LINER - Teflon fabric**

### NOTES

1. To order left hand threaded units add letter "L" to part number prefix; Example: CFFL-8T.
2. "T" in part number prefix indicates TEFLON liner.
3. Add letter "Y" to the part number suffix to indicate stud; Example: CFF-8TY.
4. For design modifications, see page 173.

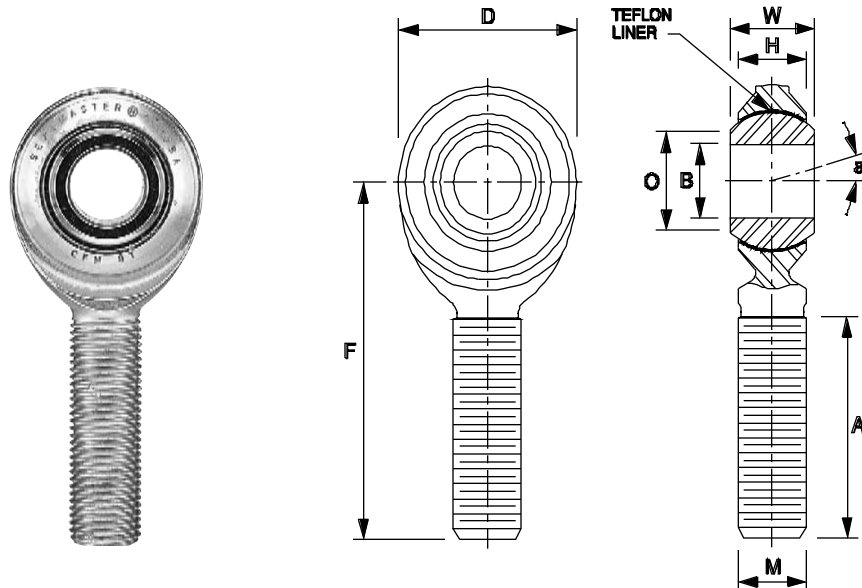

## CFM-T Series Two-Piece Precision Male Rod Ends - Self Lubricating Teflon Lined

PART NUMBER	BORE B +.0015 -.0005	BALL WIDTH W +.000 -.005	HOUSING WIDTH H REF.	HEAD DIA. D +.031 -.031	LENGTH TO CTR. OF BALL F +.015 -.015	THREAD LENGTH A MIN.	THREAD SIZE M CLASS UNF-3A	BALL DIA. REF.	BALL FLAT DIA. O REF.	MAX. STATIC RADIAL LOAD LBS.	MIS-ALIGNMENT ANGLE a DEG. +/-	APPROX. WEIGHT LBS.
CFM-3T	.1900	.312	.250	.625	1.250	.719	#10-32	.437	.306	865	6 1/2	.03
CFM-4T	.2500	.375	.281	.750	1.562	.969	1/4-28	.500	.331	1,550	8	.05
CFM-5T	.3125	.437	.344	.875	1.875	1.219	5/16-24	.625	.447	2,080	7	.08
CFM-6T	.3750	.500	.406	1.000	1.938	1.219	3/8-24	.718	.517	2,950	6	.12
CFM-7T	.4375	.562	.437	1.125	2.125	1.344	7/16-20	.812	.586	3,160	7	.17
CFM-8T	.5000	.625	.500	1.312	2.438	1.469	1/2-20	.937	.698	4,920	6	.26
CFM-10T	.6250	.750	.562	1.500	2.625	1.594	5/8-18	1.125	.839	5,460	8	.41
CFM-12T	.7500	.875	.687	1.750	2.875	1.719	3/4-16	1.312	.978	8,300	7	.64
CFM-16T	1.0000	1.375	1.000	2.750	4.125	2.094	1 1/4-12	1.875	1.269	21,000	8 1/2	2.25

CFM-T precision series male rod ends combine the strength of two-piece design and self-lubricating TEFLON for use in a wide variety of applications. These self-lubricating rod ends are used where grease relubrication is not practical or desirable and operate to 250 degrees F in normal industrial applications. A hardened steel chrome plated ball moving against a TEFLON fabric liner results in smooth operation and longer wear when compared with most metal-metal units. CFM-T rod ends are manufactured with consistent no load rotational torque values making them a popular choice in carton folding, book binding, and printing equipment applications, etc., where close tolerances and accurate linkage control are important.

### MATERIAL SPECIFICATIONS

**OUTER MEMBER - Carbon steel with protective plating for corrosion resistance**

**BALL - Alloy steel, heat treated, chrome plated**

**LINER - Teflon fabric**

### NOTES

1. To order left hand threaded units add letter "L" to part number prefix. Example: CFML-8T.
2. "T" in part number prefix indicates TEFLON liner.
3. Add letter "Y" to the part number suffix to indicate stud; Example: CFM-8TY.
4. For design modifications, see page 173.

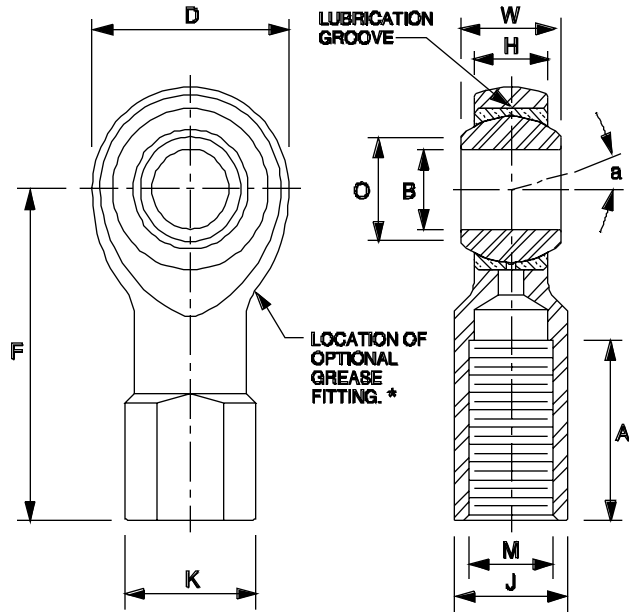

## TF, TF-N Series Three-Piece Commercial Female Rod Ends

PART NUMBER	BORE B +0.025 -0.005	BALL WIDTH W +0.005 -0.005	HOUSING WIDTH H +0.010 -0.010	HEAD DIA. D +0.031 -0.031	LENGTH TO CTR. OF BALL F REF.	THREAD LENGTH A MIN.	THREAD SIZE M CLASS UNF-2B	BASE DIA. K REF.	ACROSS WRENCH FLATS J +0.010 -0.010	BALL DIA. O REF.	BALL FLAT DIA. O REF.	MAX. STATIC RADIAL LOAD LBS.	MIS-ALIGNMENT ANGLE a DEG. +/-	APPROX. WEIGHT LBS.
TF-3	.1900	.312	.250	.625	1.062	.531	#10-32	.375	.312	.437	.306	1,850	6 1/2	.03
TF-4	.2500	.375	.281	.750	1.312	.719	1/4-28	.469	.375	.500	.331	2,700	8	.06
TF-5	.3125	.437	.344	.875	1.375	.719	3/8-24	.531	.437	.625	.447	3,350	7	.08
TF-6	.3750	.500	.406	1.000	1.625	.906	1/2-24	.688	.562	.718	.517	4,450	6	.14
TF-7	.4375	.562	.437	1.125	1.812	1.031	7/8-20	.750	.625	.812	.586	5,350	7	.18
TF-8	.5000	.625	.500	1.312	2.125	1.156	1 1/2-20	.875	.750	.937	.698	7,400	6	.29
TF-10	.6250	.750	.562	1.500	2.500	1.469	3/4-18	1.000	.875	1.125	.839	8,050	8	.43
TF-12	.7500	.875	.687	1.750	2.875	1.719	3/4-16	1.125	1.000	1.312	.978	11,300	7	.64

TF and TF-N commercial series female three-piece rod ends are machined from carbon steel and feature one-piece bronze races for lower friction and longer wear.

### MATERIAL SPECIFICATIONS

**OUTER MEMBER - Low carbon steel with protective plating for corrosion resistance**  
**RACE - Bronze**  
**BALL - Alloy steel, heat treated, chrome plated**

### NOTES

- \* 1. Rod ends with Zerk type grease fittings can be obtained by ordering the TF-N series; Example: TF-8N.
2. Grease fittings are available on sizes 4 through 12 only.
3. Optional flush type fittings are available on special order by adding "FN" suffix to the part numbers; Example: TF-8FN.
4. Load ratings apply to the TF series only. For TF-N load ratings contact engineering.
5. To order left hand threaded units add letter "L" to part number prefix; Example: TFL-8.
6. Add letter "Y" to the part number suffix to indicate stud; Example: TF-8Y.
7. For design modifications, see page 173.

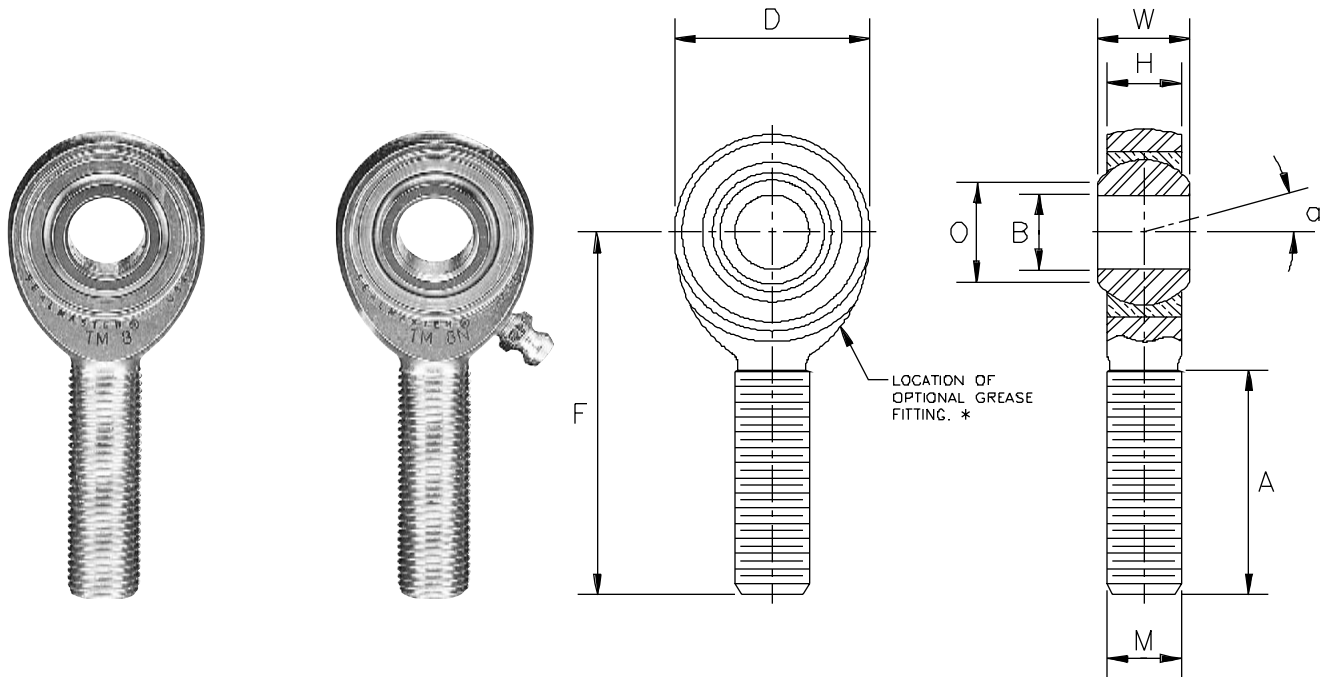

## TM, TM-N Series Three-Piece Commercial Male Rod Ends

PART NUMBER	BORE B +.0025 -.0005	BALL WIDTH W +.005 -.005	HOUSING WIDTH H +.010 -.010	HEAD DIA. D +.031 -.031	LENGTH TO CTR. OF BALL F REF.	THREAD LENGTH A MIN.	THREAD SIZE M CLASS UNF-3A	BALL DIA. REF.	BALL FLAT DIA. O REF.	MAX. STATIC RADIAL LOAD LBS.	MIS-ALIGNMENT ANGLE a DEG. +/-	APPROX. WEIGHT LBS.
TM-3	.1900	.312	.250	.625	1.250	.719	#10-32	.437	.306	900	6½	.03
TM-4	.2500	.375	.281	.750	1.562	.969	¼-28	.500	.331	1,700	8	.05
TM-5	.3125	.437	.344	.875	1.875	1.219	⅜-24	.625	.447	2,500	7	.08
TM-6	.3750	.500	.406	1.000	1.938	1.219	⅜-24	.718	.517	4,000	6	.12
TM-7	.4375	.562	.437	1.125	2.125	1.344	7/16-20	.812	.586	5,000	7	.17
TM-8	.5000	.625	.500	1.312	2.438	1.469	½-20	.937	.698	7,000	6	.26
TM-10	.6250	.750	.562	1.500	2.625	1.594	⅝-18	1.125	.839	8,050	8	.41
TM-12	.7500	.875	.687	1.750	2.875	1.719	¾-16	1.312	.978	11,300	7	.64

TM and TM-N commercial series male three-piece rod ends are machined from carbon steel and feature one-piece bronze races for lower friction and longer wear.

### MATERIAL SPECIFICATIONS

**OUTER MEMBER - Carbon steel with protective plating for corrosion resistance**

**RACE - Bronze**

**BALL - Alloy steel, heat treated, chrome plated**

### NOTES

- \* 1. Rod ends with Zerk type grease fittings can be obtained by ordering the TM-N series; Example: TM-8N.
2. Grease fittings are available on sizes 4 through 12 only.
3. Optional flush type fittings are available on special order by adding "FN" suffix to the part numbers; Example: TM-8FN.
4. Load ratings apply to the TM series only. For TM-N load ratings contact engineering.
5. To order left hand threaded units add letter "L" to part number prefix; Example: TML-8.
6. Add letter "Y" to the part number suffix to indicate stud; Example: TM-8Y.
7. For design modifications, see page 173.

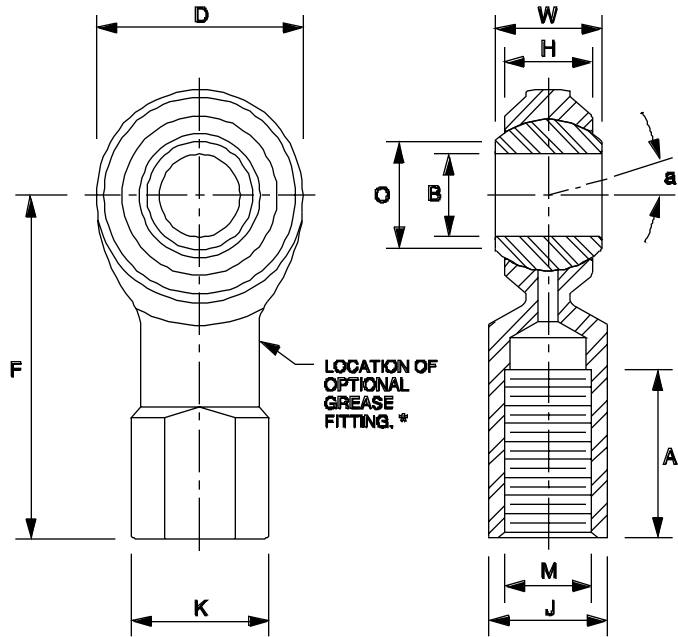

## CFF, CFF-N Series Two-Piece Commercial Female Rod Ends

PART NUMBER	BORE B +.0025 -.0005	BALL WIDTH W +.005 -.005	HOUSING WIDTH H REF.	HEAD DIA. D +.031 -.031	LENGTH TO CTR. OF BALL F REF.	THREAD LENGTH A MIN.	THREAD SIZE M CLASS UNF-2B	BASE DIA. K REF.	ACROSS WRENCH FLATS J +.010 -.010	BALL DIA. REF.	BALL FLAT DIA. O REF.	MAX. STATIC RADIAL LOAD LBS.	MIS-ALIGNMENT ANGLE a DEG. +/-	APPROX. WEIGHT LBS.
CFF-3	.1900	.312	.250	.625	1.062	.469	#10-32	.375	.312	.437	.306	2,000	6 1/2	.03
CFF-4	.2500	.375	.281	.750	1.312	.656	1/4-28	.469	.375	.500	.331	3,200	8	.06
CFF-5	.3125	.437	.344	.875	1.375	.656	5/16-24	.531	.437	.625	.447	3,800	7	.08
CFF-6	.3750	.500	.406	1.000	1.625	.781	3/8-24	.688	.562	.718	.517	5,000	6	.14
CFF-7	.4375	.562	.437	1.125	1.812	.906	7/16-20	.750	.625	.812	.586	6,500	7	.18
CFF-8	.5000	.625	.500	1.312	2.125	1.031	1/2-20	.875	.750	.937	.698	9,000	6	.29
CFF-10	.6250	.750	.562	1.500	2.500	1.344	5/8-18	1.000	.875	1.125	.839	10,000	8	.43
CFF-12	.7500	.875	.687	1.750	2.875	1.531	3/4-16	1.125	1.000	1.312	.978	14,000	7	.64
CFF-16 <sup>8</sup>	1.0000	1.375	1.000	2.750	4.125	2.000	1 1/4-12	1.688	1.500	1.875	1.269	25,200	8 1/2	2.25

CFF and CFF-N female commercial rod ends combine higher strength two-piece design for heavier static loads. The two-piece design provides greater housing cross section and increased load capacity than three-piece rod ends with like housing materials. This commercial series provides a lower cost alternative for applications requiring a higher static load capacity.

**MATERIAL SPECIFICATIONS**  
**OUTER MEMBER - Carbon steel with protective plating for corrosion resistance**  
**BALL - Alloy steel, heat treated, chrome plated**

### NOTES

- \* 1. Rod ends with Zerk type grease fittings can be obtained by ordering the CFF-N series; Example: CFF-8N.
- 2. Grease fittings are available on sizes 4 through 16 only.
- 3. Optional flush type fittings are available on special order by adding "FN" suffix to the part numbers; Example: CFF-8FN.
- 4. Load ratings apply to the CFF series only. For CFF-N load ratings contact engineering.
- 5. To order left hand threaded units add letter "L" to part number prefix; Example: CFFL-8.
- 6. Add letter "Y" to the part number suffix to indicate stud; Example: CFF-8Y.
- 7. For design modifications, see page 173.
- 8. New larger size.

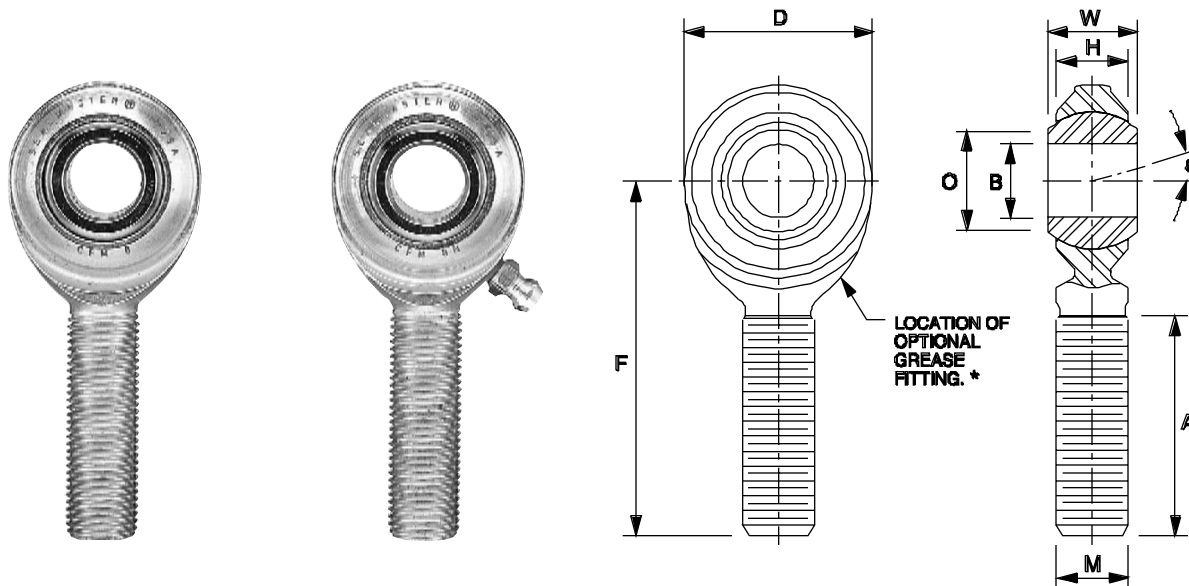

## CFM, CFM-N Series Two-Piece Commercial Male Rod Ends

PART NUMBER	BORE B +.0025 -.0005	BALL WIDTH W +.005 -.005	HOUSING WIDTH H REF.	HEAD DIA. D +.031 -.031	LENGTH TO CTR. OF BALL F REF.	THREAD LENGTH A MIN.	THREAD SIZE M CLASS UNF-3A	BALL DIA. REF.	BALL FLAT DIA. O REF.	MAX. STATIC RADIAL LOAD LBS.	MIS-ALIGNMENT ANGLE a DEG. +/-	APPROX. WEIGHT LBS.
CFM-3	.1900	.312	.250	.625	1.250	.719	#10-32	.437	.306	950	6½	.03
CFM-4	.2500	.375	.281	.750	1.562	.969	¼-28	.500	.331	2,000	8	.05
CFM-5	.3125	.437	.344	.875	1.875	1.219	⅜-24	.625	.447	3,000	7	.08
CFM-6	.3750	.500	.406	1.000	1.938	1.219	⅜-24	.718	.517	5,000	6	.11
CFM-7	.4375	.562	.437	1.125	2.125	1.344	7/16-20	.812	.586	6,500	7	.16
CFM-8	.5000	.625	.500	1.312	2.438	1.469	½-20	.937	.698	9,000	6	.24
CFM-10	.6250	.750	.562	1.500	2.625	1.594	⅝-18	1.125	.839	10,000	8	.40
CFM-12	.7500	.875	.687	1.750	2.875	1.719	¾-16	1.312	.978	14,000	7	.63
CFM-16 <sup>8</sup>	1.0000	1.375	1.000	2.750	4.125	2.094	1¼-12	1.875	1.269	25,200	8½	2.25

CFM and CFM-N male commercial rod ends combine higher strength two-piece design for heavier static loads. The two-piece design provides greater housing cross section and increased load capacity than three-piece rod ends with like housing materials. This commercial series provides a lower cost alternative for applications requiring a higher static load capacity.

**MATERIAL SPECIFICATIONS**  
**OUTER MEMBER - Carbon steel with protective plating for corrosion resistance**  
**BALL - Alloy steel, heat treated, chrome plated**

### NOTES

- \* 1. Rod ends with Zerk type grease fittings can be obtained by ordering the CFM-N series; Example: CFM-8N.
- 2. Grease fittings are available on sizes 4 through 16 only.
- 3. Optional flush type fittings are available on special order by adding "FN" suffix to the part numbers; Example: CFM-8FN.
- 4. Load ratings apply to the CFM series only. For CFM-N load ratings contact engineering.
- 5. To order left hand threaded units add letter "L" to part number prefix; Example: CFML-8.
- 6. Add letter "Y" to the part number suffix to indicate stud; Example: CFM-8Y.
- 7. For design modifications, see page 173.
- 8. New larger size.



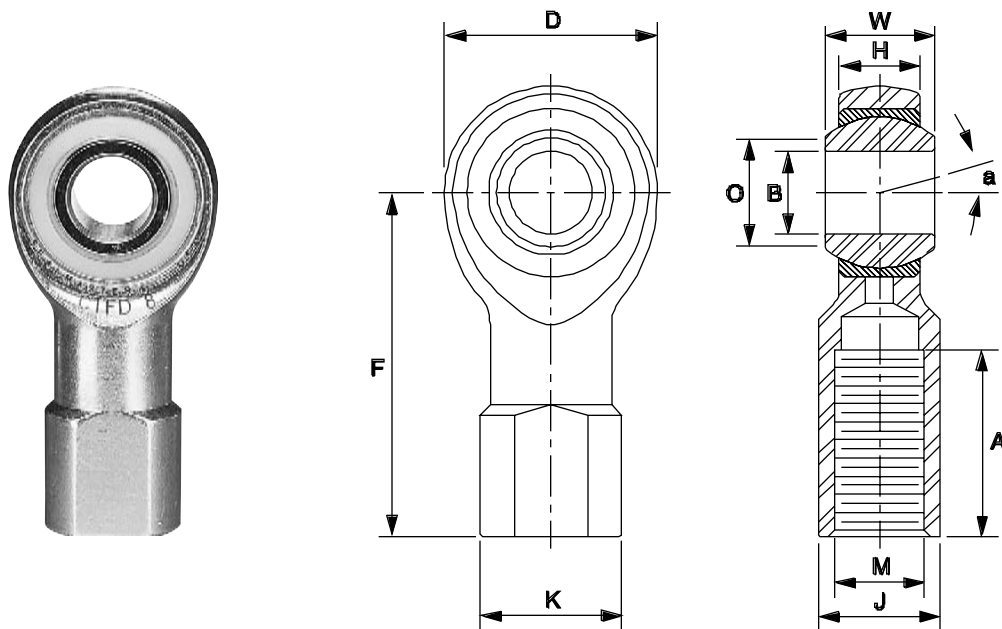

## CTFD Series Three-Piece Commercial Female Rod Ends - Self Lubricating Delrin

PART NUMBER	BORE B +.0025 -.0005	BALL WIDTH W +.005 -.005	HOUSING WIDTH H +.010 -.010	HEAD DIA. D +.031 -.031	LENGTH TO CTR. OF BALL F REF.	THREAD LENGTH A MIN.	THREAD SIZE M CLASS UNF-2B	BASE DIA. K REF.	ACROSS WRENCH FLATS J +.010 -.010	BALL DIA. REF.	BALL FLAT DIA. O REF.	MAX. STATIC RADIAL LOAD LBS.	MIS-ALIGNMENT ANGLE a DEG. +/-	APPROX. WEIGHT LBS.
CTFD-3	.1900	.312	.250	.625	1.062	.531	#10-32	.375	.312	.437	.306	800	6½	.03
CTFD-4	.2500	.375	.281	.750	1.312	.719	¼-28	.469	.375	.500	.331	1,060	8	.06
CTFD-5	.3125	.437	.344	.875	1.375	.719	⅜-24	.531	.437	.625	.447	1,570	7	.08
CTFD-6	.3750	.500	.406	1.000	1.625	.906	⅝-24	.688	.562	.718	.517	2,150	6	.14
CTFD-7	.4375	.562	.437	1.125	1.812	1.031	⅞-20	.750	.625	.812	.586	2,600	7	.18
CTFD-8	.5000	.625	.500	1.312	2.125	1.156	½-20	.875	.750	.937	.698	3,420	6	.29
CTFD-10	.6250	.750	.562	1.500	2.500	1.469	⅝-18	1.000	.875	1.125	.839	4,620	8	.43
CTFD-12	.7500	.875	.687	1.750	2.875	1.719	¾-16	1.125	1.000	1.312	.978	6,600	7	.64

CTFD commercial three-piece female rod ends feature DELRIN races for applications where oil and grease should be avoided. This maintenance-free design is a popular choice in lighter duty applications such as food processing, packaging and textile equipment.

DELIN features include:

- Lower coefficient of friction than metal-to-metal types.
- Withstands vibration without galling or fretting of the surface.
- Absorbs less moisture compared to bearings with nylon races.

### MATERIAL SPECIFICATIONS

- OUTER MEMBER - Carbon steel with protective plating for corrosion resistance
- RACE - DELRIN Acetal Resin
- BALL - Alloy steel, heat treated, chrome plated

### NOTES

- To order left hand threaded units add letter "L" to part number prefix; Example: CTFDL-8.
- Add letter "Y" to the part number suffix to indicate stud; Example: CTFD-8Y.
- For design modifications, see page 173.
- Caution: Prolonged exposure to ultraviolet light can cause loss of mechanical properties in DELRIN material. Consult our engineering department for application assistance.

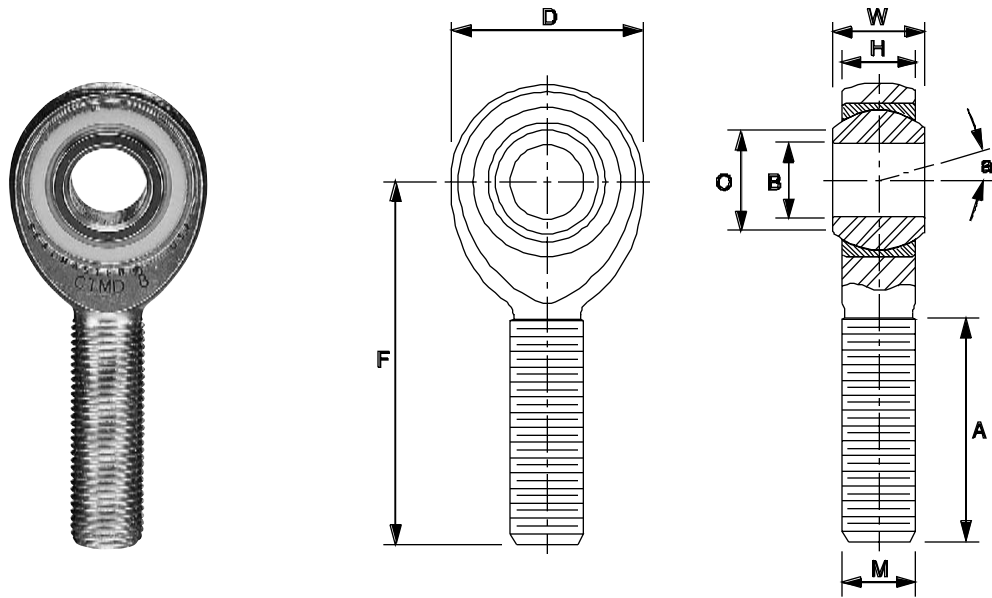

## CTMD Series Three-Piece Commercial Male Rod Ends - Self Lubricating Delrin

PART NUMBER	BORE B +.0025 -.0005	BALL WIDTH W +.005 -.005	HOUSING WIDTH H +.010 -.010	HEAD DIA. D +.031 -.031	LENGTH TO CTR. OF BALL F REF.	THREAD LENGTH A MIN.	THREAD SIZE M CLASS UNF-3A	BALL DIA. REF.	BALL FLAT DIA. O REF.	MAX. STATIC RADIAL LOAD LBS.	MIS-ALIGNMENT ANGLE a DEG. +/-	APPROX. WEIGHT LBS.
CTMD-3	.1900	.312	.250	.625	1.250	.719	#10-32	.437	.306	800	6½	.03
CTMD-4	.2500	.375	.281	.750	1.562	.969	¼-28	.500	.331	1,060	8	.05
CTMD-5	.3125	.437	.344	.875	1.875	1.219	⅜-24	.625	.447	1,570	7	.08
CTMD-6	.3750	.500	.406	1.000	1.938	1.219	⅜-24	.718	.517	2,150	6	.12
CTMD-7	.4375	.562	.437	1.125	2.125	1.344	⅞-20	.812	.586	2,600	7	.17
CTMD-8	.5000	.625	.500	1.312	2.438	1.469	½-20	.937	.698	3,420	6	.26
CTMD-10	.6250	.750	.562	1.500	2.625	1.594	⅝-18	1.125	.839	4,620	8	.41
CTMD-12	.7500	.875	.687	1.750	2.875	1.719	¾-16	1.312	.978	6,600	7	.64

CTMD commercial three-piece male rod ends feature DELRIN races for applications where oil and grease should be avoided. This maintenance-free design is a popular choice in lighter duty applications such as food processing, packaging, and textile equipment.

DELIN features include:

- Lower coefficient of friction than metal-to-metal types.
- Withstands vibration without galling or fretting of the surface.
- Absorbs less moisture compared to bearings with nylon races.

### MATERIAL SPECIFICATIONS

**OUTER MEMBER - Carbon steel with protective plating for corrosion resistance**

**RACE - DELRIN Acetal Resin**

**BALL - Alloy steel, heat treated, chrome plated**

### NOTES

- To order left hand threaded units add letter "L" to part number prefix; Example: CTMDL-8.
- Add letter "Y" to the part number suffix to indicate stud; Example: CTMD-8Y.
- For design modifications, see page 173.
- Caution: Prolonged exposure to ultraviolet light can cause loss of mechanical properties in DELRIN material. Consult our engineering department for application assistance.

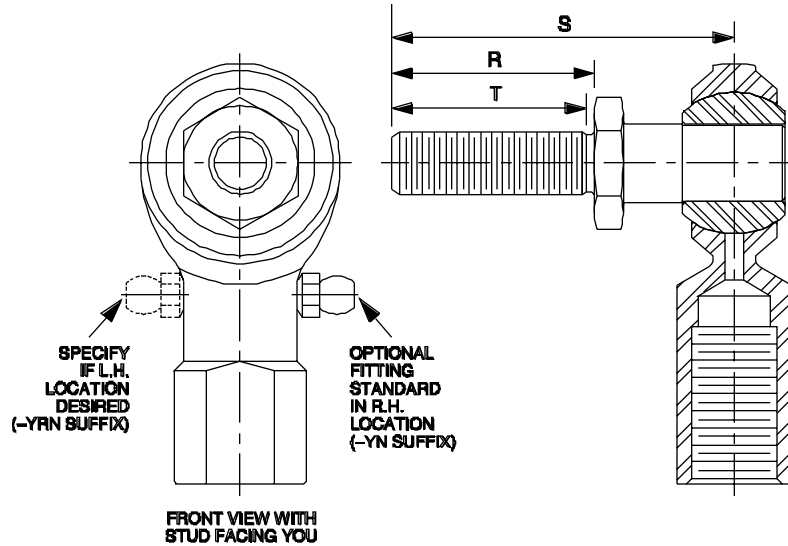

## Y-STUDS

STUD SIZE	R +.031 -.031	S +.031 -.031	T MIN.	THREAD SIZE CLASS UNF-2A
-3	.500	.968	7/16	#10-32
-4	.562	1.047	1/2	1/4-28
-5	.687	1.234	19/32	5/16-24
-6	.906	1.540	13/16	3/8-24
-7	1.125	1.930	1	7/16-20
-8	1.125	2.000	1	1/2-20
-10	1.500	2.500	1 3/8	5/8-18
-12	1.812	3.000	1 5/8	3/4-16

### AVAILABLE AS:

- TR-Y, TRE-Y SERIES
- CFF-TY, CFM-TY SERIES
- TF-Y, TM-Y SERIES
- CTFD-Y, CTMD-Y SERIES
- CFF-Y, CFM-Y SERIES

**SEALMASTER Y-studs** are available in all of the above rod end designs to facilitate right angle connections in a wide variety of linkage applications. Y-studs are manufactured from carbon steel and plated for corrosion protection. They are secured in the bore, threaded for mounting and manufactured with a hex wrench flat to accommodate tightening. Rod ends with Y-studs can accommodate up to  $\pm 25$  degrees of angular misalignment in any direction for maximum flexibility in linkage design.

To order, simply add the letter Y to the rod end part number; Example: TR-8Y.

### NOTE

Caution when selecting rod ends with Y-studs: Catalog load ratings are not applicable with Y-studs because of the reduced stud strength due to bending. For load ratings with Y-studs contact our engineering department.

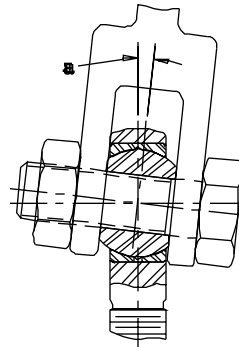

Rod End Angle:  
 $a = \sin^{-1} \frac{W}{D} - \sin^{-1} \frac{H}{D}$

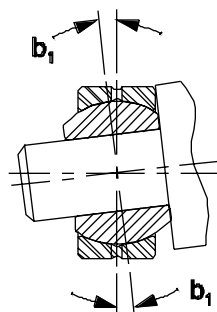

$$b_1 = \sin^{-1} \frac{W}{V} - \sin^{-1} \frac{H}{V}$$

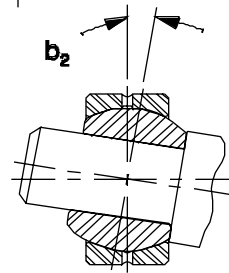

$$b_2 = \sin^{-1} \frac{W}{E} - \sin^{-1} \frac{H}{E}$$

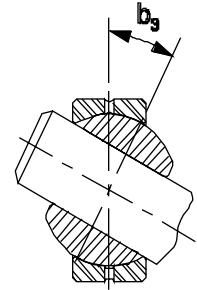

$$b_3 = \cos^{-1} \frac{B}{E} - \sin^{-1} \frac{H}{E}$$

## MISALIGNMENT CAPABILITIES

### SPHERICAL BEARINGS

SERIES SBG, SBG-S, SBG-SS, SBG-SA, COM, COR			
PART NO.	(+/-) b <sub>1</sub>	(+/-) b <sub>2</sub>	(+/-) b <sub>3</sub>
-3	7 1/2	11 1/2	29 1/2
-4	9	13 1/2	30
-5	8	12	26
-6	7 1/2	10	26 1/2
-7	6 1/2	9 1/2	20 1/2
-8	7	10	20
-10	6 1/2	9	18 1/2
-12	7	9	21
-14	7	9 1/2	16
-16	7	9 1/2	16

SERIES FLBG			
PART NO.	(+/-) b <sub>1</sub>	(+/-) b <sub>2</sub>	(+/-) b <sub>3</sub>
-3	9 1/2	16 1/2	34 1/2
-4	8	14 1/2	26
-5	9	14 1/2	30
-6	8	12 1/2	27
-7	6 1/2	11	25
-8	7 1/2	12 1/2	23
-10	7 1/2	12	23
-12	8 1/2	15	27 1/2
-16	6 1/2	10	25

SERIES BH-LS			
PART NO.	(+/-) b <sub>1</sub>	(+/-) b <sub>2</sub>	(+/-) b <sub>3</sub>
-16	6 1/2	9	26
-19	6 1/2	8 1/2	25 1/2
-20	6 1/2	8 1/2	23 1/2
-24	6	8	21 1/2
-28	6	8	20
-32	6 1/2	8 1/2	19

SERIES BTS-LS	
PART NO.	(+/-) b <sub>2</sub>
-12	13 1/2
-16	12
-20	9 1/2
-24	7 1/2

### ROD ENDS

SERIES AR, ARE, ARE-20, TR, TRE, CFF-T, CFM-T, TF, TM, CFF, CFM, CTFD, CTMD	
PART NO.	(+/-) a
-3	6 1/2
-4	8
-5	7
-6	6
-7	7
-8	6
-10	8
-12	7
-16	8 1/2

The angle of misalignment in a rod end is controlled by the outside diameter of the head and ball width. The maximum degree of misalignment is obtained when the head contacts the inside of the fork or clevis in which it is mounted. Greater than catalog misalignment can be accomplished by adding a spacer washer between the ball flat and the clevis I.D. or by selecting a rod end with a Y-Stud.

The angle of misalignment in a spherical bearing is calculated somewhat differently than a rod end. Illustrated above are common mountings for spherical bearings and the corresponding formula for calculating the angle of misalignment.

#### Reference Letters

- B = Bore of Ball
- C = Chamfer on Outer Race
- D = Head or Diameter of Outer Race
- E = Ball Diameter
- H = Housing Width
- V =  $\sqrt{(D - 2C)^2 + H^2}$
- W = Ball Width



Typical SBG Series

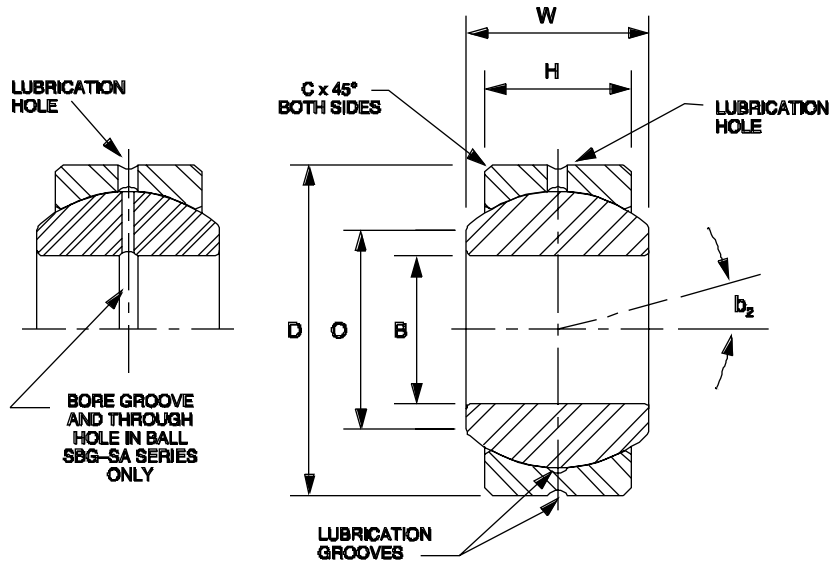

## SBG, SBG-S, SBG-SA, SBG-SS

Series Two-Piece Precision Spherical Bearings

SPHERICAL BEARING PART NUMBER				BORE B +.0000 -.0005	OUTSIDE DIA. D +.0000 -.0005	BALL WIDTH W +.000 -.005	RACE WIDTH H +.005 -.005	CHAM- FER C REF.	BALL DIA. REF.	BALL FLAT DIA. O REF.	SBG SERIES MAX. LBS.	SBG-S SERIES STATIC LBS.	SBG-SA SERIES RADIAL LBS.	SBG-SS SERIES LOAD RATING LBS.	MIS- ALIGN- ANGLE b <sub>2</sub> DEG. +/-	APPROX. WEIGHT LBS.
SBG-3	SBG-3S		SBG-3SS	.1900	.5625	.281	.218	.025	.406	.293	2,750	6,480		4,400	11½	.02
SBG-4	SBG-4S		SBG-4SS	.2500	.6562	.343	.250	.025	.500	.364	4,200	10,000		6,700	13½	.02
SBG-5	SBG-5S		SBG-5SS	.3125	.7500	.375	.281	.025	.562	.419	5,800	13,900		9,200	12	.03
SBG-6	SBG-6S		SBG-6SS	.3750	.8125	.406	.312	.030	.656	.515	7,750	18,700		12,400	10	.04
SBG-7	SBG-7S		SBG-7SS	.4375	.9062	.437	.343	.035	.687	.530	9,300	22,300		14,900	9½	.05
SBG-8	SBG-8S	SBG-8SA	SBG-8SS	.5000	1.0000	.500	.390	.035	.781	.600	11,200	26,900	26,900	17,900	10	.07
SBG-10	SBG-10S	SBG-10SA	SBG-10SS	.6250	1.1875	.625	.500	.035	.968	.739	20,000	48,000	48,000	32,000	9	.12
SBG-12	SBG-12S	SBG-12SA	SBG-12SS	.7500	1.4375	.750	.593	.045	1.187	.920	30,000	78,000	78,000	48,000	9	.21
SBG-14	SBG-14S	SBG-14SA	SBG-14SS	.8750	1.5625	.875	.703	.045	1.312	.980	43,000	103,000	103,000	69,000	9½	.27
SBG-16	SBG-16S	SBG-16SA	SBG-16SS	1.0000	1.7500	1.000	.797	.045	1.500	1.118	52,000	125,000	125,000	83,000	9½	.38

The **SBG/SBG-S/SBG-SA/SBG-SS** family of metal-to-metal spherical bearings have common mounting dimensions and are manufactured in a variety of material combinations tailored for a wide range of applications. The bearings have lubrication grooves in the outer race and an interconnecting hole for grease lubrication. The outer races are chamfered on the O.D. to facilitate installation and retention into housings. Common applications include shock absorbers, industrial fans, packaging equipment, cylinders etc.

### MATERIAL SPECIFICATIONS

**SBG** - Bronze race for lower coefficient of friction - General purpose applications

OUTER RACE - Aluminum bronze

BALL - Alloy steel, heat treated, chrome plated

**SBG-S** - Heat treated race for higher load capacity and increased wear life

OUTER RACE - 4130 Alloy steel, heat treated, with protective plating for corrosion resistance

BALL - Alloy steel, heat treated, chrome plated

**SBG-SA** - Groove on ball I.D. and interconnecting hole to facilitate lubrication from the shaft to the bearing

OUTER RACE - 4130 Alloy steel, heat treated, with protective plating for corrosion resistance

BALL - Alloy steel, heat treated, chrome plated

**SBG-SS** - Stainless race and ball to improve corrosion resistance

OUTER RACE - 300 Series stainless steel

BALL - Stainless steel, heat treated

### NOTES:

1. Add letter "A" to suffix to indicate cross drilled oil hole in ball and race and a grooved I.D. on ball.
2. For design modifications, see page 173.
3. For mounting information, see Recommended Housing Bore Diameters page 172.

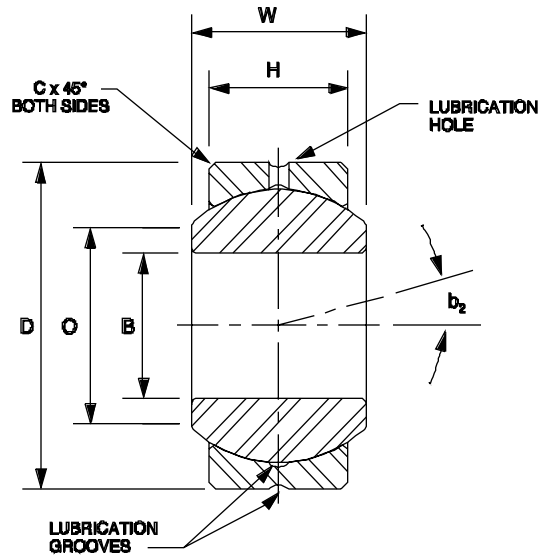

## COR Series Corrosion-Resistant Two-Piece Precision Spherical Bearings

PART NUMBER	BORE B +.0000 -.0005	OUTSIDE DIA. D +.0000 -.0005	BALL WIDTH W +.000 -.005	RACE WIDTH H +.005 -.005	CHAM- FER C REF.	BALL DIA. O REF.	BALL FLAT DIA. O REF.	MAX. STATIC RADIAL LOAD LBS.	MIS- ALIGN- MENT ANGLE b <sub>2</sub> DEG. +/-	APPROX. WEIGHT LBS.
COR-3	.1900	.5625	.281	.218	.025	.406	.293	4,800	11½	.02
COR-4	.2500	.6562	.343	.250	.025	.500	.364	7,500	13½	.02
COR-5	.3125	.7500	.375	.281	.025	.562	.419	10,400	12	.03
COR-6	.3750	.8125	.406	.312	.030	.656	.515	14,000	10	.04
COR-8	.5000	1.0000	.500	.390	.035	.781	.600	20,000	10	.07
COR-10	.6250	1.1875	.625	.500	.035	.968	.739	36,000	9	.12
COR-12	.7500	1.4375	.750	.593	.045	1.187	.920	54,000	9	.21
COR-14	.8750	1.5625	.875	.703	.045	1.312	.980	77,000	9½	.27
COR-16	1.0000	1.7500	1.000	.797	.045	1.500	1.118	93,500	9½	.38

The COR corrosion-resistant spherical bearing series is manufactured with a heat treated stainless steel race and ball for improved corrosion resistance and higher load capacity.

**MATERIAL SPECIFICATIONS**  
 OUTER RACE - Stainless steel, heat treated  
 BALL - Stainless steel, heat treated

### NOTES

1. For mounting information, see Recommended Housing Bore Diameters, page 172.

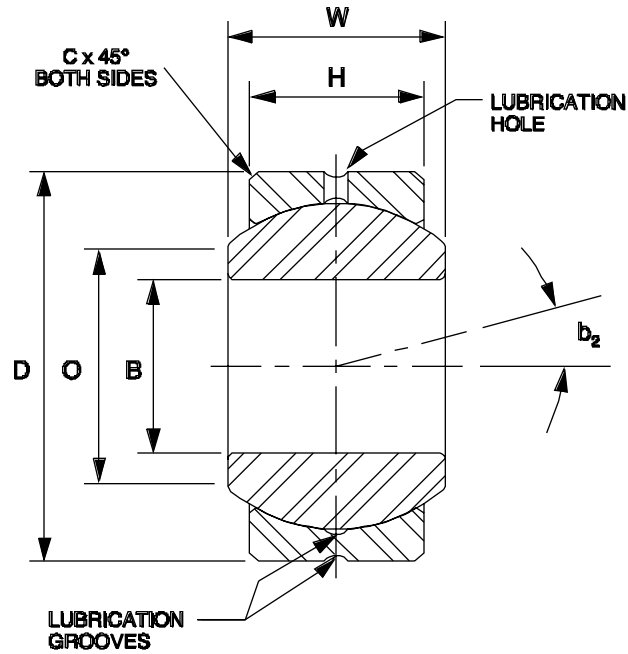

## COM Series Two-Piece Commercial Spherical Bearings

PART NUMBER	BORE B +.0015 -.0005	OUTSIDE DIA. D +.0000 -.0007	BALL WIDTH W +.005 -.005	RACE WIDTH H +.010 -.010	CHAMFER C REF.	BALL DIA. REF.	BALL FLAT DIA. O REF.	MAX. STATIC RADIAL LOAD LBS.	MIS- ALIGN- MENT ANGLE b <sub>2</sub> DEG. +/-	APPROX. WEIGHT LBS.
COM-3	.1900	.5625	.281	.218	.025	.406	.293	3,250	11 1/2	.02
COM-4	.2500	.6562	.343	.250	.025	.500	.364	4,900	13 1/2	.02
COM-5	.3125	.7500	.375	.281	.025	.562	.419	6,450	12	.03
COM-6	.3750	.8125	.406	.312	.030	.656	.515	8,250	10	.04
COM-7	.4375	.9062	.437	.343	.035	.687	.530	10,200	9 1/2	.05
COM-8	.5000	1.0000	.500	.390	.035	.781	.600	13,600	10	.07
COM-10	.6250	1.1875	.625	.500	.035	.968	.739	21,000	9	.12
COM-12	.7500	1.4375	.750	.593	.045	1.187	.920	30,000	9	.21
COM-14	.8750	1.5625	.875	.703	.045	1.312	.980	41,100	9 1/2	.27
COM-16	1.0000	1.7500	1.000	.797	.045	1.500	1.118	54,700	9 1/2	.38

COM commercial series spherical bearings are an economical alternative in a wide variety of industrial applications where a precision ball bore and close tolerances are not required.

### MATERIAL SPECIFICATIONS

**OUTER RACE - Carbon steel with protective coating for corrosion resistance**  
**BALL - Alloy steel, heat treated, chrome plated**

### NOTES

1. For design modifications, see page 173.
2. For mounting information, see Recommended Housing Bore Diameters, page 172.

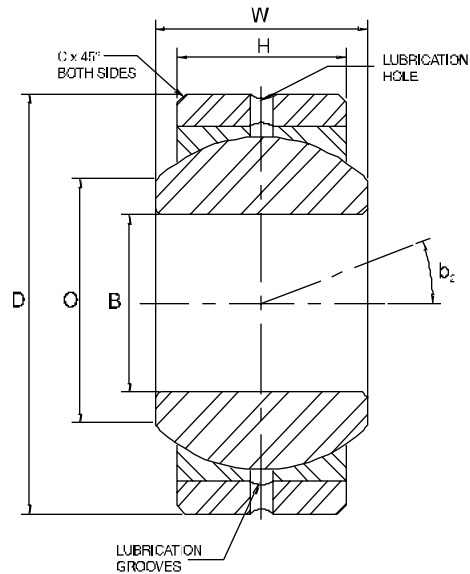

## FLBG Series Three-Piece Precision Spherical Bearings

PART NUMBER	BORE B +.0000 -.0005	OUTSIDE DIA. D +.0000 -.0005	BALL WIDTH W +.000 -.005	RACE WIDTH H +.000 -.005	CHAM- FER C REF.	BALL DIA. REF.	BALL FLAT DIA. O REF.	MAX. STATIC RADIAL LOAD LBS.	MIS- ALIGN- MENT ANGLE b <sub>2</sub> DEG. +/-	APPROX. WEIGHT LBS.
FLBG-3	.1900	.6250	.281	.187	.020	.406	.293	2,960	16½	.02
FLBG-4	.2500	.7500	.375	.281	.020	.500	.331	5,240	14½	.04
FLBG-5	.3125	.8750	.437	.313	.025	.625	.447	6,550	14½	.05
FLBG-6	.3750	1.0000	.500	.375	.025	.718	.517	8,600	12½	.08
FLBG-7	.4375	1.1875	.562	.437	.040	.812	.586	11,100	11	.12
FLBG-8	.5000	1.3125	.687	.531	.045	.937	.637	15,600	12½	.18
FLBG-10	.6250	1.5625	.875	.687	.045	1.187	.802	25,700	12	.33
FLBG-12	.7500	2.2500	1.250	.937	.050	1.625	1.038	47,600	15	.97
FLBG-16	1.0000	2.3750	1.125	.875	.065	1.750	1.345	48,200	10	.94

FLBG series spherical bearings are manufactured with a one-piece bronze race mounted in a carbon steel housing and contain a hardened steel chrome plated ball for improved spherical conformity and even load distribution. The FLBG has specialized mounting dimensions and will not interchange with other catalog spherical bearings with like bore sizes.

### MATERIAL SPECIFICATIONS

**OUTER MEMBER - Carbon steel with protective plating for corrosion resistance**

**RACE - Bronze**

**BALL - Alloy steel, heat treated, chrome plated**

### NOTES

1. For mounting information, see Recommended Housing Bore Diameters, page 172.



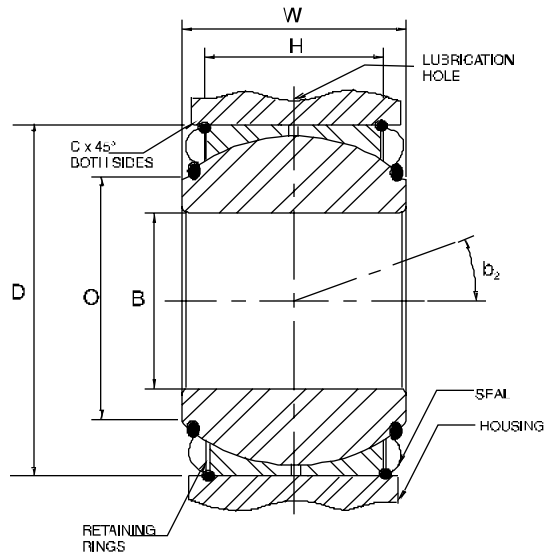

## BTS-LS Series Heavy Duty Sealed Two-Piece Precision Spherical Bearings

PART NUMBER	BORE B +.0000 -.0007	OUTSIDE DIA. D +.0000 -.0007	BALL WIDTH W +.000 -.005	RACE WIDTH H +.005 -.005	CHAMFER C REF.	BALL DIA. REF.	BALL FLAT DIA. O REF.	MAX. STATIC RADIAL LOAD LBS.	MISALIGNMENT ANGLE b <sub>2</sub> DEG. +/-	APPROX. WEIGHT LBS.
BTS-12LS	.7500	1.5000	1.250	.500	.015	1.250	1.000	31,500	13 1/2	.25
BTS-16LS	1.0000	2.2500	1.875	.875	.015	1.813	1.375	83,500	12	.95
BTS-20LS	1.2500	2.3750	1.875	.875	.015	2.000	1.625	94,000	9 1/2	.99
BTS-24LS	1.5000	2.7500	1.875	1.000	.015	2.375	2.000	130,000	7 1/2	1.44

PART NUMBER	HOUSING WIDTH (REF.)	GROOVE SPACING E +/- .002	RECOMMENDED SNAP RING	GROOVE DIA. Z	GROOVE WIDTH J
BTS-12LS	1.250	0.507	TRUARC #5000-150	1.576/1.584	.056/.060
			SPIROLOX #RR-150	1.551/1.556	.045/.048
BTS-16LS	1.687	0.882	TRUARC #5000-225	2.364/2.376	.086/.091
			SPIROLOX #RR-225	2.324/2.330	.055/.058
BTS-20LS	1.687	0.882	TRUARC #5000-237	2.499/2.511	.086/.091
			SPIROLOX #RR-237	2.453/2.459	.055/.058
BTS-24LS	1.875	1.007	TRUARC #5000-275	2.894/2.906	.103/.108
			SPIROLOX #RR-275	2.841/2.847	.055/.058

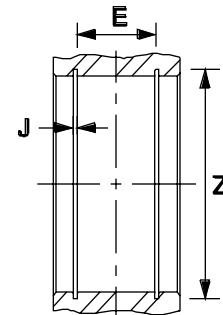

BTS-LS precision series *sealed* spherical bearings were developed for those difficult applications where bearings would be exposed to dust, dirt and grime. Two bellows type seals integral with each bearing help reduce contaminant entry as well as seal in lubricant.

### MATERIAL SPECIFICATION

**OUTER RACE - Carbon steel with protective plating for corrosion resistance**  
**BALL - Alloy steel, heat treated, chrome plated**  
**SEALS - Synthetic Rubber**

### NOTES

- Retaining rings are NOT furnished with the bearings.
- For mounting information, see Recommended Housing Bore Diameters, page 172.

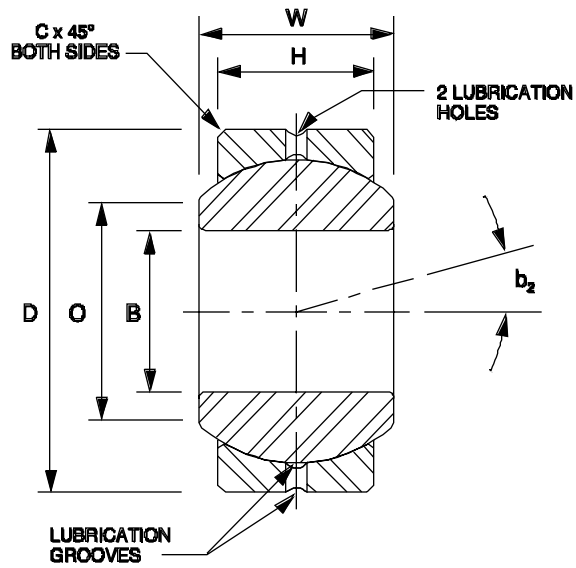

## BH-LS Series Heavy Duty Two-Piece Precision Spherical Bearings

PART NUMBER	BORE B +0.000 -0.007	OUTSIDE DIA. D +0.000 -0.007	BALL WIDTH W +0.000 -0.005	RACE WIDTH H +0.007 -0.007	CHAMFER C REF.	BALL DIA. REF.	BALL FLAT DIA. O REF.	MAX. STATIC RADIAL LOAD LBS.	MIS- ALIGN- MENT ANGLE b <sub>2</sub> DEG. +/-	APPROX. WEIGHT LBS.
BH-16LS	1.0000	2.0000	1.000	.781	.035	1.687	1.360	69,500	9	.55
BH-19LS	1.1875	2.3750	1.187	.937	.035	2.000	1.610	100,000	8½	.94
BH-20LS	1.2500	2.3750	1.187	.937	.035	2.000	1.610	100,000	8½	.90
BH-24LS	1.5000	2.7500	1.375	1.094	.035	2.312	1.860	135,000	8	1.36
BH-28LS	1.7500	3.1250	1.562	1.250	.040	2.625	2.110	178,000	8	1.95
BH-32LS	2.0000	3.5000	1.750	1.375	.040	2.937	2.360	221,000	8½	2.64

The BH-LS series is generally selected for use in heavier duty, higher load applications such as bearing connectors at the ends of hydraulic cylinders and mechanical shock arrestors, etc.

### MATERIAL SPECIFICATION

OUTER RACE - Carbon steel with protective plating for corrosion resistance

BALL - Alloy steel, heat treated, chrome plated

### NOTES

1. For mounting information, see Recommended Housing Bore Diameters, page 172.







## RECOMMENDED HOUSING BORE DIAMETERS – SPHERICAL BEARINGS

SPHERICAL BEARINGS		HOUSING BORE			
SERIES	BEARING O.D.	STEEL HOUSING		ALUMINUM HOUSING	
SBG, SBG-S, SBG-SS, SBG-SA	+ .0000/- .0005	MIN	MAX	MIN	MAX
3	.5625	.5616	.5620	.5614	.5619
4	.6562	.6553	.6557	.6551	.6556
5	.7500	.7491	.7495	.7489	.7494
6	.8125	.8116	.8120	.8114	.8119
7	.9062	.9053	.9057	.9051	.9056
8	1.0000	.9991	.9995	.9989	.9994
10	1.1875	1.1866	1.1870	1.1864	1.1869
12	1.4375	1.4366	1.4370	1.4364	1.4369
14	1.5625	1.5616	1.5620	1.5614	1.5619
16	1.7500	1.7491	1.7495	1.7489	1.7494
SERIES FLBG	+ .0000/- .0005	MIN	MAX	MIN	MAX
3	.6250	.6241	.6245	.6239	.6244
4	.7500	.7491	.7495	.7489	.7494
5	.8750	.8741	.8745	.8739	.8744
6	1.0000	.9991	.9995	.9989	.9994
7	1.1875	1.1865	1.1870	1.1863	1.1869
8	1.3125	1.3115	1.3120	1.3113	1.3119
10	1.5625	1.5613	1.5620	1.5611	1.5619
12	2.2500	2.2488	2.2495	2.2486	2.2494
16	2.3750	2.3738	2.3745	2.3736	2.3744
SERIES COM	+ .0000/- .0007	MIN	MAX	MIN	MAX
3	.5625	.5615	.5619	.5613	.5618
4	.6562	.6552	.6556	.6550	.6555
5	.7500	.7490	.7494	.7488	.7493
6	.8125	.8115	.8119	.8113	.8118
7	.9062	.9052	.9056	.9050	.9055
8	1.0000	.9990	.9994	.9988	.9993
10	1.1875	1.1864	1.1869	1.1862	1.1868
12	1.4375	1.4364	1.4369	1.4362	1.4368
14	1.5625	1.5614	1.5619	1.5612	1.5618
16	1.7500	1.7489	1.7494	1.7487	1.7493
SERIES COR	+ .0000/- .0005	MIN	MAX	MIN	MAX
3	.5625	.5616	.5620	.5614	.5619
4	.6562	.6553	.6557	.6551	.6556
5	.7500	.7491	.7495	.7489	.7494
6	.8125	.8116	.8120	.8114	.8119
8	1.0000	.9991	.9995	.9989	.9994
10	1.1875	1.1866	1.1870	1.1864	1.1869
12	1.4375	1.4366	1.4370	1.4364	1.4369
14	1.5625	1.5616	1.5620	1.5614	1.5619
16	1.7500	1.7491	1.7495	1.7489	1.7494
SERIES BTS-LS	+ .0000/- .0007	MIN	MAX	MIN	MAX
12	1.5000	1.4988	1.4993	1.4986	1.4992
16	2.2500	2.2488	2.2493	2.2486	2.2492
20	2.3750	2.3738	2.3743	2.3736	2.3742
24	2.7500	2.7488	2.7493	2.7486	2.7492
SERIES BH-LS	+ .0000/- .0007	MIN	MAX	MIN	MAX
16	2.0000	1.9988	1.9993	1.9986	1.9992
19	2.3750	2.3738	2.3743	2.3736	2.3742
20	2.3750	2.3738	2.3743	2.3736	2.3742
24	2.7500	2.7488	2.7493	2.7486	2.7492
28	3.1250	3.1238	3.1243	3.1236	3.1242
32	3.5000	3.4988	3.4993	3.4986	3.4992

# SEALMASTER® ROD ENDS & SPHERICAL BEARINGS

## DESIGN MODIFICATIONS

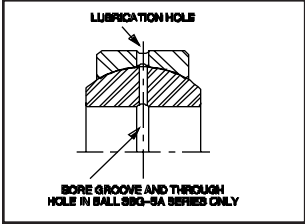
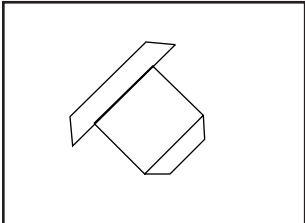
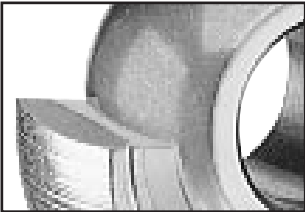
SEALMASTER rod ends and spherical bearings can be ordered with the following design modifications at extra cost

	DESIGN MODIFICATION	OPTION OFFERED ON THESE SERIES	ORDERING INSTRUCTIONS & EXAMPLE FOR SPECIFYING
<b>STOCK MODIFICATIONS</b>			
	Zerk Type Fitting	<b>AR, ARE, ARE-20 TR, TRE, TF, TM CFF, CFM</b>	Add "N" to part number suffix Example: a TRE-8 with a Zerk type fitting would be a TRE-8N (available on sizes 4 through 16 only)
	Y-Studs	<b>TR, TRE, TF, TM CFF, CFM CFF-T, CFM-T CTFD, CTMD</b>	Add "Y" to part number suffix Example: a TRE-8 with a stud would be a TRE-8Y (see page 164 for stud specifications).  Caution when selecting rod ends with Y-studs: Catalog load ratings are not applicable with Y-studs because of the reduced stud strength due to bending. For load ratings with Y-studs contact our engineering department.
<b>SPECIAL MODIFICATIONS</b>			
	Groove on Ball I.D. and Interconnecting Hole	<b>SBG, COM</b>	Add "A" to part number suffix Example: SBG-8A
	Flush Type Fitting	<b>AR, ARE, ARE-20 TR, TRE, TF, TM CFF, CFM</b>	Add "FN" to part number suffix Example: a TRE-8 with a flush type fitting would be a TRE-8FN (available on sizes 4 through 16 only)
	Alloy Steel Race	<b>AR, ARE, ARE-20 TR, TRE</b>	Add "S" to part number suffix Example: ARE-8S
	Stainless Steel Race	<b>AR, ARE, ARE-20 TR, TRE</b>	Add "SS" to part number suffix Example: TRE-6SS

# SEALMASTER<sup>®</sup> ROD ENDS & SPHERICAL BEARINGS

## APPLICATION INQUIRY WORKSHEET

\_\_\_\_\_  
Company Name

\_\_\_\_\_  
Address

\_\_\_\_\_

\_\_\_\_\_  
Contact

\_\_\_\_\_  
Phone

\_\_\_\_\_  
Fax

\_\_\_\_\_  
Date

### I. APPLICATION

Currently in use (if current application, what bearings are now being used?)  
\_\_\_\_\_

New \_\_\_\_\_

Manufacturer \_\_\_\_\_

Manufacturer's Part Number \_\_\_\_\_

Your Company's Part Number \_\_\_\_\_

Application Detail \_\_\_\_\_

### II. ENGINEERING DETAIL

Rod End                       2 pc                       Steel Race                       DELRIN Race

Spherical Bearing               3 pc                       Bronze Race                       TEFLON Liner

Misalignment Angle \_\_\_\_\_ (Degrees)

Radial Clearance \_\_\_\_\_ (Min/Max)

Axial Clearance \_\_\_\_\_ (Min/Max)

Preload Torque (lined rod ends only) \_\_\_\_\_ Min \_\_\_\_\_ Max

Materials:                      Ball \_\_\_\_\_                      Race \_\_\_\_\_                      Housing \_\_\_\_\_

Protective Finish:              Ball \_\_\_\_\_                      Race \_\_\_\_\_                      Housing \_\_\_\_\_

Solid Film                       Race ID                       Ball ID

Ball & Race ID                       Grease (Specify)

### III. OPERATING CONDITIONS

Radial \_\_\_\_\_ Lbs.                       Axial \_\_\_\_\_ Lbs.

Type:                       Reversing                       Alternating                       Unidirectional

Vibrating                       Static

Operating Temperature Range \_\_\_\_\_

Operating Speeds \_\_\_\_\_

Motion \_\_\_\_\_ (Degrees/Cycle)

Environmental Conditions               Dry                       Moisture                       Corrosive

Contamination

Bearing Life Required \_\_\_\_\_

**REMARKS – Specify bearing dimensions on reverse side – please attach part drawing or sketch if available**

Fax your application worksheet to:

**SEALMASTER ENGINEERING**  
Aurora, Illinois  
630-898-6064

\_\_\_\_\_  
Customer Signature

\_\_\_\_\_  
Date

# APPLICATION INQUIRY WORKSHEET

## FEMALE ROD END

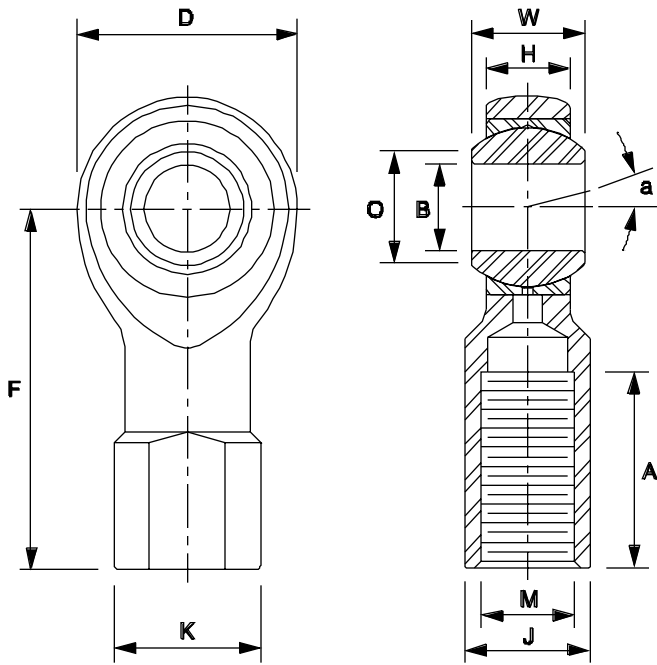

## MALE ROD END

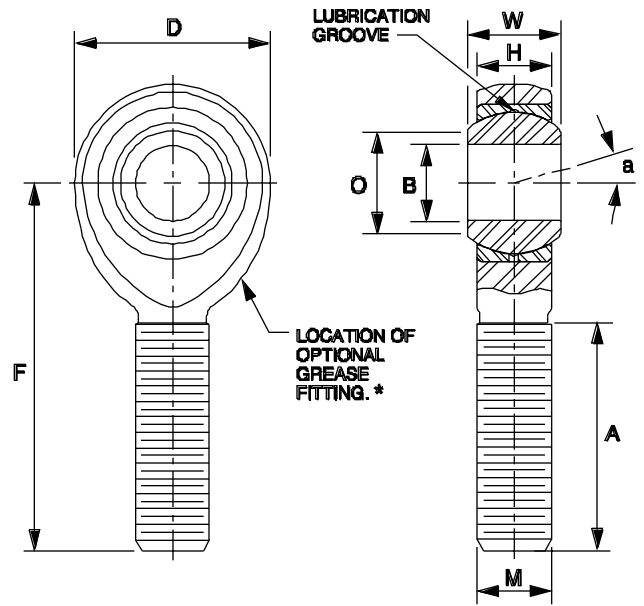

	BORE B	BALL WIDTH W	HOUSING WIDTH H	HEAD DIA. D	LENGTH TO CTR. OF BALL F	THREAD LENGTH A	THREAD SIZE M	BASE DIA. K	ACROSS WRENCH FLATS J	BALL DIA. O	BALL FLAT DIA. O	MIS- ALIGN- MENT ANGLE a
MALE												
FEMALE												

## SPHERICAL BEARING

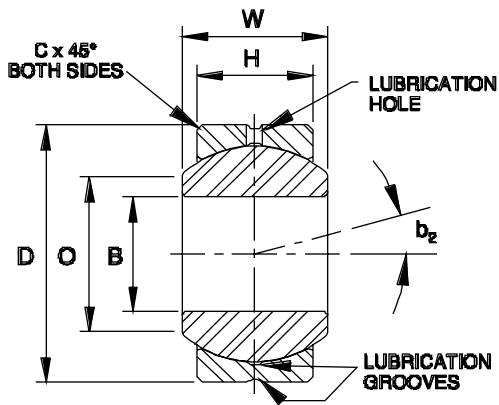

## SKETCH OR ADDITIONAL INFORMATION

BORE B	CHAMFER C REF	OUTSIDE DIA. D	BALL WIDTH W	RACE WIDTH H	BALL DIA. O	BALL FLAT DIA. O	MIS- ALIGN- MENT ANGLE $b_2$

# SEALMASTER®

## ENGINEERING...Technical Superiority

### BEARING SELECTION GUIDE

#### 1. Identify Application Parameters:

Shaft Speed in RPM: \_\_\_\_\_ Desired Operating Life in Hours: \_\_\_\_\_  
Bearing Loads in Lbs.: \_\_\_\_\_ Environments:  Wet  
Radial: \_\_\_\_\_  Chemical  
Thrust: \_\_\_\_\_  Dirty  Other  
Operating Temperature: \_\_\_\_\_  
 -30° to 200° F \*  
 200° to 400° F  
 -100° to -30° F \*

#### 2. Select Bearing Type and Bore:

Check Ball and Roller Bearing Ratings... *Pages 178-186.*

Selected Bore Size: \_\_\_\_\_  
Bearing Type:  
 Ball  
 Roller

#### 3. Select Housing Type... *Page 187.*

Housing Selected: \_\_\_\_\_

#### 4. Select Seal Design... *Pages 188-189.*

Seal Selected:  
 Felt Seal  Contact Seal  
 Other

#### 5. Select Lock Mechanism... *Pages 190-191.*

Shaft Lock Selected:  Single Lock Set Screw  
 Double Lock Set Screw  
 Skwezloc (Ball Bearings Only)

#### 6. Refer to ..... *Pages 10-13*

For **Ball Bearing** Nomenclature and Pictorial index to locate Dimensional Specifications.

Refer to ..... *Pages 96-97*

For **Roller Bearing** Nomenclature and Pictorial index to locate Dimensional Specifications.

Bearing Selected: \_\_\_\_\_

#### 7. For Application Parameters outside capabilities of selected components...

\*Contact Application Engineering (630-898-9620) or you can fax the Application Worksheet on Page 207 to (630-898-6064).

**For Ordering Information...** Contact Customer Service (800-354-9820)

# TABLE OF CONTENTS

<b>Ball Bearing Selection</b> .....	Pages 178-181
<b>Tapered Roller Bearing Selection</b> .....	Pages 182-183
<b>Sample Calculations</b> .....	Pages 184-186
<b>Housing Selection</b> .....	Pages 187
<b>Seal Selection</b> .....	Pages 188-189
<b>Lock Selection</b> .....	Pages 190-191

<b>Bearing Basics</b> .....	Pages 192-193
-----------------------------	---------------

## **Vibration Analysis...**

<b>Ball Bearings</b> .....	Page 194
<b>Roller Bearings</b> .....	Page 195

<b>Lubrication</b> .....	Page 196
--------------------------	----------

<b>Recommendations</b> .....	Page 197
<b>Fittings</b> .....	Page 198-199

## **Installation...**

<b>Shaft Mounting Procedures</b> .....	Page 200
<b>RPB Taper Roller Bearing Cartridge...</b>	
<b>Removal and Replacement</b> .....	Page 203
<b>Recommended Shaft Tolerances...</b>	
<b>Bore Tolerances</b> .....	Page 204
<b>High Speed- High Load Applications</b> .....	Page 204
<b>Set Screw and Capscrew Information</b> .....	Page 205

<b>ER, SC, and ERCI Housing Recommendations</b> .	Page 206
---	----------

<b>Application Worksheet</b> .....	Page 207
------------------------------------	----------

<i>Refer to Application Section</i> .....	Pages 128-143
to review a variety of Operational Conditions	



## Bearing Life Calculation

While both Ball and Roller bearings may be considered as possible designs on a given application, the formulas and calculations are different and will be treated separately. Typically, Ball bearings are usually specified on applications with lighter loads but have a higher speed capacity. As Ball bearings usually cost less for a given shaft size they are considered first. If the desired life or load capacity cannot be achieved with a ball bearing then a tapered roller bearing should be considered (see page 182 for Tapered Roller bearing life calculations).

### BEARING SYMBOLS FOR LIFE CALCULATION

- C - Basic Dynamic Rating (lbs)
- P - Equivalent Radial Load (lbs)
- L10 - Rated Life (Hours)
- $L_{na}$  - Adjusted Rated Life
- $F_a$  - Applied Thrust Load (lbs)
- $F_r$  - Applied Radial Load (lbs)
- $C_0$  - Static Rating (lbs)
- $n$  - Speed (RPM)
- K - Geometry Factor
- X - Radial Factor
- Y - Thrust Factor
- e - Geometry Ratio

## Ball Bearing Life Calculation

The following formula provided by the Anti Friction Bearing Manufacturers Association (ABMA) provide a method for calculating estimated fatigue life of Ball Bearings.

$$L_{10} = (C/P)^3 \times \frac{16667}{n}$$

Where:

**L10** = The number of hours that 90% of a group of identical bearings under ideal conditions will operate at a specific speed and load condition before fatigue failure is expected to occur.

**C** = The Basic Dynamic Load Rating in Lbs.

**P** = The equivalent Radial Load in Lbs.

**n** = Shaft speed in RPM.

Additionally, the ABMA provides application factors for Ball Bearings which need to be considered to determine an adjusted Rated Life ( $L_{na}$ ).

$$L_{na} = a_1 \times a_2 \times a_3 \times L_{10}$$

Where:

$L_{na}$  = Adjusted Rated Life.

$a_1$  = Reliability Factor.

Adjustment factor applied where estimated fatigue life is based on reliability other than 90% (See Table No 1).

**Table No. 1 Life Adjustment Factor for Reliability**

RELIABILITY %	$L_{na}$	$a_1$
90	L10	1
95	L5	0.62
96	L4	0.53
97	L3	0.44
98	L2	0.33
99	L1	0.21
50	L50	5

$a_2$  = Material Factor.

Life adjustment for Bearing race material. All Sealmaster Ball bearing races are manufactured from 52100 Vacuum Degassed Bearing steel. Therefore the  $a_2$  factor is 1.0 for all Sealmaster Ball Bearings. It is important to check with all manufacturers to ensure that proper adjustments are made when other bearing steels are used.

$a_3$  = Life Adjustment Factor for Operating Conditions.

This factor should take into account the adequacy of lubricant, presence of foreign matter, conditions causing changes in material properties, and unusual loading or mounting conditions. Assuming a properly selected bearing having adequate seals and lubricant operating below 250°F and tight fitted to the shaft, the  $a_3$  factor should be 1.0.

Mounted ball bearings are typically "slip fitted" to the shaft and rely on design features such as the inner race length and locking device for support. ABMA recommends an  $a_3$  factor of .456 for "slip fit" ball bearings.\*

Shock and Vibration\* — Vibration and shock loading can act as an additional loading to the steady expected applied load. When shock or vibration is present, the following  $a_3$ , Life Adjustment Factors are recommended. The shock factor is used in combination with the "slip fit" factor.

**Table No. 2 Shock/Vibration Factor**

Steady Loading	1.0
Light Shock/Vibration	.5
Moderate Shock/Vibration	.3

The  $a_3$  factor takes into account a wide range of application and mounting conditions as well as bearing features and design. Accurate determination of this factor is normally achieved through testing and in-field experience. Sealmaster offers a wide range of options which can maximize bearing performance. Consult Sealmaster Application Engineering for more information. \*See sample calculations on page 184.

## Selection

Select an initial bearing size and calculate the expected L10 life. If the life is not acceptable, select another bearing size as appropriate and recalculate the  $L_{na}$  life. Continue this iterative process until an appropriate  $L_{na}$  life is obtained.

## Combined Load Calculation

For applications where combined radial and thrust loads are present the equivalent radial load (P) must be calculated before applying the L10 life formula.

- For applications with only a radial load present  $P = F_r$   
Where  $F_r$  = Applied radial load in pounds.

- For applications with only a thrust load present  
Contact Sealmaster Application Engineering.

## Calculate (P) equivalent radial Load.

- Use Table 4 to identify the relative axial load factor ( $ND^2$ ).
- Determine the relative axial load (RAL):

$$RAL = \frac{F_a}{ND^2} \quad \begin{array}{l} \text{-applied thrust load} \\ \text{-relative axial load factor} \end{array}$$

- Match the nearest relative axial load value in Table #3 to the corresponding "e" value. For precise calculation, linearly interpolate the values for "e" for your exact relative axial load value.
- Calculate  $F_a/F_r$  and compare value to the "e" value found in step #3 above.
- Choose values for "X" and "Y" based on step #3 & 4 and from Table No. 3. Linear interpolation is recommended for exact calculations.
- Calculate equivalent radial load using the following equation:  
 $P = XF_r + YF_a$
- Calculate the adjusted life ( $L_{na}$ ) using the life calculation formula above.

**Refer to Page 182 for Relevant Disclaimer.**

### Explanation of Rating Selection:

- For standard and medium duty spherical outer race inserts as well as "AR" bearings, match the bearing insert number to the insert number on the ratings chart (i.e. 2-15, AR-2-15, 2-15D, and 2-15T all use 2-15 insert rating.)
- For "ER", "RB" and "TXP" inserts, match bearing insert number to "ER" number (i.e. ER-23 & TXP 23 both use an ER-23 insert rating.)

Contact SEALMASTER Engineering for additional details.

### Ball Bearing Selection - New Applications:

Using variations of the life formulas and application information, it is possible to select bearings based on desired life, load applied, and shaft speed. **This method can be applied where axial load is less than or equal to 1/2 the radial load.**

- Determine required application hours ( $L_{na}$ ).
- Calculate  $L_{10}$  using adjustment factors:

$$L_{10} = \frac{L_{na}}{a_1 \times a_2 \times a_3}$$

- Calculate Basic Dynamic Radial Rating ( $C_{req}$ ).

$$C_{req} = P \times \left( \frac{L_{10} \times N}{16,667} \right)^{1/3}$$

- Use Table No. 4, find a basic Dynamic Radial Rating Value greater than or equal to  $C_{req}$  calculated in step # 3.
- Select any bearing from the row in step # 4 or larger. If  $C_{req}$  is greater than the largest Basic Dynamic Radial Rating Value of Table No. 4, go to Roller Bearing Selection on page 182.
- If Ball bearing is selected, proceed with housing, seal, lock selection pages 187-191.

Typical operating temperature range for standard bearings is -20° to 200° F. For operating temperatures outside this range contact application engineering. For Maximum speed information, see tables on pages 180 and 181.

**Table No. 3**

### Equivalent Load Calculation Data - Ball Bearings

Relative Axial Load	e	Fa/Fr ≤ e		Fa/Fr > e	
		x	y	x	y
		1 0		0.56	
24.92	0.19				2.30
50.03	0.22				1.99
99.91	0.26				1.71
149.35	0.28				1.55
200.10	0.30				1.45
300.15	0.34				1.31
500.25	0.38				1.15
749.65	0.42				1.04
999.05	0.44				1.00

**Table No. 4 Load Ratings - Ball Bearings**

STANDARD DUTY			MEDIUM DUTY		BASIC DYNAMIC RADIAL RATING	STATIC RADIAL RATING	RELATIVE AXIAL LOAD FACTOR ND <sup>2</sup>	THRUST RATING
SHAFT SIZE	INSERT #	ER #	SHAFT SIZE	INSERT #				
1/2	2-08	ER/RB-8			2611	1444	0.7056	741
9/16	2-09	ER-9						
5/8	2-010	ER/RB-10						
11/16	2-011	ER-11						
3/4	2-012	ER/RB-12						
20mm	5204	ER/RB-204						
13/16	2-013				2801	1651	0.7840	490
7/8	2-014	ER/RB-14						
15/16	2-015	ER/RB-15						
25mm	5205	ER/RB-205						
1	2-1	ER/RB-16						
1 1/16	2-11	ER/RB-17	15/16	3-015	4381	2567	1.2996	1177
1 1/8	2-12	ER/RB-18	25mm	5305				
30mm	5206	ER/RB-206	1	3-1				
1 3/16	2-13	ER/RB-19						
1 1/4	1-14	RB-20R						
1 1/4	2-14	ER-20	30mm	5306	5782	3493	1.7424	1709
1 5/16	2-15	ER-21	1 3/16	3-13				
1 3/8	2-16	ER-22						
35mm	5207	ER-207						
1 7/16	2-17	ER-23						
1 1/2	2-18	ER-24	35mm	5307	7340	4467	2.2500	2254
1 9/16	2-19	ER-25	1 7/16	3-17				
40mm	5208	ER-208						
1 5/8	2-110	ER-26	1 1/2	3-18	7901	5139	2.5000	2350
1 11/16	2-111	ER-27	40mm	5308				
1 3/4	2-112	ER-28						
45mm	5209	ER-209						
1 13/16	2-113		1 11/16	3-111	7889	5216	2.5000	2350
1 7/8	2-114	ER-30	1 3/4	3-112				
1 15/16	2-115	ER-31	45mm	5309				
50mm	5210	ER-210						
2	1-2							
2	2-2	ER-32	1 15/16	3-115	9752	6601	3.3160	2886
2 1/8	2-22	ER-34	50mm	5310				
55mm	5211	ER-211						
2 3/16	2-23	ER-35						
2 1/4	2-24	ER-36	55mm	5311	11789	8150	3.9690	4105
2 5/16	2-25		2 3/16	3-23				
60mm	5212	ER-212						
2 3/8	2-26	ER-38						
2 7/16	2-27	ER-39						
2 1/2		ER-40	2 7/16	3-27	13971	10063	4.7610	4503
2 11/16	2-211	ER-43	2 1/2	3-28				
70mm	5214	ER-214	65mm	5313				
2 7/8	2-214	ER-46	2 11/16	3-211				
2 15/16	2-215	ER-47	70mm	5314	14839	11224	5.2371	5207
75mm	5215	ER-215						
3		ER-48	2 15/16	3.215				
80mm	5216	ER-216	75mm	5315	17412	13174	6.1875	6032
3 3/16	2-33	ER-51	3	3-3				
3 1/4	2-34	ER-52	80mm	5316				
3 3/8	2-36	ER-54	3 3/16	3-33				
3 7/16	2-37	ER-55						
3 1/2	2-38		3 7/16	3-37	21566	16301	7.7440	7839
90mm	5218							
3 15/16		ER-63	100mm	5320	29905	23553	11.2360	11097
4		ER-64	3 15/16	3-315				
			4	3-4	37482	33267	15.6250	16697
			4 7/16	3-47				
			4 15/16	3-415				

# BALL BEARING RATING TABLES



## GOLDLINE BALL BEARING RATING TABLES

This chart displays the Goldline Ball Bearing load capacities for a given L10 life, speed, and shaft size. The shaded area indicates the maximum speed ratings for Skwezloc® and double lock bearings (applicable on sizes available). All speeds listed are for the standard felt seal. See Seal Selection for alternate seals, pages 188-189.

Values in the table represent loads at ideal conditions with press fit mounting to the shaft. ABMA recommends de-rating of slip fit mounted bearings. To obtain de-rated load, divide the load in the table by 1.3. Values in the table represent equivalent radial loads only. For combined load determination, see page 178. Areas designated by "-" exceed maximum value for standard bearings. Consult Sealmaster Application Engineering for load and speed applications not covered in this table.

Double Lock and Skwezloc use same bearing insert ratings as single lock inserts shown below.

For RB, TX, and ETX inserts use standard duty load ratings for the appropriate shaft size.

**Table No. 5 Load Ratings - Ball Bearings**

STANDARD DUTY			MEDIUM DUTY		REVOLUTIONS PER MINUTE																
SHAFT SIZE	INSERT #	ER #	SHAFT SIZE	INSERT #	L10 HOURS	50	150	500	1000	1750	2000	2500	3500	4500	5000	5500	6000	6500	7500	8000	10000
1/2	2-08	ER-8			5000	619	619	491	390	324	310	287	257	236	228	221	215	209	199	195	181
9/16	2-09	ER-9			10000	583	583	390	310	257	246	228	204	188	181	175	170	166	158	154	143
5/8	2-010	ER-10			30000	583	404	270	215	178	170	158	141	130	126	122	118	115	109	107	100
11/16	2-011	ER-11			50000	491	341	228	181	150	144	133	119	110	106	103	100	97	92	90	84
3/4	2-012	ER-12			100000	390	270	181	144	119	114	106	95	87	84	81	79	77	73	71	67
20mm	5204	ER-204																			
13/16	2-013				5000	664	664	527	418	347	332	308	276	253	245	237	230	224	213	213	-
7/8	2-014	ER-14			10000	625	625	418	332	276	264	245	219	201	194	188	183	177	169	169	-
15/16	2-015	ER-15			30000	625	433	290	230	191	183	170	152	139	135	130	127	123	117	117	-
25mm	5205	ER-205			50000	527	366	245	194	161	154	143	128	118	114	110	107	104	99	99	-
1	2-1	ER-16			100000	418	290	194	154	128	122	114	102	93	90	87	85	82	78	78	-
1 1/16	2-11	ER-17	15/16	3-015	5000	1039	1039	825	654	543	519	482	431	396	383	370	360	351	334	334	-
1 1/8	2-12	ER-18	1	3-1	10000	978	978	654	519	431	412	383	342	315	304	294	286	278	265	265	-
1 3/16	2-13	ER-19	25mm	5305	30000	978	678	454	360	299	286	265	237	218	211	204	198	193	184	184	-
30mm	5206	ER-206			50000	825	572	383	304	252	241	224	200	184	178	172	167	163	155	155	-
1 1/4R	1-14				100000	654	454	304	241	200	191	178	159	146	141	136	133	129	123	123	-
1 1/4	2-14	ER-20	30mm	5306	5000	1290	1290	1088	864	717	686	636	569	523	505	489	475	463	-	-	-
1 5/16	2-15	ER-21	1 3/16	3-13	10000	1290	1290	864	686	569	544	505	452	415	401	388	377	367	-	-	-
1 3/8	2-16	ER-22			30000	1290	895	599	475	394	377	350	313	288	278	269	262	255	-	-	-
35mm	5207	ER-207			50000	1088	755	505	401	333	318	295	264	243	234	227	221	215	-	-	-
1 7/16	2-17	ER-23			100000	864	599	401	318	264	253	234	210	193	186	180	175	171	-	-	-
1 1/2	2-18	ER-24	1 7/16	3-17	5000	1638	1638	1381	1096	910	870	808	722	664	641	621	603	-	-	-	-
1 9/16	2-19	ER-25	35mm	5307	10000	1638	1638	1096	870	722	691	641	573	527	509	493	479	-	-	-	-
40mm	5208	ER-208			30000	1638	1136	760	603	501	479	445	397	365	353	342	332	-	-	-	-
					50000	1381	958	641	509	422	404	375	335	308	298	288	280	-	-	-	-
					100000	1096	760	509	404	335	321	298	266	245	236	229	222	-	-	-	-
1 5/8	2-110	ER-26	1 1/2	3-18	5000	1763	1763	1487	1180	979	937	870	777	715	690	669	-	-	-	-	-
1 11/16	2-111	ER-27	45mm	5308	10000	1763	1763	1180	937	777	744	690	617	567	548	531	-	-	-	-	-
1 3/4	2-112	ER-28			30000	1763	1222	818	650	539	516	479	428	393	380	368	-	-	-	-	-
45mm	5209	ER-209			50000	1487	1031	690	548	455	435	404	361	332	320	310	-	-	-	-	-
					100000	1180	818	548	435	361	345	320	286	263	254	246	-	-	-	-	-
1 13/16	2-113		1 11/16	3-111	5000	1760	1760	1485	1178	978	935	868	776	714	689	-	-	-	-	-	-
1 7/8	2-114	ER-30	1 3/4	3-112	10000	1760	1760	1178	935	776	742	689	616	567	547	-	-	-	-	-	-
1 15/16	2-115	ER-31	45mm	5309	30000	1760	1221	817	649	538	515	478	427	393	379	-	-	-	-	-	-
50mm	5210	ER-210			50000	1485	1029	689	547	454	434	403	360	331	320	-	-	-	-	-	-
	1-2				100000	1178	817	547	434	360	345	320	286	263	254	-	-	-	-	-	-
2	2-2	ER-32	1 15/16	3-115	5000	2176	2176	1835	1457	1209	1156	1073	1010	959	-	-	-	-	-	-	-
2 1/8	2-22	ER-34	50mm	5310	10000	2176	2176	1457	1156	959	918	852	802	762	-	-	-	-	-	-	-
55mm	5211	ER-211			30000	2176	1509	1010	802	665	636	591	556	528	-	-	-	-	-	-	-
2 3/16	2-23	ER-35			50000	1835	1273	852	676	561	537	498	469	445	-	-	-	-	-	-	-
					100000	1457	1010	676	537	445	426	395	372	353	-	-	-	-	-	-	-

Notes:

- For high load-high speed applications, see engineering section, page 204.
- Typical operating temperature range for standard bearings is -20° to 200° F. For operating temperatures outside this range contact application engineering.

### GOLDLINE BALL BEARING RATING TABLES

This chart displays the Goldline Ball Bearing load capacities for a given L10 life, speed, and shaft size. The shaded area indicates the maximum speed ratings for Skwezloc® and double lock bearings (applicable on sizes available). All speeds listed are for the standard felt seal. See Seal Selection for alternate seals, pages 188-189.

Values in the table represent loads at ideal conditions with press fit mounting to the shaft. ABMA recommends de-rating of slip fit mounted bearings. To obtain de-rated load, divide the load in the table by 1.3. Values in the table represent equivalent radial loads only. For combined load determination, see page 178. Areas designated by "-" exceed maximum value for standard bearings. Consult Sealmaster Application Engineering for load and speed applications not covered in this table.

Double Lock and Skwezloc use same bearing insert ratings as single lock inserts shown below. For RB, TX, and ETX inserts use standard duty load ratings for the appropriate shaft size.

**Table No. 5 (Continued) Load Ratings - Ball Bearings**

STANDARD DUTY			MEDIUM DUTY		REVOLUTIONS PER MINUTE																			
SHAFT SIZE	INSERT #	ER #	SHAFT SIZE	INSERT #	L10 HOURS	50	150	250	500	750	1000	1250	1500	1750	2000	2500	3000	3500	4000	4500				
2 1/4	2-24	ER-36	55mm	5311	5000	2631	2631	2631	2219	1938	1761	1635	1538	1461	1398	1298	1221	1160	1109	1030	969	921	881	-
2 5/16	2-25		2 3/16	3-23	10000	2631	2631	2219	1761	1538	1398	1298	1221	1160	1109	1030	969	921	881	-	-	-	-	-
60mm	5212	ER-212			30000	2631	1824	1538	1221	1067	969	900	847	804	769	714	672	638	611	-	-	-	-	-
2 3/8	2-26	ER-38			50000	2219	1538	1298	1030	900	817	759	714	678	649	602	567	538	515	-	-	-	-	-
2 7/16	2-27	ER-39			100000	1761	1221	1030	817	714	649	602	567	538	515	478	450	427	409	-	-	-	-	-
2 1/2		ER-40	2 7/16	3-27	5000	3118	3118	3118	2629	2297	2087	1937	1823	1732	1656	1538	1447	1375	1315	1220	1149	1091	-	-
2 11/16	2-211	ER-43	2 1/2	3-28	10000	3118	3118	2629	2087	1823	1656	1538	1447	1375	1315	1220	1149	1091	-	-	-	-	-	-
70mm	5214	ER-214	65mm	5313	30000	3118	2162	1823	1447	1264	1149	1066	1003	953	912	846	796	756	-	-	-	-	-	-
					50000	2629	1823	1538	1220	1066	969	899	846	804	769	714	672	638	-	-	-	-	-	-
					100000	2087	1447	1220	969	846	769	714	672	638	610	567	533	506	-	-	-	-	-	-
2 7/8	2-214	ER-46	2	3-211	5000	3311	3311	3311	2793	2440	2217	2058	1936	1839	1759	1633	1537	1460	1396	1296	1220	1159	-	-
2 15/16	2-215	ER-47	11/16	5314	10000	3311	3311	2793	2217	1936	1759	1633	1537	1460	1396	1296	1220	1159	-	-	-	-	-	-
75mm	5215	ER-215	70mm		30000	3311	2296	1936	1537	1343	1220	1132	1066	1012	968	899	846	803	-	-	-	-	-	-
					50000	2793	1936	1633	1296	1132	1029	955	899	854	817	758	713	678	648	-	-	-	-	-
					100000	2217	1537	1296	1029	899	817	758	713	678	648	602	566	538	-	-	-	-	-	-
3		ER-48	2	3-215	5000	3885	3885	3885	3277	2863	2601	2415	2272	2158	2064	1916	1803	-	-	-	-	-	-	-
80mm	5216	ER-216	15/16	5315	10000	3885	3885	3277	2601	2272	2064	1916	1803	1713	1639	1521	1431	-	-	-	-	-	-	-
3 3/16	2-33	ER-51	75mm	3-3	30000	3885	2694	2272	1803	1575	1431	1329	1250	1188	1136	1055	992	-	-	-	-	-	-	-
			3		50000	3277	2272	1916	1521	1329	1207	1121	1055	1002	985	890	837	-	-	-	-	-	-	-
					100000	2601	1803	1521	1207	1055	958	890	837	795	761	706	664	-	-	-	-	-	-	-
3 1/4	2-34	ER-52	80mm	5316	5000	3975	3975	3975	3516	3071	2791	2591	2438	2316	2215	2056	1935	-	-	-	-	-	-	-
3 3/8	2-36	ER-54	3 3/16	3-33	10000	3975	3975	3516	2791	2438	2215	2056	1935	1838	1758	1632	1536	-	-	-	-	-	-	-
3 7/16	2-37	ER-55			30000	3975	2890	2438	1935	1690	1536	1426	1342	1274	1219	1132	1065	-	-	-	-	-	-	-
					50000	3516	2438	2056	1632	1426	1295	1202	1132	1075	1028	954	898	-	-	-	-	-	-	-
					100000	2791	1935	1632	1295	1132	1028	954	898	853	816	757	713	-	-	-	-	-	-	-
3 1/2	2-38		3 7/16	3-37	5000	4812	4812	4812	4059	3546	3222	2991	2814	2673	2557	2374	-	-	-	-	-	-	-	-
90mm	5218	-			10000	4812	4812	4059	3222	2814	2557	2374	2234	2122	2029	1884	-	-	-	-	-	-	-	-
					30000	4812	3337	2814	2334	1951	1773	1646	1549	1471	1407	1306	-	-	-	-	-	-	-	-
					50000	4059	2814	2374	1884	1646	1495	1388	1306	1241	1187	1102	-	-	-	-	-	-	-	-
					100000	3222	2234	1884	1495	1306	1187	1102	1037	985	942	874	-	-	-	-	-	-	-	-
3 15/16		ER-63	100mm	5320	5000	6673	6673	6673	5628	4917	4467	4147	3902	3707	3546	-	-	-	-	-	-	-	-	-
4	-	ER-64	3 15/16	3-315	10000	6673	6673	5628	4467	3902	3546	3291	3097	2942	2814	-	-	-	-	-	-	-	-	-
			4	3-4	30000	6673	4627	3902	3097	2706	2458	2282	2148	2040	1951	-	-	-	-	-	-	-	-	-
					50000	5628	3902	3291	2612	2282	2074	1925	1811	1721	1646	-	-	-	-	-	-	-	-	-
					100000	4467	3097	2612	2074	1811	1646	1528	1438	1366	1306	-	-	-	-	-	-	-	-	-
-	-	-	4 7/16	3-47	5000	7975	7975	7975	7054	6163	5599	5198	4891	4646	4444	-	-	-	-	-	-	-	-	-
			4	3-415	10000	7975	7975	7054	5599	4891	4444	4125	3882	3688	3527	-	-	-	-	-	-	-	-	-
			15/16		30000	7975	5799	4891	3882	3391	3081	2860	2692	2557	2446	-	-	-	-	-	-	-	-	-
					50000	7054	4891	4125	3274	2860	2599	2413	2270	2157	2063	-	-	-	-	-	-	-	-	-
					100000	5599	3882	3274	2599	2270	2063	1915	1802	1712	1637	-	-	-	-	-	-	-	-	-

Notes:

- For high load-high speed applications, see engineering section, page 204.
- Typical operating temperature range for standard bearings is -20° to 200° F. For operating temperatures outside this range contact application engineering.

# ROLLER BEARING RATING & SELECTION **SEALMASTER®**

This section outlines the formula used to select bearing size or calculate expected bearing life for RPB type Tapered Roller Bearings.

Tapered Roller Bearings are excellent for applications where radial and/or thrust load ratings exceed the capabilities of a Ball Bearing. *Note: Maximum speeds are lower for Tapered Roller Bearings than Ball Bearings.*

## Roller Bearing Life Calculation

**L10** = The number of hours that 90% of a group of identical bearings under ideal conditions will operate at a specific speed and load condition before fatigue failure is expected to occur.

**C** = The Basic Dynamic Load Rating in Lbs. (2 Row)

**P** = The equivalent Radial Load in Lbs.

**n** = Shaft speed in RPM.

$$L10 = (C/P)^3 \times \frac{3000 \text{ hours} \times 500 \text{ RPM}}{n}$$

## LIFE CALCULATIONS

Select an initial bearing size, and calculate the expected L10 life. If the life is not acceptable, select another bearing size as appropriate and recalculate the L10. Continue this iterative process until an appropriate L10 life is obtained.

## Combined Load Calculation

For applications where combined radial and thrust loads are present the equivalent radial load (P) must be calculated before applying the L10 life formula.

For applications with only a radial load present  $P = F_r$   
Where  $F_r$  = Applied radial load in pounds.

For applications with only a thrust load present,  
Consult Sealmaster Application Engineering.

## Calculate (P) equivalent radial Load.

1. Calculate the bearing internal thrust reaction (FIR):

$$FIR = \frac{0.6 \times F_r}{K} \text{ -applied radial load}$$

-factor K in Tabel No. 6

2. If the thrust load ( $F_a$ ) is less than or equal to FIR, then calculate the equivalent radial load as follows:

$$P = (0.5 \times F_r) + (0.83 \times K \times F_a)$$

3. If the thrust load ( $F_a$ ) is greater than FIR then calculate the equivalent radial load as follows:

$$P = (0.4 \times F_r) + (K \times F_a)$$

4. Calculate the expected L10 life using the single row basic dynamic load rating:

$$L10 = \left( \frac{\text{single row load rating}}{P} \right)^{10/3} \times \frac{3000 \times 500}{n}$$

**Table No. 6 Load Ratings - Roller Bearings**

SHAFT SIZE (INCHES)	RADIAL RATING (POUNDS)		(1) THRUST RATING (POUNDS)	FACTOR K	ALLOWABLE THRUST ON PILLOW BLOCK HOUSING	
	2 ROW	1 ROW			2 BOLT BASE	4 BOLT BASE
1 3/16 - 1 1/4	2975	1710	1390	1.23	960	-
1 3/8 - 1 7/16	4760	2740	2080	1.31	1600	-
1 1/2 - 1 11/16	6140	3530	2600	1.36	1580	-
1 3/4 - 2	8070	4640	2540	1.83	2500	-
2 3/16	8570	4910	2980	1.65	2360	-
2 1/4 - 2 1/2	9030	5220	3470	1.51	2350	5700
2 11/16 - 3	9630	5510	4260	1.30	3340	5700
3 3/16 - 3 1/2	15320	8790	7410	1.19	4450	10980
3 15/16 - 4	20980	12100	9800	1.23	-	7250
4 7/16 - 4 1/2	25750	14800	13100	1.13	-	6680
4 15/16 - 5	35520	20400	16000	1.27	-	9000

(1) For thrust load pillow block applications, the bearing thrust rating must be compared to the allowable thrust load capacity of the housing. In a number of sizes, the allowable thrust capacity of the pillow block housing is less than the thrust rating of the bearing. When this circumstance exists, do not exceed the pillow block housing thrust capacity.

In thrust applications utilizing flange or piloted flange housings, please contact Sealmaster engineering for allowable housing thrust limits.

**NOTE:** EPT believes that the information provided above is true and accurate. However, individual applications may vary. Thus, the information provided above cannot be relied upon as complete. The customer assumes all risk from the use thereof, and EPT assumes no responsibility for any use of the foregoing information by its customers.

### TAPERED ROLLER BEARING RATING TABLES

This chart displays the Sealmaster RPB Roller Bearing load capacities for a given L10 life, speed, and shaft size. For combined load determination see Page 182. Areas designated by “-” exceed maximum value for standard bearings. Consult Sealmaster Application Engineering for load and speed applications not covered in this table.

**Table No. 7 Load Ratings - Tapered Roller Bearings**

SHAFT SIZE	L10 HOURS	REVOLUTIONS PER MINUTE														
		50	100	250	500	750	1000	1250	1500	1750	2000	2500	3000	3500	4000	
1 3/16	5000	3360	3360	3142	2552	2260	2073	1939	1836	1753	1684	1575	1491	1424	1368	
	10000	3360	3360	2552	2073	1836	1684	1575	1491	1424	1368	1279	1211	1156	1111	
	30000	2975	2416	1836	1491	1320	1211	1279	1072	1024	984	920	871	832	902	
	50000	2552	2073	1575	1279	1133	1039	1081	920	878	844	789	747	714	763	
1 1/4	100000	2073	1684	1279	1039	920	844	971	747	714	685	641	607	580	685	
	1 3/8	5000	5376	5376	5028	4084	3616	3317	3104	2937	2804	2694	2520	2386	2278	2278
		10000	5376	5376	4084	3317	2937	2694	2521	2386	2278	2188	2047	1938	1850	-
		30000	4760	3866	2937	2386	2112	1938	2048	1716	1638	1574	1472	1394	1331	-
50000		4084	3317	2520	2047	1812	1662	1732	1472	1406	1350	1263	1196	1142	-	
1 7/16	100000	3317	2694	2047	1662	1472	1350	1555	1196	1142	1097	1026	971	927	-	
	1 1/2	5000	6934	6934	6485	5268	4664	4279	4000	3789	3617	3475	3250	3077	-	-
		10000	6934	6934	5268	4279	3789	3475	3249	3077	2938	2823	2640	2500	-	-
		30000	6140	4987	3789	3077	2725	2500	2640	2213	2113	2030	1899	1798	-	-
50000		5268	4279	3250	2640	2338	2144	2231	1899	1813	1742	1629	1542	-	-	
1 5/8	100000	4279	3475	2640	2144	1899	1742	2007	1542	1473	1415	1323	1253	-	-	
	1 11/16	5000	9114	9114	8524	6923	6130	5624	5259	4979	4754	4568	4272	-	-	-
		10000	9114	9114	6923	5624	4979	4568	4271	4045	3862	3710	3470	-	-	-
		30000	8070	6555	4979	4045	3581	3285	3470	2909	2777	2668	2496	-	-	-
50000		6923	5624	4272	3470	3072	2818	2934	2496	2383	2289	2141	-	-	-	
1 3/4	100000	5624	4568	3470	2818	2496	2289	2636	2027	1935	1859	1739	-	-	-	
	2	5000	9679	9679	9052	7352	6510	5972	5584	5288	5049	4851	4537	-	-	-
		10000	9679	9679	7352	5972	5288	4851	4587	4295	4101	3940	3685	-	-	-
		30000	8570	6961	5288	4295	3803	3489	3684	3089	2950	2834	2650	-	-	-
50000		7352	5972	4538	3585	3263	2993	3115	2650	2530	2431	2274	-	-	-	
2 3/16	100000	5972	4851	3685	2993	2650	2431	2799	2153	2055	1975	1847	-	-	-	
	2 1/4	5000	10198	10198	9538	7747	6860	6293	5940	5572	5320	5111	-	-	-	-
		10000	10198	10198	7747	6293	5572	5111	4824	4526	4321	4152	-	-	-	-
		30000	9030	7335	5572	4526	4007	3676	3918	3255	3108	2986	-	-	-	-
50000		7747	6293	4780	3883	3438	3154	3313	2793	2666	2562	-	-	-	-	
2 7/16	100000	6293	5111	3883	3154	2793	2562	2977	2268	2166	2081	-	-	-	-	
	2 1/2	5000	10876	10876	10171	8262	7316	6711	6279	5942	5674	-	-	-	-	-
		10000	10876	10876	8262	6711	5942	5451	5100	4826	4608	-	-	-	-	-
		30000	9630	7822	5942	4826	4274	3920	4143	3471	3314	-	-	-	-	-
50000		8262	6711	5098	4141	3666	3363	3502	2978	2843	-	-	-	-	-	
2 11/16	100000	6711	5451	4141	3363	2978	2732	3147	2419	2310	-	-	-	-	-	
	2 3/4	5000	17302	17302	16181	13143	11638	10676	9983	9453	-	-	-	-	-	-
		10000	17302	17302	13143	10676	9453	8671	8109	7678	-	-	-	-	-	-
		30000	15320	12444	9453	7678	6799	6237	6587	5522	-	-	-	-	-	-
50000		13143	10676	8110	6587	5833	5351	5569	4738	-	-	-	-	-	-	
3 1/2	100000	10676	8671	6587	5351	4738	4346	5004	3848	-	-	-	-	-	-	
	3 3/16	5000	23694	23694	22159	17999	15938	14620	13673	-	-	-	-	-	-	-
		10000	23694	23694	17999	14620	12945	11875	11106	-	-	-	-	-	-	-
		30000	20980	17041	12945	10515	9311	8541	9021	-	-	-	-	-	-	-
50000		17999	14620	11106	9021	7988	7327	7627	-	-	-	-	-	-	-	
3 7/16	100000	14620	11875	9021	7327	6488	5952	6852	-	-	-	-	-	-	-	
	4	5000	29081	29081	27198	22091	19561	17944	16783	-	-	-	-	-	-	-
		10000	29081	29081	22091	17944	15889	14575	13632	-	-	-	-	-	-	-
		30000	25750	20915	15889	12906	11427	10483	10072	-	-	-	-	-	-	-
50000		22091	17944	13631	11072	9804	8993	9362	-	-	-	-	-	-	-	
4 1/2	100000	17944	14575	11072	8993	7963	7305	8412	-	-	-	-	-	-	-	
	4 15/16	5000	40114	40114	37517	30473	26983	24752	-	-	-	-	-	-	-	-
		10000	40114	40114	30473	24752	21917	20105	-	-	-	-	-	-	-	-
		30000	35520	28851	21917	17802	15763	14460	-	-	-	-	-	-	-	-
50000		30473	24752	18803	15273	13524	12405	-	-	-	-	-	-	-	-	
100000	24752	20105	15273	12405	10985	10076	-	-	-	-	-	-	-	-		

1. For high load-high speed applications, see page 204.  
 2. Typical operating temperature range for standard bearings is -20° to 200° F. For operating temperatures outside this range contact application engineering.

## SAMPLE CALCULATIONS

### APPLICATION EXAMPLES:

#### EXAMPLE # 1 Pure Radial Load

##### Question # 1:

What is the adjusted bearing life ( $L_{na}$  hours) for an NP-39 Sealmaster Ball Bearing with no shock conditions and the following application criteria?

Design Load (P)	=	1300 lbs.
Speed (n)	=	1000 RPM
Shaft Size	=	2 7/16 Inches
Operating Temperature	=	125°F

##### Solution:

1. Begin with the  $L_{10}$  life formula:  $L_{10} = (C/P)^3 \times \frac{16667}{n}$

Look up the insert of an NP-39 on page 20. From Table No. 4 on page 179, the Basic Dynamic Radial Rating is 11,789 lbs.

$$L_{10} = \left( \frac{11789}{1300} \right)^3 \times \frac{16667}{1000} = 12,430 \text{ hours}$$

2. Apply the life adjustment factors:

$$\begin{aligned} L_{na} \text{ hours} &= L_{10} \times a_1 \times a_2 \times a_3 \\ L_{na} \text{ hours} &= 12,430 \times 1 \times 1 \times 0.456 \\ L_{na} \text{ hours} &= 5,700 \text{ hours} \end{aligned}$$

##### Question # 2:

What is the adjusted bearing life ( $L_{10}$  hours) for an NP-39 Sealmaster Ball Bearing with moderate shock conditions and the same application criteria from above?

##### Solution:

1. From Table # 2 on page 178:  $a_3 = 0.5 \times 0.456$ .
2. Re-Apply the life adjustment factors to the previously calculated  $L_{10}$  life:

$$\begin{aligned} L_{na} \text{ hours} &= L_{10} \times a_1 \times a_2 \times a_3 \\ L_{na} \text{ hours} &= 12,430 \times 1 \times 1 \times (0.5 \times 0.456) \\ L_{na} \text{ hours} &= 2,830 \text{ hours} \end{aligned}$$

##### Question # 3:

What is the bearing life ( $L_{10}$  hours) for an RPB-207-2 Tapered Roller Bearing with no shock conditions and the same application criteria from above?

##### Solution:

1. Begin with the  $L_{10}$  life formula:  $L_{10} = (C/P)^{10/3} \times \frac{500 \times 3,000}{n}$
2. RPB-207 has 2 7/16" shaft size. From Table No. 6 on page 182, the Radial Rating is 9,030 lbs.

$$L_{10} = \left( \frac{9030}{1300} \right)^{10/3} \times \frac{500 \times 3,000}{1000} = 959,000 \text{ hrs.}$$

##### Question # 4:

What is the bearing life ( $L_{10}$  hours) for an RPB-207-2 Tapered Roller Bearing with moderate shock conditions and the same application criteria from above?

##### Solution:

1. From Table No. 2 on page 178:

$$L_{10} = 0.5 \times \left( \frac{9030}{1300} \right)^{10/3} \times \frac{500 \times 3,000}{1000} = 479,500 \text{ hrs.}$$

Refer to page 182 for relevant disclaimer.

#### EXAMPLE # 2 Combined Radial and Thrust Load

##### Question # 1:

What is the adjusted bearing life ( $L_{na}$  hours) for an NP-39 Sealmaster Ball Bearing with no shock conditions and the following application criteria?

Design Radial Load ( $F_r$ )	=	500 lbs.
Design Thrust Load ( $F_a$ )	=	1000 lbs.
Speed (n)	=	1000 RPM
Shaft Size	=	2 7/16 Inches
Operating Temperature	=	125°F

##### Solution:

1. Calculate  $F_a/F_r = 1000/500 = 2$
2. Begin by calculating the Relative Axial Load (RAL):  
(From Table No. 4, page 17

$$RAL = \frac{F_a}{ND^2} = \frac{1000}{3.9690} = 251 \text{ lbs.}$$

3. From Table No. 3 on page 179, interpolate RAL between 200.10 and 300.15 and "e" between 0.30 and 0.34 to obtain an "e" value:

$$\frac{251 - 200.10}{300.15 - 200.10} = \frac{e - 0.30}{0.34 - 0.30} \quad \text{Therefore } e = .32$$

4. From Table No. 3 on page 179, determine the value of "X" and "Y" through interpolation. Interpolate "e" between 0.30 and 0.34 and "Y" between 1.45 and 1.31 because  $F_a/F_r > e$ ;

$$\frac{0.32 - 0.30}{0.34 - 0.30} = \frac{Y - 1.45}{1.31 - 1.45}$$

$$\text{Therefore } Y = 1.38$$

$$X = .56$$

5. Determine the equivalent radial load (P):

$$\begin{aligned} P &= (X F_r) + (Y F_a) \\ &= (0.56 \times 500) + (1.38 \times 1000) = 1660 \text{ lbs.} \end{aligned}$$

$$L_{10} = (C/P)^3 \times \frac{16667}{n}$$

Look up the insert of an NP-39 on page 30. From Table No. 4 on page 179, the Basic Dynamic Radial Rating is 11,789 lbs.

$$L_{NA} = .456 \times \left( \frac{11789}{1660} \right)^3 \times \frac{16667}{1000} = 2720 \text{ hours}$$

##### Question # 2:

What is the bearing life ( $L_{10}$  hours) for an RPB-207-2 Tapered Roller Bearing with no shock conditions and the same application criteria from above?

##### Solution:

1. Find the K factor value from Table No. 6 on page 182,  $K = 1.51$ .
2. Calculate the internal thrust reaction (FIR):

$$FIR = \frac{0.6 \times F_r}{K} \text{ -applied radial load}$$

-factor K in Tabel No. 6

$$FIR = \frac{0.6 \times 500}{1.51} = 199 \text{ lbs.}$$

3. Since the thrust load is greater than the internal thrust reaction (FIR) use the following formula from page 182 to calculate the equivalent radial load.

$$\begin{aligned} P &= (0.4 \times F_r) + (K \times F_a) \\ P &= (0.4 \times 500) + (1.51 \times 1000) = 1710 \text{ lbs.} \end{aligned}$$

4. Calculate the expected  $L_{10}$  life using the single row rating. Single row rating = 5,220 lbs. This is found in Table No. 6 on page 182.

$$L_{10} = \left( \frac{\text{single row load rating}}{P} \right)^{10/3} \times \frac{500 \times 3000}{n}$$

$$L_{10} = \left( \frac{5220}{1710} \right)^{10/3} \times \frac{3000 \times 500}{1000} = 61,900 \text{ hrs.}$$

### COMPUTING BEARING LOADS:

In the computation of bearing loads in any application of a Sealmaster unit, the principal factor determining the selection of the unit is the equivalent radial load to which the bearing will be subjected. These radial loads result from any one or any combination of the following sources:

1. Weights of machine parts supported by bearings.
2. Tension due to belt or chain pull.
3. Centrifugal force from out of balance, eccentric or cam action.

The resulting load from any one, or any combination of the above sources is further determined by knowing:

1. The magnitude of the load.
2. Direction of the load.
3. The point of load application.
4. The distance between bearing centers.

Bearing loads are the result of force acting on the shaft. Direction, magnitude, and location with respect to the bearings must be considered when calculating bearing loads. The following cases are typical examples of loads encountered and methods of calculating bearing loads.

**CASE # 1**  
**Straddle Mount Fan, Cantilever Drive**

Load on Bearing A =  $\frac{(P_1 \times b) - (P_2 \times c)}{k}$

$$= \frac{(1,000 \times 4) - (150 \times 3)}{11} = 323 \text{ lbs.}$$

Load on Bearing B =  $\frac{(P_1 \times a) + (c + k) \times (P_2)}{k}$

$$= \frac{(1,000 \times 7) + (3 + 11) \times (150)}{11}$$

$$= 827 \text{ lbs.}$$

**CASE # 3**  
**Straddle, Cantilever Fan, Cantilever Drive**

Load on Bearing A =  $\frac{P_1 \times (k + a) + (P_2 \times c) - (P_3 \times d)}{k}$

$$= \frac{60 \times (12 + 2) + (180 \times 6) - (70 \times 4)}{12}$$

$$= 137 \text{ lbs.}$$

Load on Bearing B =  $\frac{-(P_1 \times a) + (P_2 \times b) + P_3 \times (k + d)}{k}$

$$= \frac{-(60 \times 2) + (180 \times 6) + 70 \times (12 + 4)}{12}$$

$$= 173 \text{ lbs.}$$

**CASE # 2**  
**Cantilever Fan and Drive**

Load on Bearing A =  $\frac{P_1 \times (a + k) - (P_2 \times b)}{k}$

$$= \frac{200 \times (4 + 9) - (80 \times 2)}{9} = 271 \text{ lbs.}$$

Load on Bearing B =  $\frac{P_2 \times (k + b) - (P_1 \times a)}{k}$

$$= \frac{80 \times (9 + 2) - (200 \times 4)}{9}$$

$$= 9 \text{ lbs.}$$

**CASE # 4**  
**Drive Load Calculation**

$P = \frac{126,000 \times \text{HP}}{\text{RPM} \times d} \times K = \frac{126,000 \times 5}{2,400 \times 10} \times 1.5 = 39.4 \text{ lbs.}$

HP = horsepower  
RPM = revolutions per minute  
d = pitch diameter of pulley in inches  
K = constant for type of drive used  
K = 1.5 for V-belts  
K = 2 to 3 for flat transmission belts  
K = 1.1 for chain drives

Apply P to Case 1, 2 or 3 if applicable



**CASE # 5  
Vibrating Drives**

Load due to Centrifugal and Inertial Forces - In a shaker or gyrating screen bearing application, the load on the bearings is increased by sudden stopping, starting, and reversing of typically large loads. This can be expressed as a basic physical law:

$$\text{Force} = \text{Mass} \times \text{Acceleration}$$

In order to use this law we develop from it the following equation:

$$F = .000341 \times WR(\text{RPM})^2$$

where: F = load or force in lbs.  
 W = weight of rotating mass in lbs.  
 R = radius of rotation or throw in feet  
 RPM = shaft rotation in revolutions per minute

What is the centrifugal bearing load on a shaker screen which weighs 2,500 lbs., has a throw of 1/4 in. and whose shaft speed is 500 RPM?

$$F = .000341 \times 2,500 \times \frac{250}{12} \times (500)^2 = 4,440 \text{ lbs.}$$

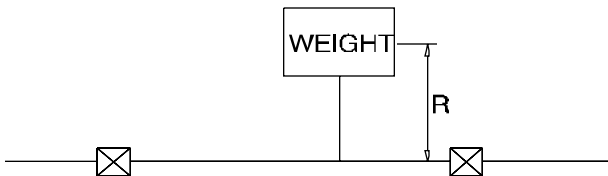

**CASE # 6  
Variable Load Application**

When bearings are used on applications with a variable load and a variable number of hours each day the equivalent radial load must be calculated.

For example a bearing supporting a flat belt idler roll sees the following loads throughout the day:

- 75 lb. radial load - 90% of a 24 hour day
- 575 lb. radial load - 9% of a 24 hour day
- 742 lb. radial load - 1% of a 24 hour day
- Speed = 750 RPM

A five year bearing life is required with approximately 7,200 operating hours per year. This means that the L10 life will be 5 x 7,200 or 36,000 hours.

A formula for variable loading can be written for equivalent load as follows:

$$P^3N = P_1^3N_1 + P_2^3N_2 + P_3^3N_3$$

In which:

P = equivalent load in lbs. the bearing must support.

N = hours of operation.

This load formula does not necessarily limit the calculation to three varying loads, but is a form of progression, which can have any number of variable loads and hours. The first load of 75 lbs., imposed for 90% of a 24 hour day, becomes P<sub>1</sub> and 90% of total required life of 36,000 hours or 32,400 hours is the value of N<sub>1</sub>. Value for P<sub>2</sub>, P<sub>3</sub>, N<sub>2</sub> and N<sub>3</sub> are derived in similar fashion. Place these values in the formula as follows:

$$(P^3 \times 36,000) = (75^3 \times 32,400) + (575^3 \times 3,240) + (742^3 \times 360)$$

Thus: P = 278.4 lbs.

Using the Ball Bearing selection formula on page 179, calculate the required dynamic radial rating (Creq):

$$Creq = P \times \left( \frac{L10 \times RPM}{16,667 \times .456} \right)^{1/3} = 278.4 \times \left( \frac{36,000 \times 750}{16,667 \times .456} \right)^{1/3}$$

Creq = 42472 pounds.

From Table No. 4 on page 179, the closest *Basic Dynamic Radial Rating* value greater than Creq is 4381 pounds. The bore sizes listed in that row, 1 1/16" to 1 1/4" will be satisfactory for this application. Actual L10 hours can be calculated by plugging the actual *Basic Dynamic Radial Rating (4381 lbs)* into the L10 formula.

$$L10 = (C/P)^3 \times \frac{16,667}{n}$$

$$L10 = \left( \frac{4381}{278.4} \right)^3 \times \frac{16,667}{750} = 86,598 \text{ hrs.}$$

Refer to page 182 for relevant disclaimer.

### GOLD LINE BALL BEARING PILLOW BLOCKS



Pillow blocks are the most popular housing style for mounted ball bearings and are available with two or four bolt mounting holes.

- One piece housing design.
- The most popular housing design is the NP Series.
- A variety of configurations are available to fit specific dimensional requirements to interchange with competitive units.
- Gray cast iron, Class 25.
- Alternate materials available on request: Malleable, Ductile Iron, Cast Steel.
- Self-Aligning to  $\pm 2^\circ$

### GOLD LINE RPB SELF-ALIGNING TAPERED ROLLER BEARING PILLOW BLOCKS



Pillow blocks are the most popular housing style for mounted tapered roller bearings and are available as two piece-split housings with two or four bolt mounting holes. Split housings allow easy cartridge replacement without having to disturb the bearings housing position.

- Two piece-split housing design.
- The most popular housing design is the RPB Series pillow blocks.
- RPB interchanges with Type E tapered roller bearings.
- Self-Aligning to  $\pm 3^\circ$ .
- Gray cast iron, Class 25
- Alternate materials available on request: Malleable, Ductile Iron, Cast Steel (SPB Series).

### FLANGES (BALL AND ROLLER BEARINGS)



Flange units are the second most popular housing style for mounted bearings. Two-bolt, three-bolt, and four-bolt housing styles are available. Flange blocks are strongest when the load is applied toward the base (thrust). They are often used for vertical shaft mount.

### HANGER BEARINGS (BALL BEARINGS)



These units are uniquely configured to be threaded onto the end of a pipe. They typically hang down to support a screw conveyor shaft or as linkage ends. There are two series:

**SCHB** (Screw Conveyor) units have a lubrication fitting inside the threaded shank for remote lubrication by extending a grease line through the pipe.

**SEHB** (Eccentric Drive) units have grease fittings on the external body of the unit as shown in picture above. SEHB units are frequently ordered with the BDZ suffix (i.e. SEHB-16 BDZ) for tight internal clearances and housing fits for better performance in high vibration.

### CARTRIDGE INSERTS (BALL AND ROLLER BEARINGS)



Cartridge inserts are cylindrical OD bearing units designed to be mounted in a cylindrical ID housing supplied by the user. Sealmaster Ball Bearing Cartridge inserts: ER, SC, MSC. Sealmaster RPB Series Tapered Roller Bearing Cartridge inserts: ERCL.

### TAKE-UPS (BALL BEARINGS)

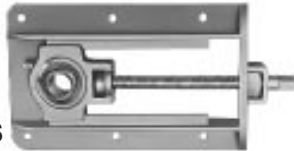

Take-up units are designed for take-up frames to provide adjustment capability of bearing position. These are commonly used on belt conveyors to adjust belt tension. Sealmaster ST Ball Bearing units have slotted sides that fit into STH Take-up frame rails. The acme threaded adjustment rod are self-cleaning and positions the bearing.

### FLANGE CARTRIDGES (BALL AND ROLLER BEARINGS)



Flange cartridges are made in four-bolt and six-bolt housing styles. They are strongest when the load is applied in a radial direction and can withstand rotating radial loads in eccentric load situations.

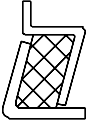
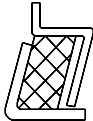
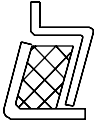

Table No. 8

HOUSING TYPE COMPARISON					
STYLE	RADIAL	THRUST**	SPACE LIMITATION	LOAD DIRECTION CHANGE	MATERIAL
Pillow Block	✓✓✓✓	✓✓	✓✓	✓	CAST IRON
Tapped Base	✓✓✓✓	✓✓	✓✓✓✓	✓	CAST IRON
4 Bolt Flange	✓✓✓	✓✓✓	✓✓✓	✓✓	CAST IRON
2 Bolt Flange	✓✓	✓✓	✓✓✓✓	✓	CAST IRON
Flange Cartridge	✓✓✓✓	✓✓✓✓	✓✓✓	✓✓✓✓	CAST IRON
Flange Bracket	✓✓	✓✓	✓✓✓✓	✓	CAST IRON
Hangar	✓✓	✓	N/A	✓	DUCTILE IRON
Take-Up	✓✓	✓	N/A	✓	CAST IRON
Cartridge Insert	✓✓✓✓	*	✓✓✓✓	*	*

Legend: Excellent 3 3 3 3, Good 3 3 3, Fair 3 3, Poor 3

w Depends on mounting configuration

ww Consult Sealmaster Application Engineering for Housing Thrust Capacity.

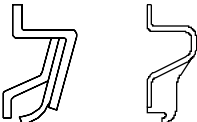
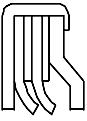
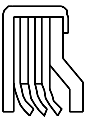
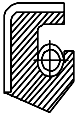
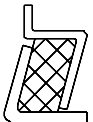
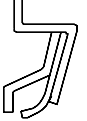
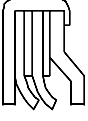
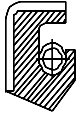
<p><b>STANDARD FELT</b> Ball and Roller</p>  <p>A standard feature on all Sealmaster mounted bearings. This seal consists of (2) metal stampings and a felt washer sealing element. Recommend for use in dry applications. Select contact seals for wet applications.</p>	<p><b>BACKED OFF</b> Ball</p>  <p>This is similar to the standard felt seal except there is a special gap between the flinger and the felt. Reduced drag is an advantage. This seal typically has some increased grease purge and reduced sealing.</p>	<p><b>WEB SEAL</b> (Backed Off/Cut Down) Ball</p>  <p>The web seal is the same as the backed off seal with a reduced outside diameter on the felt to reduce seal drag while maintaining adequate sealing protection in web applications.</p>	<p><b>X-SEAL</b> Ball</p>  <p>The X-Seal is the same as the standard felt seal but with no felt. Sealing is accomplished with two metal shields which form a labyrinth to keep out dry contaminants. Used in applications requiring extremely low drag operation.</p>
<p><b>CONTACT SEAL</b> Ball and Roller</p>  <p>Contact Ball or Tapered Roller seals can be specified by adding a "C" onto the part description of a bearing unit. Recommend for use in wet applications.</p>	<p><b>PROGARD</b> (Double Lip Contact) Ball</p>  <p>The Progard seal has two heavy metal stampings that hold two Buna N coated over fabric washers. Provides additional protection from high pressure washes and harsh environments.</p>	<p><b>SAFEGARD</b> (Triple Lip Contact) Ball</p>  <p>Similar to the ProGard seal, but with three *Buna N washers for added protection from high pressure washes or harsh contamination. * Also called Nitrile</p>	<p><b>ULTRAGARD</b> (Spring Loaded Buna N) Ball</p>  <p>This V-shaped rubber seal is molded into a metal stamping. A spring is retained in the body of the "V" and provides constant pressure to keep the seal tight against the inner race.</p>
<p><b>NOMEX®</b> (High Temp Felt) Ball and Roller</p>  <p>Similar to the felt design. The felt washer is replaced by a woven Dupont® Nomex material. Dupont and Nomex are registered trademarks of the Dupont Co.</p>	<p><b>HEATGARD</b> (High Temp Contact) Ball</p>  <p>Similar to the contact seal. The Buna N/Fabric washer is replaced by a fiberglass coated with silicone washer.</p>	<p><b>HEATGARD PLUS</b> (High Temp Double Contact) Ball</p>  <p>A combination of ProGard and the HeatGard, this double lip seal provides additional protection from contaminants in a very rugged seal.</p>	<p><b>HEATGARD ULTRA</b> (High Temp Spring) Ball</p>  <p>A high temp version of the UltraGard using a special elastomer which provides an excellent combination of sealing and temperature resistance.</p>

**Note: Other modifications are required for High Temperature Applications. See pages 130-131.**

**Table No. 9 SEAL SELECTION COMPARISONS** (See page 189 for maximum speeds and availability by shaft size).

TYPE	MATERIAL	STANDARD (STD) MADE TO ORDER (MTO)	HIGH SPEED	WATER RESISTANT	RESIST DRY CONTAMINANT	REDUCED DRAG	MAX. TEMP. °F
Felt	Standard	Felt	STD	✓✓✓✓	Not Rec.	✓✓✓	250°F
	Backed Off	Felt	MTO	✓✓✓✓	Not Rec.	✓✓✓	250°F
	Web Seal	Felt	MTO	✓✓✓✓	Not Rec.	✓✓✓✓	250°F
Contact	Contact	*Buna N coated Dacron	STD	✓✓✓	✓✓	✓✓✓	250°F
	ProGard	*Buna N coated Dacron	MTO	✓✓	✓✓✓	Not Rec.	250°F
	SafeGard	*Buna N coated Dacron	MTO	✓	✓✓✓✓	Not Rec.	250°F
	UltraGard	*Buna N	MTO	✓✓✓	✓✓✓✓	✓	250°F
Nomex	-	Nomex	MTO	✓✓✓✓	Not Rec.	✓✓✓	400°F
Silicon Fiberglass	HeatGard	Silicon Fiberglass	MTO	✓	✓✓✓	Not Rec.	400°F
	HeatGard Plus	Silicon Fiberglass	MTO	✓	✓✓✓	Not Rec.	400°F
	HeatGard Ultra	FKM	MTO	✓✓✓	✓✓✓✓	✓	400°F
X-Seal	-	-	MTO	✓✓✓✓	Not Rec.	✓	400°F

Legend: Excellent 3 3 3 3, Good 3 3 3, Fair 3 3, Poor 3

\* Also called Nitrile.

### BALL BEARING SEAL SPEED TABLES

This chart displays maximum speed rating for various ball bearing seals and locking devices. Values in the table represent speeds at ideal conditions. Other application factors may reduce the speed rating of a bearing. The blue color numbers indicate ideal maximum speeds using a double lock system or a Skwezloc system. Mounting methods become important when running near the maximum speeds. See the Installation Section. Check the insert pages for Skwezloc and Double Lock availability.

### TAPERED ROLLER BEARING MAXIMUM INNER SPEEDS

Roller Bearing maximum speeds are not limited by seals. See Tapered Roller Bearing Rating tables on page 183 for maximum speeds for felt, contact and nomex seal.

Table No. 10

STANDARD DUTY			MEDIUM DUTY		MAX SEAL SPEED REVOLUTIONS PER MINUTE							
Shaft Size	Insert#	ER#	Shaft Size	Insert #	Standard Felt Backed off Felt (Web) Cut Down Backed off Felt Nomex	Contact Seal	ProGard	SafeGard	HeatGard	HeatGard +	UltraGard	HeatGard Ultra
1/2	2-08	ER-8	-	-								
9/16	2-09	ER-9	-	-								
5/8	2-010	ER-10	-	-	7300							
11/16	2-011	ER-11	-	-		6450	1600	N/A	1600	N/A	6450	N/A
3/4	2-012	ER-12	-	-	10200							
20mm	5204	ER-204	-	-								
13/16	2-013	-	-	-								
7/8	2-014	ER-14	-	-	6350							
15/16	2-015	ER-15	-	-		6350	N/A	550	1400	N/A	2500	2500
25mm	5205	ER-205	-	-	9000							
1	2-1	ER-16	-	-								
1 1/16	2-11	ER-17	15/16	3-015								
1 1/8	2-12	ER-18	1	3-1	5450							
1 3/16	2-13	ER-19	25mm	5305		5450	N/A	500	1050	500	2200	2200
30mm	5206	ER-206	-	-	7600							
1 1/4	2-14	ER-20	30mm	5306								
1 5/16	2-15	ER-21	1 3/16	3-13	4650							
1 3/8	2-16	ER-22	-	-		4650	N/A	450	1000	450	2000	2000
35mm	5207	ER-207	-	-	6500							
1 7/16	2-17	ER-23	-	-								
1 1/2	2-18	ER-24	1 1/2	3-18	4150							
1 9/16	2-19	ER-25	40mm	5308		4150	N/A	400	925	400	N/A	1900
40mm	5208	ER-208	-	-	5850							
1 5/8	2-110	ER-26	1	3-111	3800							
1 11/16	2-111	ER-27	11/16	3-112		3800	N/A	350	850	350	N/A	1000
1 3/4	2-112	ER-28	1 3/4	5309								
45mm	5209	ER-209	45mm	-	5300							
1 13/16	2-113	-	1	3-111								
1 7/8	2-114	ER-30	11/16	3-112	3550							
1 15/16	2-115	ER-31	1 3/4	5309		3550	N/A	325	775	325	N/A	N/A
50mm	5210	ER-210	45mm	-	5000							
1-2	-	-	-	-								
2	2-2	ER-32	1	3-115	3250							
2 1/8	2-22	ER-34	15/16	5310		3250	700	300	700	300	N/A	N/A
55mm	5211	ER-211	50mm	-	4500							
2 3/16	2-23	ER-35	-	-								
2 1/4	2-24	ER-36	55mm	5311								
2 5/16	2-25	ER-212	2 3/16	3-23	3000							
60mm	5212	ER-38	-	-		2550	650	N/A	650	250	N/A	N/A
2 3/8	2-26	ER-39	-	-	4100							
2 7/16	2-27	-	-	-								
2 1/2	-	-	2 7/16	3-27	2500							
2 11/16	2-211	ER-40	2 1/2	3-28		2225	550	N/A	550	225	N/A	N/A
70mm	5214	ER-43	65mm	5313	3600							
2 7/8	2-214	ER-46	2 11/16	3-211	2450							
2 15/16	2-215	ER-47	70mm	5314		2100	525	N/A	525	200	N/A	N/A
75mm	5215	ER-215	-	-	3400							
3	-	-	2 15/16	3-215	2250							
80mm	5216	ER-48	75mm	5315		1950	500	N/A	500	N/A	N/A	N/A
3 3/16	2-33	ER-51	3	3-3	3150							
3 1/4	2-34	ER-52	80mm	5316	2125							
3 3/8	2-36	ER-54	3 3/16	3-33		1850	450	N/A	450	N/A	N/A	N/A
3 7/16	2-37	ER-55	-	-	3000							
3 1/2	2-38	-	3 7/16	3-37	2000							
90mm	5218	-	-	-	2800		1725	425	425	N/A	N/A	N/A
3 15/16	-	ER-63	100mm	5320	1700							
4	-	ER-64	3 15/16	3-315		1450	375	N/A	375	N/A	N/A	N/A
-	-	-	4	3-4	2400							
-	-	-	4 7/16	3-47	1375							
-	-	-	4 15/16	3-415	1950		N/A	N/A	N/A	N/A	N/A	N/A

\* If seal max speed in this chart exceeds bearing max speed from rating tables or speed that is deemed acceptable for the application, lowest applicable speed applies.

### “SLIP FIT” MOUNTING

Sealmaster Mounted Ball and RPB Series Tapered Roller Bearings are designed to slip fit onto the shaft. Slip fit means that the shaft is usually slightly smaller, and the inner ring bore is slightly larger than the nominal shaft sizes listed in the bearing tables. Slip fit mounting is very popular and economical as it does not require specialized equipment or tooling to mount the bearing on the shaft. Reliability of the lock is still dependent on the proper mounting techniques and proper shaft size control.

### SHAFT LOCKING SYSTEM SELECTION

Selection of the shaft locking system may be dependent on some or all of the following application criteria:

- Lock reliability.
- Shaft run-out.
- Vibrating systems.
- Vibration reduction (isolation devices).
- Shaft fretting.
- Distress on the shaft surface.
- Shafting material.
- Space on the shaft.
- Shaft orientation (Vertical, Horizontal).
- Ease of installation.

### SINGLE SIDED (SINGLE LOCK) SETSCREW LOCKING SYSTEM

Single sided set screw lock has an extended inner ring on one side of the bearing. This locking system is held to the shaft by two set screws. Single lock is the most popular bearing mounting method for Sealmaster Ball Bearings and is also available for Sealmaster RPB Tapered Roller Bearings. It is easy to mount because it requires tightening only two set screws and takes up minimal space along the shaft. Sealmaster Ball Bearings have a unique package of features including: wide inner ring design, zone hardened inner rings, specially designed setscrews and 120° set screw position. These features are unmatched in the mounted bearing industry and are designed to maximize lock reliability.



Sealmaster RPB Tapered Roller Bearings incorporate a concentric collar that fits over the inner ring extension. The collar is threaded to accept set screws which are located at 120°. The set screws pass through the inner ring holes and contact the shaft.

Single lock set screw design is specified in a wide range of applications for moderate loads and speeds. This lock is sometimes specified in flange block and cartridge housings because of inaccessibility of back side set screws. **Upset set screw marks on the shaft can be minimized for removal of the bearing by removing the set screws and using a flat punch, tapping the upset shaft material flat onto the shaft.** For high speed, heavy load (radial or thrust), vibration, eccentric loading, stainless steel or hollow shafting, reduction of fretting, vibration or marking of the shafting, review alternate locks below or consult Sealmaster Application Engineering. (630-898-9620)

### DOUBLE SIDED (DOUBLE LOCK) SET SCREW LOCKING SYSTEM

Double sided set screw lock is extended on both sides of the inner ring. The inner race is locked to the shaft by four screws. This design is the preferred lock for the heavy duty Sealmaster RPB Tapered Roller Bearing. Sealmaster Ball Bearings with double lock incorporate the same unique package of locking features included in the single lock design: wide inner ring design, zone hardened inner rings, specially designed set screws, and 120° set screw position.

Sealmaster RPB Tapered Roller Bearings incorporate a concentric collar that fits over the inner ring extension. The collar is threaded to accept set screws which are located at 120°. The set screws pass through the inner ring holes and to lock to the shaft.



The double lock design is specified for demanding applications or where shaft lock reliability is critical. This design is often specified on high load applications, high thrust load applications, vertical shafts where extra holding power is required, eccentric drive applications, high vibration applications, and high speed applications. Double lock increases lock reliability on stainless steel shafting. It also helps to reduce fretting corrosion on the shaft. Upset set screw marks on the shaft can be minimized for removal of the bearing by removing the set screws and, using a flat punch, tapping the upset shaft material flat onto the shaft. For stainless steel shafting, or where vibration reduction is required, refer to Skwezloc locking below or consult Sealmaster Application Engineering.

### SKWEZLOC LOCKING SYSTEM

Sealmaster Skwezloc locking system for ball bearings has an inner ring extension which is slit into 6 tangs. The split Skwezloc collar is tightened over the inner ring extension, gripping the bearing to the shaft. The Skwezloc design friction grips to the shaft with 360° of holding.



### THE SKWEZLOC LOCKING SYSTEM

- Centers the shaft in the bore of the bearing, reducing vibration and shaft runout.
- Maintains manufactured ball path roundness reducing vibration and enhances bearing life.
- Excellent for high speed applications
- Does not mark the shaft like set screw or eccentric lock.
- Is easy to install, requiring tightening only one Torx head capscrew.

Skwezloc is often specified in air handling, HVAC, fan and blower applications where noise and vibration reduction is essential. High speed applications such as saws and routers or high speed spindles are natural applications for Skwezloc locking. Coating roll and sanding applications are also good applications for the Skwezloc where runout control of the rotating system is essential. Skwezloc is recommended for stainless steel or hardened shafting. In vertical shaft or high thrust load applications, a thrust collar or axial locating device is required to insure safety of the friction grip lock.

Table No. 11

SHAFT LOCK COMPARISON			
CHARACTERISTIC	SINGLE LOCK	DOUBLE LOCK	SKWEZLOC
High Speeds	✓✓	✓✓✓	✓✓✓✓
Heavy Loads	✓✓	✓✓✓✓	✓✓✓✓
Radial Loads	✓✓✓✓	✓✓✓✓	✓✓✓✓
Thrust Loads	✓✓✓	✓✓✓✓	✓✓*
Fretting Control	✓✓	✓✓✓	✓✓✓✓
Run out Control	✓✓	✓✓	✓✓✓✓
Reliability of Lock	✓✓✓	✓✓✓✓	✓✓✓✓
Vertical Shaft	✓✓✓	✓✓✓✓	✓✓*
Eccentric Loads	✓✓	✓✓✓✓	✓✓✓
Hardened/Stainless Shafts	✓✓	✓✓✓	✓✓✓✓

**Legend:** Excellent 3 3 3 3, Good 3 3 3, Fair 3 3, Poor 3  
 w Review use of thrust device.

Note: Sealmaster premium locking systems are not intended to be a fix for worn, damaged or undersized shafting or poor mounting practices. Consult Sealmaster Installation Instructions for proper installation. (See pages 200-205).

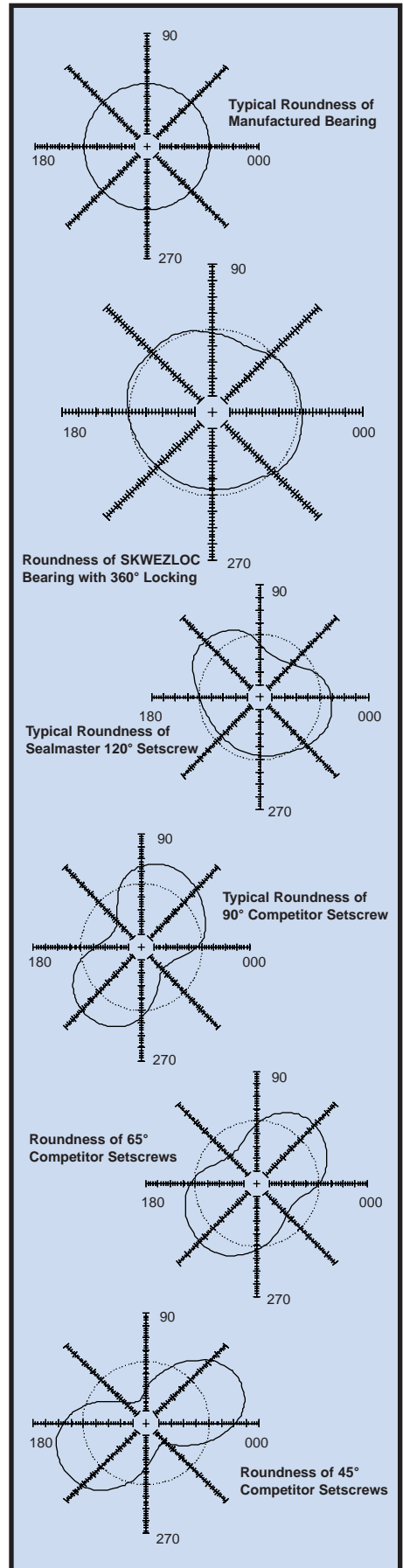

### BALL BEARINGS

Ball bearings create a point contact between the ball-path and rolling element distributing loads across a small area. Surface contact is minimized and less friction and heat is generated which gives ball bearings a higher speed range.

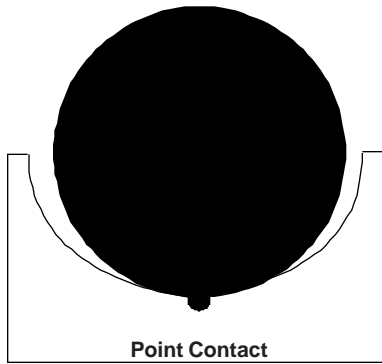

### TAPERED ROLLER BEARINGS

Tapered roller bearings create a line contact between the raceway and rolling element distributing loads across a larger area. Also, a double row provides twice as many rolling elements available to carry bearing load which increases bearing load capacity. Because tapered roller bearings are set at an angle, they can accept heavy loads from both the radial (Y) and thrust (X) directions.

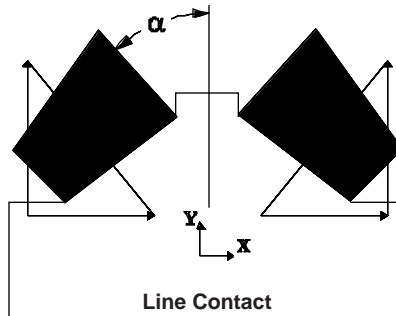

### ROD ENDS AND SPHERICAL BEARINGS

Spherical bearings are friction bearings. There are two surface areas in contact rubbing against each other. This generates large amounts of heat which limits rotation, but bearing configuration allows for large misalignment angles and oscillation.

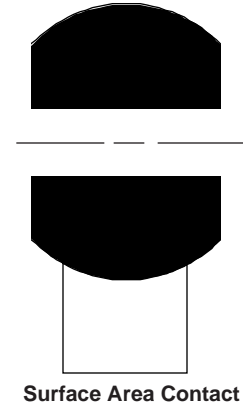

Table No. 12 Bearing Comparison

BEARING TYPE COMPARISON			
CHARACTERISTIC	GOLD LINE BALL BEARING	"RPB" SELF-ALIGNING TAPERED ROLLER BEARING	SEALMASTER ROD ENDS
High Speeds	✓✓✓✓	✓✓✓	-
Heavy Loads	✓✓	✓✓✓✓	✓✓✓✓
Radial Loads	✓✓✓✓	✓✓✓✓	✓✓✓✓
Thrust Loads	✓✓	✓✓✓✓	✓✓
Static Misalignment	✓✓✓✓	✓✓✓✓	✓✓✓✓
Dynamic Misalignment	✓	✓	✓✓✓✓
Rotation	✓✓✓✓	✓✓✓✓	✓
Oscillation	✓	✓	✓✓✓✓

Legend: Excellent 3 3 3 3, Good 3 3 3, Fair 3 3, Poor 3  
Columns marked "-" are unacceptable.

### BEARING FUNCTION

Bearings have three basic functions:

1. Support shaft and its associated load
2. Allow for shaft or housing rotation
3. Minimize frictional losses

Mounted bearings are self contained unitized assemblies. They facilitate assembly and replacement by having their own housing and by their slip-fit mount to shafting.

### LOADING

Bearings can support a combination of radial and thrust loads.

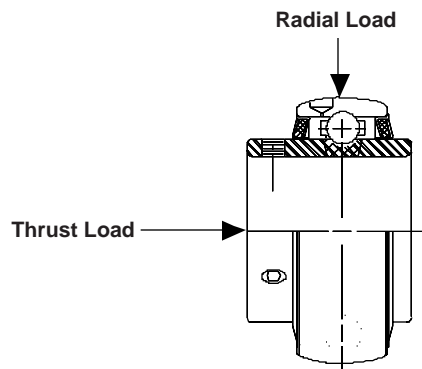

### MISALIGNMENT

#### Internal Bearing Misalignment...

Because of small clearance between the rolling elements and raceway, bearings can misalign a slight amount internally.

#### External Bearing Misalignment...

Angular movement in the radial direction of the entire insert relative to the housing. Static misalignment will induce external bearing misalignment.

#### Static System Misalignment...

Bearings mounted on different planes causing an angular shaft displacement.

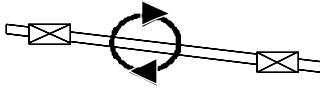

#### Dynamic System Misalignment...

Eccentric shaft rotation caused by shafting imperfections.

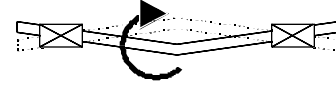

### BEARING CLEARANCES

Anti-Friction bearings are manufactured with specific clearances between the raceways and rolling elements. The clearances are designed for normal operating temperatures and application conditions.

Ball bearing clearances are measured in the radial direction when the insert is manufactured. Clearances are measured by fixing the outer ring and measuring the total movement of the inner ring in the radial direction.

Tapered roller bearing clearances are measured in the axial direction (end play) when the insert is manufactured. Clearances are measured by fixing the cup and measuring the total movement of the cone in the axial direction.

Various standard clearance ranges are available for Sealmaster Bearings.

**Table No. 13a Bearing Clearance**

Characteristic	Ball Bearing Clearance *
Vibration	Tight *
Light Load	Tight *
Standard Applications	Standard *
High Speed	Loose *
High Temperature	Loose *
Misalignment	Loose *

**Table No. 13b Bearing Clearance**

Characteristic	Tapered Roller Bearing Clearance *
Vibration	Standard *
Light Load	Standard *
High Speed	Standard *
High Temperature	Standard *
Vertical Shaft/W Vibration or Unbalance	Tight *

### HOUSING FIT-UP

Sealmaster Bearings are manufactured with specific fit-ups between the spherical O.D. outer ring (or cup) and the housing I.D. This fit-up is measured in torque required to misalign the bearing in the housing. Various housing fit-up ranges are available for Sealmaster Bearings:

Standard Fit - For most applications

Hand Fit (Ball only) - Where minimal misalignment torque can be tolerated

"AC" (Ball)/ "AH" (Tapered Roller)-Reduced fit-up torque for high speed, fan or other applications where reduced fit-up torque is preferred

Tight-Fit - Specified for shock/vibration applications.

**Table No. 14 Housing Fit-Up**

Characteristic	Ball Bearing Fit-Ups *	Tapered Roller Fit-Ups *
Vibration/Shock	Tight *	Tight *
Standard Applications	Standard	Standard
Fan	"AC" *	"AH" *
High Speed	"AC" *	"AH" *
Vertical Shaft/Vibration	Tight *	"AH" *

\* General Recommendations Only. Consult Sealmaster Application Engineering for your particular application.



## GOLD LINE BALL BEARINGS VIBRATION ANALYSIS

The following equations are used to calculate the fundamental frequencies for Sealmaster Ball Bearings.

1. If the Sealmaster insert number is known, proceed to step 2. For housed units, identify the bearing insert number by looking up the unit in the dimension tables, then proceed to step 2.
2. Find the Sealmaster insert number in Table No. 15 below and identify the series.
3. Select the vibration geometry information (O, I, B, F) from Table No. 16.
4. Use this information to calculate the fundamental bearing frequencies:

$$\begin{aligned} \text{Outer Ball Pass Frequency (Hz)} &= O \times \text{RPM} \\ \text{Inner Ball Pass Frequency (Hz)} &= I \times \text{RPM} \\ \text{Ball Spin Frequency (Hz)} &= B \times \text{RPM} \\ \text{Fundamental Train Frequency (Hz)} &= F \times \text{RPM} \end{aligned}$$

Symbol	Description	Units
RPM	Revolutions per Minute	RPM
O	Outer Race Frequency Factor.	
I	Inner Race Frequency Factor.	
B	Ball Spin Frequency Factor.	
F	Fundamental Train Frequency Factor.	

**Table No. 15 Gold line Insert Series**

SERIES	GOLDLINE INSERT SERIES							
2-012	2-08	2-09	2-010	2-011	2-012	5204	-	-
2-015	2-013	2-014	2-015	5205	2-1	3-012	-	-
2-13	2-11	2-12	2-13	5206	1-14	3-015	5305	3-1
2-17	2-14	2-15	5207	2-16	2-17	1-18	5306	3-13
2-19	2-18	2-19	5208	1-110	5307	3-17	-	-
2-111	2-110	2-111	2-112	5209	3-18	5308	-	-
2-115	2-113	2-114	2-115	5210	1-2	3-111	3-112	5309
2-23	2-2	2-22	5211	2-23	3-115	5310	-	-
2-27	2-24	2-25	5212	2-26	2-27	5311	3-23	-
2-211	2-210	2-211	2-212	5214	3-27	3-28	5313	-
2-215	2-213	2-214	2-215	5215	3-211	3-212	5314	-
2-33	5216	2-33	3-215	5315	3-3	-	-	-
2-37	2-34	2-36	2-37	5316	3-33	-	-	-
2-38	2-38	5218	3-37	-	-	-	-	-
2-43	2-43	5320	3-315	3-4	-	-	-	-
3-47	2-5	3-47	3-415	-	-	-	-	-

**Table No. 16 Vibration Geometry/Information**

SERIES	PITCH DIAMETER (IN.)	NUMBER OF BALLS	SIZE OF BALLS (INS.)	FACTOR FOR OUTER RACE FREQ.	FACTOR FOR INNER RACE FREQ.	FACTOR FOR BALL SPIN FREQ.	FACTOR FOR F.T.F.
			D	O	I	B	F
2-012	1.345	9	9/32	0.0593	0.0907	0.0381	0.0066
2-015	1.544	10	9/32	0.0682	0.0985	0.0442	0.0068
2-13	1.812	9	3/8	0.0595	0.0905	0.0385	0.0066
2-17	2.115	9	7/16	0.0595	0.0905	0.0386	0.0066
2-19	2.362	9	1/2	0.0591	0.0909	0.0376	0.0066
2-111	2.596	10	1/2	0.0673	0.0994	0.0417	0.0067
2-115	2.763	10	1/2	0.0683	0.0984	0.0445	0.0068
2-23	3.051	10	9/16	0.0680	0.0987	0.0437	0.0068
2-27	3.356	10	5/8	0.0678	0.0989	0.0432	0.0068
2-211	3.846	10	11/16	0.0684	0.0982	0.0451	0.0068
2-215	4.045	11	11/16	0.0761	0.1072	0.0476	0.0069
2-33	4.362	11	3/4	0.0759	0.1074	0.0470	0.0069
2-37	4.627	11	25/32	0.0762	0.1071	0.0479	0.0069
2-38	4.922	10	7/8	0.0685	0.0981	0.0454	0.0069
2-43	5.808	10	1 1/16	0.0681	0.0986	0.0440	0.0068
3-47	7.087	10	1 1/4	0.0686	0.0980	0.0458	0.0069

Contact SEALMASTER Application Engineering for additional details.

### GOLD LINE TAPERED ROLLER BEARINGS VIBRATION ANALYSIS

The following equations are used to calculate the fundamental frequencies for Sealmaster RPB Tapered Roller Bearings.

1. All information can be linked to three factors:

- Shaft Size
- Unit number For RPB-208-C2; the unit number is "208".
- Insert number For RPB-104-2; the insert number is "RCI-104".

2. Use the information obtained from step 1 to select the vibration geometry information (O, I, B, F, and G) from Table No. 17.

3. Use this information to calculate the fundamental bearing frequencies:

- Roller Spin Frequency (Hz) =  $O \times \text{RPM}$
- Inner Roller Pass Frequency (Hz) =  $I \times \text{RPM}$
- Outer Roller Pass Frequency (Hz) =  $B \times \text{RPM}$
- Fundamental Train Frequency (Hz); shaft rotation =  $F \times \text{RPM}$
- Fundamental Train Frequency (Hz); housing rotation =  $G \times \text{RPM}$

Symbol	Description	Units
Z	Number of Rollers/row	integer
RPM	Revolutions per Minute	RPM
O	Roller Spin Frequency Factor.	
I	Inner Roller Pass Frequency Factor.	
B	Outer Roller Pass Frequency Factor.	
F	Factor for Fundamental Train (Shaft Rot).	
G	Factor for Fundamental Train (Hsg.Rot)	

**Table No. 17** Vibration Geometry Information

SHAFT SIZE	UNIT NO.	INSERT NO.	FACTOR FOR	FACTOR FOR	FACTOR FOR	FACTOR FOR	FACTOR FOR	NUMBER OF
			ROLLER SPIN O	INNER ROLLER PASS I	OUTER ROLLER PASS B	FUND. TRAIN (SHAFT ROT.) F	FUND. TRAIN (HSG. ROT.) G	
1 3/16	103	RCI-103	0.12580	0.17823	0.13844	0.00729	0.00938	19
1 1/4	104	RCI-104	0.12580	0.17823	0.13844	0.00729	0.00938	19
1 3/8	106	RCI-106	0.11732	0.18917	0.14416	0.00721	0.00946	20
1 7/16	107	RCI-107	0.11732	0.18917	0.14416	0.00721	0.00946	20
1 1/2	108	RCI-108	0.11320	0.17101	0.12899	0.00717	0.00950	18
1 5/8	110	RCI-110	0.11320	0.17101	0.12899	0.00717	0.00950	18
1 11/16	111	RCI-111	0.11320	0.17101	0.12899	0.00717	0.00950	18
1 3/4	112	RCI-112	0.10828	0.16264	0.12069	0.00710	0.00957	17
1 15/16	115	RCI-115	0.10828	0.16264	0.12069	0.00710	0.00957	17
2	200	RCI-200	0.10828	0.16264	0.12069	0.00710	0.00957	17
2 3/16	203	RCI-203	0.12160	0.17921	0.13745	0.00724	0.00943	19
2 1/4	204	RCI-204	0.13446	0.19584	0.15416	0.00734	0.00933	21
2 7/16	207	RCI-207	0.13446	0.19584	0.15416	0.00734	0.00933	21
2 1/2	208	RCI-208	0.13446	0.19584	0.15416	0.00734	0.00933	21
2 11/16	211	RCI-211	0.15781	0.22018	0.17982	0.00749	0.00917	24
2 3/4	212	RCI-212	0.15781	0.22018	0.17982	0.00749	0.00917	24
2 15/16	215	RCI-215	0.15781	0.22018	0.17982	0.00749	0.00917	24
3	300	RCI-300	0.15781	0.22018	0.17982	0.00749	0.00917	24
3 3/16	303	RCI-303	0.17061	0.23678	0.19656	0.00756	0.00911	26
3 7/16	307	RCI-307	0.17061	0.23678	0.19656	0.00756	0.00911	26
3 1/2	308	RCI-308	0.17061	0.23678	0.19656	0.00756	0.00911	26
3 15/16	315	RCI-315	0.16448	0.23758	0.19576	0.00753	0.00914	26
4	400	RCI-400	0.16448	0.23758	0.19576	0.00753	0.00914	26
4 7/16	407	RCI-407	0.16005	0.22885	0.18781	0.00751	0.00915	25
4 1/2	408	RCI-408	0.16005	0.22885	0.18781	0.00751	0.00915	25
4 15/16	415	RCI-415	0.15868	0.22922	0.18745	0.0075	0.00917	25
5	500	RCI-500	0.15868	0.22922	0.18745	0.0075	0.00917	25

Contact SEALMASTER Application Engineering for additional details.

## BALL AND ROLLER BEARINGS

### INTRODUCTION

Lubricant is a basic element in rolling element bearings. It is as essential to proper operation as are the races and rolling elements. Oil provides a separating layer between rolling elements and raceways and lubricates the sliding surfaces between the rolling elements and retainer. This lubricating layer eliminates or minimizes metal to metal contact and distributes stresses. Lubrication can also provide protection against corrosion, a barrier to contamination, and dissipation of heat.

### GREASE

Grease is the primary lubricant used in most industrial mounted bearing units. Grease usually consists of three primary components: oil, thickener, and additives.

Grease comes in various thicknesses. Standard bearings are generally packed with grease of NLGI-grade 2 thickness. For most applications this grade is sufficient for retention in the bearing, is easily pumped through most grease guns, and operate under most speed conditions. Other greases can be used for special situations.

### THICKENERS

The thickener's primary purposes are to retain the oil so that it remains in the bearing, release the oil as needed, and reabsorb the oil as needed. The thickener can also provide additional sealing and protection from contamination and heat dissipation. There are many types of grease thickeners including lithium, calcium, sodium, aluminum, etc. Lithium thickeners are the most common type with the others being useful in specialized situations, such as high temperature, low drag, and low temperature, etc.

### OIL

Oil is the primary lubricating component in grease and consists of two types: petroleum and synthetic. Petroleum oils are the primary oils used today. Synthetic hydrocarbons can be thought of as synthetic petroleum oils. Other synthetics include esters, silicones, fluorinated hydrocarbons, etc.

Oil is a fluid and can be obtained in varying viscosities. Viscosity refers to the "thickness" of the oil and is usually directly related to an oil's shear strength or its ability to resist loading.

Elastohydrodynamic (EHL) lubrication is the model that explains the lubrication of anti-friction bearings. EHL takes into account the deformation of the rolling elements and raceways as well as the increased viscosity of the lubricant in the load zone.

In a rotating rolling element bearing there is one of (3) types of lubrication conditions present; 1.) Boundary 2.) thin film 3.) thick film. Bearing operating speed is an important element in determining the lubrication condition. Boundary lubrication occurs when there is metal on metal contact between rolling elements and races. This may be due to low speed and/or oil viscosity too low to separate the surfaces. Boundary lubrication is the most severe condition for anti-friction bearings and distress of the rolling elements and races will occur. In the thin film condition, partial separation of the surfaces of the rolling elements and races occur with some asperities in contact. This condition may be due to low speed and/or oil viscosity too low to separate the surfaces completely. Some distress of the bearing surfaces will take place in thin film lubrication. Thick film lubrication is the preferred condition for optimum bearing performance. The speed of the bearing and/or the lubricant viscosity is sufficient to separate the rolling elements and raceways. Higher viscosity oils (or higher operating speeds) can help to attain the thick film lubrication condition, but excessively high oil viscosities may lead to higher operating temperatures from churning of the oil or skidding of the rolling elements. Lower viscosity oils sufficient to attain a thick film lubrication condition at the operating speed are selected in high speed applications as they have less tendency to churn or cause skidding.

### ADDITIVES

Greases also contain additives. These additives may increase load capacity, resist corrosion, resist temperature extremes, resist oxidation, effect oil viscosity, thickener consistency characteristics, as well as many other characteristics.

Consult Sealmaster Application Engineering when using EP additives or other solid additives such as molybdenum disulfide, graphite, brass, nickel, etc.

### COMPATIBILITY

Combinations of different types of thickeners (soaps) may cause reactions that can reduce bearing performance.

Petroleum oils and synthetic hydrocarbons are, generally speaking, compatible. Other synthetic oils are, more often than not, incompatible with other oils.

Additives may cause compatibility problems in some cases.

Caution should be used when relubricating with or combining different greases. Contact Sealmaster Application Engineering for current grease specifications and your grease manufacturer to verify grease compatibility.

### OIL SATURATED POLYMER (OSP)

Oil saturated polymers are generally porous plastics that retain oil and are used in place of grease. This option may be used in inaccessible areas where relubrication is difficult. Sealmaster's solid lubricant OSP is an option in these applications since OSP can hold more oil in the bearing chamber, thus providing a longer lived lubricant supply. OSP should not be used over 200° F.

### FOOD GRADE GREASE

"Food Grade" grease is an option in all Sealmaster Bearings. Consult Sealmaster Application Engineering for current specifications.

### REDUCED MAINTENANCE

Some bearings are considered "lubricated for life" and are not provided with provisions for relubrication. This type of bearing may be limited by the life of the original grease fill and the ability of the seals to protect the bearing from contamination. Sealmaster has many seal and grease options for lubricated for life bearings.

### HIGH TEMPERATURE GREASE

High temperature greases are available in Sealmaster ball and roller Bearings. Sealmaster tapered roller bearings are lubricated with a lithium complex soap and synthetic hydrocarbon oil grease (N suffix). Sealmaster ball bearings can be specified with silicone oil or synthetic hydrocarbon oil greases, or other options. Consult Sealmaster Application Engineering for proper lubricant for your application.

Contact SEALMASTER Application Engineering for further information.

### LUBRICANT

\* Most Sealmaster bearing product lines are lubricated at the factory with a high quality NLGI #2 grease as follows:

	BALL	TAPERED ROLLER
Thickener (Soap)	Lithium Complex	Lithium Calcium
Oil	Petroleum	Petroleum
High Temperature	Optional *	Lithium Complex/Synthetic Hydrocarbon (N Suffix)

These greases were selected to provide high performance in general applications operating at -20 to 200° F (intermittent to 250° F). The high viscosity index oils in these greases include additive packages to provide oxidation stability and corrosion protection.

\* Some Sealmaster Bearings are used in applications where a specialty lubricant is required. These include:

- HF - HFT Bearings
- Corrosion Duty Bearings
- High Temperature Bearings (Including RPB-xxxN)
- Low Drag Bearings
- Low Temperature Bearings

\* Grease specified may change from time to time, consult Sealmaster Application Engineering for current specifications.

### RELUBRICATION

\* Most Sealmaster Bearings can be relubricated with a high quality NLGI #2, lithium soap grease with petroleum oil.

\* Compatibility of grease is critical, therefore consult with Sealmaster Application Engineering for current grease specifications and your grease supplier to insure greases are compatible.

Greases should always be stored in a clean, dry area and carefully protected from any contaminants.

Relubricatable Sealmaster Bearings are supplied with grease fittings or zerks for ease of lubrication. (See page 198) with hand or automatic grease guns. Always wipe the fitting and grease gun nozzle clean. For safety, stop rotating equipment. Add grease slowly until a small bead of grease is present at the seals. Start equipment slowly, if more purging of the grease is necessary, stop equipment and repeat above.

A temperature rise (sometimes 30° F) after relubrication is normal. Typically the temperature will decrease after a short operating time when excess grease has purged and bearing has stabilized.

## RECOMMENDED RELUBRICATION SCHEDULE

**Table No. 18 Ball Bearings**

LUBRICATION INSTRUCTIONS			
SPEED	TEMPERATURE	CLEANLINESS	GREASING INTERVALS
100 RPM	Up to 120°F	Clean	6 to 12 Months
500 RPM	Up to 150°F	Clean	2 to 6 Months
1000 RPM	Up to 210°F	Clean	2 Weeks to 2 Months
1500 RPM	Over 210°F - 250°F	Clean	Weekly
1500 to Max. Catalog Rating	Up to 150°F	Dirty	1 Week to 1 Month
	Over 150°F - 250°F	Dirty	Daily to 2 Weeks
	Up to - 250°F	Very Dirty	Daily to 2 Weeks
	Up to - 250° F	Extreme Conditions	Daily to 2 Weeks

**Table No. 20 Roller Bearings**

ROLLER LUBRICATION INSTRUCTIONS			
SPEED	TEMPERATURE	CLEANLINESS	GREASING INTERVALS
100 RPM	Up to 125°F	Clean	6 Months
500 RPM	Up to 150°F	Clean	2 Months
1000 RPM	Up to 210°F	Clean	2 Weeks
1500 to Max. Catalog Rating	Up to 150°F	Dirty	1 Week to 1 Month
	Over 150°F	Dirty	Daily to 1 Week
	Up to - 250°	Very Dirty	Daily to 1 Week
	Up to - 250°	Extreme Conditions	Daily to 1 Week

**Table No. 19**

LUBRICATION OF SEALMASTER BALL BEARINGS	
SHAFT SIZE (INCHES)	RECOMMENDED RELUBRICATION GREASE CHARGE (OUNCES)
1/2 - 3/4	.02
7/8 - 1 3/16	.06
1 1/4 - 1 1/2	.09
1 11/16 - 1 15/16	.19
2 - 2 7/16	.28
2 1/2 - 2 15/16	.50
3 - 3 7/16	1.00
3 1/2 - 4	1.70
4 3/16 - 4 15/16	3.0

**Table No. 21**

LUBRICATION OF RPB ROLLER BEARINGS	
SHAFT SIZE (INCHES)	RECOMMENDED RELUBRICATION GREASE CHARGE (OUNCES)
1 3/16 - 1 1/4	.10
1 3/8 - 1 7/16	.22
1 1/2 - 1 11/16	.32
1 3/4 - 2	.50
2 3/16	.55
2 1/4 - 2 1/2	.65
2 11/16 - 3	.85
3 3/16 - 3 1/2	1.25
3 15/16 - 4	2.50
4 7/16 - 4 1/2	3.10
4 15/16 - 5	4.75

**These charts are general recommendations. Experience and testing may be required for specific applications. For speeds, temperatures and conditions not listed in these tables, contact Sealmaster Application Engineering at 630-898-9620.**

Refer to Page 182 for relevant disclaimer.

**LUBRICATION FITTING**

Lubrication fittings are provided on most Sealmaster Mounted Bearings. The grease fitting provides a means for adding fresh lubricant to the bearing.

Ball Bearings - The lubrication fitting on Sealmaster Goldline Ball Bearings also functions to position the lock pin utilized in the unique lock pin and dimple system.

Adjustment or Replacement of the fitting may result in the bearing not performing to expectations. When using lube lines, an adapter is recommended to insure proper lock pin positioning.

**Standard Lubrication Fittings**

**Ball Bearings** - See Opposite Page 199.

**Roller Bearings**

Every Sealmaster RPB Tapered Roller Bearing has a style "B" lubrication fitting. When replacing cartridge inserts always check to be sure that the rubber grommet is located in the recess beneath the housing cap. This ensures positive lubrication flow into the bearing insert.

**Rod Ends**

Sealmaster Rod Ends can be ordered with a lubrication fitting. Attach the suffix "N" to specify zerk type threaded grease fittings or the suffix "FN" to specify a flush type fitting. Table No. 22 indicates thread size for rod end grease fittings.

**Table No. 22**

BORE SIZE (INCHES)	THREAD
1/4 - 7/16	6-40 UNF
1/2 - 1	10-32 UNF

**Optional Fittings**

Optional fittings can be ordered factory installed to meet most customer requirements. Some of the optional fittings are shown at the right. Other optional fittings include:

- Connectors for lube lines
- Button head fittings
- Relief fittings
- Angled adapter fittings

**Table No. 23 FITTING STYLES**

<p><b>STYLE "A"</b></p> <p>5/16 HEX</p> <p>1/4" - 28 NF Taper Thd. (SAE-Lt)</p>	<p><b>STYLE "B"</b></p> <p>7/16 HEX</p> <p>1/8" P.T.F. SAE Spec. Extra Short</p>
<p><b>STYLE "C"</b></p> <p>9/16 HEX</p> <p>1/4" P.T.F. SAE Spec. Extra Short</p>	<p><b>STYLE "D"</b></p> <p>90°</p> <p>3/8 HEX</p> <p>1/4" - 28NF Taper Thd. (SAE-Lt)</p>
<p><b>STYLE "E"</b></p> <p>90°</p> <p>7/16 HEX</p> <p>1/8" P.T.F. SAE Spec. Short</p>	<p><b>STYLE "F"</b></p> <p>1/8 N.P.T.F.</p> <p>9/16 HEX</p> <p>1/4" N.P.T.F.</p>
<p><b>STYLE "G"</b></p> <p>1/8 HEX</p> <p>1/4" - 28 NF / 1/8 P.T.F.</p>	<p><b>STYLE "H"</b></p> <p>1/8 N.P.T.F.</p> <p>1/2 HEX</p> <p>1/8" N.P.T.F. SAE Spec. Short</p>

**Table No. 24 Gold Line Ball Bearings**

UNITS		LUBRICATION FITTING CHART								
STD. DUTY	MED. DUTY	BORE SIZES								
		1/2 - 3/4	15/16 - 1 7/16	1 1/2	1 11/16 - 1 3/4	1 13/16 - 2 1/8	2 3/16 - 2 7/16	2 1/2 - 2 11/16	2 15/16	3 AND UP
-	EMP	-	A	A	A	B	B	B	B	C
-	EMP-T	-	A	A	A	B	B	-	-	-
-	EMSF	-	-	B	B	B	B	B	C	C
-	EMSF-T	-	-	B	B	B	B	-	-	-
ENP	-	A	A	A	A	B	-	-	-	-
ENP-T	-	A	A	A	A	B	B	-	-	-
ESF	-	A	A	A	A	B	B	B	B	-
ESF-T	-	A	A	A	A	B	B	-	-	-
ETXP	-	-	B	B	B	B	B	-	-	-
FB	-	A	A	-	-	B	-	-	-	-
FB-T	-	A	A	-	-	B	-	-	-	-
-	MFC	-	A	A	B	B	B	B	C	C
-	MFC-T	-	A	A	B	B	B	-	-	-
-	MFP	-	-	-	-	B	B	B	C	C
-	MP	-	A	A	B	B	B	B	C	C
-	MP-T	-	A	A	B	B	B	-	-	-
-	MPD	-	A	A	B	B	B	B	C	C
-	MSC	-	A	A	A	A	B	B	B	B
-	MSC-T	-	A	A	A	A	B	-	-	-
-	MSF	-	A	A	B	B	B	B	C	C
-	MSF-T	-	A	A	B	B	B	-	-	-
-	MSFPD	-	-	-	-	-	-	-	-	-
-	MSFT	-	A	A	-	B	-	-	-	-
-	MSFT-T	-	A	A	-	B	-	-	-	-
-	MSPD	-	-	-	-	-	-	-	-	-
-	MST	-	D	D	E	E	E	E	E + F	E + F
-	MST-T	-	D	D	E	E	E	-	-	-
NP	-	A	A	A	A	B	B	-	-	-
NP-T	-	A	A	A	A	B	B	-	-	-
NPD	-	A	A	A	A	B	B	-	-	-
NPL	-	A	A	A	A	B	B	-	-	-
NPL-T	-	A	A	A	A	B	B	-	-	-
SC	-	A	A	A	A	A	A	B	B	-
SC-T	-	A	A	A	A	A	A	-	-	-
SCHB	-	-	G	G	H	H	H	H	H	F
SEHB	-	A	A	A	B	B	B	B	B	C
SF	-	A	A	A	A	B	B	B	B	-
SF-T	-	A	A	A	A	B	B	-	-	-
SFC	-	-	A	A	A	B	B	B	B	C
SFC-T	-	-	A	A	A	B	B	-	-	-
SFT	-	A	A	A	A	B	B	B	B	C
SFT-T	-	A	A	A	A	B	B	-	-	-
SP	-	-	A	A	A	B	B	B	B	C
SP-T	-	-	A	A	A	B	B	-	-	-
SPD	-	-	A	A	A	B	B	B	B	C
-	SPM	-	A	A	-	B	B	B	C	-
ST	-	D	D	D	E	E	E	E	E	E
ST-T	-	D	D	D	E	E	E	-	-	-
TB	-	A	A	A	A	B	-	-	-	-
TB-T	-	A	A	A	A	B	-	-	-	-
TFT	-	A	A	-	-	-	-	-	-	-
TXP	-	-	A	-	-	-	B	-	-	-

# INSTALLATION



## SHAFT MOUNTING INSTALLATION PROCEDURES FOR BALL AND ROLLER BEARINGS

Note: Setscrew marks on the shaft can be removed by backing out the setscrews and using a flat punch to tap down the setscrew burrs on the shaft.

### SETSCREW LOCKING:

#### INSPECT SHAFT

- Clean/remove burrs.
- Check diameter  
Reference Table No. 25, page 204.
- Clean Mounting Surface.



#### PLACE BEARING ON SHAFT

- Apply light film of oil on shaft.
- Do not hammer bearing onto shaft.



#### BOLT HOUSING TO SUPPORT SURFACE

- Bearing and shaft must be in alignment within 2°.
- Rotate shaft to make sure it turns smoothly.

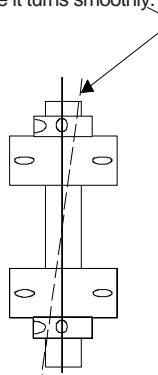

#### ALIGN SETSCREWS ON EITHER END OF SHAFT

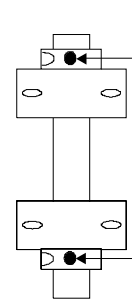

#### ALTERNATE TORQUING OF SETSCREWS

- Step 1: Torque setscrew "A" to 1/2 recommended torque.
- Step 2: Torque setscrew "B" to full recommended torque.
- Step 3: Torque setscrew "A" to full recommended torque.  
(Reference "Tighten to" column in Table No. 32 on page 205.
- Double Lock: Repeat on opposite end.

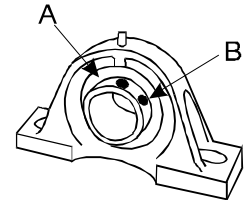

### SKWEZLOC® LOCKING COLLAR:

#### INSPECT SHAFT

- Clean/remove burrs.
- Check diameter  
Reference Table No. 25, page 204.
- Clean Mounting Surface.



#### PLACE BEARING ON SHAFT

- Do not hammer bearing onto shaft.



#### BOLT HOUSING TO SUPPORT SURFACE

- Bearing and shaft must be in alignment within 2°.
- Rotate shaft to make sure it turns smoothly.

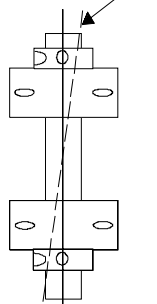

#### PUSH LOCKING COLLAR TIGHTLY AGAINST INNER RING SHOULDER

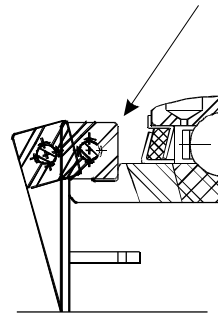

#### TORQUE CAPSCREW TO RECOMMENDED VALUE

(Reference "Tighten to" column in Table No. 32 on page 205.

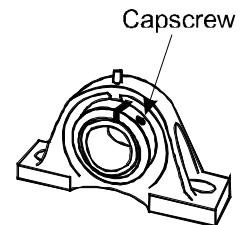

Reference "Note" on Page 201.

**▲WARNING**  
Failure to observe safety precautions could cause personal injury or equipment damage.

**▲WARNING**  
Do not operate without guards. Turn off power to install or service.

**▲CAUTION**  
High voltage and rotating parts may cause serious or fatal injury. Turn off power to install or service.

### SPHERICAL OD BEARING INSERT REMOVAL AND REPLACEMENT - BALL BEARING UNITS

Ball bearing spherical OD Insert removal and replacement procedure. Sealmaster Bearing Inserts are selectively fit into castings, therefore our engineering department recommends replacing entire unit.

#### REMOVAL:

##### 1 REMOVE BEARING FROM SHAFT

- Loosen set screws.
- Slide bearing off shaft.
- Do not hammer bearing onto shaft.



##### 2 REMOVE LUBRICATION FITTING

- Do not lose fitting.

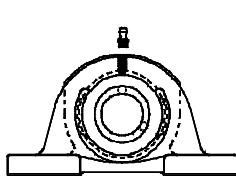

##### 3 REMOVE LOCK PIN

- Do not lose lock pin.
- Either:
  - Use magnet to retrieve pin.
  - Tip housing over and gently shake.

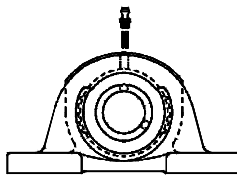

##### 4 ROTATE INSERT

- Rotate insert 90° relative to housing.
- A screw driver or wrench can aid as a lever.

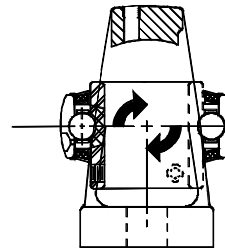

##### 5 REMOVE INSERT

- Push bearing through load slots.

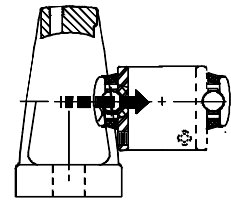

#### REPLACEMENT:

##### 1 LOAD INSERT

- Rotate insert 90° relative to housing.
- Push into housing through the load slots.

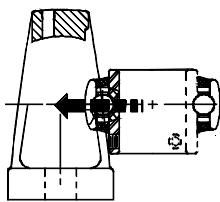

##### 2 ROTATE BEARING

- Rotate bearing back 90° relative to housing.
- Do not hammer bearing into housing.

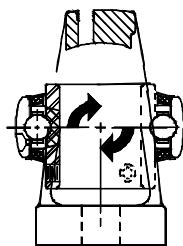

##### 3 ALIGN OUTER RACE DIMPLE

- Dimple must align with lube hole in casting to accommodate the locking pin.

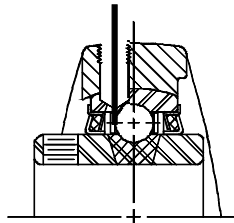

##### 4 REPLACE LOCK PIN

- Drop lock-pin into casting lubrication hole.

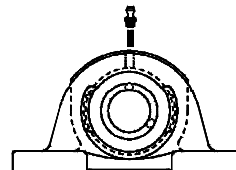

##### 5 REPLACE LUBRICATION FITTING

- Snug lubrication fitting.
- Back off lubrication fitting one half turn to relieve forces on lock pin.

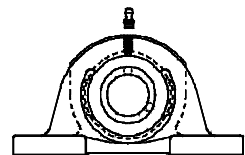

**NOTE:** Insert fit to housing is critical. Replace entire unit if: 1. housing bore appears worn. 2. Insert can be hand fit in housing. 3. Insert required bar with heavy force to align in housing.

**START-UP:** Start system slowly. Check for noises, vibration, etc. Bearings should not operate "hot" to hand touch in most applications. Inspect and repair as required if unusual conditions exist or consult Sealmaster Application Engineering.

#### ⚠ WARNING

Failure to observe safety precautions could cause personal injury or equipment damage.

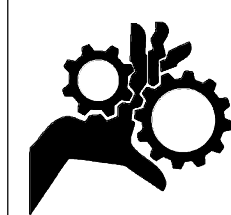

#### ⚠ WARNING

Do not operate without guards. Turn off power to install or service.

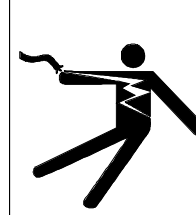

#### ⚠ CAUTION

High voltage and rotating parts may cause serious or fatal injury. Turn off power to install or service.



## INSTALLATION

### EXPANSION BEARING INSERT REMOVAL AND REPLACEMENT - BALL BEARING UNITS

Sealmaster bearing inserts are selectively fit into castings. Our experienced engineering department recommends replacing entire insert unit.

#### SETSCREW LOCKING:

##### 1 REMOVE BEARING FROM SHAFT

- Loosen set screws.
- Slide bearing off shaft.
- Do not hammer bearing off of shaft.



##### 2 REMOVE LUBRICATION FITTING

- Do not lose fitting.

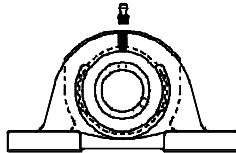

##### 3 REMOVE LOCK PIN

- Do not lose lock pin.
- Either:
  - Use magnet to retrieve pin.
  - Tip housing over and gently shake.

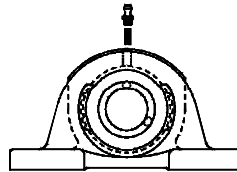

##### 4 REMOVE INSERT

- Insert should push straight out of housing.

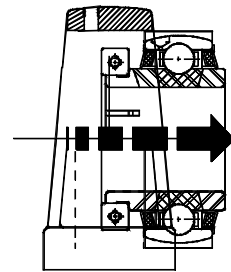

#### REPLACEMENT:

##### 1 LOAD INSERT

- Push bearing into housing.

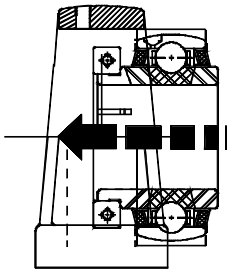

##### 2 ALIGN OUTER RACE DIMPLE

- Dimple must align with lube hole in casting to accommodate the locking pin.

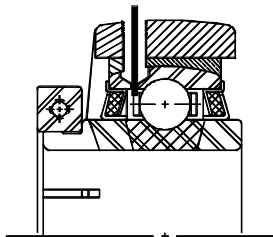

##### 3 REPLACE LOCK PIN

- Drop lock-pin into casting lubrication hole.

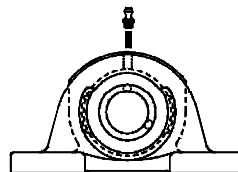

##### 4 REPLACE LOCK PIN

- Snug lubrication fitting.
- Back off lubrication fitting one half turn to relieve forces on lock pin.

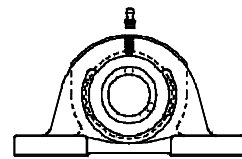

Reference "Start-Up" on Page 201.

**▲WARNING**  
Failure to observe safety precautions could cause personal injury or equipment damage.

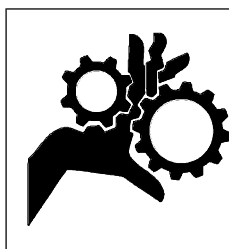

**▲WARNING**  
Do not operate without guards. Turn off power to install or service.

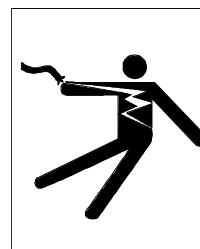

**▲CAUTION**  
High voltage and rotating parts may cause serious or fatal injury. Turn off power to install or service.

### SELF-ALIGNING TAPERED ROLLER BEARING INSERT REMOVAL AND REPLACEMENT



RCI Cartridge inserts with double or single locking collar. RCI fits Sealmaster RPB pillow blocks, flanges and piloted flange split housings.



ERCI Cartridge inserts designed to mount directly into customer housings and as inserts in expansion ERPB housings.

### RPB SERIES SELF-ALIGNING TAPERED ROLLER BEARINGS FIXED AND EXPANSION TYPE DESIGNS CARTRIDGE INSERT REMOVAL AND REPLACEMENT

#### REMOVE HOUSING CAP BOLTS

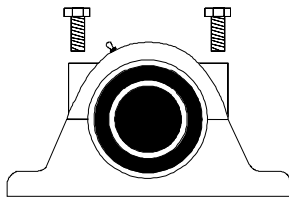

#### REMOVE TOP OF HOUSING

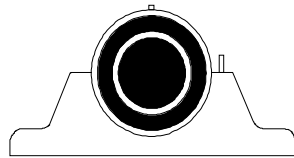

#### REMOVE BEARING FROM SHAFT

- Loosen set screws.
- Slide bearing off shaft.
- Do not hammer bearing off of shaft.



### REPLACEMENT:

#### LOAD NEW INSERT

- Slide bearing onto shaft.
- Seat bearing into housing.
- Position cartridge lock pin to line up with pin slot in housing.

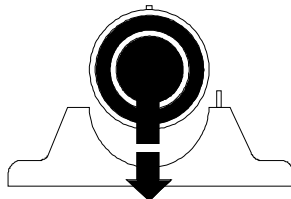

#### INSTALL TOP HOUSING HALF

- Align location pin with location hole.
- Insure rubber grommet is under grease fitting.

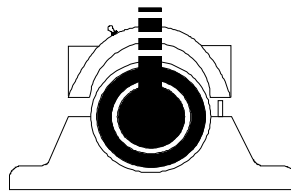

#### INSTALL HOUSING CAP BOLTS

- Tighten down to recommended torque (Refer to Table No. 31 on page 204).
- Rotate shaft to make sure it turns smoothly.

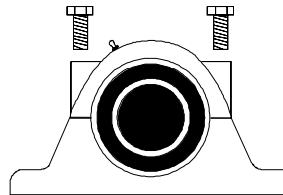

#### TORQUE SETSCREWS

- **Align setscrews on either end of shaft.**
- Secure one side on insert:
  - Step 1: Torque one setscrew to 1/2 recommended torque.
  - Step 2: Torque second setscrew to recommended torque.
  - Step 3: Torque first setscrew to full recommended torque. (Refer to "tighten to" column in Table no. 33 on page 205.)
- If applicable, secure second side of insert as above.

Reference "Note" on Page 201.

#### ▲WARNING

Failure to observe safety precautions could cause personal injury or equipment damage.

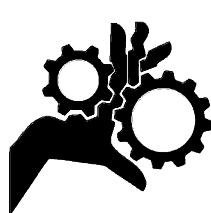

#### ▲WARNING

Do not operate without guards. Turn off power to install or service.

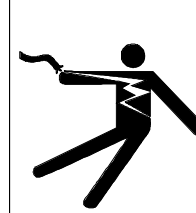

#### ▲CAUTION

High voltage and rotating parts may cause serious or fatal injury. Turn off power to install or service.

## BALL BEARINGS

Table No. 25

SHAFT TOLERANCES FOR BALL BEARINGS	
Shaft Diameter (in.)	Shaft Tolerance (in.)
1/2 - 1 15/16	Plus .0000 to minus .0005
2 - 3 3/16	Plus .0000 to minus .0010
3 1/4 - 4 15/16	Plus .0000 to minus .0015

Table No. 26

BORE TOLERANCES FOR BALL BEARINGS	
Shaft Diameter (in.)	Bore Tolerance (in.)
1/2 - 1 15/16	Plus .0006 to minus .0000
2 - 3 3/16	Plus .0006 to minus .0000
3 1/4 - 4 15/16	Plus .0007 to minus .0000

Table No. 27

HF & HFT SETSCREW SIZES FOR BALL BEARINGS	
Bore	Setscrew Size
1	1/4 - 28
1 3/16	1/4 - 28
1 1/4	1/4 - 28
1 7/16	5/16 - 24
1 1/2	5/16 - 24
1 3/4	5/16 - 24

Table No. 28

HIGH TEMPERATURE FURNACE BALL BEARINGS HEC SHAFT EXPANSION SLOT SIZES			
Bore Size	Square Head Setscrew	Depth (Inches)	Width (Inches)
1	1/4 - 28	0.25 - 0.28	0.28 - 0.31
1 3/16	1/4 - 28	0.25 - 0.28	0.28 - 0.31
1 1/4	1/4 - 28	0.25 - 0.28	0.28 - 0.31
1 7/16	5/16 - 24	0.30 - 0.33	0.34 - 0.37
1 1/2	5/16 - 24	0.30 - 0.33	0.34 - 0.37
1 3/4	5/16 - 24	0.30 - 0.33	0.34 - 0.37

## HIGH SPEED/HIGH LOAD APPLICATIONS

### High Load Applications

Applications where the loading approaches the load listed in the rating tables on pages 180, 181 and 183 at 5000 hours life and 150/250 RPM, should be reviewed and given special consideration.

Modifications to consider Include:

- Shafting size should be closely controlled for a line to line to a light press fit.
- Skwezloc or double lock is the preferred lock.
- Lubricants with "EP" extreme pressure additives may be required.
- Care in housing selection, load direction, and mounting techniques should be exercised.

## ROLLER BEARINGS

Table No. 29

SHAFT TOLERANCES FOR TAPERED ROLLER BEARINGS	
Shaft Diameter (in.)	Shaft Tolerance (in.)
1 3/16 - 1 7/16	Plus .0000 to minus .0005
1 1/2 - 3	Plus .0000 to minus .0010
3 3/16 - 3 15/16	Plus .0000 to minus .0010
4 - 5	Plus .0000 to minus .0015

Table No. 30

BORE TOLERANCES FOR TAPERED ROLLER BEARINGS	
Shaft Diameter (in.)	Bore Tolerance (in.)
1 3/16 - 1 7/16	Plus .0010 to minus .0000
1 1/2 - 3	Plus .0010 to minus .0000
3 3/16 - 3 15/16	Plus .0020 to minus .0000
4 - 5	Plus .0020 to minus .0000

Table No. 31

SELF ALIGNING TAPERED ROLLER BEARING (RPB) CAP BOLT TORQUE TIGHTENING RECOMMENDATIONS (FT-LBS)					
Sizes	Pillow Block	Flange Block	PILOTED FLANGE		Expansion Pillow Block
			Outside Bolts	Inside Bolts	
1 3/16 - 1 1/4	17	31	17	4	17
1 3/8 - 1 7/16	31	31	17	4	31
1 1/2 - 1 11/16	31	31	17	4	31
1 3/4 - 2	31	31	17	4	31
2 3/16	31	75	49	8	31
2 1/4 - 2 1/2	75	75	49	8	75
2 11/16 - 3	75	75	49	8	75
3 3/16 - 3 1/2	266	150	75	17	266
3 15/16 - 4	266	150	75	17	150
4 7/16 - 4 1/2	266	-	150	75	150
4 15/16 - 5	394	-	150	75	266

### High Speed Applications

Applications where the speed is in the range of 80-100% of the maximum speeds listed in the rating tables on pages 180, 181 and 183, should be reviewed and given special consideration.

Modifications to consider include:

- Shaft size should be controlled to specifications listed in the installation section. See tables above.
- Skwezloc and double lock are the preferred lock systems for high speed applications.
- High quality lubricants should be used.
- Grease should be added more frequently and in small amounts. See Page 197.
- Care in mounting techniques should be exercised. See Page 200-205.

# SEALMASTER® SET SCREW & CAPSCREW INFORMATION

**Table No. 32 BALL BEARINGS**

STANDARD DUTY			MEDIUM DUTY		SETSCREW AND CAPSCREW INFORMATION							
SHAFT SIZE	INSERT #	ER #	SHAFT SIZE	INSERT #	SETSCREW LOCKING				SKWZLOC LOCKING			
					THREAD	HEX SIZE	TIGHTEN TO (IN.-LBS.)	TIGHTEN TO (FT.-LBS.)	THREAD	BORE SIZE	TIGHTEN TO (IN.-LBS.)	TIGHTEN TO (FT.-LBS.)
1/2 9/16 5/8 11/16 3/4 20mm	2-08 2-09 2-010 2-011 2-012 5204	ER-8 ER-9 ER-10 ER-11 ER-12 ER-204	-	-	1/4-28	1/8	66 - 85	5.5 - 7.2	8-32	T-25	63 - 70	5.3 - 5.8
13/16 7/8 15/16 25mm 1	2-013 2-014 2-015 5205 2-1	ER-14 ER-15 ER-205 ER-16	-	-	1/4-28	1/8	66 - 85	5.5 - 7.2	8-32	T-25	63 - 70	5.3 - 5.8
1 1/16 1 1/8 1 3/16 30mm 1 1/4R	2-11 2-12 2-13 5206 1-14	ER-17 ER-18 ER-19 ER-206	15/16 1 25mm	3-015 3-1 5305	1/4-28	1/8	66 - 85	5.5 - 7.2	8-32	T-25	63 - 70	5.3 - 5.8
1 1/4 1 5/16 1 3/8 35mm 1 7/16	2-14 2-15 2-16 5207 2-17	ER-20 ER-21 ER-22 ER-207 ER-23	1 3/16 30mm	3-13 5306	5/16-24	5/32	126 - 164	10.5 - 13.7	10-24	T-27	81 - 90	6.8 - 7.5
1 1/2 1 9/16 40mm	2-18 2-19 5208	ER-24 ER-25 ER-208	1 7/16 35mm	5307 3-17	5/16-24	5/32	126 - 164	10.5 - 13.7	10-24	T-27	81 - 90	6.8 - 7.5
1 5/8 1 11/16 1 3/4 45mm	2-110 2-111 2-112 5209	ER-26 ER-27 ER-28 ER-209	1 1/2 40mm	3-18 5308	5/16-24	5/32	126 - 164	10.5 - 13.7	10-24	T-27	81 - 90	6.8 - 7.5
1 13/16 1 7/8 1 15/16 50mm 2R	2-113 2-114 2-115 5210 1-2	ER-30 ER-31 ER-210	1 11/16 1 3/4 45mm	3-111 3-112 5309	3/8-24	3/16	228 - 296	19.0 - 24.7	1/4-20	T-30	162 - 180	13.5 - 15.0
2 2 1/8 55mm 2 3/16	2-2 2-22 5211 2-23	ER-32 ER-34 ER-211 ER-35	1 15/16 50mm	3-115 5310	3/8-24	3/16	228 - 296	19.0 - 24.7	1/4-20	T-30	162 - 180	13.5 - 15.0
2 1/4 2 5/16 60mm 2 3/8 2 7/16	2-24 2-25 5212 2-26 2-27	ER-36 ER-212 ER-38 ER-39	55mm 2 3/16	5311 3-23	3/8-24	3/16	228 - 296	19.0 - 24.7	1/4-20	T-45	360 - 400	30.0 - 33.3
2 1/2 2 11/16 70mm	2-211 5214	ER-40 ER-43 ER-214	2 7/16 2 1/2 65mm	3-27 3-28 5313	7/16-20	7/32	348 - 452	29.0 - 37.7	-	-	-	-
2 7/8 2 15/16 75mm	2-214 2-215 5215	ER-46 ER-47 ER-215	2 11/16 70mm	3-211 5314	7/16-20	7/32	348 - 452	29.0 - 37.7	-	-	-	-
3 80mm 3 3/16	5216 2-33	ER-48 ER-216 ER-51	2 15/16 75mm 3	3-215 5315 3-3	7/16-20	7/32	348 - 452	29.0 - 37.7	-	-	-	-
3 1/4 3 3/8 3 7/16	2-34 2-36 2-37	ER-52 ER-54 ER-55	80mm 3 3/16	5316 3-33	7/16-20	7/32	348 - 452	29.0 - 37.7	-	-	-	-
3 1/2 90mm	2-38 5218	-	3 7/16	3-37	1/2-20	1/4	504 - 655	42.0 - 54.6	-	-	-	-
3 15/16 4	-	ER-63 ER-64	100mm 3 15/16 4	5320 3-315 3-4	5/8-18	5/16	1104 - 1435	92.0 - 119.6	-	-	-	-
-	-	-	4 7/16 4 15/16	3-47 3-415	5/8-18	5/16	1104 - 1435	92.0 - 119.6	-	-	-	-

**Table No. 33 RPB ROLLER BEARINGS**

SETSCREW TIGHTENING TORQUE INFORMATION				
SHAFT SIZE (IN.)	THREAD	HEX SIZE	TIGHTEN TO (IN.-LBS.)	TIGHTEN TO (FT.-LBS.)
1 3/16 - 1 11/16	5/16 - 24	5/32	108 - 140	9 - 12
1 3/4 - 2 1/2	3/8 - 24	3/16	180 - 230	15 - 19
2 11/16 - 3 1/2	1/2 - 20	1/4	408 - 530	34 - 45
3 15/16 - 4	5/8 - 18	5/16	876 - 1000	73 - 95
4 7/16 - 4 15/16	3/4 - 16	3/8	1440 - 1850	120 - 150

BALL BEARINGS

Table No. 34

ER HOUSING DIMENSION RECOMMENDATIONS (INCHES)										
SHAFT SIZES	OUTSIDE DIA. OF CARTRIDGE		STATIONARY HOUSING				REVOLVING HOUSING			
	DIAMETERS		DIAMETERS		THEORETICAL FIT		DIAMETERS		THEORETICAL FIT	
	MAX.	MIN.	MAX.	MIN.	TIGHT	LOOSE	MAX.	MIN.	TIGHT	LOOSE
1/2 - 3/4	1.8506	1.8498	1.8508	1.8505	.0001	.0010	1.8503	1.8500	.0006	.0005
7/8 - 1	2.0474	2.0464	2.0474	2.0473	.0001	.0010	2.0469	2.0468	.0006	.0005
1 1/16 - 1 3/16	2.4413	2.4403	2.4413	2.4412	.0001	.0010	2.4408	2.4407	.0006	.0005
1 1/4 - 1 7/16	2.8348	2.8338	2.8348	2.8347	.0001	.0010	2.8343	2.8342	.0006	.0005
1 1/2 - 1 9/16	3.1498	3.1488	3.1498	3.1497	.0001	.0010	3.1493	3.1492	.0006	.0005
1 5/8 - 1 3/4	3.3466	3.3469	3.3469	3.3465	.0001	.0013	3.3463	3.3459	.0007	.0007
1 7/8 - 1 15/16	3.5434	3.5424	3.5437	3.5433	.0001	.0013	3.5431	3.5427	.0007	.0007
2 - 2 3/16	3.9371	3.9361	3.9374	3.9370	.0001	.0013	3.9368	3.9364	.0007	.0007
2 1/4 - 2 3/16	4.3308	4.3298	4.3311	4.3307	.0001	.0013	4.3305	4.3301	.0007	.0007
2 1/2 - 2 11/16	4.9214	4.9204	4.9220	4.9212	.0002	.0016	4.9213	4.9205	.0009	.0009
2 7/8 - 2 15/16	5.1181	5.1171	5.1187	5.1179	.0002	.0016	5.1180	5.1172	.0009	.0009
3 - 3 3/16	5.5119	5.5107	5.5123	5.5117	.0002	.0016	5.5116	5.5110	.0009	.0009
3 1/4 - 3 7/16	5.9056	5.9044	5.9060	5.9054	.0002	.0016	5.9053	5.9047	.0009	.0009
3 11/16 - 4	7.4806	7.4788	7.4812	7.4804	.0002	.0024	7.4802	7.4794	.0012	.0014

\* To install an ER Type bearing into a housing, push ONLY on outer ring to avoid damaging balls and races.

Table No. 35

SC HOUSING DIMENSION RECOMMENDATIONS (INCHES)							
SHAFT SIZES		OUTSIDE DIA. OF CARTRIDGE		STATIONARY HOUSING		REVOLVING HOUSING	
STANDARD DUTY	MEDIUM DUTY	DIAMETERS		DIAMETERS		DIAMETERS	
		MAX.	MIN.	MAX.	MIN.	MAX.	MIN.
1/2 - 11/16	-	2.6885	2.6865	2.6905	2.6885	2.6875	2.6855
3/4	-	2.9385	2.9365	2.9405	2.9385	2.9375	2.9355
13/16 - 1	-	3.1260	3.1240	3.1280	3.1260	3.1250	3.1230
1 1/16 - 1 1/4	15/16 - 1	3.5010	3.4990	3.5030	3.5010	3.5000	3.4980
1 1/4 - 1 7/16	1 3/16 - 1 1/4	3.8760	3.8740	3.8780	3.8760	3.8750	3.8730
1 1/2 - 1 9/16	1 7/16	4.1885	4.1865	4.1905	4.1885	4.1875	4.1855
1 5/8 - 1 3/4	1 1/2	4.3760	4.3740	4.3780	4.3760	4.3750	4.3730
1 13/16 - 2	1 11/16 - 1 3/4	4.5635	4.5615	4.5655	4.5635	4.5625	4.5605
2 - 2 3/16	1 15/16 - 2	4.9385	4.9365	4.9405	4.9385	4.9375	4.9355
2 1/4 - 2 7/16	2 3/16 - 2 1/4	5.8760	5.8740	5.8780	5.8760	5.8750	5.8730
2 1/2 - 2 11/16	2 7/16 - 2 1/2	6.2510	6.2490	6.2530	6.2510	6.2500	6.2480
2 7/8 - 2 15/16	2 11/16	6.6260	6.6240	6.6280	6.6260	6.6250	6.6230
-	2 15/16 - 3	7.0010	6.9990	7.0030	7.0010	7.0000	6.9980
-	3 3/16 - 3 1/4	7.4385	7.4365	7.4405	7.4385	7.4375	7.4355
-	3 7/16 - 3 1/2	8.1885	8.1865	8.1905	8.1885	8.1875	8.1855
-	3 15/16 - 4	9.5010	9.4990	9.5030	9.5010	9.5000	9.4980

\*Avoid excessive tightening of anchor bolts on SC casting.

ERCI Bearings - see page 119 for typical housing.

Refer to page 182 for relevant disclaimer.

### EMERSON POWER TRANSMISSION

*EPT MOUNTED BEARING DIVISION*

Mail To: Sealmaster Bearings - Application Engineering  
 1901 Bilter Rd.  
 Aurora IL 60507

Fax to: Application Engineering 630-898-6064

Distributor Information		Customer Information	
Distributor Name		Company Name	
Contact Name		Contact Name	
Street Address		Street Address	
City/State/Zip		City/State/Zip	
Phone		Phone	
Fax		Fax	
Internet E-Mail		Internet E-Mail	
Is the Customer an:                      OEM or End User		Industry	
Application Information			
Is this a new application		Yes or No	
Speed: (rpm)		EXPLAIN:                      Climate Conditions: Wet    ☐ Washdown                      ☐ Dry                                      ☐ Clean                                  ☐ Dirty                                  ☐ Chemicals                         ☐	
Service Life Required: (hours):			
Shaft Diameter:			
Load Information (lbs.):	Load Conditions: Steady    ☐	Operating Temperature (°F):	
Radial (lbs.):	Shock                                  ☐	Is the bearing in the elevated temp?                      Yes / No	
Axial / Thrust (lbs.):	Thrust                                  ☐	Is the heat coming through the shaft?                      Yes / No	
	Oscillation                          ☐		
If loads unknown attach detailed sketch***		Other                                  ☐	
Complete Application Description: Horsepower (bhp):		Motor	
		Driven Pulley Diameter (in.):	
		Distance Between Bearings:	

\*\*\*PLEASE ATTACH DETAILED SKETCH OF APPLICATION.  
 INCLUDE ALL DIMENSIONS AND SYSTEM LOAD LOCATIONS



	SET SCREW	SKWEZLOC	ROLLER	ROD END
AC/NT .....	132	132		
Aggregate .....	138	138	138	
AH .....			124-125	
Air Handling .....	132	132	124-125,132	
Application Calculations .....	184-186	184-186	184-186	
Application Worksheet .....				174-175
Applications .....	129	129	129	148
Back Side Sheild Assembly .....	86,136	136		
Backed Off Seal .....	188	188		
Ball Path Roundness .....	18, 191	67, 191		
Bearing Basics .....	192	192		
Bearing Function .....	192	192		
Beverage Bearings .....	86			
Black Oxide .....	18	18	100-102	
Bore Tolerances .....	204	204	204	See Dim. Chart
Cap Screw Specifcaiton .....		205		
Cartridges .....	33, 57	75, 81	118-120	
Cast Steel .....			102,112	
Clevis .....				148,165
Combined Load Calculations .....	178	178	182	
Computing Bearing Loads .....	185-186	185-186	185-186	148
Construction .....	134		134	
Contact Seal .....	188-189	188-189	188-189	
Corrosion Resistant Bearings .....	88-89		122-123	
Cylindrical Bearing Housing Recommendations .....	206	206	119	172
CR Duty Bearings .....	88-89		122-123	
Double Lock Set Screw .....	10, 12, 190		102	
Ductile Iron .....	187		103	
Eccentric Drives .....	140		140	
End Caps .....	86, 90			
Engineering .....	176	176	176	147
Engineering Table of Contents .....	177	177	177	147
Equivalent Load Calculation .....	178	178	182	
ER Housing Recommendations .....	206	206		
ER Style .....	41	75		
ERCI Housing Recommendations .....			119	
Expansion Inserts .....	42	76	118	
Featured Products .....	85-93		122-127	
Features .....	14-19	64-68	98-103	146
Felt Seal .....	14,18	14,18	100-101	
Flange Cartridges .....	29, 56	73, 81	113, 116-117	
Fluoropolymer Coating .....	86-89		122-123	
Flush Type Fitting .....				173
Four-Bolt Flanges .....	28, 55	72, 80	113-115	
Full Dog Set Screws .....	130			
Furnace Bearings .....	90			
Groove Lubrication .....				149
Half Dog Set Screws .....	130			
Hanger Bearings .....	30-31			
HeatGard Plus Seal .....	188	188		
HeatGard Seal .....	188	188		
HeatGard Ultra Seal .....	188	188		
High Temperature Bearings .....	130	130	130	
Housing Fits .....	193	193	103, 124-125	172
Housing Materials .....	187	187	187	
Housing Selection .....	187	187	187	
Installation Instructions .....	200-203	200-203	200-203	172
L10 Life .....	178	178	182	
Life Adjustment Factors .....	178	178		
Lock Selection .....	190	191	190	

	SET SCREW	SKWEZLOC	ROLLER	ROD END
Low Drag .....	188	188		
Lubrication and Care .....	196	196	196	149
Lubrication Fittings .....	198	198	198	173, 198
Medium Duty .....	46-62	79-84		
Metric-Skwez .....		85		
Mining .....	138		138	
Misalignment .....	17, 193	17, 193	100	148, 165
Mixers .....	142	142	142	
Noise Test .....	132	132		
Nomenclature .....	10-13	10-13	96-97	150
Nomex Seal .....	188	188	103	
Normal Duty .....	20-45	69-77		
Operating Temperatures .....	130	130	130	147
Paver Bearings .....	134	134		
Pictorial Index .....	10, 12	11, 13	96	
ProGard Seal .....	188	188		
Rating Tables .....	180	180	183	See Dim. Charts
Ratings and Selection .....	178	178	182	147
Reduced Clearance (RC) .....	138-142, 193	138-142, 193	138-142, 193	
Retainer .....	19	19	131	
Rod End Construction .....				146
Rubber Mounts .....	34, 35			
SafeGard Seal .....	188	188		
SC Housing Recommendations .....	206	206		
Seal Selection .....	188	188	188	
Seal Speed Tables .....	189	189	189	
Selection Guide .....	176	176	176	147
Set Screw Specifications .....	205	205	205	
Shaft Expansion Formula .....	90	90	90	90
Shaft Tolerances .....	204	204	204	
Shielded Ball Bearings .....	134, 138	134, 138		
Stainless Steel .....	86, 88, 136	88, 136	122, 136	173
Stamped Steel Units .....	34			
Stud Dimensions .....				164
Table of Contents .....	9	9	95	145
Take-Up Bearings .....	32, 58	74, 82		
Take-Up Frames .....	36-39	36-39		
Tapped Base .....	23	71		
Thin Dense Chrome .....	86, 136	136		
Three -Piece Rod Ends .....				146
Three Bolt Flange Brackets .....	27	74		
Tight Fit (TF) .....	140, 193	140, 193	103, 140, 193	
Torque Recommendations .....	204-205	204-205	205	
Two-Bolt Flanges .....	26, 34, 54	71, 72, 80		
Two-Piece Rod Ends .....				146
UltraGard Seal .....	188	188		
Vertical Mounting .....	142	142, 191	142	
Vibration Analysis .....	194	194	195	
Web Seal .....	188	188		
Wet Environments .....	136	136	136	
X Seal .....	188	188		
Yoke .....				148



	PAGE		PAGE
AR, Standard Duty .....	42	MSFPD .....	53
AR/AR-N .....	151	MSFT .....	54
AR-T, Standard Duty .....	76	MSFT-T .....	80
AR, Medium Duty .....	59	MSPD .....	52
AR-T, Medium Duty .....	83	MST .....	58
ARE/ARE-N .....	152	MST-T .....	82
ARE-20/ARE-20N .....	153	NP .....	20
BALL BEARING INSERTS		NP-C CR .....	92
Standard Duty-Single Lock .....	43	NPD .....	22
Standard Duty-Double Lock .....	44	NP-T .....	69
Standard Duty-Skwezloc .....	76	NPG .....	38-39
Medium Duty-Single Lock .....	60	NPL .....	21
Medium Duty-Double Lock .....	61	NPL-C CR .....	92
Medium Duty-Skwezloc .....	83	NPL-T .....	69
BF .....	93	RB .....	35
BFB .....	93	RCI .....	120
BFT .....	93	RCI-A .....	120
BH-LS .....	171	RCI-M .....	127
BP .....	92	RCIA-M .....	127
BPL .....	92	RFB .....	114
BST .....	93	RFB-A .....	115
BTB .....	92	RFP .....	116
BTS-LS .....	170	RFP-A .....	117
CFF/CFF-N .....	160	RPB .....	104
CFF-T .....	156	RPB-A .....	105
CFM/CFM-N .....	161	RPB-AH .....	124
CFM-T .....	157	RPB-CR .....	122
COM .....	168	RPB-M .....	126
COR .....	167	RPB-XT .....	110-111
CTFD .....	162	SBG/SBG-S/SBG-SS/SBG-SA .....	166
CTMD .....	163	SC .....	33
DRPB .....	107	SC-T .....	73
DRPB-A .....	108	SCHB .....	31
EMP .....	48	SEHB .....	30
EMP-T .....	79	SF .....	28
ER .....	41	SF-CCR .....	93
ERCI .....	118	SF-T .....	72
ER-T .....	75	SFC .....	29
ETXP .....	40	SFC-T .....	73
EDPB-A .....	109	SFT .....	26
ERP .....	106	SFT-C CR .....	93
ERP-XT .....	111	SFT-T .....	72
FB .....	27	SP .....	24
FB-C CR .....	93	SP-T .....	70
FB-T .....	74	SPB .....	112
FEC (End Cap) .....	92	SPD .....	25
FEO (End Cap) .....	92	SPG .....	39
FLBG .....	169	SPM .....	50
HEC (End Cap) .....	91	ST .....	32
HF .....	90-91	ST-C CR .....	93
HFC (End Cap) .....	91	ST-T .....	74
HFT .....	90-91	TB .....	23
MFC .....	56	TB-C CR .....	93
MFC-T .....	81	TB-T .....	71
MFP .....	51	TEC (End Cap) .....	92
MP .....	47	TEO (End Cap) .....	92
MP-T .....	79	TF/TF-N .....	158
MPD .....	49	TFT-T .....	71
MSC .....	57	TM/TM-N .....	159
MSC-T .....	81	TR/TR-N .....	154
MSF .....	55	TRE/TRE-N .....	155
MSF-T .....	80	TXP .....	40