

Bearings Catalog

Download the most up-to-date version
at www.rexnord.com/documentation



Rexnord Bearings Catalog

Section Index

	Page		Page
SPHERICAL ROLLER BEARINGS		BALL BEARINGS	
Units: Rex®	9	Standard Duty (200 Series)	
Features and Benefits	10	Units: Link-Belt	285
Nomenclature	14	Features and Benefits	286
Engineering	15	Nomenclature	288
Dimensions		Engineering	290
Pillow Blocks	29	Dimensions	
Flange Blocks	59	Pillow Blocks	299
Cartridge Blocks	81	Flange Blocks	321
Take-up Blocks	93	Take-up Blocks	359
Take-up Assemblies	101	Hanger Units	366
Duplex Units	121	Take-up Assemblies	369
Unmounted Replacement Bearings	123	Take-up Frames	373
Replacement Kits	129	Hanger and Trough Units	377
SHURLOK® Installation Tools	130	Unmounted Replacement Bearings	379
Units: Link-Belt®	131	Medium Duty (200 Series)	
Features and Benefits	132	Units: Link-Belt	399
Nomenclature	134	Features and Benefits	400
Engineering	135	Nomenclature	402
Dimensions		Engineering	404
Pillow Blocks	141	Dimensions	
Flange Blocks	159	Pillow Blocks	409
Cartridge Blocks	171	Flange Blocks	411
Take-up Blocks	177	Take-up Blocks	417
Take-up Assemblies	181	Hanger Units	419
Take-up Frames	183	Unmounted Replacement Bearings	421
Unmounted Replacement Bearings	185	Heavy Duty (300 Series)	
Replacement Kits	189	Units: Link-Belt	423
Units: Rexnord® PT Select Series	191	Features and Benefits	424
Features and Benefits	192	Nomenclature	425
Nomenclature	193	Engineering	426
Engineering	194	Dimensions	
Dimensions		Pillow Blocks	431
Pillow Blocks	198	Flange Blocks	436
Flange Blocks	201	Cartridge Blocks	442
Split Housings: Link-Belt	205	Take-up Blocks	445
Features and Benefits	206	Take-up Frames	447
Nomenclature	208	Unmounted Replacement Bearings	448
Engineering	210	SHURLOK Installation Tools	452
Dimensions		Units: Klean-Gard™ & Dura-Klean™	453
Pillow Blocks	224	Features and Benefits	454
Take-up Assemblies	241	Nomenclature	455
Replacement Parts	243	Engineering	456
Link-Belt	255	Dimensions	
Features and Benefits	256	Klean-Gard Pillow Blocks	459
Nomenclature	257	Klean-Gard Flange Blocks	460
Engineering	258	Dura-Klean Pillow Blocks	463
Dimensions		Dura-Klean Flange Blocks	465
Unmounted Bearings	274	Dura-Klean Take-up Blocks	468
Single-Row	282	Klean-Gard Accessory Kits	469
Double-Row	283	CYLINDRICAL ROLLER BEARINGS	
		Link-Belt	471
		Features and Benefits	472
		Nomenclature	473
		Engineering	474
		Dimensions	
		Single Row	491
		Double Row	499
		FILAMENT BEARINGS	
		Standard Sleeves: Rex RPT	501
		Features and Benefits	502
		Nomenclature	503
		Engineering	504
		Dimensions	
		Straight Sleeve	506
		Custom: Duralon®	513
		Features and Benefits	514
		Nomenclature	515
		Engineering	516
		Dimensions	
		Sleeve	517
		Annular	524
		Flange	525
		Thrust Washers	526
		Annular	527
		Mounting	528
		SLEEVE BEARINGS	
		Rigid: Link-Belt	531
		Features and Benefits	532
		Nomenclature	533
		Engineering	534
		Dimensions	
		Pillow Block	539
		Flange Blocks	545
		Take-up Assemblies	546
		Replacement Parts	547
		Flex Block: Link-Belt	551
		Features and Benefits	552
		Nomenclature	553
		Engineering	554
		Dimensions	
		Pillow Blocks	557
		Flange Blocks	558
		Take-up Frames	560
		ENGINEERING INFORMATION	
		Vibration Information	562
		Shaft Size Tolerance	564
		Setscrew Torque	565
		Bearing Selection	567

Quick Reference Tables

Rex Roller Bearings											
		Pillow Block	Page	Flange Units	Page	Piloted Flange Cartridge	Page	Steel Cartridge	Page	Cast Iron Cartridge	Page
SETScrew MOUNT	2000	ZA, ZAS, ZA-72, ZAS-72, ZEP, ZEPS	34 42 48	ZB, ZBS, ZEF	59	ZBR	74	ZCS	81	ZMC	86
	5000	ZAF, ZAFS, ZA, ZAS, ZA-72, ZAS-72, ZEP, ZEPS, ZP, ZPS	29 37 44 55 47	ZB, ZBS, ZF, ZFS, ZEF	62 65 71	ZBR	77	ZCS	83	ZMC	89
ECCENTRIC CAM MOUNT	3000	ZA, ZAS, ZA-72, ZAS-72, ZEP, ZEPS	36 43 54	ZB, ZBS, ZEF	61 70	ZBR	76	ZCS	82	ZMC	88
ADAPTER MOUNT	6000	ZAF, ZAFS, ZA, ZAS, ZA-72, ZAS-72, ZEP, ZEPS, ZP, ZPS	31 37 45 57 49	ZB, ZBS, ZF, ZFS, ZEF	63 67 72	ZBR	79	ZCS	84	ZMC	91
	9000	ZA, ZAS, ZA-72, ZAS-72, ZEP, ZEPS, ZP, ZPS	41 46 58 51	ZB, ZBS, ZF, ZFS, ZEF	64 68 73	ZBR	80	ZCS	85	ZMC	92

Rex Roller Bearings (continued)

		Take-up Block	Page	Take-up Frame Assemblies	Page	Duplex Units	Page	Replacement Inserts	Page
SETScrew MOUNT	2000	ZT	93	ZNT ZAT	109 116	ZD	121	2000U	123
	5000	ZT	93	ZHT ZST ZNT ZFT ZGT	101 107 112 118 119	ZD	122	5000U	126
ECCENTRIC CAM MOUNT	3000	ZT	95	ZNT ZAT	111 117			3000U	125
ADAPTER MOUNT	6000	ZT	95	ZHT ZNT	104 114			6000U	127
	9000	ZT	99					9000U	128

Quick Reference Tables

Link-Belt Roller Bearings													
		Pillow Block - 2 Bolt	Page	Pillow Block - 4 Bolt	Page	Flange Units	Page	Piloted Flange Cartridge	Page	Steel Cartridge	Page	Cast Iron Cartridge	Page
SETSCREW MOUNT	B22400	PB, PEB, PKB, PKEB, EPB, EPEB	141 147 153	PB, PEB, PKB, PKEB, EPB, EPEB	143 149 154	FB, FEB, EFRB, FBB	159 162 165	FCB	167	CSEB	171	CB	175
	B22500	PB, PEB, EPB, EPEB	144 155	PB, PEB, PKB, PKEB, EPB, EPEB	144 150 155	EFB	163			CSEB	173		
ADAPTER MOUNT	B22600	PB, PEB, PKB, PKEB, EPB, EPEB	145 151 156	PB, PEB, PKB, PKEB, EPB, EPEB	146 152 157	FB, FEB, EFB, FBB	161 164 166	FCB	169	CSEB	174	CB	176

Link-Belt Roller Bearings (continued)							
		Take-up Block	Page	Take-up Frame Assemblies	Page	Replacement Inserts	Page
SETSCREW MOUNT	B22400	TB ETB	177 179	DSB	181	B400L	185
	B22500			DSHB	182	B500L	187
ADAPTER MOUNT	B22600	TB	178			B600L	188

Quick Reference Tables

Link-Belt Ball Bearings

		Pillow Block	Page	Tapped Base	Page	Stamped Pillow Block	Page	2-Bolt Flange	Page	4-Bolt Flange	Page	3-Bolt Flange Bracket	Page	Piloted Flange Cartridge	Page
SETScrew MOUNT	S200	P3S PL3S	305 311	PT3S	314	PSS	318	FX3S	326	F3S	333	FB3S	335	FC3S	341
	U200	P3U PH3U PL3U	302 307 309	PT3U	313	PSU	316	FX3U	324	F3U	330	FB3U	334	FC3U	339
	MS200	MPS	410					MFXS	412	MFS	414			MFCS	416
	U300	PU, PEU P2U	433 434							FU, FEU	438			FCU, FCEU	441
ECCENTRIC CAM MOUNT	W200	P3W PL3W	304 310			PSW	317	FX3W	325	F3W	332				
	Y200	P3Y PH3Y PL3Y	301 306 308			PSY	315	FX3Y	323	F3Y	329			FC3Y	338
	Y300	PLY	435												
CONCENTRIC MOUNT	CL200	P3CL	299	PT3CL	312			FX3CL	321	F3CL	327			FC3CL	336
	MCL200	MPCL	409					MFCL	411	MFL	413			MFCCL	415
ADAPTER MOUNT	A300	PA, PEA	431							FA, FEA	436			FCA, FCEA	439
	U3K00	PU3K, PEU3K	432							FU3K, FEU3K	437			FCU3K, FCEU3K	440

Quick Reference Tables

Link-Belt Ball Bearings (continued)											
		2 & 3-Bolt Ductile Iron	Page	Take-up Blocks	Page	Hanger Bearings	Page	Take-up Assemblies	Page	Cartridge Bearing	Page
SETScrew MOUNT	S200			TH3S	365	CHBS EHB	366 367				
	U200	FXU, FXUG FXRU, FXRUG FU, FUG FRU, FRUG	343 346 349 352	T3U TH3U	360 364	HM3	377	TAS3 TDS3 NT3	369 370 372		
	MS200			MTHS	418	MCHBS MEHBS	419 420				
	U300			TU	446					CU, CEU	444
ECCENTRIC CAM MOUNT	W200	FXW, FXWG FXRW, FXRWG FW, FWG FRW, FRWG	344 347 350 353								
	Y200	FXY, FXYG FXRY, FXRYG FY, FYG FRY, FRYG	342 345 348 351	T3Y TH3Y	359 363						
	Y300										
CONCENTRIC MOUNT	CL200			TH3CL	361						
	MCL200			MTHCL	417						
ADAPTER MOUNT	A300			TA	445					CA, CEA	442
	U3K00									CU3K, CEU3K	443

Alphabetical Index

Series Number	Page	Series Number	Page	Series Number	Page
25 mm, 30 mm, 35 mm, 40 mm Bores	491	E		G	
25 mm thru 95 mm Bores	499	EFB	202	GMSA, GMSB	357
45 mm, 50 mm, 55 mm Bores	492	EFB22500	163	H	
60 mm, 65 mm, 70 mm Bores	493	EFB22600	164	Hex	394
75 mm, 80 mm, 85 mm Bores	494	EFRB22400	162	HM3U200	377
90 mm, 95 mm, 100 mm Bores	495	EHBS200	367	K	
105 mm, 110 mm, 120 mm Bores	496	EP2B	200	KLFBS200	462
130 mm, 140 mm, 150 mm Bores	497	EPB22400, EPEB22400	153	KLFSS200	461
160 mm, 170 mm, 180 mm, 190 mm, 200 mm Bores	498	EPB22400F, EPEB22400F	154	KLFXSS200	460
1000, 1000Z	539	EPB22500, EPEB22500, EPB22500F, EPEB22500F	155	KLPSS200	459
1100	540	EPB22600, EPEB22600	156	L	
2000U	123	EPB22600F, EPEB22600F	157	LC	373
3000U	125	ER	391	LC	560
3200F	559	ER-K	390	LHD FRAME	183
3200FX	558	ER-KCL	389	LHD FRAME	447
3200P	557	ETPB22400	179	M	
5000U	126	F		MCHBS200	419
6000U	127	F3CL200	327	MCLG200NLPA	421
9000U	128	F3S200	333	MEHBS200	420
21200, 21200Z	541	F3U200	330	MFCL200N	415
21300	542	F3W200	332	MFCL200N	413
21400, 21400Z, 2K1400Z	543	F3Y200	329	MFCS200N	416
21500, 21500Z	544	F2200, F2200Z	545	MFS200N	414
22200LB, 22200LBK	274	FA300, FEA300	436	MFCL200N	411
22300LB, 22300LBK	276	FB	201	MFXS200	412
23000LB, 23000LBK	278	FB3S200	335	MPCL200N	409
23100LB, 23100LBK	279	FB3U200	334	MPS200N	410
23200LB, 23200LBK	280	FB22400, FEB22400	159	MSG200NLPA	422
23900LB, 23900LBK	281	FB22600, FEB22600	161	MSL	392
A		FBB22400	165	MSLN	393
A20000	283	FBB22600	166	MS, MSC	356
A20000M	284	FC	203	MST	354
A20000S	282	FC3CL200N	336	MSTR	355
AG300L	448	FC3S200	341	MTHCL200N	417
B		FC3U200	339	MTHS200N	418
B400L	185	FC3Y200	338	N	
B500L	187	FCA300, FCEA300	439	NT3U200	372
B600L	188	FCB22400	167		
BPLB6800	228	FCB22600	169		
C		FCU3K00, FCEU3K00	440		
CA300, CEA300	442	FCU300, FCEU300	441		
CB22400	175	FF200	378		
CB22600	176	FRU200, FRUG200	352		
CHBS200	366	FRW200, FRWG200	353		
CLG200NL	379	FRY200, FRYG200	351		
CSEB22400	171	FU3K00, FEU3K00	437		
CSEB22500	173	FU200, FUG200	349		
CSEB22600	174	FU300, FEU300	438		
CU3K00, CEU3K00	443	FW200, FWG200	350		
CU300, CEU300	444	FX3CL200	321		
D		FX3S200	326		
DSB2800	546	FX3U200	324		
DSB22400	181	FX3W200	325		
DSHB22500	182	FX3Y200	323		
DSL6800	241	FXRU200, FXRUG200	346		
		FXRW200, FXRWG200	347		
		FXRY200, FXRYG200	345		
		FXU200, FXUG200	343		
		FXW200, FXWG200	344		
		FXY200, FXYG200	342		
		FY200, FYG200	348		

Series Number	Page
P	
P2B	198
P2U300	434
P3CL200N	299
P3S200	305
P3U200	302
P3W200	304
P3Y200	301
P4B	199
PA300, PEA300	431
PB22400F, PEB22400F	143
PB22400, PEB22400	141
PB22500, PEB22500, PB22500F, PEB22500F	144
PB22600F, PEB22600F	146
PB22600, PEB22600	145
PH3U200	307
PH3Y200	306
PKB22400F, PKEB22400F	149
PKB22400, PKEB22400	147
PKB22500F, PKEB22500F	150
PKB22600F, PKEB22600F	152
PKB22600, PKEB22600	151
PKLB6800FD8	231
PKLB6800F, PKLB6600F	229
PKLB7800F, PKLB7600F	234
PL3S200	311
PL3U200	309
PL3W200	310
PL3Y200	308
PLB6800D8, PLB6800FD8, PLB6600FD8	227
PLB6800, PLB6800F, PLB6600F	224
PLB6900, PLB6900F, SAF22600	232
PLB7800, PLB7800F, PLB7600F	233
PLB7900, PLB7900F, SAF22300	235
PLB23000K	236
PLB23100	238
PLB23100K	237
PLB23200	240
PLB23200K	239
PLY300	435
PPCL200	319
PPU200	320
PSS200	318
PSU200	316
PSW200	317
PSY200	315
PT3CL200N	312
PT3S200	314
PT3U200	313
PU3K00, PEU3K00	432
PU300, PEU300	433
R	
Round	395

Series Number	Page
S	
SG200ELPA	388
Square	397
T	
T3U200	360
T3Y200	359
TA300	445
TAS3U200	369
TB22400	177
TB22600	178
TDS3U200	370
TH3CL200	361
TH3S200	365
TH3U200	364
TH3Y200	363
TP, TPT, TSP, TSPT	374
TQP	375
TU300	446
U	
U200, UB200	383
UG3K00L	449
UG200, UBG200	384
UG300L	450
W	
W200, WB200	386
WF3S200	466
WFB3S200	467
WFX3S200	465
WG200, WBG200	387
WP3S200	463
WPT3S200	464
WTH3S200	468
Y	
Y200, YB200	381
YG200, YBG200	382
YG300	451
Z	
ZA2000-72, ZAS2000-72	42
ZA2000, ZAS2000	34
ZA3000-72, ZAS3000-72	43
ZA3000, ZAS3000	36
ZA5000-72, ZAS5000-72	44
ZA5000, ZAS5000	37
ZA6000-72, ZAS6000-72	45
ZA6000, ZAS6000	39
ZA9000-72, ZAS9000-72	46
ZA9000, ZAS9000	41
ZAF5000, ZAFS5000	29
ZAF6000, ZAFS6000	31
ZAT2000	116
ZAT3000	117

Series Number	Page
ZB2000, ZBS2000	59
ZB3000, ZBS3000	61
ZB5000, ZBS5000	62
ZB6000, ZBS6000	63
ZB9000, ZBS9000	64
ZBR2000	74
ZBR3000	76
ZBR5000	77
ZBR6000	79
ZBR9000	80
ZCS2000	81
ZCS3000	82
ZCS5000	83
ZCS6000	84
ZCS9000	85
ZD2000	121
ZD5000	122
ZEF2000	69
ZEF3000	70
ZEF5000	71
ZEF6000	72
ZEF9000	73
ZEP2000, ZEPS2000	52
ZEP3000, ZEPS3000	54
ZEP5000, ZEPS5000	55
ZEP6000, ZEPS6000	57
ZEP9000, ZEPS9000	58
ZF5000, ZFS5000	65
ZF6000, ZFS6000	67
ZF9000, ZFS9000	68
ZFT5000	118
ZGT5000	119
ZHT5000	101
ZHT6000	104
ZLF6000	33
ZMC2000	86
ZMC3000	88
ZMC5000	89
ZMC6000	91
ZMC9000	92
ZNT2000	109
ZNT3000	111
ZNT5000	112
ZNT6000	114
ZP5000, ZPS5000	47
ZP6000, ZPS6000	49
ZP9000, ZPS9000	51
ZST5000	107
ZT2000	93
ZT3000	95
ZT5000	96
ZT6000	98
ZT9000	99

Spherical Roller Bearings

Units: Rex



Contents

	Page
Features and Benefits	10
Nomenclature	14
Engineering	15
Dimensions	
Pillow Blocks	29
Flange Blocks	59
Cartridge Blocks	81
Take-up Blocks	93
Take-up Assemblies	101
Duplex Units	121
Unmounted Replacement Bearings	123
Replacement Kits	129
SHURLOK Installation Tools	130

Industries Served

Mining
Forest Products
Aggregates
Steel
Air Handling
Construction
Package Handling



Rex Spherical Roller Bearings



Easy Bearing Clearance Adjustment

Can be field adjusted to meet application needs.

Replaceable Bearing

Available in single set collar, double set collar, eccentric lock and adapter mounting to suit load and installation requirements.

Shaft Ready

Pre-lubricated with our standard grease for normal operation; other lubricants available for special conditions.

Super-finished Raceways

Super-finished raceways provide a cool running, quiet, high-speed and high-load capacity bearing.

Rugged Housing

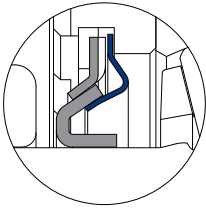
Standard material — cast iron. Steel or ductile iron available on request.

Multiple Housing Styles

Providing mounting features to match the operational and structural requirements.

Interchangeable Seals – Seal Types

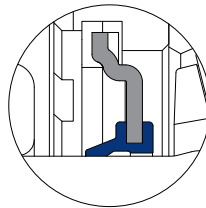
Type Z Seal Clearance



Denoted with a "Z" prefix in the model number. The standard seal used in the majority of applications.

- No frictional drag — generates no heat
- No speed limitations
- All metal — no temperature limitations

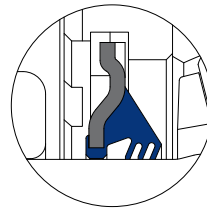
Type K Seal Light Contact



Substitute prefix "K" for "Z" in model number. Molded nitrile rubber lip seals out contaminants.

- Protects against contaminants
- Handles high speeds and vibration
- Less drag and heat generation than heavy contact seals

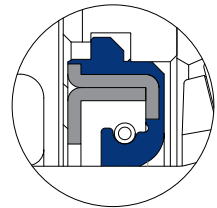
Type G Triple Lip Seal



Substitute prefix "G" for "Z" in model number. Premium elastomer, heavy duty contact, triple lip seal.

- Protects against fine particles and moisture
- Three contacting lips provide constant contact even during misalignment
- Metal outboard guard protects inner seal lips from abrasion and damage

Type M Seal Heavy Contact



Substitute prefix "M" for "Z" in model number. Premium elastomer, spring loaded contact lip.

- Protects against liquids and grit
- Spring loaded lip assures constant contact, even during misalignment
- Molded-in garter spring retains seal in housing
- Seals in lubricant on horizontal and vertical shafts
- Available in Viton® material

Auxiliary Cap Seals

- Recommended for severe environments
- Provide supplemental protection for the primary seal
- Seals against liquids and gritty contaminants. Particularly effective against water washdown, taconite, cement, sand or caking build-up
- Provides safety, encloses rotating mounting hardware
- Protects primary seal from physical damage
- May be filled with grease to provide purging action
- Available as open or closed end cap

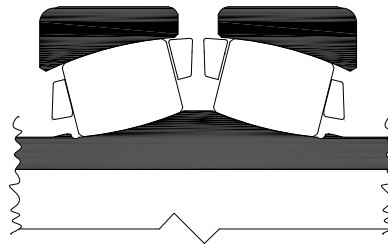


- Use "CB" Suffix in model number
- Protects from rotating shaft exposure and Foreign material penetration

Integral Self-Alignment

Our bearings represent the continuation of 80 years of bearing technology and experience. This design allows the inner race to misalign freely in any direction up to 4° of total misalignment.

By design, these bearings accept both radial and thrust loads under static, oscillatory, or dynamic conditions. The load is taken on the roller raceways, not the roller ends. This means that when thrust is loaded up to their allowable limit, **the bearings do not exhibit roller end wear.**



Featuring SHURLOK Adapter Mounts – Taking the Mystery Out of Mounting

Auxiliary end caps and four field interchangeable seal options ensure long bearing life through a full range of applications.

Self-aligning spherical roller bearing provides a total of 4° static and dynamic misalignment.

Super-finished raceways provide a cool running, quiet, high-speed and high-load capacity bearing

Roller elements are precision ground and super-finished to provide longer bearing life



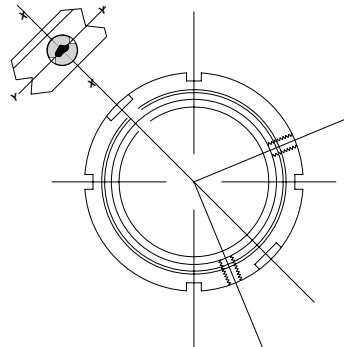
Adapter sleeve assembly allows easy installation/removal, plus enables use of commercial grade shafts

Positive Locking System allows minimal vibration during operation, therefore not requiring scheduled inspections for snugness of mountings

Spyglass™ Optical Strain Sensor (OSS) Technology reduces installation errors by changing color when tight



Positive Locking System



Mounting lockout utilizing Spyglass OSS

Not Installed



Installed



Easy Installation: Simply tighten the locknut until the Spyglass shows proper indication

6000 Series SHURLOK Roller Bearings are Also Available with These Housings



Pillow Block



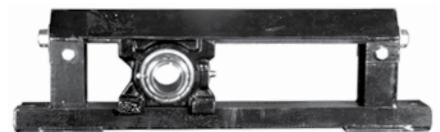
Flanged Units



Flanged Cartridge



Take-up Units



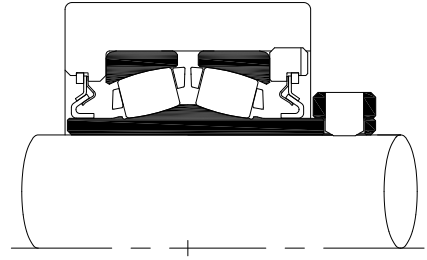
Take-up Assemblies

Shaft Mounting Styles

The following five mounting styles are available in any housing style.

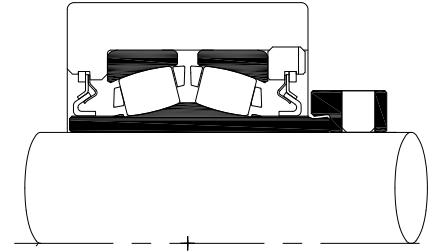
2000 Series Single Set Collar

- Normal duty
- Simplest installation
- Most economical



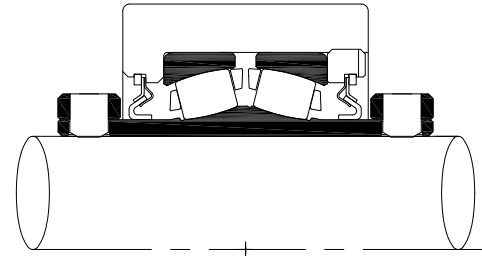
3000 Series Twist Lock™ Eccentric Locking Collar

- Medium duty
- Additional shaft holding power
- Accommodates undersized shafting
- Economical



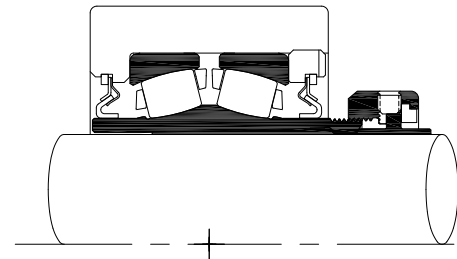
5000 Series Double Set Collar

- Heavy duty
- Increased shaft holding power and stability
- Moderate cost



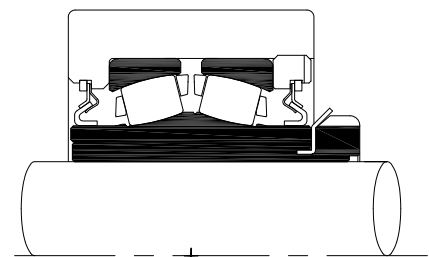
6000 Series SHURLOK Adapter Mount

- Heavy duty
- Spyglass Optical Strain Sensor (OSS) Technology
- Full bore contact for maximum shaft holding power, concentricity and running accuracy
- Accommodates undersized shafting
- Easily removable



9000 Series Adapter Mount

- Extra heavy duty
- Full bore contact for maximum shaft holding power, concentricity and running accuracy
- Accommodates undersized shafting



Nomenclature

Symbol

Description

A	Two open auxiliary end caps
AB	One open auxiliary end cap on locknut side, one closed on housing side
B	Two auxiliary end caps (open on housing side, closed on threaded cover side)
BA	One open auxiliary end cap on housing side, one closed on locknut side
X	Designates "SPECIAL UNITS", contact Rexnord Industries

Z	Clearance seal
K	Light contact seal
M	Heavy contact seal
G	Triple Lip Seal

A	Pillow block, fixed
AS	Pillow block, floating
AF	Pillow block, fixed SAF interchange
AFS	Pillow block, floating SAF interchange
LF	Split pillow block, fixed SAF interchange
LFS	Split pillow block, floating SAF interchange
P	Pillow block, fixed
PS	Pillow block, floating
EP	Pillow block, fixed Type E interchange
EPS	Pillow block, floating Type E interchange
B	Flanged block, fixed 4-bolt
BS	Flanged block, floating 4-bolt
EF	Flanged block, fixed 4-bolt Type E interchange
F	Flanged block, fixed 4 or 6-bolt
FS	Flanged block, floating 4 or 6-bolt
BR	Flanged cartridge block, fixed 4-bolt round
CS	Cartridge block, steel housing
MC	Cartridge block, cast iron housing
D	Duplex unit
N	Take-up block for protected screw frame
T	Take-up block for center pull frame
AT	Center pull take-up assembly
NT	Protected screw take-up assembly
HT	Center pull take-up assembly
FT	Elevator boot end take-up assembly
GT	Elevator head end take-up assembly
ST	Center pull spring loaded take-up assembly

11 Size code – only for take-up blocks and assemblies

2	2000 Series, single set collar
3	3000 Series, eccentric locking collar
5	5000 Series, double set collar
6	6000 Series, SHURLOK tapered adapter sleeve
9	9000 Series, tapered adapter sleeve

207	2 7/16" – last two digits in 16 th of an inch
100MM	100 millimeters

24	Inches of take-up adjustment – only for take-up assemblies
A	One open auxiliary end cap (threaded cover side)
B	One closed auxiliary end cap (threaded cover side)
C	Closed end cap housing side
CB	Closed end cap collar side
F	4-bolt housing (pillow blocks only)
G	Face locked threaded cover
H	Reverse assembly
PL	Precision bore diameter and bore roundness
R	Tight fit of outer races in housing (high vibration, shock loading)
S	Machined pilot on face of flanged units
V	Viton seal material (when M seal suffix is used)
Y	Redesigned shaft size – not interchangeable
04	C5 internal clearance (high temperature)
05	C4 internal clearance (high speed)
06	C0 internal clearance
07	C2 internal clearance
40	Preservative only, no lubrication in unit
42	Grease designation for Chevron SRI #2
43	Grease designation for Mobilith SHC460
63	Grease designation for Mobilith SHC100
66	Housing drilled both sides for aux caps
72	Steel housing
78	Steel retainers
82	Inner race with Rexlon lined bore - Teflon™ material

A Z A - 2 207 F

▼ Teflon™ is a trademark of The Chemours Company FC, LLC used under license by Toray Fluorofibers (America), Inc.

Seal Rating Guide

Application Conditions	Seal Ratings					
	Clearance	Light Contact	Heavy Contact	Viton	Triple Lip	Auxiliary Cap Consideration
	Z	K	M	M	G	
Shaft position						
Horizontal Shaft	4	4	4	4	4	
Vertical Shaft	1	3	4	4	4	
Operating Temperature						
Below -40°F	4	1	1	2	1	
-40°F to 0°F	4	3	3	4	3	
0°F to +250°F	4	4	4	4	4	
+250°F to +400°F	4	0	0	4	0	
Over 400°F	4	0	0	0	0	
Speed						
Equal to / Less than limit below	4	4	4	4	4	
More than limit below	4	1	1	1	1	
Vibration/Shock						
Occasional - Mild	3	4	4	4	4	
Occasional - Severe	2	4	4	4	4	
Continuous - Mild	1	4	3	3	3	
Continuous - Severe	0	4	3	3	3	
Abrasive Material						
Coarse - Over #10 Mesh	4	4	4	4	4	X
Small - #10 to #50 Mesh	3	4	4	4	4	X
Fine - #50 to #200 Mesh	1	3	4	4	4	X
Very fine - Under #200 Mesh	0	3	4	4	4	X
“Caking or buildup” (cement, etc.)	2	4	4	4	4	X
Moisture						
Splash	2	3	4	4	4	X
Rain	2	3	4	4	4	X
Saturated Atmosphere	1	3	4	4	4	X
Flooding	0	1	3	3	4	X
Pressure Wash	0	1	4	4	4	X
Fibrous Material						
Short Fibers (lint, etc.)	1	3	4	4	4	X
Long Fibers (grass, etc.)	1	3	4	4	4	X
Chemical						
Acid Fumes and Liquids	1	1	1	4	1	X
Alkaline Fumes and Liquids	1	1	1	4	1	X

To extend life in tough applications, our application experience indicates that special consideration should be given to the addition of Auxiliary Cap Seals in the areas shaded with and “X” on the chart.

Rating Code

- 4 - Excellent - Best seal for conditions listed.
- 3 - Good - Sealability is above average.
- 2 - Fair - Seal performs under intermittent conditions.
- 1 - Limited - Actual conditions must be known to evaluate sealability. Contact Rexnord for special assistance in the realm of materials and designs.
- 0 - Not acceptable - Will not effectively perform seal functions. Contact Rexnord for special assistance in the realm of materials and designs.

Seal Selection Guide

The choice of the seal for a mounted bearing is often the key to successful bearing operation and long service life. The SEAL SELECTION GUIDE incorporates years of Rexnord’s experience against the wide variety of conditions encountered on actual applications. Following the simple selection procedure outlined can translate the benefits of that broad experience to the individual applications through the choice of the most effective seal.

How to Use the Selection Guide

- The appropriate seal for a given application may be selected by comparing the job application conditions against those listed in the Seal Rating Guide on this page.
- When more than one application condition is present, the most appropriate seal may be selected based on prime sealing for the most detrimental condition, and secondary consideration given to the other application conditions.
- Addition of auxiliary caps will enhance the primary seal performance shown in the chart.

Considerations in Addition to Seal Selection

Under certain adverse conditions, other changes should be considered to achieve maximum bearing life:

- High temperature lubricants where housing or ambient temperatures exceed +200°F,
- Special greases for additional bearing protection where excessive water, solvents or chemicals are present.
- EP (extreme pressure) greases where high load, high shock load, or continuous vibration is present.
- Readjustment of internal operating clearance of bearing where extreme high or low temperature conditions exist.

Seal Speed Limit Table*

Size Code	2	3	4	5	6	7	8	9	10	11	12	13	14	15	16
Bearing Number	2000	2012	2102	2107	2111	2115	2203	2206	2211	2303	2311				
		2012	2103	2108	2112	2200	2204	2207	2212	2307	2315				
	2100	2104					2208	2215	2308	2400					
	3000			3107	3111	3115	3203	3207	3211	3307	3315				
								3208	3215	3308					
5000			5107	5108	5115	5200	5207	5208	5303	5311	5403Y	5415	5507	5515	5607
				5111		5203		5215	5307	5315	5407Y	5500	5600	5615	5700
6000			6107	6111	6115	6203	6206	6211	6303	6311	6403Y	6415	6507	6515	6607
							6207	6212	6307	6315	6407Y			6615	
9000						9115	9203	9207	9211	9303	9311Y	9403	9415	9503	9515
						9200		9208	9215	9307	9315Y	9407	9500	9507	9600
(RPM)	Z	6500	5750	5250	4450	4050	3650	3300	2800	2400	2050	1850	1600	1000	900
	K	4500	4000	3600	3100	2800	2500	2300	1900	1700	1400	N/A	N/A	N/A	N/A
	M	4400	3700	3300	2800	2500	2200	2000	1700	1400	1200	1100	1000	900	800
	G	N/A	2375	2175	1850	1675	1500	1350	1150	1000	850	775	650	N/A	N/A
Size Code	2	3	4	5	6	7	8	9	10	11	12	13	14	15	16

Refer to Seal Rating Guide shown above for speeds in excess of those listed in this table.

*Actual bearing speed limits are largely based upon the applied load and can be found on the Load Rating Table.

Selection Guide

To select a bearing, determine the applied radial load, the applied thrust load, the desired Rating Life, and applicable operating conditions. The procedure shown here will aid in selecting a bearing to meet an L_{10} design life. The formulas for calculating life expectancy should be used to determine the Rating Life L_{10} for the bearing selected.

The selection procedures and rating formulas shown here are in agreement with The American Bearing Manufacturers Association Standards and ANSI/ABMA STD 9-1990. Ratings are based on fatigue life. The Rating Life L_{10} or fatigue life at 90% reliability is the usual basis for bearing selection.

To assure a satisfactory bearing application, fitting practice, mounting, lubrication, sealing, static rating, housing strength, operating conditions and maintenance must be considered.

Steps for Selection

Step 1

Determine an appropriate L_{10} design life.

Type of service	Operating time, hours per year	Design life, years	L_{10} design life, hours
Light seasonal usage	500 to 750	3-5	3,000
Heavy seasonal usage	1,400 to 1,600	4-6	8,000
Industrial—8 hour shift	2,000	10	20,000
Industrial—16 hour shift	4,000	10	40,000
Industrial—continuous	8,700	10	80,000 to 100,000

Step 2

Determine a required $\left(\frac{C}{P}\right)$ from Table 1.

Step 3

Calculate the required C and select a roller bearing.

a For radial load only:

$$P = F_r$$

$$\text{required } C = \left(\frac{C}{P}\right) P \text{ using } \left(\frac{C}{P}\right) \text{ from Step 2}$$

Select a roller bearing from Table 2 with a basic load rating C equal to or greater than the required C.

Step 3 (continued)

b For combined radial and thrust loads:

Select a trial roller bearing of the desired shaft size from Table 2.

Calculate the ratio of thrust load F_a to the radial load F_r .

$$\frac{F_a}{F_r}$$

Calculate the equivalent radial load P

$$P = X F_r + Y F_a$$

If $\frac{F_a}{F_r}$ is equal to or less than e, then $P = X1 F_r + Y1 F_a$

If $\frac{F_a}{F_r}$ is greater than e, then $P = X2 F_r + Y2 F_a$

For values of e, X1, Y1, X2, and Y2, see Table 2.

Calculate the required C

$$\text{required } C = \left(\frac{C}{P}\right) P \text{ using } \left(\frac{C}{P}\right) \text{ from Step 2.}$$

Consult Table 2, basic load rating. If a smaller bearing meets, or nearly meets, the required C, its life expectancy can be calculated.

Note: If the load P is greater than .25C, consult Rexnord Bearing Division.

Selection

Symbols for formulas:

C = basic load rating, pounds (or newtons)

Co = static load rating, pounds (or newtons)

e = a reference value

Fa = thrust load, pounds (or newtons)

Fr = radial load, pounds (or newtons)

L10 = rating life, hours

n = speed, revolutions per minute

P = equivalent radial load, pounds (or newtons)

X = radial factor

Y = thrust factor

Table 1 • Relation of L10 life and speed to $\left(\frac{C}{P}\right)$

Bearing Life Hours L10	Speed, n									
	50	100	200	300	400	500	600	700	800	
3000	1.93	2.38	2.93	3.31	3.61	3.86	4.07	4.27	4.44	
4000	2.11	2.59	3.19	3.61	3.93	4.20	4.44	4.65	4.84	
5000	2.25	2.77	3.42	3.86	4.20	4.50	4.75	4.97	5.18	
6000	2.38	2.93	3.61	4.07	4.44	4.75	5.02	5.25	5.47	
8000	2.59	3.19	3.93	4.44	4.84	5.18	5.47	5.73	5.96	
10000	2.77	3.42	4.20	4.75	5.18	5.54	5.85	6.12	6.37	
12000	2.93	3.61	4.44	5.02	5.47	5.85	6.18	6.47	6.73	
14000	3.07	3.78	4.65	5.25	5.73	6.12	6.47	6.77	7.05	
16000	3.19	3.93	4.84	5.47	5.96	6.37	6.73	7.05	7.34	
18000	3.31	4.07	5.02	5.66	6.18	6.60	6.97	7.30	7.60	
20000	3.42	4.20	5.18	5.85	6.37	6.81	7.20	7.54	7.85	
25000	3.65	4.50	5.54	6.25	6.81	7.29	7.70	8.06	8.39	
30000	3.86	4.75	5.85	6.60	7.20	7.70	8.13	8.51	8.86	
35000	4.04	4.97	6.12	6.92	7.54	8.06	8.51	8.92	9.28	
40000	4.20	5.18	6.37	7.20	7.85	8.39	8.86	9.28	9.66	
45000	4.36	5.36	6.60	7.46	8.13	8.69	9.18	9.61	10.00	
50000	4.50	5.54	6.81	7.70	8.39	8.97	9.48	9.92	10.30	
60000	4.75	5.85	7.20	8.13	8.86	9.48	10.00	10.50	10.90	
70000	4.97	6.12	7.54	8.51	9.28	9.92	10.50	11.00	11.40	
80000	5.18	6.37	7.85	8.86	9.66	10.30	10.90	11.40	11.90	
90000	5.36	6.60	8.13	9.18	10.00	10.70	11.30	11.80	12.30	
100000	5.54	6.81	8.39	9.48	10.30	11.00	11.70	12.20	12.70	
150000	6.25	7.70	9.48	10.70	11.70	12.50	13.20	13.80	14.40	
200000	6.81	8.39	10.30	11.70	12.70	13.60	14.40	15.00	15.70	
	Speed, n									
	900	1000	1200	1500	1800	2400	3000	3600	6000	
3000	4.60	4.75	5.02	5.36	5.66	6.18	6.60	6.97	8.13	
4000	5.02	5.18	5.47	5.85	6.18	6.73	7.20	7.60	8.86	
5000	5.36	5.54	5.85	6.25	6.60	7.20	7.70	8.13	9.48	
6000	5.66	5.85	6.18	6.60	6.97	7.60	8.13	8.59	10.00	
8000	6.18	6.37	6.73	7.20	7.60	8.29	8.86	9.36	10.90	
10000	6.60	6.81	7.20	7.70	8.13	8.86	9.48	10.00	11.70	
12000	6.97	7.20	7.60	8.13	8.59	9.36	10.00	10.60	12.30	
14000	7.30	7.54	7.96	8.51	8.99	9.80	10.50	11.10	12.90	
16000	7.60	7.85	8.29	8.86	9.36	10.20	10.90	11.50	13.40	
18000	7.88	8.13	8.59	9.18	9.70	10.60	11.30	11.90	13.90	
20000	8.13	8.39	8.86	9.48	10.00	10.90	11.70	12.30	14.40	
25000	8.69	8.97	9.48	10.10	10.70	11.70	12.50	13.20	15.40	
30000	9.18	9.48	10.00	10.70	11.30	12.30	13.20	13.90	16.20	
35000	9.61	9.92	10.50	11.20	11.80	12.90	13.80	14.60	17.00	
40000	10.00	10.30	10.90	11.70	12.30	13.40	14.40	15.20	17.70	
45000	10.40	10.70	11.30	12.10	12.80	13.90	14.90	15.70	18.30	
50000	10.70	11.00	11.70	12.50	13.20	14.40	15.40	16.20	18.90	
60000	11.30	11.70	12.30	13.20	13.90	15.20	16.20	17.10	20.00	
70000	11.80	12.20	12.90	13.80	14.60	15.90	17.00	17.90	20.90	
80000	12.30	12.70	13.40	14.40	15.20	16.50	17.70	18.70	21.80	
90000	12.80	13.20	13.90	14.90	15.70	17.10	18.30	19.40	22.60	
100000	13.20	13.60	14.40	15.40	16.20	17.70	18.90	20.00	23.30	
150000	14.90	15.40	16.20	17.30	18.30	20.00	21.40	22.60	26.30	
200000	16.20	16.70	17.70	18.90	20.00	21.80	23.30	24.60	28.70	

Basic Formula

$$\left(\frac{C}{P}\right) = \left(\frac{L_{10} \times n \times 60}{1,000,000}\right)^{3/10}$$

$$L_{10} = \frac{\left(\frac{C}{P}\right)^{10/3} \times 1,000,000}{n \times 60}$$

Life Expectancy

To calculate the Rating Life L10 of any selected or trial bearing:

Step 1

Determine the equivalent radial load P.

a For radial load only:

$$P = Fr$$

b For combined radial and thrust load:

$$P = XFr + YFa$$

if $\frac{Fa}{Fr}$ is equal to or less than e, then

$$P = X1Fr + Y1Fa$$

if $\frac{Fa}{Fr}$ is greater than e, then

$$P = X2Fr + Y2Fa$$

For values of e, X1, Y1, X2, and Y2, consult the appropriate bearing rating Table 2.

Step 2

Calculate the ratio of the basic load rating C to the equivalent radial load.

$$\left(\frac{C}{P}\right)$$

Step 3

Approximate the bearing life from Table 1.

Life Adjustment

The Rating Life, L10, may be modified for some applications in accordance with the formula

$$Ln = a1a2a3L10$$

where Ln = Adjusted life for (100-n) % reliability,

a1 = Life adjustment factor for reliability

a2 = Life adjustment factor

for material and processing

a3 = Life adjustment factor for operating conditions.

For most normal applications, all factors will be taken as 1, and the Rating Life used as the selection basis or life estimate. In addition, as long as standard catalog bearings are used, a2 will be normally set equal to one.

The factor a3 covers such things as lubrication, misalignment, and temperature. Some conditions that could yield a3 significantly different than unity include speeds less than 20000 DN or greater than 200000 DN, temperatures below -40°F (-40°C) or above 275°F (135°C). For other possible conditions, as well as additional information on life adjustment factors, consult Rexnord Bearing Division.

Table 2 • Load Ratings and Speed Limits

Size Code	Co Static load rating		C Basic load rating*		Approximate speed limit RPM				e	Fa Fr ≤ e		Fa Fr > e	
	newtons	pounds	newtons	pounds	Z seal	K seal	M seal	G seal		X1	Y1	X2	Y2
2	66279	14900	68147	15,320	6500	4500	4400	-	0.51	1.00	1.32	0.67	1.96
3	81402	18300	83849	18,850	5750	4000	3700	2375	0.48	1.00	1.40	0.67	2.09
4	92968	20900	88342	19,860	5250	3600	3300	2175	0.44	1.00	1.54	0.67	2.29
5	127664	28700	123750	27,820	4450	3100	2800	1850	0.45	1.00	1.51	0.67	2.24
6	147681	33200	128509	28,890	4050	2800	2500	1675	0.40	1.00	1.68	0.67	2.50
7	197501	44400	161782	36,370	3650	2500	2200	1500	0.40	1.00	1.68	0.67	2.50
8	237980	53500	192341	43,240	3300	2300	2000	1350	0.38	1.00	1.80	0.67	2.68
9	318048	71500	256885	57,750	2800	1900	1700	1150	0.38	1.00	1.79	0.67	2.66
10	403454	90700	375119	84,330	2400	1700	1400	1000	0.38	1.00	1.77	0.67	2.63
11	609406	137000	582584	130,970	2050	1400	1200	850	0.36	1.00	1.88	0.67	2.80
12	708602	159300	665009	149,500	1850	-	1100	775	0.33	1.00	2.02	0.67	3.00
13	1076025	241900	850055	191,100	1600	-	1000	650	0.37	1.00	1.81	0.67	2.70
14	1219258	274100	1021401	229,620	1000	-	900	-	0.38	1.00	1.78	0.67	2.66
15	1354928	304600	1104049	248,200	900	-	800	-	0.35	1.00	1.93	0.67	2.87
16	1759272	395500	1378326	309,860	800	-	700	-	0.33	1.00	2.07	0.67	3.09

*Values in table represent the 9000 and 6000 series bearings. When commercial grade shafting and clearance mounting are used, the table values should be reduced up to 5% for the 5000 series, 10% reduction for 3000 and reduced up to 15% for the 2000 series.

Adjustment Table

Size Code	Shaft Size (Inches)			Standard Factory Adjustment (Average Speed and Temperature)			Recommended Adjustment High Speeds				Clearance Adjustment Inches Per 15 Degrees	
	2000 Series	3000 Series	5000 Series	Standard Degrees Adjust	Standard Radial Clearance	Standard Axial Clearance	Speed Over	High Speed Degrees Adjust.	High Speed Radial Clearance	High Speed Axial Clearance	Radial	Axial
2	3/4 - 1	-	-	45	.0022-.0028	.0068-.0086	2000	55	.0028-.0034	.0086-.0105	0.001	0.003
3	1 1/8-1 1/4	-	-	50	.0024-.0030	.0078-.0098	2000	60	.0030-.0036	.0098-.0117	0.001	0.003
4	1 7/16-1 1/2	1 7/16	1 7/16	55	.0025-.0031	.0088-.0109	2000	65	.0031-.0037	.0110-.0130	0.001	0.003
5	1 11/16-1 3/4	1 11/16	1 1/2- 1 11/16	60	.0029-.0037	.0101-.0128	1500	70	.0037-.0045	.0128-.0156	0.001	0.003
6	1 15/16-2	1 15/16	1 15/16	85	.0033-.0041	.0127-.0157	1500	105	.0041-.0049	.0157-.0188	0.001	0.003
7	2 3/16-2 1/4	2 3/16	2-2 3/16	60	.0031-.0039	.0119-.0149	1250	75	.0039-.0047	.0150-.0180	0.001	0.003
8	2 3/8-2 1/2	2 7/16	2 7/16	65	.0032-.0040	.0131-.0163	1250	80	.0040-.0048	.0163-.0196	0.001	0.003
9	2 11/16-3	2 11/16-2 15/16	2 1/2-2 15/16	80	.0040-.0052	.0163-.0211	1250	100	.0052-.0064	.0211-.0259	0.001	0.004
10	3 3/16-3 1/2	3 7/16-3 1/2	3 3/16-3 7/16	100	.0050-.0064	.0201-.0257	1000	125	.0064-.0076	.0257-.0304	0.001	0.003
11	3 11/16-4	3 15/16	3 11/16-4	120	.0056-.0072	.0239-.0306	1000	150	.0072-.0088	.0306-.0373	0.001	0.003
12	-	-	4 3/16-4 1/2	80	.0059-.0075	.0241-.0306	750	100	.0075-.0091	.0306-.0371	0.001	0.005
13	-	-	4 15/16-5	90	.0069-.0087	.0288-.0362	750	115	.0087-.0105	.0362-.0436	0.001	0.005
14	-	-	5 7/16	90	.0075-.0094	.0305-.0381	500	120	.0094-.0113	.0381-.0457	0.001	0.006
15	-	-	5 15/16-6	120	.0087-.0110	.0380-.0479	500	150	.0110-.0133	.0480-.0578	0.001	0.005
16	-	-	6 7/16-7	150	.0094-.0122	.0439-.0568	500	180	.0122-.0150	.0569-.0697	0.001	0.005

Size Code	Shaft Size (Inches)	Standard Factory Adjustment (Average Speed and Temperature)					Recommended Adjustment High Speeds					Clearance Adjustment Inches Per 15 Degrees		
		6000 Series	Standard Factory Degrees Adjustment	Unmounted Radial Clearance	*Mounted Standard Radial Clearance	Unmounted Standard Axial Clearance	*Mounted Standard Axial Clearance	Speed Over	High Speed Deg. Adj.	Unmounted High Speed Radial Clearance	*Mounted High Speed Radial Clearance	Unmounted High Speed Axial Clearance	*Mounted High Speed Axial Clearance	Radial
4	1 7/16	65	.0031-.0037	.0027-.0032	.0110-.0130	.0094-.0111	2000	80	.0037-.0043	.0033-.0038	.0131-.0151	.0118-.0132	0.001	0.003
5	1 11/16	70	.0037-.0045	.0030-.0036	.0128-.0156	.0107-.0130	1500	95	.0045-.0053	.0039-.0046	.0156-.0183	.0134-.0158	0.001	0.003
6	1 15/16	105	.0041-.0049	.0036-.0043	.0157-.0188	.0135-.0161	1500	115	.0049-.0057	.0045-.0052	.0188-.0218	.0169-.0195	0.001	0.003
7	2 3/16	75	.0039-.0047	.0033-.0042	.0150-.0180	.0122-.0156	1250	85	.0047-.0055	.0042-.0051	.0180-.0210	.0156-.0191	0.001	0.004
8	2 3/8 - 2 7/16	80	.0040-.0048	.0033-.0042	.0163-.0196	.0133-.0168	1250	95	.0048-.0056	.0042-.0051	.0196-.0228	.0168-.0203	0.001	0.004
9	2 11/16 - 2 15/16	100	.0052-.0064	.0042-.0051	.0211-.0259	.0168-.0203	1250	120	.0064-.0076	.0054-.0063	.0260-.0307	.0214-.0249	0.001	0.004
10	3 3/16 - 3 7/16	125	.0064-.0076	.0055-.0063	.0257-.0304	.0214-.0249	1000	140	.0076-.0088	.0069-.0078	.0304-.0352	.0272-.0307	0.001	0.004
11	3 11/16 - 3 15/16	150	.0072-.0088	.0062-.0071	.0306-.0373	.0260-.0295	1000	170	.0084-.0100	.0079-.0087	.0357-.0423	.0330-.0365	0.001	0.004
12	4 3/16 - 4 7/16	100	.0075-.0091	.0056-.0068	.0306-.0371	.0252-.0304	750	115	.0091-.0107	.0072-.0083	.0371-.0435	.0321-.0373	0.001	0.005
13	4 15/16	115	.0087-.0105	.0071-.0084	.0362-.0436	.0286-.0339	750	135	.0105-.0123	.0093-.0106	.0436-.0510	.0373-.0425	0.001	0.005
14	5 7/16	120	.0094-.0113	.0072-.0085	.0381-.0457	.0286-.0339	500	145	.0113-.0132	.0099-.0112	.0457-.0532	.0391-.0443	0.001	0.005
15	5 15/16	150	.0110-.0133	.0091-.0103	.0480-.0578	.0391-.0443	500	180	.0133-.0156	.0115-.0128	.0579-.0677	.0495-.0547	0.001	0.005
16	6 7/16 - 6 15/16	180	.0122-.0150	.0107-.0119	.0569-.0697	.0495-.0547	500	220	.0150-.0178	.0130-.0141	.0697-.0825	.0599-.0651	0.001	0.005

Size Code	Shaft Size (Inches)	Standard Factory Adjustment (Average Speed and Temperature)					Recommended Adjustment High Speeds					Clearance Adjustment Inches Per 15 Degrees		
		9000 Series	Standard Factory Degrees Adjustment	Unmounted Radial Clearance	*Mounted Standard Radial Clearance	Unmounted Standard Axial Clearance	*Mounted Standard Axial Clearance	Speed Over	High Speed Deg. Adj.	Unmounted High Speed Radial Clearance	*Mounted High Speed Radial Clearance	Unmounted High Speed Axial Clearance	*Mounted High Speed Axial Clearance	Radial
7	1 15/16 - 2	75	.0039-.0047	.0031-.0039	.0150-.0180	.0119-.0149	1250	85	.0047-.0055	.0039-.0047	.0180-.0210	.0150-.0180	0.001	0.003
8	2 3/16	80	.0040-.0048	.0032-.0040	.0163-.0196	.0131-.0163	1250	95	.0048-.0056	.0040-.0048	.0196-.0228	.0163-.0196	0.001	0.003
9	2 7/16 - 2 1/2	100	.0052-.0064	.0040-.0052	.0211-.0259	.0163-.0211	1250	120	.0064-.0076	.0052-.0064	.0260-.0307	.0211-.0259	0.001	0.004
10	2 11/16 - 2 15/16	125	.0064-.0076	.0050-.0064	.0257-.0304	.0201-.0257	1000	140	.0076-.0088	.0064-.0076	.0304-.0352	.0257-.0304	0.001	0.003
11	3 3/16 - 3 7/16	150	.0072-.0088	.0056-.0072	.0306-.0373	.0239-.0306	1000	170	.0084-.0100	.0072-.0088	.0357-.0423	.0306-.0373	0.001	0.003
12	3 11/16 - 4	100	.0075-.0091	.0059-.0075	.0306-.0371	.0241-.0306	750	115	.0091-.0107	.0075-.0091	.0371-.0435	.0306-.0371	0.001	0.005
13	4 3/16 - 4 7/16	115	.0087-.0105	.0069-.0087	.0362-.0436	.0288-.0362	750	135	.0105-.0123	.0087-.0105	.0436-.0510	.0362-.0436	0.001	0.005
14	4 15/16 - 5	120	.0094-.0113	.0075-.0094	.0381-.0457	.0305-.0381	500	145	.0113-.0132	.0094-.0113	.0457-.0532	.0381-.0457	0.001	0.006
15	5 3/16 - 5 7/16	150	.0110-.0133	.0087-.0110	.0480-.0578	.0380-.0479	500	180	.0133-.0156	.0110-.0133	.0579-.0677	.0480-.0578	0.001	0.005
16	5 15/16 - 6 7/16	180	.0122-.0150	.0094-.0122	.0569-.0697	.0499-.0568	500	220	.0150-.0178	.0122-.0150	.0697-.0825	.0569-.0697	0.001	0.005
16	6 7/16 - 6 15/16	180	.0122-.0150	.0107-.0119	.0569-.0697	.0495-.0547	500	220	.0150-.0178	.0130-.0141	.0697-.0825	.0599-.0651	0.001	0.005

*Mounted clearance result of tightening tapered adapter

Table 3 • Rex Size Code Interchange Table

Shaft Size	REX 2000 Single Set Collar Bearing Number	REX 3000 Twist Lock Eccentric Lock Bearing Number	REX 5000 Double Set Collar Bearing Number	REX 6000 SHURLOK Tapered Adapter Bearing Number	REX 9000 Tapered Adapter Bearing Number	Size Code	Approx Outer Race Dia.
3/4 15/16 25 mm 1	2012 2015 2025MM 2100					2	2.370
1-1/8 30 mm 1-3/16 1-1/4	2102 2030MM 2103 2104					3	2.630
35 mm 1-7/16 1-1/2 1-1/2	2035MM 2107 2108	3107	5107	6107		4	2.830
40 mm 1-11/16 1-3/4 45 mm	2040MM 2111 2112 2045MM	3111	5108 5040MM 5111	6111		5	3.340
1-15/16 50 mm 2	2115 2050MM 2200	3115	5115 5050MM 8200	6115 6045MM		6	3.540
50 mm 1-15/16 2 55 mm 2-3/16 2-1/4	2055MM 2203 2204	3203	5200 5055MM 5203	6050MM 6055MM 6203	9050MM 9115 9200	7	3.940
55 mm 2-3/16 60 mm 2-3/8 2-7/16 2-1/2 65 mm	2060MM 2206 2207 2208 2065MM	3207 3208	5060MM 5207	6060MM 6206 6207	9055MM 9203	8	4.320
2-7/16 2-1/2 65 mm 2-11/16 2-3/4 70 mm 2-15/16 75 mm 3	2211 2212 2070MM 2215 2075MM 2300	3211 3215	5208 5211 5070MM 5215 5075MM 8300	6065MM 6211 6212 6070MM 6215 6075MM	9207 9208	9	5.120
2-11/16 2-15/16 3 75 mm 80 mm 3-3/16 85 mm 3-7/16 3-1/2 90 mm	2080MM 2303 2085MM 2307 2308 2090MM	3307 3308	5080MM 5303 5085MM 5307 8308 5090MM	6080MM 6303 6085MM 6307	9211 9215 9300 9075MM	10	5.900
80 mm 3-3/16 3-7/16 3-1/2 90 mm 3-11/16 100 mm 3-15/16 4	2311 2100MM 2315 2400	3315	5311 5100MM 5315 5400	6090MM 6311 6100MM 6315	9080MM 9303 9307 9308	11	7.090
3-11/16 3-15/16 4 4-3/16 110 mm 4-7/16 4-1/2 115 mm			5403Y 5110MM 5407Y 5408Y 5115MM	6403Y 6110MM 6407Y	9311Y 9315Y 9400Y	12	7.680
4-3/16 4-7/16 125 mm 4-15/16 5 130 mm			5125MM 5415 5500 5130MM	6125MM 6415	9403 9407	13	9.050
4-15/16 5 5-7/16 140 mm			5507 5140MM	6507	9415 9500	14	10.630
5-3/16 5-7/16 150 mm 5-15/16 6 160 mm			5150MM 5515 5600 5160MM	6515	9503 9507	15	11.420
5-15/16 6 6-7/16 6-1/2 6-15/16 7 180 mm			5607 5608 5615 5700 5180MM	6607 6615	9515 9600 9607	16	12.600

Table 4 • Radial Load Ratings in Pounds at Various RPM for Appropriate L₁₀ Life Hours

Size Code	L ₁₀ Minimum Life Hours	Speed, RPM																	
		50	100	200	300	400	500	600	700	800	900	1000	1200	1500	1800	2000	2500	3000	3500
2	8000	*	*	*	3449	3164	2959	2802	2675	2570	2481	2404	2276	2128	2015	1952	1826	1729	1651
	20000	*	3643	2959	2620	2404	2248	2128	2032	1952	1885	1826	1729	1617	1531	1483	1387	1313	1254
	40000	3643	2959	2404	2128	1952	1826	1729	1651	1586	1531	1483	1404	1313	1243	1205	1127	1067	1018
	100000	2768	2248	1826	1617	1483	1387	1313	1254	1205	1163	1127	1067	998	945	915	856	810	774
3	8000	*	*	*	4243	3893	3640	3447	3291	3162	3052	2957	2800	2618	2479	2402	2246	2127	2031
	20000	*	4482	3640	3224	2957	2766	2618	2500	2402	2318	2246	2127	1989	1883	1825	1706	1616	1543
	40000	4482	3640	2957	2618	2402	2246	2127	2031	1951	1883	1825	1727	1616	1530	1482	1386	1312	1253
	100000	3405	2766	2246	1989	1825	1706	1616	1543	1482	1431	1386	1312	1227	1162	1126	1053	997	952
4	8000	*	*	*	4471	4101	3836	3631	3467	3331	3215	3115	2950	2759	2612	2531	2367	2241	2139
	20000	*	4722	3836	3396	3115	2914	2759	2634	2531	2443	2367	2241	2096	1984	1922	1798	1702	1625
	40000	4722	3836	3115	2759	2531	2367	2241	2139	2055	1984	1922	1820	1702	1612	1561	1460	1383	1320
	100000	3587	2914	2367	2096	1922	1798	1702	1625	1561	1507	1460	1383	1293	1224	1186	1109	1050	1003
5	8000	*	*	*	6263	5745	5373	5087	4857	4666	4504	4364	4132	3864	3659	3545	3315	3139	2997
	20000	*	6615	5373	4757	4364	3864	3690	3545	3422	3315	3139	2935	2779	2693	2518	2384	2277	2277
	40000	6615	5373	4364	3864	3545	3315	3139	2997	2879	2779	2693	2549	2384	2257	2187	2046	1937	1849
	100000	5025	4081	3315	2935	2693	2518	2384	2277	2187	2111	2046	1937	1811	1715	1662	1554	1471	1405
6	8000	*	*	*	6504	5966	5580	5283	5044	4846	4678	4532	4291	4013	3800	3681	3443	3260	3112
	20000	*	6870	5580	4941	4532	4239	4013	3832	3681	3554	3443	3260	3049	2886	2797	2615	2476	2364
	40000	6870	5580	4532	4013	3681	3443	3260	3112	2990	2886	2797	2648	2476	2344	2272	2124	2011	1920
	100000	5219	4239	3443	3049	2797	2615	2476	2364	2272	2193	2124	2011	1881	1781	1726	1614	1528	1459
7	8000	*	*	*	8189	7512	7026	6652	6351	6102	5890	5707	5403	5053	4784	4635	4335	4104	3919
	20000	*	8649	7026	6221	5707	5337	5053	4825	4635	4474	4335	4104	3839	3634	3521	3293	3118	2977
	40000	8649	7026	5707	5053	4635	4335	4104	3919	3765	3634	3521	3334	3118	2952	2860	2675	2532	2418
	100000	6571	5337	4335	3839	3521	3293	3118	2977	2860	2761	2675	2532	2368	2242	2173	2032	1924	1837
8	8000	*	*	*	9735	8930	8352	7907	7550	7254	7002	6784	6423	6007	5687	5510	5153	4879	4679
	20000	*	10283	8352	7395	6784	6345	6007	5736	5510	5319	5153	4879	4563	4320	4186	3915	3707	3501
	40000	10283	8352	6784	6007	5510	5153	4879	4659	4476	4320	4186	3963	3707	3509	3400	3180	3011	
	100000	7811	6345	5153	4563	4186	3915	3707	3539	3400	3282	3180	3011	2816	2666	2583	2416	2287	
9	8000	*	*	*	13003	11927	11155	10561	10084	9688	9352	9061	8578	8023	7596	7360	6883	6429	6095
	20000	*	13734	11155	9877	9061	8474	8023	7660	7360	7104	6883	6517	6095	5770	5591	5229	4951	4729
	40000	13734	11155	9061	8023	7360	6883	6517	6222	5978	5770	5591	5293	4950	4687	4541	4247	4021	3826
	100000	10433	8474	6883	6095	5591	5229	4950	4727	4541	4383	4247	4021	3761	3560	3450	3226		
10	8000	*	*	*	18987	17417	16289	15422	14725	14147	13656	13231	12526	11715	11092	10747	10051	9516	8900
	20000	*	20054	16289	14423	13231	12374	11715	11186	10747	10374	10051	9516	8900	8426	8164	7635	7229	6844
	40000	20054	16289	13231	11715	10747	10051	9516	9086	8729	8426	8164	7729	7229	6844	6631	6202	5919	5607
	100000	15234	12374	10051	8900	8164	7635	7229	6902	6631	6401	6202	5872	5491	5199	5037	4711		
11	8000	*	*	*	29487	27049	25298	23951	22869	21971	21208	20548	19454	18195	17226	16690	15609	14779	13822
	20000	*	31145	25298	22400	20548	19217	18195	17372	16690	16111	15609	14779	13822	13086	12679	12004	11227	10629
	40000	31145	25298	20548	18195	16690	15609	14779	14111	13557	13086	12679	12004	11227	10629	10298	9735	9217	
	100000	23660	19217	15609	13822	12679	11858	11227	10719	10298	9941	9632	9119	8528	8074	7823			
12	8000	*	*	*	33661	30877	28878	27341	26105	25080	24209	23456	22208	20770	19664	18780	17778	16938	16233
	20000	*	35553	28878	25570	23456	21937	20770	19831	19052	18391	17819	16870	15778	14938	14333	13703	12816	12133
	40000	35553	28878	23456	20770	19052	17819	16870	16108	15475	14938	14473	13703	12816	12133	11533	10933	10333	
	100000	27008	21937	17819	15778	14473	13536	12816	12236	11756	11348	10995	10409	9735	9217				
13	8000	*	*	*	43026	39469	36913	34948	33369	32058	30945	29983	28387	26549	25168	23887	22777	21564	20168
	20000	*	45445	36913	32685	29983	28041	26549	25349	24353	23508	22777	21564	20168	18887	17777	16564	15168	
	40000	45445	36913	29983	26549	24353	22777	21564	20590	19781	19094	18500	17516	16381	15387	14444	13500	12644	
	100000	34523	28041	22777	20168	18500	17302	16381	15641	15027	14505	14054	13306	12444					
14	8000	*	*	*	51700	47425	44355	41994	40096	38521	37184	36027	34553	32887	31387	29983	28687	27387	26187
	20000	*	54607	44355	39275	36027	33694	31901	30459	29263	28247	27368	26444	25564	24744	23924	23104	22284	21464
	40000	54607	44355	36027	31901	29263	27368	25912	24741	23769	22944	22230	21516	20802	20088	19374	18660	17946	
	100000	41483	33694	27368	24234	22230	20791	19684	18794	18056	17429	16887	16345	15803	15261	14719	14177	13635	
15	8000	*	*	*	55885	51264	47944	45392	43341	41639	40194	38943	37492	35941	34490	33039	31588	30137	28686
	20000	*	59027	47944	42453	38943	36421	34483	32924	31632	30533	29583	28633	27683	26733	25783	24833	23883	22933
	40000	59027	47944	38943	34483	31632	29583	28009	26743	25693	24801	24029	23257	22485	21713	20941	20169	19397	
	100000	44840	36421	29583	26195	24029	22473	21277	20315	19518	18840	18254	17668	17082	16496	15910	15324	14738	
16	8000	*	*	*	69766	63998	59854	56668	54107	51982	50107	48282	46457	44632	42807	41182	39557	37932	36307
	20000	*	73689	59854	52998	48616	45468	43048	41103	39489	38064	36639	35214	33789	32364	30939	29514	28089	
	40000	73689	59854	48616	43048	39489	36932	34966	33386	32075	30864	29653	28442	27231	26020	24809	23598		
	100000	55978	45468	36932	32702	29998	28055	26562	25362	24366	23370	22374	21378	20382	19386	18390	17394		

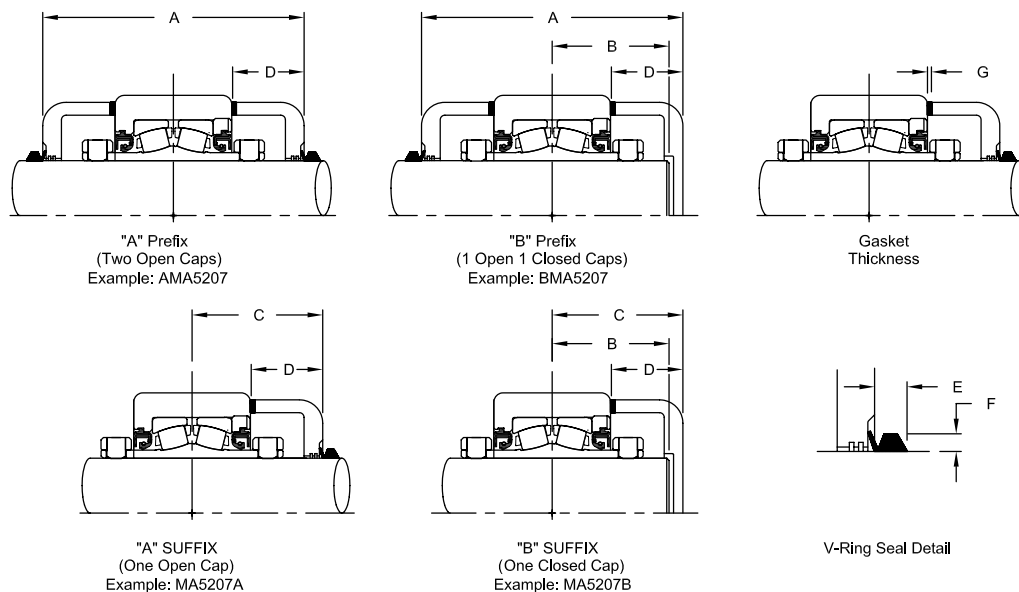
*Load exceeds 25% of the C rating, consult Rexnord Bearing Division.

Shaded areas may require additional axial clearance and/or high speed temperature lubricant due to higher operating temperatures.

Auxiliary Cap Seals for 2000, 3000, 5000, 9000 Series

Kit Nomenclature

Symbol	Description	A	S	9	-	2	1	5
A	open cap	-----						
B	closed cap	-----						
S	floating type	-----						
*	leave blank for fixed type	-----						
4-16	bearing size code from dimension page	-----						
215	2 15/16" last two digits in 16th of an inch	-----						
*	not required for closed style caps	-----						



Cast Iron Auxiliary Cap

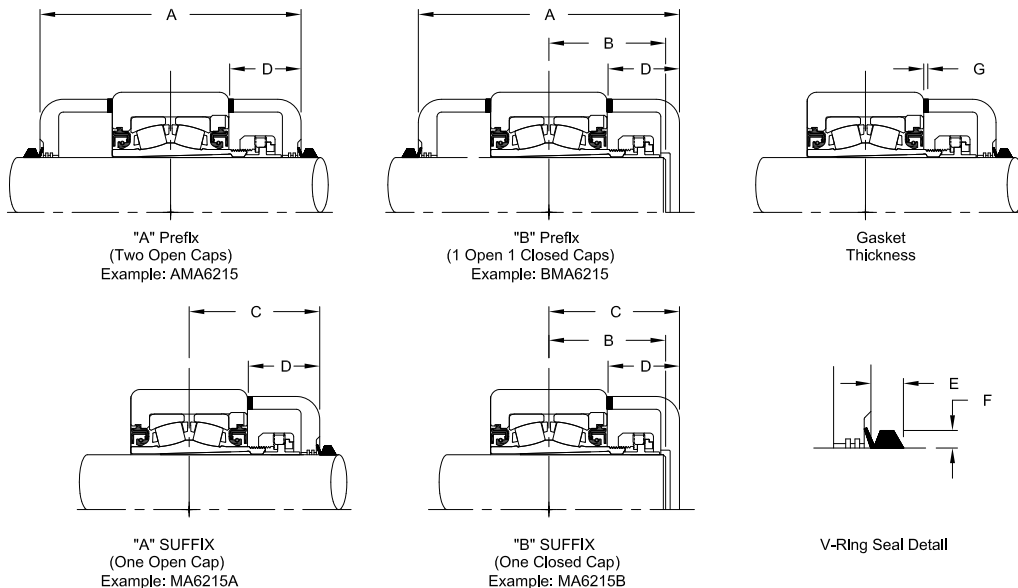
Size Code	Fixed Bearings Only				Floating (Expansion) Bearings Only				V-Ring Seal		Gasket G
	A	B	C	D*	A	B	C	D*	E	F	
4	5 5/16	2 5/16	2 11/16	1 9/16	5 1/2	2 3/8	2 3/4	1 17/32	5/16	3/16	3/16
5	5 1/2	2 7/16	2 3/4	1 17/32	5 3/4	2 1/2	2 7/8	1 15/32	3/8	3/16	
6	5 9/16	2 7/16	2 13/16	1 9/16	5 3/4	2 1/2	2 7/8	1 17/32			
7	5 3/4	2 1/2	2 7/8	1 19/32	6 1/16	2 5/8	3 1/16	1 21/32			
8	6 1/16	2 3/4	3 1/16	1 23/32	6 5/16	2 3/4	3 3/16	1 23/32	7/16	1/4	
9	7	3 1/8	3 1/2	1 15/16	6 15/16	3 1/16	3 1/2	1 25/32			
10	6 15/16	3 1/16	3 1/2	1 13/16	7 3/8	3 5/8	3 11/16	1 29/32			
11	8 5/16	3 5/8	4 3/16	2 5/32	8 9/16	3 3/4	4 5/16	2 5/32	9/16	5/16	
12	8 1/2	3 3/4	4 1/4	2 3/16	9 3/8	4 5/16	4 11/16	2 1/2			
13	10 1/8	4 1/2	5 1/16	2 9/32	10 9/16	4 3/4	5 5/16	2 9/32			
14	10 1/8	4 1/2	5 1/16	2 9/32	11 1/16	5	5 9/16	2 5/8			
15	11 1/16	4 15/16	5 9/16	2 5/8	11 1/2	4 15/16	5 3/4	2 3/4	5/8	3/8	
16	11 3/16	5	5 5/8	2 1/2	11 5/8	5 1/4	5 13/16	2 5/8			

Adapter Auxiliary End Cap Dimensions for 6000 Series Size Codes 6-13

Kit Nomenclature

Symbol	Description
A	open cap
B	closed cap
S	floating type
*	leave blank for fixed type
6-13	bearing size code from dimension page
6	type "A" open caps
6000	type "B" closed caps
215	2-15/16" last two digits in 16th of an inch
*	not required for closed style caps

A S 9 6 2 1 5



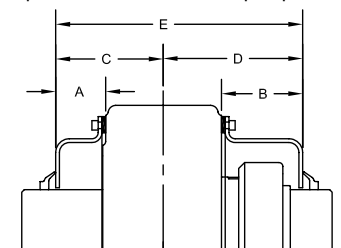
6000 Series Adapter Mount Auxiliary Cap Dimensions

Cast Iron Auxiliary Caps																
Bearing Number	Size Code	Fixed Bearings Only				Floating (Expansion) ZAFS Bearings Only				Floating (Expansion) ZPS, ZFS Bearings Only				V-Ring Seal		Gasket
		A	B	C	D	A	B	C	D	A	B	C	D	E	F	
6115	6	5 7/8	2 9/16	2 15/16	1 23/32	6 1/4	2 11/16	3 1/8	1 29/32	6 1/2	2 13/16	3 1/4	1 29/32	3/8	3/16	3/16
6203	7	6 1/16	2 5/8	3 1/32	1 3/4	6 7/16	2 25/32	3 7/32	1 15/16	6 5/8	2 7/8	3 5/16	1 15/16			
6206	8	6 11/16	3 1/32	3 11/32	2 1/32	7 3/16	3 5/32	3 19/32	2 9/32	7 7/16	3 9/32	3 23/32	2 9/32			
6207																
6211	9	7 1/4	3 1/16	3 5/8	2 1/16	7 3/4	3 7/16	3 7/8	2 5/16	8	3 9/16	4	2 5/16	7/16	1/4	
6212																
6215																
6303	10	7 15/16	3 17/32	3 31/32	2 1/4	8 7/16	3 25/32	4 7/32	2 1/2	8 11/16	3 29/32	4 11/32	2 1/2			
6307																
6311																
6315	11	9	3 15/16	4 1/2	2 7/16	9 1/2	4 3/16	4 3/4	2 11/16	9 3/4	4 5/16	4 7/8	2 11/16			
6403Y																
6407Y	12	9 7/16	4 5/32	4 23/32	2 19/32	10 3/16	4 21/32	5 3/32	2 31/32	10 7/16	4 31/32	5 7/32	2 31/32	9/16	5/16	
6415																
6415	13	11 5/8	5 1/4	5 13/16	3 1/32	12 3/8	5 5/8	6 3/16	3 13/32	12 13/16	5 27/32	6 13/32	3 13/32			

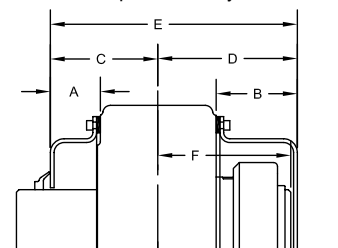
Adapter Auxiliary End Cap Dimensions for 6000 Series Size Codes 14-16

Kit Nomenclature

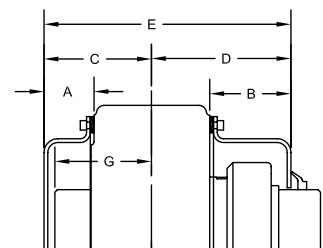
Symbol	Description	A	S	LN	14	6	507
A	open cap	-----	-----	-----	-----	-----	-----
B	closed cap						
S	floating type or ZLF, ZLFS	-----		-----	-----	-----	-----
*	leave blank for fixed type						
LN	for locknut side	-----		-----	-----	-----	-----
*	leave blank for non-locknut side						
14-16	bearing size code from dimension page	-----		-----	-----	-----	-----
6	type "A" open caps						
6000	type "B" closed caps	-----		-----	-----	-----	-----
507	5-7/16" last two digits in 16th of an inch						
*	not required for closed style caps	-----		-----	-----	-----	-----
	LN kits provided with extended cap to provide clearance over adapter assembly.						



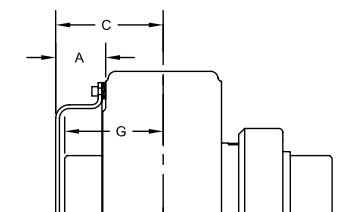
"A" Prefix
(2 Open Caps)
Example: AZAF6515F



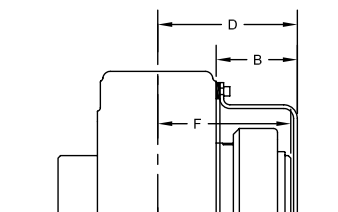
"BA" Prefix
(1 Closed Cap Locknut Slide 1 Open Cap Housing slide)
Example: BAZAF6515F



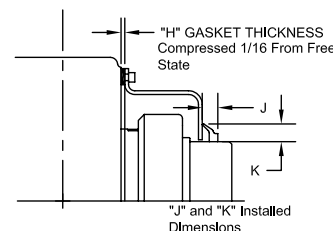
"AB" Prefix
(1 Open Cap Locknut Slide 1 Closed Cap Housing slide)
Example: ABZAF6515F



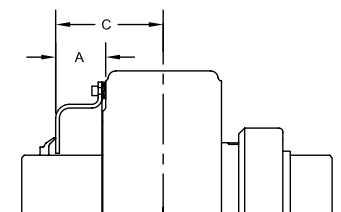
"B66" Suffix
(1 Closed Cap Locknut Side "Opposite Locknut")
Example: ZAF6515FB66



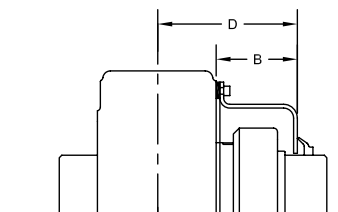
"B" Suffix
(1 Closed Cap Locknut Side)
Example: ZAF6515FB



"J" and "K" Installed Dimensions



"A66" Suffix
(1 Open Cap Housing side "Opposite Locknut")
Example: ZAF6515FA66



"A" Suffix
(1 Open Cap Locknut Side)
Example: ZAF6515FA

6000 Series Adapter Mount Auxiliary Cap Dimensions (Size codes 14-16)

Steel Auxiliary Caps																			
Bearing Number	Size Code	Fixed Bearings Only (No ZLF)									Floating (Expansion) ZPS, ZAFS Bearings Only							V-Ring Seal	
		A	B	C	D	E	F	G	*H	A	B	C	D	E	F	G	**H	J	K
6507	14	2 5/32	3 11/16	4 29/32	6 1/2	11 13/32	6 1/8	4 3/16	3/16	2 11/16	3 31/32	5 19/32	6 7/8	12 15/32	4 1/2	6 1/8	3/8	5/8	3/4
6515	15	2 1/2	4 1/16	5 3/8	6 63/64	12 23/64	6 5/8	4 11/16	3/16	2 9/16	4 3/8	5 9/16	7 3/8	12 15/16	6 5/8	4 3/8	3/8	45/64	7/8
6607	16	2 3/8	4 5/16	5 7/16	7 13/32	12 27/32	7	4 3/4	3/16	2 11/16	4 5/8	5 7/8	7 13/16	13 11/16	7	4 3/4	3/8	45/64	7/8
6615																		45/64	7/8
Bearing Number	Size Code	ZLF-ZLFS Split Housed Bearings Only									V-Ring Seal		*H-compressed thickness. Free state is 1/4"						
		A	B	C	D	E	F	G	*H	J	K	**H-compressed thickness. Free state 1/4. 2 gaskets required							
6507	14	2 1/2	3 25/32	5 7/8	7 5/32	13 1/32	6	5 3/16	3/16	5/8	3/4								
6515	15	2 3/8	4 3/16	5 7/8	7 11/16	13 9/16	6 1/2	5 3/16	3/16	45/64	7/8								
6607	16	2 1/2	4 7/16	6 3/16	8 1/8	14 5/16	6 7/8	5 1/2	3/16	45/64	7/8								
6615										45/64	7/8								

Auxiliary Cap Kit

Auxiliary Cap Kit Part Number by Housing Style ‡

Size Code	Series	Aux Cap Style	HousingType													
			ZA	ZAS	ZEP	ZEPS	ZP	ZPS	ZAF	ZAFS	ZLF	ZLFS	ZB ◊	ZBS	ZF ◊	
2	2000	Open	N/A	N/A	N/A	N/A	N/A	N/A	N/A	N/A	N/A	N/A	N/A	N/A	N/A	N/A
		Closed	N/A	N/A	N/A	N/A	N/A	N/A	N/A	N/A	N/A	N/A	N/A	N/A	N/A	N/A
3	2000	Open	N/A	N/A	N/A	N/A	N/A	N/A	N/A	N/A	N/A	N/A	N/A	N/A	N/A	N/A
		Closed	N/A	N/A	N/A	N/A	N/A	N/A	N/A	N/A	N/A	N/A	N/A	N/A	N/A	N/A
4	2000	Open	A4***	N/A	A4***	N/A	A4***	AS4***	N/A	N/A	N/A	N/A	N/A	N/A	N/A	A4***
		Closed	B4	N/A	B4	N/A	B4	BS4	N/A	N/A	N/A	N/A	N/A	N/A	N/A	B4
	3000	Open	A4***	N/A	A4***	N/A	A4***	AS4***	N/A	N/A	N/A	N/A	N/A	N/A	N/A	A4***
		Closed	B4	N/A	B4	N/A	B4	BS4	N/A	N/A	N/A	N/A	N/A	N/A	N/A	B4
	5000	Open	A4***	N/A	A4***	N/A	A4***	AS4***	N/A	N/A	N/A	N/A	N/A	N/A	N/A	A4***
		Closed	B4	N/A	B4	N/A	B4	BS4	N/A	N/A	N/A	N/A	N/A	N/A	N/A	B4
5	2000	Open	N/A	N/A	N/A	N/A	N/A	N/A	N/A	N/A	N/A	N/A	N/A	N/A	N/A	N/A
		Closed	N/A	N/A	N/A	N/A	N/A	N/A	N/A	N/A	N/A	N/A	N/A	N/A	N/A	N/A
	3000	Open	A5***	N/A	A5***	N/A	A5***	AS5***	N/A	N/A	N/A	N/A	N/A	N/A	N/A	A5***
		Closed	B5	N/A	B5	N/A	B5	BS5	N/A	N/A	N/A	N/A	N/A	N/A	N/A	B5
	5000	Open	A5***	N/A	A5***	N/A	A5***	AS5***	N/A	N/A	N/A	N/A	N/A	N/A	N/A	A5***
		Closed	B5	N/A	B5	N/A	B5	BS5	N/A	N/A	N/A	N/A	N/A	N/A	N/A	B5
6	2000	Open	N/A	N/A	N/A	N/A	N/A	N/A	N/A	N/A	N/A	N/A	N/A	N/A	N/A	N/A
		Closed	N/A	N/A	N/A	N/A	N/A	N/A	N/A	N/A	N/A	N/A	N/A	N/A	N/A	N/A
	3000	Open	A6***	N/A	A6***	N/A	A6***	AS6***	A6***	AS6***	N/A	N/A	N/A	N/A	N/A	A6***
		Closed	B6	N/A	B6	N/A	B6	BS6	B6	BS6	N/A	N/A	N/A	N/A	N/A	B6
	5000	Open	A6***	N/A	A6***	N/A	A6***	AS6***	A6***	AS6***	N/A	N/A	N/A	N/A	N/A	A6***
		Closed	B6	N/A	B6	N/A	B6	BS6	B6	BS6	N/A	N/A	N/A	N/A	N/A	B6
7	2000	Open	A66***	N/A	A66***	N/A	A66***	AS66***	A66***	AS66***	N/A	N/A	N/A	N/A	N/A	A66***
		Closed	B66000	N/A	B66000	N/A	B66000	BS66000	B66000	BS66000	N/A	N/A	N/A	N/A	N/A	B66000
	3000	Open	A7***	N/A	A7***	N/A	A7***	AS7***	A7***	AS7***	N/A	N/A	A7***	N/A	A7***	A7***
		Closed	B7	N/A	B7	N/A	B7	BS7	B7	BS7	N/A	N/A	B7	N/A	B7	B7
	5000	Open	A7***	N/A	A7***	N/A	A7***	AS7***	A7***	AS7***	N/A	N/A	A7***	N/A	A7***	A7***
		Closed	B7	N/A	B7	N/A	B7	BS7	B7	BS7	N/A	N/A	B7	N/A	B7	B7
8	2000	Open	A76***	N/A	A76***	N/A	A76***	AS76***	A76***	AS76***	N/A	N/A	A76***	N/A	A76***	A76***
		Closed	B76000	N/A	B76000	N/A	B76000	BS76000	B76000	BS76000	N/A	N/A	B76000	N/A	B76000	B76000
	3000	Open	A7***	N/A	A7***	N/A	A7***	AS7***	A7***	AS7***	N/A	N/A	A7***	N/A	A7***	A7***
		Closed	B7	N/A	B7	N/A	B7	BS7	B7	BS7	N/A	N/A	B7	N/A	B7	B7
	5000	Open	A7***	N/A	A7***	N/A	A7***	AS7***	A7***	AS7***	N/A	N/A	A7***	N/A	A7***	A7***
		Closed	B7	N/A	B7	N/A	B7	BS7	B7	BS7	N/A	N/A	B7	N/A	B7	B7
9	2000	Open	A8***	N/A	A8***	N/A	A8***	AS8***	A8***	AS8***	N/A	N/A	A8***	N/A	A8***	A8***
		Closed	B8	N/A	B8	N/A	B8	BS8	B8	BS8	N/A	N/A	B8	N/A	B8	B8
	3000	Open	A8***	N/A	A8***	N/A	A8***	AS8***	A8***	AS8***	N/A	N/A	A8***	N/A	A8***	A8***
		Closed	B8	N/A	B8	N/A	B8	BS8	B8	BS8	N/A	N/A	B8	N/A	B8	B8
	5000	Open	A8***	N/A	A8***	N/A	A8***	AS8***	A8***	AS8***	N/A	N/A	A8***	N/A	A8***	A8***
		Closed	B8	N/A	B8	N/A	B8	BS8	B8	BS8	N/A	N/A	B8	N/A	B8	B8
10	2000	Open	A86***	N/A	A86***	N/A	A86***	AS86***	A86***	AS86***	N/A	N/A	A86***	N/A	A86***	A86***
		Closed	B86000	N/A	B86000	N/A	B86000	BS86000	B86000	BS86000	N/A	N/A	B86000	N/A	B86000	B86000
	3000	Open	A8***	N/A	A8***	N/A	A8***	AS8***	A8***	AS8***	N/A	N/A	A8***	N/A	A8***	A8***
		Closed	B8	N/A	B8	N/A	B8	BS8	B8	BS8	N/A	N/A	B8	N/A	B8	B8
	5000	Open	A8***	N/A	A8***	N/A	A8***	AS8***	A8***	AS8***	N/A	N/A	A8***	N/A	A8***	A8***
		Closed	B8	N/A	B8	N/A	B8	BS8	B8	BS8	N/A	N/A	B8	N/A	B8	B8
11	2000	Open	A9***	N/A	A9***	N/A	A9***	AS9***	A9***	AS9***	N/A	N/A	A9***	N/A	A9***	A9***
		Closed	B9	N/A	B9	N/A	B9	BS9	B9	BS9	N/A	N/A	B9	N/A	B9	B9
	3000	Open	A9***	N/A	A9***	N/A	A9***	AS9***	A9***	AS9***	N/A	N/A	A9***	N/A	A9***	A9***
		Closed	B9	N/A	B9	N/A	B9	BS9	B9	BS9	N/A	N/A	B9	N/A	B9	B9
	5000	Open	A9***	N/A	A9***	N/A	A9***	AS9***	A9***	AS9***	N/A	N/A	A9***	N/A	A9***	A9***
		Closed	B9	N/A	B9	N/A	B9	BS9	B9	BS9	N/A	N/A	B9	N/A	B9	B9
12	2000	Open	A96***	N/A	A96***	N/A	A96***	AS96***	A96***	AS96***	N/A	N/A	A96***	N/A	A96***	A96***
		Closed	B96000	N/A	B96000	N/A	B96000	BS96000	B96000	BS96000	N/A	N/A	B96000	N/A	B96000	B96000
	3000	Open	A9***	N/A	A9***	N/A	A9***	AS9***	A9***	AS9***	N/A	N/A	A9***	N/A	A9***	A9***
		Closed	B9	N/A	B9	N/A	B9	BS9	B9	BS9	N/A	N/A	B9	N/A	B9	B9
	5000	Open	A9***	N/A	A9***	N/A	A9***	AS9***	A9***	AS9***	N/A	N/A	A9***	N/A	A9***	A9***
		Closed	B9	N/A	B9	N/A	B9	BS9	B9	BS9	N/A	N/A	B9	N/A	B9	B9
13	2000	Open	A10***	N/A	A10***	N/A	A10***	AS10***	A10***	AS10***	N/A	N/A	A10***	N/A	A10***	A10***
		Closed	B10	N/A	B10	N/A	B10	BS10	B10	BS10	N/A	N/A	B10	N/A	B10	B10
	3000	Open	A10***	N/A	A10***	N/A	A10***	AS10***	A10***	AS10***	N/A	N/A	A10***	N/A	A10***	A10***
		Closed	B10	N/A	B10	N/A	B10	BS10	B10	BS10	N/A	N/A	B10	N/A	B10	B10
	5000	Open	A106***	N/A	A106***	N/A	A106***	AS106***	A106***	AS106***	N/A	N/A	A106***	N/A	A106***	A106***
		Closed	B106000	N/A	B106000	N/A	B106000	BS106000	B106000	BS106000	N/A	N/A	B106000	N/A	B106000	B106000
14	2000	Open	A10***	N/A	A10***	N/A	A10***	AS10***	A10***	AS10***	N/A	N/A	A10***	N/A	A10***	A10***
		Closed	B10	N/A	B10	N/A	B10	BS10	B10	BS10	N/A	N/A	B10	N/A	B10	B10
	3000	Open	A11***	N/A	A11***	N/A	A11***	AS11***	A11***	AS11***	N/A	N/A	A11***	N/A	A11***	A11***
		Closed	B11	N/A	B11	N/A	B11	BS11	B11	BS11	N/A	N/A	B11	N/A	B11	B11
	5000	Open	A11***	N/A	A11***	N/A	A11***	AS11***	A11***	AS11***	N/A	N/A	A11***	N/A	A11***	A11***
		Closed	B11	N/A	B11	N/A	B11	BS11	B11	BS11	N/A	N/A	B11	N/A	B11	B11
9000	Open	A116***	N/A	A116***	N/A	A116***	AS116***	A116***	AS116***	N/A	N/A	A116***	N/A	A116***	A116***	
	Closed	B116000	N/A	B116000	N/A	B116000	BS116000	B116000	BS116000	N/A	N/A	B116000	N/A	B116000	B116000	

Auxiliary Cap Kit Part Number by Housing Style ‡ (Continued)

Size Code	Series	Aux Cap Style	Housing Type															
			ZA	ZAS	ZEP	ZEPS	ZP	ZPS	ZAF	ZAFS	ZLF	ZLFS	ZB ◊	ZBS	ZF ◊			
12	2000	Open	N/A	N/A	N/A	N/A	N/A	N/A	N/A	N/A	N/A	N/A	N/A	N/A	N/A	N/A	N/A	
		Closed	N/A	N/A	N/A	N/A	N/A	N/A	N/A	N/A	N/A	N/A	N/A	N/A	N/A	N/A	N/A	
	3000	Open	N/A	N/A	N/A	N/A	N/A	N/A	N/A	N/A	N/A	N/A	N/A	N/A	N/A	N/A	N/A	
		Closed	N/A	N/A	N/A	N/A	N/A	N/A	N/A	N/A	N/A	N/A	N/A	N/A	N/A	N/A	N/A	
	5000	Open	N/A	N/A	N/A	N/A	A12***	AS12***	A12***	AS12***	N/A	N/A	N/A	N/A	N/A	A12***		
		Closed	N/A	N/A	N/A	N/A	B12	BS12	B12	BS12	N/A	N/A	N/A	N/A	N/A	B12		
	6000	Open	N/A	N/A	A126***	N/A	A126***	AS126***	A126***	AS126***	N/A	N/A	N/A	N/A	N/A	A126***		
		Closed	N/A	N/A	B126000	N/A	B126000	BS126000	B126000	BS126000	N/A	N/A	N/A	N/A	N/A	B126000		
	9000	Open	N/A	N/A	A12***	N/A	A12***	AS12***	A12***	AS12***	N/A	N/A	N/A	N/A	N/A	A12***		
		Closed	N/A	N/A	B12	N/A	B12	BS12	B12	BS12	N/A	N/A	N/A	N/A	N/A	B12		
	13	2000	Open	N/A	N/A	N/A	N/A	N/A	N/A	N/A	N/A	N/A	N/A	N/A	N/A	N/A	N/A	N/A
			Closed	N/A	N/A	N/A	N/A	N/A	N/A	N/A	N/A	N/A	N/A	N/A	N/A	N/A	N/A	N/A
3000		Open	N/A	N/A	N/A	N/A	N/A	N/A	N/A	N/A	N/A	N/A	N/A	N/A	N/A	N/A	N/A	
		Closed	N/A	N/A	N/A	N/A	N/A	N/A	N/A	N/A	N/A	N/A	N/A	N/A	N/A	N/A	N/A	
5000		Open	N/A	N/A	N/A	N/A	A13***	AS13***	A13***	AS13***	N/A	N/A	N/A	N/A	N/A	A13***		
		Closed	N/A	N/A	N/A	N/A	B13	BS13	B13	BS13	N/A	N/A	N/A	N/A	N/A	B13		
6000		Open	N/A	N/A	A136***	N/A	A136***	AS136***	A136***	AS136***	N/A	N/A	N/A	N/A	N/A	A136***		
		Closed	N/A	N/A	B136000	N/A	B136000	BS136000	B136000	BS136000	N/A	N/A	N/A	N/A	N/A	B136000		
9000		Open	N/A	N/A	A13***	N/A	A13***	AS13***	A13***	AS13***	N/A	N/A	N/A	N/A	N/A	A13***		
		Closed	N/A	N/A	B13	N/A	B13	BS13	B13	BS13	N/A	N/A	N/A	N/A	N/A	B13		
14		2000	Open	N/A	N/A	N/A	N/A	N/A	N/A	N/A	N/A	N/A	N/A	N/A	N/A	N/A	N/A	N/A
			Closed	N/A	N/A	N/A	N/A	N/A	N/A	N/A	N/A	N/A	N/A	N/A	N/A	N/A	N/A	N/A
	3000	Open	N/A	N/A	N/A	N/A	N/A	N/A	N/A	N/A	N/A	N/A	N/A	N/A	N/A	N/A	N/A	
		Closed	N/A	N/A	N/A	N/A	N/A	N/A	N/A	N/A	N/A	N/A	N/A	N/A	N/A	N/A	N/A	
	5000	Open	N/A	N/A	N/A	N/A	A14***	AS14***	A14***	AS14***	N/A	N/A	N/A	N/A	N/A	N/A	N/A	
		Closed	N/A	N/A	N/A	N/A	B14	BS14	B14	BS14	N/A	N/A	N/A	N/A	N/A	N/A	N/A	
	6000	Open Locknut Side	N/A	N/A	N/A	N/A	ALN146***	ALN146***	ALN146***	ALN146***	ASLN146***	ASLN146***	N/A	N/A	N/A	N/A	N/A	
		Open Non Locknut Side	N/A	N/A	N/A	N/A	A146***	A146***	A146***	A146***	AS146***	AS146***	N/A	N/A	N/A	N/A	N/A	
		Closed Locknut Side	N/A	N/A	N/A	N/A	BLN146000	BLN146000	BLN146000	BLN146000	BSLN146000	BSLN146000	N/A	N/A	N/A	N/A	N/A	
		Closed Non Locknut Side	N/A	N/A	N/A	N/A	B146000	BS146000	B146000	BS146000	BS146000	BS146000	N/A	N/A	N/A	N/A	N/A	
	9000	Open	N/A	N/A	N/A	N/A	A14***	AS14***	A14***	AS14***	N/A	N/A	N/A	N/A	N/A	N/A	N/A	
		Closed	N/A	N/A	N/A	N/A	B14	BS14	B14	BS14	N/A	N/A	N/A	N/A	N/A	N/A	N/A	
2000	Open	N/A	N/A	N/A	N/A	N/A	N/A	N/A	N/A	N/A	N/A	N/A	N/A	N/A	N/A	N/A		
	Closed	N/A	N/A	N/A	N/A	N/A	N/A	N/A	N/A	N/A	N/A	N/A	N/A	N/A	N/A	N/A		
3000	Open	N/A	N/A	N/A	N/A	N/A	N/A	N/A	N/A	N/A	N/A	N/A	N/A	N/A	N/A	N/A		
	Closed	N/A	N/A	N/A	N/A	N/A	N/A	N/A	N/A	N/A	N/A	N/A	N/A	N/A	N/A	N/A		
5000	Open	N/A	N/A	N/A	N/A	A15***	AS15***	A15***	AS15***	N/A	N/A	N/A	N/A	N/A	N/A	N/A		
	Closed	N/A	N/A	N/A	N/A	B15	BS15	B15	BS15	N/A	N/A	N/A	N/A	N/A	N/A	N/A		
15	6000	Open Locknut Side	N/A	N/A	N/A	N/A	ALN156***	ALN156***	ALN156***	ALN156***	ASLN156***	ASLN156***	N/A	N/A	N/A	N/A	N/A	
		Open Non Locknut Side	N/A	N/A	N/A	N/A	A156***	A156***	A156***	A156***	AS156***	AS156***	N/A	N/A	N/A	N/A	N/A	
		Closed Locknut Side	N/A	N/A	N/A	N/A	BLN156000	BLN156000	BLN156000	BLN156000	BSLN156000	BSLN156000	N/A	N/A	N/A	N/A	N/A	
		Closed Non Locknut Side	N/A	N/A	N/A	N/A	B156000	BS156000	B156000	BS156000	BS156000	BS156000	N/A	N/A	N/A	N/A	N/A	
9000	Open	N/A	N/A	N/A	N/A	A15***	AS15***	A15***	AS15***	N/A	N/A	N/A	N/A	N/A	N/A	N/A		
	Closed	N/A	N/A	N/A	N/A	B15	BS15	B15	BS15	N/A	N/A	N/A	N/A	N/A	N/A	N/A		
2000	Open	N/A	N/A	N/A	N/A	N/A	N/A	N/A	N/A	N/A	N/A	N/A	N/A	N/A	N/A	N/A		
	Closed	N/A	N/A	N/A	N/A	N/A	N/A	N/A	N/A	N/A	N/A	N/A	N/A	N/A	N/A	N/A		
3000	Open	N/A	N/A	N/A	N/A	N/A	N/A	N/A	N/A	N/A	N/A	N/A	N/A	N/A	N/A	N/A		
	Closed	N/A	N/A	N/A	N/A	N/A	N/A	N/A	N/A	N/A	N/A	N/A	N/A	N/A	N/A	N/A		
5000	Open	N/A	N/A	N/A	N/A	A16***	AS16***	A16***	AS16***	N/A	N/A	N/A	N/A	N/A	N/A	N/A		
	Closed	N/A	N/A	N/A	N/A	B16	BS16	B16	BS16	N/A	N/A	N/A	N/A	N/A	N/A	N/A		
16	6000	Open Locknut Side	N/A	N/A	N/A	N/A	ALN166***	ALN166***	ALN166***	ALN166***	ASLN166***	ASLN166***	N/A	N/A	N/A	N/A	N/A	
		Open Non Locknut Side	N/A	N/A	N/A	N/A	A166***	A166***	A166***	A166***	AS166***	AS166***	N/A	N/A	N/A	N/A	N/A	
		Closed Locknut Side	N/A	N/A	N/A	N/A	BLN166000	BLN166000	BLN166000	BLN166000	BSLN166000	BSLN166000	N/A	N/A	N/A	N/A	N/A	
		Closed Non Locknut Side	N/A	N/A	N/A	N/A	B166000	BS166000	B166000	BS166000	BS166000	BS166000	N/A	N/A	N/A	N/A	N/A	
9000	Open	N/A	N/A	N/A	N/A	A16***	AS16***	A16***	AS16***	N/A	N/A	N/A	N/A	N/A	N/A	N/A		
	Closed	N/A	N/A	N/A	N/A	B16	BS16	B16	BS16	N/A	N/A	N/A	N/A	N/A	N/A	N/A		

‡ Housings are not drilled to accept auxiliary caps as standard.

*** Indicates shaft size in inches, i.e. the open cap for a ZA2107 would be A4107

◊ See specific product page for applicability.

Auxiliary Cap Kit Part Number by Housing Style ‡ (Continued)

Size Code	Series	Aux Cap Style	HousingType												
			ZFS ◊	ZEF	ZBR	ZCS	ZMC	ZT	ZN	ZHT	ZST	ZAT ◊	ZFT	ZGT	ZNT
2	2000	Open	N/A	N/A	N/A	N/A	N/A	N/A	N/A	N/A	N/A	N/A	N/A	N/A	N/A
		Closed	N/A	N/A	N/A	N/A	N/A	N/A	N/A	N/A	N/A	N/A	N/A	N/A	N/A
3	2000	Open	N/A	N/A	N/A	N/A	N/A	N/A	N/A	N/A	N/A	N/A	N/A	N/A	N/A
		Closed	N/A	N/A	N/A	N/A	N/A	N/A	N/A	N/A	N/A	N/A	N/A	N/A	N/A
4	2000	Open	AS4***	A4***	A4***	N/A	N/A	A4***	N/A	N/A	N/A	A4***	A4***	N/A	N/A
		Closed	BS4	B4	B4	N/A	N/A	B4	N/A	N/A	N/A	B4	B4	N/A	N/A
	3000	Open	AS4***	A4***	A4***	N/A	N/A	A4***	N/A	N/A	N/A	A4***	A4***	N/A	N/A
		Closed	BS4	B4	B4	N/A	N/A	B4	N/A	N/A	N/A	B4	B4	N/A	N/A
	5000	Open	AS4***	A4***	A4***	N/A	N/A	A4***	N/A	N/A	N/A	A4***	A4***	N/A	N/A
		Closed	BS4	B4	B4	N/A	N/A	B4	N/A	N/A	N/A	B4	B4	N/A	N/A
6000	Open	N/A	N/A	N/A	N/A	N/A	N/A	N/A	N/A	N/A	N/A	N/A	N/A	N/A	
	Closed	N/A	N/A	N/A	N/A	N/A	N/A	N/A	N/A	N/A	N/A	N/A	N/A	N/A	
5	2000	Open	AS5***	A5***	A5***	N/A	N/A	A5***	N/A	A5***	A5***	A5***	A5***	N/A	N/A
		Closed	BS5	B5	B5	N/A	N/A	B5	N/A	B5	B5	B5	B5	N/A	N/A
	3000	Open	AS5***	A5***	A5***	N/A	N/A	A5***	N/A	A5***	A5***	A5***	A5***	N/A	N/A
		Closed	BS5	B5	B5	N/A	N/A	B5	N/A	B5	B5	B5	B5	N/A	N/A
	5000	Open	AS5***	A5***	A5***	N/A	N/A	A5***	N/A	A5***	A5***	A5***	A5***	N/A	N/A
		Closed	BS5	B5	B5	N/A	N/A	B5	N/A	B5	B5	B5	B5	N/A	N/A
6000	Open	N/A	N/A	N/A	N/A	N/A	N/A	N/A	N/A	N/A	N/A	N/A	N/A	N/A	
	Closed	N/A	N/A	N/A	N/A	N/A	N/A	N/A	N/A	N/A	N/A	N/A	N/A	N/A	
6	2000	Open	AS6***	A6***	A6***	N/A	N/A	A6***	A6***	A6***	A6***	A6***	A6***	A6***	A6***
		Closed	BS6	B6	B6	N/A	N/A	B6	B6	B6	B6	B6	B6	B6	B6
	3000	Open	AS6***	A6***	A6***	N/A	N/A	A6***	A6***	A6***	A6***	A6***	A6***	A6***	A6***
		Closed	BS6	B6	B6	N/A	N/A	B6	B6	B6	B6	B6	B6	B6	B6
	5000	Open	AS6***	A6***	A6***	N/A	N/A	A6***	A6***	A6***	A6***	A6***	A6***	A6***	A6***
		Closed	BS6	B6	B6	N/A	N/A	B6	B6	B6	B6	B6	B6	B6	B6
6000	Open	AS66***	A66***	A66***	N/A	N/A	A66***	A66***	A66***	A66***	A66***	A66***	A66***	A66***	
	Closed	BS66000	B66000	B66000	N/A	N/A	B66000	B66000	B66000	B66000	B66000	B66000	B66000	B66000	
7	2000	Open	AS7***	A7***	A7***	N/A	N/A	A7***	A7***	A7***	A7***	A7***	A7***	N/A	A7***
		Closed	BS7	B7	B7	N/A	N/A	B7	B7	B7	B7	B7	B7	N/A	B7
	3000	Open	AS7***	A7***	A7***	N/A	N/A	A7***	A7***	A7***	A7***	A7***	A7***	N/A	A7***
		Closed	BS7	B7	B7	N/A	N/A	B7	B7	B7	B7	B7	B7	N/A	B7
	5000	Open	AS7***	A7***	A7***	N/A	N/A	A7***	A7***	A7***	A7***	A7***	A7***	N/A	A7***
		Closed	BS7	B7	B7	N/A	N/A	B7	B7	B7	B7	B7	B7	N/A	B7
6000	Open	AS76***	A76***	A76***	N/A	N/A	A76***	A76***	A76***	A76***	A76***	A76***	N/A	A76***	
	Closed	BS76000	B76000	B76000	N/A	N/A	B76000	B76000	B76000	B76000	B76000	B76000	N/A	B76000	
8	2000	Open	AS8***	A8***	A8***	N/A	N/A	A8***	A8***	A8***	A8***	A8***	A8***	A8***	A8***
		Closed	BS8	B8	B8	N/A	N/A	B8	B8	B8	B8	B8	B8	B8	B8
	3000	Open	AS8***	A8***	A8***	N/A	N/A	A8***	A8***	A8***	A8***	A8***	A8***	A8***	A8***
		Closed	BS8	B8	B8	N/A	N/A	B8	B8	B8	B8	B8	B8	B8	B8
	5000	Open	AS8***	A8***	A8***	N/A	N/A	A8***	A8***	A8***	A8***	A8***	A8***	A8***	A8***
		Closed	BS8	B8	B8	N/A	N/A	B8	B8	B8	B8	B8	B8	B8	B8
6000	Open	AS86***	A86***	A86***	N/A	N/A	A86***	A86***	A86***	A86***	A86***	A86***	A86***	A86***	
	Closed	BS86000	B86000	B86000	N/A	N/A	B86000	B86000	B86000	B86000	B86000	B86000	B86000	B86000	
9	2000	Open	AS9***	A9***	A9***	N/A	N/A	A9***	A9***	A9***	A9***	A9***	A9***	A9***	A9***
		Closed	BS9	B9	B9	N/A	N/A	B9	B9	B9	B9	B9	B9	B9	B9
	3000	Open	AS9***	A9***	A9***	N/A	N/A	A9***	A9***	A9***	A9***	A9***	A9***	A9***	A9***
		Closed	BS9	B9	B9	N/A	N/A	B9	B9	B9	B9	B9	B9	B9	B9
	5000	Open	AS9***	A9***	A9***	N/A	N/A	A9***	A9***	A9***	A9***	A9***	A9***	A9***	A9***
		Closed	BS9	B9	B9	N/A	N/A	B9	B9	B9	B9	B9	B9	B9	B9
6000	Open	AS96***	A96***	A96***	N/A	N/A	A96***	A96***	A96***	A96***	A96***	A96***	A96***	A96***	
	Closed	BS96000	B96000	B96000	N/A	N/A	B96000	B96000	B96000	B96000	B96000	B96000	B96000	B96000	
10	2000	Open	AS10***	A10***	A10***	N/A	N/A	A10***	A10***	A10***	A10***	N/A	N/A	A10***	A10***
		Closed	BS10	B10	B10	N/A	N/A	B10	B10	B10	B10	N/A	N/A	B10	B10
	3000	Open	AS10***	A10***	A10***	N/A	N/A	A10***	A10***	A10***	A10***	N/A	N/A	A10***	A10***
		Closed	BS10	B10	B10	N/A	N/A	B10	B10	B10	B10	N/A	N/A	B10	B10
	5000	Open	AS10***	A10***	A10***	N/A	N/A	A10***	A10***	A10***	A10***	N/A	N/A	A10***	A10***
		Closed	BS10	B10	B10	N/A	N/A	B10	B10	B10	B10	N/A	N/A	B10	B10
6000	Open	AS106***	A106***	A106***	N/A	N/A	A106***	A106***	A106***	A106***	N/A	N/A	A106***	A106***	
	Closed	BS106000	B106000	B106000	N/A	N/A	B106000	B106000	B106000	B106000	N/A	N/A	B106000	B106000	
11	2000	Open	AS11***	A11***	A11***	N/A	N/A	A11***	A11***	A11***	A11***	N/A	N/A	A11***	A11***
		Closed	BS11	B11	B11	N/A	N/A	B11	B11	B11	B11	N/A	N/A	B11	B11
	3000	Open	AS11***	A11***	A11***	N/A	N/A	A11***	A11***	A11***	A11***	N/A	N/A	A11***	A11***
		Closed	BS11	B11	B11	N/A	N/A	B11	B11	B11	B11	N/A	N/A	B11	B11
	5000	Open	AS11***	A11***	A11***	N/A	N/A	A11***	A11***	A11***	A11***	N/A	N/A	A11***	A11***
		Closed	BS11	B11	B11	N/A	N/A	B11	B11	B11	B11	N/A	N/A	B11	B11
6000	Open	AS116***	A116***	A116***	N/A	N/A	A116***	A116***	A116***	A116***	N/A	N/A	A116***	A116***	
	Closed	BS116000	B116000	B116000	N/A	N/A	B116000	B116000	B116000	B116000	N/A	N/A	B116000	B116000	
9000	Open	AS11***	A11***	A11***	N/A	N/A	A11***	A11***	A11***	A11***	N/A	N/A	A11***	A11***	
	Closed	BS11	B11	B11	N/A	N/A	B11	B11	B11	B11	N/A	N/A	B11	B11	

Auxiliary Cap Kit Part Number by Housing Style ‡ (Continued)

Size Code	Series	Aux Cap Style	HousingType															
			ZFS ◊	ZEF	ZBR	ZCS	ZMC	ZT	ZN	ZHT	ZST	ZAT ◊	ZFT	ZGT	ZNT			
12	2000	Open	N/A	N/A	N/A	N/A	N/A	N/A	N/A	N/A	N/A	N/A	N/A	N/A	N/A	N/A	N/A	
		Closed	N/A	N/A	N/A	N/A	N/A	N/A	N/A	N/A	N/A	N/A	N/A	N/A	N/A	N/A	N/A	
	3000	Open	N/A	N/A	N/A	N/A	N/A	N/A	N/A	N/A	N/A	N/A	N/A	N/A	N/A	N/A	N/A	
		Closed	N/A	N/A	N/A	N/A	N/A	N/A	N/A	N/A	N/A	N/A	N/A	N/A	N/A	N/A	N/A	
	5000	Open	N/A	N/A	A12***	N/A	N/A	A12***	N/A	A12***	N/A	A12***	N/A	N/A	A12***	N/A	N/A	
		Closed	N/A	N/A	B12	N/A	N/A	B12	N/A	B12	N/A	B12	N/A	N/A	B12	N/A	N/A	
	6000	Open	N/A	N/A	A126***	N/A	N/A	A126***	N/A	A126***	N/A	A126***	N/A	N/A	A126***	N/A	N/A	
		Closed	N/A	N/A	B126000	N/A	N/A	B126000	N/A	B126000	N/A	B126000	N/A	N/A	B126000	N/A	N/A	
	9000	Open	N/A	N/A	A12***	N/A	N/A	A12***	N/A	A12***	N/A	A12***	N/A	N/A	A12***	N/A	N/A	
		Closed	N/A	N/A	B12	N/A	N/A	B12	N/A	B12	N/A	B12	N/A	N/A	B12	N/A	N/A	
	13	2000	Open	N/A	N/A	N/A	N/A	N/A	N/A	N/A	N/A	N/A	N/A	N/A	N/A	N/A	N/A	N/A
			Closed	N/A	N/A	N/A	N/A	N/A	N/A	N/A	N/A	N/A	N/A	N/A	N/A	N/A	N/A	N/A
3000		Open	N/A	N/A	N/A	N/A	N/A	N/A	N/A	N/A	N/A	N/A	N/A	N/A	N/A	N/A	N/A	N/A
		Closed	N/A	N/A	N/A	N/A	N/A	N/A	N/A	N/A	N/A	N/A	N/A	N/A	N/A	N/A	N/A	N/A
5000		Open	AS13***	N/A	A13***	N/A	N/A	A13***	N/A	A13***	N/A	A13***	N/A	N/A	A13***	N/A	N/A	
		Closed	BS13	N/A	B13	N/A	N/A	B13	N/A	B13	N/A	B13	N/A	N/A	B13	N/A	N/A	
6000		Open	AS136***	N/A	A136***	N/A	N/A	A136***	N/A	A136***	N/A	A136***	N/A	N/A	A136***	N/A	N/A	
		Closed	BS136000	N/A	B136000	N/A	N/A	B136000	N/A	B136000	N/A	B136000	N/A	N/A	B136000	N/A	N/A	
9000		Open	AS13***	N/A	A13***	N/A	N/A	A13***	N/A	A13***	N/A	A13***	N/A	N/A	A13***	N/A	N/A	
		Closed	BS13	N/A	B13	N/A	N/A	B13	N/A	B13	N/A	B13	N/A	N/A	B13	N/A	N/A	
14		2000	Open	N/A	N/A	N/A	N/A	N/A	N/A	N/A	N/A	N/A	N/A	N/A	N/A	N/A	N/A	N/A
			Closed	N/A	N/A	N/A	N/A	N/A	N/A	N/A	N/A	N/A	N/A	N/A	N/A	N/A	N/A	N/A
	3000	Open	N/A	N/A	N/A	N/A	N/A	N/A	N/A	N/A	N/A	N/A	N/A	N/A	N/A	N/A	N/A	N/A
		Closed	N/A	N/A	N/A	N/A	N/A	N/A	N/A	N/A	N/A	N/A	N/A	N/A	N/A	N/A	N/A	N/A
	5000	Open	N/A	N/A	A14***	N/A	N/A	A14***	N/A	A14***	N/A	A14***	N/A	N/A	A14***	N/A	N/A	
		Closed	N/A	N/A	B14	N/A	N/A	B14	N/A	B14	N/A	B14	N/A	N/A	B14	N/A	N/A	
	6000	Open Locknut Side	N/A	N/A	ALN146***	N/A	N/A	ALN146***	N/A	ALN146***	N/A	N/A	N/A	N/A	ALN146***	N/A	N/A	
		Open Non Locknut Side	N/A	N/A	A146***	N/A	N/A	A146***	N/A	A146***	N/A	N/A	N/A	N/A	A146***	N/A	N/A	
		Closed Locknut Side	N/A	N/A	BLN146000	N/A	N/A	BLN146000	N/A	BLN146000	N/A	N/A	N/A	N/A	BLN146000	N/A	N/A	
		Closed Non Locknut Side	N/A	N/A	B146000	N/A	N/A	B146000	N/A	B146000	N/A	N/A	N/A	N/A	B146000	N/A	N/A	
	9000	Open	N/A	N/A	A14***	N/A	N/A	A14***	N/A	A14***	N/A	N/A	N/A	N/A	A14***	N/A	N/A	
		Closed	N/A	N/A	B14	N/A	N/A	B14	N/A	B14	N/A	N/A	N/A	N/A	B14	N/A	N/A	
2000	Open	N/A	N/A	N/A	N/A	N/A	N/A	N/A	N/A	N/A	N/A	N/A	N/A	N/A	N/A	N/A	N/A	
	Closed	N/A	N/A	N/A	N/A	N/A	N/A	N/A	N/A	N/A	N/A	N/A	N/A	N/A	N/A	N/A	N/A	
3000	Open	N/A	N/A	N/A	N/A	N/A	N/A	N/A	N/A	N/A	N/A	N/A	N/A	N/A	N/A	N/A	N/A	
	Closed	N/A	N/A	N/A	N/A	N/A	N/A	N/A	N/A	N/A	N/A	N/A	N/A	N/A	N/A	N/A	N/A	
5000	Open	N/A	N/A	A15***	N/A	N/A	A15***	N/A	A15***	N/A	A15***	N/A	N/A	A15***	N/A	N/A		
	Closed	N/A	N/A	B15	N/A	N/A	B15	N/A	B15	N/A	B15	N/A	N/A	B15	N/A	N/A		
15	6000	Open Locknut Side	N/A	N/A	ALN156***	N/A	N/A	ALN156***	N/A	ALN156***	N/A	N/A	N/A	N/A	ALN156***	N/A	N/A	
		Open Non Locknut Side	N/A	N/A	A156***	N/A	N/A	A156***	N/A	A156***	N/A	N/A	N/A	N/A	A156***	N/A	N/A	
		Closed Locknut Side	N/A	N/A	BLN156000	N/A	N/A	BLN156000	N/A	BLN156000	N/A	N/A	N/A	N/A	BLN156000	N/A	N/A	
		Closed Non Locknut Side	N/A	N/A	B156000	N/A	N/A	B156000	N/A	B156000	N/A	N/A	N/A	N/A	B156000	N/A	N/A	
9000	Open	N/A	N/A	A15***	N/A	N/A	A15***	N/A	A15***	N/A	N/A	N/A	N/A	A15***	N/A	N/A		
	Closed	N/A	N/A	B15	N/A	N/A	B15	N/A	B15	N/A	N/A	N/A	N/A	B15	N/A	N/A		
2000	Open	N/A	N/A	N/A	N/A	N/A	N/A	N/A	N/A	N/A	N/A	N/A	N/A	N/A	N/A	N/A	N/A	
	Closed	N/A	N/A	N/A	N/A	N/A	N/A	N/A	N/A	N/A	N/A	N/A	N/A	N/A	N/A	N/A	N/A	
3000	Open	N/A	N/A	N/A	N/A	N/A	N/A	N/A	N/A	N/A	N/A	N/A	N/A	N/A	N/A	N/A	N/A	
	Closed	N/A	N/A	N/A	N/A	N/A	N/A	N/A	N/A	N/A	N/A	N/A	N/A	N/A	N/A	N/A	N/A	
5000	Open	N/A	N/A	A16***	N/A	N/A	A16***	N/A	A16***	N/A	A16***	N/A	N/A	A16***	N/A	N/A		
	Closed	N/A	N/A	B16	N/A	N/A	B16	N/A	B16	N/A	B16	N/A	N/A	B16	N/A	N/A		
16	6000	Open Locknut Side	N/A	N/A	ALN166***	N/A	N/A	ALN166***	N/A	ALN166***	N/A	N/A	N/A	N/A	ALN166***	N/A	N/A	
		Open Non Locknut Side	N/A	N/A	A166***	N/A	N/A	A166***	N/A	A166***	N/A	N/A	N/A	N/A	A166***	N/A	N/A	
		Closed Locknut Side	N/A	N/A	BLN166000	N/A	N/A	BLN166000	N/A	BLN166000	N/A	N/A	N/A	N/A	BLN166000	N/A	N/A	
		Closed Non Locknut Side	N/A	N/A	B166000	N/A	N/A	B166000	N/A	B166000	N/A	N/A	N/A	N/A	B166000	N/A	N/A	
9000	Open	N/A	N/A	A16***	N/A	N/A	A16***	N/A	A16***	N/A	A16***	N/A	N/A	A16***	N/A	N/A		
	Closed	N/A	N/A	B16	N/A	N/A	B16	N/A	B16	N/A	B16	N/A	N/A	B16	N/A	N/A		

‡ Housings are not drilled to accept auxiliary caps as standard.

*** Indicates shaft size in inches, i.e. the open cap for a ZA2107 would be A4107

◊ See specific product page for applicability.

ZAF5000, ZAFS5000

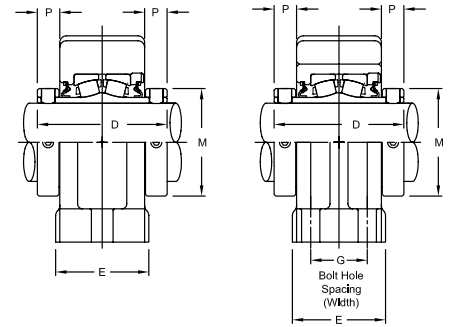
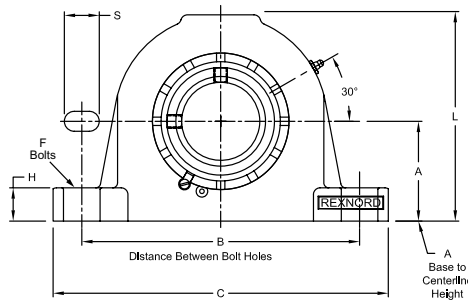
Interchange: TAF, USRB5500, (E)RPBXT



Photo Shows a 2-Bolt Spherical Roller Bearing Pillow Block Unit

Product Features

- SAF Interchange
- Precision milled ends
- Corrosion-resistant powder coating
- Cast iron housing
- Misalignment capabilities - total of 4°
- Broad range of sealing options
- Factory set clearance & lubrication
- Precision ground & superfinished raceways
- See Features and Benefits for additional info on pages 10 - 13.



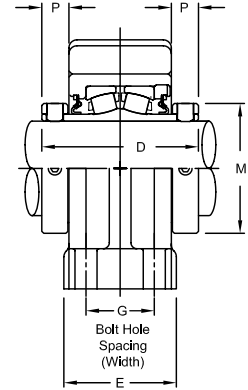
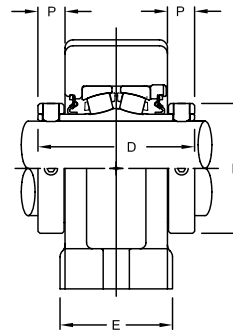
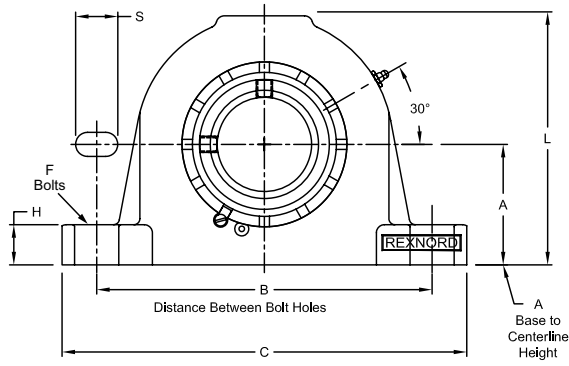
Fixed

Floating

Bearing Dimensions

Size Code	Shaft Diameter	Expansion				Fixed				A Base to Centerline Height	B Distance Between Bolt Holes		G Bolt Hole Spacing (Width)	C	D	E	F Bolts	H	M	S	
		Part Number	L	P	Approx. Weight	Part Number	L	P	Approx. Weight		Min.	Max.									
Two-Bolt Pillow Block																					
6	1 15/16	ZAFS5115	5 5/16	11/16	20.00	ZAF5115	5 5/16	11/16	16.50	2 3/4	7 3/8	7 7/8	-	9.625	3 13/16	2 3/4	5/8	1	2 7/8	15/16	
	50.00	ZAFS5050MM	134.94	17.46	9.00	ZAF5050MM	134.94	17.46	7.50	69.85	187.33	200.03	-	244.480	96.84	69.85	16.00	25.40	73.03	23.81	
7	2 3/16	ZAFS5203	5 31/32	13/16	25.50	ZAF5203	5 31/32	13/16	21.00	3	8 1/8	9 1/2	-	11.000	4 1/8	3 1/8	5/8	1	3 1/4	1 3/8	
	55.00	ZAFS5055MM	151.61	20.64	11.50	ZAF5055MM	151.61	20.64	9.50	76.20	206.38	241.30	-	279.400	104.78	79.38	16.00	25.40	82.60	34.93	
8	2 7/16	ZAFS5207	6 25/32	7/8	32.50	ZAF5207	6 25/32	7/8	32.50	3 1/4	8 5/8	9 5/8	-	11.125	4 3/8	3 1/8	5/8	1 1/4	3 9/16	1 3/16	
	60.00	ZAFS5060MM	172.24	22.23	14.70	ZAF5060MM	172.24	22.23	14.70	82.55	219.08	244.48	-	282.580	111.13	79.38	16.00	31.75	90.50	30.16	
	65.00	ZAFS5065MM	172.24	22.23	14.70	ZAF5065MM	172.24	22.23	14.70	82.55	219.08	244.48	-	282.580	111.13	79.38	16.00	31.75	90.50	30.16	
9	2 11/16	ZAFS5211	7 1/2	7/8	45.50	ZAF5211	7 1/2	7/8	45.50	3 1/2	9 7/8	11	-	12.590	4 7/8	3 1/2	3/4	1	4 1/16	1 3/8	
	2 3/4	ZAFS5212				ZAF5212															ZAF5212
	2 15/16	ZAFS5215	7 3/4	45.00	ZAF5215	7 3/4	45.00	3 3/4	-	-	-	-	-	-	-	-	-	1 1/4	-	-	
	70.00	ZAFS5070MM	190.50	22.23	20.60	ZAF5070MM	190.50	22.23	20.60	88.90	250.83	279.40	-	319.790	123.83	88.90	19.00	25.40	103.20	34.93	
85.00	ZAFS5075MM	196.85	20.40	20.40	ZAF5075MM	196.85	20.40	20.40	95.25	-	-	-	-	-	-	-	31.75	-	-	-	
10	3 3/16	ZAFS5303	8 1/4	15/16	60.00	ZAF5303	8 1/4	15/16	53.00	4	10 3/8	11 5/8	-	13.750	5 5/16	3 7/8	3/4	1 5/8	4 29/32	1 7/16	
	3 7/16	ZAFS5307	9 9/32			76.50	ZAF5307														9 9/32
	80.00	ZAFS5080MM	209.55	22.31	27.00	ZAF5080MM	209.55	23.81	24.00	101.60	263.53	295.28	-	349.250	134.94	98.43	19.00	41.28	124.62	36.51	
	85.00	ZAFS5085MM	209.55	23.81	34.70	ZAF5085MM	209.55	23.81	34.70	114.30	295.28	333.38	-	390.530	134.94	110.31	22.00	42.06	124.62	42.86	
	90.00	ZAFS5090MM	235.74	34.40	34.40	ZAF5090MM	235.74	34.40	34.40	114.30	295.28	333.38	-	390.530	134.94	110.31	22.00	42.06	124.62	42.86	
Four-Bolt Pillow Block																					
8	2 7/16	ZAFS5207F	6 25/32	7/8	31.50	ZAF5207F	6 25/32	7/8	31.00	3 1/4	8 5/8	9 5/8	1 7/8	11.125	4 3/8	3 1/8	1/2	1 1/4	3 9/16	1 1/16	
	60.00	ZAFS5060MMF	172.24	22.23	14.00	ZAF5060MMF	172.24	22.23	14.00	82.55	219.08	244.48	47.63	282.580	111.13	79.38	13.00	31.75	90.50	26.99	
	65.00	ZAFS5065MMF	172.24	22.23	14.00	ZAF5065MMF	172.24	22.23	14.00	82.55	219.08	244.48	47.63	282.580	111.13	79.38	13.00	31.75	90.50	26.99	
9	2 11/16	ZAFS5211F	7 1/2	7/8	45.50	ZAF5211F	7 1/2	7/8	45.00	3 1/2	9 7/8	11	2 1/8	12.590	4 7/8	3 1/2	5/8	1	4 1/16	1 1/4	
	2 3/4	ZAFS5212F				ZAF5212F															ZAF5212F
	2 15/16	ZAFS5215F	7 3/4	44.50	ZAF5215F	7 3/4	44.50	3 3/4	-	-	-	-	-	-	-	-	-	1 1/4	-	-	
	70.00	ZAFS5070MMF	190.50	22.23	20.60	ZAF5070MMF	190.50	22.23	20.40	88.90	250.83	279.40	53.98	319.790	123.83	88.90	16.00	25.40	103.20	31.75	
75.00	ZAFS5075MMF	196.85	20.00	20.00	ZAF5075MMF	196.85	20.00	20.00	95.25	-	-	-	-	-	-	-	31.75	-	-	-	
10	3 3/16	ZAFS5303F	8 1/4	15/16	60.00	ZAF5303F	8 1/4	15/16	53.00	4	10 3/8	11 5/8	2 1/8	13.750	5 5/16	3 7/8	5/8	1 5/8	4 29/32	1 5/16	
	3 7/16	ZAFS5307F	9 9/32			75.50	ZAF5307F														9 9/32
	80.00	ZAFS5080MMF	209.55	23.81	27.00	ZAF5080MMF	209.55	23.81	24.00	101.60	263.53	295.28	53.98	349.250	134.94	98.43	16.00	41.28	124.62	33.34	
	85.00	ZAFS5085MMF	209.55	23.81	34.00	ZAF5085MMF	209.55	23.81	34.00	114.30	295.28	333.38	60.33	390.530	134.94	110.31	19.00	42.06	124.62	39.69	
	90.00	ZAFS5090MMF	235.74	33.60	33.60	ZAF5090MMF	235.74	33.60	33.60	114.30	295.28	333.38	60.33	390.530	134.94	110.31	19.00	42.06	124.62	39.69	
11	3 15/16	ZAFS5315F	10 5/16	1 1/32	104.00	ZAF5315F	10 5/16	1 1/32	102.00	4 15/16	12 19/32	14 1/2	2 3/4	16.500	6 1/8	4 3/4	3/4	1 25/32	5 5/8	1 53/64	
	100.00	ZAFS5100MMF	261.94	47.00	47.00	ZAF5100MMF	261.94	26.19	46.00	125.41	319.86	368.30	69.85	419.100	155.58	120.65	19.00	45.24	142.90	46.43	
12	4 7/16	ZAFS5407YF	11 7/8	1 1/16	144.00	ZAF5407YF	11 7/8	1 1/16	143.00	6	14 1/2	16	3 1/4	18.375	6 1/4	5 1/8	7/8	2 1/16	6 3/16	1 3/4	
	110.00	ZAFS5110MMF	301.63	26.99	65.00	ZAF5110MMF	301.63	26.99	64.80	152.40	368.30	406.40	82.55	466.730	158.75	130.18	22.00	52.39	157.16	44.45	

Continued...



Fixed

Floating

Continued...

Bearing Dimensions

Size Code	Shaft Diameter	Expansion				Fixed				A Base to Centerline Height	B Distance Between Bolt Holes		G Bolt Hole Spacing (Width)	C	D	E	F Bolts	H	M	S
		Part Number	L	P	Approx. Weight	Part Number	L	P	Approx. Weight		Min.	Max.								
Four-Bolt Pillow Block (continued)																				
12	115.00	ZAFS5115MMF	301.63	26.99	65.00	ZAF5115MMF	301.63	26.99	64.80	152.40	368.30	406.40	82.55	466.730	158.75	130.18	22.00	52.39	157.16	44.45
	4 15/16	ZAFS5415F	12 9/16	1 5/32	209.00	ZAF5415F	12 9/16	1 5/32	207.00	6	15 5/8	17 3/8	3 3/8	19.700	7 7/8	5 7/8	1	2 1/16	7 1/16	1 15/16
13	125.00	ZAFS5125MMF	319.09	29.37	95.00	ZAF5125MMF	319.09	29.37	94.00	152.40	390.53	441.33	85.73	500.380	200.03	149.23	25.00	52.39	179.39	49.21
	130.00	ZAFS5130MMF				ZAF5130MMF														
14	5 7/16	ZAFS5507F	13 11/16	1 3/32	248.00	ZAF5507F	13 7/16	1 7/32	233.00	6 11/16	17 3/8	19 1/4	3 3/4	22.000	8	6 1/4	1	2 5/8	8 3/16	2
	140.00	ZAFS5140MMF	347.66	27.76	112.00	ZAF5140MMF	341.31	30.96	106.00	169.86	441.33	488.95	95.25	558.800	203.20	158.75	25.00	66.68	207.96	50.80
15	5 15/16	ZAFS5515F	14 9/16	1 1/16	295.00	ZAF5515F	14 1/4	1 5/32	274.00	7 1/16	19 3/8	21 5/8	4 1/4	24.750	8 1/8	6 3/4	1	2 3/4	8 5/8	2 3/16
	6	ZAFS5600F			290.00	ZAF5600F			269.00											
	150.00	ZAFS5150MMF	369.88	26.99	131.00	ZAF5150MMF	361.95	29.37	124.00	179.39	492.13	549.28	107.95	628.650	206.38	171.45	25.00	69.85	219.08	55.56
	160.00	ZAFS5160MMF				ZAF5160MMF														
16	6 7/16	ZAFS5607F	15 3/4	1 3/16	355.00	ZAF5607F	15 5/16	1 9/32	337.00	7 1/2	20 7/8	23 5/8	4 5/8	26.750	8 3/4	7 1/8	1	3	9 23/32	2 7/16
	6 1/2	ZAFS5608F			353.00	ZAF5608F	335.00													
	6 15/16	ZAFS5615F	16 1/8		376.00	ZAF5615F	15 11/16		347.00	7 7/8	21 5/8	24 3/8	4 1/2	28.000		7 1/2	1 1/4	3 1/8		2 11/16
	7	ZAFS5700F			372.00	ZAF5700F			345.00											
	180.00	ZAFS5180MMF	409.58	30.16	169.00	ZAF5180MMF	398.46	32.54	169.00	200.03	549.28	619.13	114.30	711.200	222.25	190.50	32.00	79.38	246.86	68.26

Additional Notes

- Please call 1-866-REXNORD for availability
- Metric bore sizes available, see the Rex Interchangeability guide
- Lubrication fitting tap size: for size code 6 thru 11, 1/8" PT; for all other size codes, 1/4" PT
- Base to centerline tolerance, +/- .005 in (+/- 0.13 mm)
- Bore size = nominal shaft size +.001 in/- .000 in (+0.03 mm/-0.00 mm)
- Expansion - size code 6-8 is 3/8", size code 9 thru 11 is 1/2" & size code 12 thru 16 is 3/4"
- Seals - To specify G, K or M seal, replace "Z" in part number with "G", "K" or "M"

- "K" seals only available in size codes 6 thru 11
- "G" seals available in size codes 3 thru 13
- Auxiliary end caps - available in all sizes
- Pad length tolerance, +/- .0075 in (+/- 0.19 mm) for size codes 6 thru 13, +/- .015 in (+/- 0.38 mm) for size codes 14 thru 16
- For the Selection Guide, Load Ratings and Speed Limits, see the Spherical Roller Bearings Engineering section on pages 15 - 27.
- Note: Dimensions subject to change. Certified dimensions of ordered material furnished on request.

ZAF6000, ZAFS6000

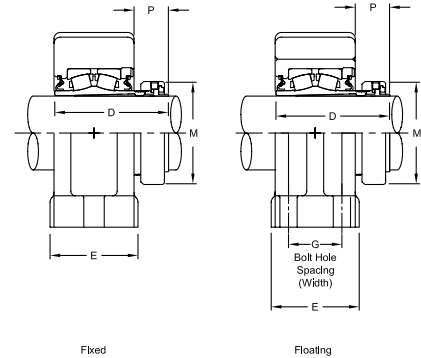
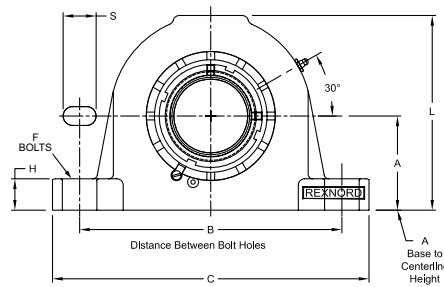
Interchange: ISAF, USRB5500A, QVVPA, QVVPH, TAPA, TAPH



Photo Shows a 2-Bolt Spherical Roller Bearing Pillow Block Unit

Product Features

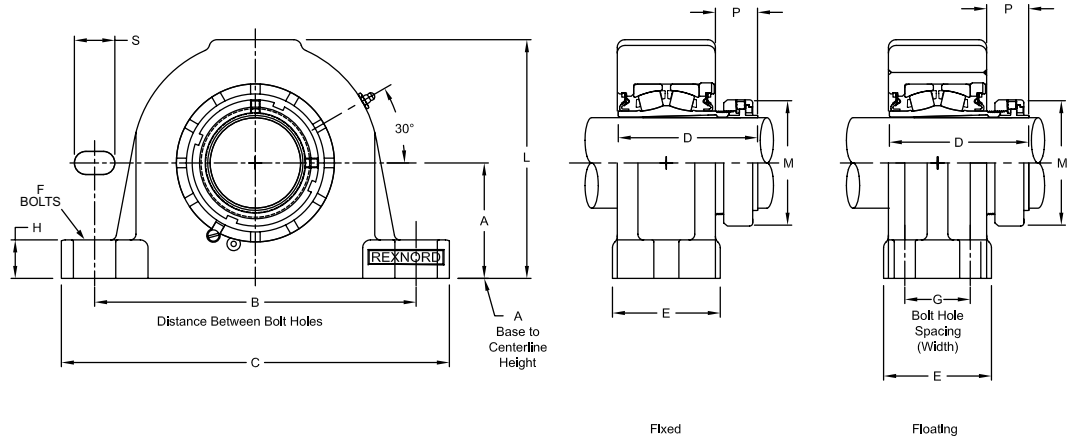
- Spyglass Optical Strain Sensor (OSS) Technology
- Positive locking system
- Tapered adapter sleeve
- SAF Interchange
- Precision milled ends
- Corrosion-resistant powder coating
- Cast iron housing
- Misalignment capabilities - total of 4°
- Broad range of sealing options
- See Features and Benefits for additional info on pages 10 - 13.



Bearing Dimensions

Size Code	Shaft Diameter	Expansion				Fixed				A Base to Centerline Height	B Distance Between Bolt Holes		G Bolt Hole Spacing (Width)	C	D	E	F Bolts	H	M	S	
		Part Number	L	P	Approx. Weight	Part Number	L	P	Approx. Weight		Min.	Max.									
Two-Bolt Pillow Block																					
6	1 5/16	ZAFS6115	5 5/16	1 1/8	20.00	ZAF6115	5 5/16	1 1/8	16.50	2 3/4	7 3/8	7 7/8	-	9.625	3 41/64	2 3/4	5/8	1	2 55/64	15/16	
		45.00	ZAFS6045MM	134.94	28.58	9.00	ZAF6045MM	134.94	28.58	7.50	69.85	187.33	200.03	-	244.480	92.47	69.85	16.00	25.40	72.63	23.81
7	2 3/16	ZAFS6203	5 31/32	1 5/32	25.50	ZAF6203	5 31/32	1 5/32	21.00	3	8 1/8	9 1/2	-	11.000	3 11/16	3 1/8	5/8	1	3 15/64	1 3/8	
		55.00	ZAFS6055MM	151.61	29.37	11.50	ZAF6055MM	151.61	29.37	9.50	76.20	206.38	241.30	-	279.400	93.66	79.38	16.00	25.40	82.15	34.93
8	2 7/16	ZAFS6206	6 25/32	1 27/64	32.50	ZAF6206	6 25/32	1 27/64	32.50	3 1/4	8 5/8	9 5/8	-	11.125	4 1/16	3 1/8	5/8	1 1/4	3 19/32	1 3/16	
		60.00	ZAFS6060MM	172.24	36.12	14.70	ZAF6060MM	172.24	36.12	14.70	82.55	219.08	244.48	-	282.580	103.19	79.38	16.00	31.75	91.28	30.16
9	2 11/16	ZAFS6211	7 1/2	1 25/64	45.00	ZAF6211	7 1/2	1 25/64	45.00	3 1/2	9 7/8	11	-	12.590	4 17/32	3 1/2	3/4	1	4 3/32	1 3/8	
		ZAF6212																			
		ZAF6215	7 3/4		3 3/4																
		70.00	ZAFS6070MM	190.50	20.60	ZAF6070MM	190.50	35.32	20.60	88.90	250.83	279.40	-	319.790	115.09	88.90	19.00	25.40	103.98	34.93	
	75.00	ZAFS6075MM	196.85	20.40	ZAF6075MM	196.85	20.40	95.25	250.83	279.40	-	-	-	-	-	-	-	-	-	-	
10	3 3/16	ZAFS6303	8 1/4	1 19/32	59.00	ZAF6303	8 1/4	1 19/32	52.00	4	10 3/8	11 5/8	-	13.750	5 1/32	3 7/8	3/4	1 5/8	4 61/64	1 7/16	
		ZAFS6307	9 9/32	1 19/32	76.50	ZAF6307	9 9/32	1 19/32	76.50	4 1/2	11 5/8	13 1/8	-	15.375	5 1/32	4 11/32	7/8	1 21/32	4 61/64	1 11/16	
		80.00	ZAFS6080MM	209.55	27.00	ZAF6080MM	209.55	40.48	24.00	101.60	263.53	295.28	-	349.250	127.79	98.43	19.00	41.28	125.81	36.51	
		85.00	ZAFS6085MM	235.74	34.70	ZAF6085MM	235.74	34.70	114.30	295.28	333.38	-	390.530	110.31	22.00	42.06					
Four-Bolt Pillow Block																					
8	2 3/8	ZAFS6206F	6 25/32	1 27/64	31.00	ZAF6206F	6 25/32	1 27/64	31.00	3 1/4	8 5/8	9 5/8	1 7/8	11.125	4 1/16	3 1/8	1/2	1 1/4	3 19/32	1 1/16	
		ZAFS6207F				ZAF6207F															
	60.00	ZAFS6060MMF	172.24	36.12	14.00	ZAF6060MMF	172.24	36.12	14.00	82.55	219.08	244.48	47.63	282.580	103.19	79.38	13.00	31.75	91.28	26.99	
9	2 11/16	ZAFS6211F	7 1/2	1 25/64	44.50	ZAF6211F	7 1/2	1 25/64	44.50	3 1/2	9 7/8	11	2 1/8	12.590	4 17/32	3 1/2	5/8	1	4 3/32	1 1/4	
		ZAFS6212F				ZAF6212F															
		ZAFS6215F	7 3/4		3 3/4																
		70.00	ZAFS6070MMF	190.50	20.60	ZAF6070MMF	190.50	35.32	20.40	88.90	250.83	279.40	53.98	319.790	115.09	88.90	16.00	25.40	103.98	31.75	
	75.00	ZAFS6075MMF	196.85	20.00	ZAF6075MMF	196.85	20.00	95.25	250.83	279.40	-	-	-	-	-	-	-	-	-	-	
10	3 3/16	ZAFS6303F	8 1/4	1 19/32	59.00	ZAF6303F	8 1/4	1 19/32	52.00	4	10 3/8	11 5/8	2 1/8	13.750	5 1/32	3 7/8	5/8	1 5/8	4 61/64	1 5/16	
		ZAFS6307F	9 9/32	1 19/32	75.00	ZAF6307F	9 9/32	1 19/32	75.00	4 1/2	11 5/8	13 1/8	2 3/8	15.375	5 1/32	4 11/32	3/4	1 21/32	4 61/64	1 9/16	
		80.00	ZAFS6080MMF	209.55	27.00	ZAF6080MMF	209.55	40.48	24.00	101.60	263.53	295.28	53.98	349.250	127.79	98.43	16.00	41.28	125.81	33.34	
		85.00	ZAFS6085MMF	235.74	34.00	ZAF6085MMF	235.74	34.00	114.30	295.28	333.38	60.33	390.530	110.31	19.00	42.06					
11	3 11/16	ZAFS6311F	10 5/16	1 47/64	103.00	ZAF6311F	10 5/16	1 47/64	103.00	4 15/16	12 19/32	14 1/2	2 3/4	16.500	5 25/32	4 3/4	3/4	1 25/32	5 43/64	1 53/64	
		ZAFS6315F				ZAF6315F															
		90.00	ZAFS6090MMF	261.94	44.05	47.00	ZAF6090MMF	261.94	44.05	46.00	125.41	319.86	368.30	69.85	419.100	146.84	120.65	19.00	45.24	144.07	46.43
		100.00	ZAFS6100MMF				ZAF6100MMF														
12	4 3/16	ZAFS6403YF	11 7/8	1 7/8	144.00	ZAF6403YF	11 7/8	1 7/8	144.00	6	14 1/2	16	3 1/4	18.375	6 1/4	5 1/8	7/8	2 1/16	6 1/16	1 3/4	
		ZAFS6407YF				ZAF6407YF															
	110.00	ZAFS6110MMF	301.63	47.63	65.00	ZAF6110MMF	301.63	47.63	64.80	152.40	368.30	406.40	82.55	466.730	158.75	130.18	22.00	52.39	153.99	44.45	

Continued...



Continued...

Bearing Dimensions

Size Code	Shaft Diameter	Expansion			Fixed			A Base to Centerline Height	B Distance Between Bolt Holes		G Bolt Hole Spacing (Width)	C	D	E	F Bolts	H	M	S		
		Part Number	L	P	Approx. Weight	Part Number	L		P	Approx. Weight									Min.	Max.
Four-Bolt Pillow Block (continued)																				
13	4 ¹⁵ / ₁₆	ZAFS6415F	12 ⁹ / ₁₆	2 ¹ / ₄	208.00	ZAF6415F	12 ⁹ / ₁₆	2 ¹ / ₄	208.00	6	15 ⁵ / ₈	17 ³ / ₈	3 ³ / ₈	19.700	7 ¹⁵ / ₁₆	5 ⁷ / ₈	1	2 ¹ / ₁₆	6 ⁶¹ / ₆₄	1 ¹⁵ / ₁₆
	125.00	ZAFS6125MMF	319.09	57.15	95.00	ZAF6125MMF	319.09	57.15	94.00	152.40	390.53	441.33	85.73	500.380	201.61	149.23	25.00	52.39	176.61	49.21
14	5 ⁷ / ₁₆	ZAFS6507F	13 ¹¹ / ₁₆	2 ¹⁵ / ₁₆	248.00	ZAF6507F	13 ⁷ / ₁₆	3 ³ / ₆₄	233.00	6 ¹¹ / ₁₆	17 ³ / ₈	19 ¹ / ₄	3 ³ / ₄	22.000	8 ⁴⁹ / ₆₄	6 ¹ / ₄	1	2 ⁵ / ₈	8 ¹ / ₆₄	2
	14 ⁹ / ₁₆	ZAFS6515F	14 ⁹ / ₁₆	3 ²³ / ₆₄	295.00	ZAF6515F	14 ¹ / ₄	3 ⁷ / ₁₆	274.00	7 ¹ / ₁₆	19 ³ / ₈	21 ⁵ / ₈	4 ¹ / ₄	24.750	9 ¹⁹ / ₆₄	6 ³ / ₄	1	2 ³ / ₄	8 ²¹ / ₃₂	2 ³ / ₁₆
15	5 ¹⁵ / ₁₆	ZAFS6607F	15 ³ / ₄	3 ³⁷ / ₆₄	355.00	ZAF6607F	15 ⁵ / ₁₆	3 ⁴³ / ₆₄	337.00	7 ¹ / ₂	20 ⁷ / ₈	23 ⁵ / ₈	4 ⁵ / ₈	26.750	10	7 ¹ / ₈	1	3	9 ³ / ₄	2 ⁷ / ₁₆
	6 ⁷ / ₁₆	ZAFS6615F	16 ¹ / ₈	3 ³⁷ / ₆₄	376.00	ZAF6615F	15 ¹¹ / ₁₆	3 ⁴³ / ₆₄	347.00	7 ⁷ / ₈	21 ⁵ / ₈	24 ³ / ₈	4 ¹ / ₂	28.000	10	7 ¹ / ₂	1 ¹ / ₄	3 ¹ / ₈	9 ³ / ₄	2 ¹¹ / ₁₆

Additional Notes

- Please call 1-866-REXNORD for availability
- Metric bore sizes available, see the Rex Interchangeability guide
- Lubrication fitting tap size: for size code 6 thru 11, 1/8" PT; for all other size codes, 1/4" PT
- Base to centerline tolerance, +/- .005 in (+/-0.13 mm)
- Expansion - size code 6-8 is 3/8", size code 9 thru 11 is 1/2" & size code 12 thru 16 is 3/4"
- Seals - To specify G, K or M seal, replace "Z" in part number with "G", "K" or "M"

- "G" seals available in size code 13
- Auxiliary end caps - available in all sizes
- Pad length tolerance, +/- .0075 in (+/-0.19 mm) for size codes 6 thru 13, +/- .015 in (+/-0.38 mm) for size codes 14 thru 16
- For the Selection Guide, Load Ratings and Speed Limits, see the Spherical Roller Bearings Engineering section on pages 15 - 27.
- Note: Dimensions subject to change. Certified dimensions of ordered material furnished on request.

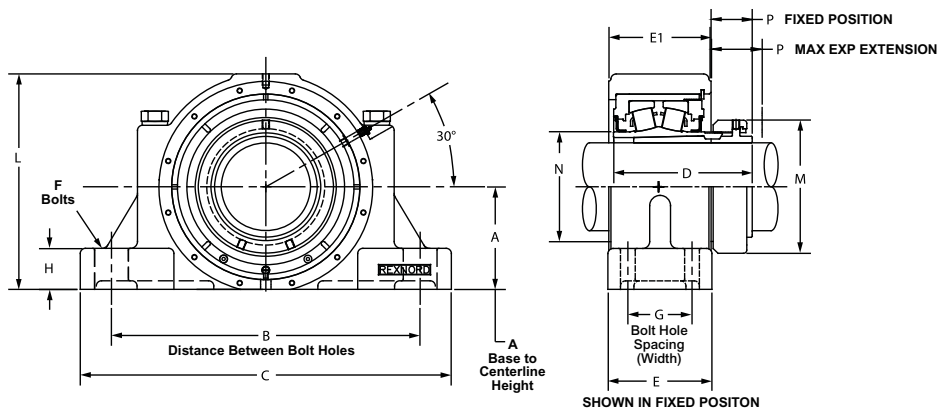
ZLF6000

Interchange: ISAF, USRB5500A, QVVPH



Product Features

- Spyglass Optical Strain Sensor (OSS) Technology
- Positive locking system
- Tapered adapter sleeve
- SAF Interchange
- Precision milled ends
- Corrosion-resistant powder coating
- Cast iron split housing
- Pre-Drilled/Tapped for Auxiliary Caps
- Unitized cartridge bearing
- Misalignment capabilities - total of 4°
- Broad range of sealing options
- See Features and Benefits for additional info on pages 10 - 13.



Bearing Dimensions

Size Code	Shaft Diameter	Expansion			Fixed			A Base to Centerline Height	B Distance Between Bolt Holes		G Bolt Hole Spacing (Width)	C	D	E	E1	F (Bolts)	H	M	N	Approx. Weight
		Part Number	L	P (Max Expansion)	Part Number	L	P		Min.	Max.										
14	5 7/16	ZLFS6507F	13 11/16	3 3/64	ZLF6507F	13 11/16	2 11/32	6 11/16	17 3/8	19 1/4	3 3/4	22	8 49/64	6 1/4	6 3/4	1	2 5/8	8 1/64	6 1/2	248
15	5 15/16	ZLFS6515F	14 9/16	3 7/16	ZLF6515F	14 9/16	2 47/64	7 1/16	19 3/8	21 5/8	4 1/4	24 3/4	9 19/64	6 3/4	7	1	2 3/4	8 21/32	7 13/64	295
16	6 7/16	ZLFS6607F	15 3/4	3 43/64	ZLF6607F	15 3/4	2 31/32	7 1/2	20 7/8	23 5/8	4 5/8	26 3/4	10	7 1/2	7 3/8	1	3	9 3/4	8 3/64	355
	6 15/16	ZLFS6615F	16 1/8	3 43/64	ZLF6615F	16 1/8	2 31/32	7 7/8	21 5/8	24 3/8	4 1/2	28	10	7 1/2	7 3/8	1 1/4	3 1/8	9 3/4	8 3/64	376

Additional Notes

- Please call 1-866-REXNORD for availability
- Lubrication fitting tap size 1/4" PT
- Base to centerline +/- .005 in (+/- 0.13 mm)
- Bore size = nominal shaft size + .001"/-.000"
- Seals - To specify M seal, replace "Z" in part number with "M"
- Auxiliary end caps - available except as noted
- Expansion - 3/4"

For the Selection Guide, Load Ratings and Speed Limits, see the Spherical Roller Bearings Engineering section on pages 15 - 27.

Note: Dimensions subject to change. Certified dimensions of ordered material furnished on request.

ZA2000, ZAS2000

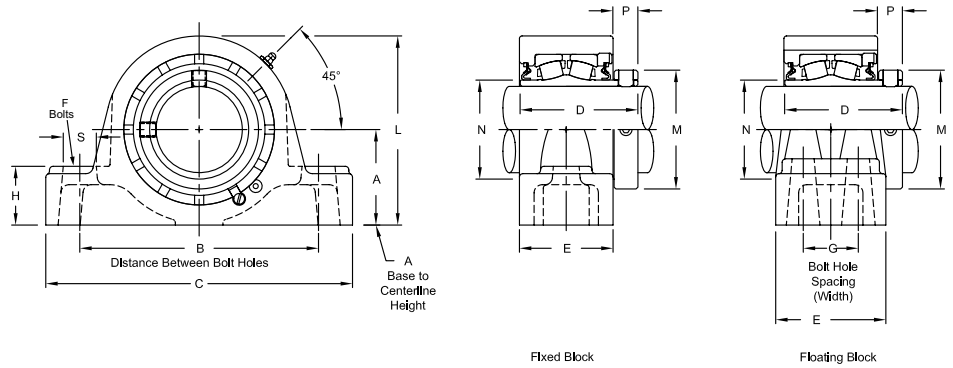
Interchange: P2BS2, P4BS2, (F)SYR, USRB5000, QAPL, QAPF



Photo Shows a 2-Bolt Spherical Roller Bearing Pillow Block Unit

Product Features

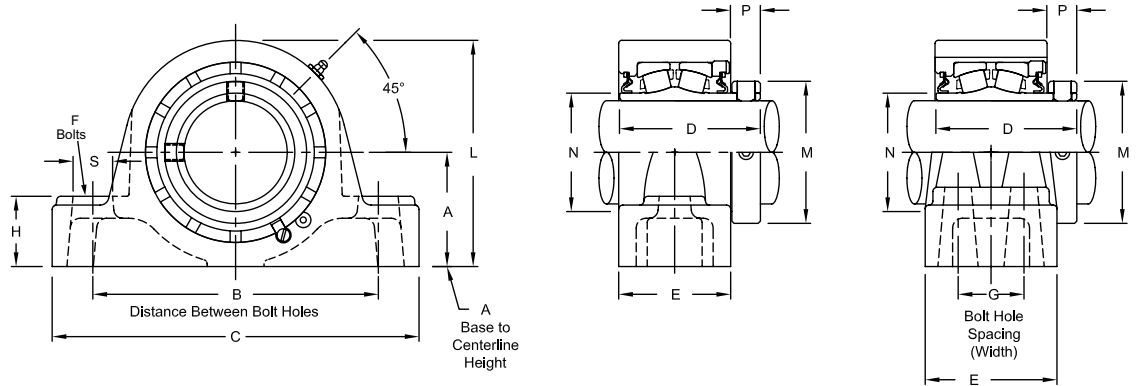
- Corrosion-resistant powder coating
- Cast iron housing
- Misalignment capabilities - total of 4°
- Broad range of sealing options
- Factory set clearance & lubrication
- Precision ground & superfinished raceways
- Hardened spring locking collar
- Field interchangeable seals
- Fixed or Expansion - total of 3/8" expansion
- See Features and Benefits for additional info on pages 10 - 13.



Bearing Dimensions

Size Code	Shaft Diameter	Expansion					Fixed					A Base to Centerline Height	B Distance Between Bolt Holes	D	F Bolts	G Bolt Hole Spacing	M	N	P	Approx. Weight		
		Part Number	C	E	H	L	S	Part Number	C	E	H										L	S
Two-Bolt Pillow Block																						
2	3/4	-	-	-	-	-	ZA2012													4.40		
	15/16	-	-	-	-	-	ZA2015	5 7/8	2	3/4	3 1/16	7/8	1 9/16	4 3/8	2 9/16	1/2	-	1 3/4	1 5/16	9/16	4.30	
	1	-	-	-	-	-	ZA2100														4.20	
	25.00	-	-	-	-	-	ZA2025MM	149.23	50.80	19.05	77.79	22.23	39.69	111.13	65.09	13.00	-	44.45	33.34	14.29	2.00	
3	1 1/8	-	-	-	-	-	ZA2102														5.50	
	1 3/16	-	-	-	-	-	ZA2103	6 5/16	2 1/8	7/8	3 7/16	7/8	1 3/4	4 3/4	2 11/16	1/2	-	2	1 17/32	9/16		
	1 1/4	-	-	-	-	-	ZA2104														5.40	
	30.00	-	-	-	-	-	ZA2030MM	160.34	53.94	22.23	87.31	22.23	44.45	120.65	68.26	13.00	-	50.00	38.89	14.29	2.50	
4	1 7/16	ZAS2107	6 9/16	2 3/16	1	3 7/8	7/8	ZA2107	6 9/16	2 1/4	1 3/16	3 11/16	13/16	1 7/8	5	2 7/8	1/2	-	2 5/16	1 3/4	11/16	7.00
	1 1/2	ZAS2108						ZA2108														6.90
		35.00	ZAS2035MM	166.96	55.56	25.40	98.42	22.23	ZA2035MM	166.96	55.56	30.16	93.66	20.64	47.63	127.00	73.02	13.00	-	58.74	44.45	17.46
5	1 11/16	ZAS2111	7 1/8	2 7/16	1	4 3/8	7/8	ZA2111	7 1/8	2 1/2	1 5/16	4 1/4	13/16	2 1/8	5 1/2	3 1/8	1/2	-	2 5/8	2 1/32	11/16	9.50
	1 3/4	ZAS2112						ZA2112														9.40
		40.00	ZAS2040MM	180.98	63.5	28.58	111.13	22.23	ZA2040MM	180.98	63.50	33.34	107.95	20.64	53.98	139.70	79.38	13.00	-	65.88	51.59	17.46
	45.00	ZAS2045MM						ZAS2045MM														4.30
6	1 15/16	ZAS2115	8 3/8	2 1/2	1 3/8	4 9/16	15/16	ZA2115	8 1/8	2 1/2	1 3/8	4 9/16	15/16	2 1/4	6 1/4	3 1/8	5/8	-	2 15/16	2 5/16	11/16	10.90
	2	ZAS2200						ZA2200														10.70
		50.00	ZAS2050MM	212.73	63.50	34.93	115.89	25.40	ZA2050MM	206.37	63.50	34.93	115.89	25.40	57.15	158.75	79.38	16.00	-	73.03	58.74	17.46
7	2 3/16	ZAS2203	8 7/8	2 9/16	1 5/8	5	15/16	ZA2203	8 5/8	2 9/16	1 5/8	5	15/16	2 1/2	6 3/4	3 5/16	5/8	-	3 1/4	2 5/8	25/32	13.50
	2 1/4	ZAS2204						ZA2204														13.30
		55.00	ZAS2055MM	225.43	65.09	41.28	127.00	25.40	ZA2055MM	219.08	65.09	41.28	127.00	25.40	63.50	171.45	84.14	16.00	-	82.60	66.68	20.64
8	2 3/8	ZAS2206						ZA2206														16.10
	2 7/16	ZAS2207	9 1/4	2 11/16	1 5/8	5 1/2	15/16	ZA2207	9 1/8	2 11/16	1 5/8	5 1/2	15/16	2 3/4	7 1/8	3 1/2	5/8	-	3 9/16	2 29/32	7/8	16.30
	2 1/2	ZAS2208						ZA2208														16.60
	60.00	ZAS2060MM	234.95	68.26	41.28	139.70	25.40	ZA2060MM	231.78	68.26	41.28	139.70	25.40	69.85	180.98	88.90	16.00	-	90.50	73.81	22.23	7.30
	65.00	ZAS2065MM						ZAS2065MM														7.60
9	2 11/16	ZAS2211						ZA2211														27.30
	2 3/4	ZAS2212	10 7/16	3 3/16	2	6 7/16	1 1/16	ZA2212	10 7/16	3 3/16	2	6 7/16	1 1/16	3 1/4	8 1/8	4	3/4	-	4 1/16	3 3/8	13/16	26.90
	2 15/16	ZAS2215						ZA2215														26.00
	70.00	ZAS2070MM	265.11	80.96	50.80	163.51	28.58	ZA2070MM	265.11	80.96	50.80	163.51	28.58	82.55	206.38	101.60	19.00	-	103.20	85.73	22.23	12.20
	75.00	ZAS2075MM						ZAS2075MM														11.00
10	3 3/16	ZAS2303						ZA2303														41.80
	3 7/16	ZAS2307	13	3 7/16	2 1/4	7 1/2	1 5/8	ZA2307	13	3 7/16	2 1/4	7 1/2	1 5/8	3 3/4	10	4 3/8	7/8	-	4 15/16	3 31/32	15/16	40.30
	3 1/2	ZAS2308						ZA2308														39.80

Continued...



Continued...

Fixed Block

Floating Block

Bearing Dimensions

Size Code	Shaft Diameter	Expansion					Fixed					A Base to Centerline Height	B Distance Between Bolt Holes	D	F Bolts	G Bolt Hole Spacing	M	N	P	Approx. Weight		
		Part Number	C	E	H	L	S	Part Number	C	E	H										L	S
Two-Bolt Pillow Block (cont.)																						
10	80.00	ZAS2080MM						ZA2080MM												19.00		
	85.00	ZAS2085MM	330.20	87.31	57.15	190.50	41.28	ZA2085MM	330.2	87.31	57.15	190.50	41.28	95.25	254.00	111.13	22.00	-	124.62	100.81	23.81	18.30
	90.00	ZAS2090MM						ZAS2090MM													18.00	
11	3 11/16	ZAS2311						ZA2311													58.00	
	3 15/16	ZAS2315	14 1/4	4 1/8	2 1/8	8 1/2	1 3/4	ZA2315	14 1/4	4 1/8	2 1/8	8 1/2	1 3/4	4 1/8	10 7/8	5 1/16	1	-	5 5/8	4 9/16	1 1/16	56.00
	4	ZAS2400						ZA2400													55.00	
	100.00	ZAS2100MM	361.95	104.78	53.98	215.90	44.45	ZA2100MM	361.95	104.78	53.98	215.90	44.45	104.78	276.23	128.59	25.00	-	142.90	115.89	26.19	25.40
Four-Bolt Pillow Block																						
6	1 15/16	ZAS2115F						ZA2115F													13.20	
	2	ZAS2200F	8 3/8	3 3/16	1 3/8	4 9/16	13/16	ZA2200F	8 3/8	3 3/16	1 3/8	4 9/16	13/16	2 1/4	6 1/4	3 1/8	1/2	1 19/32	2 15/16	2 5/16	11/16	13.10
7	50.00	ZAS2050MMF	212.73	80.96	34.93	115.89	22.23	ZA2050MMF	212.73	80.96	34.93	115.89	22.23	57.15	158.75	79.38	13.00	40.89	73.03	58.74	17.46	5.90
	2 3/16	ZAS2203F						ZA2203F														15.30
	2 1/4	ZAS2204F	8 7/8	3 1/4	1 5/8	5	13/16	ZA2204F	8 7/8	3 1/4	1 5/8	5	13/16	2 1/2	6 3/4	3 5/16	1/2	1 11/16	3 1/4	2 5/8	25/32	15.10
8	55.00	ZAS2055MMF	225.43	82.55	41.28	127.00	22.23	ZA2055MMF	225.43	82.55	41.28	127.00	22.23	63.50	171.45	84.14	13.00	42.86	82.60	66.68	20.64	7.00
	2 3/8	ZAS2206F						ZA2206F														16.90
	2 7/16	ZAS2207F	9 1/4	3 3/8	1 3/4	5 1/2	13/16	ZA2207F	9 1/4	3 3/8	1 3/4	5 1/2	13/16	2 3/4	7 1/8	3 1/2	1/2	1 3/4	3 9/16	2 29/32	7/8	16.60
	2 1/2	ZAS2208F						ZA2208F														16.40
9	60.00	ZAS2060MMF	234.95	85.73	44.45	139.70	22.23	ZA2060MMF	234.95	85.73	44.45	139.70	22.23	69.85	180.98	88.90	13.00	44.45	90.50	73.81	22.23	7.70
	65.00	ZAS2065MMF						ZA2065MMF														7.50
	2 11/16	ZAS2211F						ZA2211F														28.00
10	2 3/4	ZAS2212F	10 7/16	3 3/4	2 1/4	6 7/16	15/16	ZA2212F	10 7/16	3 3/4	2 1/4	6 7/16	15/16	3 1/4	8 1/8	4	5/8	1 7/8	4 1/16	3 3/8	13/16	27.80
	2 15/16	ZAS2215F						ZA2215F														26.80
	3	ZAS2300F						ZA2300F														26.50
	70.00	ZAS2070MMF	265.11	95.25	57.15	163.51	25.40	ZA2070MMF	265.11	95.25	57.15	163.51	25.40	82.55	206.38	101.60	16.00	47.63	103.20	85.73	22.23	12.60
	75.00	ZAS2075MMF						ZA2075MMF														12.20
11	3 3/16	ZAS2303F						ZA2303F														42.10
	3 7/16	ZAS2307F	13	4 1/8	2 1/4	7 1/2	1 1/2	ZA2307F	13	4 1/8	2 1/4	7 1/2	1 1/2	3 3/4	10	4 3/8	3/4	2	4 15/16	3 31/32	15/16	40.60
	3 1/2	ZAS2308F						ZA2308F														40.10
	80.00	ZAS2080MMF						ZA2080MMF														19.10
11	85.00	ZAS2085MMF	330.20	104.78	57.15	190.50	38.10	ZA2085MMF	330.20	104.78	57.15	190.50	38.10	95.25	254.00	111.13	19.00	50.80	124.62	100.81	23.81	18.50
	90.00	ZAS2090MMF						ZA2090MMF														18.20
	3 11/16	ZAS2311F						ZA2311F														63.00
11	3 15/16	ZAS2315F	15 1/4	4 1/2	2 5/8	8 5/8	1 1/4	ZA2315F	15 1/4	4 1/2	2 5/8	8 1/2	1 1/4	4 1/4	12 1/2	5 1/16	3/4	2 1/4	5 5/8	4 9/16	1 1/16	61.00
	4	ZAS2400F						ZA2400F														60.00
	100.00	ZAS2100MMF	387.35	114.30	66.68	215.90	31.75	ZA2100MMF	387.35	114.30	66.68	215.90	31.75	107.95	317.50	128.59	19.00	57.15	142.90	115.89	26.19	27.70

Additional Notes

- Please call 1-866-REXNORD for availability
- Metric bore sizes available, see the Rex Interchangeability guide
- Lubrication fitting tap size: 1/8" PT
- Base to centerline tolerance, +/- .005 in (+/- 0.13 mm)
- Bore size = nominal shaft size + .001 in / -.000 in (+0.03 mm / -0.00 mm)
- Expansion - is 3/8" for all size codes
- Seals - To specify G, K or M seal, replace "Z" in part number with "G", "K" or "M"

- "G" seals available in size codes 3 thru 11
- Auxiliary end caps - available in all size codes except for size codes 2 & 3 and ZAS series
- For the Selection Guide, Load Ratings and Speed Limits, see the Spherical Roller Bearings Engineering section on pages 15 - 27.
- Note: Dimensions subject to change. Certified dimensions of ordered material furnished on request.

ZA3000, ZAS3000

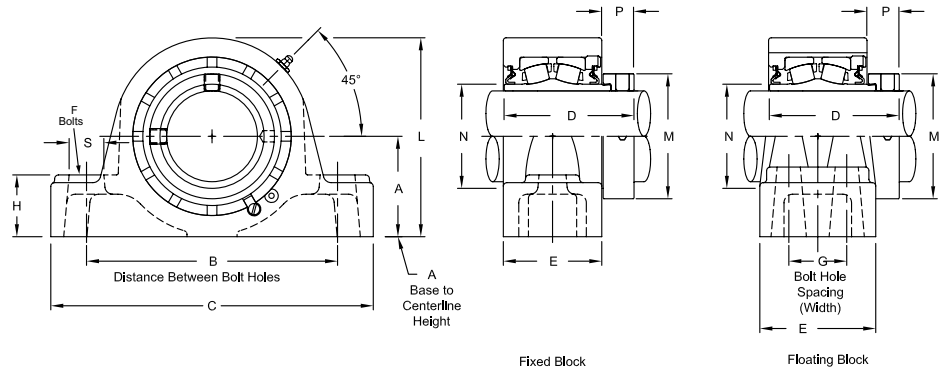
Interchange: QMPL, QMPF



Photo Shows a 2-Bolt Spherical Roller Bearing Pillow Block Unit

Product Features

- Corrosion-resistant powder coating
- Cast iron housing
- Misalignment capabilities - total of 4°
- Broad range of sealing options
- Factory set clearance & lubrication
- Precision ground & superfinished raceways
- Eccentric locking collar
- Field interchangeable seals
- Fixed or Expansion - total of 3/8" expansion
- See Features and Benefits for additional info on pages 10 - 13.



Fixed Block

Floating Block

Bearing Dimensions

Size Code	Shaft Diameter	Part Number	Expansion					Fixed					A Base to Centerline Height	B Distance Between Bolt Holes	G Bolt Hole Spacing (Width)	D	F Bolts	M	N	P	Approx. Weight	
			C	E	H	L	S	Part Number	C	E	H	L										S
Two-Bolt Pillow Block																						
4	1 7/16	ZAS3107	6 9/16	2 3/16	1	3 7/8	7/8	ZA3107	6 9/16	2 1/4	1 3/16	3 11/16	13/16	1 7/8	5	-	2 59/64	1/2	2 5/16	1 3/4	25/32	7.20
5	1 11/16	ZAS3111	7 1/8	2 7/16	1 1/8	4 3/8	7/8	ZA3111	7 1/8	2 1/2	1 5/16	4 1/4	13/16	2 1/8	5 1/2	-	3 3/16	1/2	2 5/8	2 1/32	3/4	9.70
6	1 15/16	ZAS3115	8 3/8	2 1/2	1 3/8	4 9/16	15/16	ZA3115	8 1/8	2 1/2	1 3/8	4 9/16	15/16	2 1/4	6 1/4	-	3 9/32	5/8	2 3/4	2 5/16	27/32	11.10
7	2 3/16	ZAS3203	8 7/8	2 9/16	1 5/8	5	15/16	ZA3203	8 5/8	2 9/16	1 5/8	5	15/16	2 1/2	6 3/4	-	3 1/2	5/8	3 1/4	2 5/8	31/32	13.80
8	2 7/16	ZAS3207	9 1/4	2 11/16	1 5/8	5 1/2	15/16	ZA3207	9 1/8	2 11/16	1 5/8	5 1/2	15/16	2 3/4	7 1/8	-	3 21/32	5/8	3 9/16	2 29/32	1 1/64	16.50
	ZA3208																					
9	2 11/16	ZAS3211	10 7/16	3 3/16	2	6 7/16	1 1/16	ZA3211	10 7/16	3 3/16	2	6 7/16	1 1/16	3 1/4	8 1/8	-	4 13/64	3/4	4 1/16	3 3/8	1 1/64	27.70
	ZAS3215	26.40																				
10	3 7/16	ZAS3307	13	3 7/16	2 1/4	7 1/2	1 5/8	ZA3307	13	3 7/16	2 1/4	7 1/2	1 5/8	3 3/4	10	-	4 37/64	7/8	4 15/16	3 31/32	1 9/64	40.90
	ZAS3308	40.40																				
11	3 15/16	ZAS3315	14 1/4	4 1/8	2 1/8	8 1/2	1 3/4	ZA3315	14 1/4	4 1/8	2 1/8	8 1/2	1 3/4	4 1/8	10 7/8	-	5 3/16	1	5 5/8	4 9/16	1 1/16	56.00
Four-Bolt Pillow Block																						
6	1 15/16	ZAS3115F	8 3/8	3 3/16	1 3/8	4 9/16	13/16	ZA3115F	8 3/8	3 3/16	1 3/8	4 9/16	13/16	2 1/4	6 1/4	1 19/32	3 9/32	1/2	2 3/4	2 5/16	27/32	13.40
7	2 3/16	ZAS3203F	8 7/8	3 1/4	1 5/8	5	13/16	ZA3203F	8 7/8	3 1/4	1 5/8	5	13/16	2 1/2	6 3/4	1 11/16	3 1/2	1/2	3 1/4	2 5/8	31/32	15.60
8	2 7/16	ZAS3207F	9 1/4	3 3/8	1 3/4	5 1/2	13/16	ZA3207F	9 1/4	3 3/8	1 3/4	5 1/2	13/16	2 3/4	7 1/8	1 3/4	3 21/32	1/2	3 9/16	2 29/32	1 1/64	16.80
	2 1/2	ZAS3208F						ZA3208F														
9	2 11/16	ZAS3211F	10 7/16	3 3/4	2 1/4	6 7/16	15/16	ZA3211F	10 7/16	3 3/4	2 1/4	6 7/16	15/16	3 1/4	8 1/8	1 7/8	4 13/64	5/8	4 1/16	3 3/8	1 1/64	28.40
	2 15/16	ZAS3215F						ZA3215F														
10	3 7/16	ZAS3307F	13	4 1/8	2 1/4	7 1/2	1 1/2	ZA3307F	13	4 1/8	2 1/4	7 1/2	1 1/2	3 3/4	10	2	4 37/64	3/4	4 15/16	3 31/32	1 9/64	41.20
	3 1/2	ZAS3308F						ZA3308F														
11	3 15/16	ZAS3315F	15 1/4	4 1/2	2 5/8	8 5/8	1 1/4	ZA3315F	15 1/4	4 1/2	2 5/8	8 1/2	1 1/4	4 1/4	12 1/2	2 1/4	5 3/16	3/4	5 5/8	4 9/16	1 1/16	61.00

Additional Notes

- Please call 1-866-REXNORD for availability
- Lubrication fitting tap size 1/8" PT
- Base to centerline tolerance, +/- .005 in (+/- 0.13 mm)
- Bore size = nominal shaft size +.001 in/- .000 in (+0.03 mm/-0.00 mm)
- Expansion - is 3/8" for all size codes
- Seals - To specify G, K or M seal, replace "Z" in part number with "G", "K" or "M"
- Auxiliary end caps - available in all size codes except ZAS series

For the Selection Guide, Load Ratings and Speed Limits, see the Spherical Roller Bearings Engineering section on pages 15 - 27.

Note: Dimensions subject to change. Certified dimensions of ordered material furnished on request.

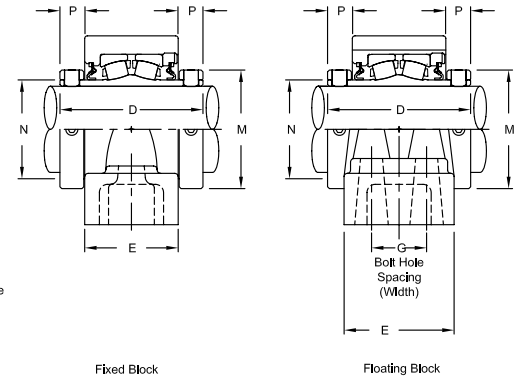
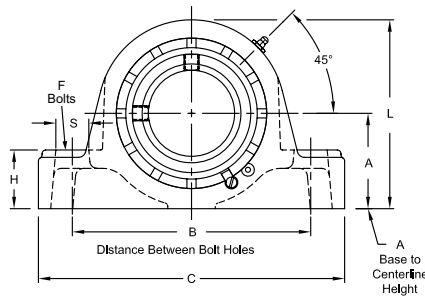
ZA5000, ZAS5000
Interchange: QAAPL, QAAPF



Photo Shows a 2-Bolt Spherical Roller Bearing Pillow Block Unit

Product Features

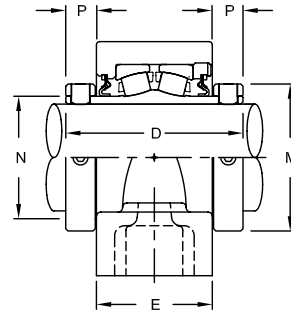
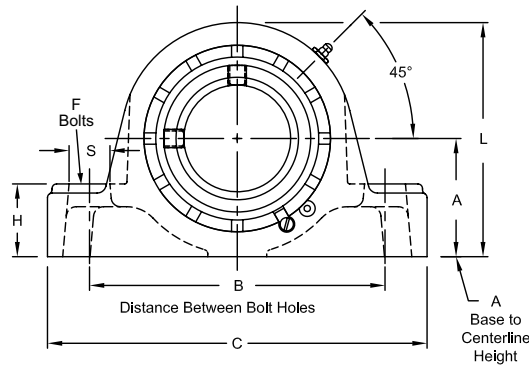
- Corrosion-resistant powder coating
- Cast iron housing
- Misalignment capabilities - total of 4°
- Broad range of sealing options
- Factory set clearance & lubrication
- Precision ground & superfinished raceways
- Two hardened spring locking collars
- Field interchangeable seals
- Fixed or Expansion - total of 3/8" expansion
- See Features and Benefits for additional info on pages 10 - 13.



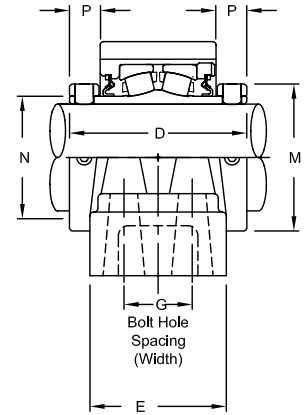
Bearing Dimensions

Size Code	Shaft Diameter	Expansion					Fixed					A Base to Centerline Height	B Distance Between Bolt Holes	D	F	G Bolt Hole Spacing (Width)	M	N	P	Approx. Weight			
		Part Number	C	E	H	L	S	Part Number	C	E	H										L	S	
Two-Bolt Pillow Block																							
4	1 7/16	ZAS5107	6 9/16	2 1/4	1 3/16	3 7/8	7/8	ZA5107	6 9/16	2 3/16	1	3 7/8	7/8	1 7/8	5	3 9/16	1/2	-	2 5/16	1 3/4	1 1/16	7.50	
	35.00	ZAS5035MM	166.96	55.56	25.40	98.42	22.23	ZA5035MM	166.96	55.56	30.16	93.66	20.64	47.63	127.00	90.49	13.00	-	58.74	44.45	17.46	3.40	
5	1 1/2	ZAS5108	7 1/8	2 1/2	1 5/16	4 3/8	7/8	ZA5108	7 1/8	2 7/16	1 1/8	4 3/8	7/8	2 1/8	5 1/2	3 13/16	1/2	-	2 19/32	2 1/32	1 1/16	10.50	
	40.00	ZAS5111						ZA5111														10.10	
	45.00	ZAS5040MM	180.98	63.5	28.58	111.13	22.23	ZA5040MM	180.98	63.50	33.34	107.95	20.64	53.98	139.70	96.84	13.00	-	65.88	51.59	17.46	4.70	
		ZAS5045MM						ZA5045MM															4.60
6	1 15/16	ZAS5115	8 3/8	2 1/2	1 3/8	4 9/16	1	ZA5115	8 3/8	2 1/2	1 3/8	4 9/16	1	2 1/4	6 1/4	3 13/16	5/8	-	2 7/8	2 5/16	1 1/16	11.50	
	50.00	ZAS5050MM	212.73	63.50	34.93	115.89	25.40	ZA5050MM	206.37	63.50	34.93	115.89	25.40	57.15	158.75	96.84	16.00	-	73.03	66.68	25.40	5.20	
7	2	ZAS5200	8 5/8	2 9/16	1 5/8	5	1	ZA5200	8 5/8	2 9/16	1 5/8	5	1	2 1/2	6 3/4	4 1/8	5/8	-	3 1/4	2 5/8	1 3/16	15.20	
		ZAS5203						ZA5203														15.80	
	55.00	ZAS5055MM	225.43	65.09	41.28	127.00	25.40	ZA5055MM	219.08	65.09	41.28	127.00	25.40	63.50	171.45	104.78	16.00		82.60	66.68	20.64	7.20	
8	2 7/16	ZAS5207	9 1/8	2 11/16	1 5/8	5 1/2	1	ZA5207	9 1/8	2 11/16	1 5/8	5 1/2	1	2 3/4	7 1/8	4 3/8	5/8	-	3 9/16	2 29/32	7/8	17.10	
	60.00	ZAS5060MM						ZA5060MM														7.80	
	65.00	ZAS5065MM	234.95	68.26	41.28	139.70	25.40	ZA5065MM	231.78	68.26	41.28	139.70	25.40	69.85	180.98	111.13	16.00	-	90.50	73.81	22.23	7.50	
		ZAS5208						ZA5208															30.00
9	2 11/16	ZAS5211	10 7/16	3 3/16	2	6 7/16	1 1/8	ZA5211	10 7/16	3 3/16	2	6 7/16	1 1/8	3 1/4	8 1/8	4 7/8	3/4	-	4 1/16	3 3/8	7/8	29.00	
		ZAS5215						ZA5215														28.50	
	70.00	ZAS5070MM	265.11	80.96	50.80	163.51	28.58	ZA5070MM	265.11	80.96	50.80	163.51	28.58	82.55	206.38	134.94	19.00	-	103.20	85.73	22.23	13.10	
	75.00	ZAS5075MM						ZA5075MM															12.90
10	3 3/16	ZAS5303	13	3 7/16	2 1/4	7 1/2	1 5/8	ZA5303	13	3 7/16	2 1/4	7 1/2	1 5/8	3 3/4	10	5 5/16	7/8	-	4 29/32	3 31/32	15/16	44.40	
		ZAS5307						ZA5307														42.50	
	80.00	ZAS5080MM						ZA5080MM															20.10
	85.00	ZAS5085MM	330.20	87.31	57.15	190.50	41.28	ZA5085MM	330.2	87.31	57.15	190.50	41.28	95.25	254.00	134.94	22.00	-	124.62	100.81	23.81	19.90	
	ZAS5090MM						ZA5090MM															19.70	
11	3 11/16	ZAS5311	14 1/4	4 1/8	2 1/8	8 1/2	1 3/4	ZA5311	14 1/4	4 1/8	2 1/8	8 1/2	1 3/4	4 1/8	10 7/8	6 1/8	1	-	5 5/8	4 9/16	1 1/32	60.50	
		ZAS5315						ZA5315														59.50	
	4	ZAS5400						ZA5400															58.50
	100.00	ZAS5100MM	361.95	104.78	53.98	215.90	44.45	ZA5100MM	361.95	104.78	53.98	215.90	44.45	104.78	276.23	155.58	25.00	-	142.90	115.89	26.19	26.50	

Continued...



Fixed Block



Floating Block

Continued...

Bearing Dimensions

Size Code	Shaft Diameter	Expansion					Fixed					A Base to Centerline Height	B Distance Between Bolt Holes	D	F Bolts	G Bolt Hole Spacing (Width)	M	N	P	Approx. Weight		
		Part Number	C	E	H	L	S	Part Number	C	E	H										L	S
Four-Bolt Pillow Block																						
6	1 15/16	ZAS5115F	8 3/8	3 3/16	1 3/8	4 9/16	7/8	ZA5115F	8 3/8	3 3/16	1 3/8	4 9/16	7/8	2 1/4	6 1/4	3 13/16	1/2	1 19/32	2 7/8	2 5/16	1 1/16	13.80
	45.00	ZAS5050MMF	212.73	80.96	34.93	115.89	22.23	ZA5050MMF	212.73	80.96	34.93	115.89	22.23	57.15	158.75	96.84	13.00	40.89	73.03	58.74	22.23	6.30
7	2	ZAS5200F	8 7/8	3 1/4	1 5/8	5	7/8	ZA5200F	8 7/8	3 1/4	1 5/8	5	7/8	2 1/2	6 3/4	4 1/8	1/2	1 11/16	3 1/4	2 5/8	1 3/16	17.00
	55.00	ZAS5203F	8 7/8	3 1/4	1 5/8	5	7/8	ZA5203F	8 7/8	3 1/4	1 5/8	5	7/8	2 1/2	6 3/4	4 1/8	1/2	1 11/16	3 1/4	2 5/8	1 3/16	17.60
8	2 7/16	ZAS5055MMF	225.43	82.55	41.28	127.00	22.23	ZA5055MMF	225.43	82.55	41.28	127.00	22.23	63.50	171.45	104.78	13.00	42.86	82.60	66.68	22.23	8.00
	60.00	ZAS5207F	9 1/4	3 3/8	1 3/4	5 1/2	7/8	ZA5207F	9 1/4	3 3/8	1 3/4	5 1/2	7/8	2 3/4	7 1/8	4 3/8	1/2	1 3/4	3 3/16	2 29/32	7/8	17.90
9	2 1/2	ZAS5060MMF	234.95	85.73	44.45	139.70	22.23	ZA5060MMF	234.95	85.73	44.45	139.70	22.23	69.85	180.98	111.13	13.00	44.45	90.50	73.81	22.23	8.10
	65.00	ZAS5065MMF	234.95	85.73	44.45	139.70	22.23	ZA5065MMF	234.95	85.73	44.45	139.70	22.23	69.85	180.98	111.13	13.00	44.45	90.50	73.81	22.23	7.80
10	2 1/2	ZAS5208F	10 7/16	3 3/4	2 1/4	6 7/16	1	ZA5208F	10 7/16	3 3/4	2 1/4	6 7/16	1	3 1/4	8 1/8	4 7/8	5/8	1 7/8	4 1/16	3 3/8	7/8	30.70
	70.00	ZAS5211F	10 7/16	3 3/4	2 1/4	6 7/16	1	ZA5211F	10 7/16	3 3/4	2 1/4	6 7/16	1	3 1/4	8 1/8	4 7/8	5/8	1 7/8	4 1/16	3 3/8	7/8	29.70
11	2 15/16	ZAS5215F	10 7/16	3 3/4	2 1/4	6 7/16	1	ZA5215F	10 7/16	3 3/4	2 1/4	6 7/16	1	3 1/4	8 1/8	4 7/8	5/8	1 7/8	4 1/16	3 3/8	7/8	29.20
	75.00	ZAS5070MMF	265.11	95.25	57.15	163.51	25.40	ZA5070MMF	265.11	95.25	57.15	163.51	25.40	82.55	206.38	123.83	16.00	47.63	103.20	85.73	22.23	13.50
12	3 3/16	ZAS5075MMF	265.11	95.25	57.15	163.51	25.40	ZA5075MMF	265.11	95.25	57.15	163.51	25.40	82.55	206.38	123.83	16.00	47.63	103.20	85.73	22.23	13.20
	75.00	ZAS5303F	13	4 1/8	2 1/4	7 1/2	1 1/2	ZA5303F	13	4 1/8	2 1/4	7 1/2	1 1/2	3 3/4	10	5 5/16	3/4	2	4 29/32	3 31/32	15/16	44.70
13	3 7/16	ZAS5307F	13	4 1/8	2 1/4	7 1/2	1 1/2	ZA5307F	13	4 1/8	2 1/4	7 1/2	1 1/2	3 3/4	10	5 5/16	3/4	2	4 29/32	3 31/32	15/16	42.80
	80.00	ZAS5080MMF	330.20	104.78	57.15	190.50	38.10	ZA5080MMF	330.20	104.78	57.15	190.50	38.10	95.25	254.00	134.94	19.00	50.80	124.62	100.81	23.81	20.30
14	3 11/16	ZAS5085MMF	330.20	104.78	57.15	190.50	38.10	ZA5085MMF	330.20	104.78	57.15	190.50	38.10	95.25	254.00	134.94	19.00	50.80	124.62	100.81	23.81	20.10
	85.00	ZAS5090MMF	330.20	104.78	57.15	190.50	38.10	ZA5090MMF	330.20	104.78	57.15	190.50	38.10	95.25	254.00	134.94	19.00	50.80	124.62	100.81	23.81	19.90
15	3 15/16	ZAS5311F	15 1/4	4 1/2	2 5/8	8 1/2	1 1/4	ZA5311F	15 1/4	4 1/2	2 5/8	8 1/2	1 1/4	4 1/4	12 1/2	6 1/8	3/4	2 1/4	5 5/8	4 9/16	1 1/32	65.50
	100.00	ZAS5315F	15 1/4	4 1/2	2 5/8	8 1/2	1 1/4	ZA5315F	15 1/4	4 1/2	2 5/8	8 1/2	1 1/4	4 1/4	12 1/2	6 1/8	3/4	2 1/4	5 5/8	4 9/16	1 1/32	64.50
16	4	ZAS5400F	15 1/4	4 1/2	2 5/8	8 1/2	1 1/4	ZA5400F	15 1/4	4 1/2	2 5/8	8 1/2	1 1/4	4 1/4	12 1/2	6 1/8	3/4	2 1/4	5 5/8	4 9/16	1 1/32	63.50
	100.00	ZAS5100MMF	387.35	114.30	66.68	215.90	31.75	ZA5100MMF	387.35	114.30	66.68	215.90	31.75	107.95	317.50	155.58	19.00	57.15	142.90	115.89	26.19	28.80

Additional Notes

- Please call 1-866-REXNORD for availability
- Metric bore sizes available, see the Rex Interchangeability guide
- Lubrication fitting tap size 1/8" PT
- Base to centerline tolerance, +/- .005 in (+/- 0.13 mm)
- Bore size = nominal shaft size +.001 in/-.000 in (+0.03 mm/-0.00 mm)
- Expansion - is 3/8" for all size codes
- Seals - To specify G, K or M seal, replace "Z" in part number with "G", "K" or "M"

- Auxiliary end caps - available in all size codes except ZAS series
- For the Selection Guide, Load Ratings and Speed Limits, see the Spherical Roller Bearings Engineering section on pages 15 - 27.
- Note: Dimensions subject to change. Certified dimensions of ordered material furnished on request.

ZA6000, ZAS6000

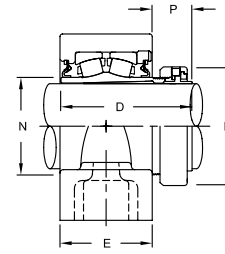
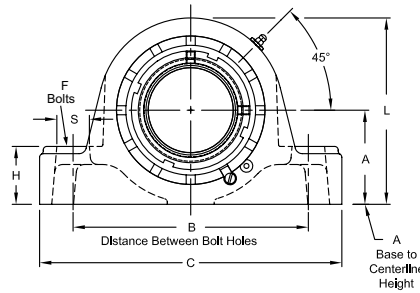
Interchange: P2BIP, P4BIP, (F)SYR-N, USRB5000A, USRBF5000A, QVVPL, QVVPF, DVVPF



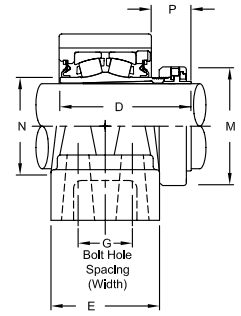
Photo Shows a 2-Bolt Spherical Roller Bearing Pillow Block Unit

Product Features

- Spyglass Optical Strain Sensor (OSS) Technology
- Positive locking system
- Tapered adapter sleeve
- Corrosion-resistant powder coating
- Cast iron housing
- Misalignment capabilities - total of 4°
- Broad range of sealing options
- Factory set clearance & lubrication
- Precision ground & superfinished raceways
- See Features and Benefits for additional info on pages 10 - 13.



Fixed Block

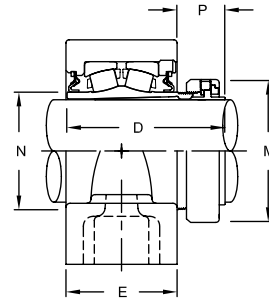
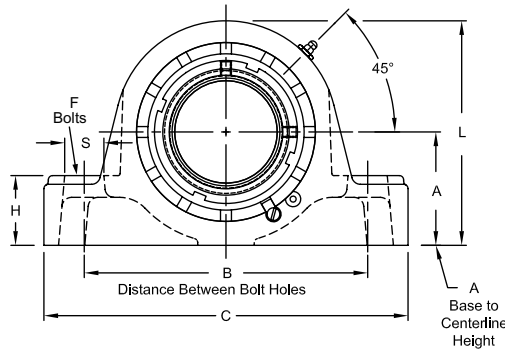


Floating Block

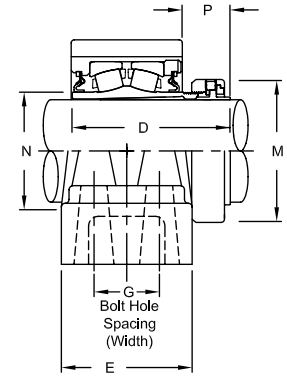
Bearing Dimensions

Size Code	Shaft Diameter	Expansion					Fixed					A Base to Centerline Height	B Distance Between Bolt Holes	G Bolt Hole Spacing (Width)	D	F Bolts	M	N	P	Approx. Weight																				
		Part Number	C	E	H	L	S	Part Number	C	E	H										L	S																		
Two-Bolt Pillow Block																																								
4	1 7/16	ZAS6107	6 9/16	2 3/16	1	3 7/8	7/8	ZA6107	6 9/16	2 1/4	1 3/16	3 11/16	13/16	1 7/8	5	-	3 21/64	1/2	2 25/64	1 3/4	1 9/64	6.10 lb																		
5	1 11/16	ZAS6111	7 1/8	2 3/16	1 1/8	4 3/8	7/8	ZA6111	7 1/8	2 1/2	1 5/16	4 1/4	13/16	2 1/8	5 1/2	-	3 47/64	1/2	2 41/64	2 1/32	1 9/32	9.50 lb																		
6	1 15/16	ZAS6115	8 3/8	2 1/2	1 3/8	4 9/16	1	ZA6115	8 1/8	2 1/2	1 3/8	4 9/16	15/16	2 1/4	6 1/4	-	3 41/64	5/8	2 55/64	2 5/16	1 1/8	10.90 lb																		
	45.00	ZAS6045MM	212.73	63.50	34.93	115.89	25.40	ZA6045MM	212.73	63.50	34.93	115.89	25.40	57.15	158.75	-	92.47	16.00	72.63	58.74	28.58	5.20 kg																		
7	2 3/16	ZAS6203	8 5/8	2 9/16	1 5/8	5	1	ZA6203	8 5/8	2 9/16	1 5/8	5	1	2 1/2	6 3/4	-	3 11/16	5/8	3 15/64	2 5/8	1 5/32	12.90 lb																		
	55.00	ZAS6055MM	225.43	65.09	41.28	127.00	25.40	ZA6055MM	225.43	65.09	41.28	127.00	25.40	63.50	171.45	-	93.66	16.00	82.15	66.68	29.37	7.20 kg																		
8	2 3/8	ZAS6206	9 1/8	2 11/16	1 5/8	5 1/2	1	ZA6206	9 1/8	2 11/16	1 5/8	5 1/2	1	2 3/4	7 1/8	-	4 1/16	5/8	3 19/32	2 29/32	1 27/64	16.10 lb																		
	2 7/16	ZAS6207						ZA6207														16.30 lb																		
	60.00	ZAS6060MM						231.78														68.26	41.28	139.70	25.40	ZA6060MM	231.78	68.26	41.28	139.70	25.40	69.85	180.98	-	103.19	16.00	91.28	73.81	36.12	7.80 kg
9	2 11/16	ZAS6211	10 7/16	3 3/16	2	6 7/16	1 1/8	ZA6211	10 7/16	3 3/16	2	6 7/16	1 1/8	3 1/4	8 1/8	-	4 17/32	3/4	4 3/32	3 3/8	1 25/64	27.30 lb																		
	2 3/4	ZAS6212						ZA6212														26.90 lb																		
	2 15/16	ZAS6215						ZA6215														26.00 lb																		
	70.00	ZAS6070MM						265.11														80.96	50.80	163.51	28.58	ZA6070MM	265.11	80.96	50.80	163.51	28.58	82.55	206.38	-	115.09	19.00	103.98	85.73	35.32	13.10 kg
	75.00	ZAS6075MM						265.11														80.96	50.80	163.51	28.58	ZA6075MM	265.11	80.96	50.80	163.51	28.58	82.55	206.38	-	115.09	19.00	103.98	85.73	35.32	12.90 kg
10	3 3/16	ZAS6303	13	3 7/16	2 1/4	7 1/2	1 5/8	ZA6303	13	3 7/16	2 1/4	7 1/2	1 5/8	3 3/4	10	-	5 1/32	7/8	4 61/64	3 31/32	1 19/32	41.80 lb																		
	3 7/16	ZAS6307						ZA6307														40.30 lb																		
	80.00	ZAS6080MM						330.20														87.31	57.15	190.50	41.28	ZA6080MM	330.2	87.31	57.15	190.50	41.28	95.25	254.00	-	127.79	22.00	125.81	100.81	40.48	20.10 kg
	85.00	ZAS6085MM						330.20														87.31	57.15	190.50	41.28	ZA6085MM	330.2	87.31	57.15	190.50	41.28	95.25	254.00	-	127.79	22.00	125.81	100.81	40.48	19.90 kg
11	3 11/16	ZAS6311	14 1/4	4 1/8	2 1/8	8 1/2	1 3/4	ZA6311	14 1/4	4 1/8	2 1/8	8 1/2	1 3/4	4 1/8	10 7/8	-	5 31/32	1	5 43/64	4 9/16	1 47/64	58.00 lb																		
	3 15/16	ZAS6315						ZA6315														56.00 lb																		
	90.00	ZAS6090MM						361.95														104.78	53.98	215.90	44.45	ZA6090MM	361.95	104.78	53.98	215.90	44.45	104.78	276.23	-	146.84	25.00	144.07	115.89	44.05	26.50 kg
	100.00	ZAS6100MM						361.95														104.78	53.98	215.90	44.45	ZA6100MM	361.95	104.78	53.98	215.90	44.45	104.78	276.23	-	146.84	25.00	144.07	115.89	44.05	26.50 kg
Four-Bolt Pillow Block																																								
6	1 15/16	ZAS6115F	8 3/8	3 3/16	1 3/8	4 9/16	7/8	ZA6115F	8 3/8	3 3/16	1 3/8	4 9/16	7/8	2 1/4	6 1/4	1 19/32	3 41/64	1/2	2 55/64	2 5/16	1 1/8	11.70 lb																		
	45.00	ZAS6045MMF	212.73	80.96	34.93	115.89	22.23	ZA6045MMF	212.73	80.96	34.93	115.89	22.23	57.15	158.75	40.89	92.47	13.00	72.63	58.74	28.58	6.30 kg																		
7	2 3/16	ZAS6203F	8 7/8	3 1/4	1 5/8	5	7/8	ZA6203F	8 7/8	3 1/4	1 5/8	5	7/8	2 1/2	6 3/4	1 11/16	3 11/16	1/2	3 15/64	2 5/8	1 5/32	15.30 lb																		
	55.00	ZAS6055MMF	225.43	82.55	41.28	127.00	22.23	ZA6055MMF	225.43	82.55	41.28	127.00	22.23	63.50	171.45	42.86	93.66	13.00	82.15	66.68	29.37	8.00 kg																		
8	2 3/8	ZAS6206F	9 1/4	3 3/8	1 3/4	5 1/2	7/8	ZA6206F	9 1/4	3 3/8	1 3/4	5 1/2	7/8	2 3/4	7 1/8	1 3/4	4 1/16	1/2	3 19/32	2 29/32	1 27/64	16.90 lb																		
	2 7/16	ZAS6207F						ZA6207F														16.60 lb																		
60.00	ZAS6060MMF	234.95	85.73	44.45	139.70	22.23	ZA6060MMF	234.95	85.73	44.45	139.70	22.23	69.85	180.98	44.45	103.19	13.00	91.28	73.81	36.12	8.10 kg																			
9	2 11/16	ZAS6211F	10 7/16	3 3/4	2 1/4	6 7/16	1	ZA6211F	10 7/16	3 3/4	2 1/4	6 7/16	1	3 1/4	8 1/8	1 7/8	4 17/32	5/8	4 3/32	3 3/8	1 25/64	28.00 lb																		
	2 3/4	ZAS6212F						ZA6212F														26.80 lb																		
	2 15/16	ZAS6215F						ZA6215F														26.80 lb																		
	70.00	ZAS6070MMF						165.11														95.25	57.15	163.51	25.40	ZA6070MMF	165.11	95.25	57.15	163.51	25.40	82.55	206.38	47.63	115.09	16.00	103.98	85.73	35.32	13.50 kg
75.00	ZAS6075MMF	165.11	95.25	57.15	163.51	25.40	ZA6075MMF	165.11	95.25	57.15	163.51	25.40	82.55	206.38	47.63	115.09	16.00	103.98	85.73	35.32	13.20 kg																			

Continued...



Fixed Block



Floating Block

Continued...

Bearing Dimensions

Size Code	Shaft Diameter	Expansion					Fixed					A Base to Center- line Height	B Distance Between Bolt Holes	G Bolt Hole Spacing (Width)	D	F Bolts	M	N	P	Approx. Weight		
		Part Number	C	E	H	L	S	Part Number	C	E	H										L	S
Four-Bolt Pillow Block																						
10	3 3/16	ZAS6303F	13	4 1/8	2 1/4	7 1/2	1 1/2	ZA6303F	13	4 1/8	2 1/4	7 1/2	1 1/2	3 3/4	10	2	5 1/32	3/4	4 61/64	3 31/32	1 19/32	42.10 lb
	3 7/16	ZAS6307F						ZA6307F														40.60 lb
	80.00	ZAS6080MMF	330.20	104.78	57.15	190.50	38.10	ZA6080MMF	330.20	104.78	57.15	190.50	38.10	95.25	254.00	50.80	127.79	19.00	125.81	100.81	40.48	20.30 kg
	85.00	ZAS6085MMF						ZA6085MMF														
11	3 11/16	ZAS6311F	15 1/4	4 1/2	2 5/8	8 1/2	1 1/4	ZA6311F	15 1/4	4 1/2	2 5/8	8 1/2	1 1/4	4 1/4	12 1/2	2 1/4	5 31/32	3/4	5 43/64	4 9/16	1 47/64	63.00 lb
	3 15/16	ZAS6315F						ZA6315F														61.00 lb
	90.00	ZAS6090MMF	387.35	114.30	66.68	215.90	31.75	ZA6090MMF	387.35	114.30	66.68	215.90	31.75	107.95	317.50	57.15	146.84	19.00	144.07	115.89	44.05	28.80 kg
	100.00	ZAS6100MMF						ZA6100MMF														

Additional Notes

- Please call 1-866-REXNORD for availability
- Metric bore sizes available, see the Rex Interchangeability guide
- Lubrication fitting tap size: for fixed units 1/8" PT
- Base to centerline tolerance, +/- .005 in (+/- 0.13 mm)
- Expansion - is 3/8" for all size codes
- Seals - To specify G, K or M seal, replace "Z" in part number with "G", "K" or "M"
- Auxiliary end caps - available in all size codes except ZAS series

For the Selection Guide, Load Ratings and Speed Limits, see the Spherical Roller Bearings Engineering section on pages 15 - 27.

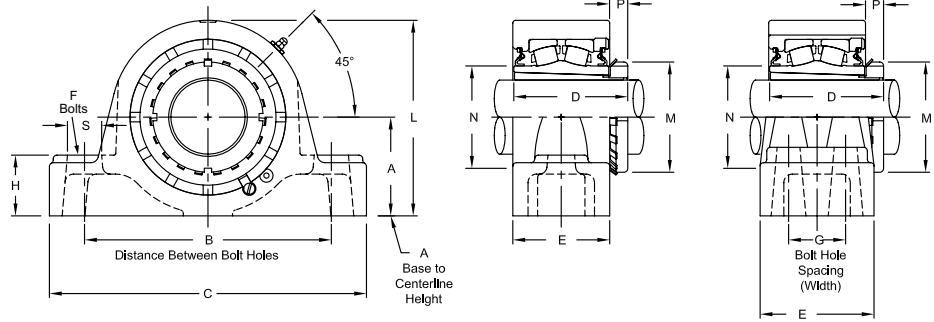
Note: Dimensions subject to change. Certified dimensions of ordered material furnished on request.



Photo Shows a 2-Bolt Spherical Roller Bearing Pillow Block Unit

Product Features

- Corrosion-resistant powder coating
- Cast iron housing
- Misalignment capabilities - total of 4°
- Broad range of sealing options
- Factory set clearance & lubrication
- Precision ground & superfinished raceways
- Enhanced life mounting style
- Field interchangeable seals
- Fixed or Expansion - total of 3/8" expansion
- See Features and Benefits for additional info on pages 10 - 13.



Fixed Block

Floating Block

Bearing Dimensions

Size Code	Shaft Diameter	Expansion		A Base to Centerline Height	B Distance Between Bolt Holes	G Bolt Hole Spacing (Width)	C	D	E	F Bolts	H	L	M	N	P	S	Approx. Weight													
		Part Number	Part Number																											
Two-Bolt Pillow Block																														
7	1 15/16	ZAS9115	ZA9115	2 1/2	6 3/4	-	8 5/8	3 3/32	2 9/16	5/8	1 5/8	5	2 31/32	2 5/8	19/32	1	13.70													
	2	ZAS9200	ZA9200														13.60													
	45.00	ZAS9045MM	ZA9045MM														63.50	171.45	-	225.43	80.17	65.09	16.00	41.28	127.00	75.40	66.680	15.08	25.40	6.10
	50.00	ZAS9050MM	ZA9050MM																											
8	2 3/16	ZAS9203	ZA9203	2 3/4	7 1/8	-	9 1/8	3 11/32	2 11/16	5/8	1 5/8	5 1/2	3 3/8	2 29/32	23/32	1	16.40													
	55.00	ZAS9055MM	ZA9055MM	69.85	180.98	-	231.78	84.93	68.26	16.00	41.28	139.70	85.73	73.810	18.26	25.40	25.40													
9	2 7/16	ZAS9207	ZA9207	3 1/4	8 1/8	-	10 7/16	3 3/4	3 3/16	3/4	2	6 7/16	3 5/8	3 3/8	5/8	1 1/8	26.60													
	2 1/2	ZAS9208	ZA9208														26.60													
10	2 11/16	ZAS9211	ZA9211	3 3/4	10	-	13	4 1/4	3 7/16	7/8	2 1/4	7 1/2	4 13/32	3 31/32	13/16	1 5/8	43.00													
	2 15/16	ZAS9215	ZA9215														41.80													
	75.00	ZAS9075MM	ZA9075MM														95.25	254.00	-	330.20	107.95	87.31	22.00	57.15	190.50	111.92	100.810	20.64	41.28	19.00
11	3 3/16	ZAS9303	ZA9303	4 1/8	10 7/8	-	14 1/4	5	4 1/8	1	2 1/8	8 1/2	5 3/16	5 3/16	15/16	15/16	61.00													
	3 7/16	ZAS9307	ZA9307														59.00													
	80.00	ZAS9080MM	ZA9080MM														104.78	276.23	-	361.95	127.00	104.78	25.00	53.98	215.90	131.76	115.890	23.81	44.45	27.00
Four-Bolt Pillow Block																														
7	1 15/16	ZAS9115F	ZA9115F	2 1/2	6 3/4	1 11/16	8 7/8	3 5/32	3 1/4	1/2	1 5/8	5	2 31/32	2 5/8	19/32	7/8	15.50													
	2	ZAS9200F	ZA9200F														15.40													
	45.00	ZAS9045MMF	ZA9045MMF														63.50	171.45	42.86	225.43	80.17	82.55	13.00	41.28	127.00	75.41	66.680	15.08	22.23	7.00
	50.00	ZAS9050MMF	ZA9050MMF																											
8	2 3/16	ZAS9203F	ZA9203F	2 3/4	7 1/8	1 3/4	9 1/4	3 11/32	3 3/8	1/2	1 3/4	5 1/2	3 3/8	2 29/32	23/32	7/8	17.20													
	55.00	ZAS9055MMF	ZA9055MMF	69.85	180.98	44.45	234.95	84.93	85.73	13.00	44.45	139.70	85.73	73.810	18.26	22.23	7.80													
9	2 7/16	ZAS9207F	ZA9207F	3 1/4	8 1/8	1 7/8	10 7/16	3 3/4	3 3/4	5/8	2 1/4	6 7/16	3 5/8	3 3/8	5/8	1	27.30													
	2 1/2	ZAS9208F	ZA9208F														29.30													
10	2 11/16	ZAS9211F	ZA9211F	3 3/4	10	2	13	4 1/4	4 1/4	3/4	2 1/4	7 1/2	4 13/32	3 31/32	13/16	1 1/2	43.30													
	2 15/16	ZAS9215F	ZA9215F														42.10													
	75.00	ZAS9075MMF	ZA9075MMF														95.25	254.00	50.80	330.20	107.95	104.78	19.00	57.15	190.50	111.92	100.810	20.64	38.10	19.20
11	3 3/16	ZAS9303F	ZA9303F	4 1/4	12 1/2	2 1/4	15 1/4	5	4 1/2	3/4	2 5/8	8 1/2	5 3/16	4 9/16	15/16	1 1/4	66.00													
	3 7/16	ZAS9307F	ZA9307F														64.00													
	80.00	ZAS9080MMF	ZA9080MMF														107.95	317.50	57.15	387.35	127.00	114.30	19.00	66.68	215.90	131.76	115.890	23.81	31.75	29.00

Additional Notes

- Please call 1-866-REXNORD for availability
- Lubrication fitting tap size 1/8" PT
- Base to centerline tolerance, +/-0.005 in (+/-0.13 mm)
- Expansion - is 3/8" for all size codes
- Seals - To specify G, K or M seal, replace "Z" in part number with "G", "K" or "M"
- Auxiliary end caps - available in all size codes except ZAS series

For the Selection Guide, Load Ratings and Speed Limits, see the Spherical Roller Bearings Engineering section on pages 15 - 27.
 Note: Dimensions subject to change. Certified dimensions of ordered material furnished on request.

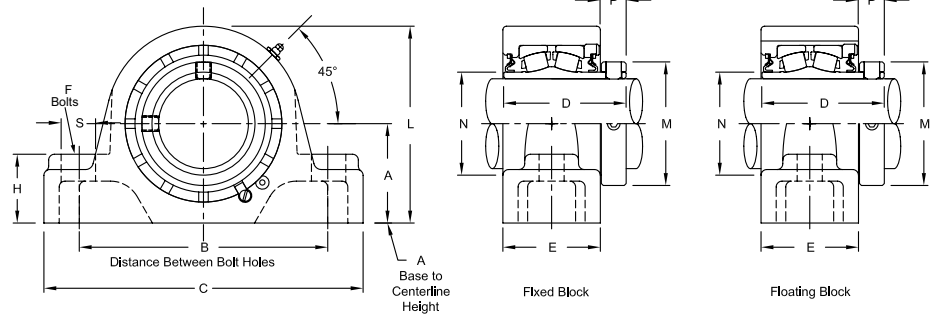
ZA2000-72, ZAS2000-72



Photo Shows a 2-Bolt Spherical Roller Bearing Pillow Block Unit

Product Features

- Corrosion-resistant powder coating
- Cast steel housing
- Misalignment capabilities - total of 4°
- Broad range of sealing options
- Factory set clearance & lubrication
- Precision ground & superfinished raceways
- Hardened spring locking collar
- Field interchangeable seals
- Fixed or Expansion - total of 3/8" expansion
- See Features and Benefits for additional info on pages 10 - 13.



Bearing Dimensions

Size Code	Shaft Diameter	Expansion				Fixed				A Base to Centerline Height	B Distance Between Bolt Holes	D	E	F Bolts	M	N	P	Approx. Weight		
		Part Number	C	H	L	S	Part Number	C	H										L	S
Two-Bolt Pillow Block																				
4	1 7/16	ZAS210772	6 9/16	1	3 7/8	7/8	ZA210772	6 9/16	1	3 5/8	7/8	1 7/8	5	2 7/8	2 1/4	1/2	2 5/16	1 3/4	1 1/16	7.50
	1 1/2	ZAS210872					ZA210872													
	35.00	ZAS2035MM72	166.69	25.40	98.43	22.23	ZA2035MM72	166.69	25.40	92.08	22.23	47.63	127.00	73.02	57.15	13.00	58.74	44.450	17.46	3.40
5	1 11/16	ZAS211172	7 1/8	1 1/8	4 3/8	7/8	ZA211172	7 1/8	1 1/8	4 3/16	7/8	2 1/8	5 1/2	3 1/8	2 1/2	1/2	2 19/32	2 1/32	1 1/16	10.50
	1 3/4	ZAS211272					ZA211272													
	40.00	ZAS2040MM72	180.98	28.58	111.13	22.23	ZA2040MM72	180.98	28.58	106.36	22.23	53.98	139.70	79.38	63.50	13.00	65.88	51.590	17.46	4.70
	45.00	ZAS2045MM72					ZA2045MM72													
6	1 15/16	ZAS211572	8 1/8	1 1/4	4 9/16	15/16	ZA211572	8 3/8	1 3/8	4 9/16	1	2 1/4	6 1/4	3 1/8	2 1/2	5/8	2 7/8	2 5/16	1 1/16	11.70
	2	ZAS220072					ZA220072													
	50.00	ZAS2050MM72	206.38	31.75	115.89	23.81	ZA2050MM72	212.73	34.93	115.89	25.40	57.15	158.75	79.38	63.50	16.00	73.03	58.740	17.46	5.30
7	2 3/16	ZAS220372	8 5/8	1 5/16	5	1	ZA220372	8 7/8	1 5/8	5	1	2 1/2	6 3/4	3 5/16	2 9/16	5/8	3 1/4	2 5/8	1 3/16	14.50
	2 1/4	ZAS220472					ZA220472													
	55.00	ZAS2055MM72	219.08	33.34	127.00	25.40	ZA2055MM72	225.43	41.28	127.00	25.40	63.50	171.45	84.14	65.09	16.00	82.60	66.680	20.64	6.60
8	2 3/8	ZAS220672					ZA220672													
	2 7/16	ZAS220772	9 1/8	1 1/2	5 1/2	1	ZA220772	9 1/4	1 3/4	5 1/2	1	2 3/4	7 1/8	3 1/2	2 11/16	5/8	3 9/16	2 29/32	7/8	18.00
	2 1/2	ZAS220872					ZA220872													
	60.00	ZAS2060MM72	231.78	38.10	139.70	25.40	ZA2060MM72	234.95	44.45	139.70	25.40	69.85	180.98	88.90	68.26	16.00	90.50	73.810	22.23	8.20
	65.00	ZAS2065MM72					ZA2065MM72													
9	2 11/16	ZAS221172					ZA221172													
	2 3/4	ZAS221272	10 7/16	1 1/8	6 7/16	1 1/8	ZA221272	10 7/16	2 1/4	6 7/16	1 1/8	3 1/4	8 1/8	4	3 3/16	3/4	4 1/16	3 3/8	7/8	25.50
	2 15/16	ZAS221572					ZA221572													
	3	ZAS230072					ZA230072													
	70.00	ZAS2070MM72	265.11	28.58	163.51	28.58	ZA2070MM72	265.11	57.15	163.51	28.58	82.55	206.38	101.60	80.96	19.00	103.20	85.730	22.23	11.60
	75.00	ZAS2075MM72					ZA2075MM72													
10	3 3/16	ZAS230372					ZA230372													
	3 7/16	ZAS230772	13	2 1/4	7 1/2	1 5/8	ZA230772	13	2 1/4	7 1/2	1 5/8	3 3/4	10	4 3/8	3 7/16	7/8	4 29/32	3 31/32	1 5/16	42.50
	3 1/2	ZAS230872					ZA230872													
	80.00	ZAS2080MM72	330.20	57.15	190.50	41.28	ZA2080MM72	330.20	57.15	190.50	41.28	95.25	254.00	111.13	87.31	22.00	124.62	100.810	23.81	19.30
	85.00	ZAS2085MM72					ZA2085MM72													
	90.00	ZAS2090MM72					ZA2090MM72													
11	3 11/16	ZAS231172					ZA231172													
	3 15/16	ZAS231572	14 1/4	2 1/8	8 1/2	1 3/4	ZA231572	14 1/4	2 1/8	8 1/2	1 3/4	4 1/8	10 7/8	5 1/16	4 1/8	1	5 5/8	4 9/16	1 1/32	52.50
	4	ZAS240072					ZA240072													
	100.00	ZAS2100MM72	361.95	53.98	215.90	44.45	ZA2100MM72	361.95	53.98	215.90	44.45	104.78	276.23	128.59	104.78	25.00	142.90	115.890	26.19	23.80

Additional Notes

- Please call 1-866-REXNORD for availability
- Metric bore sizes available, see the Rex Interchangeability guide
- Lubrication fitting tap size 1/8" PT
- Base to centerline tolerance, +/- .005 in (+/- 0.13 mm)
- Bore size = nominal shaft size +.001 in/- .000 in (+0.03 mm/-0.00 mm)
- Expansion - is 3/8" for all size codes

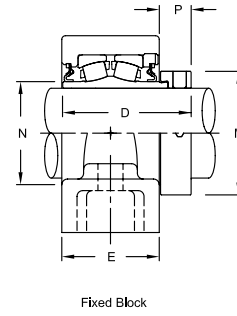
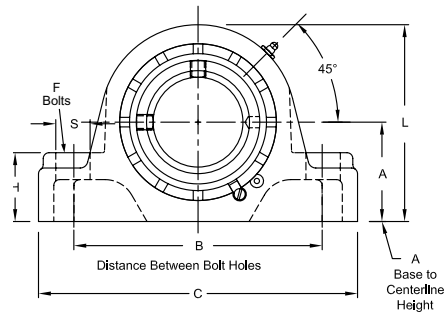
- Seals - To specify G, K or M seal, replace "Z" in part number with "G", "K" or "M"
- Auxiliary end caps - available in all size codes except ZAS series
- For the Selection Guide, Load Ratings and Speed Limits, see the Spherical Roller Bearings Engineering section on pages 15 - 27.
- Note: Dimensions subject to change. Certified dimensions of ordered material furnished on request.



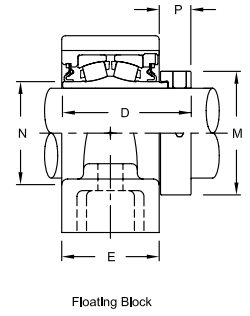
Photo Shows a 2-Bolt Spherical Roller Bearing Pillow Block Unit

Product Features

- Corrosion-resistant powder coating
- Cast steel housing
- Misalignment capabilities - total of 4°
- Broad range of sealing options
- Factory set clearance & lubrication
- Precision ground & superfinished raceways
- Eccentric locking collar
- Field interchangeable seals
- Fixed or Expansion - total of 3/8" expansion
- See Features and Benefits for additional info on pages 10 - 13.



Fixed Block



Floating Block

Bearing Dimensions

Size Code	Shaft Diameter	Expansion				Fixed				A Base to Centerline Height	B Distance Between Bolt Holes	D	E	F Bolts	M	N	P	Approx. Weight		
		Part Number	C	H	L	S	Part Number	C	H										L	S
Two-Bolt Pillow Block																				
4	1 7/16	ZAS310772	6 9/16	1	3 7/8	7/8	ZA310772	6 9/16	1	3 5/8	7/8	1 7/8	5	2 59/64	2 1/4	1/2	2 5/16	1 3/4	3/4	8.00
5	1 11/16	ZAS311172	7 1/8	1 1/8	4 3/8	7/8	ZA311172	7 1/8	1 1/8	4 3/16	7/8	2 1/8	5 1/2	3 3/16	2 1/2	1/2	2 19/32	2 1/32	3/4	10.50
6	1 15/16	ZAS311572	8 1/8	1 1/4	4 9/16	15/16	ZA311572	8 3/8	1 3/8	4 9/16	1	2 1/4	6 1/4	3 9/32	2 1/2	5/8	2 3/4	2 5/16	13/16	12.00
7	2 3/16	ZAS320372	8 5/8	1 5/16	5	1	ZA320372	8 7/8	1 5/8	5	1	2 1/2	6 3/4	3 1/2	2 9/16	5/8	3 1/4	2 5/8	31/32	15.00
8	2 7/16	ZAS320772	9 1/8	1 1/2	5 1/2	1	ZA320772	9 1/4	1 3/4	5 1/2	1	2 3/4	7 1/8	3 21/32	2 11/16	5/8	3 9/16	2 29/32	1 1/64	18.00
	ZA320872																			
9	2 11/16	ZAS321172	10 7/16	1 1/8	6 7/16	1 1/8	ZA321172	10 7/16	2 1/4	6 7/16	1 1/8	3 1/4	8 1/8	4 13/64	3 3/16	3/4	4 1/16	3 3/8	1 1/64	26.80
	ZAS321572																			
10	3 7/16	ZAS330772	13	2 1/4	7 1/2	1 5/8	ZA330772	13	2 1/4	7 1/2	1 5/8	3 3/4	10	4 9/16	3 7/16	7/8	4 29/32	3 31/32	1 9/64	42.50
	ZAS330872																			
11	3 15/16	ZAS331572	14 1/4	2 1/8	8 1/2	1 3/4	ZA331572	14 1/4	2 1/8	8 1/2	1 3/4	4 1/8	10 7/8	5 3/16	4 1/8	1	5 5/8	4 9/16	1 1/16	52.00

Additional Notes

- Please call 1-866-REXNORD for availability
- Lubrication fitting tap size 1/8" PT
- Base to centerline tolerance, +/- .005 in (**+/-0.13 mm**)
- Bore size = nominal shaft size +.001 in/-.000 in (**+0.03 mm/-0.00 mm**)
- Expansion - is 3/8" for all size codes
- Seals - To specify G, K or M seal, replace "Z" in part number with "G", "K" or "M"
- Auxiliary end caps - available in all size codes except ZAS series

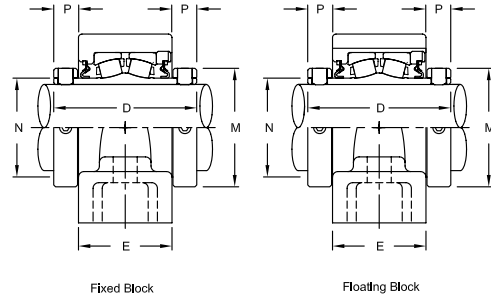
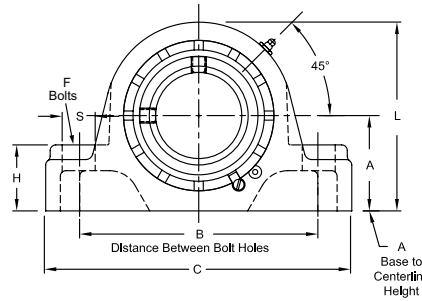
For the Selection Guide, Load Ratings and Speed Limits, see the Spherical Roller Bearings Engineering section on pages 15 - 27.

Note: Dimensions subject to change. Certified dimensions of ordered material furnished on request.

ZA5000-72, ZAS5000-72



Photo Shows a 2-Bolt Spherical Roller Bearing Pillow Block Unit



Product Features

- Corrosion-resistant powder coating
- Cast steel housing
- Misalignment capabilities - total of 4°
- Broad range of sealing options
- Factory set clearance & lubrication
- Precision ground & superfinished raceways
- Two hardened spring locking collars
- Field interchangeable seals
- Fixed or Expansion - total of 3/8" expansion
- See Features and Benefits for additional info on pages 10 - 13.

Bearing Dimensions

Size Code	Shaft Diameter	Expansion						Fixed						A Base to Centerline Height	B Distance Between Bolt Holes	D	E	F Bolts	M	N	P		
		Part Number	C	H	L	S	Approx. Weight	Part Number	C	H	L	S	Approx. Weight										
Two-Bolt Pillow Block																							
4	1 7/16	ZAS510772	6 9/16	1	3 7/8	7/8	8.50	ZA510772	6 9/16	1	3 5/8	7/8	7.30	1 7/8	5	3 9/16	2 1/4	1/2	2 5/16	1 3/4	11/16		
	35.00	ZAS5035MM72	166.69	25.40	98.43	22.23	3.90	ZAS5035MM72	166.69	25.40	92.08	22.23	3.30	47.63	127.00	90.49	57.15	13.00	58.74	44.450	17.46		
5	1 1/2	ZAS510872	7 1/8	1 1/8	4 3/8	7/8	12.10	ZAS510872	7 1/8	1 1/8	4 3/16	7/8	10.70	2 1/8	5 1/2	3 13/16	2 1/2	1/2	2 19/32	2 1/32	11/16		
	11.70	ZAS511172	40.00	ZAS5040MM72	180.98	28.58	111.13	22.23	5.50	ZAS5040MM72	180.98	28.58	106.36	22.23	4.90	53.98	139.70	96.84	63.50	13.00	65.88	51.590	17.46
	45.00	ZAS5045MM72	180.98	28.58	111.13	22.23	5.50	ZAS5045MM72	180.98	28.58	106.36	22.23	4.70	53.98	139.70	96.84	63.50	13.00	65.88	51.590	17.46		
	1 15/16	ZAS511572	8 1/8	1 1/4	4 9/16	15/16	12.80	ZAS511572	8 3/8	1 3/8	4 9/16	1	11.90	2 1/4	6 1/4	3 13/16	2 1/2	5/8	2 7/8	2 5/16	11/16		
50.00	ZAS5050MM72	206.38	31.75	115.89	23.81	5.80	ZAS5050MM72	212.73	34.93	115.89	25.40	5.40	57.15	158.75	96.84	63.50	16.00	73.03	58.740	17.46			
7	2	ZAS520072	8 5/8	1 5/16	5	1	16.50	ZAS520072	8 7/8	1 5/8	5	1	16.00	2 1/2	6 3/4	4 1/8	2 9/16	5/8	3 1/4	2 5/8	13/16		
	15.20	ZAS520372	55.00	ZAS5055MM72	219.08	33.34	127.00	25.40	7.00	ZAS5055MM72	225.43	41.28	127.00	25.40	7.00	63.50	171.45	104.78	65.09	16.00	82.60	66.680	20.64
	7.00	ZAS520772	219.08	33.34	127.00	25.40	7.00	ZAS520772	225.43	41.28	127.00	25.40	7.00	63.50	171.45	104.78	65.09	16.00	82.60	66.680	20.64		
8	2 7/16	ZAS520772	9 1/8	1 1/2	5 1/2	1	19.40	ZAS520772	9 1/4	1 3/4	5 1/2	1	18.60	2 3/4	7 1/8	4 3/8	2 11/16	5/8	3 9/16	2 29/32	7/8		
	8.80	ZAS5060MM72	231.78	38.10	139.70	25.40	8.80	ZAS5060MM72	234.95	44.45	139.70	25.40	8.50	69.85	180.98	111.13	68.26	16.00	90.50	73.810	22.23		
	8.60	ZAS5065MM72	231.78	38.10	139.70	25.40	8.60	ZAS5065MM72	234.95	44.45	139.70	25.40	8.30	69.85	180.98	111.13	68.26	16.00	90.50	73.810	22.23		
9	2 1/2	ZAS520872					29.70	ZAS520872					28.90										
	27.90	ZAS521172	10 7/16	1 1/8	6 7/16	1 1/8	28.70	ZAS521172	10 7/16	2 1/4	6 7/16	1 1/8	27.90	3 1/4	8 1/8	4 7/8	3 3/16	3/4	4 1/16	3 3/8	7/8		
	27.40	ZAS521572	70.00	ZAS5070MM72	265.11	28.58	163.51	28.58	13.00	ZAS5070MM72	265.11	57.15	163.51	28.58	13.50	82.55	206.38	123.83	80.96	19.00	103.20	85.730	22.23
	12.50	ZAS5075MM72	75.00	ZAS5075MM72	265.11	28.58	163.51	28.58	12.50	ZAS5075MM72	265.11	57.15	163.51	28.58	13.00	82.55	206.38	123.83	80.96	19.00	103.20	85.730	22.23
	13.00	ZAS530372	3 3/16	ZAS530372	46.60			46.60	ZAS530372	46.60				42.10									
10	3 7/16	ZAS530772	13	2 1/4	7 1/2	1 5/8	44.70	ZAS530772	13	2 1/4	7 1/2	1 5/8	40.20	3 3/4	10	5 5/16	3 7/16	7/8	4 29/32	3 31/32	15/16		
	42.10	ZAS5080MM72	85.00	ZAS5085MM72	330.20	57.15	190.50	41.28	21.10	ZAS5085MM72	330.20	57.15	190.50	41.28	19.00	95.25	254.00	134.94	87.31	22.00	124.62	100.810	23.81
	40.20	ZAS5090MM72	90.00	ZAS5090MM72	330.20	57.15	190.50	41.28	20.30	ZAS5090MM72	330.20	57.15	190.50	41.28	18.20	95.25	254.00	134.94	87.31	22.00	124.62	100.810	23.81
	18.20	ZAS531172	3 11/16	ZAS531172	59.50			59.50	ZAS531172	59.50				50.80									
11	3 15/16	ZAS531572	14 1/4	2 1/8	8 1/2	1 3/4	58.50	ZAS531572	14 1/4	2 1/8	8 1/2	1 3/4	49.80	4 1/8	10 7/8	6 1/8	4 1/8	1	5 5/8	4 9/16	1 1/32		
	48.80	ZAS540072	100.00	ZAS5100MM72	361.95	53.98	215.90	44.45	26.50	ZAS5100MM72	361.95	53.98	215.90	44.45	22.50	104.78	276.23	155.58	104.78	25.00	142.90	115.890	26.19
	22.50	ZAS540072	100.00	ZAS5100MM72	361.95	53.98	215.90	44.45	22.50	ZAS5100MM72	361.95	53.98	215.90	44.45	22.50	104.78	276.23	155.58	104.78	25.00	142.90	115.890	26.19

Additional Notes

- Please call 1-866-REXNORD for availability
- Metric bore sizes available, see the Rex Interchangeability guide
- Lubrication fitting tap size 1/8" PT
- Base to centerline tolerance, +/- .005 in (+/- 0.13 mm)
- Bore size = nominal shaft size +.001 in/-.000 in (+0.03 mm/-0.00 mm)
- Expansion - is 3/8" for all size codes
- Seals - To specify G, K or M seal, replace "Z" in part number with "G", "K" or "M"

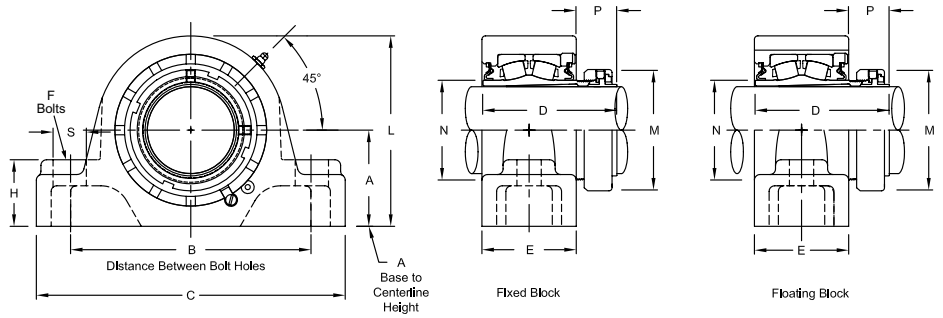
- Auxiliary end caps - available in all size codes except ZAS series
- For the Selection Guide, Load Ratings and Speed Limits, see the Spherical Roller Bearings Engineering section on pages 15 - 27.
- Note: Dimensions subject to change. Certified dimensions of ordered material furnished on request.



Photo Shows a 2-Bolt Spherical Roller Bearing Pillow Block Unit

Product Features

- Spyglass Optical Strain Sensor (OSS) Technology
- Positive locking system
- Tapered adapter sleeve
- Corrosion-resistant powder coating
- Cast steel housing
- Misalignment capabilities - total of 4°
- Broad range of sealing options
- Factory set clearance & lubrication
- Precision ground & superfinished raceways
- See Features and Benefits for additional info on pages 10 - 13.



Bearing Dimensions

Size Code	Shaft Diameter	Expansion					Fixed					A Base to Centerline Height	B Distance Between Bolt Holes	D	E	F Bolts	L	M	N	P															
		Part Number	C	H	S	Approx. Weight	Part Number	C	H	S	Approx. Weight																								
Two-Bolt Pillow Block																																			
4	1 7/16	ZAS610772	6 7/8	1 3/16	13/16	7.50	ZAS610772	6 7/8	1 3/16	13/16	7.50	1 7/8	5	3 21/64	2 1/4	1/2	3 11/16	2 25/64	1 3/4	1 9/64															
5	1 11/16	ZAS611172	7 3/8	1 5/16	13/16	9.20	ZA611172	7 3/8	1 5/16	13/16	9.20	2 1/8	5 1/2	3 47/64	2 1/2	1/2	4 3/8	2 41/64	2 1/32	1 9/32															
6	1 15/16	ZAS611572	8 1/8	1 1/4	15/16	12.20	ZA611572	8 3/8	1 3/8	1	11.30	2 1/4	6 1/4	3 41/64	2 1/2	5/8	4 9/16	2 55/64	2 5/16	1 1/8															
		45.00 ZAS6045MM72	206.38	31.75	23.81	5.80	ZA6045MM72	212.73	34.93	25.40	5.40	57.15	158.75	92.47	63.50	16.00	115.89	72.63	58.740	28.58															
7	2 3/16	ZAS620372	8 5/8	1 5/16	1	14.80	ZA620372	8 7/8	1 5/8	1	14.30	2 1/2	6 3/4	3 11/16	2 9/16	5/8	5	3 15/64	2 5/8	1 5/32															
		55.00 ZAS6055MM72	219.08	33.34	25.40	7.00	ZA6055MM72	225.43	41.28	25.40	7.00	63.50	171.45	93.66	65.09	16.00	127.00	82.15	66.680	29.37															
8	2 3/8	ZAS620672	9 1/8	1 1/2	1	18.50	ZA620672	9 1/4	1 3/4	1	17.70	2 3/4	7 1/8	4 1/16	2 11/16	5/8	5 1/2	3 19/32	2 29/32	1 27/64															
		2 7/16				ZAS620772	18.40				ZA620772										17.60														
		60.00 ZAS6060MM72				231.78	38.10				25.40										8.80	ZA6060MM72	234.95	44.45	25.40	8.50	69.85	180.98	103.19	68.26	16.00	139.70	91.28	73.810	36.12
9	2 11/16	ZAS621172	10 7/16	1 1/8	1 1/8	27.00	ZA621172	10 7/16	2 1/4	1 1/8	26.20	3 1/4	8 1/8	4 17/32	3 3/16	3/4	6 7/16	4 3/32	3 3/8	1 25/64															
		2 3/4				ZAS621272	26.60				ZA621272										25.80														
		2 15/16				ZAS621572	25.50				ZA621572										24.70														
		70.00 ZAS6070MM72				265.11	28.58				28.58										13.00	ZA6070MM72	265.11	57.15	28.58	13.50	82.55	206.38	115.09	80.96	19.00	163.51	103.98	85.730	35.32
		75.00 ZAS6075MM72				265.11	28.58				28.58										12.50	ZA6075MM72	265.11	57.15	28.58	13.00	82.55	206.38	115.09	80.96	19.00	163.51	103.98	85.730	35.32
10	3 3/16	ZAS630372	13	2 1/4	1 5/8	44.00	ZA630372	13	2 1/4	1 5/8	39.50	3 3/4	10	5 1/32	3 7/16	7/8	7 1/2	4 61/64	3 31/32	1 19/32															
		3 7/16				ZAS630772	42.50				ZA630772										41.50														
		80.00 ZAS6080MM72				330.20	57.15				41.28										21.10	ZA6080MM72	330.20	57.15	41.28	19.00	95.25	254.00	127.79	87.31	22.00	190.50	125.81	100.810	40.48
		85.00 ZAS6085MM72				330.20	57.15				41.28										21.10	ZA6085MM72	330.20	57.15	41.28	19.00	95.25	254.00	127.79	87.31	22.00	190.50	125.81	100.810	40.48
11	3 11/16	ZAS631172	14 1/4	2 1/8	1 3/4	57.00	ZA631172	14 1/4	2 1/8	1 3/4	48.30	4 1/8	10 7/8	5 25/32	4 1/8	1	8 1/2	5 43/64	4 9/16	1 47/64															
		3 15/16				ZAS631572	55.00				ZA631572										46.30														
		90.00 ZAS6090MM72				361.95	53.98				44.45										26.50	ZA6090MM72	361.95	53.98	44.45	22.50	104.78	276.23	146.84	104.78	25.00	215.90	144.07	115.890	44.05
		100.00 ZAS6100MM72				361.95	53.98				44.45										26.50	ZA6100MM72	361.95	53.98	44.45	22.50	104.78	276.23	146.84	104.78	25.00	215.90	144.07	115.890	44.05

Additional Notes

- Please call 1-866-REXNORD for availability
- Metric bore sizes available, see the Rex Interchangeability guide
- Lubrication fitting tap size 1/8" PT
- Base to centerline tolerance, +/- .005 in (+/- 0.13 mm)
- Expansion - is 3/8" for all size codes
- Seals - To specify G, K or M seal, replace "Z" in part number with "G", "K" or "M"
- Auxiliary end caps - available in all size codes except ZAS series

For the Selection Guide, Load Ratings and Speed Limits, see the Spherical Roller Bearings Engineering section on pages 15 - 27.

Note: Dimensions subject to change. Certified dimensions of ordered material furnished on request.

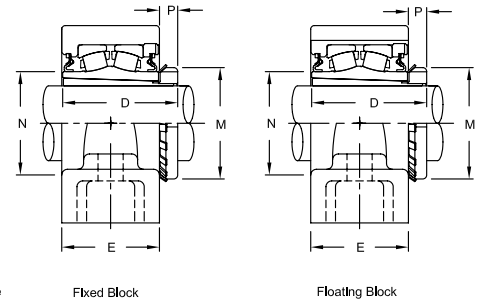
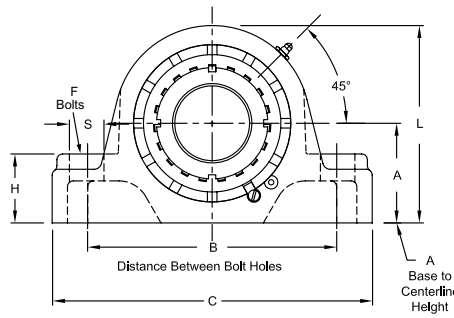
ZA9000-72, ZAS9000-72



Photo Shows a 2-Bolt Spherical Roller Bearing Pillow Block Unit

Product Features

- Corrosion-resistant powder coating
- Cast steel housing
- Misalignment capabilities - total of 4°
- Broad range of sealing options
- Factory set clearance & lubrication
- Precision ground & superfinished raceways
- Enhanced life mounting style
- Field interchangeable seals
- Fixed or Expansion - total of 3/8" expansion
- See Features and Benefits for additional info on pages 10 - 13.



Bearing Dimensions

Size Code	Shaft Diameter	Expansion				Fixed				A Base to Centerline Height	B Distance Between Bolt Holes	D	E	F Bolts	L	M	N	P	S										
		Part Number	C	H	Approx. Weight	Part Number	C	H	Approx. Weight																				
Two-Bolt Pillow Block																													
7	1 15/16	ZAS911572	8 5/8	1 5/16	15.00	ZA911572	8 7/8	1 5/8	14.50	2 1/2	6 3/4	3 5/32	2 9/16	5/8	5	2 31/32	2 5/8	19/32	1										
	2	ZAS920072			14.90	ZA920072			14.40																				
	45.00	ZAS9045MM72	219.08	33.34	6.80	ZA9045MM72	225.43	41.28	6.60											63.50	171.45	80.17	65.09	16.00	127.00	75.40	66.680	15.08	25.40
8	2 3/16	ZAS920372	9 1/8	1 1/2	18.70	ZA920372	9 1/4	1 3/4	17.90	2 3/4	7 1/8	3 11/32	2 11/16	5/8	5 1/2	3 3/8	2 29/32	23/32	1										
	55.00	ZAS9055MM72	231.78	38.10	8.50	ZA9055MM72	234.95	44.45	8.10											69.85	180.98	84.93	68.26	16.00	139.70	85.73	73.810	18.26	25.40
	2 7/16	ZAS920772	10 7/16	1 1/8	26.30	ZA920772	10 7/16	2 1/4	25.50											3 1/4	8 1/8	3 3/4	3 3/16	3/4	6 7/16	3 5/8	3 3/8	5/8	1 1/8
2 1/2	ZAS920872			25.90	ZA920872			25.10																					
2 11/16	ZAS921172	13	2 1/4	45.20	ZA921172	13	2 1/4	40.70	3 3/4	10	4 1/4	3 7/16	7/8	7 1/2	4 13/32	3 31/32	13/16	1 5/8											
10	2 15/16	ZAS921572			44.00	ZA921572			39.50	95.25	254.00	107.95	87.31	22.00	190.50	111.92	100.810	20.64	41.28										
	75.00	ZAS9075MM72	330.20	57.15	19.90	ZA9075MM72	330.20	57.15	18.00																				
	3 3/16	ZAS930372	14 1/4	2 1/8	60.00	ZA930372	14 1/4	2 1/8	51.30											4 1/8	10 7/8	5	4 1/8	1	8 1/2	5 3/16	4 9/16	15/16	1 3/4
3 7/16	ZAS930772			57.00	ZA930772			49.30																					
80.00	ZAS9080MM72	361.95	53.98	26.00	ZA9080MM72	361.95	53.98	22.30	104.78	276.23	127.00	104.78	25.00	215.90	131.76	115.890	23.81	44.45											

Additional Notes

- Please call 1-866-REXNORD for availability
- Lubrication fitting tap size 1/8" PT
- Base to centerline tolerance, +/- .005 in (+/- 0.13 mm)
- Expansion - is 3/8" for all size codes
- Seals - To specify G, K or M seal, replace "Z" in part number with "G", "K" or "M"
- Auxiliary end caps - available in all size codes except ZAS series
- For the Selection Guide, Load Ratings and Speed Limits, see the Spherical Roller Bearings Engineering section on pages 15 - 27.

Note: Dimensions subject to change. Certified dimensions of ordered material furnished on request.

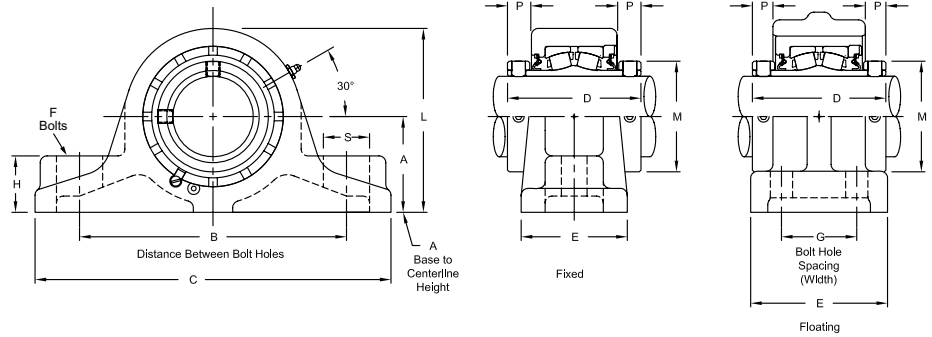
ZP5000, ZPS5000
Interchange: QAAPXT, QAAPX



Photo Shows a 2-Bolt Spherical Roller Bearing Pillow Block Unit

Product Features

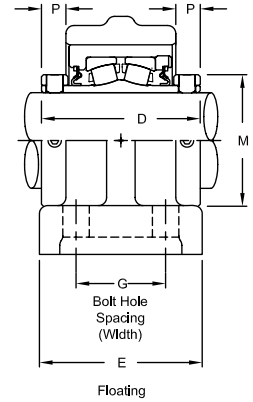
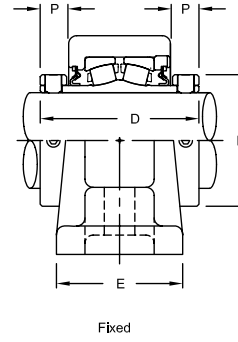
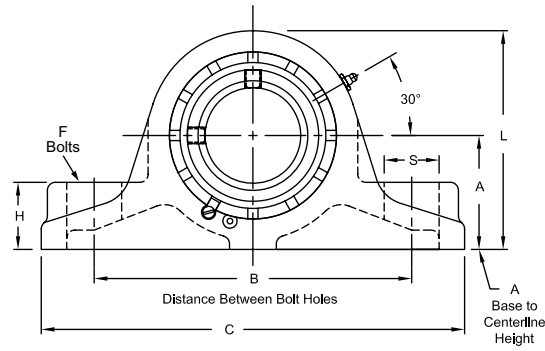
- Corrosion-resistant powder coating
- Cast iron housing
- Misalignment capabilities - total of 4°
- Broad range of sealing options
- Factory set clearance & lubrication
- Precision ground & superfinished raceways
- Two hardened spring locking collars
- Field interchangeable seals
- Fixed or Expansion - Up to 3/4" expansion
- See Features and Benefits for additional info on pages 10 - 13.



Bearing Dimensions

Size Code	Shaft Diameter	Expansion				Fixed				A Base to Centerline Height	B Distance Between Bolt Holes	G Bolt Hole Spacing (Width)	C	D	E	F Bolts	H	M	S	
		Part Number	L	P	Approx. Weight	Part Number	L	P	Approx. Weight											
Two-Bolt Pillow Block																				
4	1 7/16	ZPS5107	4 11/32	9/16	10.70	ZP5107	3 31/32	11/16	8.10	2 1/8	5 7/8	-	8 1/8	3 9/16	2 7/16	1/2	1 1/8	2 5/16	1 1/8	
		35.00	ZPS5035MM	110.31	14.29	4.90	ZP5035MM	100.79	17.46	3.70	59.98	149.23	-	206.38	90.49	61.91	13.00	28.58	58.74	28.58
5	1 1/2	ZPS5108	4 13/16	1/2	15.70	ZP5108	4 7/16	11/16	11.90	2 5/16	6 1/2	-	9	3 13/16	2 13/16	1/2	1 5/16	2 19/32	1 1/4	
		40.00			ZPS5040MM	7.10			ZP5040MM											5.40
		45.00	ZPS5045MM	122.24	12.70	6.80	ZP5045MM	112.71	17.46	5.20	58.74	165.10	-	228.60	96.84	71.44	13.00	33.34	65.88	31.75
		50.00	ZPS5115	4 15/16	9/16	16.10	ZP5115	4 3/4	11/16	13.40	2 1/2	7	-	9 3/4	3 13/16	2 7/8	5/8	1 7/16	2 7/8	1 1/4
6	2	ZPS5200	5 23/32	11/16	21.80	ZP5200	5 1/4	13/16	17.50	2 3/4	7 1/2	-	10 1/4	4 1/8	3 1/8	5/8	1 5/8	3 1/4	1 1/4	
		55.00			ZPS5055MM	145.24			17.46											9.80
		60.00	ZPS5207	6 3/16	3/4	25.90	ZP5207	5 3/4	7/8	21.20	3	8 1/4	-	11 1/4	4 3/8	3 3/8	3/4	1 3/4	3 9/16	1 3/8
		65.00	ZPS5065MM	157.16	19.05	11.20	ZP5065MM	146.05	22.23	9.00	76.20	209.55	-	285.75	111.13	85.73	19.00	44.45	90.50	34.93
9	2 1/2	ZPS5208	7 3/16	3/4	43.40	ZP5208	6 23/32	7/8	35.20	3 1/2	9 3/4	-	13	4 7/8	3 7/8	7/8	2 1/16	4 1/16	1 5/8	
		70.00			ZPS5211F	42.50			ZP5211F											33.90
		75.00			ZPS5215	40.40			ZP5215											32.60
		70.00	ZPS5070MM	182.56	19.05	19.20	ZP5070MM	170.64	22.23	15.40	88.90	247.65	-	330.20	123.83	98.43	22.00	52.39	103.20	41.28
		75.00	ZPS5075MM	18.70	ZP5075MM	15.00														
Four-Bolt Pillow Block																				
6	1 15/16	ZPS5115F	5 5/32	9/16	17.70	ZP5115F	5	11/16	15.80	2 1/2	7	2 1/4	9 3/4	3 13/16	4	5/8	1	2 7/8	1 1/4	
		50.00	ZPS5050MMF	130.96	14.29	8.00	ZP5050MMF	127.00	17.46	7.20	63.50	177.80	57.15	247.65	96.84	101.60	16.00	25.40	73.03	31.75
7	2	ZPS5200F	5 23/32	11/16	22.10	ZP5200F	5 1/2	13/16	19.60	2 3/4	7 1/2	2 1/4	10 1/4	4 1/8	4 1/8	5/8	1	3 1/4	1 1/4	
		21.70			ZP5203F	18.80														
		55.00	ZPS5055MMF	145.24	17.46	9.80	ZP5055MMF	39.70	20.64	8.50	69.85	190.50	57.15	260.35	104.78	104.78	16.00	25.40	82.60	31.75
8	2 7/16	ZPS5207F	6 7/32	3/4	27.40	ZP5207F	6	7/8	24.40	3	8 1/4	2 5/8	11 1/4	4 3/8	4 1/2	5/8	1 1/8	3 9/16	1 1/4	
		60.00	ZPS5060MMF	12.40	ZP5060MMF	11.00														
		65.00	ZPS5065MMF	157.94	19.05	12.00	ZP5065MMF	152.40	22.23	10.50	76.20	209.55	66.68	285.75	111.13	114.30	16.00	28.58	90.50	31.75
9	2 1/2	ZPS5208F	7 5/16	3/4	44.20	ZP5208F	7 1/16	7/8	38.20	3 1/2	9 3/4	2 3/4	13	4 7/8	5	3/4	1 3/8	4 1/16	1 1/2	
		70.00			ZPS5211F	43.40			ZP5211F											37.20
		75.00	ZPS5215F	41.80	ZP5215F	35.10														
		70.00	ZPS5070MMF	185.74	19.05	19.70	ZP5070MMF	170.39	22.23	16.90	88.90	247.65	69.85	330.20	123.83	127.00	19.00	34.93	103.20	38.10
	75.00	ZPS5075MMF	19.20	ZP5075MMF	16.50															
10	3 3/16	ZPS5303F	8 3/8	13/16	59.00	ZP5303F	8 1/8	15/16	52.00	4	11 1/2	3	15	5 5/16	5	3/4	1 1/2	4 29/32	1 1/2	
		37/16			ZPS5307F	57.00			ZP5307F											51.00

Continued...



Continued...

Bearing Dimensions

Size Code	Shaft Diameter	Expansion			Fixed			A Base to Centerline Height	B Distance Between Bolt Holes	G Bolt Hole Spacing (Width)	C	D	E	F Bolts	H	M	S		
		Part Number	L	P	Approx. Weight	Part Number	L											P	Approx. Weight
Four-Bolt Pillow Block (continued)																			
10	80.00	ZPS5080MMF			26.80	ZP5080MMF			23.50										
	85.00	ZPS5085MMF	212.73	20.64	26.30	ZP5085MMF	206.38	23.81	23.00	101.60	292.10	76.20	381.00	134.94	127.00	19.00	38.10	124.62	38.10
	90.00	ZPS5090MMF			25.80	ZP5090MMF			22.50										
11	3 11/16	ZPS5311F			98.00	ZP5311F			86.00										
	3 15/16	ZPS5315F	10 1/4	29/32	96.00	ZP5315F	9 7/8	1 1/32	84.00	5	13 1/4	3 1/2	16 3/4	6 1/8	6	7/8	1 1/2	5 5/8	1 1/2
	4	ZPS5400F			95.00	ZP5400F			83.00										
	100.00	ZPS5100MMF	260.35	23.01	43.50	ZP5100MMF	250.83	26.19	38.00	127.00	336.55	88.90	425.45	155.58	152.40	22.00	38.10	142.90	336.55
12	4 3/16	ZPS5403YF			122.00	ZP5403YF			110.00										
	4 7/16	ZPS5407YF	11 5/8	7/8	119.00	ZP5407YF	11 1/4	1 1/16	108.00	5 3/4	14 3/4	4	18 1/2	6 1/4	6 3/4	1	1 3/4	6 3/16	1 13/16
	4 1/2	ZPS5408YF			118.00	ZP5408YF			107.00										
	110.00	ZPS5110MMF	295.28	22.23	54.00	ZP5110MMF	285.75	26.99	49.00	146.05	374.65	101.60	469.90	158.75	171.45	25.00	44.45	157.16	46.04
13	5 15/16	ZPS5415F			206.00	ZP5415F			171.00										
	5	ZPS5500F	13 1/8	15/16	203.00	ZP5500F	12 1/2	1 5/32	168.00	6 1/8	16	4 1/4	20 1/4	7 7/8	7 1/2	1 1/8	1 7/8	7 1/16	2
	125.00	ZPS5125MMF	333.38	23.81	93.00	ZP5125MMF	317.50	29.37	78.00	155.58	406.40	107.95	514.35	200.03	190.50	28.00	47.63	179.39	50.80
	130.00	ZPS5130MMF			77.00	ZP5130MMF			92.00										
14	5 7/16	ZPS5507F	14 3/8	1 3/32	226.00	ZP5507F	14	1 7/32	211.00	6 11/16	18 5/16	3 11/16	22	8	6 1/4	1 1/8	2	8 3/16	2 1/16
	140.00	ZPS5140MMF	365.13	27.76	102.00	ZP5140MMF	355.60	30.96	96.00	169.86	465.14	93.66	558.80	203.20	158.75	28.00	50.80	207.96	52.39
	5 15/16	ZPS5515F			274.00	ZP5515F			255.00										
15	6	ZPS5600F	15 3/32	1 1/16	273.00	ZP5600F	14 3/4	1 5/32	254.00	7 1/16	20 1/2	4 3/16	24 3/4	8 1/8	6 3/4	1 1/8	2 1/8	8 5/8	2 1/4
	150.00	ZPS5150MMF	383.39	26.99	124.00	ZP5150MMF	374.65	29.37	115.00	179.39	520.70	106.36	628.65	206.38	171.45	28.00	53.98	219.08	57.15
	160.00	ZPS5160MMF			123.00	ZP5160MMF			114.00										
16	6 7/16	ZPS5607F			366.00	ZP5607F			339.00										
	6 15/16	ZPS5615F	16 3/4	1 3/16	352.00	ZP5615F	16 5/16	1 9/32	328.00	7 7/8	23	4 7/16	28	8 3/4	7 1/2	1 1/4	2 3/8	9 23/32	2 5/16
	7	ZPS5700F			348.00	ZP5700F			326.00										
	180.00	ZPS5180MMF	425.45	30.16	157.00	ZP5180MMF	414.34	32.54	148.00	200.03	584.20	112.71	711.20	222.25	190.50	32.00	60.33	246.86	58.74

Additional Notes

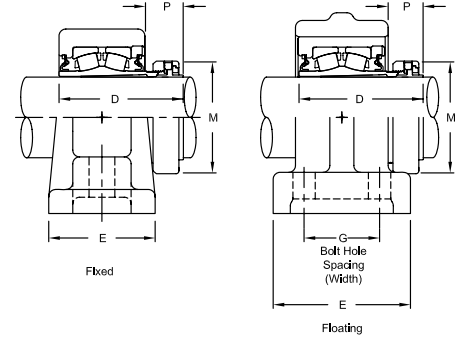
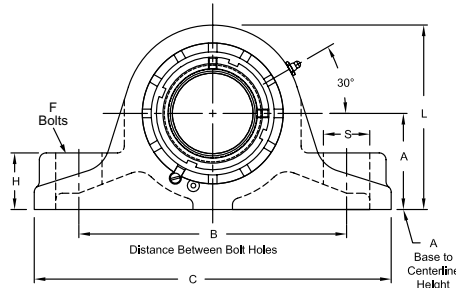
Please call 1-866-REXNORD for availability
 Metric bore sizes available, see the Rex Interchangeability guide
 Lubrication fitting tap size: for size code 4 thru 11, 1/8" PT; for all other size codes, 1/4" PT
 Base to centerline tolerance, +/- .005 in (+/- 0.13 mm)
 Bore size = nominal shaft size +.001 in/- .000 in (+0.03 mm/-0.00 mm)
 Expansion - size code 4 thru 8 is 3/8", size code 9 thru 11 is 1/2" & size code 12 thru 16 is 3/4"

Seals - To specify G, K or M seal, replace "Z" in part number with "G", "K" or "M"
 "K" seals only available in size codes 4 thru 11
 "G" seals available in size codes 3 thru 13
 Auxiliary end caps - available in all sizes
 For the Selection Guide, Load Ratings and Speed Limits, see the Spherical Roller Bearings Engineering section on pages 15 - 27.
 Note: Dimensions subject to change. Certified dimensions of ordered material furnished on request.

ZP6000, ZPS6000
Interchange: QVVPXT, QVVPX



Photo Shows a 2-Bolt Spherical Roller Bearing Pillow Block Unit



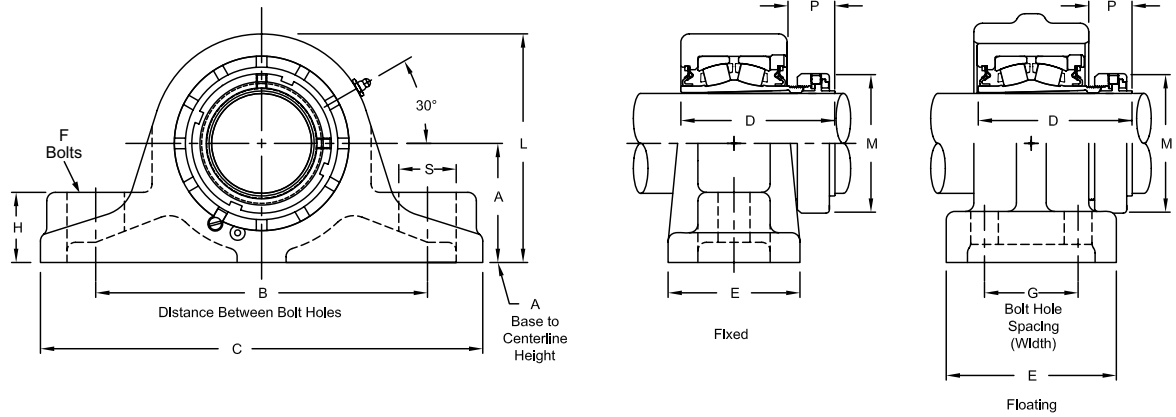
Product Features

- Spyglass Optical Strain Sensor (OSS) Technology
- Positive locking system
- Tapered adapter sleeve
- Corrosion-resistant powder coating
- Cast iron housing
- Misalignment capabilities - total of 4°
- Broad range of sealing options
- Factory set clearance & lubrication
- Precision ground & superfinished raceways
- See Features and Benefits for additional info on pages 10 - 13.

Bearing Dimensions

Size Code	Shaft Diameter	Expansion			Fixed			A Base to Centerline Height	B Distance Between Bolt Holes	G Bolt Hole Spacing (Width)	C	D	E	F Bolts	H	M	S		
		Part Number	L	P	Approx. Weight	Part Number	L											P	Approx. Weight
Two-Bolt Pillow Block																			
4	1 7/16	ZPS6107	4 11/32	1 9/64	10.20	ZP6107	3 11/16	1 9/64	7.60	2 1/8	5	-	8 1/8	3 21/64	2 7/16	1/2	1 1/8	2 25/64	1 1/8
5	1 11/16	ZPS6111	4 13/16	1 9/32	15.10	ZP6111	4 7/16	1 9/32	11.00	2 5/16	5 1/2	-	9	3 47/64	2 13/16	1/2	1 5/16	2 41/64	1 1/4
6	1 15/16	ZPS6115	4 15/16	1	16.10	ZP6115	4 3/4	1 1/8	13.40	2 1/2	7	-	9 3/4	3 41/64	2 7/8	5/8	1 7/16	2 55/64	1 1/4
	45.00	ZPS6045MM	125.41	25.40	16.10	ZP6045MM	120.65	28.58	13.40	63.50	177.80	-	247.65	92.47	73.02	16.00	36.51	72.63	31.75
7	2 3/16	ZPS6203	5 23/32	1 1/32	21.80	ZP6203	5 1/4	1 5/32	17.50	2 3/4	7 1/2	-	10 1/4	3 11/16	3 1/8	5/8	1 5/8	3 15/64	1 1/4
	55.00	ZPS6055MM	145.24	26.19	9.80	ZP6055MM	133.35	29.37	7.60	69.85	190.50	-	260.35	93.66	79.38	16.00	41.28	82.15	31.75
8	2 3/8	ZPS6206	6 3/16	1 19/64	25.90	ZP6206	5 3/4	1 27/64	22.20	3	8 1/4	-	11 1/4	4 1/16	3 3/8	3/4	1 3/4	3 19/32	1 3/8
	2 7/16	ZPS6207		24.90	ZP6207	21.20		21.20											
	60.00	ZPS6060MM	157.16	32.94	11.70	ZP6060MM	146.05	36.12	9.60	76.20	209.55	-	285.75	103.19	85.73	19.00	44.45	91.28	34.93
9	2 11/16	ZPS6211	7 3/16	1 17/64	43.40	ZP6211	6 23/32	1 25/64	35.20	3 1/2	9 3/4	-	13	4 17/32	3 7/8	7/8	2 1/16	4 3/32	1 5/8
	2 3/4	ZPS6212			42.40	ZP6212			34.20										
	2 15/16	ZPS6215			42.50	ZP6215			33.90										
	70.00	ZPS6070MM			182.56	32.16			19.20										
	75.00	ZPS6075MM	182.56	32.16	18.70	ZP6075MM	170.64	35.32	15.00	88.90	247.65	-	330.20	115.09	98.43	22.00	52.39	103.98	41.28
Four-Bolt Pillow Block																			
6	1 15/16	ZPS6115F	5 5/32	1	17.70	ZP6115F	5	1 1/8	15.80	2 1/2	7	2 1/4	9 3/4	3 41/64	4	5/8	1	2 55/64	1 1/4
	45.00	ZPS6045MMF	130.96	25.40	17.70	ZP6045MMF	127.00	28.58	15.80	63.50	177.80	57.15	247.65	92.47	101.60	16.00	25.40	72.63	31.75
7	2 3/16	ZPS6203F	5 23/32	1 1/32	22.10	ZP6203F	5 1/2	1 5/32	19.60	2 3/4	7 1/2	2 1/4	10 1/4	3 11/16	4 1/8	5/8	1	3 15/64	1 1/4
	55.00	ZPS6055MMF	145.24	26.19	9.80	ZP6055MMF	39.70	29.37	8.50	69.85	190.50	57.15	260.35	93.66	104.78	16.00	25.40	82.15	31.75
8	2 3/8	ZPS6206F	6 7/32	1 19/64	28.40	ZP6206F	6	1 27/64	25.40	3	8 1/4	2 5/8	11 1/4	4 1/16	4 1/2	5/8	1 1/8	3 19/32	1 1/4
	2 7/16	ZPS6207F			27.40	ZP6207F			24.40										
	60.00	ZPS6060MMF	157.94	32.94	12.40	ZP6060MMF	152.40	36.12	11.00	76.20	209.55	66.68	285.75	103.19	114.30	16.00	28.58	91.28	31.75
9	2 11/16	ZPS6211F	7 5/16	1 17/64	44.20	ZP6211F	7 1/16	1 25/64	38.20	3 1/2	9 3/4	2 3/4	13	4 17/32	5	3/4	1 3/8	4 3/32	1 1/2
	2 3/4	ZPS6212F			42.50	ZP6212F			36.50										
	2 15/16	ZPS6215F			43.40	ZP6215F			37.20										
	70.00	ZPS6070MMF			185.74	32.16			19.70										
	75.00	ZPS6075MMF	185.74	32.16	19.20	ZP6075MMF	170.39	35.32	16.50	88.90	247.65	69.85	330.20	115.09	127.00	19.00	34.93	103.98	38.10
10	3 3/16	ZPS6303F	8 3/8	1 15/32	59.00	ZP6303F	8 1/8	1 19/32	52.00	4	11 1/2	3	15	5 1/32	5	3/4	1 1/2	4 61/64	1 1/2
	3 7/16	ZPS6307F			57.00	ZP6307F			51.00										
	80.00	ZPS6080MMF			212.73	37.29			26.80										
	85.00	ZPS6085MMF	212.73	37.29	26.30	ZP6085MMF	206.38	40.48	23.00	101.60	292.10	76.20	381.00	127.79	127.00	19.00	38.10	125.81	38.10
11	3 11/16	ZPS6311F	10 1/4	1 39/64	98.00	ZP6311F	9 7/8	1 47/64	86.00	5	13 1/4	3 1/2	16 3/4	5 25/32	6	7/8	1 1/2	5 43/64	1 1/2
	3 15/16	ZPS6315F			96.00	ZP6315F			84.00										
	90.00	ZPS6090MMF			260.35	40.87			43.50										
	100.00	ZPS6100MMF	260.35	40.87	43.50	ZP6100MMF	250.83	44.05	38.00	127.00	336.55	88.90	425.45	146.84	152.40	22.00	38.10	144.07	336.55

Continued...



Continued...

Bearing Dimensions

Size Code	Shaft Diameter	Expansion				Fixed				A Base to Centerline Height	B Distance Between Bolt Holes	G Bolt Hole Spacing (Width)	C	D	E	F Bolts	H	M	S
		Part Number	L	P	Approx. Weight	Part Number	L	P	Approx. Weight										
Four-Bolt Pillow Block (continued)																			
12	4 3/16	ZPS6403YF	11 5/8	1 3/4	122.00	ZP6403YF	11 1/4	1 7/8	110.00	5 3/4	14 3/4	4	18 1/2	6 1/4	6 3/4	1	1 3/4	6 1/16	1 13/16
	4 7/16	ZPS6407YF			119.00	ZP6407YF			118.00										
	110.00	ZPS6110MMF	295.28	44.45	54.00	ZP6110MMF	285.75	47.63	49.00	146.05	374.65	101.60	469.90	158.75	171.45	25.00	44.45	153.99	46.04
13	4 15/16	ZPS6415F	13 1/8	2 1/64	206.00	ZP6415F	12 1/2	2 1/4	171.00	6 1/8	16	4 1/4	20 1/4	7 15/16	7 1/2	1 1/8	1 7/8	6 61/64	2
	125.00	ZPS6125MMF	333.38	51.20	93.00	ZP6125MMF	317.50	57.15	78.00										
14	5 7/16	ZPS6507F	14 3/8	2 15/16	226.00	ZP6507F	14	3 3/64	211.00	6 11/16	18 5/16	3 11/16	-	8 49/64	6 1/4	1 1/8	2	8 1/64	2 1/16
15	5 15/16	ZPS6515F	15 5/32	3 23/64	274.00	ZP6515F	14 3/4	3 7/16	255.00	7 1/16	20 1/2	4 3/16	-	9 19/64	6 3/4	1 1/8	2 1/8	8 21/32	2 1/4
16	6 7/16	ZPS6607F	16 3/4	3 37/64	366.00	ZP6607F	16 5/16	3 43/64	339.00	7 7/8	23	4 7/16	-	10	7 1/2	1 1/4	2 3/8	9 3/4	2 5/16
	6 15/16	ZPS6615F			352.00	ZP6615F			328.00										

Additional Notes

- Please call 1-866-REXNORD for availability
- Metric bore sizes available, see the Rex Interchangeability guide
- Lubrication fitting tap size: for size code 6 thru 11, 1/8" PT; for all other size codes, 1/4" PT
- Base to centerline tolerance, +/- .005 in (+/- 0.13 mm)
- Expansion - size code 6 thru 8 is 3/8", size code 9 thru 11 is 1/2" & size code 12 thru 13 is 3/4"
- Seals - To specify G, K or M seal, replace "Z" in part number with "G", "K" or "M"

- "K" seals only available in size codes 3 thru 11
- "G" seals available in size codes 3 thru 13
- Auxiliary end caps - available in all sizes
- For the Selection Guide, Load Ratings and Speed Limits, see the Spherical Roller Bearings Engineering section on pages 15 - 27.
- Note: Dimensions subject to change. Certified dimensions of ordered material furnished on request.

ZP9000, ZPS9000

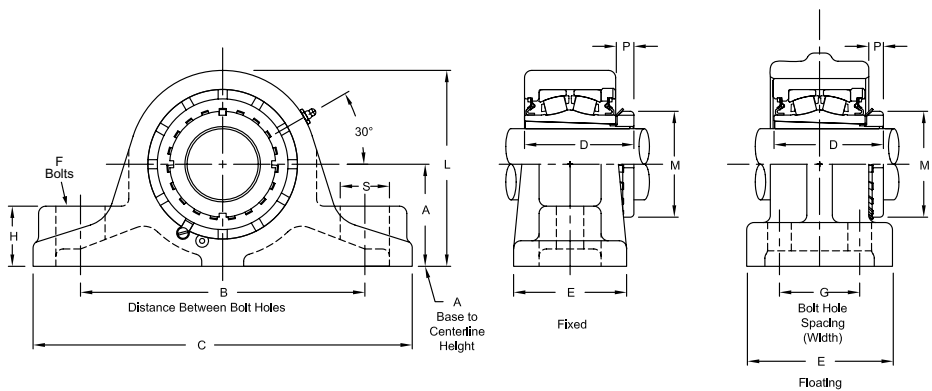
Interchange: QVVPKT, QVVPK, TAPKT, TAPK



Photo Shows a 2-Bolt Spherical Roller Bearing Pillow Block Unit

Product Features

- Corrosion-resistant powder coating
- Cast iron housing
- Misalignment capabilities - total of 4°
- Broad range of sealing options
- Factory set clearance & lubrication
- Precision ground & superfinished raceways
- Enhanced life mounting style
- Field interchangeable seals
- Fixed or Expansion - Up to 3/4" expansion
- See Features and Benefits for additional info on pages 10 - 13.



Bearing Dimensions

Size Code	Shaft Diameter	Expansion			Fixed			A Base to Centerline Height	B Distance Between Bolt Holes	G Bolt Hole Spacing (Width)	C	D	E	F Bolts	H	M	S												
		Part Number	L	P	Approx. Weight	Part Number	L											P	Approx. Weight										
Two-Bolt Pillow Block																													
7	1 15/16	ZPS9115	5 23/32	1/2	20.50	ZP9115	5 1/4	19/32	16.00	2 3/4	7 1/2	-	10 1/4	3 5/32	3 1/8	5/8	1 5/8	2 31/32	1 1/4										
	2	ZPS9200			20.30	ZP9200			15.90																				
	45.00	ZPS9045MMF	145.24	12.70	9.30	ZP9045MMF	133.35	15.08	7.00											69.85	190.50	-	260.35	80.17	79.38	16.00	41.28	75.40	31.75
	50.00	ZPS9050MMF			9.10	ZP9050MMF			6.80																				
8	2 3/16	ZPS9203	6 3/16	19/32	24.80	ZP9203	5 3/4	23/32	20.10	3	8 1/4	-	11 1/4	3 11/32	3 3/8	3/4	1 3/4	3 3/8	1 3/8										
	55.00	ZPS9055MMF	157.16	15.09	11.20	ZP9055MMF	146.05	18.26	9.10	76.20	209.55	-	285.75	84.93	85.73	19.00	44.45	85.73	34.93										
9	2 7/16	ZPS9207	7 3/16	19/32	40.60	ZP9207	6 23/32	5/8	32.20	3 1/2	9 3/4	-	13	3 3/4	3 7/8	7/8	2 1/16	3 5/8	1 5/8										
	2 1/2	ZPS9208			40.50	ZP9208			31.90																				
Four-Bolt Pillow Block																													
7	1 15/16	ZPS9115F	5 23/32	1/2	20.50	ZP9115F	5 1/2	19/32	18.10											2 3/4	7 1/2	2 1/4	10 1/4	3 5/32	4 1/8	5/8	1	2 31/32	1 1/4
	2	ZPS9200F			20.30	ZP9200F			17.90																				
	45.00	ZPS9045MMFF	145.24	12.70	9.30	ZP9045MMFF	39.70	15.08	8.20	69.85	190.50	57.15	260.35	80.17	104.78	16.00	25.40	75.40	31.75										
	50.00	ZPS9050MMFF			9.10	ZP9050MMFF			8.00																				
8	2 3/16	ZPS9203F	6 7/32	19/32	26.70	ZP9203F	6	23/32	22.80	3	8 1/4	2 5/8	11 1/4	3 11/32	4 1/2	5/8	1 1/8	3 3/8	1 1/4										
	55.00	ZPS9055MMFF	157.94	15.09	12.10	ZP9055MMFF	152.40	18.26	10.30	76.20	209.55	66.68	285.75	84.93	114.30	16.00	28.58	85.73	31.75										
9	2 7/16	ZPS9207F	7 5/16	19/32	41.80	ZP9207F	7 1/16	5/8	35.40	3 1/2	9 3/4	2 3/4	13	3 3/4	5	3/4	1 3/8	3 5/8	1 1/2										
	2 1/2	ZPS9208F			41.70	ZP9208F			34.60																				
10	2 11/16	ZPS9211F	8 3/8	11/16	56.00	ZP9211F	8 1/8	13/16	51.20											4	11 1/2	3	15	4 1/4	5	3/4	1 1/2	4 13/32	1 1/2
	2 15/16	ZPS9215F			55.00	ZP9215F			50.00																				
	75.00	ZPS9075MMFF	212.73	17.47	25.00	ZP9075MMFF	206.38	20.64	23.00	101.60	292.10	76.20	381.00	107.95	127.00	19.00	38.10	111.92	38.10										
	3 3/16	ZPS9303F	10 1/4	13/16	95.00	ZP9303F	9 7/8	15/16	83.00	5	13 1/4	3 1/2	16 3/4	5	6	7/8	1 1/2	5 3/16	1 1/2										
3 7/16	ZPS9307F	93.00			ZP9307F	81.00																							
80.00	ZPS9080MMFF	260.35	20.64	42.00	ZP9080MMFF	250.83	23.81	36.70	127.00											336.55	88.90	425.45	127.00	152.40	22.00	38.10	131.76	336.55	
12	3 11/16	ZPS9311YF	11 5/8	29/32	121.00	ZP9311YF	11 1/4	1 1/32	110.00											5 3/4	14 3/4	4	18 1/2	5 17/32	6 3/4	1	1 3/4	5 23/32	1 13/16
	3 15/16	ZPS9315YF			119.00	ZP9315YF			108.00																				
	4	ZPS9400YF	118.00	ZP9400YF	107.00																								
	100.00	ZPS9100MMFF	295.28	23.01	53.00	ZP9100MMFF	285.75	23.01	49.00	146.05	374.65	101.60	469.90	140.49	171.45	25.00	44.45	145.26	46.04										
13	4 3/16	ZPS9403F	13 1/8	29/32	204.00	ZP9403F	12 1/2	1 1/8	174.00	6 1/8	16	4 1/4	20 1/4	6 3/4	7 1/2	1 1/8	1 7/8	6 1/8	2										
	4 7/16	ZPS9407F			202.00	ZP9407F			168.00																				
14	4 15/16	ZPS9415F	14 3/8	1 5/32	222.00	ZP9415F	14	1 1/8	202.00											6 11/16	18 5/16	3 11/16	22	7 1/16	6 1/4	1 1/8	2	7 3/32	2 1/16
	5	ZPS9500F			220.00	ZP9500F			201.00																				
15	5 3/16	ZPS9503F	15 3/32	1 3/8	273.00	ZP9503F	14 3/4	1 5/16	254.00	7 1/16	20 1/2	4 3/16	24 3/4	7 5/16	6 3/4	1 1/8	2 1/8	8 1/16	2 1/16										
	5 7/16	ZPS9507F			269.00	ZP9507F			250.00																				
16	5 15/16	ZPS9515F	16 3/4	1 3/4	350.00	ZP9515F	16 5/16	1 11/16	328.00											7 7/8	23	4 7/16	28	7 3/4	7 1/2	1 1/4	2 3/8	9 1/16	2 5/16
	6	ZPS9600F			349.00	ZP9600F			327.00																				
	6 7/16	ZPS9607F			342.00	ZP9607F			320.00																				

Additional Notes

- Please call 1-866-REXNORD for availability
- Lubrication fitting tap size: for size code 7 thru 11, 1/8" PT; for all other size codes, 1/4" PT
- Base to centerline tolerance, +/- .005 in (+/- 0.13 mm)
- Expansion - size code 7 thru 8 is 3/8", size code 9 thru 11 is 1/2" & size code 12 thru 16 is 3/4"
- Seals - To specify G, K or M seal, replace "Z" in part number with "G", "K" or "M"

"K" seals only available in size codes 7 thru 11

"G" seals available in size codes 3 thru 13

Auxiliary end caps - available in all sizes

For the Selection Guide, Load Ratings and Speed Limits, see the Spherical Roller Bearings Engineering section on pages 15 - 27.

Note: Dimensions subject to change. Certified dimensions of ordered material furnished on request.

ZEP2000, ZEPS2000

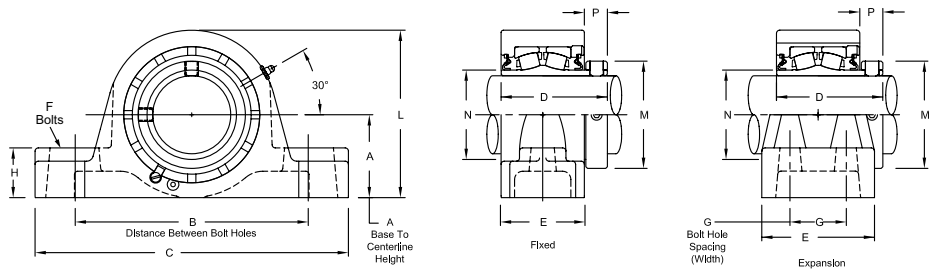
Interchange: EP2BS2, P2BE, EP4BS2, P4BE, (F)SYE, USRBE5000, (E)RPBA, QAP, QAPR, EP2BTRB, EP4BTRB



Photo Shows a 2-Bolt Spherical Roller Bearing Pillow Block Unit

Product Features

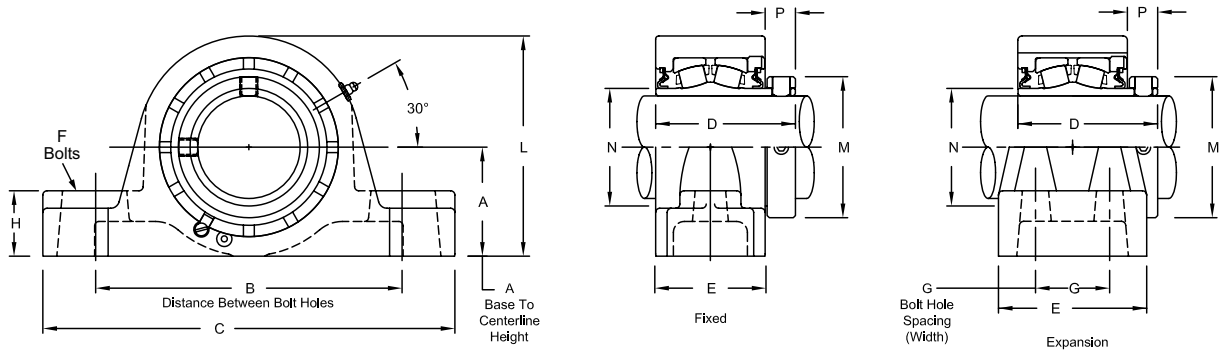
- Corrosion-resistant powder coating
 - Cast iron housing
 - Misalignment capabilities - total of 4°
 - Broad range of sealing options
 - Factory set clearance & lubrication
 - Precision ground & superfinished raceways
 - Hardened spring locking collar
 - Field interchangeable seals
- See Features and Benefits for additional info on pages 10 - 13.



Bearing Dimensions

Size Code	Shaft Diameter	Expansion		A Base to Centerline Height	B Distance Between Bolt Holes		G Bolt Hole Spacing (Width)	C	D	E	F Bolts	H	L	M	N	P	Approx. Weight
		Part Number	Part Number		Min.	Max.											
Two-Bolt Pillow Block																	
3	1 1/8	-	ZEP2102	1 1/2	4 7/16	5	-	6 3/8	2 11/16	2 1/8	1/2	7/8	3 1/4	1 31/32	1 17/32	9/16	5.80
	1 3/16	-	ZEP2103														5.70
	1 1/4	-	ZEP2104														5.70
	30.00	-	ZEP2030MM	38.10	112.71	127.00	-	161.93	68.26	53.98	13.00	22.23	82.55	50.00	38.890	14.29	2.60
4	1 7/16	ZEPS2107	ZEP2107	1 7/8	4 3/4	6	-	7 3/8	2 7/8	2 1/4	1/2	1 1/8	3 7/8	2 5/16	1 3/4	1 1/16	6.90
	1 1/2	-	ZEP2108	2 1/8	5 1/4	6 1/2	-	7 7/8	2 7/8	2 1/4	1/2	1 1/4	4 3/8	2 5/16	1 3/4	1 1/16	9.50
	35.00	ZEPS2035MM	ZEP2035MM	47.63	120.65	152.40	-	187.33	73.02	57.15	13.00	28.58	98.43	58.74	44.450	17.46	3.10
5	1 11/16	ZEPS2111	ZEP2111	2 1/8	5 1/4	6 1/2	-	7 7/8	3 1/8	2 1/2	1/2	1 1/4	4 3/8	2 19/32	2 1/32	1 1/16	9.90
	1 3/4	-	ZEP2112	2 1/4	6 1/16	7 1/4	-	8 7/8	3 1/8	2 1/2	5/8	1 5/16	4 9/16	2 19/32	2 1/32	1 1/16	11.80
	40.00	ZEPS2040MM	ZEP2040MM	53.98	133.35	165.10	-	200.03	79.38	63.50	13.00	31.75	111.13	65.88	51.590	17.46	4.50
	45.00	ZEPS2045MM	ZEP2045MM	57.15	153.99	184.15	-	225.43	79.38	63.50	16.00	33.34	115.89	65.88	51.590	17.46	5.40
6	1 15/16	ZEPS2115	ZEP2115	2 1/4	6 1/16	7 1/4	-	8 7/8	3 1/8	2 1/2	5/8	1 5/16	4 9/16	2 7/8	2 5/16	1 1/16	11.50
	2	ZEPS2200	ZEP2200														11.40
	50.00	ZEPS2050MM	ZEP2050MM														57.15
7	2 3/16	ZEPS2203	ZEP2203	2 1/2	6 9/16	8	-	9 9/8	3 5/16	2 9/16	5/8	1 1/2	5	3 1/4	2 5/8	1 13/16	14.80
	2 1/4	-	ZEP2204	2 3/4	6 15/16	8 3/4	-	10 1/2	3 5/16	2 9/16	5/8	1 5/8	5 7/16	3 1/4	2 5/8	7/8	18.60
	55.00	ZEPS2055MM	ZEP2055MM	63.50	166.69	203.20	-	244.48	84.14	65.09	16.00	38.10	127.00	82.60	66.680	20.64	6.70
8	2 3/8	ZEPS2206	ZEP2206	2 3/4	6 15/16	8 3/4	-	10 1/2	3 1/2	2 11/16	5/8	1 5/8	5 1/2	3 9/16	2 29/32	7/8	18.30
	2 7/16	ZEPS2207	ZEP2207														18.20
	2 1/2	ZEPS2208	ZEP2208														17.90
	60.00	ZEPS2060MM	ZEP2060MM	69.85	176.21	222.25	-	266.70	88.90	68.26	16.00	41.28	139.70	90.50	73.820	22.23	8.30
	65.00	ZEPS2065MM	ZEP2065MM	69.85	176.21	222.25	-	266.70	88.90	68.26	16.00	41.28	139.70	90.50	73.820	22.23	8.10
9	2 11/16	ZEPS2211	ZEP2211	3 1/8	7 13/16	9 3/4	-	11 13/16	4	3 3/16	3/4	1 7/8	6 5/16	4 1/16	3 3/8	7/8	29.30
	2 3/4	ZEPS2212	ZEP2212														28.80
	2 15/16	ZEPS2215	ZEP2215														27.70
	3	ZEPS2300	ZEP2300	27.50													
	70.00	ZEPS2070MM	ZEP2070MM	79.38	198.44	247.65	-	300.04	101.60	80.96	19.00	47.63	160.34	103.20	85.730	22.23	13.00
	75.00	ZEPS2075MM	ZEP2075MM	79.38	198.44	247.65	-	300.04	101.60	80.96	19.00	47.63	160.34	103.20	85.730	22.23	12.60
10	3 3/16	ZEPS2303	ZEP2303	3 3/4	9 5/16	11 5/16	-	13 13/16	4 3/8	3 1/2	7/8	2 1/4	7 1/2	4 29/32	3 31/32	15/16	44.50
	3 7/16	ZEPS2307	ZEP2307														42.50
	3 1/2	ZEPS2308	ZEP2308														42.00
	80.00	ZEPS2080MM	ZEP2080MM	95.25	236.54	287.34	-	350.84	111.13	88.90	22.00	57.15	190.50	124.62	100.790	23.81	20.40
	85.00	ZEPS2085MM	ZEP2085MM	95.25	236.54	287.34	-	350.84	111.13	88.90	22.00	57.15	190.50	124.62	100.790	23.81	19.40
	90.00	ZEPS2090MM	ZEP2090MM	95.25	236.54	287.34	-	350.84	111.13	88.90	22.00	57.15	190.50	124.62	100.790	23.81	18.90

Continued...



Continued...

Bearing Dimensions

Size Code	Shaft Diameter	Expansion		Fixed		A Base to Centerline Height	B Distance Between Bolt Holes		G Bolt Hole Spacing (Width)	C	D	E	F Bolts	H	L	M	N	P	Approx. Weight
		Part Number	Part Number	Min.	Max.														
Four-Bolt Pillow Block																			
8	2 3/8	ZEPS2206F	ZEP2206F																18.40
	2 7/16	ZEPS2207F	ZEP2207F	2 3/4	6 15/16	8 3/4	1 7/8	10 1/2	3 1/2	3 5/8	5/8	1 5/8	5 1/2	3 9/16	2 29/32	7/8		18.30	
	2 1/2	ZEPS2208F	ZEP2208F																18.00
	60.00	ZEPS2060MMF	ZEP2060MMF	69.85	176.21	222.25	47.63	266.70	88.90	92.08	16.00	41.28	139.70	90.50	73.820	22.23		8.40	
	65.00	ZEPS2065MMF	ZEP2065MMF																8.20
9	2 11/16	ZEPS2211F	ZEP2211F																28.50
	2 3/4	ZEPS2212F	ZEP2212F	3 1/8	7 13/16	9 7/8	2 1/8	11 13/16	4	4 1/4	5/8	1 7/8	6 5/16	4 1/16	3 3/8	7/8		28.30	
	2 15/16	ZEPS2215F	ZEP2215F																27.30
	3	ZEPS2300F	ZEP2300F																27.00
	70.00	ZEPS2070MMF	ZEP2070MMF	79.38	198.44	250.83	53.98	300.04	101.60	107.95	16.00	47.63	160.34	103.20	85.730	22.23		12.90	
75.00	ZEPS2075MMF	ZEP2075MMF																12.50	
10	3 3/16	ZEPS2303F	ZEP2303F																45.00
	3 7/16	ZEPS2307F	ZEP2307F	3 3/4	9 5/16	11 5/16	2 3/8	13 13/16	4 3/8	4 3/4	3/4	2 1/4	7 1/2	4 29/32	3 31/32	15/16		43.00	
	3 1/2	ZEPS2308F	ZEP2308F																42.50
	80.00	ZEPS2080MMF	ZEP2080MMF	95.25	236.54	287.34	60.33	350.84	111.13	120.65	19.00	57.15	190.50	124.62	100.790	23.81		20.30	
	85.00	ZEPS2085MMF	ZEP2085MMF																19.50
90.00	ZEPS2090MMF	ZEP2090MMF																19.00	
11	3 11/16	ZEPS2311F	ZEP2311F																63.00
	3 15/16	ZEPS2315F	ZEP2315F	4 1/4	12	13	2 1/4	15 1/4	5 1/16	4 1/2	3/4	2 5/8	8 5/8	5 5/8	4 9/16	1 1/32		61.00	
	4	ZEPS2400F	ZEP2400F																60.00
	100.00	ZEPS2100MMF	ZEP2100MMF	107.95	304.80	330.20	57.15	387.35	128.59	114.30	19.00	66.68	219.08	142.90	115.890	26.19		27.70	

Additional Notes

- Please call 1-866-REXNORD for availability
- Metric bore sizes available, see the Rex Interchangeability guide
- Lubrication fitting tap size, 1/8" PT
- Base to centerline tolerance, +/- .005 in (+/- 0.13 mm)
- Bore size = nominal shaft size +.001 in/-.000 in (+0.03 mm/-0.00 mm)
- Seals - To specify G, K or M seal, replace "Z" in part number with "G", "K" or "M"
- Auxiliary end caps - available in all size codes except for size code 3 and all expansion units

For the Selection Guide, Load Ratings and Speed Limits, see the Spherical Roller Bearings Engineering section on pages 15 - 27.

Note: Dimensions subject to change. Certified dimensions of ordered material furnished on request.

ZEP3000, ZEPS3000

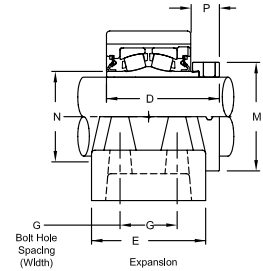
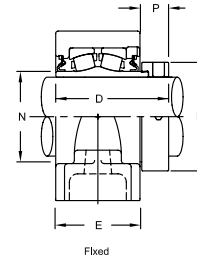
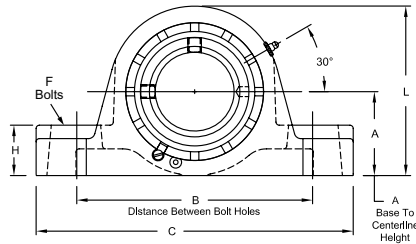
Interchange: QMP, QMPR



Photo Shows a 2-Bolt Spherical Roller Bearing Pillow Block Unit

Product Features

- Corrosion-resistant powder coating
 - Cast iron housing
 - Misalignment capabilities - total of 4°
 - Broad range of sealing options
 - Factory set clearance & lubrication
 - Precision ground & superfinished raceways
 - Eccentric locking collar
 - Field interchangeable seals
- See Features and Benefits for additional info on pages 10 - 13.



Bearing Dimensions

Size Code	Shaft Diameter	Expansion		A Base to Centerline Height	B Min. Distance Between Bolt Holes	B Max. Distance Between Bolt Holes	G Bolt Hole Spacing (Width)	C	D	E	F Bolts	H	L	M	N	P	Approx. Weight
		Part Number	Part Number														
Two-Bolt Pillow Block																	
4	1 ⁷ / ₁₆	ZEPS3107	ZEP3107	1 ⁷ / ₈	4 ³ / ₄	6	-	7 ³ / ₈	2 ⁵⁹ / ₆₄	2 ¹ / ₄	1/2	1 ¹ / ₈	3 ⁷ / ₈	2 ⁵ / ₁₆	1 ³ / ₄	2 ⁵ / ₃₂	7.10
5	1 ¹¹ / ₁₆	ZEPS3111	ZEP3111	2 ¹ / ₈	5 ¹ / ₄	6 ¹ / ₂	-	7 ⁷ / ₈	3 ³ / ₁₆	2 ¹ / ₂	1/2	1 ¹ / ₄	4 ³ / ₈	2 ⁵ / ₈	2 ¹ / ₃₂	3/4	10.10
6	1 ¹⁵ / ₁₆	ZEPS3115	ZEP3115	2 ¹ / ₄	6 ¹ / ₁₆	7 ¹ / ₄	-	8 ⁷ / ₈	3 ⁹ / ₃₂	2 ¹ / ₂	5/8	1 ⁵ / ₁₆	4 ⁹ / ₁₆	2 ³ / ₄	2 ⁵ / ₁₆	2 ⁷ / ₃₂	11.70
7	2 ³ / ₁₆	ZEPS3203	ZEP3203	2 ¹ / ₂	6 ⁹ / ₁₆	8	-	9 ⁵ / ₈	3 ¹ / ₂	2 ⁹ / ₁₆	5/8	1 ¹ / ₂	5	3 ¹ / ₄	2 ⁵ / ₈	3 ¹ / ₃₂	15.10
8	2 ⁷ / ₁₆	ZEPS3207	ZEP3207	2 ³ / ₄	6 ¹⁵ / ₁₆	8 ³ / ₄	-	10 ¹ / ₂	3 ²¹ / ₃₂	2 ¹¹ / ₁₆	5/8	1 ⁵ / ₈	5 ¹ / ₂	3 ⁹ / ₁₆	2 ²⁹ / ₃₂	1 ¹ / ₆₄	18.40
	2 ¹ / ₂	ZEPS3208	ZEP3208														18.10
9	2 ¹¹ / ₁₆	ZEPS3211	ZEP3211	3 ¹ / ₈	7 ¹³ / ₁₆	9 ³ / ₄	-	11 ¹³ / ₁₆	4 ¹³ / ₆₄	3 ³ / ₁₆	3/4	1 ⁷ / ₈	6 ⁵ / ₁₆	4 ¹ / ₁₆	3 ³ / ₈	1 ¹ / ₆₄	29.50
	2 ¹⁵ / ₁₆	ZEPS3215	ZEP3215														28.10
10	3 ⁷ / ₁₆	ZEPS3307	ZEP3307	3 ³ / ₄	9 ⁵ / ₁₆	11 ⁵ / ₁₆	-	13 ¹³ / ₁₆	4 ³⁷ / ₆₄	3 ¹ / ₂	7/8	2 ¹ / ₄	7 ¹ / ₂	4 ¹⁵ / ₁₆	3 ³¹ / ₃₂	1 ⁹ / ₆₄	43.10
	3 ¹ / ₂	ZEPS3308	ZEP3308														42.20
Four-Bolt Pillow Block																	
8	2 ⁷ / ₁₆	ZEPS3207F	ZEP3207F	2 ³ / ₄	6 ¹⁵ / ₁₆	8 ³ / ₄	1 ⁷ / ₈	10 ¹ / ₂	3 ²¹ / ₃₂	3 ⁵ / ₈	5/8	1 ⁵ / ₈	5 ¹ / ₂	3 ⁹ / ₁₆	2 ²⁹ / ₃₂	1 ¹ / ₆₄	18.50
	2 ¹ / ₂	ZEPS3208F	ZEP3208F														18.20
9	2 ¹¹ / ₁₆	ZEPS3211F	ZEP3211F	3 ¹ / ₈	7 ¹³ / ₁₆	9 ⁷ / ₈	2 ¹ / ₈	11 ¹³ / ₁₆	4 ¹³ / ₆₄	4 ¹ / ₄	5/8	1 ⁷ / ₈	6 ⁵ / ₁₆	4 ¹ / ₁₆	3 ³ / ₈	1 ¹ / ₆₄	28.70
	2 ¹⁵ / ₁₆	ZEPS3215F	ZEP3215F														27.70
10	3 ⁷ / ₁₆	ZEPS3307F	ZEP3307F	3 ³ / ₄	9 ⁵ / ₁₆	11 ⁵ / ₁₆	2 ³ / ₈	13 ¹³ / ₁₆	4 ³⁷ / ₆₄	4 ³ / ₄	3/4	2 ¹ / ₄	7 ¹ / ₂	4 ¹⁵ / ₁₆	3 ³¹ / ₃₂	1 ⁹ / ₆₄	43.60
	3 ¹ / ₂	ZEPS3308F	ZEP3308F														42.70
11	3 ¹⁵ / ₁₆	ZEPS3315F	ZEP3315F	4 ¹ / ₄	12	13	2 ¹ / ₄	15 ¹ / ₄	5 ³ / ₁₆	4 ¹ / ₂	3/4	2 ⁵ / ₈	8 ⁵ / ₈	5 ⁵ / ₈	4 ⁹ / ₁₆	1 ¹ / ₁₆	61.00

Additional Notes

- Please call 1-866-REXNORD for availability
 - Lubrication fitting tap size, 1/8" PT
 - Base to centerline tolerance, +/- .005 in (+/- 0.13 mm)
 - Bore size = nominal shaft size +.001 in/- .000 in (+0.03 mm/-0.00 mm)
 - Seals - To specify G, K or M seal, replace "Z" in part number with "G", "K" or "M"
 - Auxiliary end caps - available in all size codes, except expansion units
- For the Selection Guide, Load Ratings and Speed Limits, see the Spherical Roller Bearings Engineering section on pages 15 - 27.

Note: Dimensions subject to change. Certified dimensions of ordered material furnished on request.

ZEP5000, ZEPS5000

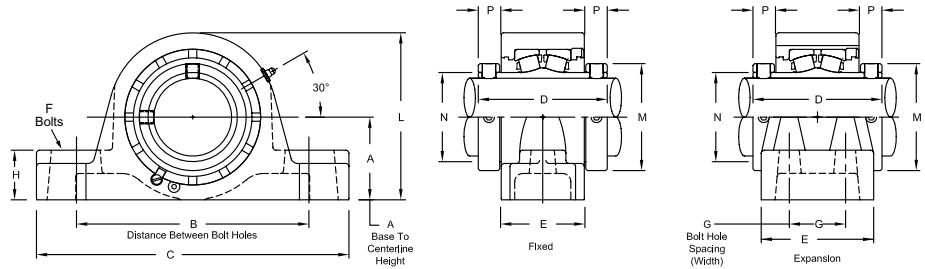
Interchange: (E)RPB, QAAP(F), QAAPR



Photo Shows a 2-Bolt Spherical Roller Bearing Pillow Block Unit

Product Features

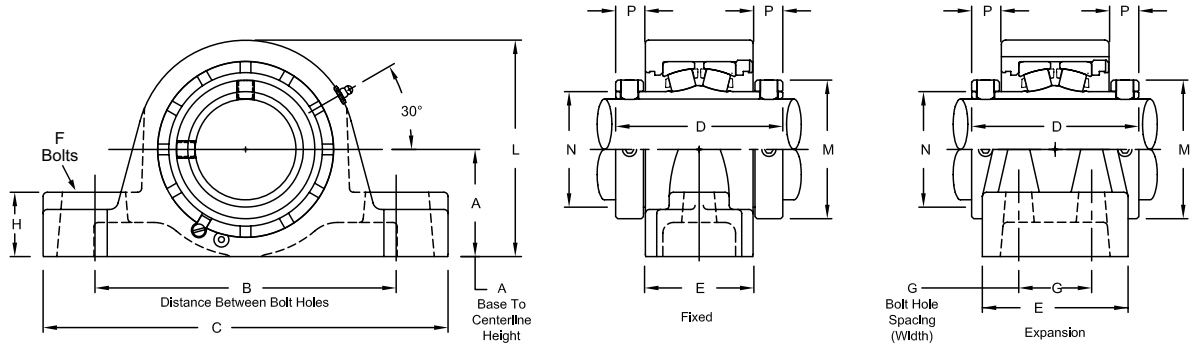
- Corrosion-resistant powder coating
- Cast iron housing
- Misalignment capabilities - total of 4°
- Broad range of sealing options
- Factory set clearance & lubrication
- Precision ground & superfinished raceways
- Two hardened spring locking collars
- Field interchangeable seals
- See Features and Benefits for additional info on pages 10 - 13.



Bearing Dimensions

Size Code	Shaft Diameter	Expansion		Fixed		A Base to Centerline Height	B Distance Between Bolt Holes		G Bolt Hole Spacing (Width)	C	D	E	F Bolts	H	L	M	N	P	Approx. Weight
		Part Number	Part Number	Mn.	Max.														
Two-Bolt Pillow Block																			
4	1 7/16	ZEPS5107	ZEP5107	1 7/8	4 3/4	6	-	7 3/8	3 9/16	2 1/4	1 1/2	1 1/8	3 7/8	2 5/16	1 3/4	1 11/16	7.40		
	35.00	ZEPS5035MM	ZEP5035MM	47.63	120.65	152.40	-	187.33	90.49	57.15	13.00	28.58	98.43	58.74	44.450	17.46	3.40		
5	1 1/2	ZEPS5108	ZEP5108	2 1/8	5 1/4	6 1/2	-	7 7/8	3 13/16	2 1/2	1 1/2	1 1/4	4 3/8	2 19/32	2 1/32	1 1/16	10.90		
	1 11/16	ZEPS5111	ZEP5111														10.50		
	40.00	ZEPS5040MM	ZEP5040MM	53.98	133.35	165.10	-	200.03	96.84	63.50	13.00	31.75	111.13	65.88	51.590	17.46	4.90		
	45.00	ZEPS5045MM	ZEP5045MM																
6	1 15/16	ZEPS5115	ZEP5115	2 1/4	6 1/16	7 1/4	-	8 7/8	3 13/16	2 1/2	5/8	1 5/16	4 9/16	2 7/8	2 5/16	1 1/16	12.10		
	2	ZEPS8200	ZEP8200														16.50		
	50.00	ZEPS5050MM	ZEP5050MM	57.15	153.99	184.15	-	225.43	96.84	63.50	16.00	33.34	115.89	73.03	58.740	17.46	5.50		
7	2	ZEPS5200	ZEP5200	2 1/2	6 9/16	8	-	9 5/8	4 1/8	2 9/16	5/8	1 1/2	5	3 1/4	2 5/8	1 3/16	16.50		
	2 3/16	ZEPS5203	ZEP5203														15.90		
	55.00	ZEPS5055MM	ZEP5055MM	63.50	166.69	203.20	-	244.48	104.78	65.09	16.00	38.10	127.00	82.60	66.680	20.64	7.20		
8	2 7/16	ZEPS5207	ZEP5207	2 3/4	6 15/16	8 3/4	-	10 1/2	4 3/8	2 11/16	5/8	1 5/8	5 1/2	3 9/16	2 29/32	7/8	19.30		
	60.00	ZEPS5060MM	ZEP5060MM	69.85	176.21	222.25	-	266.70	111.13	68.26	16.00	41.28	139.70	90.50	73.820	22.23	8.70		
	65.00	ZEPS5065MM	ZEP5065MM														8.60		
9	2 1/2	ZEPS5208	ZEP5208														31.50		
	2 11/16	ZEPS5211	ZEP5211														30.50		
	2 3/4	ZEPS5212	ZEP5212	3 1/8	7 13/16	9 3/4	-	11 13/16	4 7/8	3 3/16	3/4	1 7/8	6 5/16	4 1/16	3 3/8	7/8	30.20		
	2 15/16	ZEPS5215	ZEP5215														30.10		
	70.00	ZEPS5070MM	ZEP5070MM	79.38	198.44	247.65	-	300.04	123.83	80.96	19.00	47.63	160.34	103.20	85.730	22.23	13.70		
10	75.00	ZEPS5075MM	ZEP5075MM														13.50		
	3 3/16	ZEPS5303	ZEP5303	3 3/4	9 5/16	11 5/16	-	13 13/16	5 5/16	3 1/2	7/8	2 1/4	7 1/2	4 29/32	3 31/32	1 5/16	47.10		
	3 7/16	ZEPS5307	ZEP5307														44.70		
	80.00	ZEPS5080MM	ZEP5080MM	95.25	236.54	287.34	-	350.84	134.94	88.90	22.00	57.15	190.50	124.62	100.790	23.81	21.30		
	85.00	ZEPS5085MM	ZEP5085MM														20.30		
90.00	ZEPS5090MM	ZEP5090MM														20.00			
Four-Bolt Pillow Block																			
8	2 7/16	ZEPS5207F	ZEP5207F	2 3/4	6 15/16	8 3/4	1 7/8	10 1/2	4 3/8	3 5/8	5/8	1 5/8	5 1/2	3 9/16	2 29/32	7/8	19.40		
	60.00	ZEPS5060MMF	ZEP5060MMF	69.85	176.21	222.25	47.63	266.70	111.13	92.08	16.00	41.28	139.70	90.50	73.820	22.23	8.80		
	65.00	ZEPS5065MMF	ZEP5065MMF														8.70		
9	2 1/2	ZEPS5208F	ZEP5208F														31.00		
	2 11/16	ZEPS5211F	ZEP5211F	3 1/8	7 13/16	9 7/8	2 1/8	11 13/16	4 7/8	4 1/4	5/8	1 7/8	6 5/16	4 1/16	3 3/8	7/8	30.00		
	2 3/4	ZEPS5212F	ZEP5212F														29.80		

Continued...



Continued...

Bearing Dimensions

Size Code	Shaft Diameter	Expansion		Fixed		A Base to Centerline Height	B Distance Between Bolt Holes		G Bolt Hole Spacing (Width)	C	D	E	F Bolts	H	L	M	N	P	Approx. Weight
		Part Number	Part Number	Min.	Max.														
Four-Bolt Pillow Block (continued)																			
9	2 15/16	ZEPS5215F	ZEP5215F	3 1/8	7 13/16	9 7/8	2 1/8	11 13/16	4 7/8	4 1/4	5/8	1 7/8	6 5/16	4 1/16	3 3/8	7/8			29.70
	70.00	ZEPS5070MMF	ZEP5070MMF	79.38	198.44	250.83	53.98	300.04	123.83	107.95	16.00	47.63	160.34	103.20	85.730	22.23			13.40
	75.00	ZEPS5075MMF	ZEP5075MMF																13.20
10	3 3/16	ZEPS5303F	ZEP5303F	3 3/4	9 5/16	11 5/16	2 3/8	13 13/16	5 5/16	4 3/4	3/4	2 1/4	7 1/2	4 29/32	3 31/32	15/16			47.60
	3 7/16	ZEPS5307F	ZEP5307F																45.20
	80.00	ZEPS5080MMF	ZEP5080MMF																21.60
	85.00	ZEPS5085MMF	ZEP5085MMF	95.25	236.54	287.34	60.33	350.84	134.94	120.65	19.00	57.15	190.50	124.62	100.790	23.81			20.50
	90.00	ZEPS5090MMF	ZEP5090MMF																
11	3 11/16	ZEPS5311F	ZEP5311F	4 1/4	12	13	2 1/4	15 1/4	6 1/8	4 1/2	3/4	2 5/8	8 5/8	5 5/8	4 9/16	1 1/32			65.50
	3 15/16	ZEPS5315F	ZEP5315F																64.80
	4	ZEPS5400F	ZEP5400F																63.50
	100.00	ZEPS5100MMF	ZEP5100MMF	107.95	304.80	330.20	57.15	387.35	155.58	114.30	19.00	66.68	219.08	142.90	115.890	26.19			30.00
12	4 3/16	ZEPS5403YF	ZEP5403YF	4 3/4	12 7/8	14 1/8	2 1/2	16 1/2	6 1/4	4 5/8	3/4	2 3/4	9 3/8	6 3/16	5 1/32	1 1/16			81.00
	4 7/16	ZEPS5407YF	ZEP5407YF																78.00
	4 1/2	ZEPS5408YF	ZEP5408YF																76.00
	110.00	ZEPS5110MMF	ZEP5110MMF	120.65	327.03	358.78	63.50	419.10	158.75	117.48	19.00	69.85	238.13	157.16	127.790	26.99			35.40
	115.00	ZEPS5115MMF	ZEP5115MMF																34.50
13	4 15/16	ZEPS5415F	ZEP5415F	5 1/2	14 7/8	16 1/8	2 3/4	18 1/2	7 7/8	5 9/16	7/8	3	11 1/8	7 1/16	5 3/4	1 5/32			150.00
	5	ZEPS5500F	ZEP5500F																147.00
	125.00	ZEPS5125MMF	ZEP5125MMF	139.70	377.83	409.58	69.85	469.90	200.03	141.29	22.00	76.20	282.58	179.39	146.050	29.37			68.00
	130.00	ZEPS5130MMF	ZEP5130MMF																66.70

Additional Notes

- Please call 1-866-REXNORD for availability
- Metric bore sizes available, see the Rex Interchangeability guide
- Lubrication fitting tap size: for size code 4 thru 11, 1/8" PT; for all other size codes, 1/4" PT
- Base to centerline tolerance, +/- .005 in (+/- 0.13 mm)
- Bore size = nominal shaft size +.001 in/- .000 in (+0.03 mm/-0.00 mm)
- Seals - To specify G, K or M seal, replace "Z" in part number with "G", "K" or "M"

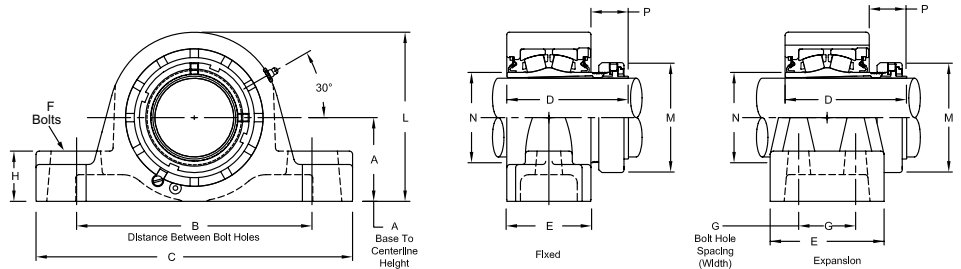
- "K" seals only available in size codes 4 thru 11
- Auxiliary end caps - available in all size codes, expect expansion units
- For the Selection Guide, Load Ratings and Speed Limits, see the Spherical Roller Bearings Engineering section on pages 15 - 27.
- Note: Dimensions subject to change. Certified dimensions of ordered material furnished on request.

ZEP6000, ZEPS6000

Interchange: EP2BIP, EP4BIP, (F)SYE-N, USRBE5000A, QVVP, QVVPR, DVP



Photo Shows a 2-Bolt Spherical Roller Bearing Pillow Block Unit



Product Features

- Spyglass Optical Strain Sensor (OSS) Technology
- Positive locking system
- Tapered adapter sleeve
- Corrosion-resistant powder coating
- Cast iron housing
- Misalignment capabilities - total of 4°
- Broad range of sealing options
- Factory set clearance & lubrication
- Precision ground & superfinished raceways
- See Features and Benefits for additional info on pages 10 - 13.

Bearing Dimensions

Size Code	Shaft Diameter	Expansion		Fixed		A Base to Centerline Height	B Distance Between Bolt Holes		G Bolt Hole Spacing (Width)	C	D	E	F Bolts	H	L	M	N	P	Approx. Weight
		Part Number	Part Number	Min.	Max.														
Two-Bolt Pillow Block																			
4	1 7/16	ZEPS6107	ZEP6107	1 7/8	4 3/4	6	-	7 3/8	3 21/64	2 1/4	1/2	1 1/8	3 7/8	2 25/64	1 3/4	1 9/64	6.90		
5	1 11/16	ZEPS6111	ZEP6111	2 1/8	5 1/4	6 1/4	-	7 7/8	3 47/64	2 1/2		1 1/4	4 3/8	2 41/64	2 1/32	1 9/32	10.50		
6	1 15/16	ZEPS6115	ZEP6115	2 1/4	6 1/16	7 1/4	-	8 7/8	3 41/64	5/8	1 5/16	4 9/16	2 55/64	2 5/16	1 1/8	12.10			
	45.00	ZEPS6045MM	ZEP6045MM	57.15	153.99	184.15	-	225.43	92.47		63.50	33.34	115.89	72.63	58.740	28.58	5.50		
7	2 3/16	ZEPS6203	ZEP6203	2 1/2	6 9/16	8	-	9 5/8	3 41/16	2 9/16	5/8	1 1/2	5	3 15/64	2 5/8	1 5/32	16.50		
	55.00	ZEPS6055MM	ZEP6055MM	63.50	166.69	203.20	-	244.48	93.66	65.09	16.00	38.10	127.00	82.15	66.680	29.37	7.20		
8	2 7/8	ZEPS6206	ZEP6206	2 3/4	6 15/16	8 3/4	-	10 1/2	4 1/16	2 11/16	5/8	1 5/8	5 1/2	3 19/32	2 29/32	1 27/64	19.30		
	2 7/16	ZEPS6207	ZEP6207														18.50		
	60.00	ZEPS6060MM	ZEP6060MM	69.85	176.21	222.25	-	266.70	103.19	68.26	16.00	41.28	139.70	91.28	73.820	36.12	8.70		
	2 11/16	ZEPS6211	ZEP6211	3 1/8	7 13/16	9 3/4	-	11 13/16	4 17/32	3 3/16	3/4	1 7/8	6 5/16	4 3/32	3 3/8	1 25/64	31.50		
2 3/4	ZEPS6212	ZEP6212	31.00																
9	2 15/16	ZEPS6215	ZEP6215	79.38	198.44	247.65	-	300.04	115.09	80.96	19.00	47.63	160.34	103.98	85.730	35.32	28.70		
	70.00	ZEPS6070MM	ZEP6070MM														13.70		
	75.00	ZEPS6075MM	ZEP6075MM	75.00	198.44	247.65	-	300.04	115.09	80.96	19.00	47.63	160.34	103.98	85.730	35.32	13.50		
10	3 3/16	ZEPS6303	ZEP6303	3 3/4	9 5/16	11 5/16	-	13 13/16	5 1/32	3 1/2	7/8	2 1/4	7 1/2	4 61/64	3 31/32	1 19/32	47.10		
	3 7/16	ZEPS6307	ZEP6307														44.70		
	80.00	ZEPS6080MM	ZEP6080MM	95.25	236.54	287.34	-	350.84	127.79	88.90	22.00	57.15	190.50	125.81	100.790	40.48	21.30		
Four-Bolt Pillow Block																			
8	2 3/8	ZEPS6206F	ZEP6206F	2 3/4	6 15/16	8 3/4	1 7/8	10 1/2	4 1/16	3 5/8	5/8	1 5/8	5 1/2	3 19/32	2 29/32	1 27/64	19.40		
	2 7/16	ZEPS6207F	ZEP6207F														18.30		
	60.00	ZEPS6060MMF	ZEP6060MMF	69.85	176.21	222.25	47.63	266.70	103.19	92.08	16.00	41.28	139.70	91.28	73.820	36.12	8.80		
9	2 11/16	ZEPS6211F	ZEP6211F	3 1/8	7 13/16	9 3/4	2 1/8	11 13/16	4 17/32	4 1/4	5/8	1 7/8	6 5/16	4 3/32	3 3/8	1 25/64	31.00		
	2 3/4	ZEPS6212F	ZEP6212F														30.50		
	2 15/16	ZEPS6215F	ZEP6215F	79.38	198.44	250.83	53.98	300.04	115.09	107.95	16.00	47.63	160.34	103.98	85.730	35.32	28.20		
	70.00	ZEPS6070MMF	ZEP6070MMF														13.40		
	75.00	ZEPS6075MMF	ZEP6075MMF	75.00	198.44	250.83	53.98	300.04	115.09	107.95	16.00	47.63	160.34	103.98	85.730	35.32	13.20		
10	3 3/16	ZEPS6303F	ZEP6303F	3 3/4	9 5/16	11 5/16	2 3/8	13 13/16	5 1/32	4 3/4	3/4	2 1/4	7 1/2	4 61/64	3 31/32	1 19/32	47.60		
	3 7/16	ZEPS6307F	ZEP6307F														45.20		
	80.00	ZEPS6080MMF	ZEP6080MMF	95.25	236.54	287.34	60.33	350.84	127.79	120.65	19.00	57.15	190.50	125.81	100.790	40.48	21.60		
	85.00	ZEPS6085MMF	ZEP6085MMF	95.25	236.54	287.34	60.33	350.84	127.79	120.65	19.00	57.15	190.50	125.81	100.790	40.48	20.50		
11	3 11/16	ZEPS6311F	ZEP6311F	4 1/4	12	13	2 1/4	15 1/4	5 25/32	4 1/2	3/4	2 5/8	8 5/8	5 43/64	4 9/16	1 47/64	65.50		
	3 15/16	ZEPS6315F	ZEP6315F														64.80		
	90.00	ZEPS6090MMF	ZEP6090MMF	107.95	304.80	330.20	57.15	387.35	146.84	114.30	19.00	66.68	219.08	144.07	115.890	44.05	30.00		
	100.00	ZEPS6100MMF	ZEP6100MMF	107.95	304.80	330.20	57.15	387.35	146.84	114.30	19.00	66.68	219.08	144.07	115.890	44.05	30.00		
12	4 3/16	ZEPS6403YF	ZEP6403YF	4 3/4	12 7/8	14 1/8	2 1/2	16 1/2	6 1/4	4 5/8	3/4	2 3/4	9 3/8	6 1/16	5 1/32	1 7/8	81.00		
	4 7/16	ZEPS6407YF	ZEP6407YF														78.00		
	110.00	ZEPS6110MMF	ZEP6110MMF	120.65	327.03	358.78	63.50	419.10	158.75	117.48	19.00	69.85	238.13	153.99	127.790	47.63	35.40		
13	4 15/16	ZEPS6415F	ZEP6415F	5 1/2	14 7/8	16 1/8	2 3/4	18 1/2	7 15/16	5 9/16	7/8	3	11 1/8	6 61/64	5 3/4	2 1/4	150.00		
	125.00	ZEPS6125MMF	ZEP6125MMF														68.00		

Additional Notes

- Please call 1-866-REXNORD for availability
- Metric bore sizes available, see the Rex Interchangeability guide
- Lubrication fitting tap size: for size code 6 thru 11, 1/8" PT; for all other size codes, 1/4" PT
- Base to centerline tolerance, +/- .005 in (+/- 0.13 mm)
- Seals - To specify G, K or M seal, replace "Z" in part number with "G", "K" or "M"

- "K" seals only available in size codes 4 thru 11
- Auxiliary end caps - available in all size codes, except expansion units
- For the Selection Guide, Load Ratings and Speed Limits, see the Spherical Roller Bearings Engineering section on pages 15 - 27.
- Note: Dimensions subject to change. Certified dimensions of ordered material furnished on request.

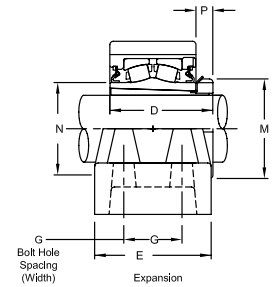
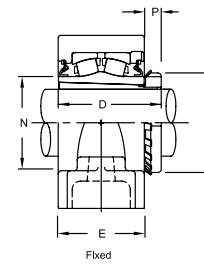
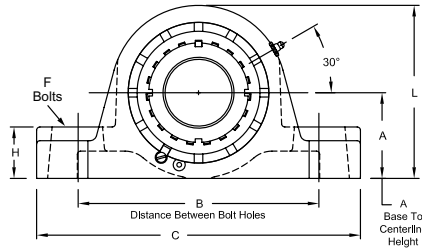
ZEP9000, ZE9000



Photo Shows a 2-Bolt Spherical Roller Bearing Pillow Block Unit

Product Features

- Corrosion-resistant powder coating
- Cast iron housing
- Misalignment capabilities - total of 4°
- Broad range of sealing options
- Factory set clearance & lubrication
- Precision ground & superfinished raceways
- Enhanced life mounting style
- Field interchangeable seals
- See Features and Benefits for additional info on pages 10 - 13.



Bearing Dimensions

Size Code	Shaft Diameter	Expansion		Fixed		A Base to Centerline Height	B Distance Between Bolt Holes		G Bolt Hole Spacing (Width)	C	D	E	F Bolts	H	L	M	N	P	Approx. Weight
		Part Number	Part Number	Min.	Max.														
Two-Bolt Pillow Block																			
7	1 15/16	ZEPS9115	ZEP9115	2 1/2	6 9/16	8	-	9 5/8	3 5/32	2 9/16	5/8	1 1/2	5	2 31/32	2 5/8	1 9/32	15.00		
	2	ZEPS9200	ZEP9200															14.90	
	45.00	ZEPS9045MM	ZEP9045MM															6.80	
	50.00	ZEPS9050MM	ZEP9050MM															6.60	
8	2 3/16	ZEPS9203	ZEP9203	2 3/4	6 15/16	8 3/4	-	10 1/2	3 11/32	2 11/16	5/8	1 5/8	5 1/2	3 3/8	2 29/32	23/32	18.60		
	55.00	ZEPS9055MM	ZEP9055MM	69.85	176.21	222.25	-	266.70	84.93	68.26	16.00	41.28	139.70	85.73	73.820	18.26	8.40		
9	2 7/16	ZEPS9207	ZEP9207	3 1/8	7 13/16	9 3/4	-	11 13/16	3 3/4	3 3/16	3/4	1 7/8	6 5/16	3 5/8	3 3/8	5/8	28.10		
	2 1/2	ZEPS9208	ZEP9208															27.70	
10	2 11/16	ZEPS9211	ZEP9211	3 3/4	9 5/16	11 5/16	-	13 13/16	4 1/4	3 1/2	7/8	2 1/4	7 1/2	4 13/32	3 31/32	13/16	45.70		
	2 15/16	ZEPS9215	ZEP9215															44.50	
	75.00	ZEPS9075MM	ZEP9075MM															95.25	236.54
Four-Bolt Pillow Block																			
8	2 3/16	ZEPS9203F	ZEP9203F	2 3/4	6 15/16	8 3/4	1 7/8	10 1/2	3 11/32	3 5/8	5/8	1 5/8	5 1/2	3 3/8	2 29/32	23/32	18.70		
	55.00	ZEPS9055MMF	ZEP9055MMF	69.85	176.21	222.25	47.63	266.70	84.93	92.08	16.00	41.28	139.70	85.73	73.820	18.26	8.50		
9	2 7/16	ZEPS9207F	ZEP9207F	3 1/8	7 13/16	9 7/8	2 1/8	11 13/16	3 3/4	4 1/4	5/8	1 7/8	6 5/16	3 5/8	3 3/8	5/8	27.60		
	2 1/2	ZEPS9208F	ZEP9208F															27.20	
10	2 11/16	ZEPS9211F	ZEP9211F	3 3/4	9 5/16	11 5/16	2 3/8	13 13/16	4 1/4	4 3/4	3/4	2 1/4	7 1/2	4 13/32	3 31/32	13/16	46.20		
	2 15/16	ZEPS9215F	ZEP9215F															45.00	
	75.00	ZEPS9075MMF	ZEP9075MMF															95.25	236.54
11	3 3/16	ZEPS9303F	ZEP9303F	4 1/4	12	13	2 1/4	15 1/4	5	4 1/2	3/4	2 5/8	8 5/8	5 3/16	4 9/16	15/16	70.00		
	3 7/16	ZEPS9307F	ZEP9307F															68.00	
	80.00	ZEPS9080MMF	ZEP9080MMF															107.95	304.80
12	3 11/16	ZEPS9311YF	ZEP9311YF	4 3/4	12 7/8	14 1/8	2 1/2	16 1/2	5 17/32	4 5/8	3/4	2 3/4	9 3/8	5 23/32	5 1/32	1 1/32	78.20		
	3 15/16	ZEPS9315YF	ZEP9315YF															75.90	
	4	ZEPS9400YF	ZEP9400YF															75.40	
	100.00	ZEPS9100MMF	ZEP9100MMF	120.65	327.03	358.78	63.50	419.10	140.49	117.48	19.00	69.85	238.13	145.26	127.790	26.19	34.40		
13	4 3/16	ZEPS9403F	ZEP9403F	5 1/2	14 7/8	16 1/8	2 3/4	18 1/2	6 3/4	5 9/16	7/8	3	11 1/8	6 1/8	5 3/4	1 1/8	150.00		
	4 7/16	ZEPS9407F	ZEP9407F															148.00	

Additional Notes

- Please call 1-866-REXNORD for availability
- Lubrication fitting tap size: for size code 7 thru 11, 1/8" PT; for all other size codes, 1/4" PT
- Base to centerline tolerance, +/- .005 in (+/- 0.13 mm)
- Seals - To specify G, K or M seal, replace "Z" in part number with "G", "K" or "M"
- "K" seals only available in size codes 7 thru 11
- Auxiliary end caps - available in all size codes, except expansion units

For the Selection Guide, Load Ratings and Speed Limits, see the Spherical Roller Bearings Engineering section on pages 15 - 27.

Note: Dimensions subject to change. Certified dimensions of ordered material furnished on request.

ZB2000, ZBS2000

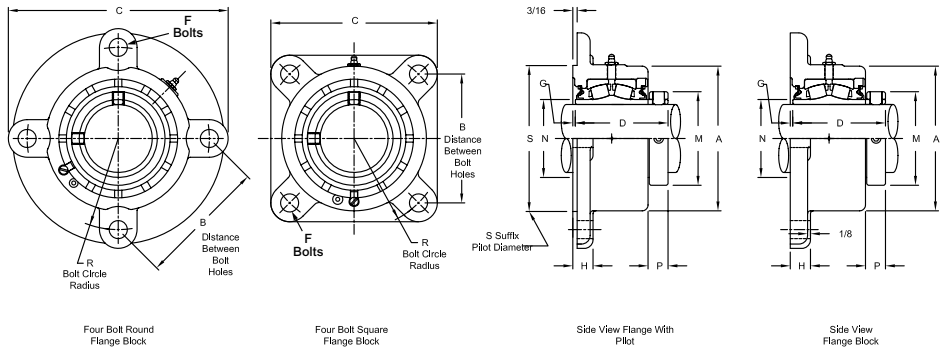
Interchange: F4RS2, F4SS2, FYR, USFB5000, QAFY, QAFL



Photo Shows a 4-Bolt Spherical Roller Bearing Flanged Unit

Product Features

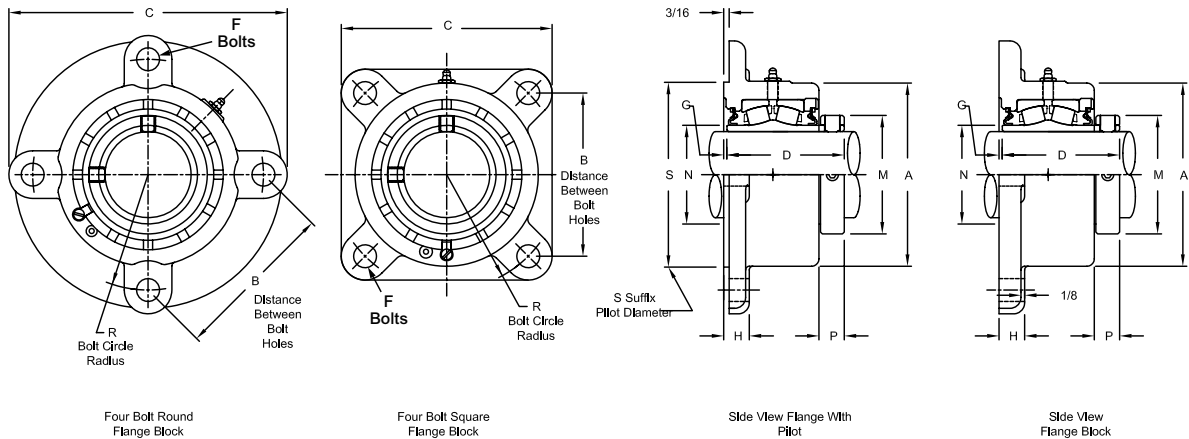
- Corrosion-resistant powder coating
- Cast iron housing
- Misalignment capabilities - total of 4°
- Broad range of sealing options
- Factory set clearance & lubrication
- Precision ground & superfinished raceways
- Hardened spring locking collar
- Field interchangeable seals
- See Features and Benefits for additional info on pages 10 - 13.



Bearing Dimensions

Size Code	Shaft Diameter	Expansion			Fixed			B Distance Between Bolt Holes	R Bolt Circle Radius	C	D	F Bolts	G	M	N	P	S	Approx. Weight
		Part Number	A	H	Part Number	A	H											
3-Bolt																		
2	3/4	-	-	-	ZB2012													4.30
	15/16	-	-	-	ZB2015	2 7/8	9/16	3 37/64	2 1/16	5 1/8	2 9/16	3/8	1/32	1 3/4	1 5/16	9/16	3	4.20
	1	-	-	-	ZB2100													
3	25.00	-	-	-	ZB2025MM	73.03	14.29	90.88	52.39	130.18	65.09	10.00	0.79	44.45	33.340	14.29	76.200	1.90
	1 1/8	-	-	-	ZB2102													5.20
	1 3/16	-	-	-	ZB2103	3 1/8	19/32	3 57/64	2 1/4	5 1/2	2 11/16	3/8	1/32	1 31/32	1 17/32	9/16	3 1/4	5.10
	1 1/4	-	-	-	ZB2104													5.00
4	30.00	-	-	-	ZB2030MM	79.38	15.09	98.83	57.15	139.70	68.26	10.00	0.79	50.00	38.880	14.29	82.550	2.30
	1 7/16	ZBS2107	3 3/4	5/8	ZB2107	3 7/16	5/8	4 21/64	2 1/2	6 1/4	2 7/8	1/2	1/32	2 5/16	1 3/4	11/16	3 9/16	6.80
	1 1/2	ZBS2108			ZB2108													6.70
	35.00	ZBS2035MM	95.25	15.88	ZB2035MM	87.31	15.88	109.93	63.50	158.75	73.02	13.00	0.79	58.74	44.450	17.46	90.490	3.10
4-Bolt Round																		
5	1 11/16	ZBS2111	4 1/4	5/8	ZB2111	3 15/16	5/8	3 57/64	2 3/4	6 3/4	3 1/8	1/2	1/32	2 19/32	2 1/32	11/16	4 1/16	8.60
	1 3/4	ZBS2112			ZB2112													8.40
	40.00	ZBS2040MM	107.95	15.88	ZB2040MM	100.01	15.88	98.83	69.85	171.45	79.38	13.00	0.79	65.88	51.580	17.46	103.190	4.00
	45.00	ZBS2045MM			ZB2045MM													8.40
6	1 15/16	ZBS2115	4 1/2	11/16	ZB2115	4 1/4	11/16	4 1/16	2 7/8	7	3 1/8	1/2	1/16	2 7/8	2 5/16	11/16	4 3/8	9.80
	2	ZBS2200			ZB2200													9.60
	50.00	ZBS2050MM	114.30	17.46	ZB2050MM	107.95	17.46	103.19	73.03	177.80	79.38	13.00	1.59	73.03	58.740	17.46	111.130	4.50
	2 3/16	ZBS2203	4 7/8	11/16	ZB2203	4 7/8	11/16	4 1/2	3 3/16	7 3/4	3 5/16	5/8	3/32	3 1/4	2 5/8	13/16	5	13.30
7	2 1/4	ZBS2204			ZB2204													13.10
	55.00	ZBS2055MM	123.83	17.46	ZB2055MM	123.83	17.46	114.30	80.96	196.85	84.14	16.00	2.38	82.55	66.680	19.84	127.000	6.10
	2 3/8	ZBS2206			ZB2206													16.70
	2 7/16	ZBS2207	5 3/8	3/4	ZB2207	5 3/8	3/4	4 49/64	3 3/8	8 1/8	3 1/2	5/8	3/32	3 9/16	2 29/32	7/8	5 7/16	16.60
8	2 1/2	ZBS2208			ZB2208													16.40
	60.00	ZBS2060MM	136.53	19.05	ZB2060MM	136.53	19.05	121.06	85.73	206.38	88.90	16.00	2.38	90.49	73.810	22.23	138.110	7.60
	65.00	ZBS2065MM			ZB2065MM													7.40
	2 11/16	ZBS2211			ZB2211													26.50
9	2 3/4	ZBS2212	6 1/4	7/8	ZB2212	6 1/4	7/8	5 9/16	3 15/16	9 1/2	4	3/4	3/32	4 1/16	3 3/8	7/8	6 5/16	26.10
	2 15/16	ZBS2215			ZB2215													25.60
	3	ZBS2300			ZB2300													25.10
	70.00	ZBS2070MM	158.75	22.23	ZB2070MM	158.75	22.23	141.29	100.01	241.30	101.60	19.00	2.38	103.19	85.730	22.23	160.340	11.80
	75.00	ZBS2075MM			ZB2075MM													11.60

Continued...



Continued...

Bearing Dimensions

Size Code	Shaft Diameter	Expansion			Fixed			B Distance Between Bolt Holes	R Bolt Circle Radius	C	D	F Bolts	G	M	N	P	S	Approx. Weight
		Part Number	A	H	Part Number	A	H											
4-Bolt Square																		
10	3 3/16	ZBS2303			ZB2303													37.00
	3 7/16	ZBS2307	7 3/8	1 3/8	ZB2307	7 3/8	1	6 23/32	4 3/4	8 7/16	4 3/8	3/4	1/4	4 29/32	3 31/32	15/16	7 3/8	34.60
	3 1/2	ZBS2308			ZB2308													34.10
	80.00	ZBS2080MM	187.33	34.93	ZB2080MM	187.33	25.40	170.66	120.65	214.31	111.13	19.00	6.35	124.62	100.810	23.81	187.330	16.80
	85.00	ZBS2085MM			ZB2085MM													
	90.00	ZBS2090MM			ZB2090MM													15.50
11	3 11/16	ZBS2311			ZB2311													59.00
	3 15/16	ZBS2315	8 3/8	1 1/2	ZB2315	8 1/2	1 3/16	7 19/32	5 3/8	9 3/4	5 1/16	7/8	1/4	5 5/8	4 9/16	1 1/32	8 1/2	56.00
	4	ZBS2400			ZB2400													
	100.00	ZBS2100MM	212.73	38.10	ZB2100MM	215.90	30.20	192.89	136.53	247.65	128.59	22.00	6.35	142.88	115.890	26.19	215.900	25.40

Additional Notes

- Please call 1-866-REXNORD for availability
- Metric bore sizes available, see Rex Interchangeability guide
- Lubrication fitting tap size, 1/8" PT
- Bore size = nominal shaft size +.001 in/-.000 in (+0.03 mm/-0.00 mm)
- Machined pilot available, add suffix S
- Seals - To specify G, K or M seal, replace "Z" in part number with "G", "K" or "M"
- Auxiliary end caps - available in all size codes except for size codes 2 thru 6 and expansion units
- "G" seals available in size codes 3 thru 11

- Also not available on size code 7 on flange side of non-piloted bearings and size code 7 thru 9 on flange side of piloted bearings
- Pilot Diameter tolerance, +.000 in/-.003 in (+0.00 mm/-0.08 mm)
- For the Selection Guide, Load Ratings and Speed Limits, see the Spherical Roller Bearings Engineering section on pages 15 - 27.
- Note: Dimensions subject to change. Certified dimensions of ordered material furnished on request.

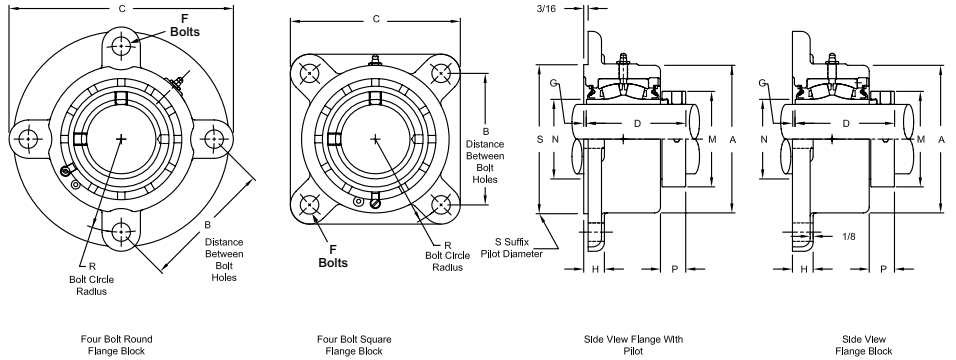
ZB3000, ZBS3000
Interchange: QMFY, QMFL



Photo Shows a 4-Bolt Spherical Roller Bearing Flanged Unit

Product Features

- Corrosion-resistant powder coating
- Cast iron housing
- Misalignment capabilities - total of 4°
- Broad range of sealing options
- Factory set clearance & lubrication
- Precision ground & superfinished raceways
- Hardened eccentric locking collar
- Field interchangeable seals
- See Features and Benefits for additional info on pages 10 - 13.



Bearing Dimensions

Size Code	Shaft Diameter	Expansion		Fixed		B Distance Between Bolt Holes	R Bolt Circle Radius	C	D	F Bolts	G	H	M	N	P	S	Approx. Weight
		Part Number	A	Part Number	A												
3-Bolt Round																	
4	1 7/16	ZBS3107	3 3/4	ZB3107	3 7/16	4 21/64	2 1/2	6 1/4	2 59/64	1/2	1/32	5/8	2 5/16	1 3/4	25/32	3 9/16	7.00
4-Bolt Round																	
5	1 11/16	ZBS3111	4 1/4	ZB3111	3 15/16	3 57/64	2 3/4	6 3/4	3 3/16	1/2	1/32	5/8	2 5/8	2 1/32	3/4	4 1/16	8.80
6	1 15/16	ZBS3115	4 1/2	ZB3115	4 1/4	4 1/16	2 7/8	7	3 9/32	1/2	1/16	11/16	2 3/4	2 5/16	27/32	4 3/8	10.00
7	2 3/16	ZBS3203	4 7/8	ZB3203	4 7/8	4 1/2	3 3/16	7 3/4	3 1/2	5/8	3/32	11/16	3 1/4	2 5/8	31/32	5	13.60
8	2 7/16	ZBS3207	5 3/8	ZB3207	5 3/8	4 49/64	3 3/8	8 1/8	3 21/32	5/8	3/32	3/4	3 9/16	2 29/32	1 1/64	5 7/16	16.80
	2 1/2	ZBS3208		ZB3208													16.60
9	2 11/16	ZBS3211	6 1/4	ZB3211	6 1/4	5 9/16	3 15/16	9 1/2	4 13/64	3/4	3/32	7/8	4 1/16	3 3/8	1 1/64	6 5/16	27.10
	2 15/16	ZBS3215		ZB3215													26.00
4-Bolt Square																	
10	3 7/16	ZBS3307	7 3/8	ZB3307	7 3/8	6 23/32	4 3/4	8 7/16	4 37/64	3/4	1/4	1	4 15/16	3 31/32	1 9/64	7 3/8	35.70
	3 1/2	ZBS3308		ZB3308													35.20
11	3 15/16	ZBS3315	8 3/8	ZB3315	8 1/2	7 19/32	5 3/8	9 3/4	5 3/16	7/8	1/4	1 1/8	5 5/8	4 9/16	1 1/16	8 1/2	56.00

Additional Notes

- Please call 1-866-REXNORD for availability
- Lubrication fitting tap size, 1/8" PT
- Bore size = nominal shaft size +.001 in/-.000 in (+0.03 mm/-0.00 mm)
- Machined pilot available, add suffix S
- Seals - To specify G, K or M seal, replace "Z" in part number with "G", "K" or "M"
- Auxiliary end caps - available in all size codes except for size codes 4 thru 6 and expansion units

- Also not available on size code 7 on flange side of non-piloted bearings and size code 7 thru 9 on flange side of piloted bearings
- Pilot Diameter tolerance, +.000 in/-.003 in (+0.00 mm/-0.08 mm)
- For the Selection Guide, Load Ratings and Speed Limits, see the Spherical Roller Bearings Engineering section on pages 15 - 27.
- Note: Dimensions subject to change. Certified dimensions of ordered material furnished on request.

ZB5000, ZBS5000

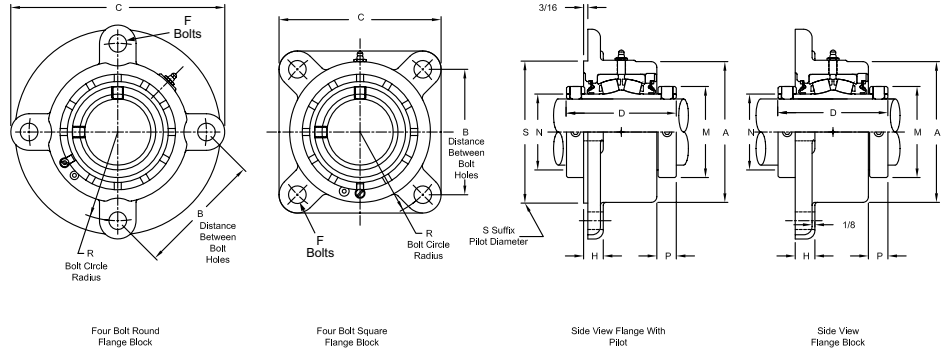
Interchange: QAAFY, QAAFL



Photo Shows a 4-Bolt Spherical Roller Bearing Flanged Unit

Product Features

- Corrosion-resistant powder coating
- Cast iron housing
- Misalignment capabilities - total of 4°
- Broad range of sealing options
- Factory set clearance & lubrication
- Precision ground & superfinished raceways
- Two hardened spring locking collars
- Field interchangeable seals
- See Features and Benefits for additional info on pages 10 - 13.



Bearing Dimensions

Size Code	Shaft Diameter	Expansion			Fixed			B Distance Between Bolt Holes	R Bolt Circle Radius	C	D	F Bolts	M	N	P	S	Approx. Weight
		Part Number	A	H	Part Number	A	H										
3-Bolt Round																	
4	1 7/16	ZBS5107	3 3/4	5/8	ZB5107	3 7/16	5/8	4 21/64	2 1/2	6 1/4	3 9/16	1/2	2 5/16	1 3/4	11/16	3 9/16	7.10
	35.00	ZBS5035MM	95.25	15.88	ZB5035MM	87.31	15.88	109.93	63.50	158.75	90.49	13.00	58.74	44.450	17.46	90.490	3.20
4-Bolt Round																	
5	1 1/2	ZBS5108	4 1/4	5/8	ZB5108	3 15/16	5/8	3 57/64	2 3/4	6 3/4	3 13/16	1/2	2 19/32	2 1/32	11/16	4 1/16	9.60
	1 11/16	ZBS5111			ZB5111												9.20
	40.00	ZBS5040MM	ZB5040MM	100.01	15.88	98.83	69.85	171.45	96.84	13.00	65.88	51.580	17.46	103.190	4.30		
	45.00	ZBS5045MM	ZB5045MM	107.95	15.88	98.83	69.85	171.45	96.84	13.00	65.88	51.580	17.46	103.190	4.20		
6	1 15/16	ZBS5115	4 1/2	11/16	ZB5115	4 1/4	11/16	4 1/16	2 7/8	7	3 13/16	1/2	2 7/8	2 5/16	11/16	4 3/8	10.40
	50.00	ZBS5050MM	114.30	17.46	ZB5050MM	107.95	17.46	103.19	73.03	177.80	96.84	13.00	73.03	58.740	17.46	111.130	4.70
7	2	ZBS5200	4 7/8	11/16	ZB5200	4 7/8	11/16	4 1/2	3 3/16	7 3/4	4 1/8	5/8	3 1/4	2 5/8	13/16	5	15.00
	2 3/16	ZBS5203			ZB5203												14.40
	55.00	ZBS5055MM	123.83	17.46	ZB5055MM	123.83	17.46	114.30	80.96	196.85	104.78	16.00	82.60	66.680	20.64	127.000	6.50
8	2 7/16	ZBS5207	5 3/8	3/4	ZB5207	5 3/8	3/4	4 49/64	3 3/8	8 1/8	4 3/8	5/8	3 9/16	2 29/32	7/8	5 7/16	17.70
	60.00	ZBS5060MM	136.53	19.05	ZB5060MM	136.53	19.05	121.06	85.73	206.38	111.13	16.00	90.50	73.810	22.23	138.110	8.10
	65.00	ZBS5065MM			ZB5065MM												8.00
9	2 1/2	ZBS5208	6 1/4	7/8	ZB5208	6 1/4	7/8	5 9/16	3 15/16	9 1/2	4 7/8	3/4	4 1/16	3 3/8	7/8	6 5/16	29.20
	2 11/16	ZBS5211			ZB5211												28.20
	2 15/16	ZBS5215	ZB5215	27.70													
	70.00	ZBS5070MM	ZB5070MM	158.75	22.23	141.29	100.01	241.30	123.83	19.00	103.20	85.730	22.23	160.340	12.80		
	75.00	ZBS5075MM	ZB5075MM	158.75	22.23	141.29	100.01	241.30	123.83	19.00	103.20	85.730	22.23	160.340	12.60		
4-Bolt Square																	
10	3 3/16	ZBS5303	7 3/8	1 3/8	ZB5303	7 3/8	1	6 23/32	4 3/4	8 7/16	5 5/16	3/4	4 29/32	3 31/32	15/16	7 3/8	39.60
	3 7/16	ZBS5307			ZB5307												37.70
	80.00	ZBS5080MM	ZB5080MM	187.33	25.40	170.66	120.65	214.31	134.94	19.00	124.62	100.810	23.81	187.330	17.00		
	85.00	ZBS5085MM	ZB5085MM	187.33	25.40	170.66	120.65	214.31	134.94	19.00	124.62	100.810	23.81	187.330	17.00		
11	90.00	ZBS5090MM	ZB5090MM	187.33	25.40	170.66	120.65	214.31	134.94	19.00	124.62	100.810	23.81	187.330	16.50		
	3 11/16	ZBS5311	8 3/8	1 1/2	ZB5311	8 1/2	1 3/16	7 19/32	5 3/8	9 3/4	6 1/8	7/8	5 5/8	4 9/16	1 1/32	8 1/2	61.50
	3 15/16	ZBS5315			ZB5315												60.50
	4	ZBS5400	ZB5400	59.50													
100.00	ZBS5100MM	ZB5100MM	212.73	38.10	192.89	136.53	247.65	155.58	22.00	142.90	115.890	26.19	215.900	27.50			

Additional Notes

- Please call 1-866-REXNORD for availability
- Metric bore sizes available, see Rex Interchangeability guide
- Lubrication fitting tap size, 1/8" PT
- Bore size = nominal shaft size +.001 in/-.000 in (+0.03 mm/-0.00 mm)
- Machined pilot available, add suffix S
- Seals - To specify G, K or M seal, replace "Z" in part number with "G", "K" or "M"
- Auxiliary end caps - available in all size codes except for size codes 4 thru 6 and expansion units

- Also not available on size code 7 on flange side of non-piloted bearings and size code 7 thru 9 on flange side of piloted bearings
- Pilot Diameter tolerance, +.000 in/-.003 in (+0.00 mm/-0.08 mm)
- For the Selection Guide, Load Ratings and Speed Limits, see the Spherical Roller Bearings Engineering section on pages 15 - 27.
- Note: Dimensions subject to change. Certified dimensions of ordered material furnished on request.

ZB6000, ZBS6000

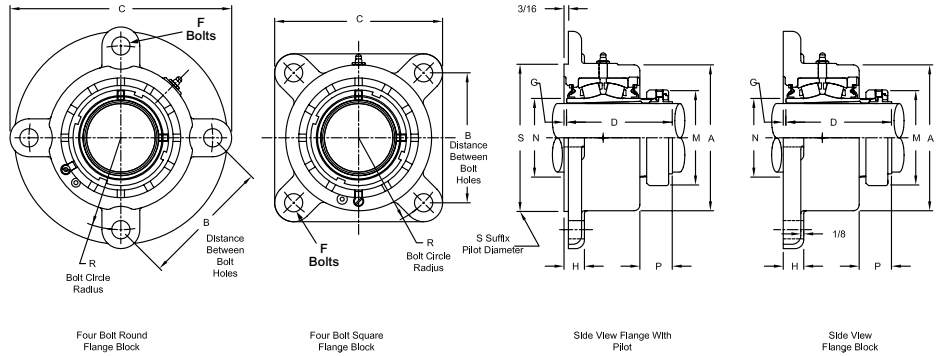
Interchange: F4RIP, F4SIP, USFB5000A, QVFL, QVVFL



Photo Shows a 4-Bolt Spherical Roller Bearing Flanged Unit

Product Features

- Spyglass Optical Strain Sensor (OSS) Technology
- Positive locking system
- Tapered adapter sleeve
- Corrosion-resistant powder coating
- Cast iron housing
- Misalignment capabilities - total of 4°
- Broad range of sealing options
- Factory set clearance & lubrication
- Precision ground & superfinished raceways
- See Features and Benefits for additional info on pages 10 - 13.



Bearing Dimensions

Size Code	Shaft Diameter	Expansion			Fixed			B Distance Between Bolt Holes	R Bolt Circle Radius	C	D	F Bolts	G	M	N	P	S	Approx. Weight
		Part Number	A	H	Part Number	A	H											
3-Bolt																		
4	1 7/16	ZBS6107	3 3/4	5/8	ZB6107	3 7/16	5/8	4 21/64	2 1/2	6 1/4	3 21/64	1/2	1/32	2 25/64	1 3/4	1 9/64	3 9/16	6.80
4-Bolt Round																		
5	1 11/16	ZBS6111	4 1/4	5/8	ZB6111	3 15/16	5/8	3 57/64	2 3/4	6 3/4	3 47/64	1/2	1/32	2 41/64	2 1/32	1 9/32	4 1/16	8.60
6	1 15/16	ZBS6115	4 1/2	11/16	ZB6115	4 1/4	11/16	4 1/16	2 7/8	7	3 41/64		1/16	2 55/64	2 5/16	1 1/8	4 3/8	9.80
	45.00	ZBS6045MM	114.30	17.46	ZB6045MM	107.95	17.46	103.19	73.03	177.80	92.47	13.00	1.59	72.63	58.740	28.58	111.130	4.20
7	2 3/16	ZBS6203	4 7/8	11/16	ZB6203	4 7/8	11/16	4 1/2	3 3/16	7 3/4	3 11/16	5/8	3/32	3 15/64	2 5/8	1 5/32	5	13.30
	55.00	ZBS6055MM	123.83	17.46	ZB6055MM	123.83	17.46	114.30	80.96	196.85	93.66	16.00	2.38	82.15	66.680	29.37	127.000	6.50
8	2 3/8	ZBS6206	5 3/8	3/4	ZB6206	5 3/8	3/4	4 49/64	3 3/8	8 1/8	4 1/16	5/8	3/32	3 19/32	2 29/32	1 27/64	5 7/16	16.70
	2 7/16	ZBS6207			ZB6207													16.60
	60.00	ZBS6060MM			136.53													19.05
9	2 11/16	ZBS6211	6 1/4	7/8	ZB6211	6 1/4	7/8	5 9/16	3 15/16	9 1/2	4 17/32	3/4	3/32	4 3/32	3 3/8	1 25/64	6 5/16	26.50
	2 3/4	ZBS6212			ZB6212													26.10
	2 15/16	ZBS6215			ZB6215													25.60
	70.00	ZBS6070MM			158.75													22.23
	75.00	ZBS6075MM			ZB6075MM													12.60
4-Bolt Square																		
10	3 3/16	ZBS6303	7 3/8	1 3/8	ZB6303	7 3/8	1	6 23/32	4 3/4	8 7/16	5 1/32	3/4	1/4	4 61/64	3 31/32	1 19/32	7 3/8	37.00
	3 7/16	ZBS6307			ZB6307													34.60
	80.00	ZBS6080MM			ZB6080MM													18.00
	85.00	ZBS6085MM			ZB6085MM													17.00
11	3 11/16	ZBS6311	8 3/8	1 1/2	ZB6311	8 1/2	1 3/16	7 19/32	5 3/8	9 3/4	5 25/32	7/8	1/4	5 43/64	4 9/16	1 47/64	8 1/2	59.00
	3 15/16	ZBS6315			ZB6315													56.00
	90.00	ZBS6090MM			ZB6090MM													27.50
	100.00	ZBS6100MM			ZB6100MM													

Additional Notes

- Please call 1-866-REXNORD for availability
- Lubrication fitting tap size, 1/8" PT
- Machined pilot available, add suffix S
- Seals - To specify G, K or M seal, replace "Z" in part number with "G", "K" or "M"
- Auxiliary end caps - available in all size codes except for size code 4 thru 6 and expansion units
- Also not available on size code 7 on flange side of non-piloted bearings and size code 7 thru 9 on flange side of piloted bearings

- Pilot Diameter tolerance, +.000 in/-0.003 in (+0.00 mm/-0.08 mm)
- For the Selection Guide, Load Ratings and Speed Limits, see the Spherical Roller Bearings Engineering section on pages 15 - 27.
- Note: Dimensions subject to change. Certified dimensions of ordered material furnished on request.

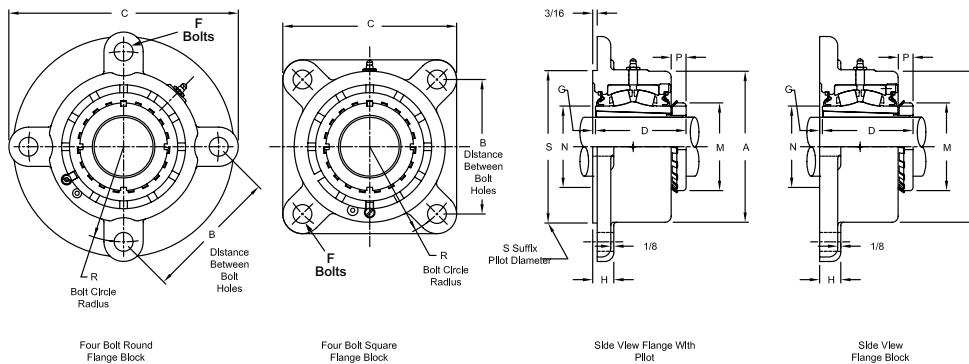
ZB9000, ZBS9000



Photo Shows a 4-Bolt Spherical Roller Bearing Flanged Unit

Product Features

- Corrosion-resistant powder coating
- Cast iron housing
- Misalignment capabilities - total of 4°
- Broad range of sealing options
- Factory set clearance & lubrication
- Precision ground & superfinished raceways
- Enhanced life mounting style
- Field interchangeable seals
- See Features and Benefits for additional info on pages 10 - 13.



Bearing Dimensions

Size Code	Shaft Diameter	Expansion			Fixed			B Distance Between Bolt Holes	R Bolt Circle Radius	C	D	F Bolts	G	M	N	P	S	Approx. Weight
		Part Number	A	H	Part Number	A	H											
4-Bolt Round																		
7	1 15/16	ZBS9115			ZB9115													13.50
	2	ZBS9200			ZB9200													13.40
	45.00	ZBS9045MM	123.83	17.46	ZB9045MM	123.83	17.46	114.30	80.96	196.85	80.17	16.00	2.38	75.40	66.680	15.08	127.000	6.40
	50.00	ZBS9050MM			ZB9050MM													6.10
8	2 3/16	ZBS9203	5 3/8	3/4	ZB9203	5 3/8	3/4	4 49/64	3 3/8	8 1/8	3 11/32	5/8	3/32	3 3/8	2 29/32	23/32	5 7/16	17.00
	55.00	ZBS9055MM	136.53	19.05	ZB9055MM	136.53	19.05	121.06	85.73	206.38	84.93	16.00	2.38	85.73	73.810	18.26	138.110	7.70
9	2 7/16	ZBS9207			ZB9207													25.80
	2 1/2	ZBS9208	6 1/4	7/8	ZB9208	6 1/4	7/8	5 9/16	3 15/16	9 1/2	3 3/4	3/4	3/32	3 5/8	3 3/8	5/8	6 5/16	25.40
4-Bolt Square																		
10	2 11/16	ZBS9211			ZB9211													38.20
	2 15/16	ZBS9215	7 3/8	1 3/8	ZB9215	7 3/8	1	6 23/32	4 3/4	8 7/16	4 1/4	3/4	1/4	4 13/32	3 31/32	13/16	7 3/8	37.00
	3	ZBS9300			ZB9300													36.50
	75.00	ZBS9075MM	187.33	34.93	ZB9075MM	187.33	25.40	170.66	120.65	214.31	107.95	19.00	6.35	111.92	100.810	20.64	187.330	16.80
11	3 3/16	ZBS9303	8 3/8	1 1/2	ZB9303	8 1/2	1 3/16	7 19/32	5 3/8	9 3/4	5	7/8	1/4	5 3/16	4 9/16	15/16	8 1/2	62.00
	3 7/16	ZBS9307			ZB9307													60.00
	80.00	ZBS9080MM	212.73	38.10	ZB9080MM	215.90	30.20	192.89	136.53	247.65	127.00	22.00	6.35	131.76	115.890	23.81	215.900	28.10

Additional Notes

- Please call 1-866-REXNORD for availability
- Lubrication fitting tap size, 1/8" PT
- Machined pilot available, add suffix S
- Seals - To specify G, K or M seal, replace "Z" in part number with "G", "K" or "M"
- Auxiliary end caps - available in all size codes except for size code 7 on flange side of non-piloted bearings and size code 7 thru 9 on flange side of piloted bearings and expansion units
- Pilot Diameter tolerance, +.000 in/-0.003 in (+0.00 mm/-0.08 mm)

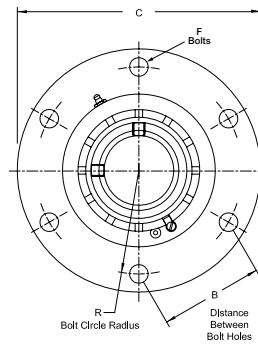
For the Selection Guide, Load Ratings and Speed Limits, see the Spherical Roller Bearings Engineering section on pages 15 - 27.

Note: Dimensions subject to change. Certified dimensions of ordered material furnished on request.

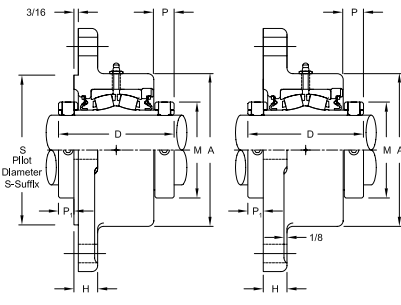
ZF5000, ZFS5000
Interchange: QAAFV



Photo Shows a 4-Bolt Spherical Roller Bearing Flanged Unit

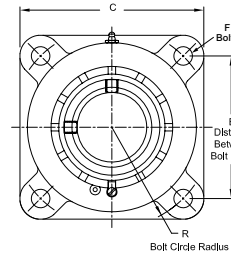


Six Bolt Round Flange Block

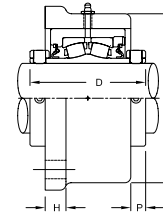


Side View Flange Block With Pilot

Full Side View Flange Block Fixed



Four Bolt Square Flange Block



Full Side View Square Flange Block Floating

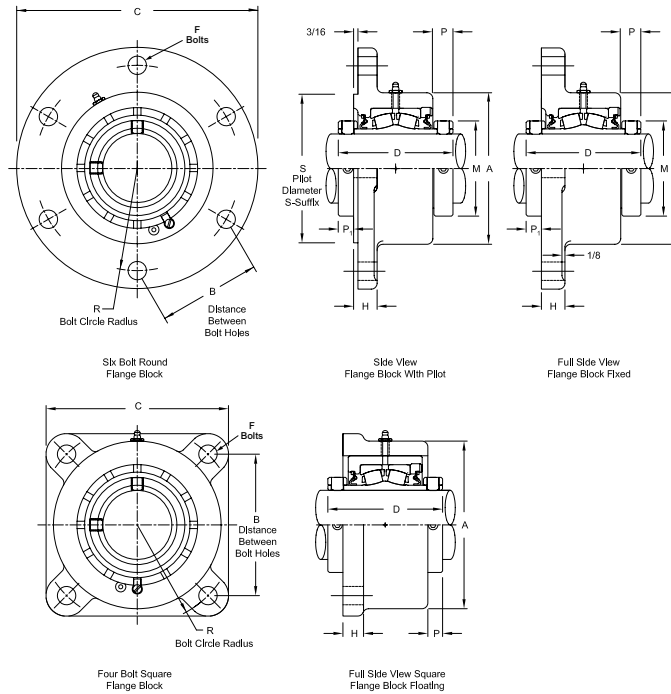
Product Features

- Corrosion-resistant powder coating
- Cast iron housing
- Misalignment capabilities - total of 4°
- Broad range of sealing options
- Factory set clearance & lubrication
- Precision ground & superfinished raceways
- Two hardened spring locking collars
- Field interchangeable seals
- Fixed or Expansion - up to 3/4" expansion
- See Features and Benefits for additional info on pages 10 - 13.

Bearing Dimensions

Size Code	Shaft Diameter	Expansion						Fixed						B Distance Between Bolt Holes	R Bolt Circle Radius	C	D	H	M	P1	
		Part Number	A	F Bolts	P	S	Approx. Weight	Part Number	A	F Bolts	P	S	Approx. Weight								
4-Bolt Square																					
4	1 7/16	ZFS5107	4 7/16	1/2	15/32	4 7/16	9.60	ZF5107	3 11/16	1/2	11/16	3 9/16	7.60	3 23/32	2 5/8	4 15/16	3 9/16	5/8	2 5/16	1/2	
		35.00	ZFS5035MM	112.71	13.00	11.89	112.710	4.40	ZF5035MM	93.66	13.00	17.46	90.490	3.40	94.46	66.68	125.41	90.49	15.88	58.74	12.70
5	1 1/2	ZFS5108	5	1/2	13/32	4 3/4	12.60	ZF5108	4 1/4	1/2	11/16	4 1/16	10.40	3 57/64	2 3/4	5 1/8	3 13/16	5/8	2 19/32	15/32	
		12.30						ZF5111													9.70
		40.00	ZFS5040MM	127.00	13.00	10.31	120.650	5.70	ZF5040MM	107.95	13.00	17.46	103.190	4.70	98.83	69.85	130.18	96.84	15.88	65.88	11.89
		45.00	ZFS5045MM					5.60	ZF5045MM					4.40							
6	1 15/16	ZFS5115	5 1/8	1/2	13/32	5 1/8	12.80	ZF5115	4 1/2	1/2	11/16	4 3/8	10.40	4 1/16	2 7/8	5 5/16	3 13/16	5/8	2 7/8	15/32	
		50.00	ZFS5050MM	130.18	13.00	10.31	130.180	5.80	ZF5050MM	114.30	13.00	17.46	111.130	4.70	103.19	73.03	134.94	96.84	15.88	73.03	11.89
7	2	ZFS5200	5 3/4	5/8	1/2	5 5/8	18.00	ZF5200	5	5/8	13/16	5	14.40	4 1/2	3 3/16	5 7/8	4 1/8	11/16	3 1/4	2 1/32	
		17.30						ZF5203													13.70
		55.00	ZFS5055MM	146.05	16.00	12.70	142.880	7.80	ZF5055MM	127.00	16.00	20.64	127.000	6.20	114.30	80.96	149.23	104.78	17.46	82.60	11.66
8	2 7/16	ZFS5207	6	5/8	3/16	6	20.30	ZF5207	5 1/2	5/8	7/8	5 7/16	17.50	5 1/32	3 9/16	6 7/16	4 3/8	3/4	3 9/16	5/8	
		9.20						ZF5060MM													7.90
		60.00	ZFS5060MM	152.40	16.00	14.29	152.400	8.70	ZF5065MM	139.70	16.00	22.23	138.110	7.50	127.80	90.49	163.51	111.13	19.05	90.50	15.88
9	2 1/2	ZFS5208	7 1/8	3/4	5/8	7 1/8	35.40	ZF5208	6 1/2	3/4	7/8	6 5/16	29.90	6 1/64	4 1/4	7 3/4	4 7/8	7/8	4 1/16	2 1/32	
		34.10						ZF5211													28.90
		33.20						ZF5215													26.90
		70.00	ZFS5070MM	180.98	19.00	15.88	180.980	15.50	ZF5070MM	165.10	19.00	22.23	160.340	13.10	152.80	107.95	196.85	123.83	22.23	103.20	16.66
		75.00	ZFS5075MM					15.10	ZF5075MM					12.20							
10	3 3/16	ZFS5303	8	3/4	9/16	8	47.00	ZF5303	7 3/8	3/4	15/16	7 3/8	40.00	6 23/32	4 3/4	8 7/16	5 5/16	1	4 29/32	1 1/16	
		45.50						ZF5307													38.00
		80.00	ZFS5080MM					21.30	ZF5080MM					18.10							
		85.00	ZFS5085MM	203.20	19.00	14.29	203.200	20.60	ZF5085MM	187.33	19.00	23.81	187.330	17.20	170.67	120.65	214.31	134.94	25.40	124.62	17.46
		90.00	ZFS5090MM					19.60	ZF5090MM					16.20							
11	3 11/16	ZFS5311	9 1/2	1	5/8	9 1/2	80.00	ZF5311	8 7/8	1	1 1/32	8 7/8	71.00	8 5/16	5 7/8	10 9/16	6 1/8	1 1/8	5 5/8	13/16	
		77.00						ZF5315													69.00
		76.00						ZF5400													68.00
		100.00						ZFS5100MM													241.30
6-Bolt Round																					
12	4 3/16	ZFS5403Y	11 5/8	1	1 1/16	11 5/8	127.00	ZF5403Y	9 1/2	1	1 1/16	10 3/8	98.00	6 7/16	6 7/16	15 1/8	6 1/4	1 1/4	6 3/16	3/4	
		124.00						ZF5407Y													96.00
		123.00						ZF5408Y													95.00
		110.00						ZFS5110MM													295.28
	115.00	ZFS5115MM						ZF5115MM					43.00								
13	4 15/16	ZFS5415	12 9/16	1	23/32	12 9/16	184.00	ZF5415	11 3/16	1 1/8	1 5/32	11 3/16	159.00	7	7	16 1/2	7 7/8	1 1/2	7 1/16	3/4	

Continued...



Continued...

Bearing Dimensions

Size Code	Shaft Diameter	Expansion						Fixed						B Distance Between Bolt Holes	R Bolt Circle Radius	C	D	H	M	P1
		Part Number	A	F Bolts	P	S	Approx. Weight	Part Number	A	F Bolts	P	S	Approx. Weight							
6-Bolt Round (continued)																				
13	5	ZFS5500	12 9/16	1	23/32	12 9/16	183.00	ZF5500	11 3/16	1 1/8	1 3/16	11 3/16	156.00	7	7	16 1/2	7 7/8	1 1/2	7 1/16	3/4
	125.00	ZFS5125MM	319.09	25.00	18.25	319.090	83.00	ZF5125MM	284.16	28.00	29.37	284.160	72.00	177.80	177.80	419.10	200.03	38.10	179.39	19.05
	130.00	ZFS5130MM						ZF5130MM					71.00							

Additional Notes

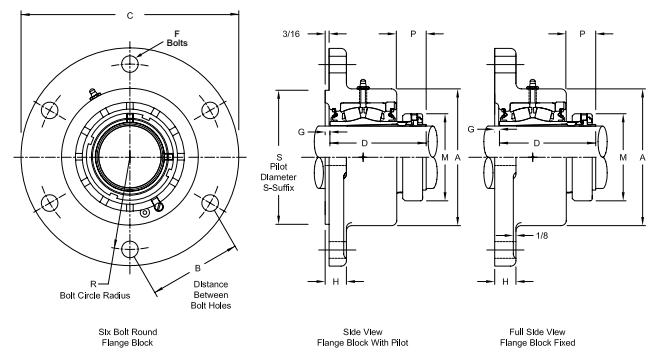
- Please call 1-866-REXNORD for availability
- Metric bore sizes available, see Rex Interchangeability guide
- Lubrication fitting tap size: for size code 4 thru 11, 1/8" PT; for all other size codes, 1/4" PT
- Bore size = nominal shaft size +.001 in/-.000 in (+0.03 mm/-0.00 mm)
- Machined pilot available, add suffix S
- Expansion - size code 4 thru 8 is 3/8", size code 9 thru 11 is 1/2" & size code 12 thru 13 is 3/4"
- Seals - To specify G, K or M seal, replace "Z" in part number with "G", "K" or "M"

- "K" seals only available in size codes 4 thru 11
- Auxiliary end caps - available in all size codes except for size codes 4 thru 6 on flange side of piloted bearings and size code 12 ZFS bearings
- Pilot Diameter tolerance, +.000 in/-.003 in (+0.00 mm/-0.08 mm)
- For the Selection Guide, Load Ratings and Speed Limits, see the Spherical Roller Bearings Engineering section on pages 15 - 27.
- Note: Dimensions subject to change. Certified dimensions of ordered material furnished on request.

ZF6000, ZFS6000
Interchange: QVFX, QVVF



Photo Shows a 4-Bolt Spherical Roller Bearing Flanged Unit



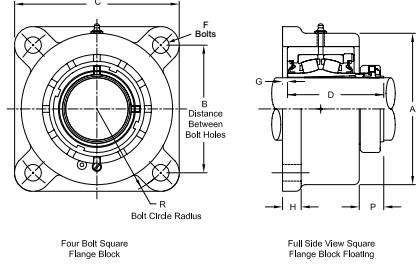
Six Bolt Round Flange Block

Side View Flange Block With Pilot

Full Side View Flange Block Fixed

Product Features

- Spyglass Optical Strain Sensor (OSS) Technology
- Positive locking system
- Tapered adapter sleeve
- Corrosion-resistant powder coating
- Cast iron housing
- Misalignment capabilities - total of 4°
- Broad range of sealing options
- Factory set clearance & lubrication
- Precision ground & superfinished raceways
- See Features and Benefits for additional info on pages 10 - 13.



Four Bolt Square Flange Block

Full Side View Square Flange Block Floating

Bearing Dimensions

Size Code	Shaft Dia.	Expansion							Fixed							B Distance Between Bolt Holes	R Bolt Circle Radius	C	D	H	M
		Part Number	A	F Bolts	G	P	S	Approx. Weight	Part Number	A	F Bolts	G	P	S	Approx. Weight						
4-Bolt Square																					
4	1 7/16	ZFS6107	4 7/16		1 5/16	1 9/64	4 7/16	7.10	ZF6107	4 7/16		1 9/32	1 9/64	3 9/16	7.10	3 23/32	2 5/8	4 15/16	3 21/64	2 25/64	
5	1 11/16	ZFS6111	5	1/2	1 1/2	1 9/32	4 3/4	9.10	ZF6111	4 3/4	1/2	1 27/64	1 9/32	4 1/16	9.10	3 57/64	2 3/4	5 1/8	3 47/64	5/8	2 41/64
6	1 15/16	ZFS6115	5 1/8		1 1/2	1	5 1/8	12.80	ZF6115	4 1/2		1 3/8	1 1/8	4 3/8	10.40	4 1/16	2 7/8	5 9/16	3 41/64	2 55/64	
	45.00	ZFS6045MM	130.18	13.00	25.40	130.180	5.80	ZF6045MM	114.30	13.00	28.58	111.130	4.70	103.19	73.03	134.94	92.47	15.88	72.63		
7	2 3/16	ZFS6203	5 3/4	5/8	1 9/16	1 1/16	5 5/8	17.30	ZF6203	5	5/8	1 27/64	1 5/32	5	13.70	4 1/2	3 3/16	5 7/8	3 11/16	1 1/16	3 15/64
	55.00	ZFS6055MM	146.05	16.00	26.99	142.880	7.80	ZF6055MM	127.00	16.00	29.37	127.000	6.20	114.30	80.96	149.23	93.66	17.46	82.15		
8	2 3/8	ZFS6206	6	5/8	1 5/8	1 19/64	6	20.60	ZF6206	5 1/2	5/8	1 27/64	5 7/16	17.80	5 1/32	3 9/16	6 7/16	4 1/16	3/4	3 19/32	
	27.16	ZFS6207			32.94	152.400	9.20	ZF6060MM	139.70	16.00	36.12	138.110	7.90	127.80	90.49	163.51	103.19	19.05	91.28		
9	2 11/16	ZFS6211						35.40	ZF6211					29.90							
	2 3/4	ZFS6212	7 1/8	3/4	1 17/64	7 1/8		34.70	ZF6212	6 1/2	3/4	1 25/64	6 5/16	29.20	6 1/64	4 1/4	7 3/4	4 17/32	7/8	4 3/32	
	2 15/16	ZFS6215			1 13/16			34.10	ZF6215			1 51/64		28.90							
	70.00	ZFS6070MM	180.98	19.00	32.15	180.980	15.50	ZF6070MM	165.10	19.00	35.32	160.340	13.10	152.80	107.95	196.85	115.09	22.23	103.98		
10	3 3/16	ZFS6303	8	3/4	2 3/32	1 15/32	8	47.00	ZF6303	7 3/8	3/4	1 19/32	7 3/8	40.00	6 23/32	4 3/4	8 7/16	5 1/32	1	4 61/64	
	3 7/16	ZFS6307						45.50	ZF6307			1 31/32		38.00							
	80.00	ZFS6080MM	203.20	19.00	37.31	203.200	21.30	ZF6080MM	187.33	19.00	40.48	187.330	18.10	170.67	120.65	214.31	127.79	25.40	125.81		
	85.00	ZFS6085MM					20.60	ZF6085MM					17.20								
11	3 11/16	ZFS6311	9 1/2	1	2 7/16	1 39/64	9 1/2	80.00	ZF6311	8 7/8	1	2 5/16	1 47/64	8 7/8	71.00	8 5/16	5 7/8	10 9/16	5 25/32	1 1/8	5 43/64
	3 15/16	ZFS6315						77.00	ZF6315					69.00							
	90.00	ZFS6090MM	241.30	25.00			241.300	35.00	ZF6090MM	225.43	25.00			225.430	31.30	211.14	149.23	268.29	146.84	28.58	144.07
	100.00	ZFS6100MM							ZF6100MM												
6-Bolt Round																					
12	4 3/16	ZFS6403Y	11 5/8	1	2 7/16	1 3/4	11 5/8	127.00	ZF6403Y	9 1/2	1	2 3/8	1 7/8	10 3/8	98.00	6 7/16	6 7/16	15 1/8	6 1/4	1 1/4	6 1/16
	110.00	ZFS6110MM	295.28	25.00	44.45	295.280	56.00	ZF6110MM	241.30	25.00	47.63	263.530	43.50	163.51	163.51	384.18	158.75	31.75	153.99		
13	4 15/16	ZFS6415	12 9/16	1	3 7/32	2 1/64	12 9/16	184.00	ZF6415	11 3/16	1 1/8	3 3/16	2 1/4	11 3/16	159.00	7	7	16 1/2	7 15/16	1 1/2	6 61/64
	125.00	ZFS6125MM	319.09	25.00		319.090	83.00	ZF6125MM	284.16	28.00			284.160	72.00	177.80	177.80	419.10	201.61	38.10	176.61	

Additional Notes

- Please call 1-866-REXNORD for availability
- Lubrication fitting tap size: for size code 6 thru 11, 1/8" PT: for all other size codes, 1/4" PT
- Machined pilot available, add suffix S
- Expansion - size code 6 thru 8 is 3/8", size code 9 thru 11 is 1/2" & size code 12 thru 13 is 3/4"
- Seals - To specify G, K or M seal, replace "Z" in part number with "G", "K" or "M"
- "K" seals only available in size codes 4 thru 11

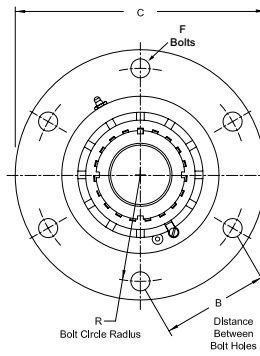
- Auxiliary end caps - available in all size codes except for size code 6 on flange side of piloted bearings and size code 12 ZFS bearings
- For the Selection Guide, Load Ratings and Speed Limits, see the Spherical Roller Bearings Engineering section on pages 15 - 27.
- Note: Dimensions subject to change. Certified dimensions of ordered material furnished on request.

ZF9000, ZFS9000

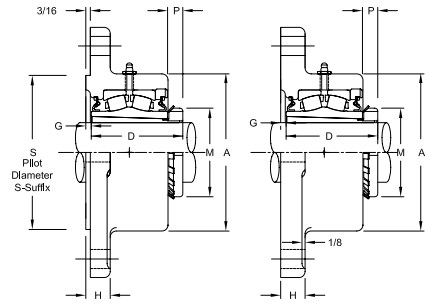
Interchange: QVFK, QVVFK, TAFK



Photo Shows a 4-Bolt Spherical Roller Bearing Flanged Unit



Six Bolt Round Flange Block

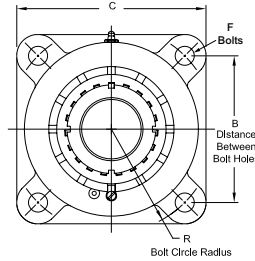


Side View Flange Block With Pilot

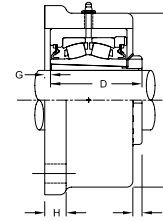
Full Side View Flange Block Fixed

Product Features

- Corrosion-resistant powder coating
- Cast iron housing
- Misalignment capabilities - total of 4°
- Broad range of sealing options
- Factory set clearance & lubrication
- Precision ground & superfinished raceways
- Enhanced life mounting style
- Field interchangeable seals
- Fixed or Expansion - up to 3/4" expansion
- See Features and Benefits for additional info on pages 10 - 13.



Four Bolt Square Flange Block



Full Side View Square Flange Block Floating

Bearing Dimensions

Size Code	Shaft Diameter	Flange Block - Expansion							Flange Block - Fixed							B Distance Between Bolt Holes	R Bolt Circle Radius	C	D	H	M
		Part Number	A	F Bolts	G	P	S	Approx. Weight	Part Number	A	F Bolts	G	P	S	Approx. Weight						
4-Bolt Square																					
7	1 15/16	ZFS9115	5 3/4	5/8	5/16	5/16	5 5/8	16.00	ZF9115	5	5/8	1 1/64	19/32	5	12.90	4 1/2	3 3/16	5 7/8	3 5/32	1 1/16	2 31/32
	2	ZFS9200					15.00	ZF9200						12.70							
	45.00	ZFS9045MM	146.05	16.00	7.94	7.94	142.880	7.20	ZF9045MM	127.00	16.00	4.34	15.08	127.000	6.10						
	50.00	ZFS9050MM						7.00	ZF9050MM						5.80						
8	2 3/16	ZFS9203	6	5/8	5/16	1 1/32	6	19.00	ZF9203	5 1/2	5/8	1/4	23/32	5 7/16	16.40	5 1/32	3 9/16	6 7/16	3 11/32	3/4	3 3/8
	55.00	ZFS9055MM	152.40	16.00	7.94	8.73	152.400	8.60	ZF9055MM	139.70	16.00	6.35	18.26	138.110	7.50	127.80	90.49	163.51	84.93	19.05	85.73
9	2 7/16	ZFS9207	7 1/8	3/4	1/4	15/32	7 1/8	31.00	ZF9207	6 1/2	3/4	15/64	5/8	6 5/16	26.60	6 1/64	4 1/4	7 3/4	3 3/4	7/8	3 5/8
	2 1/2	ZFS9208						26.40	ZF9208						26.40						
10	2 1 1/16	ZFS9211						45.30	ZF9211						37.60	6 23/32	4 3/4	8 7/16	4 1/4	1	4 13/32
	2 5/16	ZFS9215	8	3/4	3/8	7/16	8	44.00	ZF9215	7 3/8	3/4	1/4	13/16	7 3/8	37.00						
	3	ZFS9300						43.00	ZF9300						36.60						
	75.00	ZFS9075MM	203.20	19.00	9.53	11.11	203.200	20.00	ZF9075MM	187.33	19.00	6.35	20.64	187.330	16.80						
11	3 3/16	ZFS9303	9 1/2	1	3/8	9/16	9 1/2	79.00	ZF9303	8 7/8	1	1/4	15/16	8 7/8	66.00	8 5/16	5 7/8	10 9/16	5	1 1/8	5 3/16
	3 7/16	ZFS9307						76.00	ZF9307						65.00						
	80.00	ZFS9080MM	241.30	25.00	9.53	14.29	241.300	36.00	ZF9080MM	225.43	25.00	6.35	23.81	225.430	30.00	211.14	149.23	268.29	127.00	28.58	131.76
6-Bolt Round																					
12	3 1 1/16	ZFS9311Y						126.00	ZF9311Y						96.00	6 7/16	6 7/16	15 1/8	5 17/32	1 1/4	5 23/32
	3 15/16	ZFS9315Y	11 5/8	1	3/16	23/32	11 5/8	124.00	ZF9315Y	9 1/2	1	1/8	1 1/32	10 3/8	94.00						
	4	ZFS9400Y						123.00	ZF9400Y						93.00						
	100.00	ZFS9100MM	295.28	25.00	4.76	18.25	295.280	56.00	ZF9100MM	241.30	25.00	3.18	26.19	263.530	43.00	163.51	163.51	384.18	140.49	31.75	145.26
13	4 3/16	ZFS9403						184.00	ZF9403						159.00	7	7	16 1/2	6 3/4	1 1/2	6 1/8
	4 7/16	ZFS9407	12 9/16	1	5/16	5/8	12 9/16	182.00	ZF9407	11 3/16	1 1/8	9/32	1 1/8	11 3/16	157.00						

Additional Notes

- Please call 1-866-REXNORD for availability
- Lubrication fitting tap size: for size code 7 thru 11, 1/8" PT; for all other size codes, 1/4" PT
- Machined pilot available, add suffix S
- Expansion - size code 7 thru 8 is 3/8", size code 9 thru 11 is 1/2" & size code 12 thru 13 is 3/4"
- Seals - To specify G, K or M seal, replace "Z" in part number with "G", "K" or "M"
- "K" seals only available in size codes 7 thru 11

Auxiliary end caps - available in all size codes except size code 12 ZFS bearings
 For the Selection Guide, Load Ratings and Speed Limits, see the Spherical Roller Bearings Engineering section on pages 15 - 27.

Note: Dimensions subject to change. Certified dimensions of ordered material furnished on request.

ZEF2000

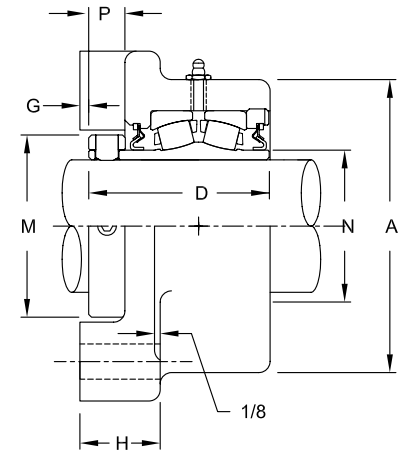
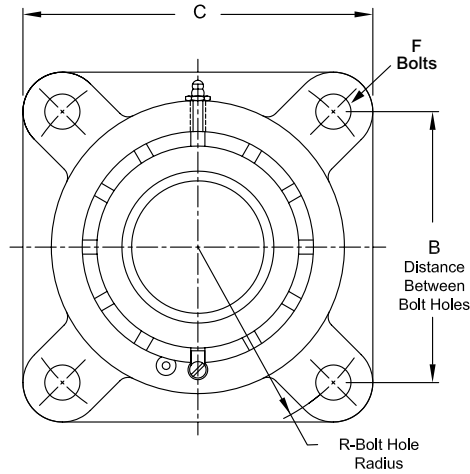
Interchange: EF4BS2, F4BE, FYE, USFBE5000, RFBA, QAF, E4BFTRB



Photo Shows a 4-Bolt Spherical Roller Bearing Flanged Unit

Product Features

- Corrosion-resistant powder coating
- Cast iron housing
- Misalignment capabilities - total of 4°
- Broad range of sealing options
- Factory set clearance & lubrication
- Precision ground & superfinished raceways
- Hardened spring locking collar
- Field interchangeable seals
- See Features and Benefits for additional info on pages 10 - 13.



Bearing Dimensions

Size Code	Shaft Diameter	Part Number	B Distance Between Bolt Holes	R Bolt Circle Radius	A	C	D	F Bolts	G	H	M	N	P	Approx. Weight
4	1 7/16	ZEF2107	3 1/2	2 15/32	3 11/16	4 5/8	2 7/8	1/2	1/16	1 3/8	2 5/16	1 3/4	11/16	7.20
	1 1/2	ZEF2108	4 1/8	2 59/64	4 1/4	5 3/8								10.00
	35.00	ZEF2035MM	88.90	62.69	93.66	117.48	73.02	13.00	1.59	34.93	58.74	44.450	17.46	3.20
5	1 11/16	ZEF2111	4 1/8	2 59/64	4 1/4	5 3/8	3 1/8	1/2	1/8	1 7/16	2 19/32	2 1/32	11/16	10.00
	1 3/4	ZEF2112	4 3/8	3 3/32	4 1/2	5 5/8								11.20
	40.00	ZEF2040MM	104.78	74.24	107.95	136.53	79.38	13.00	3.18	36.51	65.88	51.590	17.46	4.50
45.00	ZEF2045MM	111.13	78.59	114.30	142.88	5.00								
6	1 15/16	ZEF2115	4 3/8	3 3/32	4 1/2	5 5/8	3 1/8	1/2	1/8	1 1/2	2 7/8	2 5/16	11/16	11.00
	2	ZEF2200												10.80
	50.00	ZEF2050MM	111.13	78.59	114.30	142.88	79.38	13.00	3.18	38.10	73.03	58.740	17.46	4.90
7	2 3/16	ZEF2203	4 7/8	3 29/64	5	6 1/4	3 5/16	5/8	1/8	1 1/2	3 1/4	2 5/8	13/16	14.10
	55.00	ZEF2055MM	123.83	87.71	127.00	158.75	84.14	16.00	3.18	38.10	82.55	66.680	20.64	6.40
8	2 7/16	ZEF2207	5 3/8	3 51/64	5 1/2	6 7/8	3 1/2	5/8	3/16	1 11/16	3 9/16	2 29/32	7/8	17.30
	2 1/2	ZEF2208												17.10
	60.00	ZEF2060MM	135.53	96.42	139.70	174.63	88.90	16.00	4.76	42.86	90.49	73.810	22.23	7.80
	65.00	ZEF2065MM												7.50
9	2 11/16	ZEF2211	6	4 1/4	6 1/2	7 3/4	4	3/4	3/16	1 13/16	4 1/16	3 3/8	7/8	28.40
	2 3/4	ZEF2212												28.20
	2 15/16	ZEF2215												27.20
	3	ZEF2300												26.90
	70.00	ZEF2070MM	152.40	107.95	165.10	196.85	101.60	19.00	4.76	46.04	103.19	85.730	22.23	12.80
75.00	ZEF2075MM	12.40												
10	3 3/16	ZEF2303	7	4 61/64	7 3/8	9 1/4	4 3/8	3/4	1/4	1 15/16	4 29/32	3 31/32	15/16	42.00
	3 7/16	ZEF2307												40.50
	3 1/2	ZEF2308												40.00
	80.00	ZEF2080MM												177.80
	85.00	ZEF2085MM	18.60											
90.00	ZEF2090MM	18.10												
11	3 11/16	ZEF2311	7 3/4	5 31/64	8 7/8	10 1/4	5 1/16	7/8	1/4	2 3/16	5 5/8	4 9/16	1 1/32	64.00
	3 15/16	ZEF2315												69.00
	4	ZEF2400												68.00
	100.00	ZEF2100MM	196.85	139.29	225.43	260.35	128.59	22.00	6.35	55.56	142.88	115.890	26.19	31.30

Additional Notes

- Please call 1-866-REXNORD for availability
- Metric bore sizes available, see Rex Interchangeability guide
- Lubrication fitting tap size, 1/8" PT
- Bore size = nominal shaft size +.001 in/-.000 in (+0.03 mm/-0.00 mm)
- Seals - To specify G, K or M seal, replace "Z" in part number with "G", "K" or "M"
- Auxiliary end caps - available in all size codes

For the Selection Guide, Load Ratings and Speed Limits, see the Spherical Roller Bearings Engineering section on pages 15 - 27.
 Note: Dimensions subject to change. Certified dimensions of ordered material furnished on request.

ZEF3000

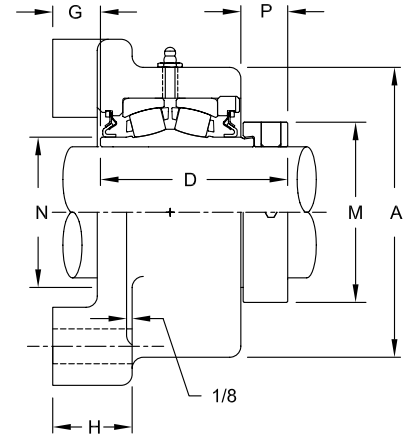
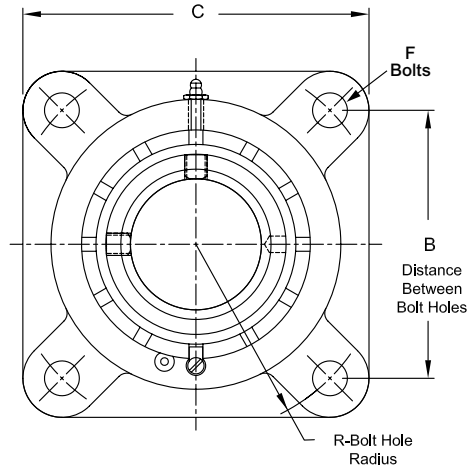
Interchange: QMF



Photo Shows a 4-Bolt Spherical Roller Bearing Flanged Unit

Product Features

- Corrosion-resistant powder coating
 - Cast iron housing
 - Misalignment capabilities - total of 4°
 - Broad range of sealing options
 - Factory set clearance & lubrication
 - Precision ground & superfinished raceways
 - Hardened eccentric locking collar
 - Field interchangeable seals
- See Features and Benefits for additional info on pages 10 - 13.

**Bearing Dimensions**

Size Code	Shaft Diameter	Part Number	B Distance Between Bolt Holes	R Bolt Circle Radius	A	C	D	F Bolts	G	H	M	N	P	Approx. Weight
4	1 ⁷ / ₁₆	ZEF3107	3 ¹ / ₂	2 ¹⁵ / ₃₂	3 ¹¹ / ₁₆	4 ⁵ / ₈	2 ⁵⁹ / ₆₄	1/2	3/4	1 ³ / ₈	2 ⁵ / ₁₆	1 ³ / ₄	2 ⁵ / ₃₂	7.40
5	1 ¹¹ / ₁₆	ZEF3111	4 ¹ / ₈	2 ⁵⁹ / ₆₄	4 ¹ / ₄	5 ³ / ₈	3 ³ / ₁₆	1/2	13/16	1 ⁷ / ₁₆	2 ⁵ / ₈	2 ¹ / ₃₂	3/4	10.30
6	1 ¹⁵ / ₁₆	ZEF3115	4 ³ / ₈	3 ³ / ₃₂	4 ¹ / ₂	5 ³ / ₈	3 ⁹ / ₃₂	1/2	7/8	1 ¹ / ₂	2 ³ / ₄	2 ⁵ / ₁₆	2 ⁷ / ₃₂	11.20
7	2 ³ / ₁₆	ZEF3203	4 ⁷ / ₈	3 ²⁹ / ₆₄	5	6 ¹ / ₄	3 ¹ / ₂	5/8	15/16	1 ¹ / ₂	3 ¹ / ₄	2 ⁵ / ₈	3 ¹ / ₃₂	11.00
8	2 ⁷ / ₁₆	ZEF3207	5 ³ / ₈	3 ⁵¹ / ₆₄	5 ¹ / ₂	6 ⁷ / ₈	3 ²¹ / ₃₂	5/8	1 ¹ / ₁₆	1 ¹¹ / ₁₆	3 ⁹ / ₁₆	2 ²⁹ / ₃₂	1 ¹ / ₆₄	17.50
	2 ¹ / ₂	ZEF3208												16.50
9	2 ¹¹ / ₁₆	ZEF3211	6	4 ¹ / ₄	6 ¹ / ₂	7 ³ / ₄	4 ¹³ / ₆₄	3/4	1 ¹ / ₁₆	1 ¹³ / ₁₆	4 ¹ / ₁₆	3 ³ / ₈	1 ¹ / ₆₄	28.60
	2 ¹⁵ / ₁₆	ZEF3215												27.60
10	3 ⁷ / ₁₆	ZEF3307	7	4 ⁶¹ / ₆₄	7 ³ / ₈	9 ¹ / ₄	4 ³⁷ / ₆₄	3/4	1 ¹¹ / ₆₄	1 ¹⁵ / ₁₆	4 ¹⁵ / ₁₆	3 ³¹ / ₃₂	1 ⁹ / ₆₄	41.10
	3 ¹ / ₂	ZEF3308												40.20
11	3 ¹⁵ / ₁₆	ZEF3315	7 ³ / ₄	5 ³¹ / ₆₄	8 ⁷ / ₈	10 ¹ / ₄	5 ³ / ₁₆	7/8	1 ⁵ / ₁₆	2 ³ / ₁₆	5 ⁵ / ₈	4 ⁹ / ₁₆	1 ¹ / ₁₆	62.70

Additional Notes

- Please call 1-866-REXNORD for availability
- Lubrication fitting tap size, 1/8" PT
- Bore size = nominal shaft size +.001 in/-.000 in (+0.03 mm/-0.00 mm)
- Seals - To specify G, K or M seal, replace "Z" in part number with "G", "K" or "M"
- Auxiliary end caps - available in all size codes

For the Selection Guide, Load Ratings and Speed Limits, see the Spherical Roller Bearings Engineering section on pages 15 - 27.

Note: Dimensions subject to change. Certified dimensions of ordered material furnished on request.

ZEF5000

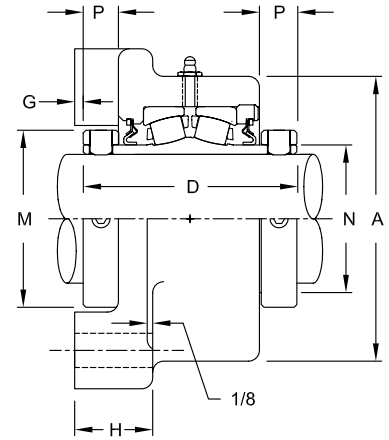
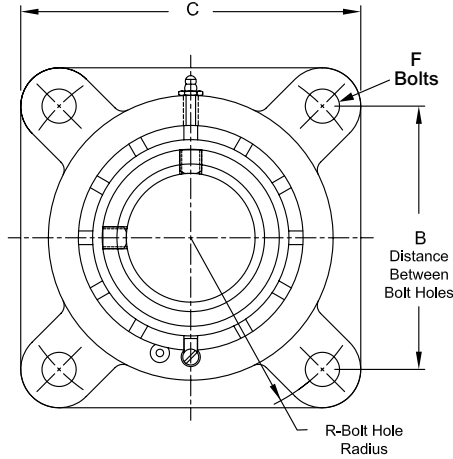
Interchange: RFB, QAAF



Photo Shows a 4-Bolt Spherical Roller Bearing Flanged Unit

Product Features

- Corrosion-resistant powder coating
- Cast iron housing
- Misalignment capabilities - total of 4°
- Broad range of sealing options
- Factory set clearance & lubrication
- Precision ground & superfinished raceways
- Two hardened spring locking collars
- Field interchangeable seals
- See Features and Benefits for additional info on pages 10 - 13.



Bearing Dimensions

Size Code	Shaft Diameter	Part Number	B Distance Between Bolt Holes	R Bolt Circle Radius	A	C	D	F Bolts	G	H	M	N	P	Approx. Weight											
4	1 7/16	ZEF5107	3 1/2	2 15/32	3 11/16	4 5/8	3 9/16	1/2	1/16	1 3/8	2 5/16	1 3/4	11/16	7.70											
	35.00	ZEF5035MM	88.90	62.69	93.66	117.48	90.49	13.00	1.59	34.93	58.74	44.450	17.46	3.50											
5	1 1/2	ZEF5108	4 1/8	2 59/64	4 1/4	5 3/8	3 13/16	1/2	1/8	1 7/16	2 19/32	2 1/32	11/16	11.00											
	1 11/16	ZEF5111												10.60											
	40.00	ZEF5040MM												5.00											
	45.00	ZEF5045MM	104.78	74.24	107.95	136.53	96.84	13.00	3.18	36.51	65.88	51.590	17.46	4.80											
6	1 15/16	ZEF5115	4 3/8	3 3/32	4 1/2	5 5/8	3 13/16	1/2	1/8	1 1/2	2 7/8	2 5/16	11/16	11.70											
	50.00	ZEF5050MM	111.13	78.59	114.30	142.88	96.84	13.00	3.18	38.10	73.03	58.740	17.46	5.30											
7	2	ZEF5200	4 7/8	3 29/64	5	6 1/4	4 1/8	5/8	1/8	1 1/2	3 1/4	2 5/8	13/16	15.70											
	2 3/16	ZEF5203												15.10											
	55.00	ZEF5055MM												123.83	87.71	127.00	158.75	104.78	16.00	3.18	38.10	82.60	66.680	20.64	6.80
8	2 7/16	ZEF5207	5 3/8	3 51/64	5 1/2	6 7/8	4 3/8	5/8	3/16	1 11/16	3 9/16	2 29/32	7/8	18.30											
	60.00	ZEF5060MM	135.53	96.42	139.70	174.63	111.13	16.00	4.76	42.86	90.50	73.810	22.23	8.30											
	65.00	ZEF5065MM												8.70											
9	2 1/2	ZEF5208	6	4 1/4	6 1/2	7 3/4	4 7/8	3/4	3/16	1 13/16	4 1/16	3 3/8	7/8	31.10											
	2 11/16	ZEF5211												30.10											
	2 15/16	ZEF5215												29.60											
	70.00	ZEF5070MM												152.40	107.95	165.10	196.85	123.83	19.00	4.76	46.04	103.20	85.730	22.23	13.70
	75.00	ZEF5075MM	13.40																						
10	3 3/16	ZEF5303	7	4 61/64	7 3/8	9 1/4	5 5/16	3/4	1/4	1 15/16	4 29/32	3 31/32	15/16	44.60											
	3 7/16	ZEF5307												42.70											
	80.00	ZEF5080MM												177.80	125.81	187.33	234.95	134.94	19.00	6.35	49.20	124.62	100.790	23.81	20.20
	85.00	ZEF5085MM																							19.80
90.00	ZEF5090MM	19.40																							
11	3 11/16	ZEF5311	7 3/4	5 31/64	8 7/8	10 1/4	6 1/8	7/8	1/4	2 3/16	5 5/8	4 9/16	1 1/32	66.50											
	3 15/16	ZEF5315												65.50											
	4	ZEF5400												64.50											
	100.00	ZEF5100MM												196.85	139.29	225.43	260.35	155.58	22.00	6.35	55.56	142.90	115.890	26.19	29.70

Additional Notes

- Please call 1-866-REXNORD for availability
- Metric bore sizes available, see Rex Interchangeability guide
- Lubrication fitting tap size, 1/8" PT
- Bore size = nominal shaft size +.001 in/-.000 in (+0.03 mm/-0.00 mm)
- Seals - To specify G, K or M seal, replace "Z" in part number with "G", "K" or "M"
- Auxiliary end caps - available in all size codes

For the Selection Guide, Load Ratings and Speed Limits, see the Spherical Roller Bearings Engineering section on pages 15 - 27.

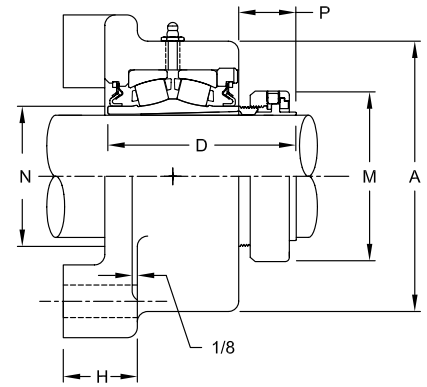
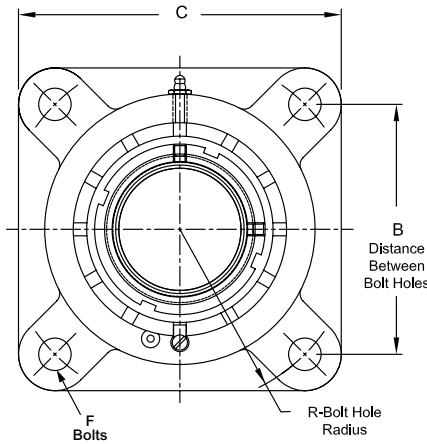
Note: Dimensions subject to change. Certified dimensions of ordered material furnished on request.

ZEF6000

Interchange: EF4BIP, USFBE5000A, QVF, QVVF, DVF



Photo Shows a 4-Bolt Spherical Roller Bearing Flanged Unit



Product Features

- Spyglass Optical Strain Sensor (OSS) Technology
- Positive locking system
- Tapered adapter sleeve
- Corrosion-resistant powder coating
- Cast iron housing
- Misalignment capabilities - total of 4°
- Broad range of sealing options
- Factory set clearance & lubrication
- Precision ground & superfinished raceways
- See Features and Benefits for additional info on pages 10 - 13.

Bearing Dimensions

Size Code	Shaft Diameter	Part Number	B Distance Between Bolt Holes	R Bolt Circle Radius	A	C	D	F Bolts	H	M	N	P	Approx. Weight										
4-Bolt																							
4	1 7/16	ZEF6107	3 1/2	2 15/32	3 11/16	4 5/8	3 21/64	1/2	1 3/8	2 25/64	1 3/4	1 9/64	7.20										
5	1 11/16	ZEF6111	4 1/8	2 59/64	4 1/4	5 3/8	3 47/64		1 7/16	2 41/64	2 1/32	1 9/32	10.00										
6	1 15/16	ZEF6115	4 3/8	3 3/32	4 1/2	5 5/8	3 41/64		1 1/2	2 55/64	2 5/16	1 1/8	11.70										
	45.00	ZEF6045MM	111.13	78.59	114.30	142.88	92.47	13.00	38.10	72.63	58.740	28.58	4.80										
7	2 3/16	ZEF6203	4 7/8	3 29/64	5	6 1/4	3 11/16	5/8	1 1/2	3 15/64	2 5/8	1 5/32	15.70										
	55.00	ZEF6055MM	123.83	87.71	127.00	158.75	93.66	16.00	38.10	82.15	66.680	29.37	6.80										
8	2 3/8	ZEF6206	5 3/8	3 51/64	5 1/2	6 7/8	4 1/16	5/8	1 11/16	3 19/32	2 29/32	1 27/64	18.90										
	2 7/16	ZEF6207											18.30										
	60.00	ZEF6060MM											135.53	96.42	139.70	174.63	103.19	16.00	42.86	91.28	73.810	36.12	8.30
9	2 11/16	ZEF6211	6	4 1/4	6 1/2	7 3/4	4 17/32	3/4	1 13/16	4 3/32	3 3/8	1 25/64	31.10										
	2 3/4	ZEF6212											30.10										
	2 15/16	ZEF6215											29.60										
	70.00	ZEF6070MM											152.40	107.95	165.10	196.85	115.09	19.00	46.04	103.98	85.730	35.32	13.70
	75.00	ZEF6075MM											13.40										
10	3 3/16	ZEF6303	7	4 61/64	7 3/8	9 1/4	5 1/32	3/4	1 15/16	4 61/64	3 31/32	1 19/32	44.60										
	3 7/16	ZEF6307											42.70										
	80.00	ZEF6080MM											177.80	125.81	187.33	234.95	127.79	19.00	49.20	125.81	100.790	40.48	20.20
	85.00	ZEF6085MM																					19.80
11	3 11/16	ZEF6311	7 3/4	5 31/64	8 7/8	10 1/4	5 25/32	7/8	2 3/16	5 43/64	4 9/16	1 47/64	66.50										
	3 15/16	ZEF6315											65.50										
	90.00	ZEF6090MM											196.85	139.29	225.43	260.35	146.84	22.00	55.56	144.07	115.890	44.05	29.70
	100.00	ZEF6100MM																					

Additional Notes

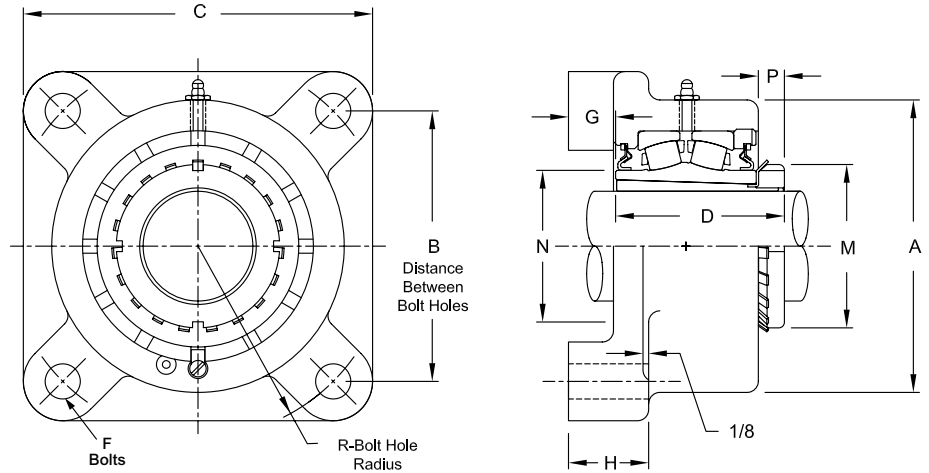
- Please call 1-866-REXNORD for availability
- Lubrication fitting tap size, 1/8" PT
- Seals - To specify G, K or M seal, replace "Z" in part number with "G", "K" or "M"
- Auxiliary end caps - available in all size codes
- For the Selection Guide, Load Ratings and Speed Limits, see the Spherical Roller Bearings Engineering section on pages 15 - 27.
- Note: Dimensions subject to change. Certified dimensions of ordered material furnished on request.



Photo Shows a 4-Bolt Spherical Roller Bearing Flanged Unit

Product Features

- Corrosion-resistant powder coating
- Cast iron housing
- Misalignment capabilities - total of 4°
- Broad range of sealing options
- Factory set clearance & lubrication
- Precision ground & superfinished raceways
- Enhanced life mounting style
- Field interchangeable seals
- See Features and Benefits for additional info on pages 10 - 13.



Bearing Dimensions

Size Code	Shaft Diameter	Part Number	B Distance Between Bolt Holes	R Bolt Circle Radius	A	C	D	F Bolts	G	H	M	N	P	Approx. Weight
7	1 15/16	ZEF9115	4 7/8	3 29/64	5	6 1/4	3 5/32	5/8	15/16	1 1/2	2 31/32	2 5/8	19/32	14.30
	2	ZEF9200												14.20
	45.00	ZEF9045MM	123.83	87.71	127.00	158.75	80.17	16.00	23.81	38.10	75.40	66.680	15.08	6.50
	50.00	ZEF9050MM												
8	2 3/16	ZEF9203	5 3/8	3 51/64	5 1/2	6 7/8	3 11/32	5/8	1 1/16	1 11/16	3 3/8	2 29/32	23/32	17.60
	55.00	ZEF9055MM	135.53	96.42	139.70	174.63	84.93	16.00	26.99	42.86	85.73	73.810	18.26	8.00
9	2 7/16	ZEF9207	6	4 1/4	6 1/2	7 3/4	3 3/4	3/4	1 1/16	1 13/16	3 5/8	3 3/8	5/8	27.70
	2 1/2	ZEF9208												27.40
10	2 11/16	ZEF9211	7	4 61/64	7 3/8	9 1/4	4 1/4	3/4	1 11/64	1 15/16	4 13/32	3 31/32	13/16	42.30
	2 15/16	ZEF9215												41.10
	3	ZEF9300												40.40
	75.00	ZEF9075MM	177.80	125.81	187.33	234.95	107.95	19.00	29.77	49.20	111.92	100.790	20.64	18.60
11	3 3/16	ZEF9303	7 3/4	5 31/64	8 7/8	10 1/4	5	7/8	1 5/16	2 3/16	5 3/16	4 9/16	15/16	67.00
	3 7/16	ZEF9307												65.00
	80.00	ZEF9080MM	196.85	139.29	225.43	260.35	127.00	22.00	33.34	55.56	131.76	115.890	23.81	30.40

Additional Notes

- Please call 1-866-REXNORD for availability
- Lubrication fitting tap size, 1/8" PT
- Seals - To specify G, K or M seal, replace "Z" in part number with "G", "K" or "M"
- Auxiliary end caps - available in all size codes
- For the Selection Guide, Load Ratings and Speed Limits, see the Spherical Roller Bearings Engineering section on pages 15 - 27.
- Note: Dimensions subject to change. Certified dimensions of ordered material furnished on request.

ZBR2000

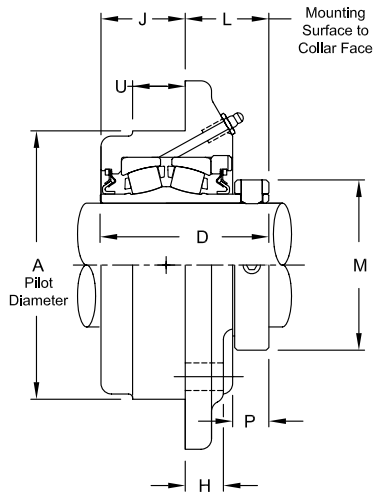
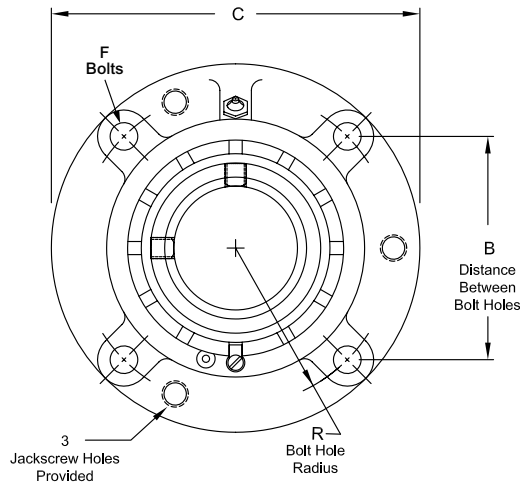
Interchange: FCS2, FCE, FYRP, USFC5000, USFCE5000, RFPA, QACW, EPFTRB



Photo Shows a 4-Bolt Spherical Roller Bearing Flanged Cartridge Unit

Product Features

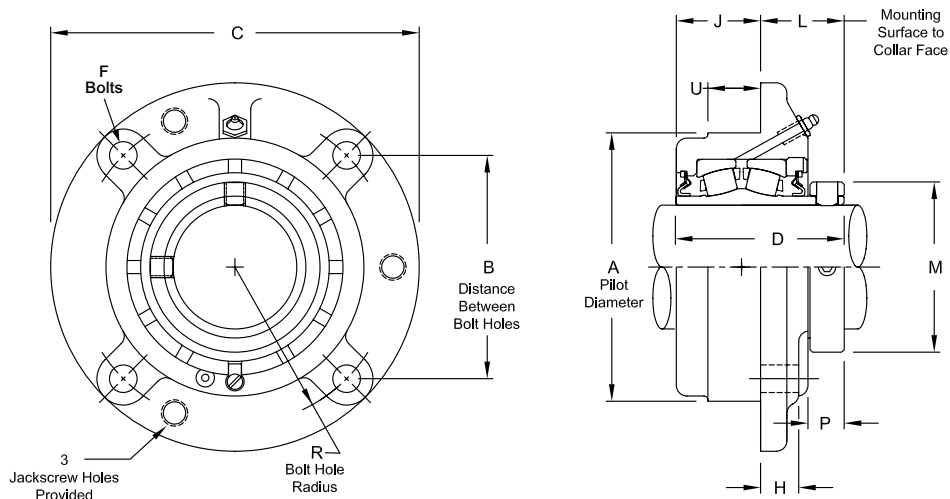
- Corrosion-resistant powder coating
- Cast iron housing
- Misalignment capabilities - total of 4°
- Broad range of sealing options
- Factory set clearance & lubrication
- Precision ground & superfinished raceways
- Hardened spring locking collar
- Field interchangeable seals
- See Features and Benefits for additional info on pages 10 - 13.



Bearing Dimensions

Size Code	Shaft Diameter	Part Number	A Pilot Diameter	B Distance Between Bolt Holes	L Mounting Surface to Collar Face	R Bolt Circle Radius	C	D	F Bolts	H	J	M	P	U	Approx. Weight
4-Bolt															
2	3/4	ZBR2012	3.000	2 9/16	1 5/16	1 13/16	4 3/8	2 9/16	5/16	7/16	1 1/4	1 3/4	9/16	5/8	3.70
	15/16	ZBR2015													3.60
	1	ZBR2100													3.50
	25.00	ZBR2025MM	76.200	65.09	33.34	46.04	111.13	65.09	8.00	11.11	31.75	44.45	14.29	15.88	1.60
3	1 1/8	ZBR2102	3.375	2 59/64	1 5/16	2 1/16	5	2 11/16	3/8	7/16	1 3/8	1 31/32	9/16	3/4	4.90
	1 3/16	ZBR2103													4.80
	1 1/4	ZBR2104													4.60
	30.00	ZBR2030MM	85.725	74.19	33.34	52.39	127.00	68.26	9.00	11.11	34.93	50.00	14.29	19.05	2.20
4	1 7/16	ZBR2107	3.625	3 3/32	1 1/2	2 3/16	5 1/4	2 7/8	3/8	1/2	1 3/8	2 5/16	11/16	3/4	5.40
	1 1/2	ZBR2108													5.20
	35.00	ZBR2035MM	92.075	53.19	38.10	55.56	133.35	73.02	9.00	12.70	34.93	58.74	17.46	19.05	2.50
5	1 11/16	ZBR2111	4.250	3 5/8	1 19/32	2 9/16	6 1/8	3 1/8	7/16	1/2	1 17/32	2 19/32	11/16	7/8	8.40
	1 3/4	ZBR2112													8.10
	40.00	ZBR2040MM	107.950	92.08	40.49	65.09	155.58	79.38	11.00	12.70	38.89	65.88	17.46	22.23	3.90
	45.00	ZBR2045MM													3.70
6	1 15/16	ZBR2115	4.500	3 51/64	1 9/16	2 11/16	6 3/8	3 1/8	7/16	9/16	1 9/16	2 7/8	11/16	7/8	8.80
	2	ZBR2200													8.70
	50.00	ZBR2050MM	114.300	96.44	39.69	68.26	161.93	79.38	11.00	14.29	39.69	73.03	17.46	22.23	4.00
7	2 3/16	ZBR2203	5.000	4 1/4	1 3/4	3	7 1/8	3 5/16	1/2	9/16	1 9/16	3 1/4	13/16	1	13.80
	2 1/4	ZBR2204													13.70
	55.00	ZBR2055MM	127.000	107.95	44.45	76.20	180.98	84.14	13.00	14.29	39.69	82.55	19.84	25.40	6.30
8	2 3/8	ZBR2206	5.500	4 19/32	1 13/16	3 1/4	7 5/8	3 1/2	1/2	5/8	1 11/16	3 9/16	7/8	1	14.90
	2 7/16	ZBR2207													14.80
	2 1/2	ZBR2208													14.40
	60.00	ZBR2060MM	139.700	116.66	46.04	82.55	193.68	88.90	13.00	15.88	42.86	90.49	22.23	25.40	6.80
	65.00	ZBR2065MM													6.50
9	2 11/16	ZBR2211	6.375	5 19/64	2	3 3/4	8 3/4	4	5/8	3/4	2	4 1/16	7/8	1 1/4	23.40
	2 3/4	ZBR2212													23.00
	2 15/16	ZBR2215													22.30
	3	ZBR2300													21.80
	70.00	ZBR2070MM	161.925	134.54	50.80	95.25	222.25	101.60	16.00	19.05	50.80	103.19	22.23	31.75	10.50
	75.00	ZBR2075MM													10.10
10	3 3/16	ZBR2303	7.375	6 3/32	2 3/8	4 5/16	10 1/4	4 3/8	3/4	15/16	2	4 29/32	15/16	1 1/4	35.50
	3 7/16	ZBR2307													34.00

Continued...



Continued...

Bearing Dimensions

Size Code	Shaft Diameter	Part Number	A Pilot Diameter	B Distance Between Bolt Holes	L Mounting Surface to Collar Face	R Bolt Circle Radius	C	D	F Bolts	H	J	M	P	U	Approx. Weight
4-Bolt (continued)															
10	3 1/2	ZBR2308	7.375	6 3/32	2 3/8	4 5/16	10 1/4	4 3/8	3/4	15/16	2	4 29/32	15/16	1 1/4	33.50
	80.00	ZBR2080MM													16.10
	85.00	ZBR2085MM	187.325	154.79	60.33	109.54	260.35	111.13	19.00	23.81	50.80	124.62	23.81	31.75	15.70
	90.00	ZBR2090MM													15.20
11	3 11/16	ZBR2311													52.00
	3 15/16	ZBR2315	8.125	6 5/8	2 11/16	4 11/16	10 7/8	5 1/16	3/4	1 1/8	2 1/2	5 5/8	1 1/32	1 1/2	49.00
	4	ZBR2400													48.50
	100.00	ZBR2100MM	206.375	168.28	68.26	119.06	276.23	128.59	19.00	28.58	63.50	142.88	26.19	38.10	22.20

Additional Notes

- Please call 1-866-REXNORD for availability
- Metric bore sizes available, see Rex Interchangeability guide
- Lubrication fitting tap size, 1/8" PT
- Bore size = nominal shaft size +.001 in/-.000 in (+0.03 mm/-0.00 mm)
- Pilot Diameter tolerance, +.000 in/-.002 in (+0.00 mm/-0.05 mm)
- Bore tolerance for mounting, +.002 in/-.000 in (+0.05 mm/-0.00 mm)
- Seals - To specify G, K or M seal, replace "Z" in part number with "G", "K" or "M"

- Auxiliary end caps - available in all size codes except for size codes 2 & 3
- "G" seals available in size codes 3 thru 11
- For the Selection Guide, Load Ratings and Speed Limits, see the Spherical Roller Bearings Engineering section on pages 15 - 27.
- Note: Dimensions subject to change. Certified dimensions of ordered material furnished on request.

ZBR3000

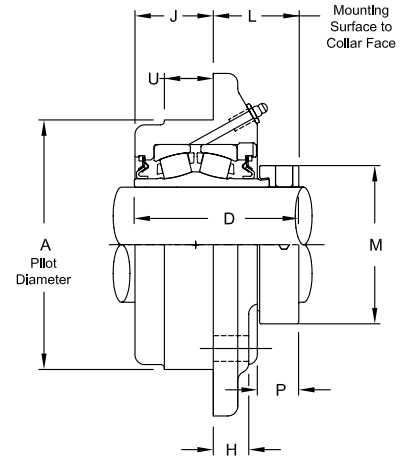
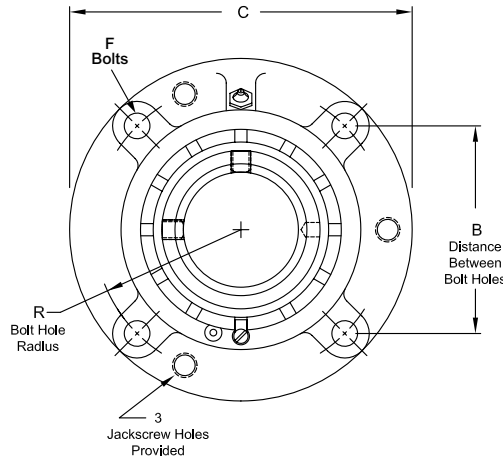
Interchange: QMCW



Photo Shows a 4-Bolt Spherical Roller Bearing Flanged Cartridge Unit

Product Features

- Corrosion-resistant powder coating
- Cast iron housing
- Misalignment capabilities - total of 4°
- Broad range of sealing options
- Factory set clearance & lubrication
- Precision ground & superfinished raceways
- Eccentric locking collar
- Field interchangeable seals
- See Features and Benefits for additional info on pages 10 - 13.



Bearing Dimensions

Size Code	Shaft Diameter	Part Number	A Pilot Diameter	B Distance Between Bolt Holes	L Mounting Surface to Collar Face	R Bolt Circle Radius	C	D	F Bolts	H	J	M	P	U	Approx. Weight
4-Bolt															
4	1 7/16	ZBR3107	3.625	3 3/32	1 1/2	2 3/16	5 1/4	2 59/64	3/8	1/2	1 3/8	2 5/16	25/32	3/4	5.60
5	1 11/16	ZBR3111	4.250	3 9/8	1 19/32	2 9/16	6 1/8	3 3/16	7/16	1/2	1 17/32	2 5/8	3/4	7/8	8.60
6	1 15/16	ZBR3115	4.500	3 51/64	1 23/32	2 11/16	6 3/8	3 9/32	7/16	9/16	1 9/16	2 15/16	27/32	7/8	9.00
7	2 3/16	ZBR3203	5.000	4 1/4	1 15/16	3	7 1/8	3 1/2	1/2	9/16	1 9/16	3 1/4	31/32	1	14.10
8	2 7/16	ZBR3207	5.500	4 19/32	1 31/32	3 1/4	7 5/8	3 21/32	1/2	5/8	1 11/16	3 9/16	1 1/64	1	15.00
	2 1/2	ZBR3208													14.60
9	2 11/16	ZBR3211	6.375	5 19/64	2 13/64	3 3/4	8 3/4	4 13/64	5/8	3/4	2	4 1/16	1 1/64	1 1/4	23.80
	2 15/16	ZBR3215													22.70
10	3 7/16	ZBR3307	7.375	6 3/32	2 37/64	4 5/16	10 1/4	4 37/64	3/4	15/16	2	4 15/16	1 9/64	1 1/4	34.40
	3 1/2	ZBR3308													33.90
11	3 15/16	ZBR3315	8.125	6 5/8	2 11/16	4 11/16	10 7/8	5 3/16	3/4	1 1/8	2 1/2	5 5/8	1 1/16	1 1/2	49.00

Additional Notes

- Please call 1-866-REXNORD for availability
- Lubrication fitting tap size, 1/8" PT
- Bore size = nominal shaft size +.001 in/-.000 in (+0.03 mm/-0.00 mm)
- Pilot Diameter tolerance, +.000 in/-.002 in (+0.00 mm/-0.05 mm)
- Bore tolerance for mounting, +.002 in/-.000 in (+0.05 mm/-0.00 mm)
- Seals - To specify G, K or M seal, replace "Z" in part number with "G", "K" or "M"
- Auxiliary end caps - available in all size codes

For the Selection Guide, Load Ratings and Speed Limits, see the Spherical Roller Bearings Engineering section on pages 15 - 27.

Note: Dimensions subject to change. Certified dimensions of ordered material furnished on request.

ZBR5000

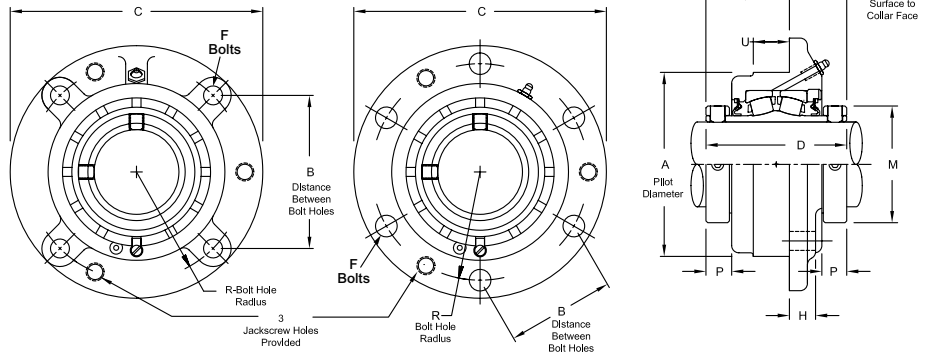
Interchange: RFP, QAACW



Photo Shows a 4-Bolt Spherical Roller Bearing Flanged Cartridge Unit

Product Features

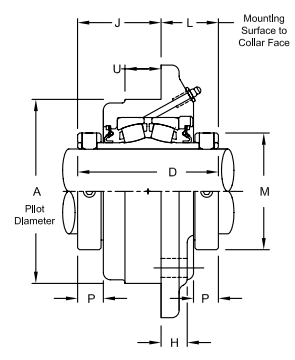
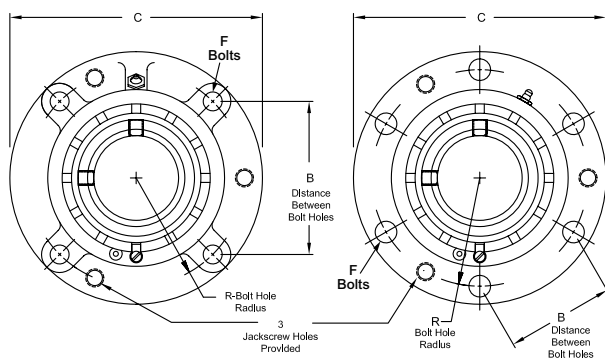
- Corrosion-resistant powder coating
- Cast iron housing
- Misalignment capabilities - total of 4°
- Broad range of sealing options
- Factory set clearance & lubrication
- Precision ground & superfinished raceways
- Two hardened spring locking collars
- Field interchangeable seals
- See Features and Benefits for additional info on pages 10 - 13.



Bearing Dimensions

Size Code	Shaft Diameter	Part Number	A Pilot Diameter	B Distance Between Bolt Holes	L Mounting Surface to Collar Face	R Bolt Circle Radius	C	D	F Bolts	H	J	M	P	U	Approx. Weight												
4-Bolt																											
4	1 7/16	ZBR5107	3.625	53.19	1 1/2	2 3/16	5 1/4	3 9/16	3/8	1/2	2 1/16	2 5/16	11/16	3/4	5.90												
	35.00	ZBR5035MM	92.075	53.19	38.10	55.56	133.35	90.49	9.00	12.70	52.39	58.74	17.46	19.05	2.70												
5	1 1/2	ZBR5108	4.250	3 5/8	1 19/32	2 9/16	6 1/8	3 13/16	7/16	1/2	2 7/32	2 19/32	11/16	7/8	9.10												
	1 11/16	ZBR5111													8.70												
	40.00	ZBR5040MM	107.950	92.08	40.49	65.09	155.58	96.84	11.00	12.70	56.34	65.88	17.46	22.23	4.10												
	45.00	ZBR5045MM	107.950	92.08	40.49	65.09	155.58	96.84	11.00	12.70	56.34	65.88	17.46	22.23	3.90												
6	1 15/16	ZBR5115	4.500	3 51/64	1 9/16	2 11/16	6 3/8	3 13/16	7/16	9/16	2 1/4	2 7/8	11/16	7/8	9.60												
	50.00	ZBR5050MM	114.300	96.44	39.69	68.26	161.93	96.84	11.00	14.29	57.15	73.03	17.46	22.23	3.40												
7	2	ZBR5200	5.000	4 1/4	1 3/4	3	7 1/8	4 1/8	1/2	9/16	2 3/8	3 1/4	13/16	1	13.70												
	2 3/16	ZBR5203													13.00												
	55.00	ZBR5055MM	127.000	107.95	44.45	76.20	180.98	104.78	13.00	14.29	60.33	82.60	20.64	25.40	5.90												
8	2 7/16	ZBR5207	5.500	4 19/32	1 13/16	3 1/4	7 5/8	4 3/8	1/2	5/8	2 9/16	3 9/16	7/8	1	15.90												
	60.00	ZBR5060MM													7.20												
	65.00	ZBR5065MM	139.700	116.66	46.04	82.55	193.68	111.13	13.00	15.88	65.09	90.50	22.23	25.40	7.00												
9	2 1/2	ZBR5208	6.375	5 19/64	2	3 3/4	8 3/4	4 7/8	5/8	3/4	2 7/8	4 1/16	7/8	1 1/4	26.10												
	2 11/16	ZBR5211													24.80												
	2 15/16	ZBR5215													22.70												
	70.00	ZBR5070MM													161.925	134.54	50.80	95.25	222.25	123.83	16.00	19.05	73.03	103.20	22.23	31.75	11.20
	75.00	ZBR5075MM													161.925	134.54	50.80	95.25	222.25	123.83	16.00	19.05	73.03	103.20	22.23	31.75	10.30
10	3 3/16	ZBR5303	7.375	6 3/32	2 3/8	4 5/16	10 1/4	5 5/16	3/4	15/16	2 15/16	4 29/32	15/16	1 1/4	38.00												
	3 7/16	ZBR5307													36.50												
	80.00	ZBR5080MM													17.20												
	85.00	ZBR5085MM													187.325	154.79	60.33	109.54	260.35	134.94	19.00	23.81	74.62	124.62	23.81	31.75	17.10
	90.00	ZBR5090MM													187.325	154.79	60.33	109.54	260.35	134.94	19.00	23.81	74.62	124.62	23.81	31.75	17.00
11	3 11/16	ZBR5311	8.125	6 5/8	2 11/16	4 11/16	10 7/8	6 1/8	3/4	1 1/8	3 9/16	5 5/8	1 1/32	1 1/2	56.00												
	3 15/16	ZBR5315													53.00												
	4	ZBR5400													52.00												
	100.00	ZBR5100MM													206.375	168.28	68.26	119.06	276.23	155.58	19.00	28.58	90.48	142.90	26.19	38.10	24.00
6-Bolt																											
12	4 7/16	ZBR5407Y	10.250	5 7/8	2 5/16	5 7/8	13 1/2	6 1/4	3/4	1	3 15/16	6 3/16	1 1/16	2	84.00												
	4 1/2	ZBR5408Y													83.00												
	110.00	ZBR5110MM													260.350	149.23	58.74	149.23	342.90	158.75	19.00	25.40	100.01	157.16	26.99	50.80	39.00
	115.00	ZBR5115MM													260.350	149.23	58.74	149.23	342.90	158.75	19.00	25.40	100.01	157.16	26.99	50.80	38.00
13	4 15/16	ZBR5415	11.000	6 3/8	2 31/32	6 3/8	14 3/4	7 7/8	7/8	1 1/4	4 29/32	7 1/16	1 5/32	2 1/4	128.00												
	5	ZBR5500													125.00												

Continued...



Continued...

Bearing Dimensions

Size Code	Shaft Diameter	Part Number	A Pilot Diameter	B Distance Between Bolt Holes	L Mounting Surface to Collar Face	R Bolt Circle Radius	C	D	F Bolts	H	J	M	P	U	Approx. Weight
6-Bolt (continued)															
13	125.00	ZBR5125MM	279.400	161.93	75.41	161.93	374.65	200.03	22.00	31.75	124.61	179.39	29.37	57.15	58.00
	130.00	ZBR5130MM													57.00
14	5 7/16	ZBR5507	13.000	7 1/4	3 7/32	7 1/4	17	8	7/8	1 3/8	4 25/32	8 3/16	1 7/32	2	184.00
	140.00	ZBR5140MM	330.200	184.15	81.73	184.15	431.80	203.20	22.00	34.93	121.44	207.96	30.96	50.80	83.40
15	5 15/16	ZBR5515	14.000	8 1/4	3 1/16	8 1/4	19	8 1/8	7/8	1	5 1/16	8 5/8	1 5/32	1 3/8	214.00
	6	ZBR5600													213.00
	150.00	ZBR5150MM	355.600	209.55	77.79	209.55	482.60	206.38	22.00	25.40	128.59	219.08	29.37	34.93	97.00
	160.00	ZBR5160MM													95.00
16	6 7/16	ZBR5607	15.000	8 1/2	3 3/8	8 1/2	19	8 3/4	1	1	5 3/8	9 23/32	1 9/32	1 1/2	246.00
	6 15/16	ZBR5615													241.00
	7	ZBR5700	381.000	215.90	85.73	215.90	482.60	222.25	25.00	25.40	136.53	246.86	32.54	38.10	239.00
	180.00	ZBR5180MM													108.00

Additional Notes

Please call 1-866-REXNORD for availability
 Metric bore sizes available, see Rex Interchangeability guide
 Lubrication fitting tap size: for size code 4 thru 11, 1/8" PT; for all other size codes, 1/4" PT
 Bore size = nominal shaft size +.001 in/- .000 in (+0.03 mm/-0.00 mm)
 Pilot Diameter tolerance, +.000 in/- .002 in (+0.00 mm/-0.05 mm) for size codes 4 thru 13
 Pilot Diameter tolerance, +.000"/-.005" for size codes 14 thru 16
 Bore tolerance for mounting, +.002 in/- .000 in (+0.05 mm/-0.00 mm) for size codes 4 thru 13

Bore tolerance for mounting, +.005"/-.000" for size codes 14 thru 16
 Seals - To specify G, K or M seal, replace "Z" in part number with "G", "K" or "M"
 "G" seals only available in size codes 4 thru 13
 "K" seals only available in size codes 4 thru 11
 Auxiliary end caps - available in all size codes
 For the Selection Guide, Load Ratings and Speed Limits, see the Spherical Roller Bearings Engineering section on pages 15 - 27.
 Note: Dimensions subject to change. Certified dimensions of ordered material furnished on request.

ZBR6000

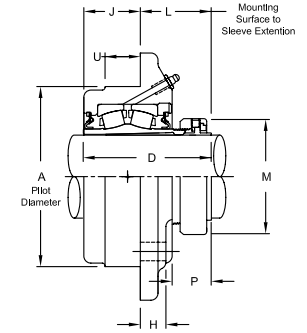
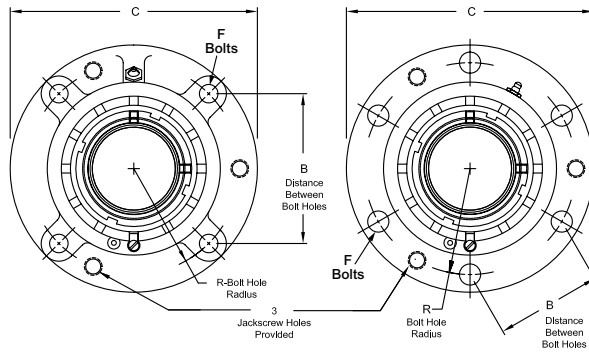
Interchange: FCIP, USFC5000A, USFCE5000A, QVCW, QVVCW



Photo Shows a 4-Bolt Spherical Roller Bearing Flanged Cartridge Unit

Product Features

- Spyglass Optical Strain Sensor (OSS) Technology
- Positive locking system
- Tapered adapter sleeve
- Corrosion-resistant powder coating
- Cast iron housing
- Misalignment capabilities - total of 4°
- Broad range of sealing options
- Factory set clearance & lubrication
- Precision ground & superfinished raceways
- See Features and Benefits for additional info on pages 10 - 13.



Bearing Dimensions

Size Code	Shaft Diameter	Part Number	A Pilot Diameter	B Distance Between Bolt Holes	L Mounting Surface to Collar Face	R Bolt Circle Radius	C	D	F Bolts	H	J	M	P	U	Approx. Weight												
4-Bolt																											
4	1 7/16	ZBR6107	3.625	3 3/32	1 61/64	2 3/16	5 1/4	3 21/64	3/8	1/2	1 3/8	2 25/64	1 9/64	3/4	5.40												
5	1 11/16	ZBR6111	4.250	3 5/8	2 3/16	2 9/16	6 1/8	3 47/64	7/16	1/2	1 17/32	2 41/64	1 9/32	7/8	8.40												
6	1 15/16	ZBR6115	4.500	3 51/64	2	2 11/16	6 3/8	3 41/64	7/16	9/16	1 9/16	2 55/64	1 1/8	7/8	9.60												
	45.00	ZBR6045MM	114.300	96.44	50.80	68.26	161.93	92.47	11.00	14.29	39.69	72.63	28.58	22.23	4.40												
7	2 3/16	ZBR6203	5.000	4 1/4	2 7/64	3	7 1/8	3 11/16	1/2	9/16	1 9/16	3 15/64	1 5/32	1	13.70												
	55.00	ZBR6055MM	127.000	107.95	53.57	76.20	180.98	93.66	13.00	14.29	39.69	82.15	29.37	25.40	5.90												
8	2 3/8	ZBR6206	5.500	4 19/32	2 23/64	3 1/4	7 5/8	4 1/16	1/2	5/8	1 11/16	3 19/32	1 27/64	1	16.20												
	2 7/16	ZBR6207													15.90												
	60.00	ZBR6060MM													139.700	116.66	59.92	82.55	193.68	103.19	13.00	15.88	42.86	91.28	36.12	25.40	7.20
9	2 11/16	ZBR6211	6.375	5 19/64	2 17/32	3 3/4	8 3/4	4 17/32	5/8	3/4	2	4 3/32	1 25/64	1 1/4	26.10												
	2 3/4	ZBR6212													24.80												
	2 15/16	ZBR6215													22.70												
	70.00	ZBR6070MM													161.925	134.54	64.29	95.25	222.25	115.09	16.00	19.05	50.80	103.98	35.32	31.75	11.20
	75.00	ZBR6075MM																									10.30
10	3 3/16	ZBR6303	7.375	6 3/32	3 1/32	4 5/16	10 1/4	5 1/32	3/4	15/16	2	4 61/64	1 19/32	1 1/4	38.00												
	3 7/16	ZBR6307													36.50												
	80.00	ZBR6080MM													187.325	154.79	76.99	109.54	260.35	127.79	19.00	23.81	50.80	125.81	40.48	31.75	17.20
	85.00	ZBR6085MM																									17.10
11	3 11/16	ZBR6311	8.125	6 5/8	3 23/64	4 11/16	10 7/8	5 25/32	3/4	1 1/8	2 1/2	5 43/64	1 47/64	1 1/2	56.00												
	3 15/16	ZBR6315													53.00												
	90.00	ZBR6090MM													206.375	168.28	85.32	119.06	276.23	146.84	19.00	28.58	63.50	144.07	44.05	38.10	24.00
	100.00	ZBR6100MM																									
6-Bolt																											
12	4 3/16	ZBR6403Y	10.250	5 7/8	3 3/16	5 7/8	13 1/2	6 1/4	3/4	1	3 1/16	6 1/16	1 7/8	2	84.00												
	4 7/16	ZBR6407Y													83.00												
	110.00	ZBR6110MM													260.350	149.23	80.96	149.23	342.90	158.75	19.00	25.40	77.79	153.99	47.63	50.80	39.00
13	4 15/16	ZBR6415	11.000	6 3/8	4 1/16	6 3/8	14 3/4	7 15/16	7/8	1 1/4	3 7/8	6 61/64	2 1/4	2 1/4	128.00												
	125.00	ZBR6125MM	279.400	161.93	403.19	161.93	374.65	201.61	22.00	31.75	98.43	176.61	57.15	57.15	58.00												
14	5 7/16	ZBR6507	13.000	7 1/4	5 1/16	7 1/4	17	8 49/64	7/8	1 3/8	3 7/8	8 1/64	3 3/64	2	184.00												
15	5 15/16	ZBR6515	14.000	8 1/4	5 23/64	8 1/4	19	9 19/64	7/8	1	4 3/16	8 21/32	3 7/16	1 3/8	214.00												
16	6 7/16	ZBR6607	15.000	8 1/2	5 53/64	8 1/2	19	10	1	1	4 1/4	9 3/4	3 43/64	1 1/2	246.00												
	6 15/16	ZBR6615													241.00												

Additional Notes

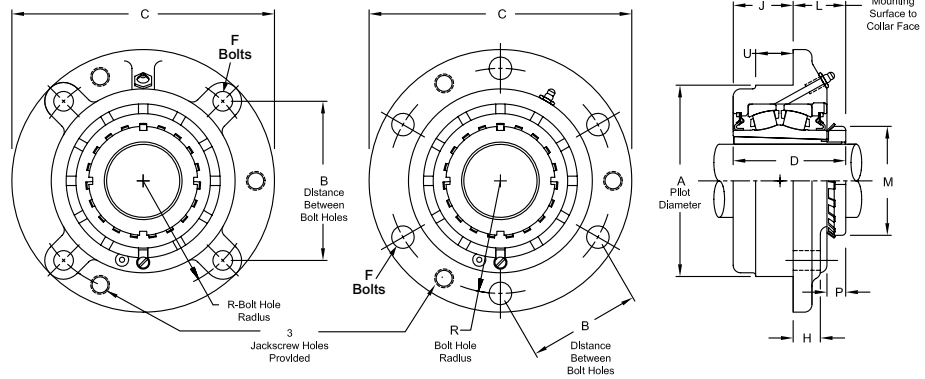
- Please call 1-866-REXNORD for availability
- Lubrication fitting tap size: for size code 6 thru 11, 1/8" PT; for all other size codes, 1/4" PT
- Pilot Diameter tolerance, +.000 in/- .002 in (+0.00 mm/-0.05 mm)
- Bore tolerance for mounting, +.002 in/- .000 in (+0.05 mm/-0.00 mm)
- Seals - To specify G, K or M seal, replace "Z" in part number with "G", "K" or "M"
- "G" seals only available in size codes 4 thru 13

- "K" seals only available in size codes 4 thru 11
- Auxiliary end caps - available in all size codes
- For the Selection Guide, Load Ratings and Speed Limits, see the Spherical Roller Bearings Engineering section on pages 15 - 27.
- Note: Dimensions subject to change. Certified dimensions of ordered material furnished on request.

ZBR9000



Photo Shows a 4-Bolt Spherical Roller Bearing Flanged Cartridge Unit



Product Features

- Corrosion-resistant powder coating
- Cast iron housing
- Misalignment capabilities - total of 4°
- Broad range of sealing options
- Factory set clearance & lubrication
- Precision ground & superfinished raceways
- Enhanced life mounting style
- Field interchangeable seals
- See Features and Benefits for additional info on pages 10 - 13.

Bearing Dimensions

Size Code	Shaft Diameter	Part Number	A Pilot Diameter	B Distance Between Bolt Holes	L Mounting Surface to Collar Face	R Bolt circle Radius	C	D	F Bolts	H	J	M	P	U	Approx. Weight												
4-Bolt																											
7	1 15/16	ZBR9115	5.000	4 1/4	1 19/32	3	7 1/8	3 5/32	1/2	9/16	1 9/16	2 31/32	19/32	1	12.20												
	2	ZBR9200													12.10												
	45.00	ZBR9045MM													127.000	107.95	40.49	76.20	180.98	80.17	13.00	14.29	39.69	75.40	15.08	25.40	5.50
	50.00	ZBR9050MM													5.30												
8	2 3/16	ZBR9203	5.500	4 19/32	1 21/32	3 1/4	7 5/8	3 11/32	1/2	5/8	1 11/16	3 3/8	23/32	1	15.20												
	55.00	ZBR9055MM	139.700	116.66	42.06	82.55	193.68	84.93	13.00	15.88	42.86	85.73	18.26	25.40	6.90												
9	2 7/16	ZBR9207	6.375	5 19/64	1 3/4	3 3/4	8 3/4	3 3/4	5/8	3/4	2	3 5/8	5/8	1 1/4	22.70												
	2 1/2	ZBR9208													22.30												
10	2 11/16	ZBR9211	7.375	6 3/32	2 1/4	4 5/16	10 1/4	4 1/4	3/4	15/16	2	4 13/32	13/16	1 1/4	36.40												
	2 15/16	ZBR9215													35.40												
	3	ZBR9300													34.70												
	75.00	ZBR9075MM													187.325	154.79	57.15	109.54	260.35	107.95	19.00	23.81	50.80	111.92	20.64	31.75	16.00
11	3 3/16	ZBR9303	8.125	6 5/8	2 9/16	4 11/16	10 7/8	5	3/4	1 1/8	2 1/2	5 3/16	15/16	1 1/2	55.50												
	3 7/16	ZBR9307													53.50												
	80.00	ZBR9080MM													206.375	168.28	65.09	119.06	276.23	127.00	19.00	28.58	63.50	131.76	23.81	38.10	25.00
6-Bolt																											
12	3 11/16	ZBR9311Y	10.250	5 7/8	2 11/32	5 7/8	13 1/2	5 17/32	3/4	1	3 1/16	5 23/32	1 1/32	2	84.20												
	3 15/16	ZBR9315Y													81.90												
	4	ZBR9400Y													81.40												
	100.00	ZBR9100MM													260.350	149.23	59.52	149.23	342.90	140.49	19.00	25.40	77.79	145.26	26.19	50.80	37.00
13	4 3/16	ZBR9403	11.000	6 3/8	2 7/8	6 3/8	14 3/4	6 3/4	7/8	1 1/4	3 7/8	6 1/8	1 1/8	2 1/4	128.00												
	4 7/16	ZBR9407													126.00												
14	4 15/16	ZBR9415	13.000	7 1/4	3 5/16	7 1/4	17	7 1/16	7/8	1 3/8	3 7/8	7 3/32	1 1/8	2	178.00												
	5	ZBR9500													177.00												
15	5 7/16	ZBR9507	14.000	8 1/4	3 3/8	8 1/4	19	7 5/16	7/8	1	4 3/16	8 1/16	1 5/16	1 3/8	209.00												
	5 15/16	ZBR9515													241.00												
16	6	ZBR9600	15.000	8 1/2	3 1/2	8 1/2	19	7 3/4	1	1	4 1/4	9 1/16	1 11/16	1 1/2	240.00												
	6 7/16	ZBR9607													233.00												

Additional Notes

- Please call 1-866-REXNORD for availability
- Lubrication fitting tap size: for size code 7 thru 11, 1/8" PT; for all other size codes, 1/4" PT
- Pilot Diameter tolerance, +.000 in/-.002 in (+0.00 mm/-0.05 mm) for size codes 7 thru 13
- Pilot Diameter tolerance, +.005 in/-.000 in (+0.13 mm/-0.00 mm) for size codes 14 thru 16
- Bore tolerance for mounting, +.002 in/-.000 in (+0.05 mm/-0.00 mm) for size codes 7 thru 13

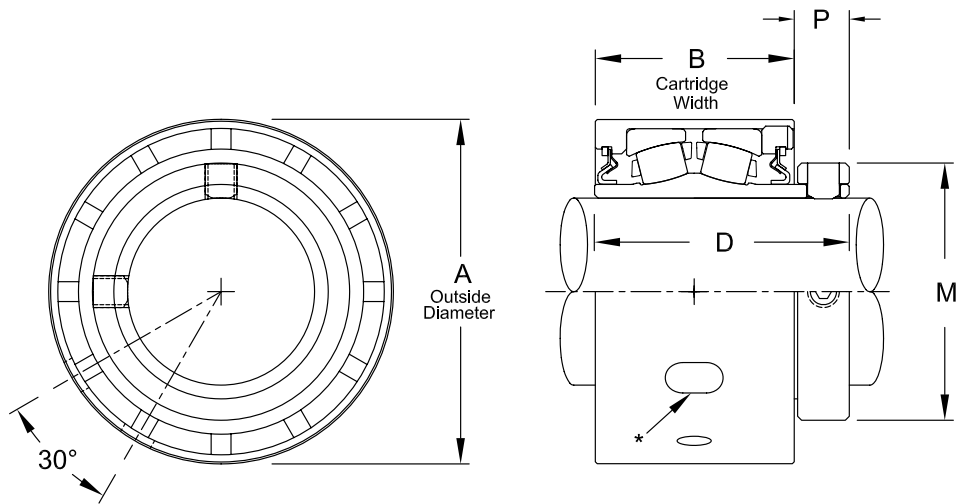
- Bore tolerance for mounting, +.005 in/-.000 in (+0.13 mm/-0.00 mm) for size codes 14 thru 16
- Seals - To specify G, K or M seal, replace "Z" in part number with "G", "K" or "M"
- "G" seals only available in size codes 7 thru 13
- "K" seals only available in size codes 7 thru 11
- Auxiliary end caps - available in all size codes
- For the Selection Guide, Load Ratings and Speed Limits, see the Spherical Roller Bearings Engineering section on pages 15 - 27.
- Note: Dimensions subject to change. Certified dimensions of ordered material furnished on request.



Photo Shows a Spherical Roller Bearing Cartridge Unit with Steel Housing

Product Features

- Steel housing
- Misalignment capabilities - total of 4°
- Broad range of sealing options
- Factory set clearance & lubrication
- Precision ground & superfinished raceways
- Hardened spring locking collar
- Field interchangeable seals
- See Features and Benefits for additional info on pages 10 - 13.



Bearing Dimensions

Size Code	Shaft Diameter	Part Number	A Outside Diameter	B Cartridge Length	D	M	P	Approx. Weight
4	1 7/16	ZCS2107	3.1240	2.188	2 7/8	2 5/16	11/16	2.90
	1 1/2	ZCS2108						2.80
	35.00	ZCS2035MM						79.3500
5	1 11/16	ZCS2111	3.6360	2.438	3.13	2 19/32	11/16	4.50
	1 3/4	ZCS2112						4.40
	40.00	ZCS2040MM	92.3500	61.930	79.38	65.88	17.46	2.50
	45.00	ZCS2045MM						
6	1 15/16	ZCS2115	3.8330	2.391	3 1/8	2 7/8	11/16	5.00
	2	ZCS2200						4.80
	50.00	ZCS2050MM						97.3600
7	2 3/16	ZCS2203	4.2270	2.500	3 5/16	3 1/4	13/16	6.40
	2 1/4	ZCS2204						6.30
	55.00	ZCS2055MM						107.3600
8	2 3/8	ZCS2206	4.6210	2.625	3 1/2	3 9/16	7/8	7.60
	2 7/16	ZCS2207						7.50
	2 1/2	ZCS2208						7.30
	60.00	ZCS2060MM	117.3700	66.680	88.90	90.50	22.23	3.90
	65.00	ZCS2065MM						
9	2 11/16	ZCS2211	5.4070	3.125	4.00	4 1/16	7/8	12.30
	2 3/4	ZCS2212						11.90
	2 15/16	ZCS2215						10.80
	3	ZCS2300	10.50					
	70.00	ZCS2070MM	137.3380	79.380	101.60	103.20	22.23	6.40
	75.00	ZCS2075MM						5.90
10	3 3/16	ZCS2303	6.1940	3.438	4 3/8	4 29/32	15/16	17.90
	3 7/16	ZCS2307						16.40
	3 1/2	ZCS2308						15.90
	80.00	ZCS2080MM						9.00
	85.00	ZCS2085MM	157.3300	87.330	111.13	124.62	23.81	8.60
	90.00	ZCS2090MM						8.20
11	3 11/16	ZCS2311	7.3750	4.000	5 1/16	5 5/8	1 1/32	31.10
	3 15/16	ZCS2315						28.80
	4	ZCS2400						28.10
	100.00	ZCS2100MM						187.3200

Additional Notes

- Please call 1-866-REXNORD for availability
- O.D. tolerance, +.000 in/-.002 in (**+0.00 mm/-0.05 mm**)
- Bore tolerance for mounting, +.002 in/-.000 in (**+0.05 mm/-0.00 mm**)
- Expansion - is 3/8 in for all size codes
- *Expansion plug diameter .531 in (**13.49 mm**), engagement depth .125 in +/- .015 in (**3.18 mm +/- 0.38 mm**)
- Hole for fixed location & slot for expansion location in the same housing

- Seals - to specify G, K or M seal, replace "Z" in part number with "G", "K" or "M"
- Auxiliary end caps - not available
- For the Selection Guide, Load Ratings and Speed Limits, see the Spherical Roller Bearings Engineering section on pages 15 - 27.
- Note: Dimensions subject to change. Certified dimensions of ordered material furnished on request.

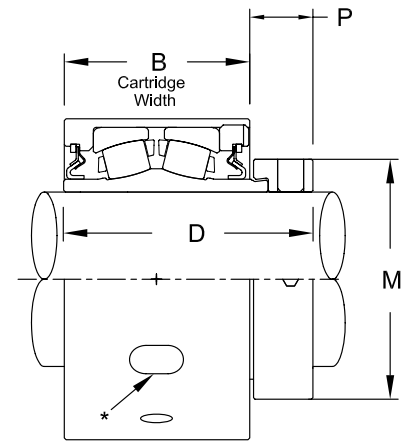
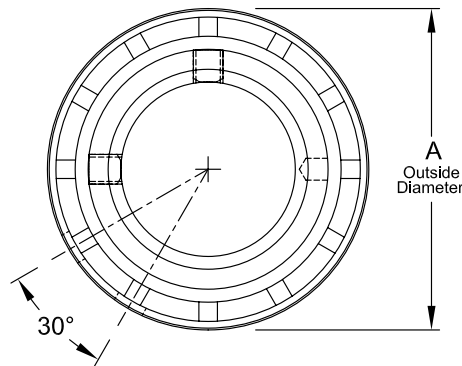
ZCS3000



Photo Shows a Spherical Roller Bearing Cartridge Unit with Steel Housing

Product Features

- Steel housing
- Misalignment capabilities - total of 4°
- Broad range of sealing options
- Factory set clearance & lubrication
- Precision ground & superfinished raceways
- Eccentric locking collar
- Field interchangeable seals
- See Features and Benefits for additional info on pages 10 - 13.



Bearing Dimensions

Size Code	Shaft Diameter	Part Number	A Outside Diameter	B Cartridge Length	D	M	P	Approx. Weight
4	1 ⁷ / ₁₆	ZCS3107	3.1240	2.188	2 ⁵⁹ / ₆₄	2 ⁵ / ₁₆	²⁵ / ₃₂	3.10
5	1 ¹¹ / ₁₆	ZCS3111	3.6360	2.438	3 ³ / ₁₆	2 ⁵ / ₈	³ / ₄	4.70
6	1 ¹⁵ / ₁₆	ZCS3115	3.8330	2.391	3 ⁹ / ₃₂	2 ³ / ₄	²⁷ / ₃₂	3.50
7	2 ³ / ₁₆	ZCS3203	4.2270	2.500	3 ¹ / ₂	3 ¹ / ₄	³¹ / ₃₂	6.70
8	2 ⁷ / ₁₆	ZCS3207	4.6210	2.625	3 ²¹ / ₃₂	3 ⁹ / ₁₆	1 ¹ / ₆₄	7.70
	2 ¹ / ₂	ZCS3208						7.60
9	2 ¹¹ / ₁₆	ZCS3211	5.4070	3.125	4 ¹³ / ₆₄	4 ¹ / ₁₆	1 ¹ / ₆₄	12.50
	2 ¹⁵ / ₁₆	ZCS3215						11.50
10	3 ⁷ / ₁₆	ZCS3307	6.1940	3.438	4 ³⁷ / ₆₄	4 ¹⁵ / ₁₆	1 ⁹ / ₆₄	17.00
	3 ¹ / ₂	ZCS3308						16.10
11	3 ¹⁵ / ₁₆	ZCS3315	7.3740	4.000	5 ³ / ₁₆	5 ⁵ / ₈	1 ¹ / ₁₆	28.80

Additional Notes

- Please call 1-866-REXNORD for availability
- O.D. tolerance, +.000 in/-.002 in (**+0.00 mm/-0.05 mm**)
- Bore tolerance for mounting, +.002 in/-.000 in (**+0.05 mm/-0.00 mm**)
- Expansion - is 3/8 in for all size codes
- *Expansion plug diameter .531 in (**13.49 mm**), engagement depth .125 in +/- .015 in (**3.18 mm +/- 0.38 mm**)
- Hole for fixed location & slot for expansion location in the same housing
- Seals - to specify G, K or M seal, replace "Z" in part number with "G", "K" or "M"

- Auxiliary end caps - not available
- For the Selection Guide, Load Ratings and Speed Limits, see the Spherical Roller Bearings Engineering section on pages 15 - 27.
- Note: Dimensions subject to change. Certified dimensions of ordered material furnished on request.

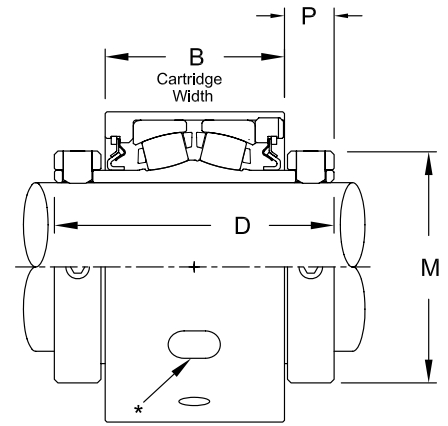
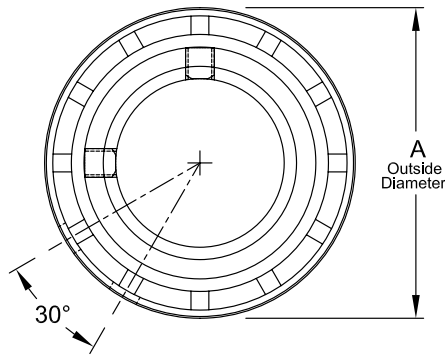
ZCS5000



Photo Shows a Spherical Roller Bearing Cartridge Unit with Steel Housing

Product Features

- Steel housing
- Misalignment capabilities - total of 4°
- Broad range of sealing options
- Factory set clearance & lubrication
- Precision ground & superfinished raceways
- Two hardened spring locking collars
- Field interchangeable seals
- See Features and Benefits for additional info on pages 10 - 13.



Bearing Dimensions

Size Code	Shaft Diameter	Part Number	A Outside Diameter	B Cartridge Length	D	M	P	Approx. Weight
4	1 7/16	ZCS5107	3.1240	2.188	3 9/16	2 5/16	11/16	3.30
	35.00	ZCS5035MM	79.3500	55.580	90.49	58.74	17.46	1.50
5	1 1/2	ZCS5108	3.6360	2.438	3 13/16	2 19/32	11/16	5.70
	40.00	ZCS5040MM	92.3500	61.930	96.84	65.88	17.46	5.10
	45.00	ZCS5045MM						2.59
6	1 15/16	ZCS5115	3.8330	2.391	3 13/16	2 7/8	11/16	2.55
	50.00	ZCS5050MM	97.3600	61.730	96.84	73.03	17.46	5.30
7	2	ZCS5200	4.2270	2.500	4 1/8	3 1/4	13/16	2.40
	2 3/16	ZCS5203						8.10
	55.00	ZCS5055MM	107.3600	63.500	104.78	82.60	20.64	7.50
8	2 7/16	ZCS5207	4.6210	2.625	4 3/8	3 9/16	7/8	3.40
	60.00	ZCS5060MM	117.3700	66.680	111.13	90.50	22.23	8.70
	65.00	ZCS5065MM						4.08
9	2 1/2	ZCS5208						4.20
	2 11/16	ZCS5211	5.4070	3.125	4 7/8	4 1/16	7/8	15.10
	2 15/16	ZCS5215						14.10
	70.00	ZCS5070MM	137.3380	79.380	123.83	103.20	22.23	12.10
	75.00	ZCS5075MM						6.40
10	3 3/16	ZCS5303	6.1940	3.438	5 5/16	4 29/32	15/16	6.00
	3 7/16	ZCS5307						19.80
	80.00	ZCS5080MM	157.3300	88.140	134.94	124.62	23.81	17.90
	85.00	ZCS5085MM						8.90
	90.00	ZCS5090MM						8.50
11	3 11/16	ZCS5311	7.3750	4	6 1/8	5 5/8	1 1/32	8.10
	3 15/16	ZCS5315						33.60
	4	ZCS5400						32.60
	100.00	ZCS5100MM	187.3200	101.600	155.58	142.90	26.19	31.60
								14.80
12	4 3/16	ZCS5403Y	7.9685	4 1/4	6 1/4	6 3/16	1 1/16	44.00
	4 7/16	ZCS5407Y						40.00
	4 1/2	ZCS5408Y						39.50
	110.00	ZCS5110MM	202.4000	107.950	158.75	157.16	26.99	20.00
	115.00	ZCS5115MM						18.00
13	4 15/16	ZCS5415	9.3442	5.560	7 7/8	7 1/16	1 5/32	54.00
	5	ZCS5500						53.50
	125.00	ZCS5125MM	237.3400	141.220	200.03	179.39	29.37	24.50
	130.00	ZCS5130MM						24.25

Additional Notes

- Please call 1-866-REXNORD for availability
- O.D. tolerance, Size Code 11 and smaller +.000 in/-.002 in (+0.00 mm/-0.05 mm)
- O.D. tolerance, Size Code 12 and larger +.000 in/-.003 in (+0.00 mm/-0.08 mm)
- Bore tolerance for mounting, +.002 in/-.000 in (+0.05 mm/-0.00 mm)
- Expansion - is 3/8 in for all size codes
- *Expansion plug diameter .531 in (13.49 mm), engagement depth .125 in +/- .015 in (3.18 mm +/- 0.38 mm)

- Hole for fixed location & slot for expansion location in the same housing
- Seals - to specify G, K or M seal, replace "Z" in part number with "G", "K" or "M"
- "K" seals available in size codes 4 thru 11
- Auxiliary end caps - not available
- For the Selection Guide, Load Ratings and Speed Limits, see the Spherical Roller Bearings Engineering section on pages 15 - 27.
- Note: Dimensions subject to change. Certified dimensions of ordered material furnished on request.

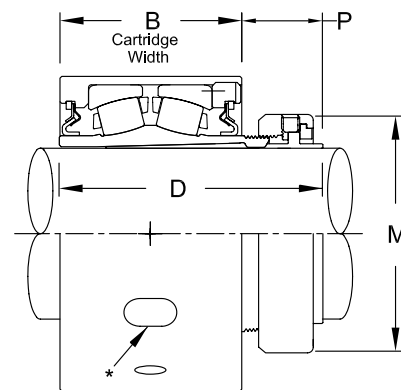
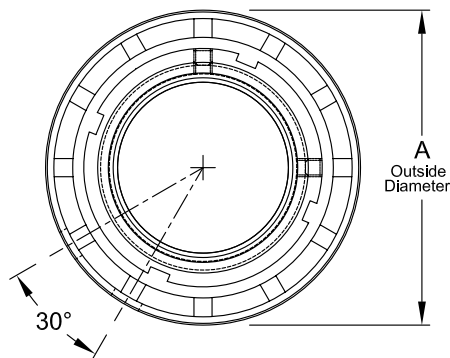
ZCS6000



Photo Shows a Spherical Roller Bearing Cartridge Unit with Steel Housing

Product Features

- Spyglass Optical Strain Sensor (OSS) Technology
- Positive locking system
- Tapered adapter sleeve
- Steel housing
- Misalignment capabilities - total of 4°
- Broad range of sealing options
- Factory set clearance & lubrication
- Precision ground & superfinished raceways
- Field interchangeable seals
- See Features and Benefits for additional info on pages 10 - 13.



Bearing Dimensions

Size Code	Shaft Diameter	Part Number	A Outside Diameter	B Cartridge Length	D	M	P	Approx. Weight
4	1 ⁷ / ₁₆	ZCS6107	3.1240	2.188	3 ²¹ / ₆₄	2 ²⁵ / ₆₄	1 ⁹ / ₆₄	2.90
5	1 ¹¹ / ₁₆	ZCS6111	3.6360	2.438	3 ⁴⁷ / ₆₄	2 ⁴¹ / ₆₄	1 ⁹ / ₃₂	4.50
6	1 ¹⁵ / ₁₆	ZCS6115	3.8330	2.391	3 ⁴¹ / ₆₄	2 ⁵⁵ / ₆₄	1 ¹ / ₈	5.30
	45.00	ZCS6045MM	97.3600	60.730	92.47	72.63	28.58	2.55
7	2 ³ / ₁₆	ZCS6203	4.2270	2.500	3 ¹¹ / ₁₆	3 ¹⁵ / ₆₄	1 ⁵ / ₃₂	8.10
	55.00	ZCS6055MM	107.3600	65.020	93.66	82.15	29.37	3.40
8	2 ³ / ₈	ZCS6206	4.6210	2.625	4 ¹ / ₁₆	3 ¹⁹ / ₃₂	1 ²⁷ / ₆₄	9.10
	2 ⁷ / ₁₆	ZCS6207						8.70
	60.00	ZCS6060MM	117.3700	66.680	103.19	91.28	36.12	4.08
9	2 ¹¹ / ₁₆	ZCS6211	5.4070	3.125	4 ¹⁷ / ₃₂	4 ³ / ₃₂	1 ²⁵ / ₆₄	15.10
	2 ³ / ₄	ZCS6212						14.10
	2 ¹⁵ / ₁₆	ZCS6215						12.10
	70.00	ZCS6070MM						137.3380
	75.00	ZCS6075MM						
10	3 ³ / ₁₆	ZCS6303	6.1940	3.438	5 ¹ / ₃₂	4 ⁶¹ / ₆₄	1 ¹⁹ / ₃₂	19.80
	3 ⁷ / ₁₆	ZCS6307						17.90
	80.00	ZCS6080MM	157.3300	88.140	127.79	125.81	40.48	8.90
	85.00	ZCS6085MM						8.50
11	3 ¹¹ / ₁₆	ZCS6311	7.3750	4	5 ²⁵ / ₃₂	5 ⁴³ / ₆₄	1 ⁴⁷ / ₆₄	33.60
	3 ¹⁵ / ₁₆	ZCS6315						32.60
	90.00	ZCS6090MM	187.3200	101.600	146.84	144.07	44.05	14.80
	100.00	ZCS6100MM						
12	4 ³ / ₁₆	ZCS6403Y	7.9685	4 ¹ / ₄	6 ¹ / ₄	6 ¹ / ₁₆	1 ⁷ / ₈	40.00
	4 ⁷ / ₁₆	ZCS6407Y						39.50
	110.00	ZCS6110MM	202.4000	107.950	158.75	153.99	47.63	20.00
13	4 ¹⁵ / ₁₆	ZCS6415	9.3442	5.560	7 ¹⁵ / ₁₆	6 ⁶¹ / ₆₄	2 ¹ / ₄	54.00
	125.00	ZCS6125MM	237.3400	141.220	201.61	176.61	57.15	24.50

Additional Notes

- Please call 1-866-REXNORD for availability
- O.D. tolerance, Size Code 11 and smaller +.000 in/-.002 in (+0.00 mm/-0.05 mm)
- O.D. tolerance, Size Code 12 and larger +.000 in/-.003 in (+0.00 mm/-0.08 mm)
- Bore tolerance for mounting, +.002 in/-.000 in (+0.05 mm/-0.00 mm)
- Expansion - is 3/8 in for all size codes
- *Expansion plug diameter .531 in (13.49 mm), engagement depth .125 in +/- .015 in (3.18 mm +/- 0.38 mm)

- Hole for fixed location & slot for expansion location in the same housing
- Seals - to specify G, K or M seal, replace "Z" in part number with "G", "K" or "M"
- "K" seals available in size codes 4 thru 11
- Auxiliary end caps - not available
- For the Selection Guide, Load Ratings and Speed Limits, see the Spherical Roller Bearings Engineering section on pages 15 - 27.
- Note: Dimensions subject to change. Certified dimensions of ordered material furnished on request.

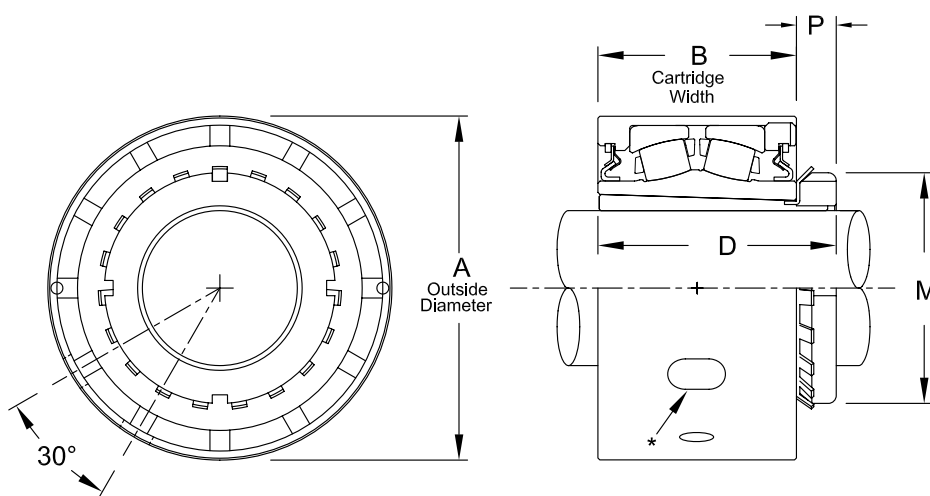
ZCS9000



Photo Shows a Spherical Roller Bearing Cartridge Unit with Steel Housing

Product Features

- Steel housing
- Misalignment capabilities - total of 4°
- Broad range of sealing options
- Factory set clearance & lubrication
- Precision ground & superfinished raceways
- Enhanced life mounting style
- Field interchangeable seals
- See Features and Benefits for additional info on pages 10 - 13.



Bearing Dimensions

Size Code	Shaft Diameter	Part Number	A Outside Diameter	B Cartridge Length	D	M	P	Approx. Weight
7	1 ¹⁵ / ₁₆	ZCS9115	4.2270	2.500	3 ⁵ / ₃₂	2 ³¹ / ₃₂	19/ ₃₂	6.60
	2	ZCS9200						6.50
	45.00	ZCS9045MM	107.3600	65.020	80.17	75.40	15.08	2.90
	50.00	ZCS9050MM						3.10
8	2 ³ / ₁₆	ZCS9203	4.6210	2.625	3 ¹¹ / ₃₂	3 ³ / ₈	23/ ₃₂	7.90
	55.00	ZCS9055MM	117.3700	66.680	84.93	85.73	18.26	3.60
9	2 ⁷ / ₁₆	ZCS9207	5.4070	3.125	3 ³ / ₄	3 ⁵ / ₈	5/ ₈	11.60
	2 ¹ / ₂	ZCS9208						11.20
10	2 ¹¹ / ₁₆	ZCS9211	6.1940	3.438	4 ¹ / ₄	4 ¹³ / ₃₂	13/ ₁₆	19.10
	2 ¹⁵ / ₁₆	ZCS9215						17.90
	3	ZCS9300						17.20
	75.00	ZCS9075MM						157.3300
11	3 ³ / ₁₆	ZCS9303	7.3750	4	5	5 ³ / ₁₆	15/ ₁₆	34.30
	3 ⁷ / ₁₆	ZCS9307						32.30
	80.00	ZCS9080MM						187.3200
12	3 ¹¹ / ₁₆	ZCS9311Y	7.9685	4 ¹ / ₄	5 ¹⁷ / ₃₂	5 ²³ / ₃₂	1 ¹ / ₃₂	44.00
	3 ¹⁵ / ₁₆	ZCS9315Y						40.00
	4	ZCS9400Y						39.50
	100.00	ZCS9100MM						202.4000
13	4 ³ / ₁₆	ZCS9403	9.3442	5.562	6 ³ / ₄	6 ¹ / ₈	1 ¹ / ₈	54.00
	4 ⁷ / ₁₆	ZCS9407						53.50

Additional Notes

- Please call 1-866-REXNORD for availability
- O.D. tolerance, Size Code 11 and smaller +.000 in/-.002 in (+0.00 mm/-0.05 mm)
- O.D. tolerance, Size Code 12 and larger +.000 in/-.003 in (+0.00 mm/-0.08 mm)
- Bore tolerance for mounting, +.002 in/-.000 in (+0.05 mm/-0.00 mm)
- Expansion - is 3/8 in for all size codes
- *Expansion plug diameter .531 in (13.49 mm), engagement depth .125 in +/- .015 in (3.18 mm +/- 0.38 mm)
- Hole for fixed location & slot for expansion location in the same housing

- Seals - to specify G, K or M seal, replace "Z" in part number with "G", "K" or "M"
- "K" seals available in size codes 4 thru 11
- Auxiliary end caps - not available
- For the Selection Guide, Load Ratings and Speed Limits, see the Spherical Roller Bearings Engineering section on pages 15 - 27.
- Note: Dimensions subject to change. Certified dimensions of ordered material furnished on request.

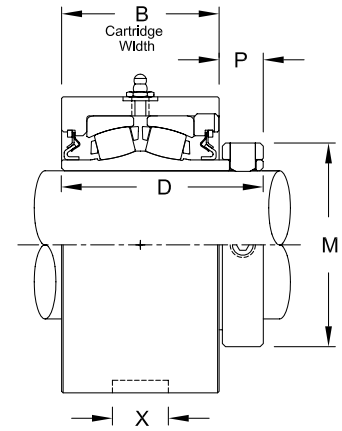
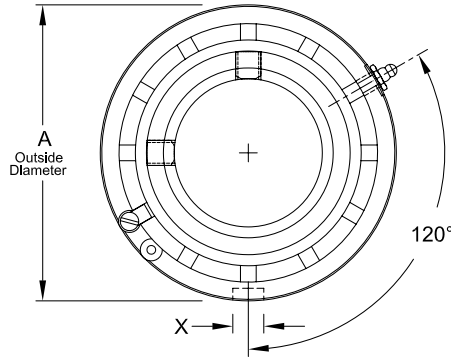
ZMC2000



Photo Shows a Spherical Roller Bearing Cartridge Unit with Cast Iron Housing

Product Features

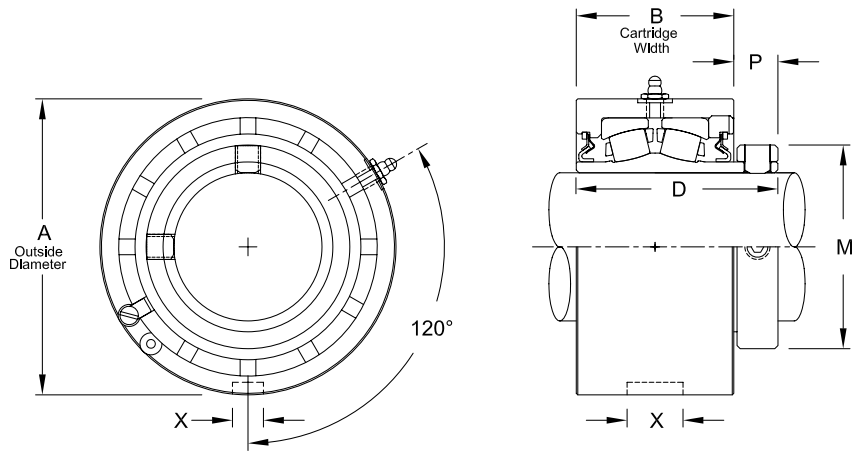
- Corrosion-resistant powder coating
- Cast iron housing
- Misalignment capabilities - total of 4°
- Broad range of sealing options
- Factory set clearance & lubrication
- Precision ground & superfinished raceways
- Hardened spring locking collar
- Field interchangeable seals
- See Features and Benefits for additional info on pages 10 - 13.



Bearing Dimensions

Size Code	Shaft Diameter	Part Number	A Outside Diameter	B Cartridge Length	D	M	P	X Depth	X Length	X Width	Approx. Weight
2	3/4	ZMC2012	3.0000	2	2 9/16	1 3/4	9/16	-	-	-	3.10
	15/16	ZMC2015									2.90
	1	ZMC2100									2.50
3	25.00	ZMC2025MM	76.2000	50.800	65.09	44.45	14.29	-	-	-	1.30
	1 1/8	ZMC2102	3.2190	2 1/8	2 11/16	1 31/32	9/16	-	-	-	3.50
	1 3/16	ZMC2103									3.40
	1 1/4	ZMC2104									3.30
30.00	ZMC2030MM	81.7600	53.980	68.26	50.00	14.29	-	-	-	1.60	
4	1 7/8	ZMC2107	3.4370	2 3/16	2 7/8	2 5/16	11/16	3/16	29/32	0.531	3.90
	1 1/2	ZMC2108									3.80
	35.00	ZMC2035MM									87.3000
5	1 11/16	ZMC2111	3.9370	2 7/16	3 1/8	2 19/32	11/16	3/16	29/32	0.531	5.60
	1 3/4	ZMC2112									5.40
	40.00	ZMC2040MM									100.0000
	45.00	ZMC2045MM	115.0880	65.090	84.14	82.60	19.84	4.76	23.02	13.460	2.30
6	1 15/16	ZMC2115	4.1250	2 7/16	3 1/8	2 7/8	11/16	3/16	29/32	0.531	5.80
	2	ZMC2200									5.60
	50.00	ZMC2050MM									104.7800
7	2 3/16	ZMC2203	4.5310	2 9/16	3 5/16	3 1/4	13/16	3/16	29/32	0.531	7.50
	2 1/4	ZMC2204									7.30
	55.00	ZMC2055MM									115.0880
8	2 3/8	ZMC2206	5.0000	2 5/8	3 1/2	3 9/16	7/8	3/16	29/32	0.531	9.50
	2 7/16	ZMC2207									9.40
	2 1/2	ZMC2208									9.20
	60.00	ZMC2060MM	127.0000	66.680	88.90	90.50	22.23	4.76	23.02	13.490	4.80
	65.00	ZMC2065MM	149.2250	79.380	101.60	103.20	22.23	6.35	26.19	15.090	4.40
9	2 11/16	ZMC2211	5.8750	3 1/8	4	4 1/16	7/8	1/4	1 1/32	0.594	15.90
	2 3/4	ZMC2212									15.50
	2 15/16	ZMC2215									14.40
	3	ZMC2300									14.10
	70.00	ZMC2070MM									149.2250
75.00	ZMC2075MM	170.0000	82.600	104.80	106.40	22.23	6.35	26.19	15.090	7.80	
10	3 3/16	ZMC2303	6.7500	3 7/16	4 3/8	4 29/32	15/16	9/32	1 1/16	0.594	22.50
	3 7/16	ZMC2307									20.50

Continued...



Continued...

Bearing Dimensions

Size Code	Shaft Diameter	Part Number	A Outside Diameter	B Cartridge Length	D	M	P	X Depth	X Length	X Width	Approx. Weight
10	3 1/2	ZMC2308	6.7500	3 7/16	4 3/8	4 29/32	15/16	9/32	1 1/16	0.594	20.00
	80.00	ZMC2080MM									11.20
	85.00	ZMC2085MM	171.4500	87.310	111.13	124.62	23.81	6.35	26.19	15.090	11.00
	90.00	ZMC2090MM									10.80
11	3 11/16	ZMC2311									38.50
	3 15/16	ZMC2315	8.1250	4 1/8	5 1/16	5 5/8	1 1/32	5/16	1 9/32	0.781	36.50
	4	ZMC2400									35.80
	100.00	ZMC2100MM	206.3750	104.780	128.59	142.90	26.19	7.94	32.54	19.830	16.60

Additional Notes

Please call 1-866-REXNORD for availability
 Metric bore sizes available, see Rex Interchangeability guide
 Lubrication fitting tap size, 1/8 PT
 Bore size = nominal shaft size +.001 in/-.000 in (+0.03 mm/-0.00 mm)
 O.D. tolerance, +.000 in/-.002 in (+0.00 mm/-0.05 mm)
 Bore Tolerance for mounting, +.002 in/-.000 in (+0.05 mm/-0.00 mm)
 Seals - to specify G, K or M seal, replace "Z" in part number with "G", "K" or "M"

"G" seals available in size codes 3 thru 11
 Auxiliary end caps - not available
 For the Selection Guide, Load Ratings and Speed Limits, see the Spherical Roller Bearings Engineering section on pages 15 - 27.
 Note: Dimensions subject to change. Certified dimensions of ordered material furnished on request.

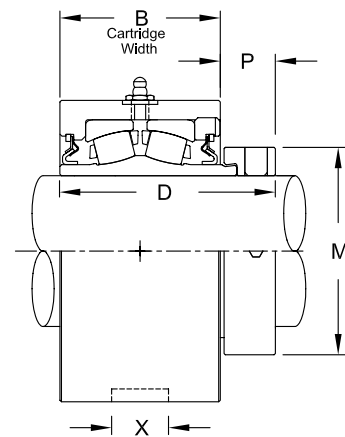
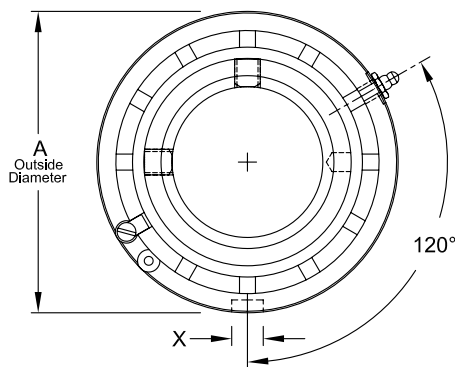
ZMC3000



Photo Shows a Spherical Roller Bearing Cartridge Unit with Cast Iron Housing

Product Features

- Corrosion-resistant powder coating
- Cast iron housing
- Misalignment capabilities - total of 4°
- Broad range of sealing options
- Factory set clearance & lubrication
- Precision ground & superfinished raceways
- Eccentric locking collar
- Field interchangeable seals
- See Features and Benefits for additional info on pages 10 - 13.



Bearing Dimensions

Size Code	Shaft Diameter	Part Number	A Outside Diameter	B Cartridge Length	D	M	P	X Depth	X Length	X Width	Approx. Weight
4	1 ⁷ / ₁₆	ZMC3107	3.4370	2 ³ / ₁₆	2 ⁵⁹ / ₆₄	2 ⁵ / ₁₆	²⁵ / ₃₂	³ / ₁₆	²⁹ / ₃₂	0.531	4.10
5	1 ¹¹ / ₁₆	ZMC3111	3.9370	2 ⁷ / ₁₆	3 ³ / ₁₆	2 ⁵ / ₈	³ / ₄	³ / ₁₆	²⁹ / ₃₂	0.531	5.80
6	1 ¹⁵ / ₁₆	ZMC3115	4.1250	2 ⁷ / ₁₆	3 ⁹ / ₃₂	2 ¹⁵ / ₁₆	²⁷ / ₃₂	³ / ₁₆	²⁹ / ₃₂	0.531	6.00
7	2 ³ / ₁₆	ZMC3203	4.5310	2 ⁹ / ₁₆	3 ¹ / ₂	3 ¹ / ₄	³¹ / ₃₂	³ / ₁₆	²⁹ / ₃₂	0.531	7.80
8	2 ⁷ / ₁₆	ZMC3207	5.0000	2 ⁵ / ₈	3 ²¹ / ₃₂	3 ⁹ / ₁₆	1 ¹ / ₆₄	³ / ₁₆	²⁹ / ₃₂	0.531	9.60
	2 ¹ / ₂	ZMC3208									9.50
9	2 ¹¹ / ₁₆	ZMC3211	5.8750	3 ¹ / ₈	4 ¹³ / ₆₄	4 ¹ / ₁₆	1 ¹ / ₆₄	¹ / ₄	1 ¹ / ₃₂	0.594	16.10
	2 ¹⁵ / ₁₆	ZMC3215									15.10
10	3 ⁷ / ₁₆	ZMC3307	6.7500	3 ⁷ / ₁₆	4 ³⁷ / ₆₄	4 ¹⁵ / ₁₆	1 ⁹ / ₆₄	⁹ / ₃₂	1 ¹ / ₁₆	0.594	21.10
	3 ¹ / ₂	ZMC3308									20.20
11	3 ¹⁵ / ₁₆	ZMC3315	8.1250	4 ¹ / ₈	5 ³ / ₁₆	5 ⁵ / ₈	1 ¹ / ₁₆	⁵ / ₁₆	1 ⁹ / ₃₂	0.781	36.50

Additional Notes

- Please call 1-866-REXNORD for availability
- Lubrication fitting tap size, 1/8" PT
- Bore size = nominal shaft size +.001 in/- .000 in (+0.03 mm/-0.00 mm)
- O.D. tolerance, +.000 in/- .002 in (+0.00 mm/-0.05 mm)
- Bore Tolerance for mounting, +.002 in/- .000 in (+0.05 mm/-0.00 mm)
- Seals - to specify G, K or M seal, replace "Z" in part number with "G", "K" or "M"

Auxiliary end caps - not available

For the Selection Guide, Load Ratings and Speed Limits, see the Spherical Roller Bearings Engineering section on pages 15 - 27.

Note: Dimensions subject to change. Certified dimensions of ordered material furnished on request.

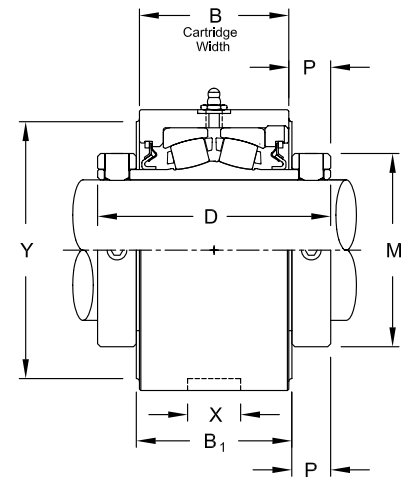
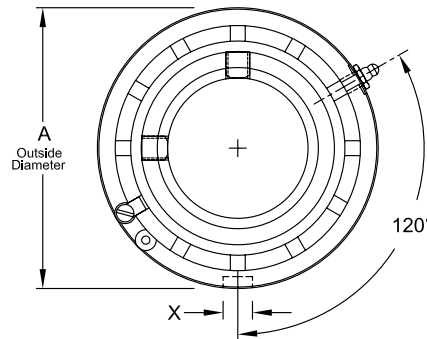
ZMC5000



Photo Shows a Spherical Roller Bearing Cartridge Unit with Cast Iron Housing

Product Features

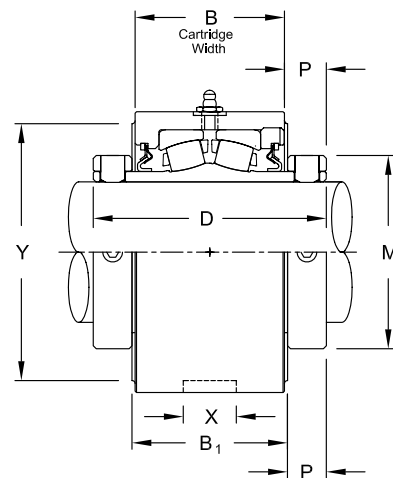
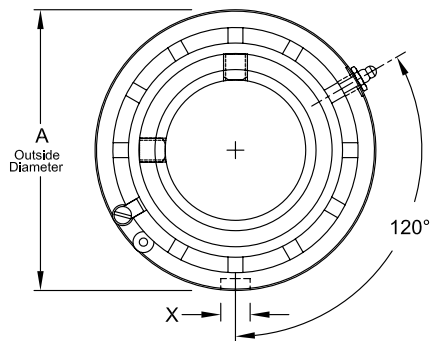
- Corrosion-resistant powder coating
- Cast iron housing
- Misalignment capabilities - total of 4°
- Broad range of sealing options
- Factory set clearance & lubrication
- Precision ground & superfinished raceways
- Two hardened spring locking collars
- Field interchangeable seals
- See Features and Benefits for additional info on pages 10 - 13.



Bearing Dimensions

Size Code	Shaft Diameter	Part Number	A Outside Diameter	B Cartridge Length	B1	D	M	P	X Depth	X Length	X Width	Y	Approx. Weight
4	1 7/16	ZMC5107	3.4370	2 3/16	-	3 9/16	2 5/16	11/16	3/16	29/32	0.531	-	4.30
	35.00	ZMC5035MM	3.4370	2 3/16	-	90.49	58.74	17.46	4.76	23.02	13.490	-	2.00
5	1 1/2	ZMC5108	3.9370	2 7/16	-	3 13/16	2 19/32	11/16	3/16	29/32	0.531	-	6.50
	1 11/16	ZMC5111	3.9370	2 7/16	-	3 13/16	2 19/32	11/16	3/16	29/32	0.531	-	5.90
	40.00	ZMC5040MM	100.0000	61.910	-	96.84	65.88	17.46	4.76	23.02	13.490	-	2.90
	45.00	ZMC5045MM	100.0000	61.910	-	96.84	65.88	17.46	4.76	23.02	13.490	-	2.70
6	1 15/16	ZMC5115	4.1250	2 7/16	-	3 13/16	2 7/8	11/16	3/16	29/32	0.531	-	6.50
	50.00	ZMC5050MM	104.7800	61.910	-	96.84	73.03	17.46	4.76	23.02	13.490	-	2.90
7	2	ZMC5200	4.5310	2 9/16	-	4 1/8	3 1/4	13/16	3/16	29/32	0.531	-	9.50
	2 3/16	ZMC5203	4.5310	2 9/16	-	4 1/8	3 1/4	13/16	3/16	29/32	0.531	-	8.80
	55.00	ZMC5055MM	115.0880	65.090	-	104.78	82.60	20.64	4.76	23.02	13.490	-	4.00
8	2 7/16	ZMC5207	5.0000	2 5/8	-	4 3/8	3 9/16	7/8	3/16	29/32	0.531	-	10.60
	60.00	ZMC5060MM	127.0000	66.680	-	111.13	90.50	22.23	4.76	23.02	13.490	-	5.00
	65.00	ZMC5065MM	127.0000	66.680	-	111.13	90.50	22.23	4.76	23.02	13.490	-	4.80
9	2 1/2	ZMC5208	5.8750	3 1/8	-	4 7/8	4 1/16	7/8	1/4	1 1/32	0.594	-	18.70
	2 11/16	ZMC5211	5.8750	3 1/8	-	4 7/8	4 1/16	7/8	1/4	1 1/32	0.594	-	17.70
	2 15/16	ZMC5215	5.8750	3 1/8	-	4 7/8	4 1/16	7/8	1/4	1 1/32	0.594	-	15.70
	70.00	ZMC5070MM	149.2250	79.380	-	123.83	103.20	22.23	6.35	26.19	15.090	-	8.00
10	75.00	ZMC5075MM	149.2250	79.380	-	123.83	103.20	22.23	6.35	26.19	15.090	-	7.60
	3 3/16	ZMC5303	6.7500	3 7/16	-	5 5/16	4 29/32	15/16	9/32	1 1/16	0.594	-	24.70
	3 7/16	ZMC5307	6.7500	3 7/16	-	5 5/16	4 29/32	15/16	9/32	1 1/16	0.594	-	22.80
	80.00	ZMC5080MM	171.4500	87.310	-	134.94	124.62	23.81	6.35	26.19	15.090	-	11.20
11	85.00	ZMC5085MM	171.4500	87.310	-	134.94	124.62	23.81	6.35	26.19	15.090	-	10.80
	90.00	ZMC5090MM	171.4500	87.310	-	134.94	124.62	23.81	6.35	26.19	15.090	-	10.40
	3 11/16	ZMC5311	8.1250	4 1/8	-	6 1/8	5 5/8	1 1/32	5/16	1 9/32	0.781	-	44.00
	3 15/16	ZMC5315	8.1250	4 1/8	-	6 1/8	5 5/8	1 1/32	5/16	1 9/32	0.781	-	41.50
12	4	ZMC5400	8.1250	4 1/8	-	6 1/8	5 5/8	1 1/32	5/16	1 9/32	0.781	-	41.00
	100.00	ZMC5100MM	206.3750	104.780	-	155.58	142.90	26.19	7.94	32.54	19.840	-	20.00
	4 3/16	ZMC5403Y	8.7500	4 1/4	-	6 1/4	6 3/16	1 1/16	5/16	1 1/2	0.781	-	50.00
	4 7/16	ZMC5407Y	8.7500	4 1/4	-	6 1/4	6 3/16	1 1/16	5/16	1 1/2	0.781	-	47.00
13	4 1/2	ZMC5408Y	8.7500	4 1/4	-	6 1/4	6 3/16	1 1/16	5/16	1 1/2	0.781	-	46.00
	110.00	ZMC5110MM	222.2500	107.950	-	158.75	157.16	26.99	7.94	32.54	19.840	-	22.70
	115.00	ZMC5115MM	222.2500	107.950	-	158.75	157.16	26.99	7.94	32.54	19.840	-	22.00
4 15/16	ZMC5415	10.4370	5 9/16	6	7 7/8	7 1/16	1 5/32	5/16	1 1/2	0.781	7 25/32	95.00	

Continued...



Continued...

Bearing Dimensions

Size Code	Shaft Diameter	Part Number	A Outside Diameter	B Cartridge Length	B1	D	M	P	X Depth	X Length	X Width	Y	Approx. Weight
13	5	ZMC5500	10.4370	5 9/16	6	7 7/8	7 1/16	1 5/32	5/16	1 1/2	0.781	7 25/32	92.00
	125.00	ZMC5125MM	265.1000	141.290	152.40	200.03	179.39	29.37	7.94	32.54	19.840	197.64	43.00
	130.00	ZMC5130MM											42.00
14	5 7/16	ZMC5507	11.5000	5 9/16	5 7/8	8	8 3/16	1 7/32	7/32	1 1/2	0.781	9 9/16	114.00
	140.00	ZMC5140MM	292.1000	141.290	149.23	203.20	207.96	30.96	7.94	32.54	19.840	242.89	51.00
15	5 15/16	ZMC5515	12.2500	5 7/8	6 1/8	8 1/8	8 5/8	1 5/32	7/32	1 1/2	0.781	10 3/8	134.00
	6	ZMC5600											133.00
	150.00	ZMC5150MM	311.1500	149.230	155.58	206.38	219.08	29.37	7.94	32.54	19.840	263.53	
	160.00	ZMC5160MM										59.00	
16	6 7/16	ZMC5607	13.5630	6 3/16	6 1/2	8 3/4	9 23/32	1 9/32	7/32	1 1/2	0.781	10 3/8	180.00
	6 15/16	ZMC5615											167.00
	7	ZMC5700											166.00
	180.00	ZMC5180MM											344.5000

Additional Notes

Please call 1-866-REXNORD for availability
 Metric bore sizes available, see Rex Interchangeability guide
 Lubrication fitting tap size: for size code 4 thru 11, 1/8" PT; for all other size codes, 1/4" PT
 Bore size = nominal shaft size +.001 in/-.000 in (+0.03 mm/-0.00 mm)
 O.D. tolerance, for size code 4 thru 11 +.000 in/-.002 in (+0.00 mm/-0.05 mm); for all other size codes, +.000 in/-.003 in (+0.00 mm/-0.08 mm)
 Bore Tolerance for mounting, +.002 in/-.000 in (+0.05 mm/-0.00 mm)

Seals - to specify G, K or M seal, replace "Z" in part number with "G", "K" or "M"
 "G" seals only available in size codes 4 thru 13
 "K" seals only available in size codes 4 thru 11
 Auxiliary end caps - not available
 For the Selection Guide, Load Ratings and Speed Limits, see the Spherical Roller Bearings Engineering section on pages 15 - 27.
 Note: Dimensions subject to change. Certified dimensions of ordered material furnished on request.

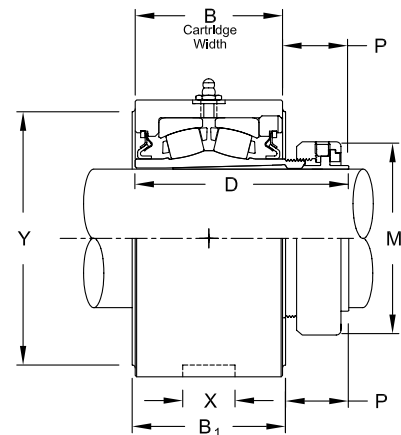
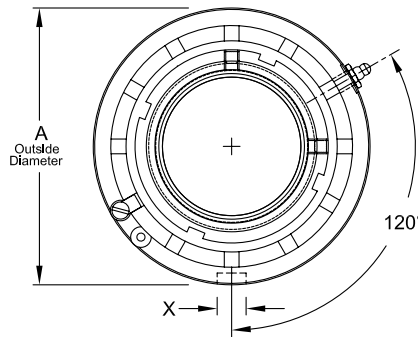
ZMC6000



Photo Shows a Spherical Roller Bearing Cartridge Unit with Cast Iron Housing

Product Features

- Spyglass Optical Strain Sensor (OSS) Technology
- Positive locking system
- Tapered adapter sleeve
- Corrosion-resistant powder coating
- Cast iron housing
- Misalignment capabilities - total of 4°
- Broad range of sealing options
- Factory set clearance & lubrication
- Precision ground & superfinished raceways
- See Features and Benefits for additional info on pages 10 - 13.



Bearing Dimensions

Size Code	Shaft Diameter	Part Number	A Outside Diameter	B Cartridge Length	B1	D	M	P	X Depth	X Length	X Width	Y	Approx. Weight
4	1 7/16	ZMC6107	3.437	2 3/16	-	3 21/64	2 25/64	1 9/64	3/16	29/32	0.531	-	3.90
5	1 11/16	ZMC6111	3.937	2 7/16	-	3 47/64	2 41/64	1 9/32				-	5.60
6	1 15/16	ZMC6115	4.1250	2 7/16	-	3 41/64	2 55/64	1 1/8				-	6.50
	45.00	ZMC6045MM	104.7800	61.910	-	92.47	72.63	28.58	4.76	23.02	13.490	-	2.70
7	2 3/16	ZMC6203	4.5310	2 9/16	-	3 11/16	3 15/64	1 5/32	3/16	29/32	0.531	-	9.50
	55.00	ZMC6055MM	115.0880	65.090	-	93.66	82.15	29.37	4.76	23.02	13.490	-	4.00
8	2 3/8	ZMC6206	5.0000	2 5/8	-	4 1/16	3 19/32	1 27/64	3/16	29/32	0.531	-	10.90
	2 7/16	ZMC6207		-	-	-	-	-	-	-	-	-	10.60
	60.00	ZMC6060MM		127.0000	66.680	-	103.19	91.28	36.12	4.76	23.02	13.490	-
	2 11/16	ZMC6211	5.8750	3 1/8	-	4 17/32	4 3/32	1 25/64	1/4	1 1/32	0.594	-	18.70
9	2 3/4	ZMC6212											17.70
	2 15/16	ZMC6215											15.70
	70.00	ZMC6070MM											8.00
	75.00	ZMC6075MM	149.2250	79.380	-	115.09	103.98	35.32	6.35	26.19	15.090	-	7.60
	3 3/16	ZMC6303	6.7500	3 7/16	-	5 1/32	4 61/64	1 19/32	9/32	1 1/16	0.594	-	24.70
10	3 7/16	ZMC6307											22.80
	80.00	ZMC6080MM											11.20
	85.00	ZMC6085MM											10.80
	3 11/16	ZMC6311	8.1250	4 1/8	-	5 25/32	5 43/64	1 47/64	5/16	1 9/32	0.781	-	44.00
11	3 15/16	ZMC6315											41.50
	90.00	ZMC6090MM											20.00
	100.00	ZMC6100MM	206.3750	104.780	-	146.84	144.07	44.05	7.94	32.54	19.840	-	20.00
	4 3/16	ZMC6403Y	8.7500	4 1/4	-	6 1/4	6 1/16	1 7/8	5/16	1 1/2	0.781	-	50.00
12	4 7/16	ZMC6407Y											47.00
	110.00	ZMC6110MM											22.70
	4 15/16	ZMC6415	10.4370	5 9/16	6	7 15/16	6 61/64	2 1/4	5/16	1 1/2	0.781	7 25/32	95.00
	125.00	ZMC6125MM	265.1000	141.290	152.40	201.61	176.61	57.15	7.94	32.54	19.840	197.640	43.00
14	5 7/16	ZMC6507	11.5000	5 9/16	5 7/8	8 49/64	8 1/64	3 3/64	7/32	1 1/2	0.781	9 9/16	114.00
15	5 15/16	ZMC6515	12.2500	5 7/8	6 1/8	9 19/64	8 21/32	3 7/16	7/32	1 1/2	0.781	10 3/8	134.00
16	6 7/16	ZMC6607	13.5630	6 3/16	6 1/2	10	9 3/4	3 43/64	7/32	1 1/2	0.781	11 3/8	180.00
	6 15/16	ZMC6615											167.00

Additional Notes

- Please call 1-866-REXNORD for availability
- Lubrication fitting tap size: for size code 6 thru 11, 1/8" PT: for all other size codes, 1/4" PT
- Bore size = nominal shaft size +.001 in/-.000 in (+0.03 mm/-0.00 mm)
- O.D. tolerance, for size code 6 thru 11 +.000 in/-.002 in (+0.00 mm/-0.05 mm): for all other size codes, +.000 in/-.003 in (+0.00 mm/-0.08 mm)
- Bore Tolerance for mounting, +.002 in/-.000 in (+0.05 mm/-0.00 mm)
- Seals - to specify K or M seal, replace "Z" in part number with "K" or "M"

- "G" seals only available in size codes 4 thru 13
- "K" seals only available in size codes 4 thru 11
- Auxiliary end caps - not available
- For the Selection Guide, Load Ratings and Speed Limits, see the Spherical Roller Bearings Engineering section on pages 15 - 27.
- Note: Dimensions subject to change. Certified dimensions of ordered material furnished on request.

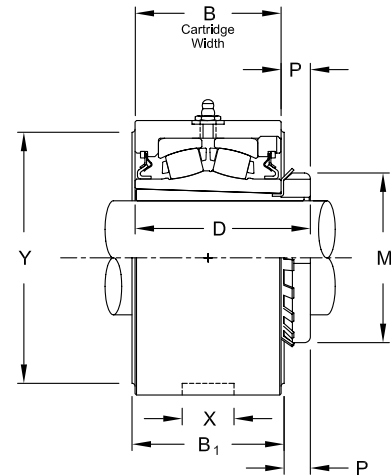
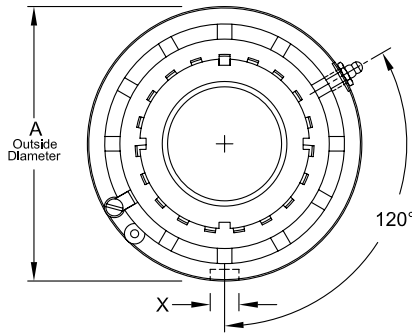
ZMC9000



Photo Shows a Spherical Roller Bearing Cartridge Unit with Cast Iron Housing

Product Features

- Corrosion-resistant powder coating
- Cast iron housing
- Misalignment capabilities - total of 4°
- Broad range of sealing options
- Factory set clearance & lubrication
- Precision ground & superfinished raceways
- Enhanced life mounting style
- Field interchangeable seals
- See Features and Benefits for additional info on pages 10 - 13.



Bearing Dimensions

Size Code	Shaft Diameter	Part Number	A Outside Diameter	B Cartridge Length	B1	D	M	P	X Depth	X Length	X Width	Y	Approx. Weight
7	1 15/16	ZMC9115	4.5310	2 9/16	-	3 5/32	2 31/32	19/32	3/16	29/32	0.531	-	7.60
	2	ZMC9200											7.40
	45.00	ZMC9045MM	115.0880	65.090	-	80.17	75.40	15.08	4.76	23.02	13.490	-	3.50
	50.00	ZMC9050MM											3.40
8	2 3/16	ZMC9203	5.0000	2 5/8	-	3 11/32	3 3/8	23/32	3/16	29/32	0.531	-	9.60
	55.00	ZMC9055MM	127.0000	66.680	-	84.93	85.73	18.26	4.76	23.02	13.490	-	4.30
9	2 7/16	ZMC9207	5.8750	3 1/8	-	3 3/4	3 5/8	5/8	1/4	1 1/32	0.594	-	15.60
	2 1/2	ZMC9208											15.20
10	2 11/16	ZMC9211	6.7500	3 7/16	-	4 1/4	4 13/32	13/16	9/32	1 1/16	0.594	-	23.80
	2 15/16	ZMC9215											22.50
	3	ZMC9300											22.10
	75.00	ZMC9075MM											171.4500
11	3 3/16	ZMC9303	8.1250	4 1/8	-	5	5 3/16	15/16	5/16	1 9/32	0.781	-	41.00
	3 7/16	ZMC9307											39.40
	80.00	ZMC9080MM											206.3750
12	3 11/16	ZMC9311Y	8.7500	4 1/4	-	5 17/32	5 23/32	1 1/32	5/16	1 1/2	0.781	-	48.50
	3 15/16	ZMC9315Y											46.20
	4	ZMC9400Y											45.70
	100.00	ZMC9100MM											222.2500
13	4 3/16	ZMC9403	10.4370	5 9/16	6	6 3/4	6 1/8	1 1/8	5/16	1 1/2	0.781	7 25/32	92.00
	4 7/16	ZMC9407											90.00
14	4 15/16	ZMC9415	11.5000	5 9/16	5 7/8	7 1/16	7 3/32	1 1/8	7/32	1 1/2	0.781	9 9/16	115.00
	5	ZMC9500											108.00
15	5 7/16	ZMC9507	12.2500	5 7/8	6 1/8	7 5/16	8 1/16	1 5/16	7/32	1 1/2	0.781	10 3/8	130.00
	5 15/16	ZMC9515											175.00
	6	ZMC9600											177.00
	6 7/16	ZMC9607											170.00

Additional Notes

- Please call 1-866-REXNORD for availability
- Lubrication fitting tap size: for size code 7 thru 11, 1/8" PT; for all other size codes, 1/4" PT
- Bore size = nominal shaft size +.001 in/-.000 in (+0.03 mm/-0.00 mm)
- O.D. tolerance, for size code 7 thru 11 +.000 in/-.002 in (+0.00 mm/-0.05 mm); for all other size codes, +.000 in/-.003 in (+0.00 mm/-0.08 mm)
- Bore Tolerance for mounting, +.002 in/-.000 in (+0.05 mm/-0.00 mm)
- Seals - to specify G, K or M seal, replace "Z" in part number with "G", "K" or "M"

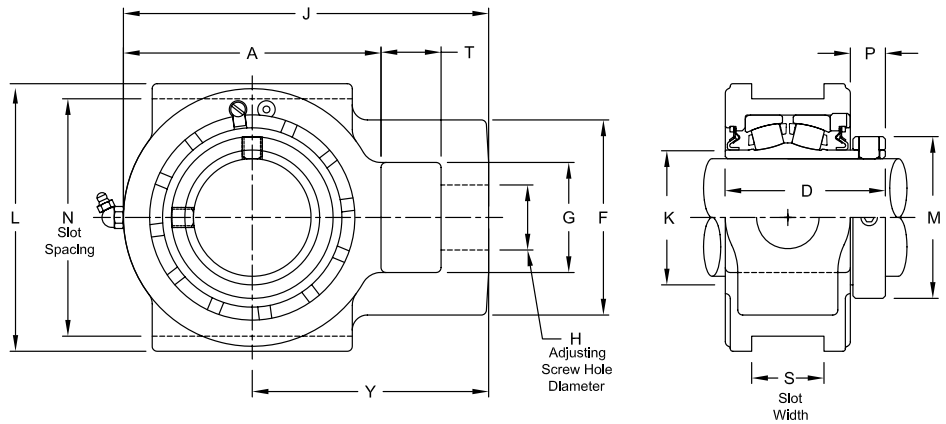
- "G" seals only available in size codes 7 thru 13
- "K" seals only available in size codes 7 thru 11
- Auxiliary end caps - not available
- For the Selection Guide, Load Ratings and Speed Limits, see the Spherical Roller Bearings Engineering section on pages 15 - 27.
- Note: Dimensions subject to change. Certified dimensions of ordered material furnished on request.

ZT2000

Interchange: WSTUS2, WSTUE, TBR, USTU5000, QATU, ETUTRB



Photo Shows a Spherical Roller Bearing Take-up Unit



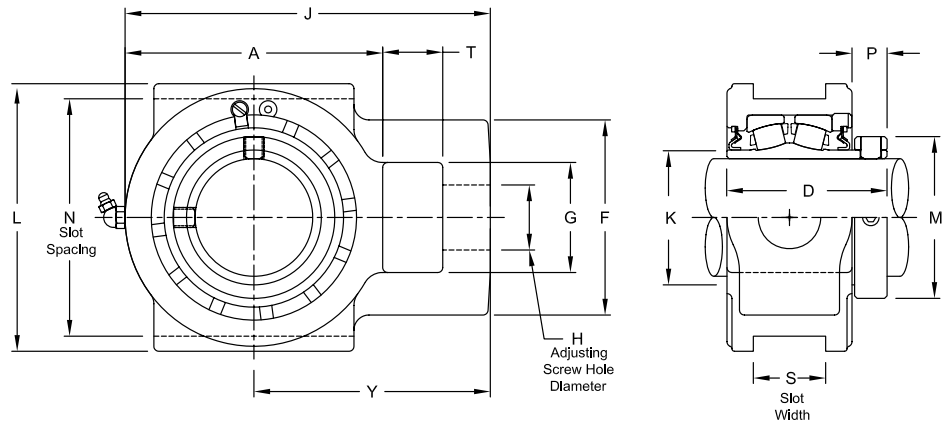
Product Features

- Corrosion-resistant powder coating
- Cast iron housing
- Misalignment capabilities - total of 4°
- Broad range of sealing options
- Factory set clearance & lubrication
- Precision ground & superfinished raceways
- Hardened spring locking collar
- Field interchangeable seals
- See Features and Benefits for additional info on pages 10 - 13.

Bearing Dimensions

Size Code	Shaft Diameter	Part Number	H Adjusting Screw Hole Diameter	N Slot Spacing	S Slot Width	A	D	F	G	J	K	L	M	P	T	Y	Allowable Working Load	Approx. Weight
2	3/4	ZT22012	3/4	3	17/32	3	2 9/16	2	1 1/4	4 1/16	1 5/16	3 5/8	1 3/4	9/16	5/8	2 9/16	4,400	4.00
	15/16	ZT22015																3.90
	1	ZT22100																1.80
	25.00	ZT22025MM	19.05	76.200	13.490	76.20	65.09	50.80	31.75	103.19	33.340	92.08	44.45	14.29	15.88	65.09	1,995	1.80
3	1 1/8	ZT32102	7/8	3 1/2	17/32	3 3/8	2 11/16	2 5/16	1 7/16	4 9/16	1 17/32	4 1/8	1 31/32	9/16	5/8	2 7/8	5,700	5.50
	1 3/16	ZT32103																5.40
	1 1/4	ZT32104																5.30
	30.00	ZT32030MM	22.23	88.900	13.490	85.73	68.26	58.74	36.51	141.29	38.890	104.78	50.00	14.29	15.88	73.03	2,585	2.40
4	1 7/16	ZT42107	7/8	3 1/2	17/32	3 3/4	2 7/8	2 7/16	1 7/16	5 1/16	1 3/4	4 1/8	2 5/16	1 1/16	5/8	3 1/4	7,600	6.40
	1 1/2	ZT42108																6.30
	35.00	ZT42035MM																22.23
5	1 11/16	ZT52111	1 1/8	4	1 1/16	4 1/4	3 1/8	3 5/16	1 3/4	5 15/16	2 1/32	4 3/4	1 19/32	1 1/16	15/16	3 13/16	12,300	9.80
	1 3/4	ZT52112																9.70
	40.00	ZT52040MM																28.58
	45.00	ZT52045MM																4.40
6	1 15/16	ZT62115	1 1/8	4	1 1/16	4 1/2	3 1/8	3 5/16	1 15/16	6 3/16	2 5/16	4 1/2	2 7/8	1 1/16	3/4	3 15/16	12,300	10.10
	2	ZT62200																9.90
	50.00	ZT62050MM																28.58
7	2 3/16	ZT72203	1 3/8	4 1/2	13/16	5	3 5/16	3 7/8	2 1/4	7 1/8	2 5/8	5 1/4	3 1/4	13/16	1 1/4	4 5/8	13,500	13.60
	2 1/4	ZT72204																13.40
	55.00	ZT72055MM																34.93
8	2 3/8	ZT82206	1 3/8	5 1/8	1 1/16	5 1/2	3 1/2	4 1/4	2 1/4	7 13/16	2 29/32	5 7/8	3 9/16	7/8	1 1/4	5 1/16	20,900	18.30
	2 7/16	ZT82207																18.20
	2 1/2	ZT82208																17.90
	60.00	ZT82060MM																34.93
	65.00	ZT82065MM																8.10
9	2 11/16	ZT92211	1 5/8	5 15/16	1 13/16	6 7/16	4	4 7/8	2 3/4	9 1/8	3 3/8	6 11/16	4 1/16	7/8	1 1/2	5 15/16	26,800	28.80
	2 3/4	ZT92212																28.40
	2 15/16	ZT92215																27.60
	3	ZT92300																27.00
	70.00	ZT92070MM																41.28
	75.00	ZT92075MM																12.50
10	3 3/16	ZT102303	1 7/8	6 13/16	1 13/16	7 3/8	4 3/8	5 3/8	2 7/8	10	3 31/32	7 13/16	4 29/32	15/16	1 5/8	6 5/16	27,300	42.50
	3 7/16	ZT102307																40.50

Continued...



Continued...

Bearing Dimensions

Size Code	Shaft Diameter	Part Number	H Adjusting Screw Hole Diameter	N Slot Spacing	S Slot Width	A	D	F	G	J	K	L	M	P	T	Y	Allowable Working Load	Approx. Weight
10	3 1/2	ZT102308	1 7/8	6 13/16	1 13/16	7 3/8	4 3/8	5 3/8	2 7/8	10	3 31/32	7 13/16	4 29/32	15/16	1 5/8	6 5/16	27,300	40.00
	80.00	ZT102080MM															19.30	
	85.00	ZT102085MM	47.63	173.040	46.040	187.33	111.13	136.53	73.03	254.00	100.810	198.44	124.62	23.81	41.28	160.34	12,380	18.40
	90.00	ZT102090MM															18.10	
11	3 11/16	ZT112311																71.00
	3 15/16	ZT112315	2 1/8	8 5/8	2 1/16	8 7/8	5 1/16	5 3/8	3 3/8	12 1/8	4 9/16	9 7/16	5 5/8	1 1/32	2 1/8	7 11/16	45,400	68.00
	4	ZT112400																67.00
	100.00	ZT112100MM	53.98	219.080	52.390	225.43	128.59	136.53	85.73	307.98	115.890	239.71	142.90	26.19	53.98	195.26	20,600	30.90

Additional Notes

- Please call 1-866-REXNORD for availability
- Metric bore sizes available, see Rex Interchangeability guide
- Lubrication fitting tap size, 1/8" PT
- Bore size = nominal shaft size +.001 in/-.000 in (+0.03 mm/-0.00 mm)
- Take-up slot spacing & width tolerance, +.005 in/-.015 in (+0.13 mm/-0.38 mm)
- Seals - to specify G, K or M seal, replace "Z" in part number with "G", "K" or "M"
- Auxiliary end caps - available in all size codes except for size codes 2 & 3

- "G" seals only available in size codes 3 thru 11
- Allowable working load is 2/3 yield strength
- For the Selection Guide, Load Ratings and Speed Limits, see the Spherical Roller Bearings Engineering section on pages 15 - 27.
- Note: Dimensions subject to change. Certified dimensions of ordered material furnished on request.

ZT3000

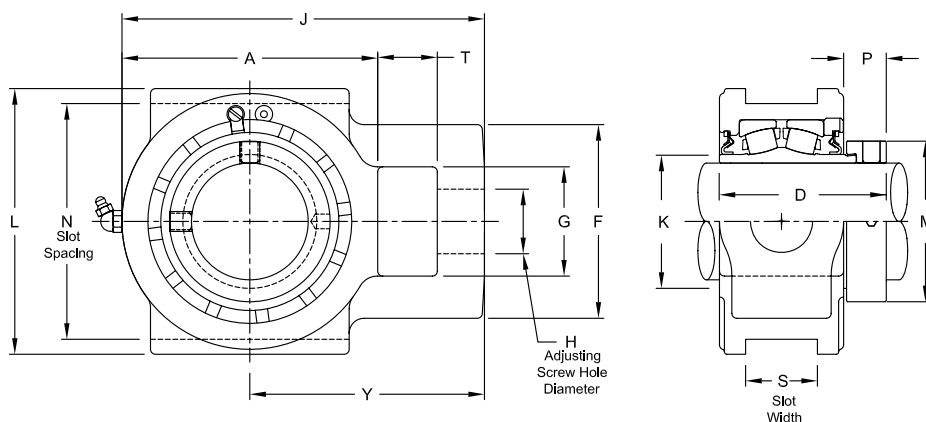
Interchange: QMTU



Photo Shows a Spherical Roller Bearing Take-up Unit

Product Features

- Corrosion-resistant powder coating
- Cast iron housing
- Misalignment capabilities - total of 4°
- Broad range of sealing options
- Factory set clearance & lubrication
- Precision ground & superfinished raceways
- Hardened eccentric locking collar
- Field interchangeable seals
- See Features and Benefits for additional info on pages 10 - 13.



Bearing Dimensions

Size Code	Shaft Diameter	Part Number	H Adjusting Screw Hole Diameter	N Slot Spacing	S Slot Width	A	D	F	G	J	K	L	M	P	T	Y	Allowable Working Load (2/3 Yield Strength)	Approx. Weight
4	1 7/16	ZT43107	7/8	3 1/2	17/32	3 3/4	2 59/64	2 7/16	1 7/16	5 1/16	1 3/4	4 1/8	2 5/16	25/32	5/8	3 1/4	7,600	6.60
5	1 11/16	ZT53111	1 1/8	4	11/16	4 1/4	3 3/16	3 5/16	1 15/16	5 15/16	2 1/32	4 3/4	2 5/8	3/4	3/4	3 13/16	12,300	10.00
6	1 15/16	ZT63115	1 1/8	4	11/16	4 1/2	3 9/32	3 5/16	1 15/16	6 3/16	2 5/16	4 1/2	2 3/4	27/32	3/4	3 15/16	12,300	13.50
7	2 3/16	ZT73203	1 3/8	4 1/2	13/16	5	3 1/2	3 7/8	2 1/4	7 1/8	2 5/8	5 1/4	3 1/4	31/32	1 1/4	4 5/8	13,500	13.90
8	2 7/16	ZT83207	1 3/8	5 1/8	1 1/16	5 1/2	3 21/32	4 1/4	2 1/4	7 13/16	2 29/32	5 7/8	3 9/16	1 1/64	1 1/4	5 1/16	20,900	18.40
	2 1/2	ZT83208																18.30
9	2 11/16	ZT93211	1 5/8	5 15/16	1 13/16	6 7/16	4 13/64	4 7/8	2 3/4	9 1/8	3 3/8	6 11/16	4 1/16	1 1/64	1 1/2	5 15/16	26,800	29.00
	2 15/16	ZT93215																28.00
10	3 7/16	ZT103307	1 7/8	6 13/16	1 13/16	7 3/8	4 37/64	5 3/8	2 7/8	10	3 31/32	7 13/16	4 15/16	1 9/64	1 5/8	6 5/16	27,300	41.10
	3 1/2	ZT103308																40.90
11	3 15/16	ZT113315	2 1/8	8 5/8	2 1/16	8 7/8	5 3/16	5 3/8	3 3/8	12 3/8	4 9/16	9 7/16	5 5/8	1 1/16	2 1/8	7 11/16	45,400	68.00

Additional Notes

- Please call 1-866-REXNORD for availability
- Lubrication fitting tap size, 1/8" PT
- Bore size = nominal shaft size +.001 in/-.000 in (+0.03 mm/-0.00 mm)
- Take-up slot spacing & width tolerance, +.005 in/-.015 in (+0.13 mm/-0.38 mm)
- Seals - to specify G, K or M seal, replace "Z" in part number with "G", "K" or "M"
- Auxiliary end caps - available in all size codes
- Allowable working load is 2/3 yield strength

For the Selection Guide, Load Ratings and Speed Limits, see the Spherical Roller Bearings Engineering section on pages 15 - 27.

Note: Dimensions subject to change. Certified dimensions of ordered material furnished on request.

ZT5000

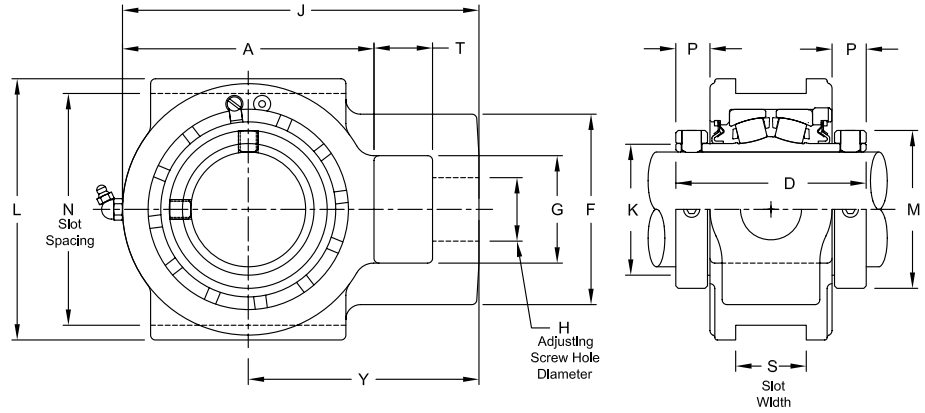
Interchange: QAATU



Photo Shows a Spherical Roller Bearing Take-up Unit

Product Features

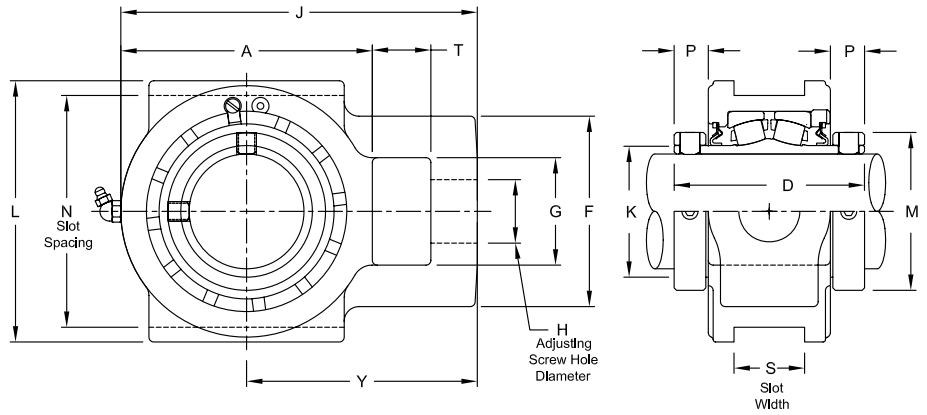
- Corrosion-resistant powder coating
- Cast iron housing
- Misalignment capabilities - total of 4°
- Broad range of sealing options
- Factory set clearance & lubrication
- Precision ground & superfinished raceways
- Two hardened spring locking collars
- Field interchangeable seals
- See Features and Benefits for additional info on pages 10 - 13.



Bearing Dimensions

Size Code	Shaft Diameter	Part Number	H Adjusting Screw Hole Diameter	N Slot Spacing	S Slot Width	A	D	F	G	J	K	L	M	P	T	Y	Allowable Working Load	Approx. Weight
4	1 7/16	ZT45107	7/8	3 1/2	17/32	3 3/4	3 9/16	2 7/16	1 7/16	5 1/16	1 3/4	4 1/8	2 5/16	11/16	5/8	3 1/4	7,600	6.80
	35.00	ZT45035MM	22.23	88.900	13.490	95.25	90.49	61.91	36.51	128.59	44.450	104.78	58.74	17.46	15.88	82.55	3,447	3.10
5	1 1/2	ZT55108	1 1/8	4	11/16	4 1/4	3 13/16	3 5/16	1 3/4	5 15/16	2 1/32	4 3/4	2 19/32	11/16	15/16	3 13/16	12,300	10.90
	1 11/16	ZT55111																10.20
	40.00	ZT55040MM	28.58	101.600	17.460	107.95	96.84	84.14	44.45	150.81	51.590	120.65	65.88	17.46	23.81	96.84	5,580	4.90
	45.00	ZT55045MM	4.60															
6	1 15/16	ZT65115	1 1/8	4	11/16	4 1/2	3 13/16	3 5/16	1 15/16	6 3/16	2 5/16	4 1/2	2 7/8	11/16	3/4	3 15/16	12,300	10.80
	50.00	ZT65050MM	28.58	101.600	17.460	114.30	96.84	84.14	49.21	157.16	58.740	114.30	73.03	17.46	19.05	100.01	5,580	4.90
7	2	ZT75200	1 3/8	4 1/2	13/16	5	4 1/8	3 7/8	2 1/4	7 1/8	2 5/8	5 1/4	3 1/4	13/16	1 1/4	4 5/8	13,500	15.20
	2 3/16	ZT75203																14.50
	55.00	ZT75055MM	34.93	114.300	20.640	127.00	104.78	98.43	57.15	180.98	66.680	133.35	82.60	20.64	31.75	117.48	6,120	6.60
8	2 7/16	ZT85207	1 3/8	5 1/8	1 1/16	5 1/2	4 3/8	4 1/4	2 1/4	7 13/16	2 29/32	5 7/8	3 9/16	7/8	1 1/4	5 1/16	20,900	19.40
	60.00	ZT85060MM	34.93	130.180	26.990	139.70	111.13	107.95	57.15	198.44	73.810	149.23	90.50	22.23	31.75	128.59	9,480	8.80
	65.00	ZT85065MM	8.50															
9	2 1/2	ZT95208	1 5/8	5 15/16	1 13/16	6 7/16	4 7/8	4 7/8	2 3/4	9 1/8	3 3/8	6 11/16	4 1/16	7/8	1 1/2	5 15/16	26,800	31.50
	2 11/16	ZT95211																30.10
	2 15/16	ZT95215																28.80
	70.00	ZT95070MM																13.60
	75.00	ZT95075MM	41.28	150.810	46.040	163.51	123.83	123.83	69.85	231.78	85.730	169.86	103.20	22.23	38.10	150.81	12,150	13.00
10	3 3/16	ZT105303	1 7/8	6 13/16	1 13/16	7 3/8	5 5/16	5 3/8	2 7/8	10	3 31/32	7 13/16	4 29/32	15/16	1 5/8	6 5/16	27,300	44.00
	3 7/16	ZT105307																42.00
	80.00	ZT105080MM																20.00
	85.00	ZT105085MM																19.00
	90.00	ZT105090MM	47.63	173.040	46.040	187.33	134.94	136.53	73.03	254.00	100.810	198.44	124.62	23.81	41.28	160.34	12,380	18.00
11	3 11/16	ZT115311	2 1/8	8 5/8	2 1/16	8 7/8	6 1/8	5 3/8	3 3/8	12 1/8	4 9/16	9 7/16	5 5/8	1 1/32	2 1/8	7 11/16	45,400	75.00
	3 15/16	ZT115315																72.00
	4	ZT115400																71.00
	100.00	ZT115100MM	53.98	219.080	52.390	225.43	155.58	136.53	85.73	307.98	115.890	239.71	142.90	26.19	53.98	195.26	20,600	33.00
12	4 3/16	ZT125403Y	2 1/8	9 1/2	2 1/16	9 13/16	6 1/4	6 3/8	3 3/8	13 7/16	5 1/32	10 3/8	6 3/16	1 1/16	2 1/8	8 11/16	53,700	94.00
	4 7/16	ZT125407Y																91.00
	4 1/2	ZT125408Y																90.00
	110.00	ZT125110MM																41.00
	115.00	ZT125115MM	53.98	241.300	52.390	249.24	158.75	161.93	85.73	341.31	127.790	263.53	157.16	26.99	53.98	220.66	24,350	40.00
13	4 15/16	ZT135415	2 3/8	10 1/4	2 1/16	10 7/8	7 7/8	6 1/4	3 3/4	14 7/8	5 3/4	11 1/4	7 1/16	1 5/32	2 1/2	9 7/16	68,000	130.00

Continued...



Continued...

Bearing Dimensions

Size Code	Shaft Diameter	Part Number	H Adjusting Screw Hole Diameter	N Slot Spacing	S Slot Width	A	D	F	G	J	K	L	M	P	T	Y	Allowable Working Load	Approx. Weight
13	5	ZT135500	2 3/8	10 1/4	2 1/16	10 7/8	7 7/8	6 1/4	3 3/4	14 7/8	5 3/4	11 1/4	7 1/16	1 5/32	2 1/2	9 7/16	68,000	127.00
	125.00	ZT135125MM	60.33	260.350	52.390	276.23	200.03	158.75	95.25	377.83	146.050	285.75	179.39	29.37	63.50	239.71	30,800	59.00
	130.00	ZT135130MM																57.00
14	5 7/16	ZT145507	3 1/8	14 1/8	2 9/16	15 3/8	8	8	5	20 5/8	6 1/2	16	8 3/16	1 7/32	3 1/2	12 7/16	140,900	417.00
	140.00	ZT145140MM	79.38	358.780	65.090	390.53	203.20	203.20	127.00	523.88	165.100	406.40	207.96	30.96	88.90	315.91	63,900	189.00
15	5 15/16	ZT155515	3 1/8	14 1/8	2 9/16	15 3/8	8 1/8	8	5	20 5/8	7 13/64	16	8 5/8	1 5/32	3 1/2	12 15/16	140,900	426.00
	6	ZT155600																424.00
	150.00	ZT155150MM	79.38	358.780	65.090	390.53	206.38	203.20	127.00	523.88	182.960	406.40	219.08	29.37	88.90	328.61	63,900	193.00
	160.00	ZT155160MM																192.00
16	6 7/16	ZT165607	3 1/8	14 1/8	2 9/16	15 3/8	8 3/4	8	5	20 5/8	8 3/64	16	9 23/32	1 9/32	3 1/2	12 15/16	165,300	433.00
	6 15/16	ZT165615																428.00
	7	ZT165700																426.00
	180.00	ZT165180MM																79.38

Additional Notes

Please call 1-866-REXNORD for availability
 Metric bore sizes available, see Rex Interchangeability guide
 Lubrication fitting tap size: for size code 4 thru 11, 1/8" PT: for all other size codes, 1/4" PT
 Bore size = nominal shaft size +.001 in/-.000 in (+0.03 mm/-0.00 mm)
 Take-up slot spacing & width tolerance, +.005 in/-.015 in (+0.13 mm/-0.38 mm)
 Seals - to specify G, K or M seal, replace "Z" in part number with "G", "K" or "M"
 "K" seals only available in size codes 4 thru 11

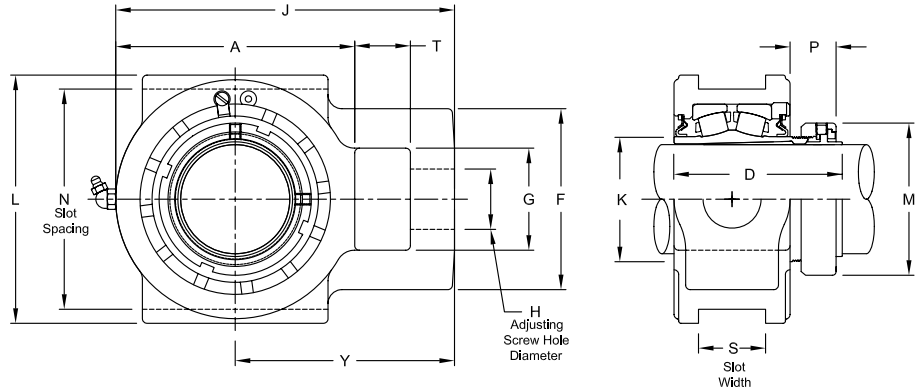
"G" seals only available in size codes 4 thru 13
 Auxiliary end caps - available in all size codes
 Allowable working load is 2/3 yield strength
 For the Selection Guide, Load Ratings and Speed Limits, see the Spherical Roller Bearings Engineering section on pages 15 - 27.
 Note: Dimensions subject to change. Certified dimensions of ordered material furnished on request.

ZT6000

Interchange: WSTUIP, TBR-N, USTU5000A, QVVTU



Photo Shows a Spherical Roller Bearing Take-up Unit



Product Features

- Spyglass Optical Strain Sensor (OSS) Technology
- Positive locking system
- Tapered adapter sleeve
- Corrosion-resistant powder coating
- Cast iron housing
- Misalignment capabilities - total of 4°
- Broad range of sealing options
- Factory set clearance & lubrication
- Precision ground & superfinished raceways
- See Features and Benefits for additional info on pages 10 - 13.

Bearing Dimensions

Size Code	Shaft Diameter	Part Number	H Adjusting Screw Hole Diameter	N Slot Spacing	S Slot Width	A	D	F	G	J	K	L	M	P	T	Y	Allowable Working Load	Approx. Weight															
4	1 7/16	ZT46107	7/8	3 1/2	17/32	3 3/4	3 21/64	2 7/16	1 7/16	5 1/16	1 3/4	4 1/8	2 25/64	1 9/64	5/8	3 1/4	7,600	6.40															
5	1 11/16	ZT56111	1 1/8	4	11/16	4 1/4	3 47/64	3 5/16	1 3/4	5 1/16	2 1/32	4 3/4	2 41/64	1 9/32	15/16	3 13/16	12,300	9.80															
6	1 15/16	ZT66115	1 1/8	4	11/16	4 1/2	3 41/64	3 5/16	1 15/16	6 3/16	2 5/16	4 1/2	2 55/64	1 1/8	3/4	3 15/16	12,300	10.80															
	45.00	ZT66045MM	28.58	101.600	17.460	114.30	92.47	84.14	49.21	157.16	58.740	114.30	72.63	28.58	19.05	100.01	5,580	4.60															
7	2 3/16	ZT76203	1 3/8	4 1/2	13/16	5	3 11/16	3 7/8	2 1/4	7 1/8	2 5/8	5 1/4	3 15/64	1 5/32	1 1/4	4 5/8	13,500	15.20															
	55.00	ZT76055MM	34.93	114.300	20.640	127.00	93.66	98.43	57.15	180.98	66.680	133.35	82.15	29.37	31.75	117.48	6,120	6.60															
8	2 3/8	ZT86206	1 3/8	5 1/8	1 1/16	5 1/2	4 1/16	4 1/4	2 1/4	7 13/16	2 29/32	5 7/8	3 19/32	1 27/64	1 1/4	5 1/16	20,900	19.90															
	2 7/16	ZT86207																19.40															
9	60.00	ZT86060MM	34.93	130.180	26.990	139.70	103.19	107.95	57.15	198.44	73.810	149.23	91.28	36.12	31.75	128.59	9,480	8.80															
	2 11/16	ZT96211	1 5/8	5 15/16	1 13/16	6 7/16	4 17/32	4 7/8	2 3/4	9 1/8	3 3/8	6 11/16	4 3/32	1 25/64	1 1/2	5 15/16	26,800	31.50															
	2 3/4	ZT96212																30.10															
	2 15/16	ZT96215																28.80															
70.00	ZT96070MM	41.28																150.810	46.040	163.51	115.09	123.83	69.85	231.78	85.730	169.86	103.98	35.32	38.10	150.81	12,150	13.60	
75.00	ZT96075MM																	13.00															
10	3 3/16	ZT106303	1 7/8	6 13/16	1 13/16	7 3/8	5 1/32	5 3/8	2 7/8	10	3 31/32	7 13/16	4 61/64	1 19/32	1 5/8	6 5/16	27,300	44.00															
	3 7/16	ZT106307																42.00															
	80.00	ZT106080MM																47.63	173.040	46.040	187.33	127.79	136.53	73.03	254.00	100.810	198.44	125.81	40.48	41.28	160.34	12,380	20.00
	85.00	ZT106085MM																															
11	3 11/16	ZT116311	2 1/8	8 5/8	2 1/16	8 7/8	5 25/32	5 3/8	3 3/8	12 1/8	4 9/16	9 7/16	5 43/64	1 47/64	2 1/8	7 11/16	45,400	75.00															
	3 15/16	ZT116315																72.00															
	90.00	ZT116090MM																53.98	219.080	52.390	225.43	146.84	136.53	85.73	307.98	115.890	239.71	144.07	44.05	53.98	195.26	20,600	33.00
	100.00	ZT116100MM																															
12	4 3/16	ZT126403Y	2 1/8	9 1/2	2 1/16	9 13/16	6 1/4	6 3/8	3 3/8	13 7/16	5 1/32	10 3/8	6 1/16	1 7/8	2 1/8	8 11/16	53,700	94.00															
	4 7/16	ZT126407Y																91.00															
	110.00	ZT126110MM																53.98	241.300	52.390	249.24	158.75	161.93	85.73	341.31	127.790	263.53	153.99	47.63	53.98	220.66	24,350	41.00
13	4 15/16	ZT136415	2 3/8	10 1/4	2 1/16	10 7/8	7 15/16	6 1/4	3 3/4	14 7/8	5 3/4	11 1/4	6 61/64	2 1/4	2 1/2	9 7/16	68,000	130.00															
	125.00	ZT136125MM	60.33	260.350	52.390	276.23	201.61	158.75	95.25	377.83	146.050	285.75	176.61	57.15	63.50	239.71	30,800	59.00															
14	5 7/16	ZT146507	3 1/8	14 1/8	2 9/16	15 3/8	8 49/64	8	5	20 5/8	6 1/2	16	8 1/64	3 3/64	3 1/2	12 7/16	140,900	417.00															
15	5 15/16	ZT156515	3 1/8	14 1/8	2 9/16	15 3/8	9 19/64	8	5	20 5/8	7 13/64	16	8 21/32	3 7/16	3 1/2	12 15/16	140,900	426.00															
16	6 7/16	ZT166607	3 1/8	14 1/8	2 9/16	15 3/8	10	8	5	20 5/8	8 3/64	16	9 3/4	3 43/64	3 1/2	12 15/16	165,300	433.00															
	6 15/16	ZT166615																428.00															

Additional Notes

- Please call 1-866-REXNORD for availability
- Lubrication fitting tap size: for size code 4 thru 11, 1/8" PT; for all other size codes, 1/4" PT
- Take-up slot spacing & width tolerance, +.005 in/-.015 in (**+0.13 mm/-0.38 mm**)
- Seals - to specify G, K or M seal, replace "Z" in part number with "G", "K" or "M"
- "G" seal only available in size codes 4 thru 13
- "K" seals only available in size codes 4 thru 11

- Auxiliary end caps - available in all size codes
- Allowable working load is 2/3 yield strength
- For the Selection Guide, Load Ratings and Speed Limits, see the Spherical Roller Bearings Engineering section on pages 15 - 27.
- Note: Dimensions subject to change. Certified dimensions of ordered material furnished on request.

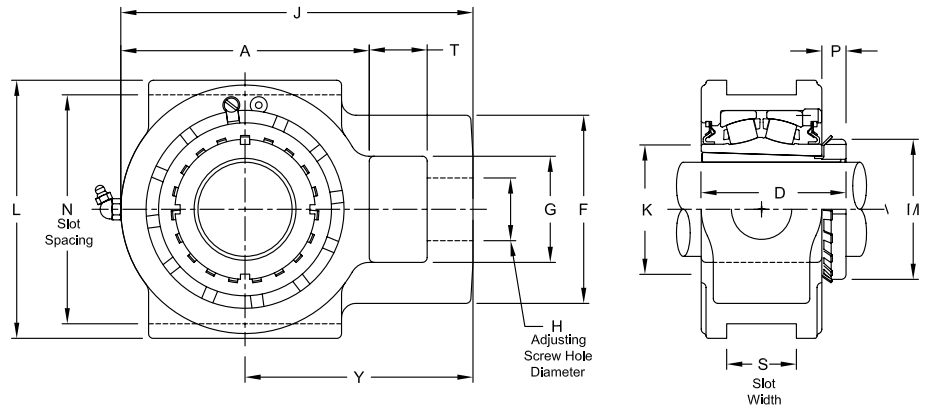
ZT9000



Photo Shows a Spherical Roller Bearing Take-up Unit

Product Features

- Corrosion-resistant powder coating
- Cast iron housing
- Misalignment capabilities - total of 4°
- Broad range of sealing options
- Factory set clearance & lubrication
- Precision ground & superfinished raceways
- Enhanced life mounting style
- Field interchangeable seals
- See Features and Benefits for additional info on pages 10 - 13.



Bearing Dimensions

Size Code	Shaft Diameter	Part Number	H Adjusting Screw Hole Diameter	N Slot Spacing	S Slot Width	A	D	F	G	J	K	L	M	P	T	Y	Allowable Working Load	Approx. Weight
7	1 15/16	ZT79115	1 3/8	4 1/2	13/16	5	3 5/32	3 7/8	2 1/4	7 1/8	2 5/8	5 1/4	2 31/32	19/32	1 1/4	4 5/8	13,500	13.70
	2	ZT79200																13.60
	45.00	ZT79045MM	34.93	114.300	20.640	127.00	80.17	98.43	57.15	180.98	66.680	133.35	75.40	15.08	31.75	117.48	6,120	6.30
	50.00	ZT79050MM																6.10
8	2 3/16	ZT89203	1 3/8	5 1/8	1 1/16	5 1/2	3 11/32	4 1/4	2 1/4	7 13/16	2 29/32	5 7/8	3 3/8	23/32	1 1/4	5 1/16	20,900	18.70
	55.00	ZT89055MM	34.93	130.180	26.990	139.70	84.93	107.95	57.15	198.44	73.810	149.23	85.73	18.26	31.75	128.59	9,480	8.50
9	2 7/16	ZT99207	1 5/8	5 15/16	1 13/16	6 7/16	3 3/4	4 7/8	2 3/4	9 1/8	3 3/8	6 11/16	3 5/8	5/8	1 1/2	5 15/16	26,800	29.10
	2 1/2	ZT99208																28.70
10	2 11/16	ZT109211	1 7/8	6 13/16	1 13/16	7 3/8	4 1/4	5 3/8	2 7/8	10	3 31/32	7 13/16	4 13/32	13/16	1 5/8	6 5/16	27,300	42.60
	2 15/16	ZT109215																41.40
	3	ZT109300																40.70
	75.00	ZT109075MM	47.63	173.040	46.040	187.33	107.95	136.53	73.03	307.98	115.890	239.71	131.76	23.81	53.98	195.26	20,600	34.00
11	3 3/16	ZT119303	2 1/8	8 5/8	2 1/16	8 7/8	5	5 3/8	3 3/8	12 1/8	4 9/16	9 7/16	5 3/16	15/16	2 1/8	7 11/16	45,400	75.50
	3 7/16	ZT119307																73.50
	80.00	ZT119080MM	53.98	219.080	52.390	225.43	127.00	136.53	85.73	307.98	115.890	239.71	131.76	23.81	53.98	195.26	20,600	34.00
12	3 11/16	ZT129311Y	2 1/8	9 1/2	2 1/16	9 13/16	5 17/32	6 3/8	3 3/8	13 7/16	5 1/32	10 3/8	5 23/32	1 1/32	2 1/8	8 11/16	53,700	91.20
	3 15/16	ZT129315Y																88.90
	4	ZT129400Y																88.40
	100.00	ZT129100MM	53.98	241.300	52.390	249.24	140.49	161.93	85.73	341.31	127.790	263.53	145.26	26.19	53.98	220.66	24,350	41.30
13	4 3/16	ZT139403	2 3/8	10 1/4	2 1/16	10 7/8	6 3/4	6 1/4	3 3/4	14 7/8	5 3/4	11 1/4	6 1/8	1 1/8	2 1/2	9 7/16	68,000	130.00
	4 7/16	ZT139407																128.00
14	4 15/16	ZT149415	3 1/8	14 1/8	2 9/16	15 3/8	7 1/16	8	5	20 5/8	6 1/2	16	7 3/32	1 1/8	3 1/2	12 7/16	140,900	411.00
	5	ZT149500																410.00
15	5 7/16	ZT159507	3 1/8	14 1/8	2 9/16	15 3/8	7 5/16	8	5	20 5/8	7 13/64	16	8 1/16	1 5/16	3 1/2	12 15/16	140,900	421.00
	5 15/16	ZT169515																428.00
	16	6	ZT169600	3 1/8	14 1/8	2 9/16	15 3/8	7 3/4	8	5	20 5/8	8 3/64	16	9 1/16	1 11/16	3 1/2	12 15/16	165,300
6 7/16		ZT169607	420.00															

Additional Notes

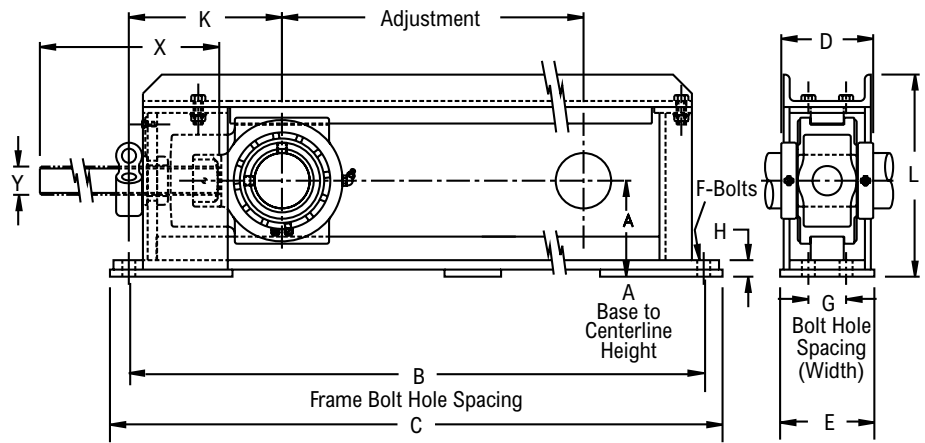
- Please call 1-866-REXNORD for availability
- Lubrication fitting tap size: for size code 7 thru 11, 1/8" PT; for all other size codes, 1/4" PT
- Take-up slot spacing & width tolerance, +.005 in/-0.015 in (+0.13 mm/-0.38 mm)
- Seals - to specify G, K or M seal, replace "Z" in part number with "G", "K" or "M"
- "G" seals only available in size codes 7 thru 13
- "K" seals only available in size codes 7 thru 11
- Auxiliary end caps - available in all size codes

- Allowable working load is 2/3 yield strength
- For the Selection Guide, Load Ratings and Speed Limits, see the Spherical Roller Bearings Engineering section on pages 15 - 27.
- Note: Dimensions subject to change. Certified dimensions of ordered material furnished on request.

ZHT5000



Photo Shows a Center Pull Take-up Frame with Spherical Roller Bearing Take-up Unit



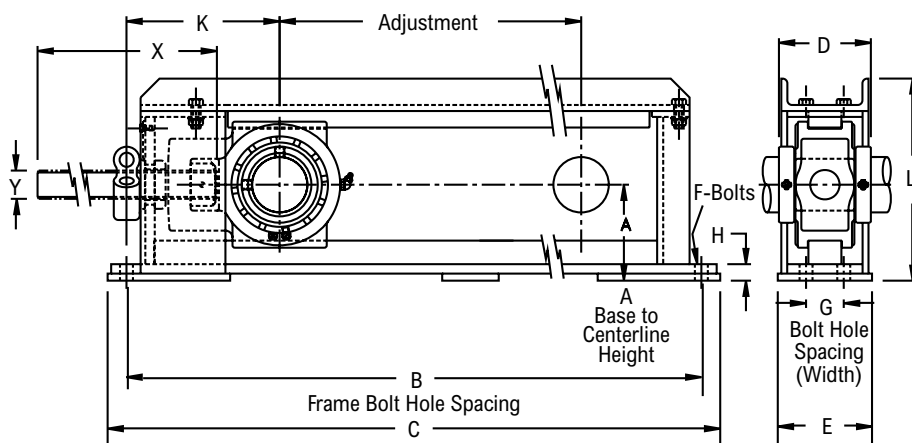
Product Features

- Center pull type frame
- Corrosion-resistant powder coating
- Cast iron housing
- Misalignment capabilities - total of 3°
- Broad range of sealing options
- Factory set clearance & lubrication
- Precision ground & superfinished raceways
- Field interchangeable seals
- See Features and Benefits for additional info on pages 10 - 13.

Bearing Dimensions

Size Code	Shaft Diameter	Complete Take-up Assembly	Travel Length	A Base to Centerline Height	B Frame Bolt Hole Spacing	G Bolt Hole Spacing (Width)	C	D	E	F	H	K	L	X	Y	Adjust.	Allowable Working Load	Approx. Weight		
2-Bolt																				
5	1 1/2	ZHT55108	12	3 15/16	27 1/2	-	29 1/2	3 13/16	4	5/8	7/8	6 9/16	8 7/16	19 1/2	15	12,300	59	69		
			18				35 1/2							25 1/2					21	
	24	41 1/2	31 1/2				27							1-8NC					33	77
	30	47 1/2	37 1/2				33							86						
	36	53 1/2	43 1/2	39	95															
	1 11/16	ZHT55111	304.80	100.01	698.50	-	749.30	96.80	101.60	15.88	22.22	166.70	214.31	495.30	1-8NC	381.00	54710.40	267.57		
457.20			850.90				647.70							533.40					312.92	
609.60	1003.30	800.10	685.80				349.20													
762.00	1155.70	952.50	838.20				390.01													
	914.40	1308.10	1104.90	990.60	430.83															
6	1 15/16	ZHT65115	12	3 15/16	27 1/2	-	29 1/2	3 13/16	4	5/8	7/8	6 9/16	8 7/16	19 1/2	15	12,300	59	69		
			18				35 1/2							25 1/2					21	
	24	41 1/2	31 1/2				27							1-8NC					33	77
	30	47 1/2	37 1/2				33							86						
	36	53 1/2	43 1/2	39	95															
	50 MM	ZHT65050MM	304.80	100.01	698.50	-	749.30	96.80	101.60	15.88	22.22	166.70	214.31	495.30	1-8NC	381.00	54710.40	267.57		
457.20			850.90				647.70							533.40					312.92	
609.60	1003.30	800.10	685.80				349.20													
762.00	1155.70	952.50	838.20				390.01													
	914.40	1308.10	1104.90	990.60	430.83															
7	2	ZHT75200	12	4 7/16	27 1/2	-	29 1/2	4 1/8	4	5/8	1 3/16	6 13/16	9	20	15	13,000	70	81		
			18				35 1/2							26					21	
	24	41 1/2	32				27							1 1/4-7NC					33	90
	30	47 1/2	38				33							98						
	36	53 1/2	44	39	108															
	55 MM	ZHT75055MM	304.80	112.71	698.50	-	749.30	104.77	101.60	15.88	30.16	173.04	228.60	508.00	1 1/4-7NC	381.00	57824.00	317.45		
457.20			850.90				660.40							533.40					367.34	
609.60	1003.30	812.80	685.80				408.15													
762.00	1155.70	965.20	838.20				444.43													
	914.40	1308.10	1117.60	990.60	489.78															
8	2 7/16	ZHT85207	12	4 3/8	28 1/2	-	30 1/2	4 3/8	4	3/4	3/4	7 1/2	9 3/16	20	15	16,300	77	86		
			18				36 1/2							26					21	
	24	42 1/2	32				27							1 1/4-7NC					33	96
	30	48 1/2	38				33							107						
	36	54 1/2	44	39	119															
	60 MM	ZHT85060MM	304.80	111.13	723.90	-	774.70	111.13	101.60	19.05	19.05	190.50	233.36	508.00	1 1/4-7NC	381.00	72502.40	349.20		
457.20			876.30				660.40							533.40					390.01	
609.60	1028.70	812.80	685.80				435.36													
762.00	1181.10	965.20	838.20				485.25													
	914.40	1333.50	1117.60	990.60	539.67															

Continued...

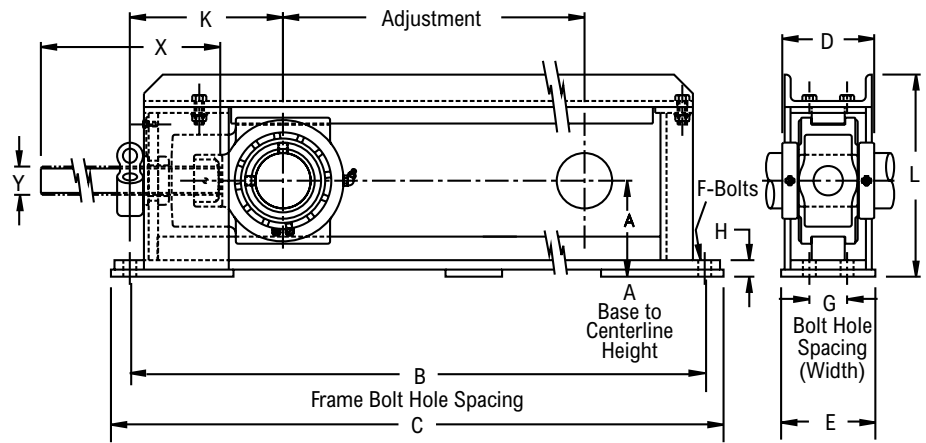


Continued...

Bearing Dimensions

Size Code	Shaft Diameter	Complete Take-up Assembly	Travel Length	A Base to Centerline Height	B Frame Bolt Hole Spacing	G Bolt Hole Spacing (Width)	C	D	E	F	H	K	L	X	Y	Adjust.	Allowable Working Load	Approx. Weight	
4-Bolt																			
9	2 1/2	ZHT95208	12	5 1/8	30 1/2	2	32 1/2	4 7/8	5	5/8	7/8	8 1/8	10 3/4	21 3/4	1 1/2-6NC	16	26,800	128	
			18		36 1/2		38 1/2							44 1/2		27 3/4		22	142
			24		42 1/2		44 1/2							33 3/4		28		159	
			30	48 1/2	50 1/2	39 3/4	34	174											
			36	54 1/2	56 1/2	45 3/4	40	191											
		70 MM	ZHT95070MM	304.80 457.20 609.60 762.00 914.40	130.18	774.70 927.10 1079.50 1231.90 1384.30	50.80	825.50 977.90 1130.30 1282.70 1435.10	123.83	127.00	15.88	22.22	166.70	206.38	552.45 704.85 857.25 1009.65 1162.05	1 1/2-6NC	406.40 558.80 711.20 863.60 1016.00	119,206.40	580.48 643.97 721.07 789.09 866.19
10	3 3/16	ZHT105303	12	5 5/8	32	2	34 1/4	5 5/16	5	3/4	7/8	8 3/4	11 13/16	22	1 3/4-5NC	16 1/4	27,300	152	
			18		38		40 1/4							28		177			
			24		44		46 1/4							34		186			
			30	50	52 1/4	40	205												
			36	56	58 1/4	46	224												
		80 MM	ZHT105080MM	304.80 457.20 609.60 762.00 914.40	142.88	812.80 965.20 1117.60 1270.00 1422.40	50.80	869.95 1022.35 1174.75 1327.15 1479.55	134.94	127.00	19.05	22.22	222.25	300.04	558.80 711.20 863.60 1016.00 1168.40	1 3/4-5NC	444.50 596.90 749.30 901.70 1054.10	121,430.40	689.32 802.70 843.51 929.68 1015.84
11	3 11/16	ZHT115311	12	7	36	2 1/2	38 1/2	6 1/4	6	3/4	7/8	10 5/8	14 3/16	26	2-4 1/2NC	17 1/2	38,400	241	
			18		42		44 1/2							32		270			
			24		48		50 1/2							38		290			
			30	54	56 1/2	44	311												
			36	60	62 1/2	50	337												
		100 MM	ZHT115100MM	304.80 457.20 609.60 762.00 914.40	177.80	914.40 1066.80 1219.20 1371.60 1524.00	63.50	977.90 1130.30 1282.70 1435.10 1587.50	158.75	152.40	19.05	22.22	269.88	360.36	660.40 812.80 965.20 1117.60 1270.00	2-4 1/2NC	444.50 596.90 749.30 901.70 1054.10	170,803.20	1092.94 1224.45 1315.15 1410.39 1528.30
12	4 3/16	ZHT125403Y	12	7 1/2	40 3/4	5	45 3/4	6 1/4	8 7/8	1 1/8	1	12 1/4	15 1/2	26	2-4 1/2 NC	19	53,300	331	
			18		46 3/4		51 3/4							32		362			
			24		52 3/4		57 3/4							38		391			
			30	58 3/4	63 3/4	44	410												
			36	64 3/4	69 3/4	50	433												
			42	70 3/4	75 3/4	56	461												

Continued...



Continued...

Bearing Dimensions

Size Code	Shaft Diameter	Complete Take-up Assembly	Travel Length	A Base to Centerline Height	B Frame Bolt Hole Spacing	G Bolt Hole Spacing (Width)	C	D	E	F	H	K	L	X	Y	Adjust.	Allowable Working Load	Approx. Weight
4-Bolt (continued)																		
12	110 MM	ZHT125110MM	304.80 457.20 609.60 762.00 914.40 1066.80	190.50	1035.05 1187.45 1339.85 1466.85 1644.65 1797.05	127.00	1111.25 1314.45 1466.85 1619.25 1009.65 1924.05	158.75	225.43	28.58	25.40	309.88	393.70	660.40 812.80 965.20 1117.60 1270.00 1422.40	2-4 1/2NC	482.60 635.00 787.40 939.80 1092.20 1244.60	237,078.40	1501.09 1641.67 1773.19 1859.35 1963.66 2090.64
	115 MM	ZHT125115MM																
13	4 15/16	ZHT135415	12 18 24 30	8 1/8	44 1/2 50 1/2 56 1/2 62 1/2	5 1/2	49 1/2 55 1/2 61 1/2 67 1/2	7 7/8	9 7/8	1 1/8	1	13 1/2	16 3/4	29 35 41 47	2 1/4- 4 1/2 NC	20 1/4 26 1/4 32 1/4 38 1/4	68,000	440 460 496 527
		5	ZHT135500		36 42		68 1/2 74 1/2							73 1/2 79 1/2		53 59		44 1/4 50 1/4
	125 MM	ZHT135125MM	304.80 457.20 609.60 762.00 914.40 1066.80	206.37	1130.30 1282.70 1435.10 1587.50 1739.90 1892.30	139.70	1257.30 1409.70 1562.10 1714.50 1866.90 2019.30	200.00	250.83	28.50	25.40	342.90	171.45	745.49 1041.40 1193.80 1361.19 1866.90 2019.30	2-4 1/2NC	514.35 666.75 819.15 971.55 1123.95 1276.35	302,464.00	1995.40 2086.10 2249.36 2389.95 2516.93 2662.05
		130 MM	ZHT135135MM															
14	5 7/16	ZHT145507	18 30 42	10 9/16	55 67 79	7	61 73 85	8	12	1 3/4	1 1/2	23 1/2	22 1/2	36 48 60	3- 4 NC	18 30 42	136,700	1293 1420 1547
	140 MM	ZHT145140MM	457.20 762.00 1066.80	298.29	1397.00 1701.80 2006.60	177.80	1549.40 1854.20 2159.00	203.20	304.80	44.45	12.70	596.90	571.50	914.40 1219.20 1524.00	3-4NC	457.20 762.00 1066.80	608,041.60	5863.76 6439.70 7015.65
15	5 15/16	ZHT155515	18 30 42	10 9/16	55 67 79	7	61 73 85	8 1/8	12	1 3/4	1 1/2	23 1/2	22 1/2	36 48 60	3- 4 NC	18 30 42	136,700	1300 1427 1554
	150 MM	ZHT155150MM	457.20 762.00 1066.80	298.29	1397.00 1701.80 2006.60	177.80	1549.40 1854.20 2159.00	206.38	304.80	44.45	12.70	596.90	571.50	914.40 1219.20 1524.00	3-4NC	457.20 762.00 1066.80	608,041.60	5895.50 6471.45 7047.39
	160 MM	ZHT155160MM																
16	6 7/16	ZHT165607	18 30 42	10 9/16	55 67 79	7	61 73 85	8 3/4	12	1 3/4	1 1/2	23 1/2	22 1/2	36 48 60	3-4 NC	18 30 42	136,700	1304 1431 1558
	6 15/16	ZHT165615																
	7	ZHT165700																
180 MM	ZHT165180MM	457.20 762.00 1066.80	298.29	1397.00 1701.80 2006.60	177.80	1549.40 1854.20 2159.00	222.25	304.80	44.45	12.70	596.90	571.50	914.40 1219.20 1524.00	3-4NC	457.20 762.00 1066.80	608,041.60	5913.64 6489.59 7065.53	

Additional Notes

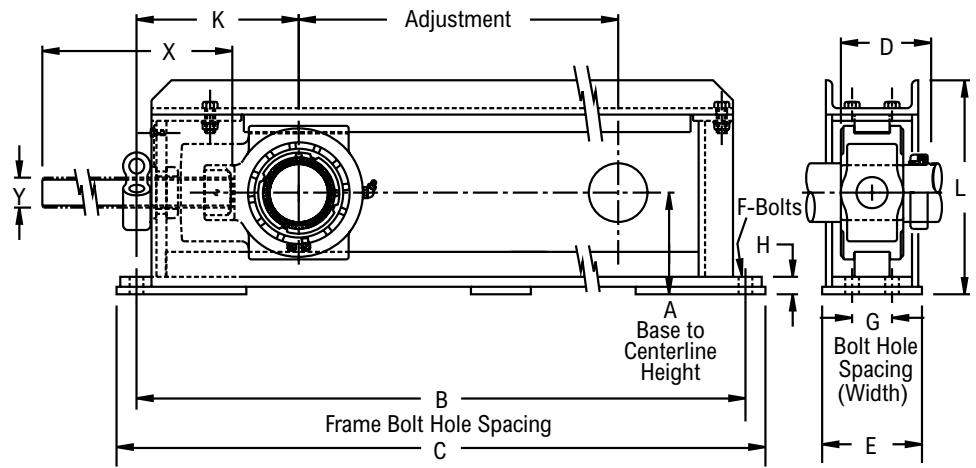
Please call 1-866-REXNORD for availability
 Metric bore sizes available, see Rex Interchangeability guide
 Lubrication fitting tap size: for size code 5 thru 11, 1/8" PT; for all other size codes, 1/4" PT
 Bore size = nominal shaft size +.001 in/-.000 in (+0.03 mm/-0.00 mm)
 Seals - To specify G, K or M seal, replace "Z" in part number with "G", "K" or "M"
 "G" seals only available in size codes 5 thru 13

"K" seals only available in size codes 5 thru 11
 Auxiliary end caps - available in all size codes
 Allowable working load is 2/3 yield strength
 For the Selection Guide, Load Ratings and Speed Limits, see the Spherical Roller Bearings Engineering section on pages 15 - 27.
 Note: Dimensions subject to change. Certified dimensions of ordered material furnished on request.

ZHT6000



Photo Shows a Center Pull Take-up Frame with Spherical Roller Bearing Take-up Unit



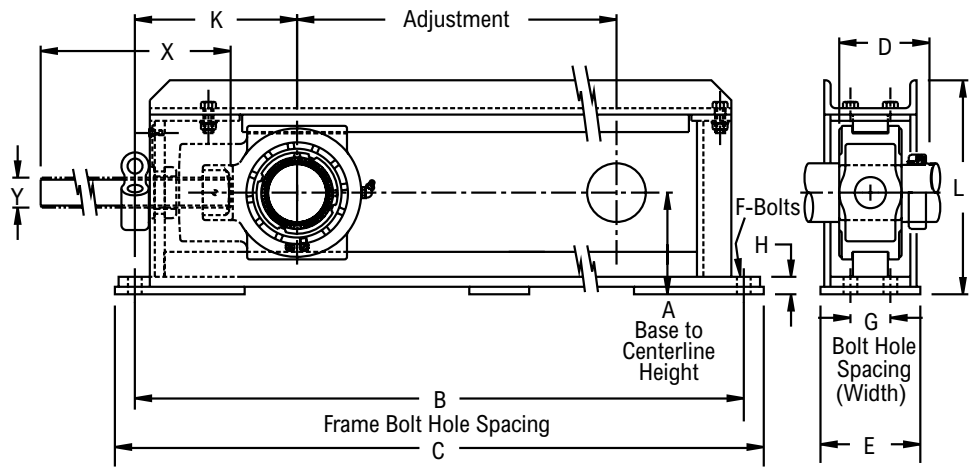
Product Features

- Spyglass Optical Strain Sensor (OSS) Technology
- Positive locking system
- Tapered adapter sleeve
- Center pull type frame
- Corrosion-resistant powder coating
- Cast iron housing
- Misalignment capabilities - total of 3°
- Broad range of sealing options
- Factory set clearance & lubrication
- See Features and Benefits for additional info on pages 10 - 13.

Bearing Dimensions

Size Code	Shaft Diameter	Complete Take-up Assembly	Travel Length	A Base to Centerline Height	B Frame Bolt Hole Spacing	G Bolt Hole Spacing (Width)	C	D	E	F	H	K	L	X	Y	Adjust.	Allowable Working Load	Approx. Weight
2-Bolt																		
5	1 15/16	ZHT56111	12.000	3 15/16	27 1/2	-	29 1/2	3 41/64	4	5/8	7/8	6 9/16	8 7/16	19 1/2	1-8 NC	15	12,300	59.00 lb
			18.000		33 1/2		35 1/2							25 1/2		21		69.00 lb
			24.000		39 1/2		41 1/2							31 1/2		27		77.00 lb
			30.000		45 1/2		47 1/2							37 1/2		33		86.00 lb
			36.000		51 1/2		53 1/2							43 1/2		39		95.00 lb
6	1 15/16	ZHT66115	12	3 15/16	27 1/2	-	29 1/2	3 41/64	4	5/8	7/8	6 9/16	8 7/16	19 1/2	1-8 NC	15	12,300	59
			18		33 1/2		35 1/2							25 1/2		21		69
			24		39 1/2		41 1/2							31 1/2		27		77
			30		45 1/2		47 1/2							37 1/2		33		86
			36		51 1/2		53 1/2							43 1/2		39		95
	45 MM	ZHT66045MM	304.80	100.01	698.50	-	749.30	92.47	101.60	15.88	22.22	166.70	214.31	495.30	1-8NC	381.00	54,710.40	267.57
			457.20		850.90		901.70							647.70		533.40		312.92
			609.60		1003.30		1054.10							800.10		685.80		349.20
			762.00		1155.70		1206.50							952.50		838.20		390.01
			914.40		1308.10		1358.90							1104.90		990.60		430.83
7	2 3/16	ZHT76203	12	4 7/16	27 1/2	-	29 1/2	3 49/64	4	5/8	1 3/16	6 13/16	9	20	1 1/4-7 NC	15	13,000	70
			18		33 1/2		35 1/2							26		21		81
			24		39 1/2		41 1/2							32		27		90
			30		45 1/2		47 1/2							38		33		98
			36		51 1/2		53 1/2							44		39		108
	55 MM	ZHT76055MM	304.80	112.71	698.50	-	749.30	95.65	101.60	15.88	30.16	173.04	228.60	508.00	1 1/4-7NC	381.00	57,824.00	317.45
			457.20		850.90		901.70							660.40		533.40		367.34
			609.60		1003.30		1054.10							812.80		685.80		408.15
			762.00		1155.70		1206.50							965.20		838.20		444.43
			914.40		1308.10		1358.90							1117.60		990.60		489.78
8	2 3/8	ZHT86206	12	4 3/8	28 1/2	-	30 1/2	4 5/32	4	3/4	3/4	7 1/2	9 3/16	20	1 1/4-7 NC	15	16,300	77
			18		34 1/2		36 1/2							26		21		86
			24		40 1/2		42 1/2							32		27		96
			30		46 1/2		48 1/2							38		33		107
			36		52 1/2		54 1/2							44		39		119
	60 MM	ZHT86060MM	304.80	111.13	723.90	-	774.70	105.57	101.60	19.05	19.05	190.50	233.36	508.00	1 1/4-7NC	381.00	72502.40	349.20
			457.20		876.30		927.10							660.40		533.40		390.01
			609.60		1028.70		1079.50							812.80		685.80		435.36
			762.00		1181.10		1231.90							965.20		838.20		485.25
			914.40		1333.50		1384.30							1117.60		990.60		539.67

Continued...

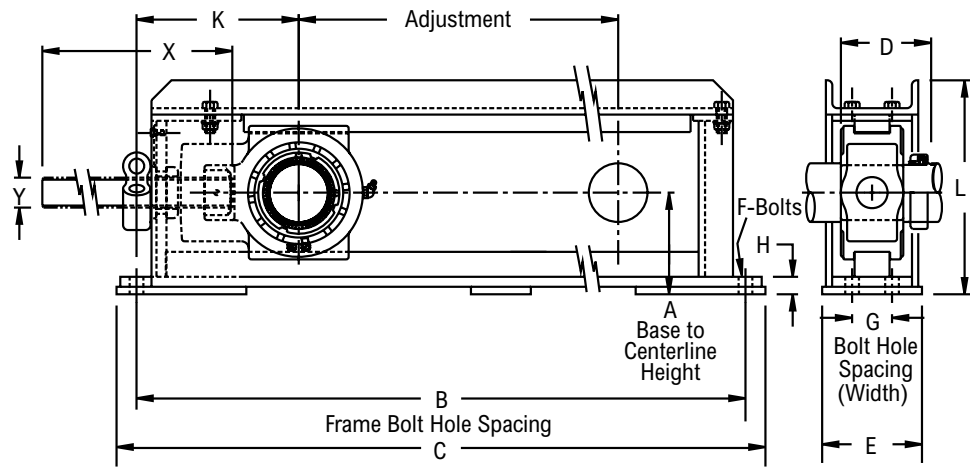


Continued...

Bearing Dimensions

Size Code	Shaft Diameter	Complete Take-up Assembly	Travel Length	A Base to Centerline Height	B Frame Bolt Hole Spacing	G Bolt Hole Spacing (Width)	C	D	E	F	H	K	L	X	Y	Adjust.	Allowable Working Load	Approx. Weight	
4-Bolt																			
9	2 11/16	ZHT96211	12	5 1/8	30 1/2	2	32 1/2	4 17/32	5	5/8	7/8	8 1/8	10 3/4	21 3/4	1 1/2-6 NC	16	26,800	128	
			18		36 1/2		38 1/2							27 3/4				22	142
	2 3/4	ZHT96212	24		42 1/2		44 1/2							33 3/4				28	159
			30	48 1/2	50 1/2	39 3/4	34	174											
		2 15/16	ZHT96215	36	54 1/2	56 1/2	45 3/4	40	191										
	70 MM	ZHT96070MM	304.80 457.20 609.60 762.00 914.40	130.18	774.70 927.10 1079.50 1231.90 1384.30	50.80	825.50 977.90 1130.30 1282.70 1435.10	115.09	127.00	15.88	22.22	166.70	206.38	552.45 704.85 857.25 1009.65 1162.05	1 1/2-6NC	406.40 558.80 711.20 863.60 1016.00	119206.40	580.48 643.97 721.07 789.09 866.19	
	75 MM	ZHT96075MM																	
10	3 3/16	ZHT106303	12	5 5/8	32	2	34 1/4	5 9/64	5	3/4	7/8	8 3/4	11 13/16	22	1 3/4-5 NC	16 1/4	27,300	152	
			18		38		40 1/4							28				177	
			24		44		46 1/4							34				186	
		3 7/16	ZHT106307	30	50	52 1/4	40	34 1/4	205										
			36	56	58 1/4	46	40 1/4	224											
	80 MM	ZHT106080MM	304.80 457.20 609.60 762.00 914.40	142.88	812.80 965.20 1117.60 1270.00 1422.40	50.80	869.95 1022.35 1174.75 1327.15 1479.55	130.57	127.00	19.05	22.22	222.25	300.04	558.80 711.20 863.60 1016.00 1168.40	1 3/4-5NC	444.50 596.90 749.30 901.70 1054.10	121,430.40	689.32 802.70 843.51 929.68 1015.84	
	85 MM	ZHT106085MM																	
11	3 11/16	ZHT116311	12	7	36	2 1/2	38 1/2	5 31/32	6	3/4	7/8	10 5/8	14 3/16	26	2-4 1/2 NC	17 1/2	38,400	241	
			18		42		44 1/2							32				270	
			24		48		50 1/2							38				290	
		3 15/16	ZHT116315	30	54	56 1/2	44	35 1/2	311										
			36	60	62 1/2	50	41 1/2	337											
	90 MM	ZHT116090MM	304.80 457.20 609.60 762.00 914.40	177.80	914.40 1066.80 1219.20 1371.60 1524.00	63.50	977.90 1130.30 1282.70 1435.10 1587.50	151.61	152.40	19.05	22.22	269.88	360.36	660.40 812.80 965.20 1117.60 1270.00	2-4 1/2NC	444.50 596.90 749.30 901.70 1054.10	170803.20	1092.94 1224.45 1315.15 1410.39 1528.30	
	100 MM	ZHT116100MM																	
12	4 3/16	ZHT126403Y	12	7 1/2	40 3/4	5	45 3/4	6 1/4	8 7/8	1 1/8	1	12 1/4	15 1/2	26	2-4 1/2 NC	19	53,300	331	
			18		46 3/4		51 3/4							32				362	
			24		52 3/4		57 3/4							38				391	
		4 7/16	ZHT126407Y	30	58 3/4	63 3/4	44	37	410										
			36	64 3/4	69 3/4	50	43	433											
			42	70 3/4	75 3/4	56	49	461											
	110 MM	ZHT126110MM	304.80 457.20 609.60 762.00 914.40 1066.80	190.50	1035.05 1187.45 1339.85 1492.25 1644.65 1797.05	127.00	1111.25 1314.45 1466.85 1619.25 1009.65 1924.05	158.75	225.43	28.58	25.40	309.88	393.70	660.40 812.80 965.20 1117.60 1270.00 1422.40	2-4 1/2NC	482.60 635.00 787.40 939.80 1092.20 1244.60	237,078.40	1501.09 1641.67 1773.19 1859.35 1963.66 2090.64	

Continued...



Continued...

Bearing Dimensions

Size Code	Shaft Diameter	Complete Take-up Assembly	Travel Length	A Base to Centerline Height	B Frame Bolt Hole Spacing	G Bolt Hole Spacing (Width)	C	D	E	F	H	K	L	X	Y	Adjust.	Allowable Working Load	Approx. Weight
4-Bolt (continued)																		
13	4 ^{15/16}	ZHT136415	12	8 1/8	44 1/2	5 1/2	49 1/2	7 15/16	9 7/8	1 1/8	1	13 1/2	16 3/4	29	2 1/4-4 1/2 NC	20 1/4	68,000	440
			18		50 1/2		55 1/2							61 1/2				67 1/2
			24		56 1/2		61 1/2							41		32 1/4		527
			30		62 1/2		67 1/2							47		38 1/4		555
			36		68 1/2		73 1/2							53		44 1/4		587
			42		74 1/2		79 1/2							59		50 1/4		
	125 MM	ZHT136125MM	304.80	206.37	1130.30	139.70	1257.30	198.44	250.83	28.50	25.40	342.90	171.45	745.49	2-4 1/2 NC	514.35	302,464.00	1995.40
			457.20		1282.70		1409.70							1041.40		666.75		2086.10
			609.60		1435.10		1562.10							1193.80		819.15		2249.36
			762.00		1587.50		1714.50							1361.19		971.55		2389.95
			914.40		1739.90		1866.90							1866.90		1123.95		2516.93
			1066.80		1892.30		2019.30							2019.30		1276.35		2662.05

Additional Notes

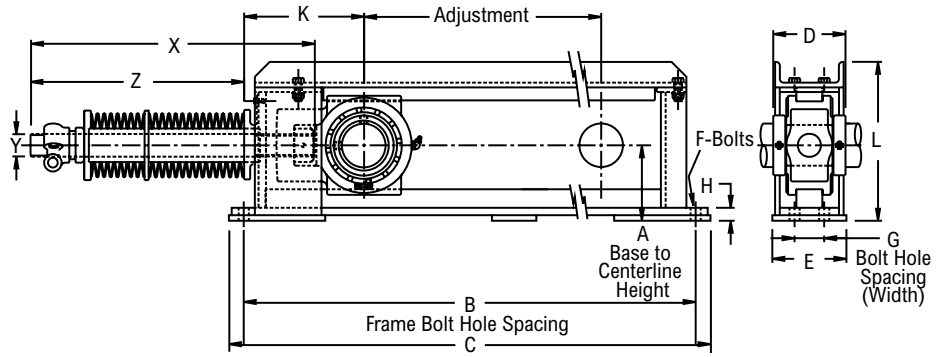
- Please call 1-866-REXNORD for availability
- Lubrication fitting tap size: for size code 6 thru 11, 1/8" PT; for all other size codes, 1/4" PT
- Seals - To specify G, K or M seal, replace "Z" in part number with "G", "K" or "M"
- "K" seals only available in size codes 5 thru 11
- Auxiliary end caps - available in all size codes
- Allowable working load is 2/3 yield strength

For the Selection Guide, Load Ratings and Speed Limits, see the Spherical Roller Bearings Engineering section on pages 15 - 27.

Note: Dimensions subject to change. Certified dimensions of ordered material furnished on request.



Photo Shows a Center Pull Spring Loaded Take-up Frame with Spherical Roller Bearing Take-up Unit



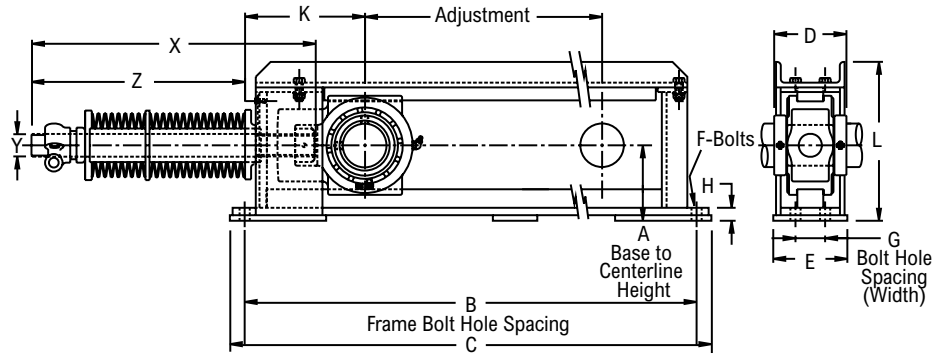
Product Features

- Center pull type spring loaded frame
- Corrosion-resistant powder coating
- Cast iron housing
- Misalignment capabilities - total of 3°
- Broad range of sealing options
- Factory set clearance & lubrication
- Precision ground & superfinished raceways
- Field interchangeable seals
- See Features and Benefits for additional info on pages 10 - 13.

Bearing Dimensions

Size Code	Shaft Diameter	Part Number	A	B	C	D	E	F	G	H	K	L	X	Y	Z	Working Load Inches of Spring Deflection			Allowable Working Load	Approx. Weight
																1	3	5		
2-Bolt																				
5	1 1/2	ZST5510818	3 15/16	33 1/2	35 1/2	3 13/16	4	5/8	-	7/8	6 9/16	8 7/16	43	1-8 NC	39	870	1,800	3,400	12,300	69.00
	1 1/16	ZST5511118																		
	40.00	ZST55040MM18	100.01	851.00	902.00	96.84	101.60	16.00	-	22.23	166.69	214.31	648.00	1-8 NC	990.60	395	816	1,540	5,580	31.00
	45.00	ZST55045MM18																		
6	1 15/16	ZST6511518	3 15/16	33 1/2	35 1/2	3 13/16	4	5/8	-	7/8	6 9/16	8 7/16	43	1-8 NC	39	870	1,800	3,400	12,300	69.00
	50.00	ZST65050MM18	100.01	851.00	902.00	96.84	101.60	16.00	-	22.23	166.69	214.31	648.00	1-8 NC	990.60	395	816	1,540	5,580	31.00
7	2	ZST7520018	4 7/16	33 1/2	35 1/2	4 1/8	4	5/8	-	1 3/16	6 13/16	9	43	1 1/4 -7 NC	39	870	1,800	3,400	13,000	81.00
	2 3/16	ZST7520318																		
	55.00	ZST75055MM18	112.71	851.00	902.00	104.78	101.60	16.00	-	30.16	173.04	228.60	660.00	1 1/4 -7 NC	990.60	395	816	1,540	5,890	37.00
8	2 7/16	ZST8520718	4 3/8	34 1/2	36 1/2	4 3/8	4	3/4	-	3/4	7 1/2	9 3/16	43	1 1/4 -7 NC	39	870	1,800	3,400	16,300	86.00
	60.00	ZST85060MM18																		
	65.00	ZST85065MM18	111.13	876.00	927.00	111.13	101.60	19.00	-	19.05	190.50	233.36	660.00	1 1/4 -7 NC	990.60	395	816	1,540	7,390	39.00
4-Bolt																				
9	2 1/2	ZST9520818	5 1/8	36 1/2	38 1/2	4 7/8	5	5/8	2	7/8	8 1/8	10 3/4	45	1 1/2-6 NC	40 1/4	1,300	3,400	5,250	26,800	142.00
	2 11/16	ZST9521118																		
	2 15/16	ZST9521518	130.18	927.00	978.00	123.83	127.00	16.00	50.80	22.23	206.38	273.05	705.00	1 1/2-6 NC	1,022.35	590	1,540	2,380	12,150	65.00
	70.00	ZST95070MM18																		
75.00	ZST95075MM18																			
10	3 3/16	ZST10530318	5 5/8	38	40 1/4	5 5/16	5	3/4	2	7/8	8 3/4	11 13/16	45	1 3/4-5 NC	40 1/4	1,800	3,700	6,800	27,300	177.00
	3 7/16	ZST10530718																		
	80.00	ZST105080MM18	142.88	965.00	1,022.00	134.94	127.00	19.00	50.80	22.23	222.25	300.04	711.00	1 3/4-5 NC	1,022.35	816	1,680	3,080	12,380	80.00
	85.00	ZST105085MM18																		
90.00	ZST105090MM18																			
11	3 11/16	ZST11531118	7	42	44 1/2	6 1/8	6	3/4	2 1/2	7/8	10 5/8	14 3/16	48 1/2	2-4 1/2 NC	41	2,600	5,200	9,400	38,400	270.00
	3 15/16	ZST11531518																		
	4	ZST11540018	177.80	1,067.00	1,130.00	155.58	152.40	19.00	63.50	22.23	269.88	360.36	812.00	2-4 1/2 NC	1,041.40	1,180	2,350	4,260	17,410	123.00

Continued...



Continued...

Bearing Dimensions

Size Code	Shaft Diameter	Part Number	A	B	C	D	E	F	G	H	K	L	X	Y	Z	Working Load Inches of Spring Deflection			Allowable Working Load	Approx. Weight
																1	3	5		
4-Bolt (continued)																				
12	4 ³ / ₁₆	ZST125403Y18	7 1/2	46 3/4	51 3/4	6 1/4	8 7/8	1 1/8	5	1	12 1/4	15 1/2	48 1/2	2-4 1/2 NC	41	2,600	5,200	9,400	53,300	362.00
	4 ⁷ / ₁₆	ZST125407Y18																		
	110.00	ZST125110MM18	190.50	1,187.00	1,314.00	158.75	225.43	28.00	127.00	25.40	311.15	393.70	813.00	2-4 1/2 NC	1,041.40	1,180	2,350	4,260	24,170	164.00
	115.00	ZST125115MM18																		
13	4 ¹⁵ / ₁₆	ZST13541518	8 1/8	50 1/2	55 1/2	7 7/8	9 7/8	1 1/8	5 1/2	1	13 1/2	16 3/4	52	2 1/4-4 1/2 NC	45 1/2	1,180	2,350	4,260	68,000	460.00
	5	ZST13550018																		
	125.00	ZST135125MM18	206.38	1,283.00	1,410.00	200.03	250.83	28.00	139.70	25.40	342.90	425.45	889.00	2 1/4-4 1/2 NC	1,155.70	2,030	5,080	8,160	30,800	209.00
	130.00	ZST135130MM18																		

Additional Notes

- Please call 1-866-REXNORD for availability
- Metric bore sizes available, see Rex Interchangeability guide
- Lubrication fitting tap size: for size code 5 thru 11, 1/8" PT; for all other size codes, 1/4" PT
- Bore size = nominal shaft size +.001 in/-.000 in (**+0.03 mm/-0.00 mm**)
- Seals - To specify "G", K or M seal, replace "Z" in part number with "G", "K" or "M"
- "K" seals only available in size codes 5 thru 11
- Auxiliary end caps - available in all size codes

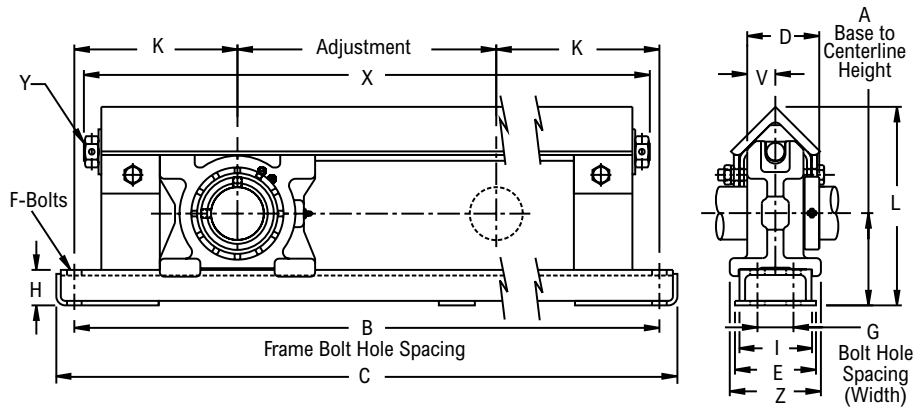
- Allowable frame load is 2/3 yield strength
- For the Selection Guide, Load Ratings and Speed Limits, see the Spherical Roller Bearings Engineering section on pages 15 - 27.
- Note: Dimensions subject to change. Certified dimensions of ordered material furnished on request.



Photo Shows a Protected Screw Type Take-up Frame with Spherical Roller Bearing Take-up Unit

Product Features

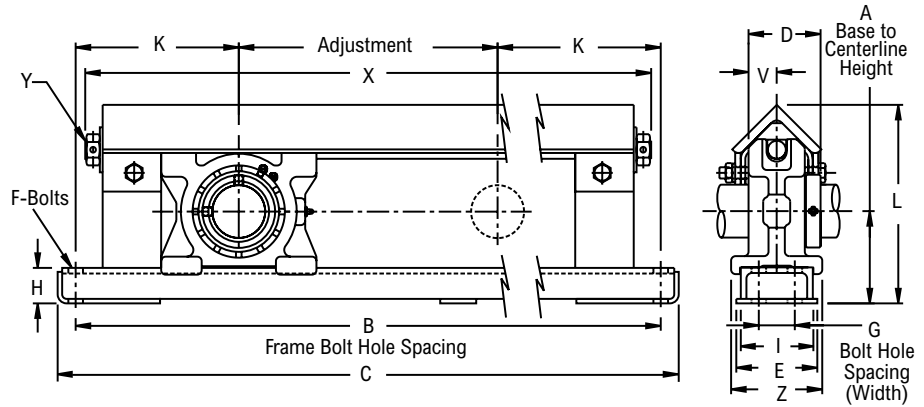
- Protected screw type frame
- Corrosion-resistant powder coating
- Cast iron housing
- Misalignment capabilities - total of 3°
- Broad range of sealing options
- Factory set clearance & lubrication
- Precision ground & superfinished raceways
- Field interchangeable seals
- See Features and Benefits for additional info on pages 10 - 13.



Bearing Dimensions

Size Code	Shaft Diameter	Complete Take-up Assembly	Travel Length	A Base to Centerline Height	B Frame Bolt Hole Spacing	G Bolt Hole Spacing (Width)	C	D	E	F	H	I	K	L	V	X	Y	Z	Adjust.	Allowable Working Load	Approx. Weight										
2-Bolt																															
6	1 15/16	ZNT62115	12 18 24 30 36	3 15/16	26 1/2 32 1/2 38 1/2 44 1/2 50 1/2	-	28 1/2 34 1/2 40 1/2 46 1/2 52 1/2	3 1/8	3 1/2	5/8	1 3/4	3	7 1/4	8 1/4	1 7/32	25 3/8 31 3/8 37 3/8 43 3/8 49 3/8	3/4 - 10NC	3 13/16	12 18 24 30 36	3,000	45 50 56 63 70										
	2	ZNT62200	304.80 457.20 609.60 762.00 914.40		673.10 825.50 977.90 1130.30 1282.70	-	723.90 876.30 1028.70 1181.10 1333.50									79.38			88.90		15.88	44.45	76.20	184.15	209.55	30.96	644.53 796.93 949.33 1101.73 1254.13	3/4 - 10NC	304.80 457.20 609.60 762.00 914.40	13344.00	235.82 263.03 294.78 326.52
	50 MM	ZNT62050MM	304.80 457.20 609.60 762.00 914.40		673.10 825.50 977.90 1130.30 1282.70	-	723.90 876.30 1028.70 1181.10 1333.50									79.38			88.90		15.88	44.45	76.20	184.15	209.55	30.96	644.53 796.93 949.33 1101.73 1254.13	3/4 - 10NC	304.80 457.20 609.60 762.00 914.40	13344.00	235.82 263.03 294.78 326.52
	55 MM	ZNT72055MM	304.80 457.20 609.60 762.00 914.40		698.50 850.90 1003.30 1155.70 1308.10	-	749.30 901.70 1054.10 1206.50 1358.90									84.14			88.90		15.88	44.45	76.20	196.85	220.66	32.54	669.93 822.33 974.73 1127.13 1279.53	3/4 - 10NC	304.80 457.20 609.60 762.00 914.40	16012.80	222.22 244.89 299.31 331.06 353.73
7	2 3/16	ZNT72203	12 18 24 30 36	4 3/16	27 1/2 33 1/2 39 1/2 45 1/2 51 1/2	-	29 1/2 35 1/2 41 1/2 47 1/2 53 1/2	3 5/16	3 1/2	5/8	1 3/4	3	7 3/4	8 11/16	1 9/32	26 3/8 32 3/8 38 3/8 44 3/8 50 3/8	3/4 - 10NC	3 13/16	12 18 24 30 36	3,600	49 54 66 73 78										
	2 1/4	ZNT72204	304.80 457.20 609.60 762.00 914.40		698.50 850.90 1003.30 1155.70 1308.10	-	749.30 901.70 1054.10 1206.50 1358.90									84.14			88.90		15.88	44.45	76.20	196.85	220.66	32.54	669.93 822.33 974.73 1127.13 1279.53	3/4 - 10NC	304.80 457.20 609.60 762.00 914.40	16012.80	222.22 244.89 299.31 331.06 353.73
	55 MM	ZNT72055MM	304.80 457.20 609.60 762.00 914.40		698.50 850.90 1003.30 1155.70 1308.10	-	749.30 901.70 1054.10 1206.50 1358.90									84.14			88.90		15.88	44.45	76.20	196.85	220.66	32.54	669.93 822.33 974.73 1127.13 1279.53	3/4 - 10NC	304.80 457.20 609.60 762.00 914.40	16012.80	222.22 244.89 299.31 331.06 353.73
	60 MM	ZNT82060MM	304.80 457.20 609.60 762.00 914.40		723.90 876.30 1028.70 1181.10 1333.50	-	774.70 927.10 1079.50 1231.90 1384.30									88.90			88.90		19.05	44.45	76.20	209.55	231.78	33.34	704.85 857.25 1009.65 1162.05 1314.45	7/8 - 9NC	304.80 457.20 609.60 762.00 914.40	19751.20	267.57 285.71 335.59 358.27 385.48
8	2 3/8	ZNT82206	12 18 24 30 36	4 3/8	28 1/2 34 1/2 40 1/2 46 1/2 52 1/2	-	30 1/2 36 1/2 42 1/2 48 1/2 54 1/2	3 1/2	3 1/2	3/4	1 3/4	3	8 1/4	9 1/8	1 5/16	27 3/4 33 3/4 39 3/4 45 3/4 51 3/4	7/8 - 9NC	3 15/16	12 18 24 30 36	4,400	59 63 74 79 85										
	2 7/16	ZNT82207	304.80 457.20 609.60 762.00 914.40		723.90 876.30 1028.70 1181.10 1333.50	-	774.70 927.10 1079.50 1231.90 1384.30									88.90			88.90		19.05	44.45	76.20	209.55	231.78	33.34	704.85 857.25 1009.65 1162.05 1314.45	7/8 - 9NC	304.80 457.20 609.60 762.00 914.40	19751.20	267.57 285.71 335.59 358.27 385.48
	2 1/2	ZNT82208	304.80 457.20 609.60 762.00 914.40		723.90 876.30 1028.70 1181.10 1333.50	-	774.70 927.10 1079.50 1231.90 1384.30									88.90			88.90		19.05	44.45	76.20	209.55	231.78	33.34	704.85 857.25 1009.65 1162.05 1314.45	7/8 - 9NC	304.80 457.20 609.60 762.00 914.40	19751.20	267.57 285.71 335.59 358.27 385.48
	60 MM	ZNT82060MM	304.80 457.20 609.60 762.00 914.40		723.90 876.30 1028.70 1181.10 1333.50	-	774.70 927.10 1079.50 1231.90 1384.30									88.90			88.90		19.05	44.45	76.20	209.55	231.78	33.34	704.85 857.25 1009.65 1162.05 1314.45	7/8 - 9NC	304.80 457.20 609.60 762.00 914.40	19751.20	267.57 285.71 335.59 358.27 385.48
9	331.06	ZNT92211	12 18 24 30 36	5 1/8	30 1/2 36 1/2 42 1/2 48 1/2 54 1/2	2	32 1/2 38 1/2 44 1/2 50 1/2 56 1/2	4	4 1/2	3/4	2	4	9 1/4	10 5/8	1 9/16	30 36 42 48 54	1 - 8NC	5 1/16	12 18 24 30 36	6,800	85 93 113 120 128										
	353.73	ZNT92215	304.80 457.20 609.60 762.00 914.40		723.90 876.30 1028.70 1181.10 1333.50	2	774.70 927.10 1079.50 1231.90 1384.30									88.90			88.90		19.05	44.45	76.20	209.55	231.78	33.34	704.85 857.25 1009.65 1162.05 1314.45	7/8 - 9NC	304.80 457.20 609.60 762.00 914.40	19751.20	267.57 285.71 335.59 358.27 385.48
	3	ZNT92300	304.80 457.20 609.60 762.00 914.40		723.90 876.30 1028.70 1181.10 1333.50	2	774.70 927.10 1079.50 1231.90 1384.30									88.90			88.90		19.05	44.45	76.20	209.55	231.78	33.34	704.85 857.25 1009.65 1162.05 1314.45	7/8 - 9NC	304.80 457.20 609.60 762.00 914.40	19751.20	267.57 285.71 335.59 358.27 385.48

Continued...



Continued...

Bearing Dimensions

Size Code	Shaft Diameter	Complete Take-up Assembly	Travel Length	A Base to Centerline Height	B Frame Bolt Hole Spacing	G Bolt Hole Spacing (Width)	C	D	E	F	H	I	K	L	V	X	Y	Z	Adjust.	Allowable Working Load	Approx. Weight	
4-Bolt (continued)																						
9	70 MM	ZNT92070MM	304.80 457.20 609.60	130.18	774.70 927.10	50.80	825.50 977.90	101.60	114.30	19.05	50.80	101.60	234.95	269.88	39.69	762.00 914.40	1-8NC		304.80 457.20	30246.40	385.48 421.76	
			762.00 914.40		1079.50 1231.90 1384.30		1130.30 1282.70 1435.10									1066.80 1219.20 1371.60			609.60 762.00 914.40		512.46 544.20 580.48	
	75 MM	ZNT92075MM																				
10	3 3/16	ZNT102303	12 18 24 30	5 5/8	32 38 44	2	34 1/4 40 1/4 46 1/4	4 3/8	4 1/2	3/4	2	4	10	11 3/4	1 23/32	32 38 44	1 1/8-7NC	5 3/16	12 18 24 30 36	8,400	118 127 145 154 166	
			30 36		50 56		52 1/4 58 1/4									50 56			30 36			
	3 1/2	ZNT102308																				
	80 MM	ZNT102080MM	304.80 457.20 609.60		812.80 965.20		869.95 1022.35		111.13	114.30	19.05	50.80	101.06	254.00	298.45	43.66	812.80 965.20	1 1/8-7NC		304.80 457.20	37363.20	535.13 575.95
	85 MM	ZNT102085MM	762.00 914.40		1117.60 1270.00 1422.40		1174.75 1327.15 1479.55										1117.60 1270.00 1422.40		609.60 762.00 914.40		657.58 698.39 752.81	
11	3 11/16	ZNT112311	12 18 24 30	7	36 42 48	2 1/2	38 1/2 44 1/2 50 1/2	5 3/16	5 1/2	3/4	2 1/4	5	12	14 1/2	2 1/16	36 5/16 42 5/16 48 5/16	1 1/4-7NC	6 3/8	12 18 24 30 36	15,600	209 217 249 269 279	
			30 36		54 60		62 1/2									60 5/16			60 5/16			
	3 15/16	ZNT112315																				
	4	ZNT112400																				
	100 MM	ZNT112100MM	304.80 457.20 609.60	177.80	914.40 1066.80	63.50	977.90 1130.30	131.76	139.70	19.05	57.15	127.00	304.80	368.30	52.39	922.35 1074.75	1 1/4-7NC		304.80 457.20	69388.80	947.82 984.10	
		762.00 914.40		1219.20 1371.60 1524.00		1282.70 1435.10 1587.50										1227.15 1379.55 1531.95		609.60 762.00 914.40		1129.22 1219.92 1265.27		

Additional Notes

- Please call 1-866-REXNORD for availability
- Metric bore sizes available, see Rex Interchangeability guide
- Lubrication fitting tap size, 1/8" PT
- Bore size = nominal shaft size +.001 in/-.000 in (+0.03 mm/-0.00 mm)
- Seals - To specify "G", K or M seal, replace "Z" in part number with "G", "K" or "M"
- Auxiliary end caps - available in all size codes
- Allowable working load is 2/3 yield strength

For the Selection Guide, Load Ratings and Speed Limits, see the Spherical Roller Bearings Engineering section on pages 15 - 27.

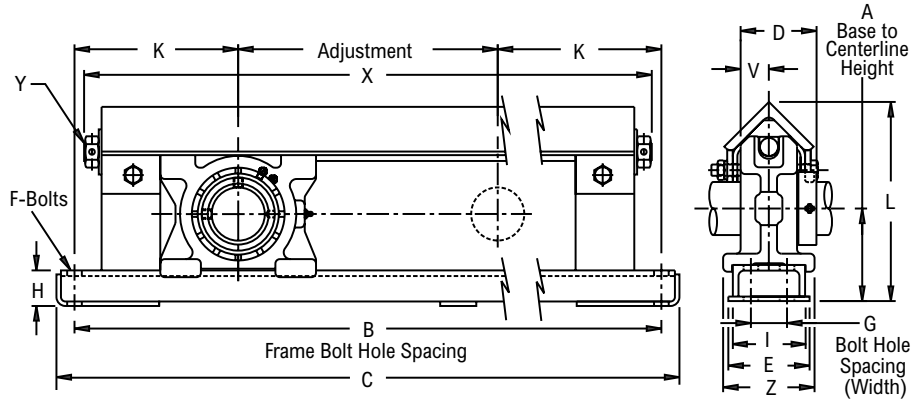
Note: Dimensions subject to change. Certified dimensions of ordered material furnished on request.



Photo Shows a Protected Screw Type Take-up Frame with Spherical Roller Bearing Take-up Unit

Product Features

- Protected screw type frame
- Corrosion-resistant powder coating
- Cast iron housing
- Misalignment capabilities - total of 3°
- Broad range of sealing options
- Factory set clearance & lubrication
- Precision ground & superfinished raceways
- Field interchangeable seals
- See Features and Benefits for additional info on pages 10 - 13.



Bearing Dimensions

Size Code	Shaft Diameter	Complete Take-up Assembly	Travel Length	A Base to Centerline Height	B Frame Bolt Hole Spacing	G Bolt Hole Spacing (Width)	C	D	E	F	H	I	K	L	V	X	Y	Z	Adjust.	Allowable Working Load	Approx. Weight
2-Bolt																					
6	1 15/16	ZNT63115	12	3 15/16	26 1/2	-	28 1/2	3 9/32	3 1/2	5/8	1 3/4	3	7 1/4	8 1/4	1 7/32	25 3/8	3/4-10 NC	3 13/16	12	3,000	45
			18		32 1/2		34 1/2									31 3/8			18		50
			24		38 1/2		40 1/2									37 3/8			24		56
			30		44 1/2		46 1/2									43 3/8			30		63
			36		50 1/2		52 1/2									49 3/8			36		70
7	2 3/16	ZNT73203	12	4 3/16	27 1/2	-	29 1/2	3 1/2	3 1/2	5/8	1 3/4	3	7 3/4	8 11/16	1 9/32	26 3/8	3/4-10 NC	3 13/16	12	3,600	49
			18		33 1/2		35 1/2									32 3/8			18		54
			24		39 1/2		41 1/2									38 3/8			24		66
			30		45 1/2		47 1/2									44 3/8			30		73
			36		51 1/2		53 1/2									50 3/8			36		78
8	2 7/16	ZNT83207	12	4 3/8	28 1/2	-	30 1/2	3 21/32	3 1/2	3/4	1 3/4	3	8 1/4	9 1/8	1 5/16	27 3/4	7/8-9 NC	3 15/16	12	4,400	59
			18		34 1/2		36 1/2									33 3/4			18		63
	24	40 1/2	42 1/2		39 3/4		24									74					
	30	46 1/2	48 1/2		45 3/4		30									79					
	2 1/2	ZNT83208	36		52 1/2		54 1/2								51 3/4			36		85	
4-Bolt																					
9	2 11/16	ZNT93211	12	5 1/8	30 1/2	2	32 1/2	4 13/64	4 1/2	3/4	2	4	9 1/4	10 5/8	1 9/16	30	1-8 NC	5 1/16	12	6,800	85
			18		36 1/2		38 1/2									36			18		93
	24	42 1/2	44 1/2		42		24									113					
	30	48 1/2	50 1/2		48		30									120					
	2 15/16	ZNT93215	36		54 1/2		56 1/2								54			36		128	
10	3 7/16	ZNT103307	12	5 5/8	32	2	34 1/4	4 37/64	4 1/2	3/4	2	4	10	11 3/4	1 23/32	32	1 1/8-7 NC	5 3/16	12	8,400	118
			18		38		40 1/4									38			18		127
	24	44	46 1/4		44		24									145					
	3 1/2	ZNT103308	30		50		52 1/4								50			30		154	
	36		36		56		58 1/4								56			36		166	
11	3 15/16	ZNT113315	12	7	36	2 1/2	38 1/2	5 3/16	5 1/2	3/4	2 1/4	5	12	14 1/2	2 1/16	36 5/16	1 1/4-7 NC	6 3/8	12	15,600	209
			18		42		44 1/2									42 5/16			18		217
			24		48		50 1/2									48 5/16			24		249
			30		54		56 1/2									54 5/16			30		269
			36		60		62 1/2									60 5/16			36		279

Additional Notes

- Please call 1-866-REXNORD for availability
- Lubrication fitting tap size, 1/8" PT
- Bore size = nominal shaft size +.001 in/-.000 in (+0.03 mm/-0.00 mm)
- Seals - To specify G, K or M seal, replace "Z" in part number with "G", "K" or "M"
- Auxiliary end caps - available in all size codes
- Allowable working load is 2/3 yield strength
- For the Selection Guide, Load Ratings and Speed Limits, see the Spherical Roller Bearings Engineering section on pages 15 - 27.

Note: Dimensions subject to change. Certified dimensions of ordered material furnished on request.

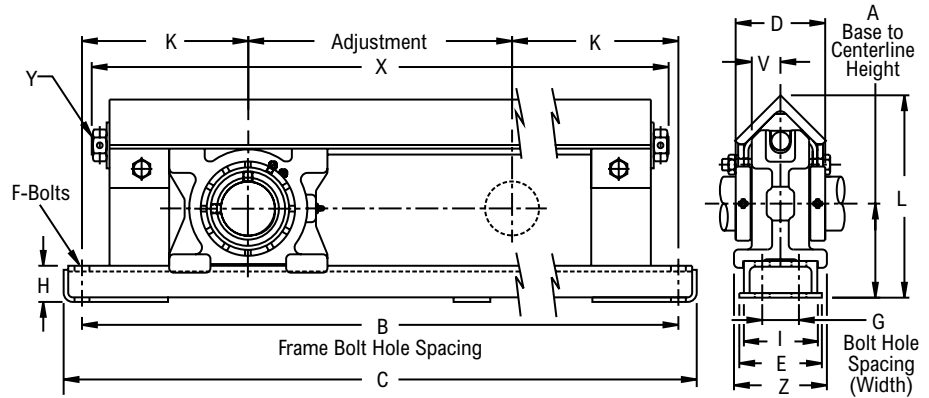
ZNT5000



Photo Shows a Protected Screw Type Take-up Frame with Spherical Roller Bearing Take-up Unit

Product Features

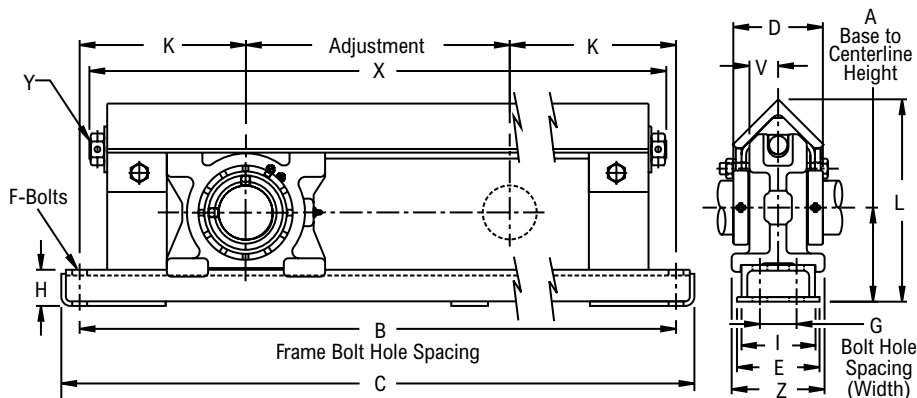
- Protected screw type frame
- Corrosion-resistant powder coating
- Cast iron housing
- Misalignment capabilities - total of 3°
- Broad range of sealing options
- Factory set clearance & lubrication
- Precision ground & superfinished raceways
- Field interchangeable seals
- See Features and Benefits for additional info on pages 10 - 13.



Bearing Dimensions

Size Code	Shaft Diameter	Complete Take-up Assembly	Travel Length	A Base to Centerline Height	B Frame Bolt Hole Spacing	G Bolt Hole Spacing (Width)	C	D	E	F	H	I	K	L	V	X	Y	Z	Adjust.	Allowable Working Load	Approx. Weight
2-Bolt																					
6	1 15/16	ZNT65115	12 18 24 30 36	3 15/16	26 1/2 32 1/2 38 1/2 44 1/2 50 1/2	-	28 1/2 34 1/2 40 1/2 46 1/2 52 1/2	3 13/16	3 1/2	5/8	1 3/4	3	7 1/4	8 1/4	1 7/32	25 3/8 31 3/8 37 3/8 43 3/8 49 3/8	3/4-10 NC	3 13/16	12 18 24 30 36	3,000	47 52 58 65 72
	50 MM	ZNT65050MM	304.80 457.20 609.60 762.00 914.40	100.01	673.10 825.50 977.90 1130.30 1282.70	-	723.90 876.30 1028.70 1181.10 1333.50	46.04	88.90	15.88	44.45	76.20	184.15	209.55	30.96	644.53 796.93 949.33 1101.73 1254.13	3/4-10 NC		304.80 457.20 609.60 762.00 914.40	13344.00	204.08 226.75 253.96 285.71 317.45
7	2	ZNT75200	12 18 24 30 36	4 3/16	27 1/2 33 1/2 39 1/2 45 1/2 51 1/2	-	29 1/2 35 1/2 41 1/2 47 1/2 53 1/2	4 7/8	3 1/2	5/8	1 3/4	3	7 3/4	8 11/16	1 9/32	26 3/8 32 3/8 38 3/8 44 3/8 50 3/8	3/4-10 NC	3 13/16	12 18 24 30 36	3,600	51 56 68 75 80
	55 MM	ZNT75055MM	304.80 457.20 609.60 762.00 914.40	106.36	698.50 850.90 1003.30 1155.70 1308.10	-	749.30 901.70 1054.10 1206.50 1358.90	104.78	88.90	15.88	44.45	76.20	196.85	220.66	32.54	669.93 822.33 974.73 1127.13 1279.53	3/4-10 NC		304.80 457.20 609.60 762.00 914.40	16012.80	231.29 253.96 308.38 340.13 362.80
8	2 7/16	ZNT85207	12 18 24 30 36	4 3/8	28 1/2 34 1/2 40 1/2 46 1/2 52 1/2	-	30 1/2 36 1/2 42 1/2 48 1/2 54 1/2	4 3/8	3 1/2	3/4	1 3/4	3	8 1/4	9 1/8	1 5/16	27 3/4 33 3/4 39 3/4 45 3/4 51 3/4	7/8-9 NC	3 15/16	12 18 24 30 36	4,400	61 65 76 81 87
	60 MM	ZNT85060MM	304.80 457.20 609.60 762.00 914.40	111.13	723.90 876.30 1028.70 1181.10 1333.50	-	774.70 927.10 1079.50 1231.90 1384.30	111.13	88.90	19.05	44.45	76.20	209.55	231.78	33.34	704.85 857.25 1009.65 1162.05 1314.45	7/8-9 NC		304.80 457.20 609.60 762.00 914.40	19751.20	276.64 294.78 344.66 367.34 394.55
9	2 1/2	ZNT95208	12 18 24 30 36	5 1/8	30 1/2 36 1/2 42 1/2 48 1/2 54 1/2	2	32 1/2 38 1/2 44 1/2 50 1/2 56 1/2	4 7/8	4 1/2	3/4	2	4	9 1/4	10 5/8	1 9/16	30 36 42 48 54	1-8 NC	5 1/16	12 18 24 30 36	6,800	87 95 115 122 130
	2 11/16	ZNT95211	12 18 24 30 36	5 1/8	30 1/2 36 1/2 42 1/2 48 1/2 54 1/2	2	32 1/2 38 1/2 44 1/2 50 1/2 56 1/2	4 7/8	4 1/2	3/4	2	4	9 1/4	10 5/8	1 9/16	30 36 42 48 54	1-8 NC	5 1/16	12 18 24 30 36	6,800	87 95 115 122 130

Continued...



Continued...

Bearing Dimensions

Size Code	Shaft Diameter	Complete Take-up Assembly	Travel Length	A Base to Centerline Height	B Frame Bolt Hole Spacing	G Bolt Hole Spacing (Width)	C	D	E	F	H	I	K	L	V	X	Y	Z	Adjust.	Allowable Working Load	Approx. Weight											
4-Bolt (continued)																																
9	70 MM	ZNT95070MM	304.80 457.20 609.60	130.18	774.70 927.10 1079.50	50.80	825.50 977.90 1130.30	123.83	114.30	19.05	50.80	101.60	234.95	269.88	39.69	762.00 914.40 1066.80	1-8NC	304.80 457.20 609.60	30246.40	394.55 430.83 521.53												
		ZNT95075MM	762.00 914.40		1231.90 1384.30		1282.70 1435.10									1219.20 1371.60				762.00 914.40	553.27 589.55											
	75 MM	12 18 24 30 36	32 38 44 50 56		2 2		34 1/4 40 1/4 46 1/4 52 1/4 58 1/4									5 5/16				4 1/2	3/4	2	4	10	11 3/4	1 23/32	32 38 44 50 56	1 1/8-7NC	5 3/16	12 18 24 30 36	8,400	120 129 147 156 168
10	3 3/16	ZNT105303	12 18 24 30 36	5 5/8	32 38 44 50 56	2	34 1/4 40 1/4 46 1/4 52 1/4 58 1/4	5 5/16	4 1/2	3/4	2	4	10	11 3/4	1 23/32	32 38 44 50 56	1 1/8-7NC	5 3/16	12 18 24 30 36	8,400	120 129 147 156 168											
		ZNT105307	30 36		50 56		58 1/4									50 56					762.00 914.40	762.00 914.40	707.46 761.88									
	80 MM	304.80 457.20 609.60	812.80 965.20 1117.60		869.95 1022.35 1174.75		965.20 1117.60 1270.00									812.80 965.20 1117.60 1270.00 1422.40					1 1/8-7NC	304.80 457.20 609.60 762.00 914.40	37363.20	544.20 585.02 666.65 707.46 761.88								
	85 MM	609.60 762.00 914.40	142.88		1117.60 1270.00 1422.40		50.80									1174.75 1327.15 1479.55					134.94	114.30	19.05	50.80	101.06	254.00	298.45	43.66	812.80 965.20 1117.60 1270.00 1422.40	1 1/8-7NC	304.80 457.20 609.60 762.00 914.40	37363.20
11	3 11/16	ZNT115311	12 18 24 30 36	7	36 42 48 54 60	2 1/2	38 1/2 44 1/2 50 1/2 56 1/2 62 1/2	6 1/4	5 1/2	3/4	2 1/4	5	12	14 1/2	2 1/16	36 5/16 42 5/16 48 5/16 54 5/16 60 5/16	1 1/4-7NC	6 3/8	12 18 24 30 36	15,600	211 219 251 271 281											
		ZNT115315	24 30 36		48 54 60		50 1/2 56 1/2 62 1/2									158.75 139.70					19.05	57.15	127.00	304.80	368.30	52.39	922.35 1074.75 1227.15 1379.55 1531.95	1 1/4-7NC	304.80 457.20 609.60 762.00 914.40	69388.80	956.89 993.17 1138.29 1228.99 1274.34	
	ZNT115400	30 36	54 60		62 1/2		1282.70 1435.10 1587.50									158.75					139.70	19.05	57.15	127.00	304.80	368.30	52.39	922.35 1074.75 1227.15 1379.55 1531.95	1 1/4-7NC	304.80 457.20 609.60 762.00 914.40	69388.80	956.89 993.17 1138.29 1228.99 1274.34
	100 MM	304.80 457.20 609.60 762.00 914.40	177.80		914.40 1066.80 1219.20 1371.60 1524.00		63.50									1282.70 1435.10 1587.50					158.75	139.70	19.05	57.15	127.00	304.80	368.30	52.39	922.35 1074.75 1227.15 1379.55 1531.95	1 1/4-7NC	304.80 457.20 609.60 762.00 914.40	69388.80

Additional Notes

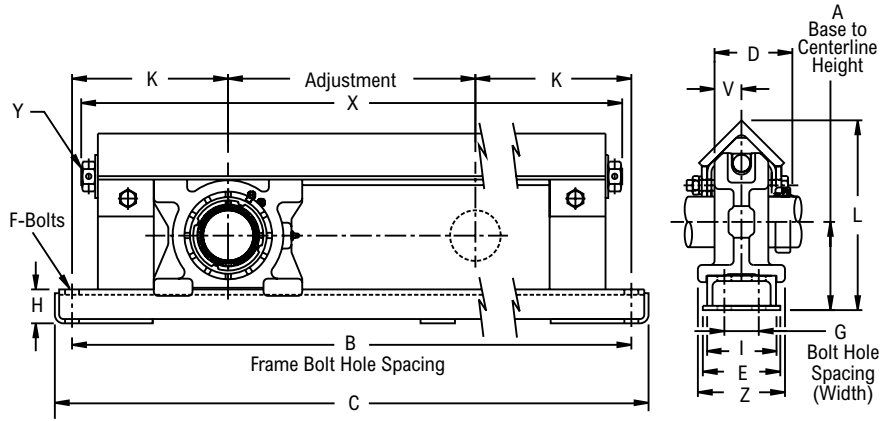
Please call 1-866-REXNORD for availability
 Metric bore sizes available, see Rex Interchangeability guide
 Lubrication fitting tap size, 1/8" PT
 Bore size = nominal shaft size +.001 in/-.000 in (+0.03 mm/-0.00 mm)
 Seals - To specify G, K or M seal, replace "Z" in part number with "G", "K" or "M"
 Auxiliary end caps - available in all size codes
 Allowable working load is 2/3 yield strength

For the Selection Guide, Load Ratings and Speed Limits, see the Spherical Roller Bearings Engineering section on pages 15 - 27.
 Note: Dimensions subject to change. Certified dimensions of ordered material furnished on request.

ZNT6000



Photo Shows a Protected Screw Type Take-up Frame with Spherical Roller Bearing Take-up Unit



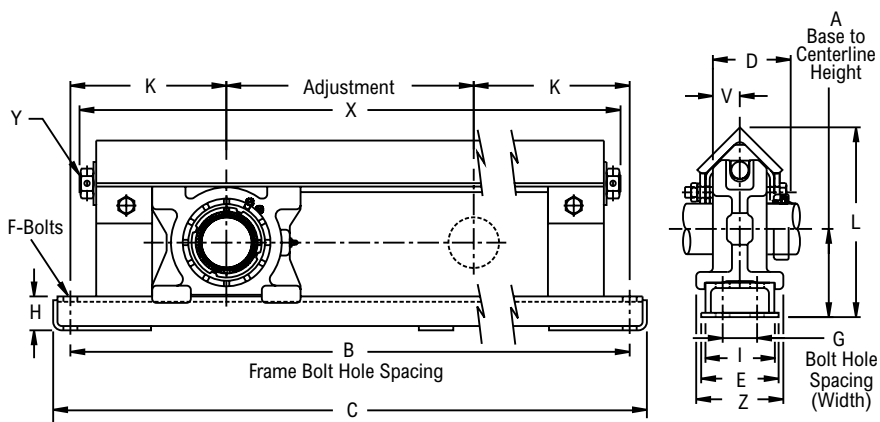
Product Features

- Spyglass Optical Strain Sensor (OSS) Technology
- Positive locking system
- Tapered adapter sleeve
- Protected screw type frame
- Corrosion-resistant powder coating
- Cast iron housing
- Misalignment capabilities - total of 3°
- Broad range of sealing options
- Factory set clearance & lubrication
- See Features and Benefits for additional info on pages 10 - 13.

Bearing Dimensions

Size Code	Shaft Diameter	Complete Take-up Assembly	Travel Length	A Base to Centerline Height	B Frame Bolt Hole Spacing	G Bolt Hole Spacing (Width)	C	D	E	F	H	I	K	L	V	X	Y	Z	Adjust.	Allowable Working Load	Approx. Weight														
2-Bolt																																			
6	1 15/16	ZNT66115	12 18 24 30 36	3 15/16	26 1/2 32 1/2 38 1/2 44 1/2 50 1/2	-	28 1/2 34 1/2 40 1/2 46 1/2 52 1/2	3 41/64	3 1/2	5/8	1 3/4	3	7 1/4	8 1/4	1 7/32	25 3/8 31 3/8 37 3/8 43 3/8 49 3/8	3/4-10 NC	3 13/16	12 18 24 30 36	3,000	47 52 58 65 72														
	45 MM	ZNT66045MM	304.80 457.20 609.60 762.00 914.40	100.01	673.10 825.50 977.90 1130.30 1282.70	-	723.90 876.30 1028.70 1181.10 1333.50	92.47	88.90	15.88	44.45	76.20	184.15	209.55	30.96	644.53 796.93 949.33 1101.73 1254.13	3/4-10 NC		304.80 457.20 609.60 762.00 914.40	13,344.00	204.08 226.75 253.96 285.71 317.45														
7	2 3/16	ZNT76203	12 18 24 30 36	4 3/16	27 1/2 33 1/2 39 1/2 45 1/2 51 1/2	-	29 1/2 35 1/2 41 1/2 47 1/2 53 1/2	3 49/64	3 1/2	5/8	1 3/4	3	7 3/4	8 11/16	1 9/32	26 3/8 32 3/8 38 3/8 44 3/8 50 3/8	3/4-10 NC	3 13/16	12 18 24 30 36	3,600	51 56 68 75 80														
	55 MM	ZNT76055MM	304.80 457.20 609.60 762.00 914.40	106.36	698.50 850.90 1003.30 1155.70 1308.10	-	749.30 901.70 1054.10 1206.50 1358.90	95.65	88.90	15.88	44.45	76.20	196.85	220.66	32.54	669.93 822.33 974.73 1127.13 1279.53	3/4-10 NC		304.80 457.20 609.60 762.00 914.40	16,012.80	231.29 253.96 308.38 340.13 362.80														
8	2 3/8	ZNT86206	12 18 24 30 36	4 3/8	28 1/2 34 1/2 40 1/2 46 1/2 52 1/2	-	30 1/2 36 1/2 42 1/2 48 1/2 54 1/2	4 5/32	3 1/2	3/4	1 3/4	3	8 1/4	9 1/8	1 5/16	27 3/4 33 3/4 39 3/4 45 3/4 51 3/4	7/8-9 NC	3 15/16	12 18 24 30 36	4,400	61 65 76 81 87														
	60 MM	ZNT86060MM	304.80 457.20 609.60 762.00 914.40	111.13	723.90 876.30 1028.70 1181.10 1333.50	-	774.70 927.10 1079.50 1231.90 1384.30	105.57	88.90	19.05	44.45	76.20	209.55	231.78	33.34	704.85 857.25 1009.65 1162.05 1314.45	7/8-9 NC		304.80 457.20 609.60 762.00 914.40	19,751.20	276.64 294.78 344.66 367.34 394.55														
4-Bolt																																			
9	2 11/16	ZNT96211	12 18 24 30 36	5 1/8	30 1/2 36 1/2 42 1/2 48 1/2 54 1/2	2	32 1/2 38 1/2 44 1/2 50 1/2 56 1/2	4 17/32	4 1/2	3/4	2	4	9 1/4	10 5/8	1 9/16	30 36 42 48 54	1-8 NC	5 1/16	12 18 24 30 36	6,800	87 95 115 122 130														
	2 3/4	ZNT96212																																	
	2 15/16	ZNT96215																																	

Continued...



Continued...

Bearing Dimensions

Size Code	Shaft Diameter	Complete Take-up Assembly	Travel Length	A Base to Centerline Height	B Frame Bolt Hole Spacing	G Bolt Hole Spacing (Width)	C	D	E	F	H	I	K	L	V	X	Y	Z	Adjust.	Allowable Working Load	Approx. Weight
4-Bolt (continued)																					
9	70 MM	ZNT96070MM	304.80 457.20 609.60 762.00 914.40	130.18	774.70 927.10	50.80	825.50 977.90	1130.30	115.09	114.30	19.05	50.80	101.60	234.95	269.88	39.69	762.00 914.40	1-8NC	304.80 457.20	30,246.40	394.55 430.83
	75 MM	ZNT95075MM	609.60 762.00 914.40		1079.50 1231.90 1384.30		1174.75 1327.15 1435.10										1229.20 1371.60		269.88 39.69		521.53 553.27 589.55
10	3 ^{3/16}	ZNT106303	12 18 24 30 36	5 ^{5/8}	32 38	2	34 1/4 40 1/4	5 ^{9/64}	4 1/2	3/4	2	4	10	11 3/4	1 ^{23/32}	32 38	1 1/8-7NC	5 ^{3/16}	12 18	8,400	120 129
		ZNT106307	30 36		44 50 56		46 1/4 52 1/4 58 1/4									44 50 56			24 30 36		147 156 168
	80 MM	ZNT106080MM	304.80 457.20 609.60 762.00 914.40	142.88	812.80 965.20	50.80	869.95 1022.35	130.57	114.30	19.05	50.80	101.06	254.00	298.45	43.66	812.80 965.20	1 1/8-7NC	304.80 457.20	37,363.20	544.20 585.02	
	85 MM	ZNT106085MM	609.60 762.00 914.40		1117.60 1270.00 1422.40		1174.75 1327.15 1479.55									1270.00 1422.40		298.45 43.66		666.65 707.46 761.88	
11	3 ^{11/16}	ZNT116311	12 18 24 30 36	7	36 42 48	2 1/2	38 1/2 44 1/2	5 ^{31/32}	5 1/2	3/4	2 1/4	5	12	14 1/2	2 1/16	36 5/16 42 5/16	1 1/4-7NC	6 ^{3/8}	12 18	15,600	211 219
		ZNT116315	30 36		54 60		50 1/2 56 1/2 62 1/2									48 54 60			24 30 36		251 271 281
	90 MM	ZNT116090MM	304.80 457.20 609.60 762.00 914.40	177.80	914.40 1066.80	63.50	977.90 1130.30	151.61	139.70	19.05	57.15	127.00	304.80	368.30	52.39	922.35 1074.75	1 1/4-7NC	304.80 457.20	69,388.80	956.89 993.17	
	100 MM	ZNT116100MM	609.60 762.00 914.40		1219.20 1371.60 1524.00		1282.70 1435.10 1587.50									1379.55 1531.95		1138.29 1228.99 1274.34			

Additional Notes

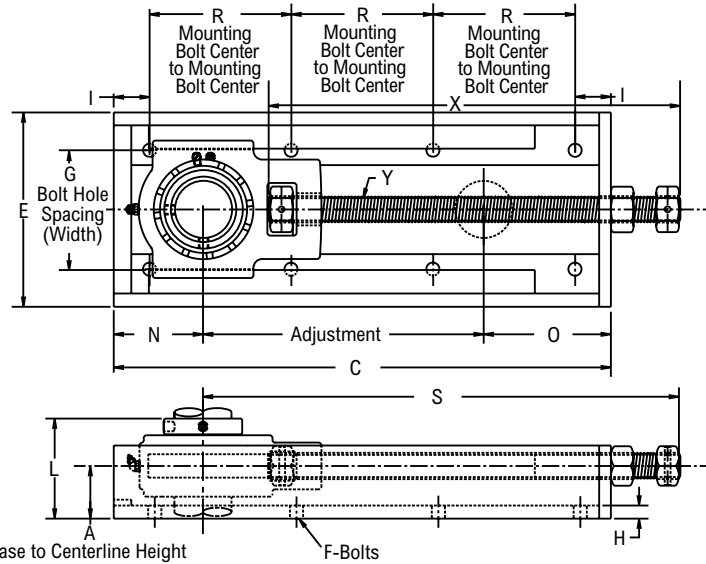
Please call 1-866-REXNORD for availability
 Lubrication fitting tap size, 1/8" PT
 Bore size = nominal shaft size +.001 in/-.000 in (+0.03 mm/-0.00 mm)
 Seals - To specify G, K or M seal, replace "Z" in part number with "G", "K" or "M"
 Auxiliary end caps - available in all size codes
 Allowable working load is 2/3 yield strength
 For the Selection Guide, Load Ratings and Speed Limits, see the Spherical Roller Bearings Engineering section on pages 15 - 27.

Note: Dimensions subject to change. Certified dimensions of ordered material furnished on request.

ZAT2000



Photo Shows a Center Pull, Side Mounted Take-up Frame with Spherical Roller Bearing Take-up Unit



Product Features

- Center pull side mounted frame
- Corrosion-resistant powder coating
- Cast iron housing
- Misalignment capabilities - total of 3°
- Broad range of sealing options
- Factory set clearance & lubrication
- Precision ground & superfinished raceways
- Field interchangeable seals
- See Features and Benefits for additional info on pages 10 - 13.

Bearing Dimensions

Size Code	Shaft Diameter	Part Number	Adjust.	A Base to Centerline Height	G Bolt Hole Spacing (Width)	R Mounting Bolt Center to Mounting Bolt Center	C	E	F	H	I	L	N	O	S	X	Y	Approx. Weight
6-Bolt																		
4	1 7/16	ZAT421079	9	1 7/8	3 9/16	6 7/16	15 7/8	5 3/16	1/2	3/16	1 1/2	3 5/8	3	3 7/8	15	13 1/8	3/4-10 NC	18.40
	35.00	ZAT42035MM9	228.60	47.63	90.49	163.51	403.23	131.76	13.00	4.75	38.10	92.08	76.20	98.43	381.00	333.38	3/4-10 NC	8.30
5	1 11/16	ZAT521119	9	2	4 1/16	7	17	5 13/16	1/2	1/4	1 1/2	3 7/8	3 1/4	4 3/4	16	13 1/2	7/8-9 NC	26.80
	40.00	ZAT52040MM9	228.60	50.80	103.19	177.80	431.80	147.64	13.00	6.35	38.10	98.43	82.55	120.65	406.40	342.90	7/8-9 NC	12.20
	45.00	ZAT52045MM9																
6	1 15/16	ZAT621159	9	2	4 1/16	7	17	5 13/16	1/2	1/4	1 1/2	3 7/8	3 1/4	4 3/4	16	13 1/2	7/8-9 NC	27.10
	50.00	ZAT62050MM9	228.60	50.80	103.19	177.80	431.80	147.64	13.00	6.35	38.10	98.43	82.55	120.65	406.40	342.90	7/8-9 NC	12.30
7	2 3/16	ZAT722039	9	2	4 13/16	7 1/2	18	6 9/16	1/2	1/4	1 1/2	4	3 9/16	5 7/16	16 15/16	14 5/16	1-8 NC	33.70
	55.00	ZAT72055MM9	228.60	50.80	122.24	190.50	457.20	166.69	13.00	6.35	38.10	101.60	90.49	138.11	176.21	363.54	1-8 NC	15.30
8-Bolt																		
8	2 7/16	ZAT8220712	12	2 1/4	5 1/16	6 1/16	21 11/16	7 5/16	1/2	5/16	1 3/4	4 7/16	3 13/16	5 7/8	20 3/4	18	1 1/8-7 NC	51.00
	60.00	ZAT82060MM12	304.80	57.15	128.59	153.99	550.86	185.74	13.00	7.94	44.45	112.71	96.84	149.23	527.05	457.20	1 1/8-7 NC	23.20
	65.00	ZAT82065MM12																
9	2 15/16	ZAT9221512	12	2 7/16	5 3/8	6 1/2	23	8 1/8	1/2	5/16	1 3/4	4 7/8	4 1/4	6 3/4	21 3/4	18 1/2	1 1/4-7 NC	75.00
	70.00	ZAT92070MM12	304.80	61.91	136.53	165.10	584.20	206.38	13.00	7.94	44.45	123.83	107.95	171.45	552.45	469.90	1 1/4-7 NC	34.00
	75.00	ZAT92075MM12																

Additional Notes

- Please call 1-866-REXNORD for availability
- Metric bore sizes available, see Rex Interchangeability guide
- Lubrication fitting tap size, 1/8" PT
- Bore size = nominal shaft size +.001 in/-.000 in (+0.03 mm/-0.00 mm)
- Seals - To specify G, K or M seal, replace "Z" in part number with "G", "K" or "M"
- Auxiliary end caps - available in all size codes on outboard side only
- For the Selection Guide, Load Ratings and Speed Limits, see the Spherical Roller Bearings Engineering section on pages 15 - 27.

Note: Dimensions subject to change. Certified dimensions of ordered material furnished on request.

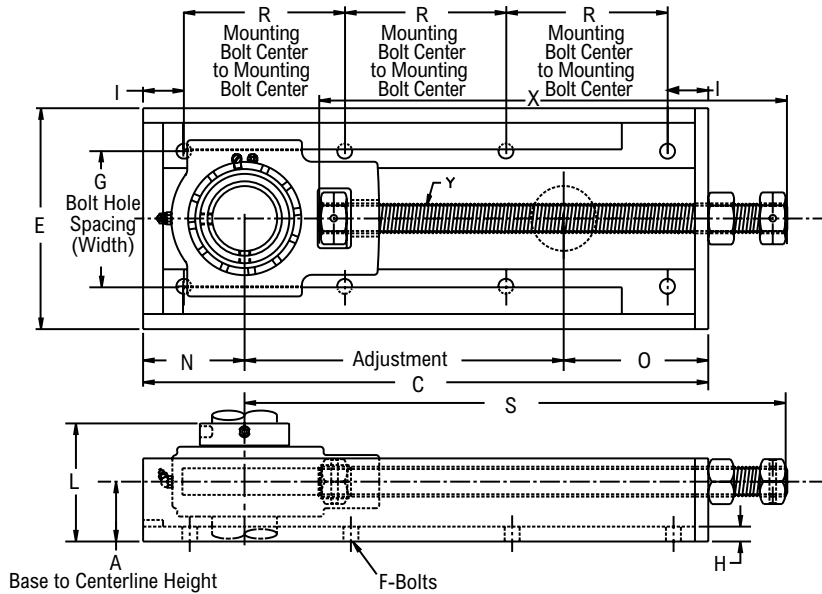
ZAT3000



Photo Shows a Center Pull, Side Mounted Take-up Frame with Spherical Roller Bearing Take-up Unit

Product Features

- Center pull side mounted frame
- Corrosion-resistant powder coating
- Cast iron housing
- Misalignment capabilities - total of 3°
- Broad range of sealing options
- Factory set clearance & lubrication
- Precision ground & superfinished raceways
- Field interchangeable seals
- See Features and Benefits for additional info on pages 10 - 13.



Bearing Dimensions

Size Code	Shaft Diameter	Part Number	Adjust.	A Base to Centerline Height	G Bolt Hole Spacing (Width)	R Mounting Bolt Center to Mounting Bolt Center	C	E	F	H	I	L	N	O	S	X	Y	Approx. Weight
6-Bolt																		
4	1 7/16	ZAT431079	9	1 7/8	3 9/16	6 7/16	15 7/8	5 3/16	1/2	3/16	1 1/2	3 5/8	3	3 7/8	15	13 1/8	3/4-10 NC	18.40
5	1 11/16	ZAT531119	9	2	4 1/16	7	17	5 13/16	1/2	1/4	1 1/2	3 7/8	3 1/4	4 3/4	16	13 1/2	7/8-9 NC	26.80
6	1 15/16	ZAT631159	9	2	4 1/16	7	17	5 13/16	1/2	1/4	1 1/2	3 7/8	3 1/4	4 3/4	16	13 1/2	7/8-9 NC	27.10
7	2 3/16	ZAT732039	9	2	4 13/16	7 1/2	18	6 9/16	1/2	1/4	1 1/2	4	3 9/16	5 7/16	16 15/16	14 5/16	1-8 NC	33.70
8-Bolt																		
8	2 7/16	ZAT8320712	12	2 1/4	5 1/16	6 1/16	21 11/16	7 5/16	1/2	5/16	1 3/4	4 7/16	3 13/16	5 7/8	20 3/4	18	1 1/8-7 NC	51.00
9	2 15/16	ZAT9321512	12	2 7/16	5 3/8	6 1/2	23	8 1/8	1/2	5/16	1 3/4	4 7/8	4 1/4	6 3/4	21 3/4	18 1/2	1 1/4-7 NC	75.00

Additional Notes

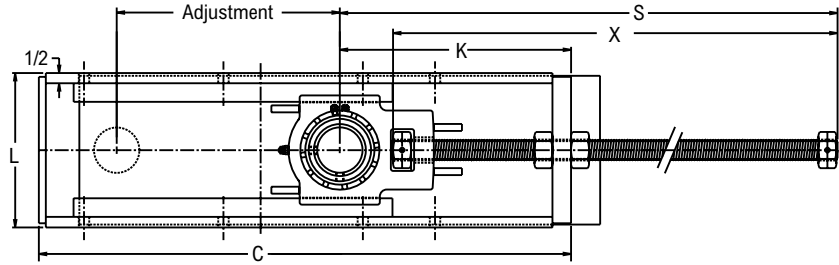
- Please call 1-866-REXNORD for availability
- Lubrication fitting tap size, 1/8" PT
- Bore size = nominal shaft size +.001 in/-.000 in (+0.03 mm/-0.00 mm)
- Seals - To specify G, K or M seal, replace "Z" in part number with "G", "K" or "M"
- Auxiliary end caps - available in all size codes on outboard side only
- For the Selection Guide, Load Ratings and Speed Limits, see the Spherical Roller Bearings Engineering section on pages 15 - 27.

Note: Dimensions subject to change. Certified dimensions of ordered material furnished on request.

ZFT5000

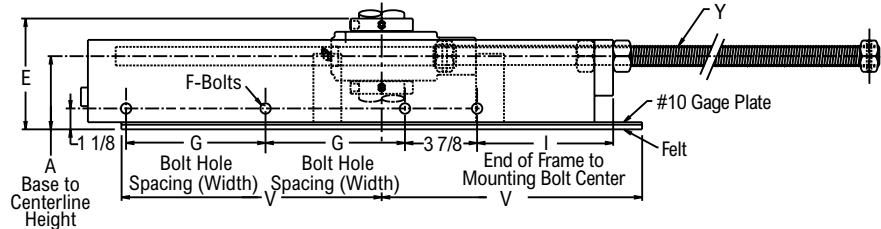


Photo Shows an Elevator Boot Take-up Frame with Spherical Roller Bearing Take-up Unit



Product Features

- Center pull elevator boot frame
- Back plate makes casing dust tight
- Corrosion-resistant powder coating
- Cast iron housing
- Misalignment capabilities - total of 3°
- Broad range of sealing options
- Factory set clearance & lubrication
- Precision ground & superfinished raceways
- Field interchangeable seals
- See Features and Benefits for additional info on pages 10 - 13.



Bearing Dimensions

Size Code	Shaft Diameter	Part Number	A Base to Centerline Height	G Bolt Hole Spacing (Width)	I End of Frame at Rod End to Mounting Bolt Center	C	E	F	K	L	S	V	X	Y	Adjust.	Approx. Weight
6	1 15/16	ZFT651159	3 11/16	6	5 1/2	23 1/2	5 5/8	1/2	10 5/8	7 3/16	21 3/4	11	19 1/2	7/8-9 NC	9	63.00
	50.00	ZFT65050MM9	93.66	152.40	139.70	596.90	142.88	13.00	269.88	182.56	21.75	279.40	495.30	7/8-9 NC	228.60	28.60
8	2 7/16	ZFT8520712	3 15/16	7 1/2	7 5/16	28 5/8	6 1/8	1/2	12 7/16	8 5/16	27	14	24 1/4	1 1/8-7 NC	12	88.00
	60.00	ZFT85060MM12	100.01	190.50	185.74	727.08	155.58	13.00	315.91	211.14	685.80	355.60	615.95	1 1/8-7 NC	304.80	40.00
	65.00	ZFT85065MM12														
9	2 1/2	ZFT9520812	4 3/8	7 1/2	8 3/4	30 3/8	6 13/16	1/2	13 7/8	8 5/8	28 5/8	14	25 3/8	1 1/4-7 NC	12	117.00
	2 11/16	ZFT9521112														115.00
	2 15/16	ZFT9521512	111.13	190.50	222.25	771.53	173.04	13.00	352.43	219.08	727.08	355.60	593.73	1 1/8-7 NC	304.80	114.00
	70.00	ZFT95070MM12														52.10
	75.00	ZFT95075MM12														51.80

Additional Notes

- Please call 1-866-REXNORD for availability
- Metric bore sizes available, see Rex Interchangeability guide
- Lubrication fitting tap size, 1/8" PT
- Bore size = nominal shaft size +.001 in/-.000 in (+0.03 mm/-0.00 mm)
- Seals - To specify G, K or M seal, replace "Z" in part number with "G", "K" or "M"
- Auxiliary end caps - available in all size codes
- For the Selection Guide, Load Ratings and Speed Limits, see the Spherical Roller Bearings Engineering section on pages 15 - 27.

Note: Dimensions subject to change. Certified dimensions of ordered material furnished on request.

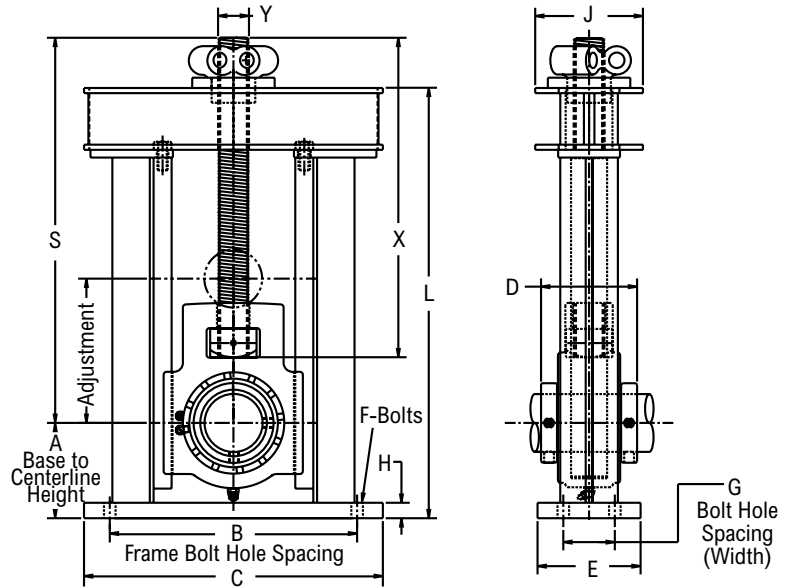
ZGT5000



Photo Shows an Elevator Head Take-up Frame with Spherical Roller Bearing Take-up Unit

Product Features

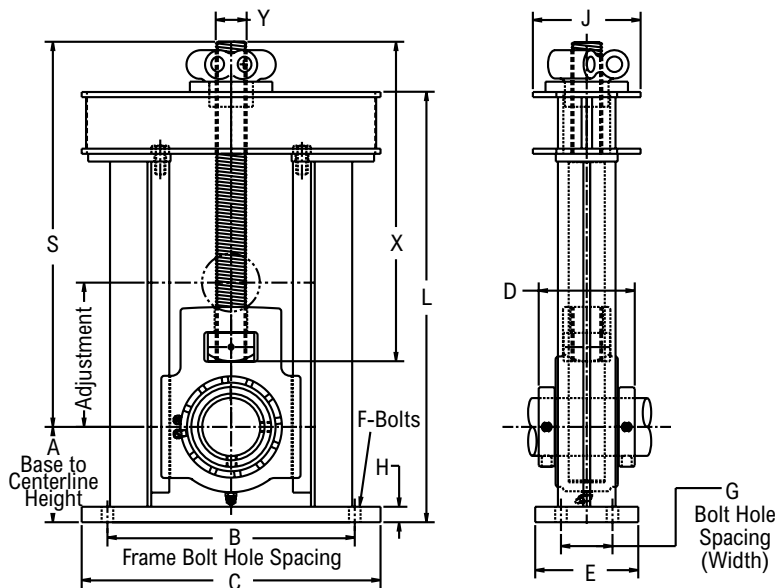
- Center pull elevator head frame
- Corrosion-resistant powder coating
- Cast iron housing
- Misalignment capabilities - total of 3°
- Broad range of sealing options
- Factory set clearance & lubrication
- Precision ground & superfinished raceways
- Field interchangeable seals
- See Features and Benefits for additional info on pages 10 - 13.



Bearing Dimensions

Size Code	Shaft Diameter	Part Number	A Base to Centerline Height	B Frame Bolt Hole Spacing	G Bolt Hole Spacing (Width)	C	D	E	F	H	J	L	S	X	Y	Adjust.	Allowable Working Load	Approx. Weight															
6	1 15/16	ZGT651156	3 5/16	10	1 3/4	12	3 13/16	3 1/2	1/2	1/2	4 15/16	16 1/2	15 7/8	13 5/8	1-8 NC	6	12,300	50.00															
	50.00	ZGT65050MM6	84.14	254.00	44.45	304.80	96.84	88.90	13.00	12.70	125.41	419.10	403.23	346.08	1-8 NC	152.40	5,580	22.70															
8	2 7/16	ZGT852077	4 1/8	11	2	13 1/2	4 3/8	4	5/8	3/4	4 15/16	19 7/16	18 3/4	13 5/8	1 1/4-7 NC	7	20,900	74.00															
	60.00	ZGT85060MM7	104.78	279.40	50.80	342.90	111.13	101.60	16.00	19.05	125.41	493.70	476.25	346.08	1 1/4-7 NC	177.80	9,480	33.50															
9	2 1/2	ZGT952087	4 5/8	12	2 1/2	14 1/2	4 7/8	5	5/8	3/4	5 1/4	20 7/8	17 7/8	15 1/2	1 1/2-6 NC	7	26,800	103.00															
	2 11/16	ZGT952117																101.00															
	2 9/16	ZGT952157																100.00															
	70.00	ZGT95070MM7																117.48	304.80	63.50	368.30	123.83	127.00	16.00	19.05	133.35	530.23	454.03	393.70	1 1/2-6 NC	177.80	12,100	45.80
75.00	ZGT95075MM7	117.48	304.80	63.50	368.30	123.83	127.00	16.00	19.05	133.35	530.23	454.03	393.70	1 1/2-6 NC	177.80	12,100	44.80																
10	3 3/16	ZGT10530310	5 1/8	13	3	16	5 5/16	5	3/4	3/4	6	25 1/16	23 3/16	19 1/2	1 3/4-5 NC	10	27,300	140.00															
	3 7/16	ZGT10530710																138.00															
	80.00	ZGT105080MM10																130.18	330.20	76.20	406.40	134.94	127.00	19.00	19.05	152.40	636.59	588.96	495.30	1 3/4-5 NC	254.00	12,400	64.00
	85.00	ZGT105085MM10																130.18	330.20	76.20	406.40	134.94	127.00	19.00	19.05	152.40	636.59	588.96	495.30	1 3/4-5 NC	254.00	12,400	63.50
90.00	ZGT105090MM10	130.18	330.20	76.20	406.40	134.94	127.00	19.00	19.05	152.40	636.59	588.96	495.30	1 3/4-5 NC	254.00	12,400	63.00																
11	3 11/16	ZGT11531110	5 13/16	14	3	17	6 1/8	5	3/4	3/4	8 1/4	27 3/4	26 7/16	22	2-4 1/2 NC	10	45,400	214.00															
	3 15/16	ZGT11531510																211.00															
	4	ZGT11540010																210.00															
	100.00	ZGT115100MM10																147.64	355.60	76.20	431.80	155.58	127.00	19.00	19.05	209.55	704.85	671.51	558.80	1 3/4-5 NC	254.00	20,600	96.00
4 7/16	ZGT125407Y10	6 13/16	17	3 1/2	20	6 1/4	6	7/8	3/4	9 1/4	32 1/4	29 1/2	24 1/2	2-4 1/2 NC	10 1/2	53,700	260.00																
110.00	ZGT125110MM10	173.16	431.80	88.90	508.00	158.75	152.40	22.00	19.05	234.95	819.15	749.30	622.30	2-4 1/2 NC	266.70	24,300	118.00																
115.00	ZGT125115MM10	173.16	431.80	88.90	508.00	158.75	152.40	22.00	19.05	234.95	819.15	749.30	622.30	2-4 1/2 NC	266.70	24,300	117.00																
13	4 15/16	ZGT13541510	7 3/16	18	3 1/2	21	7 7/8	6	7/8	3/4	9 7/16	34 5/8	31 3/4	26 5/16	2 1/4-4 1/2 NC	10 1/2	68,000	329.00															
	5	ZGT13550010																326.00															
	125.00	ZGT135125MM10																182.56	457.20	88.90	533.40	200.03	152.40	22.00	19.05	239.71	879.48	806.45	668.34	2-4 1/2 NC	266.70	30,800	149.00
130.00	ZGT135130MM10	182.56	457.20	88.90	533.40	200.03	152.40	22.00	19.05	239.71	879.48	806.45	668.34	2-4 1/2 NC	266.70	30,800	148.00																
14	5 7/16	ZGT14550710	9 11/16	23	7	31	8	10	1 1/8	1	10 1/2	44 7/8	42 1/4	35	3-4 NC	10 1/2	125,000	1,200.00															
	140.00	ZGT145140MM10	246.06	584.20	177.80	787.40	203.20	254.00	28.00	25.40	266.70	1,139.83	1,073.15	889.00	2 1/4-4 1/2 NC	266.70	56,200	545.00															
15	5 15/16	ZGT15551510	9 11/16	23	7	31	8 1/8	10	1 1/8	1	10 1/2	44 7/8	42 1/4	35	3-4 NC	10 1/2	125,000	1,200.00															
	6	ZGT15560010																1,200.00															
	150.00	ZGT155150MM10																246.06	584.20	177.80	787.40	206.38	254.00	28.00	25.40	266.70	1,139.83	1,073.15	889.00	3-4 NC	266.70	56,200	545.00
	160.00	ZGT155160MM10																246.06	584.20	177.80	787.40	206.38	254.00	28.00	25.40	266.70	1,139.83	1,073.15	889.00	3-4 NC	266.70	56,200	545.00
16	6 7/16	ZGT16560710	9 11/16	23	7	31	8 3/4	10	1 1/8	1	10 1/2	44 7/8	42 1/4	35	3-4 NC	10 1/2	125,000	1,200.00															
	6 15/16	ZGT16561510																1,200.00															

Continued...



Continued...

Bearing Dimensions

Size	Shaft Diameter	Part Number	A Base to Centerline Height	B Frame Bolt Hole Spacing	G Bolt Hole Spacing (Width)	C	D	E	F	H	J	L	S	X	Y	Adjust.	Allowable Working Load	Approx. Weight
16	7	ZGT16570010	9 11/16	23	7	31	8 3/4	10	1 1/8	1	10 1/2	44 7/8	42 1/4	35	3-4 NC	10 1/2	125,000	1,200.00
	180.00	ZGT165180MM10	246.06	584.20	177.80	787.40	222.25	254.00	28.00	25.40	266.70	1,139.83	1,073.15	889.00	3-4 NC	266.70	56,200	545.00

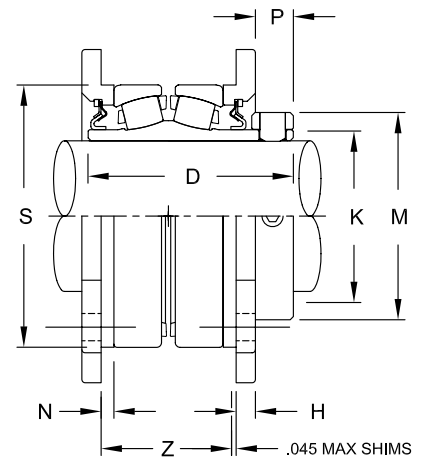
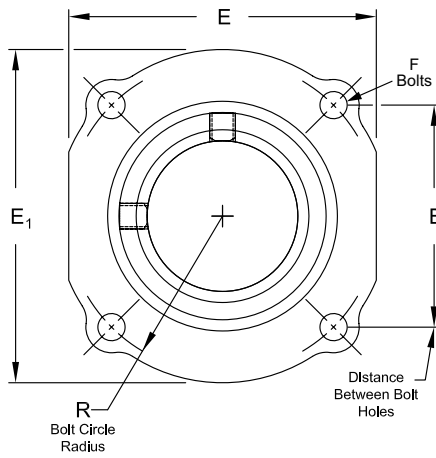
Additional Notes

- Please call 1-866-REXNORD for availability
- Metric bore sizes available, see Rex Interchangeability guide
- Lubrication fitting tap size, 1/8" PT
- Bore size = nominal shaft size +.001 in/-.000 in (+0.03 mm/-0.00 mm)
- Seals - To specify G, K or M seal, replace "Z" in part number with "G", "K" or "M"
- "G" seals available in size codes 6 thru 13
- "K" seals available in size codes 6 thru 11

- Auxiliary end caps - available in all size codes
- Allowable working load is 2/3 yield strength
- For the Selection Guide, Load Ratings and Speed Limits, see the Spherical Roller Bearings Engineering section on pages 15 - 27.
- Note: Dimensions subject to change. Certified dimensions of ordered material furnished on request.



Photo Shows a Spherical Roller Bearing Duplex Unit



Product Features

- Corrosion-resistant powder coating
- Cast iron housing
- Misalignment capabilities - total of 4°
- Broad range of sealing options
- Factory set clearance & lubrication
- Precision ground & superfinished raceways
- Hardened spring locking collar
- Field interchangeable seals
- See Features and Benefits for additional info on pages 10 - 13.

Bearing Dimensions

Size Code	Shaft Diameter	Part Number	B Distance Between Bolt Holes	R Bolt Circle Radius	D	E1	E	F	H	K	M	N	P	S	Z	Recommended Housing Bore Diameter	Approx. Weight
4	1 7/16	ZD2107	2 9/16	1 13/16	2 7/8	3 3/4	3 5/16	3/8	5/16	1 3/4	2 5/16	7/32	5/8	2.8380	1.725	2.8360	3.00
	1 1/2	ZD2108															2.90
5	35.00	ZD2035MM	2 7/8	2 1/32	3 1/8	4 1/4	3 3/4	3/8	5/16	2 1/32	2 19/32	3/16	5/8	3.3500	1.930	3.3480	4.20
	1 11/16	ZD2111															4.00
	1 3/4	ZD2112															2.00
	40.00	ZD2040MM															1.90
6	45.00	ZD2045MM	73.02	15.59	79.38	107.95	95.25	10.00	7.94	26.190	65.88	5.02	15.88	85.0900	49.022	85.0392	4.60
	1 15/16	ZD2115															4.50
	2	ZD2200															2.10
7	50.00	ZD2050MM	76.20	59.98	79.38	114.30	101.60	10.00	7.94	58.740	73.03	5.02	16.66	90.0938	47.625	90.0430	6.20
	2 3/16	ZD2203															6.10
	2 1/4	ZD2204															2.80
8	55.00	ZD2055MM	85.52	61.11	84.14	130.18	115.89	11.00	7.94	66.680	82.55	3.18	17.45	100.0760	47.752	86.1822	7.80
	2 3/8	ZD2206															7.70
	2 7/16	ZD2207															7.50
	2 1/2	ZD2208															3.50
	60.00	ZD2060MM															3.30
9	65.00	ZD2065MM	94.43	66.68	88.90	139.70	125.41	13.00	7.94	73.810	90.49	6.35	19.05	110.0836	56.515	110.0328	13.30
	2 11/16	ZD2211															13.10
	2 3/4	ZD2212															12.10
	2 15/16	ZD2215															11.60
	70.00	ZD2070MM															6.00
10	75.00	ZD2075MM	109.93	77.79	101.60	165.10	152.40	13.00	9.53	85.730	103.19	6.35	19.05	130.0480	66.040	130.0226	5.80
	3 3/16	ZD2303															18.70
	3 7/16	ZD2307															17.20
	3 1/2	ZD2308															16.80
	80.00	ZD2080MM															18.50
11	85.00	ZD2085MM	125.80	88.90	111.13	187.33	173.04	16.00	11.11	100.810	124.62	5.02	22.23	105.0632	67.666	150.0124	18.10
	90.00	ZD2090MM															17.80
	3 11/16	ZD2311															35.50
	3 15/16	ZD2315															31.20
	100.00	ZD2100MM															14.20

Additional Notes

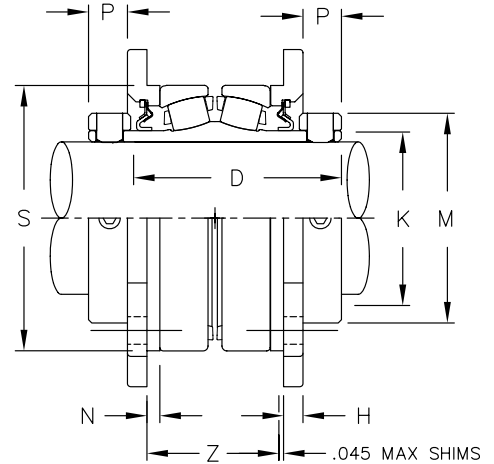
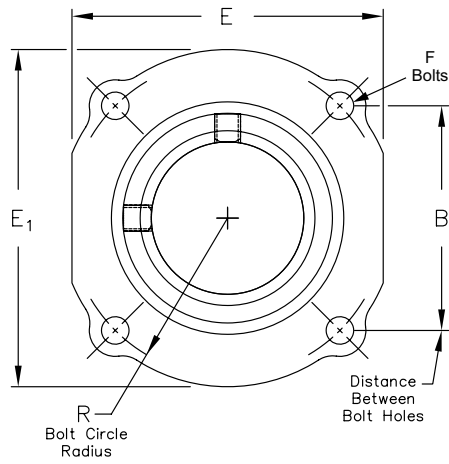
- Please call 1-866-REXNORD for availability
- Metric bore sizes available, see Rex Interchangeability guide
- Bore size = nominal shaft size +.001 in/-.000 in (+0.03 mm/-0.00 mm)
- Outer race O.D. tolerance, +.000"/-.001" (-0.00 mm/+0.03 mm)
- Recommended housing bore diameter tolerance, +.002"/-.000" (+0.05 mm/-0.00 mm)
- Seals - To specify G, K or M seal, replace "Z" in part number with "G", "K" or "M"
- Auxiliary end caps - not available

For the Selection Guide, Load Ratings and Speed Limits, see the Spherical Roller Bearings Engineering section on pages 15 - 27.
 Note: Dimensions subject to change. Certified dimensions of ordered material furnished on request.

ZD5000



Photo Shows a Spherical Roller Bearing Duplex Unit



Product Features

- Corrosion-resistant powder coating
- Cast iron housing
- Misalignment capabilities - total of 4°
- Broad range of sealing options
- Factory set clearance & lubrication
- Precision ground & superfinished raceways
- Two hardened spring locking collars
- Field interchangeable seals
- See Features and Benefits for additional info on pages 10 - 13.

Bearing Dimensions

Size Code	Shaft Diameter	Part Number	B Distance Between Bolt Holes	R Bolt Circle Radius	D	E1	E	F Bolts	H	K	M	N	P	S	Z	Recommended Housing Bore Diameter	Approx. Weight
4	1 7/16	ZD5107	2 9/16	1 13/16	3 9/16	3 3/4	3 5/16	3/8	5/16	1 3/4	2 5/16	7/32	5/8	2.8380	1.725	2.8360	3.40
	35.00	ZD5035MM	65.09	46.04	90.49	96.30	84.14	10.00	7.94	44.450	58.74	5.54	15.88	72.0852	43.815	72.0344	1.50
5	1 1/2	ZD5108	2 7/8	2 1/32	3 13/16	4 1/4	3 3/4	3/8	5/16	2 1/32	2 19/32	3/16	5/8	3.3500	1.930	3.3480	5.40
	1 11/16	ZD5111															4.80
	40.00	ZD5040MM	73.02	15.59	96.84	107.95	95.25	10.00	7.94	26.190	65.88	5.02	15.88	85.0900	49.022	85.0392	2.50
	45.00	ZD5045MM	73.02	15.59	96.84	107.95	95.25	10.00	7.94	26.190	65.88	5.02	15.88	85.0900	49.022	85.0392	2.30
6	1 15/16	ZD5115	3	2 1/8	3 13/16	4 1/2	4	3/8	5/16	2 5/16	2 7/8	3/16	21/32	3.5470	1.875	3.5450	5.20
	50.00	ZD5050MM	76.20	59.98	96.84	114.30	101.60	10.00	7.94	58.740	73.03	5.02	16.66	90.0938	47.625	90.0430	2.40
7	2	ZD5200	3 13/32	2 13/32	4 1/8	5 1/8	4 9/16	7/16	5/16	2 5/8	3 1/4	1/8	11/16	3.9400	1.880	3.9390	7.90
	2 3/16	ZD5203															7.30
	55.00	ZD5055MM	85.52	61.11	104.78	130.18	115.89	11.00	7.94	2 5/8	82.55	3.18	17.45	100.0760	47.752	86.1822	3.30
8	2 7/16	ZD5207	3 23/32	2 5/8	4 3/8	5 1/2	4 15/16	1/2	5/16	2 29/32	3 9/16	1/4	3/4	4.3340	2.225	4.3320	8.80
	60.00	ZD5060MM	94.43	66.68	111.13	139.70	125.41	13.00	7.94	73.810	90.49	6.35	19.05	110.0836	56.515	110.0328	4.00
	65.00	ZD5065MM															4.00
9	2 1/2	ZD5208	4 21/64	3 1/16	4 7/8	6 1/2	6	1/2	3/8	3 3/8	4 1/16	1/4	3/4	5.1200	2.600	5.1190	16.60
	2 11/16	ZD5211															15.30
	2 15/16	ZD5215	109.93	77.79	123.83	165.10	152.40	13.00	9.53	85.730	103.19	6.35	19.05	130.0480	66.040	130.0226	13.20
	70.00	ZD5070MM															7.00
	75.00	ZD5075MM															6.70
10	3 3/16	ZD5303	4 61/64	3 1/2	5 5/16	7 3/8	6 13/16	5/8	7/16	3 31/32	4 29/32	3/16	7/8	5.9080	2.664	5.9060	21.20
	3 7/16	ZD5307															19.40
	80.00	ZD5080MM	125.80	88.90	134.94	187.33	173.04	16.00	11.11	100.810	124.62	5.02	22.23	105.0632	67.666	150.0124	9.60
	85.00	ZD5085MM															9.40
	90.00	ZD5090MM															9.10
11	3 11/16	ZD5311	6 3/16	4 3/8	6 1/8	9 1/8	8 5/8	5/8	17/32	4 9/16	5 5/8	15/64	1	7.0890	3.190	7.0880	38.00
	3 15/16	ZD5315															35.00
	4	ZD5400	157.16	111.13	155.58	231.78	219.08	16.00	13.49	115.890	142.88	5.94	25.40	180.0606	81.026	180.0352	34.00
	100.00	ZD5100MM															15.90

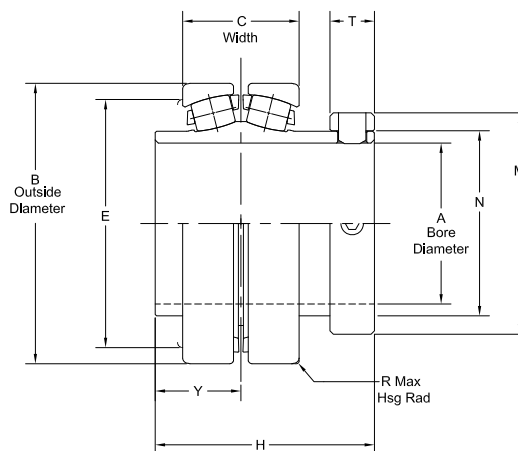
Additional Notes

- Please call 1-866-REXNORD for availability
- Metric bore sizes available, see Rex Interchangeability guide
- Bore size = nominal shaft size +.001 in/-.000 in (+0.03 mm/-0.00 mm)
- Outer race O.D. tolerance, +.000 in/-.001 in (-0.00 mm/+0.03 mm)
- Recommended housing bore diameter tolerance, +.002 in/-.000 in (+0.05 mm/-0.00 mm)
- Seals - To specify G, K or M seal, replace "Z" in part number with "G", "K" or "M"

- Auxiliary end caps - not available
- For the Selection Guide, Load Ratings and Speed Limits, see the Spherical Roller Bearings Engineering section on pages 15 - 27.
- Note: Dimensions subject to change. Certified dimensions of ordered material furnished on request.



Photo Shows an Unmounted Spherical Roller Bearing



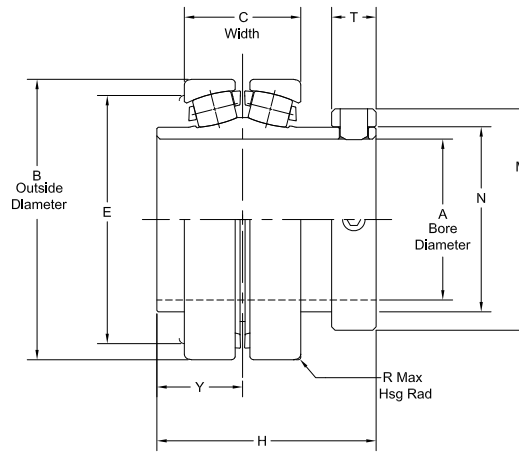
Product Features

- Precision ground & superfinished raceways
- Hardened spring locking collar
- Self aligning
- See Features and Benefits for additional info on pages 10 - 13.

Bearing Dimensions

Size Code	Shaft Diameter	Part Number	A Bore Diameter	B Outside Diameter	C Width	E	H	M	N	R Housing Max	T	Y	Approx. Weight
2	3/4	2012U	0.7500	2.3755	1.19	2.00	2.57	1.74	1.31	0.04	0.5	1.00	1.30
	15/16	2015U	0.9375										
	1	2100U	1.0000										
	25.00	2025MMU	25.00	60.3377	30.1752	50.800	65.075	44.069	33.198	1.168	12.700	25.400	0.60
3	1 1/8	2102U	1.1250	2.6255	1.31	2.31	2.69	1.96	1.53	0.05	0.5	1.06	1.80
	1 3/16	2103U	1.1875										
	1 1/4	2104U	1.2500										
	30.00	2030MMU	30.00	66.6877	33.3248	58.750	68.275	49.784	38.913	1.575	12.700	26.975	0.80
4	1 7/16	2107U	1.4375	2.8350	1.31	2.50	2.88	2.30	1.75	0.05	0.63	1.09	2.20
	1 1/2	2108U	1.5000										
	35.00	2035MMU	35.00										
5	1 11/16	2111U	1.6875	3.3469	1.58	2.88	3.13	2.58	2.03	0.05	0.63	1.22	3.20
	1 3/4	2112U	1.7500										
	40.00	2040MMU	40.00										
6	1 15/16	2115U	1.9375	3.5438	1.53	3.19	3.13	2.88	2.31	0.05	0.63	1.22	3.30
	2	2200U	2.0000										
	50.00	2050MMU	50.00										
7	2 3/16	2203U	2.1875	3.9375	1.66	3.50	3.32	3.25	2.62	0.05	0.75	1.25	4.60
	2 1/4	2204U	2.2500										
	55.00	2055MMU	55.00										
8	2 3/8	2206U	2.3750	4.3312	1.75	3.88	3.51	3.55	2.90	0.05	0.81	1.31	5.80
	2 7/16	2207U	2.4375										
	2 1/2	2208U	2.5000										
	60.00	2060MMU	60.00										
	65.00	2065MMU	65.00										
9	2 11/16	2211U	2.6875	5.1177	2.13	4.53	4.00	4.04	3.37	0.05	0.81	1.56	9.50
	2 3/4	2212U	2.7500										
	2 15/16	2215U	2.9375										
	3	2300U	3.0000										
	70.00	2070MMU	70.00										
	75.00	2075MMU	75.00										

Continued...



Continued...

Bearing Dimensions

Size Code	Shaft Diameter	Part Number	A Bore Diameter	B Outside Diameter	C Width	E	H	M	N	R Housing Max	T	Y	Approx. Weight
10	3 ³ / ₁₆	2303U	3.1875	5.9050	2.31	5.34	4.39	4.90	3.98	0.05	0.81	1.72	13.50
	3 ⁷ / ₁₆	2307U	3.4375										
	3 ¹ / ₂	2308U	3.5000										
	80.00	2080MMU	80.00	149.9870	58.7502	135.738	111.125	124.562	100.965	3.175	20.676	43.663	6.10
	90.00	2090MMU	90.00										
11	3 ¹¹ / ₁₆	2311U	3.6875	7.0861	2.75	6.38	5.20	5.63	4.56	0.05	1.00	2.00	24.00
	3 ¹⁵ / ₁₆	2315U	3.9375										
	4	2400U	4.0000										
	100.00	2100MMU	100.00	179.9869	69.8500	161.925	128.5494	142.875	115.875	3.175	25.400	50.800	10.90

Additional Notes

- Please call 1-866-REXNORD for availability
- Metric bore sizes available, see Rex Interchangeability guide
- Bearing O.D. tolerance, +.0000 in/-.0010 in (*+0.000 mm/-0.030 mm*)
- Bore tolerance for all size codes, +.0010 in/-.0000 in (*+0.030 mm/-0.000 mm*)
- For the Selection Guide, Load Ratings and Speed Limits, see the Spherical Roller Bearings Engineering section on pages 15 - 27.
- Note: Dimensions subject to change. Certified dimensions of ordered material furnished on request.

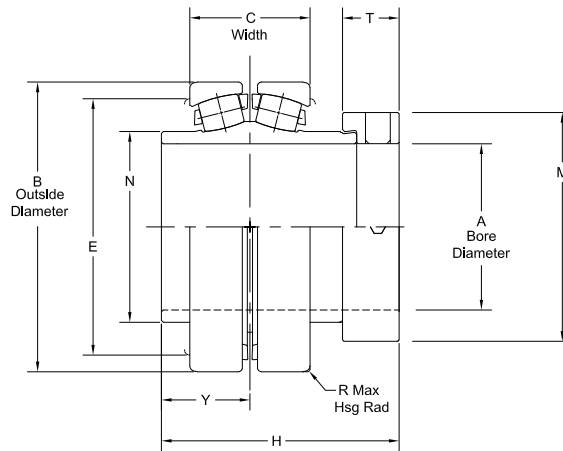
3000U



Photo Shows an Unmounted Spherical Roller Bearing

Product Features

Precision ground & superfinished raceways
 Eccentric locking collar
 Self aligning
 See Features and Benefits for additional info on pages 10 - 13.



Bearing Dimensions

Size Code	Shaft Diameter	Part Number	A Bore Diameter	B Outside Diameter	C Width	E	H	M	N	R Housing Max	T	Y	Approx. Weight
4	1 ⁷ / ₁₆	3107U	1.4375	2.8350	1.31	2.50	2.92	2.30	1.75	0.05	0.66	1.09	2.40
5	1 ¹¹ / ₁₆	3111U	1.6875	3.3469	1.58	2.88	3.18	2.58	2.03	0.05	0.68	1.22	3.40
6	1 ¹⁵ / ₁₆	3115U	1.9375	3.5438	1.53	3.19	3.28	2.75	2.31	0.05	0.72	1.22	3.50
7	2 ³ / ₁₆	3203U	2.1875	3.9375	1.66	3.50	3.50	3.25	2.62	0.05	0.92	1.25	4.90
8	2 ⁷ / ₁₆	3207U	2.4375	4.3312	1.75	3.88	3.65	3.55	2.90	0.05	0.94	1.31	6.00
	2 ¹ / ₂	3208U	2.5000										
9	2 ¹¹ / ₁₆	3211U	2.6875	5.1177	2.13	4.53	4.20	4.04	3.37	0.05	1.00	1.56	9.50
	2 ¹⁵ / ₁₆	3215U	2.9375										
10	3 ⁷ / ₁₆	3307U	3.4375	5.9050	2.31	5.34	4.57	4.90	3.98	0.05	1.00	1.72	13.00
	3 ¹ / ₂	3308U	3.5000										
11	3 ¹⁵ / ₁₆	3315U	3.9375	7.0861	2.75	6.38	5.19	5.63	4.56	0.05	1.00	2.00	23.20

Additional Notes

Please call 1-866-REXNORD for availability

Bearing O.D. tolerance, +.0000 in/-.0010 in (**+0.000 mm/-0.030 mm**)

Bore tolerance for all size codes, +.0010 in/-.0000 in (**+0.030 mm/-0.000 mm**)

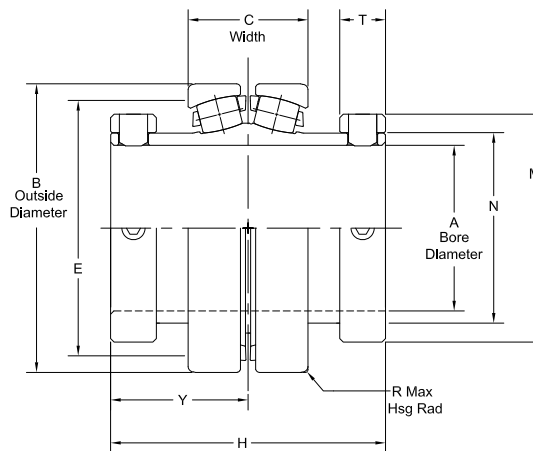
For the Selection Guide, Load Ratings and Speed Limits, see the Spherical Roller Bearings Engineering section on pages 15 - 27.

Note: Dimensions subject to change. Certified dimensions of ordered material furnished on request.

5000U



Photo Shows an Unmounted Spherical Roller Bearing



Product Features

- Precision ground & superfinished raceways
- Two hardened spring locking collars
- Self aligning
- See Features and Benefits for additional info on pages 10 - 13.

Bearing Dimensions

Size Code	Shaft Diameter	Part Number	A Bore Diameter	B Outside Diameter	C Width	E	H	M	N	R Housing Max	T	Y	Approx. Weight
4	1 ⁷ / ₁₆	5107U	1.4375	2.8350	1.31	2.50	3.45	2.30	1.75	0.05	0.63	1.78	2.70
	1 ¹ / ₂	5108U	1.5000										
5	1 ¹¹ / ₁₆	5111U	1.6875	3.3469	1.58	2.88	3.81	2.58	2.03	0.05	0.63	1.91	4.00
	1 ¹⁵ / ₁₆	5115U	1.9375										
6	2	5200U	2.0000	3.5438	1.53	3.19	3.81	2.88	2.31	0.05	0.63	1.91	4.10
	2 ³ / ₁₆	5203U	2.1875										
7	2 ⁷ / ₁₆	5207U	1.4375	4.3312	1.75	3.88	4.37	3.55	2.90	0.05	0.81	2.19	6.80
	2 ¹ / ₂	5208U	2.5000										
9	2 ¹¹ / ₁₆	5211U	2.6875	5.1177	2.13	4.53	4.87	4.04	3.37	0.05	0.81	2.44	11.50
	2 ³ / ₄	5212U	2.7500										
	2 ¹⁵ / ₁₆	5215U	2.9375										
	3 ³ / ₁₆	5303U	3.1875										
10	3 ⁷ / ₁₆	5307U	3.4375	5.9050	2.31	5.34	5.32	4.90	3.98	0.05	0.81	2.66	16.00
	3 ¹¹ / ₁₆	5311U	3.6875										
	3 ¹⁵ / ₁₆	5315U	3.9375										
11	4	5400U	4.0000	7.0861	2.75	6.38	6.25	5.63	4.56	0.05	1.00	3.06	26.00
	4 ³ / ₁₆	5403YU	4.1875										
	4 ⁷ / ₁₆	5407YU	4.4375										
	4 ¹ / ₂	5408YU	4.5000										
12	4 ¹⁵ / ₁₆	5415U	4.9375	9.0550	3.56	8.00	7.88	7.05	5.75	0.05	1.06	3.94	61.00
	5	5500U	5.0000										
13	5 ⁷ / ₁₆	5507U	5.4375	10.6322	3.91	9.25	8.00	8.19	6.50	0.05	1.19	4.00	79.00
	5 ¹⁵ / ₁₆	5515U	5.9375										
14	6	5600U	6.0000	11.4196	4.01	10.13	8.13	8.64	7.20	0.05	1.13	4.07	95.00
	6 ⁷ / ₁₆	5607U	6.4375										
15	6 ¹ / ₂	5608U	6.5000	12.6006	4.28	11.25	8.75	9.72	8.05	0.06	1.19	4.38	112.00
	6 ¹⁵ / ₁₆	5615U	6.9375										
	7	5700U	7.0000										

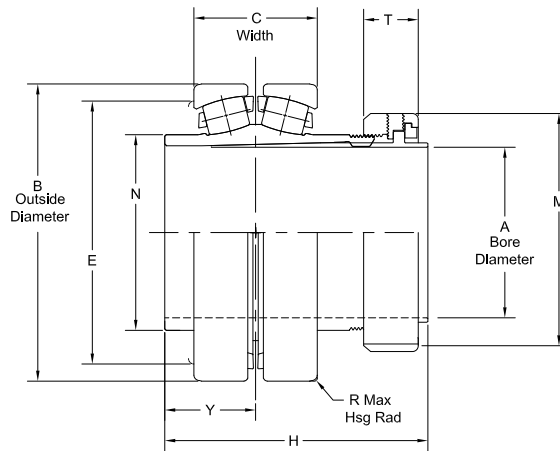
Additional Notes

- Please call 1-866-REXNORD for availability
- Metric bore sizes available, see Rex Interchangeability guide
- Bearing O.D. tolerance for size codes 4 thru 13, +.0000 in/- .0010 in (+0.000 mm/-0.030 mm); for all other size codes, +.0000 in/- .0015 in (+0.000 mm/-0.038 mm)
- Bore tolerance for all size codes, +.0010 in/- .0000 in (+0.030 mm/-0.000 mm)
- For the Selection Guide, Load Ratings and Speed Limits, see the Spherical Roller Bearings Engineering section on pages 15 - 27.

Note: Dimensions subject to change. Certified dimensions of ordered material furnished on request.



Photo Shows an Unmounted Spherical Roller Bearing



Product Features

- Spyglass Optical Strain Sensor (OSS) Technology
- Positive locking system
- Tapered adapter sleeve
- Precision ground & superfinished raceways
- Self aligning
- See Features and Benefits for additional info on pages 10 - 13.

Bearing Dimensions

Size Code	Shaft Diameter	Part Number	A Bore Diameter	B Outside Diameter	C Width	E	H	M	N	R Housing Max	T	Y	Approx. Weight
4	1 7/16	6107U	1.4375	2.8350	1.31	2.50	3.33	2.38	1.75	0.05	0.79	1.10	1.7
5	1 11/16	6111U	1.6875	3.3469	1.58	2.88	3.74	2.64	2.03	0.05	0.81	1.23	2.7
6	1 15/16	6115U	1.9375	3.5438	1.53	3.19	3.64	2.86	2.31	0.05	0.77	1.29	3.30
	45.00	6045MMU	45.00	90.0125	38.760	80.975	92.4204	72.746	58.598	1.981	19.685	32.868	1.50
7	2 3/16	6203U	2.1875	3.9375	1.66	3.50	3.77	3.24	2.62	0.05	0.82	1.25	4.60
	55.00	6055MMU	55.00	100.0125	42.0624	88.900	93.4568	81.991	66.548	1.575	20.904	31.750	2.10
8	2 3/8	6206U	2.3750	4.3312	1.75	3.88	4.16	3.59	2.90	0.05	0.90	1.31	5.80
	2 7/16	6207U	2.4375										
9	60.00	6060MMU	60.00	110.0125	44.450	98.425	103.0478	91.262	73.685	1.981	22.885	33.325	2.60
	2 3/16	6211U	2.6875	5.1177	2.13	4.53	4.53	4.09	3.37	0.05	0.94	1.56	9.50
	2 3/4	6212U	2.7500										
	2 15/16	6215U	2.9375										
	70.00	6070MMU	70.00										
75.00	6075MMU	75.00	129.9896	53.9750	115.087	115.1001	104.140	85.598	1.981	23.876	39.726	4.30	
10	3 3/16	6303U	3.1875	5.9050	2.31	5.34	5.14	4.95	3.98	0.05	1.09	1.73	13.50
	3 7/16	6307U	3.4375										
	80.00	6080MMU	80.00	149.9870	58.7502	135.738	127.7798	125.730	100.965	3.175	27.661	43.815	6.10
11	85.00	6085MMU	85.00	7.0861	2.75	6.38	5.97	5.67	4.56	0.05	1.22	2.00	24.00
	3 11/16	6311U	3.6875										
	3 15/16	6315U	3.9375										
	90.00	6090MMU	100.00	179.9869	69.8500	161.925	147.0228	144.018	115.875	3.175	31.039	50.800	10.90
12	100.00	6100MMU	100.00	7.6791	2.79	6.88	6.25	6.06	5.03	0.05	1.30	2.25	29.50
	4 3/16	6403YU	4.1875										
	4 7/16	6407YU	4.4375	195.0491	68.0491	174.752	158.8872	154.026	127.813	3.175	33.096	57.150	13.40
13	110.00	6110MMU	110.00	4.9375	3.56	8.00	7.93	6.95	5.75	0.05	1.55	2.91	61.00
	4 15/16	6415U	4.9375										
14	125.00	6125MMU	125.00	5.4375	3.97	9.25	8.77	8.02	6.50	0.05	2.01	2.92	79.00
15	5 7/16	6507U	5.4375	10.6322	3.97	9.25	8.77	8.02	6.50	0.05	2.01	2.92	79.00
16	5 15/16	6515U	5.9375	11.4196	7.01	10.13	9.30	8.66	7.20	0.05	2.21	2.93	95.00
16	6 7/16	6607U	6.4375	12.6006	4.27	11.25	10.00	9.75	8.05	0.06	2.42	3.25	112.00
	6 15/16	6615U	6.9375										

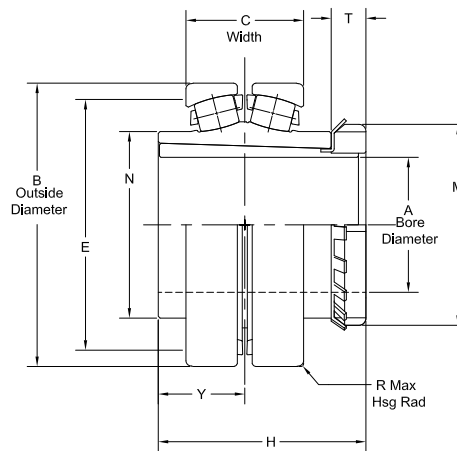
Additional Notes

- Please call 1-866-REXNORD for availability
- Bearing O.D. tolerance, +.0000 in/-.0010 in (+0.000 mm/-0.030 mm)
- Bore tolerance for all size codes, +.0010 in/-.0000 in (+0.030 mm/-0.000 mm)
- For the Selection Guide, Load Ratings and Speed Limits, see the Spherical Roller Bearings Engineering section on pages 15 - 27.
- Note: Dimensions subject to change. Certified dimensions of ordered material furnished on request.

9000U



Photo Shows an Unmounted Spherical Roller Bearing



Product Features

- Precision ground & superfinished raceways
- Enhanced life mounting style
- Self aligning
- See Features and Benefits for additional info on pages 10 - 13.

Bearing Dimensions

Size Code	Shaft Diameter	Part Number	A Bore Diameter	B Outside Diameter	C Width	E	H	M	N	R Housing Max	T	Y	Approx. Weight
7	1 ¹⁵ / ₁₆	9115U	1.9375	3.9375	1.66	3.50	3.14	2.97	2.62	0.05	0.55	1.25	4.20
	2	9200U	2.0000										
8	2 ³ / ₁₆	9203U	2.1875	4.3312	1.75	3.88	3.34	3.38	2.90	0.05	0.62	1.31	5.30
9	2 ⁷ / ₁₆	9207U	2.4375	5.1177	2.13	4.53	3.74	3.63	3.37	0.05	0.63	1.56	7.80
	2 ¹ / ₂	9208U	2.5000										
10	2 ¹¹ / ₁₆	9211U	2.6875	5.9050	2.31	5.34	4.25	4.41	3.98	0.05	0.72	1.72	13.00
	2 ¹⁵ / ₁₆	9215U	2.9375										
	3	9300U	3.0000										
11	3 ³ / ₁₆	9303U	3.1875	7.0861	2.75	6.38	5.07	5.19	4.56	0.05	0.83	2.00	25.00
	3 ⁷ / ₁₆	9307U	3.4375										
12	3 ¹¹ / ₁₆	9311YU	3.6875	7.6791	2.79	6.88	5.41	5.72	5.03	0.05	0.89	2.38	25.00
	3 ¹⁵ / ₁₆	9315YU	3.9375										
	4	9400YU	4.0000										
13	4 ³ / ₁₆	9403U	4.1875	9.0550	3.56	8.00	6.76	6.13	5.75	0.05	0.93	2.91	57.00
	4 ⁷ / ₁₆	9407U	4.4375										
14	4 ¹⁵ / ₁₆	9415U	4.9375	10.6322	3.98	9.25	7.19	7.09	6.50	0.05	1.05	2.93	69.00
	5	9500U	5.0000										
15	5 ³ / ₁₆	9503U	5.1875	11.4196	4.01	10.13	7.57	8.06	7.20	0.05	1.18	2.94	85.00
	5 ⁷ / ₁₆	9507U	5.4375										
16	5 ¹⁵ / ₁₆	9515U	5.9375	12.6006	4.28	11.25	7.75	9.06	8.05	0.06	1.24	3.25	104.00
	6	9600U	6.0000										
	6 ⁷ / ₁₆	9607U	6.4375										

Additional Notes

- Please call 1-866-REXNORD for availability
- Bearing O.D. tolerance for size codes 7 thru 13, +.0000 in/-.0010 in (+0.0000 mm/-0.030 mm); for all other size codes, +.0000 in/-.0015 in (+0.0000 mm/-0.038 mm)
- Bore tolerance for all size codes, +.0010 in/-.0000 in (+0.030 mm/-0.000 mm)
- For the Selection Guide, Load Ratings and Speed Limits, see the Spherical Roller Bearings Engineering section on pages 15 - 27.
- Note: Dimensions subject to change. Certified dimensions of ordered material furnished on request.

Rex Replacement Kits



Set Collar Kit



Eccentric Locking Collar Kit



Threaded Cover Kit



Adapter Sleeve Kit



Z Seal Kit - Contains 2 Seal Assemblies



K Seal Kit - Contains 2 Seal Assemblies



M Seal Kit - Contains 2 Seal Assemblies



G Seal Kit - Contains 2 Seal Assemblies



Microlock Assembly Kit

Part Numbers

Size Code	Z	K	M	G	Threaded Cover Kit	Set Collar Kit	Eccentric Locking Collar Kit	Microlock Assembly Kit	Adapter Assembly Kit
2	ZS2	KS2	MS2	-	TC2	SC2	-	ML2	-
3	ZS3	KS3	MS3	GS3	TC3	SC3	-	ML2	-
4	ZS4	KS4	MS4	GS4	TC4	SC4	SC3107	ML2	-
5	ZS5	KS5	MS5	GS5	TC5	SC5	SC3111	ML2	-
6	ZS6	KS6	MS6	GS6	TC6	SC6	SC3115	ML2	-
7	ZS7	KS7	MS7	GS7	TC7	SC7	SC3203	ML2	AK7115 AK7200
8	ZS8	KS8	MS8	GS8	TC8	SC8	SC3207 SC3208	ML3	AK8203
9	ZS9	KS9	MS9	GS9	TC9	SC9	SC3211 SC3215	ML3	AK9207 AK9208
10	ZS10	KS10	MS10	GS10	TC10	SC10	SC3307 SC3308	ML4*	AK10211 AK10215 AK10300
11	ZS11	KS11	MS11	GS11	TC11	SC11	SC3315	ML4	AK11303 AK11307 AK11308
12	ZS12Y	-	MS12Y	GS12	TC12Y	SC12Y	-	ML4	AK12311Y AK12315Y AK12400Y
13	ZS13	-	MS13	GS13	TC13	SC13	-	ML4	AK13403 AK13407
14	ZS14NEW	-	MS14	-	TC14NEW	SC14	-	ML4	AK14415 AK14500
15	ZS15NEW	-	MS15	-	TC15NEW	SC15	-	ML4	AK15503 AK15507
16	ZS16NEW	-	MS16	-	TC16NEW	SC16	-	ML4	AK16515 AK16600 AK16607

Additional Notes

*Floating units require ML-3



SHURLOK Installation Tools

Rex is pleased to offer a quick installation tool for the SHURLOK bearing. This tool is designed as a supplement to the spanner wrench or drift pin method. The installation tool can be attached to a 3/4" or 1/2" drive ratchet, torque wrench, or breaker bar which can be used as a lever arm. Simply fit the installation tool over the locknut by placing the tool's teeth into the locknut slots. The tool's unique shape allows it to be used from the side or the top of the bearing. To order, refer to the table below for the installation tool that fits your shaft size.

Bearing Size	Wrench Style Installation Tool Part Number	Impact Style Installation Tool Part Number
107	N6107-SPN	N6107-IMP
111	N6111-SPN	N6111-IMP
115	105-90420-11	105-90425-11
203	105-90420-21	105-90425-21
206/207	105-90420-31	105-90425-31
211/212/215	105-90420-41	105-90425-41
303/307	105-90420-51	105-90425-51
311/315	105-90420-61	105-90425-61
403/407	105-90420-71	105-90425-71
415	105-90420-81	105-90425-81
507		105-90425-91
515		105-90426-11
607/615		105-90426-21



Spherical Roller Bearings Units: Link-Belt



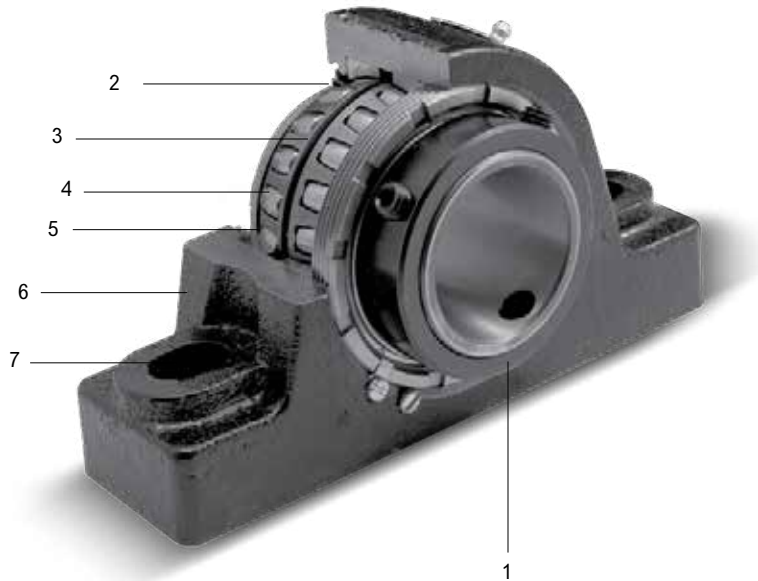
Contents

	Page
Features and Benefits	132
Nomenclature	134
Engineering	135
Dimensions	
Pillow Blocks	141
Flange Blocks	159
Cartridge Blocks	171
Take-up Blocks	177
Take-up Assemblies	181
Take-up Frames	183
Unmounted Replacement Bearings	185
Replacement Kits	189

Industries Served

Mining
Forest Products
Aggregates
Steel
Air Handling
Construction
Package Handling





Link-Belt Spherical Roller Bearings

Self-aligning double row spherical roller bearings are designed to distribute the load over the symmetrical rollers, assuring positive tracking and smooth operation. The large roller complement provides high capacity for radial or combined radial-thrust loads. Osculation clearance at the ends of the rollers compensates for shock loads and prevents destructive edge loading. These precision bearings with double contoured retainer pockets are designed to meet a broad range of application requirements.



1. Mounting feature

- B22400 Series – Spring locking collar locks inner ring securely to shaft.
- B22500 Series – Two spring locking collars lock inner ring securely to shaft.
- B22600 Series – Tapered adapter mounting system.

2. Choice of three seals

- Floating Labyrinth Type H
- Spring-Loaded Lip Type E
- Triple Lip Type E7

3. Long inner ring for high stability and load support

4. Self-aligning double row

Spherical roller bearing allows for +/- 2 degrees of misalignment to accommodate variations between shaft and support structure as well as shaft deflection during operation.

5. Double contoured retainer pockets

Assures accurate roller control.

6. One-piece cast iron or cast steel housing.

7. Slotted bolt holes in pillow block

Bases facilitate mounting; bottom of base is machined.

Spring Locking Collar(s) – B22400 & B22500 Series

The spring locking collar(s) design provides a secure grip of the wide inner ring bearing to the shaft. The setscrews extend through the inner ring of the bearing and lock firmly onto the shaft. Installation is fast and simple. Correctly tightening the setscrews produces elastic strain in the spring locking collar resulting in a continuous pressure on the setscrew threads and providing a positive lock.

Series B22400, B22500 & B22600 Spherical Roller Bearing Units and Take-ups – Features and Benefits

Series B22400 are single collar mounted spherical roller bearing units. Series B22500 are double collar mounted spherical roller bearing units. Series B22600 are adapter mounted spherical roller bearing units. These units provide economic and versatile arrangements for supporting shafts carrying substantial radial or combination radial and thrust loads. These units are especially adaptable for conveyors, elevators, general industrial machinery, heavier duty fans and blowers, power transmission applications, ditchers, trenchers, pavers and other such applications. These series of bearings are easy to mount, sealed, pre-lubricated and do not require bearing adjustment during mounting.

Adapter Mount – B22600 Series

The adapter mounting provides better concentricity and shaft control, increasing service life. Where Turned, Ground and Polished shafting is the norm on collar-mounted units, the maximized mounting power of the B22600 allows for Commercial Grade Shafting compatibility (a commonly used grade of shafting due to its price and availability). Shaft damage from set screws is eliminated with the B22600's improved mounting design. Shaft damage from the bearing inner ring fretting to the shaft (the result of a clearance or loose fit) is also eliminated. These improvements facilitate easier bearing removal, replacement bearing installation and longer shaft service life.

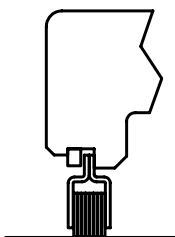


Interchangeable Seals

Three standard sealing systems are available; each offering maximum protection for various application conditions. These seals are interchangeable and are designed for grease lubrication.

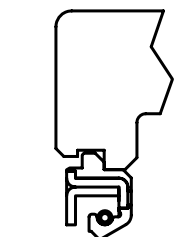
Type H Seal

Type H floating labyrinth seals have multiple self-centering rings held securely in a steel carrier. Type H seals are normally furnished.



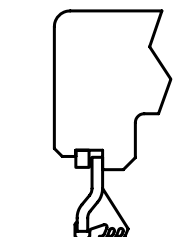
Type E Seal

Type E spring loaded lip seals utilize a spring to provide uniform pressure for keeping the sealing lip in contact with the inner ring. Type E seals are normally used for liquid splash environments.



Type E7 Seal

Type E7 triple lip seal with metal outboard guard is designed for the most severe of applications. The outboard metal guard protects the inner seal lips from abrasion and damage. The three molded, heavy contact lips provide excellent protection from abrasive media, dust and moisture.



One-Piece Cast Iron or Cast Steel Housings

Compact one-piece housings provide for strength and load support. Scientifically contoured housing design provides superior rigidity. Cast iron or cast steel pillow blocks have two or four slotted bolt holes with ample space provided for drilling dowel pin holes. Flanged and flanged cartridge units have drilled mounting

holes and machined mounting surfaces for maximum stability. Cartridge units have cast iron or steel housings and are finished to precision tolerances. Take-up units have machined slots for smooth, precise operation. Pillow blocks, flanged, and cartridge units are available for fixed or expansion operation.



Nomenclature

Symbol	Description	P	E -	B22	4	39	F	H	C	18A
C	Cartridge unit									
CSE	Cartridge unit; steel housing									
EF	Type E Flanged unit; 4-bolt square									
EP	Type E Pillow block; cast iron									
F	Flanged unit; 3- and 4-bolt									
FB	Flanged bracket unit									
FC	Flanged cartridge unit; 4-bolt round									
P	Pillow block; cast iron									
PK	Pillow block; cast steel housing									
T	Take-up unit, slotted guides									
DS	Take-up, conveyor, hinged top, welded steel frame									
DSH	Take-up, conveyor, extra strength, welded steel frame									
R	Collar opposite cover (B22400 only)									
E	Expansion unit (not used with CSE symbol)									
B22	Spherical roller bearing; extended inner ring separable outer rings									
4	400 series designation (one locking collar)									
5	500 series designation (two locking collars)									
6	600 series designation (adapter mounted)									
B	Inner ring bore equal to a bore of preceding smaller bearing group									
39	Shaft diameter in 16ths of an inch									
M55	Metric series, bore in mm									
F	Four bolt base pillow block									
H	Floating labyrinth seal									
E	Spring-loaded lip seal									
E7	Triple lip seal									
C	Closed end unit									
18	Take-up adjustment, inches									
K4	100% grease filled									
K5	No grease - preservative only									
K6	100% grease filled and housing plugged									
K93	Threaded cover held by dog point setscrews									
K98	Threaded cover held by face lock setscrews									
18A	SHC100 Grease									
18W	SHC460 Grease									
18Y	SHC220 Grease									
4C	Dow Corning DC44 Grease									
99A	Food Grade Grease									
2, 3, 4, 5	Clearances other than standard									

Seal Rating Guide

Application Conditions	Seal Ratings		
	Clearance	Heavy Contact	Triple Lip
	H	E	E7
Shaft position			
Horizontal Shaft	4	4	4
Vertical Shaft	1	4	4
Operating Temperature			
Below -40°F	4	1	1
-40°F to 0°F	4	3	3
0°F to +250°F	4	4	4
+250°F to +400°F	4	0	0
Over 400°F	4	0	0
Speed			
Equal to / Less than limit below	4	4	4
More than limit below	4	1	1
Vibration/Shock			
Occasional - Mild	3	4	4
Occasional - Severe	2	4	4
Continuous - Mild	1	3	3
Continuous - Severe	0	3	3
Abrasive Material			
Coarse - Over #10 Mesh	4	4	4
Small - #10 to #50 Mesh	3	4	4
Fine - #50 to #200 Mesh	1	4	4
Very fine - Under #200 Mesh	0	4	4
Caking or buildup (cement, etc.)	2	4	4
Moisture			
Splash	2	4	4
Rain	2	4	4
Saturated Atmosphere	1	4	4
Flooding	0	3	4
Pressure Wash	0	4	4
Fibrous Material			
Short Fibers (lint, etc.)	1	4	4
Long Fibers (grass, etc.)	1	4	4
Chemical			
Acid Fumes and Liquids	1	1	1
Alkaline Fumes and Liquids	1	1	1

Rating Code

4 - Excellent - Best seal for conditions listed.

3 - Good - Sealability is above average.

2 - Fair - Seal performs under intermittent conditions.

1 - Limited - Actual conditions must be known to evaluate sealability. Contact Rexnord for special assistance in the realm of materials and designs.

0 - Not acceptable - Will not effectively perform seal functions. Contact Rexnord for special assistance in the realm of materials and designs.

Seal Selection Guide

The choice of the seal for a mounted bearing is often the key to successful bearing operation and long service life. The SEAL SELECTION GUIDE incorporates years of Rexnord's experience against the wide variety of conditions encountered on actual applications. Following the simple selection procedure outlined can translate the benefits of that broad experience to the individual applications through the choice of the most effective seal.

How to Use the Selection Guide

1. The appropriate seal for a given application may be selected by comparing the job application conditions against those listed in the SEAL RATING GUIDE on this page.
2. When more than one application condition is present, the most appropriate seal may be selected based on prime sealing for the most detrimental condition, and secondary consideration given to the other application conditions.

Considerations in Addition to Seal Selection

Under certain adverse conditions, other changes should be considered to achieve maximum bearing life:

- A. High temperature lubricants where housing or ambient temperatures exceed +200°F,
- B. Special greases for additional bearing protection where excessive water, solvents or chemicals are present.
- C. EP (extreme pressure) greases where high load, high shock load, or continuous vibration is present.
- D. Readjustment of internal operating clearance of bearing where extreme high or low temperature conditions exist.

Seal Speed Limit Table*

Size Code	B416	B420	B424	B428	B432	B436	B440	B448	B456	B464	B572	B580	
Bearing Series	B22400	B22416	B22419 B22420	B22423 B22424	B22424 B22426 B22427 B22428	B224B28 B22431 B22432	B22435 B22436	B224B36 B22439 B22440	B22443 B22444 B22447 B22448	B22451 B22455 B22456	B22459 B22463 B22464		
	B22500			B22523	B22527	B22531	B22532 B22535	B22539	B22543 B22547	B22555	B22563 B22564	B22567 B22571 B22572	B22579 B22580
	B22600			B22623	B22627	B22631	B22635	B22639	B22643 B22647	B22655	B22663		
(RPM)	H	4500	4000	3600	3100	2800	2500	2300	1950	1650	1400	1300	1200
	E	3500	3000	2750	2350	2150	1950	1750	1500	1250	1100	1000	900
	E7	N/A	2375	2175	1850	1675	1500	1350	1150	1000	850	775	650
Size Code	B416	B420	B424	B428	B432	B436	B440	B448	B456	B464	B572	B580	

Refer to Seal Rating Guide shown above for speeds in excess of those listed in this table.

*Actual bearing speed limits are largely based upon the applied load and can be found on the Load Rating Table.

Series B22400, B22500 & B22600 Spherical Roller Bearing Selection Guide

To select a bearing, determine the applied radial load, the applied thrust load, the desired Rating Life, and applicable operating conditions. The procedure shown here will aid in selecting a bearing to meet an L₁₀ design life. The formulas for calculating life expectancy should be used to determine the Rating Life L₁₀ for the bearing selected.

The selection procedures and rating formulas shown here are in agreement with the American Bearing Manufacturers Association (ABMA) standards

and ANSI/ABMA Standards STD 11-1990. Ratings are based on fatigue life. The Rating Life L₁₀ or fatigue life at 90% reliability is the usual basis for bearing selection. For radial load applications only, Table 4, can be used to select a bearing or to determine L₁₀ life expectancy.

To assure a satisfactory bearing application, fitting practice, mounting, lubrication, sealing, static rating, housing strength, operating conditions and maintenance must be considered.

Steps for Selection

Step 1

Determine an appropriate L₁₀ design life.

Type of service	Operating time, hours per year	Design life, years	L ₁₀ design life, hours
Light seasonal usage	500 to 750	3-5	3,000
Heavy seasonal usage	1,400 to 1,600	4-6	8,000
Industrial—8 hour shift	2,000	10	20,000
Industrial—16 hour shift	4,000	10	40,000
Industrial—continuous	8,700	10	80,000 to 100,000

Step 2

Determine a required $\left(\frac{C}{P}\right)$ from Table 1.

Step 3

Calculate the required C and select a roller bearing.

a For radial load only:

$$P = F_r$$

$$\text{required } C = \left(\frac{C}{P}\right) P \text{ using } \left(\frac{C}{P}\right) \text{ from Step 2}$$

Select a roller bearing from Table 2 with a basic load rating C equal to or greater than the required C.

Step 3 (continued)

b For combined radial and thrust loads:

Select a trial roller bearing of the desired shaft size from Table 2.

Calculate the ratio of thrust load F_a to the radial load F_r .

$$\frac{F_a}{F_r}$$

Calculate the equivalent radial load P

$$P = X F_r + Y F_a$$

If $\frac{F_a}{F_r}$ is equal to or less than e, then $P = X_1 F_r + Y_1 F_a$

If $\frac{F_a}{F_r}$ is greater than e, then $P = X_2 F_r + Y_2 F_a$

For values of e, X₁, Y₁, X₂, and Y₂, see Table 2.

Calculate the required C

$$\text{required } C = \left(\frac{C}{P}\right) P \text{ using } \left(\frac{C}{P}\right) \text{ from Step 2.}$$

Consult Table 2, basic load rating. If a smaller bearing meets, or nearly meets, the required C, its life expectancy can be calculated.

Note: If the load P is greater than .25C, consult Rexnord Bearing Division.

Selection

Symbols for formulas:

- C = basic load rating, pounds (or newtons)
- Co = static load rating, pounds (or newtons)
- e = a reference value
- Fa = thrust load, pounds (or newtons)
- Fr = radial load, pounds (or newtons)
- L10 = rating life, hours
- n = speed, revolutions per minute
- P = equivalent radial load, pounds (or newtons)
- X = radial factor
- Y = thrust factor

Table 1 • Relation of L₁₀ life and speed to $\left(\frac{C}{P}\right)$

Bearing Life Hours L ₁₀	Speed, n									
	50	100	200	300	400	500	600	700	800	
3000	1.93	2.38	2.93	3.31	3.61	3.86	4.07	4.27	4.44	
4000	2.11	2.59	3.19	3.61	3.93	4.20	4.44	4.65	4.84	
5000	2.25	2.77	3.42	3.86	4.20	4.50	4.75	4.97	5.18	
6000	2.38	2.93	3.61	4.07	4.44	4.75	5.02	5.25	5.47	
8000	2.59	3.19	3.93	4.44	4.84	5.18	5.47	5.73	5.96	
10000	2.77	3.42	4.20	4.75	5.18	5.54	5.85	6.12	6.37	
12000	2.93	3.61	4.44	5.02	5.47	5.85	6.18	6.47	6.73	
14000	3.07	3.78	4.65	5.25	5.73	6.12	6.47	6.77	7.05	
16000	3.19	3.93	4.84	5.47	5.96	6.37	6.73	7.05	7.34	
18000	3.31	4.07	5.02	5.66	6.18	6.60	6.97	7.30	7.60	
20000	3.42	4.20	5.18	5.85	6.37	6.81	7.20	7.54	7.85	
25000	3.65	4.50	5.54	6.25	6.81	7.29	7.70	8.06	8.39	
30000	3.86	4.75	5.85	6.60	7.20	7.70	8.13	8.51	8.86	
35000	4.04	4.97	6.12	6.92	7.54	8.06	8.51	8.92	9.28	
40000	4.20	5.18	6.37	7.20	7.85	8.39	8.86	9.28	9.66	
45000	4.36	5.36	6.60	7.46	8.13	8.69	9.18	9.61	10.00	
50000	4.50	5.54	6.81	7.70	8.39	8.97	9.48	9.92	10.30	
60000	4.75	5.85	7.20	8.13	8.86	9.48	10.00	10.50	10.90	
70000	4.97	6.12	7.54	8.51	9.28	9.92	10.50	11.00	11.40	
80000	5.18	6.37	7.85	8.86	9.66	10.30	10.90	11.40	11.90	
90000	5.36	6.60	8.13	9.18	10.00	10.70	11.30	11.80	12.30	
100000	5.54	6.81	8.39	9.48	10.30	11.00	11.70	12.20	12.70	
150000	6.25	7.70	9.48	10.70	11.70	12.50	13.20	13.80	14.40	
200000	6.81	8.39	10.30	11.70	12.70	13.60	14.40	15.00	15.70	

	Speed, n									
	900	1000	1200	1500	1800	2400	3000	3600	6000	
3000	4.60	4.75	5.02	5.36	5.66	6.18	6.60	6.97	8.13	
4000	5.02	5.18	5.47	5.85	6.18	6.73	7.20	7.60	8.86	
5000	5.36	5.54	5.85	6.25	6.60	7.20	7.70	8.13	9.48	
6000	5.66	5.85	6.18	6.60	6.97	7.60	8.13	8.59	10.00	
8000	6.18	6.37	6.73	7.20	7.60	8.29	8.86	9.36	10.90	
10000	6.60	6.81	7.20	7.70	8.13	8.86	9.48	10.00	11.70	
12000	6.97	7.20	7.60	8.13	8.59	9.36	10.00	10.60	12.30	
14000	7.30	7.54	7.96	8.51	8.99	9.80	10.50	11.10	12.90	
16000	7.60	7.85	8.29	8.86	9.36	10.20	10.90	11.50	13.40	
18000	7.88	8.13	8.59	9.18	9.70	10.60	11.30	11.90	13.90	
20000	8.13	8.39	8.86	9.48	10.00	10.90	11.70	12.30	14.40	
25000	8.69	8.97	9.48	10.10	10.70	11.70	12.50	13.20	15.40	
30000	9.18	9.48	10.00	10.70	11.30	12.30	13.20	13.90	16.20	
35000	9.61	9.92	10.50	11.20	11.80	12.90	13.80	14.60	17.00	
40000	10.00	10.30	10.90	11.70	12.30	13.40	14.40	15.20	17.70	
45000	10.40	10.70	11.30	12.10	12.80	13.90	14.90	15.70	18.30	
50000	10.70	11.00	11.70	12.50	13.20	14.40	15.40	16.20	18.90	
60000	11.30	11.70	12.30	13.20	13.90	15.20	16.20	17.10	20.00	
70000	11.80	12.20	12.90	13.80	14.60	15.90	17.00	17.90	20.90	
80000	12.30	12.70	13.40	14.40	15.20	16.50	17.70	18.70	21.80	
90000	12.80	13.20	13.90	14.90	15.70	17.10	18.30	19.40	22.60	
100000	13.20	13.60	14.40	15.40	16.20	17.70	18.90	20.00	23.30	
150000	14.90	15.40	16.20	17.30	18.30	20.00	21.40	22.60	26.30	
200000	16.20	16.70	17.70	18.90	20.00	21.80	23.30	24.60	28.70	

Basic Formula

$$\left(\frac{C}{P}\right) = \left(\frac{L_{10} \times n \times 60}{1,000,000}\right)^{3/10}$$

$$L_{10} = \frac{\left(\frac{C}{P}\right)^{10/3} \times 1,000,000}{n \times 60}$$

Life Expectancy

To calculate the Rating Life L₁₀ of any selected or trial bearing:

Step 1

Determine the equivalent radial load P.

a For radial load only:

$$P = F_r$$

b For combined radial and thrust load:

$$P = X F_r + Y F_a$$

if $\frac{F_a}{F_r}$ is equal to or less than e, then

$$P = X_1 F_r + Y_1 F_a$$

if $\frac{F_a}{F_r}$ is greater than e, then

$$P = X_2 F_r + Y_2 F_a$$

For values of e, X₁, Y₁, X₂, and Y₂, consult the appropriate bearing rating Table 2.

Step 2

Calculate the ratio of the basic load rating C to the equivalent radial load.

$$\left(\frac{C}{P}\right)$$

Step 3

Approximate the bearing life from Table 1.

Life Adjustment

The Rating Life, L₁₀, may be modified for some applications in accordance with the formula

$$L_n = a_1 a_2 a_3 L_{10}$$

where L_n = Adjusted life for (100-n) % reliability,

a₁ = Life adjustment factor for reliability

a₂ = Life adjustment factor

for material and processing

a₃ = Life adjustment factor for operating conditions.

For most normal applications, all factors will be taken as 1, and the Rating Life used as the selection basis or life estimate. In addition, as long as standard catalog bearings are used, a₂ will be normally set equal to one.

The factor a₃ covers such things as lubrication, misalignment, and temperature. Some conditions that could yield a₃ significantly different than unity include speeds less than 20000 DN or greater than 200000 DN, temperatures below -40°F (-40°C) or above 275°F (135°C). For other possible conditions, as well as additional information on life adjustment factors, consult Rexnord Bearing Division.

Table 2 • Load Ratings and Speed Limits

Size Code	Co Static Load Rating		C Basic Load Rating		Approximate Speed Limit RPM*			e	Fa/Fr ≤ e		Fa/Fr > e	
	newtons	pounds	newtons	pounds	H seal	E seal	E7 seal		X1	Y1	X2	Y2
B416	66279	14900	62720	14100	4500	3500	---	0.51	1.00	1.32	0.67	1.96
B420	81402	18300	75175	16900	4000	3000	1700	0.48	1.00	1.40	0.67	2.08
B424 B524 B624	92968	20900	79178	17800	3600	2750	1575	0.44	1.00	1.54	0.67	2.29
B428 B528	127664	28700	109871	24700	3100	2350	1325	0.45	1.00	1.51	0.67	2.25
B432 B531 B631	147681	33200	115209	25900	2800	2150	1225	0.40	1.00	1.68	0.67	2.50
B436 B536 B635	197501	44400	144567	32500	2500	1950	1075	0.40	1.00	1.68	0.67	2.50
B440 B540 B639	237980	53500	170367	38300	2300	1750	975	0.38	1.00	1.80	0.67	2.68
B448 B548 B647	318048	71500	227304	51100	1950	1500	850	0.38	1.00	1.79	0.67	2.67
B456 B556 B655	403454	90700	277124	62300	1650	1250	725	0.38	1.00	1.77	0.67	2.64
B464 B564 B663	609406	137000	429253	96500	1400	1100	625	0.36	1.00	1.88	0.67	2.79
B572	708602	159300	486635	109400	1300	1000	550	0.38	1.00	1.80	0.67	2.68
B580	1076025	241900	739294	166200	1200	900	525	0.37	1.00	1.83	0.67	2.72

If the load P is greater than .25C, consult Rexnord Bearing Division.

For B22400 Series, reduce C Basic Load rating by 15%.

For B22500 Series, reduce C Basic Load rating by 5%.

For vertical shift application, consult Rexnord Bearing Division.

*Based on grease lubrication and moderate load.

Table 3 • Size Code Interchange Table

Shaft Size	B22400 Series Single Set Collar	B22500 Series Double Set Collar	B22600 Series Tapered Adapter	Size Code
	Bearing Number	Bearing Number	Bearing Number	
1 25 mm	B22416 <i>B224M25</i>			B416
1-3/16 1-1/4 30 mm	B22419 B22420 <i>B224M30</i>			B420
1-7/16 1-1/2 35 mm	B22423 B22424 <i>B224M35</i>	B22523	B22623	B424 B524 B624
1-1/2 1-5/8 1-11/16 1-3/4 40 mm	B224B24 B22426 B22427 B22428 <i>B224M40</i>	B22527		B428 B528
1-3/4 1-15/16 2 45 mm 50 mm	B224B28 B22431 B22432 <i>B224M45</i> <i>B224M50</i>	B22531	B22631	B432 B531 B631
2 2-3/16 2-1/4 55 mm	B22435 B22436 <i>B224M55</i>	B22532 B22535	B22635	B436 B536 B635
2-1/4 2-7/16 2-1/2 60 mm	B224B36 B22439 B22440 <i>B224M60</i>	B22539	B22639	B440 B540 B639
2-11/16 2-3/4 2-15/16 3 65 mm 70 mm 75 mm	B22443 B22444 B22447 B22448 <i>B224M65</i> <i>B224M70</i> <i>B224M75</i>	B22543 B22547	B22643 B22647	B448 B548 B647
3-3/16 3-7/16 3-1/2 80 mm 85 mm	B22451 B22455 B22456 <i>B224M80</i> <i>B224M85</i>	B22555	B22655	B456 B556 B655
3-11/16 3-15/16 4 90 mm 100 mm	B22459 B22463 B22464 <i>B224M90</i> <i>B224M100</i>	B22559 B22563 B22564	B22663	B464 B564 B663
4-3/16 4-7/16 4-1/2 110 mm 115 mm		B22567 B22571 B22572 <i>B225M110</i> <i>B225M115</i>		B572
4-15/16 5 125 mm		B22579 B22580 <i>B225M125</i>		B580

Table 4 • Radial Load Ratings in Pounds at Various RPM for Appropriate L₁₀ Life Hours

Size Code	L ₁₀ Lifehours	50	100	200	300	400	500	600	700	800	900	1000	1200	1500	1800	2000	2500	3000	3500
B416	8000	*	*	*	3175	2912	2724	2579	2462	2365	2283	2212	2095	1959	1855	1797	1681	1591	1519
	20000	*	3353	2724	2412	2212	2069	1959	1870	1797	1735	1681	1591	1488	1409	1365	1277	1209	1154
	40000	3353	2724	2212	1959	1797	1681	1591	1519	1460	1409	1365	1292	1209	1144	1109	1037	982	937
	100000	2547	2069	1681	1488	1365	1277	1209	1154	1109	1070	1037	982	918	869	842	788	746	712
B420	8000	*	*	*	3805	3491	3265	3091	2951	2835	2737	2652	2510	2348	2223	2154	2014	1907	1821
	20000	*	4019	3265	2891	2652	2480	2348	2242	2154	2079	2014	1907	1784	1689	1636	1530	1449	1383
	40000	4019	3265	2652	2348	2154	2014	1907	1821	1749	1689	1636	1549	1449	1372	1329	1243	1177	1124
	100000	3053	2480	2014	1784	1636	1530	1449	1383	1329	1283	1243	1177	1101	1042	1010	944	894	854
B424	8000	*	*	*	4008	3676	3438	3255	3108	2986	2883	2793	2644	2473	2341	2268	2122	2009	1918
	B524	*	4233	3438	3045	2793	2612	2473	2361	2268	2190	2122	2009	1879	1779	1723	1612	1526	1457
	B624	4233	3438	2793	2473	2268	2122	2009	1918	1843	1779	1723	1632	1526	1445	1400	1309	1239	1183
	100000	3216	2612	2122	1879	1723	1612	1526	1457	1400	1351	1309	1239	1159	1097	1063	994	942	899
B428	8000	*	*	*	5561	5102	4771	4517	4313	4144	4000	3875	3669	3432	3249	3148	2944	2787	2661
	B528	*	5874	4771	4225	3875	3625	3432	3277	3148	3039	2944	2787	2607	2468	2391	2236	2117	2022
	40000	5874	4771	3875	3432	3148	2944	2787	2661	2557	2468	2391	2264	2117	2005	1942	1817	1720	1642
	100000	4462	3625	2944	2607	2391	2236	2117	2022	1942	1875	1817	1720	1609	1523	1476	1380	1307	1247
B432	8000	*	*	*	5832	5349	5003	4737	4523	4345	4194	4064	3847	3598	3407	3301	3087	2923	2791
	B531	*	6159	5003	4430	4064	3801	3598	3436	3301	3186	3087	2923	2733	2588	2507	2345	2220	2120
	B631	6159	5003	4064	3598	3301	3087	2923	2791	2681	2588	2507	2374	2220	2102	2037	1905	1803	1722
	100000	4679	3801	3087	2733	2507	2345	2220	2120	2037	1966	1905	1803	1687	1597	1547	1447	1370	1308
B436	8000	*	*	*	7318	6713	6278	5944	5675	5452	5263	5099	4828	4515	4275	4142	3874	3668	3502
	B536	*	7729	6278	5559	5099	4769	4515	4311	4142	3998	3874	3668	3430	3247	3146	2943	2786	2660
	B635	7729	6278	5099	4515	4142	3874	3668	3502	3364	3247	3146	2979	2786	2638	2556	2390	2263	2161
	100000	5871	4769	3874	3430	3146	2943	2786	2660	2556	2467	2390	2263	2116	2004	1941	1816	1719	1641
B440	8000	*	*	*	8624	7911	7398	7005	6688	6425	6202	6009	5689	5321	5038	4881	4565	4322	4120
	B540	*	9108	7398	6551	6009	5620	5321	5081	4881	4712	4565	4322	4042	3827	3708	3468	3283	3120
	B639	9108	7398	6009	5321	4881	4565	4322	4127	3965	3827	3708	3511	3283	3109	3012	2817	2667	2520
	100000	6919	5620	4565	4042	3708	3468	3283	3135	3012	2907	2817	2667	2494	2361	2288	2140	2026	1920
B448	8000	*	*	*	11506	10554	9871	9346	8923	8573	8275	8018	7591	7099	6722	6512	6091	5827	5582
	B548	*	12153	9871	8740	8018	7499	7099	6779	6512	6286	6091	5766	5393	5106	4947	4627	4427	4242
	B647	12153	9871	8018	7099	6512	6091	5766	5506	5290	5106	4947	4684	4381	4147	4018	3758	3558	3373
	100000	9232	7499	6091	5393	4947	4627	4381	4183	4018	3879	3758	3558	3328	3151	3053	2855	2687	2537
B456	8000	*	*	*	14027	12868	12034	11394	10879	10452	10089	9775	9255	8655	8195	7940	7426	7026	6641
	B556	*	14816	12034	10656	9775	9142	8655	8264	7940	7664	7426	7030	6575	6225	6031	5641	5281	4941
	B655	14816	12034	9775	8655	7940	7426	7030	6713	6449	6225	6031	5710	5341	5056	4899	4582	4291	4021
	100000	11255	9142	7426	6575	6031	5641	5341	5099	4899	4729	4582	4338	4057	3841	3722	3481	3261	3061
B464	8000	*	*	*	21728	19931	18641	17649	16851	16189	15627	15141	14335	13407	12693	12298	11693	11193	10703
	B564	*	22949	18641	16506	15141	14161	13407	12801	12298	11871	11502	10890	10185	9643	9343	8843	8353	7873
	B663	22949	18641	15141	13407	12298	11502	10890	10398	9989	9643	9343	8845	8272	7832	7588	7158	6738	6328
	100000	17434	14161	11502	10185	9343	8738	8272	7899	7588	7325	7097	6719	6284	5950	5765	5345	5025	4715
B572	8000	*	*	*	42870	39326	36779	34822	33248	31942	30833	29874	28284	26453	25045	23739	22433	21127	19821
	20000	*	45281	36779	32567	29874	27940	26453	25257	24265	23423	22694	21486	20095	19025	18025	17025	16025	15025
	40000	45281	36779	29874	26453	24265	22694	21486	20515	19710	19025	18433	17452	16322	15453	14583	13713	12843	11973
	100000	34398	27940	22694	20095	18433	17240	16322	15584	14973	14453	14003	13258	12399	11739	11079	10419	9759	9100
B580	8000	*	*	*	37422	34327	32105	30396	29022	27882	26914	26077	24689	23090	21691	20492	19293	18094	16895
	20000	*	39525	32105	28428	26077	24389	23090	22047	21181	20446	19810	18755	17541	16541	15541	14541	13541	12541
	40000	39525	32105	26077	23090	21181	19810	18755	17908	17204	16607	16090	15234	14248	13448	12648	11848	11048	10248
	100000	30026	24389	19810	17541	16090	15049	14248	13604	13069	12616	12223	11573	10823	10173	9523	8873	8223	7573

* Load exceeds 25% of the C rating, consult Rexnord Bearing Division.

PB22400, PEB22400

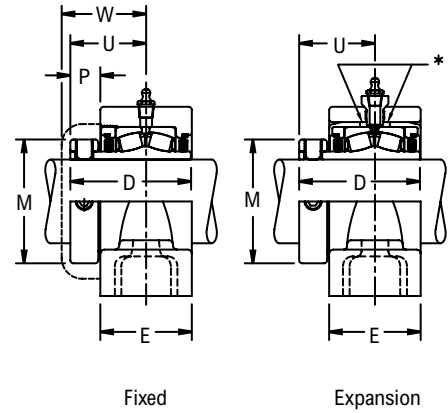
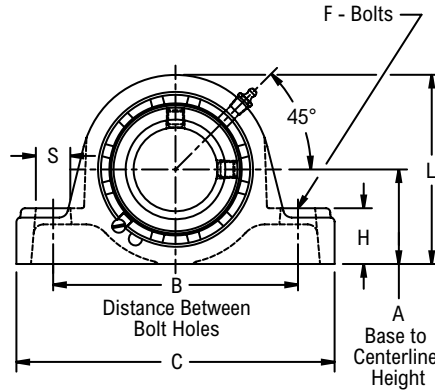
Interchange: P2BS2, SYR, USRB5000, QAPL



Photo Shows a 2-Bolt Spherical Roller Bearing Pillow Block Unit

Product Features

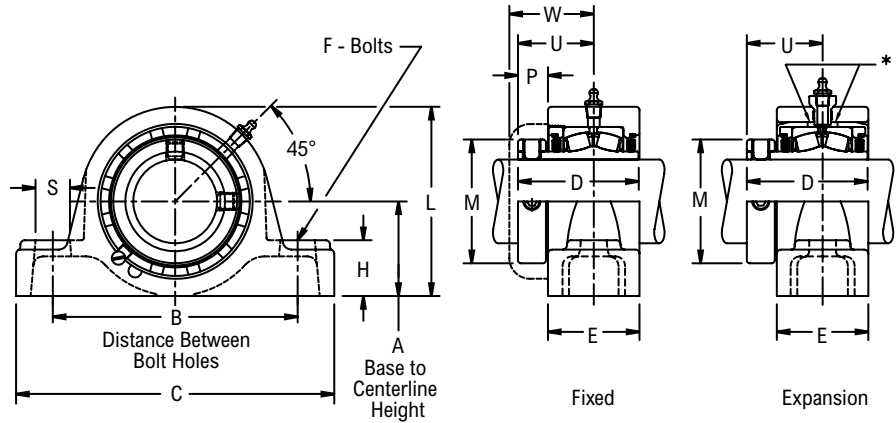
- Corrosion-resistant powder coating
- Cast iron housing
- Misalignment capabilities - total of 4°
- Broad range of sealing options
- Factory set clearance & lubrication
- Hardened spring locking collar
- Field interchangeable seals
- Fixed or Expansion - total of 3/8" expansion
- See Features and Benefits for additional info on pages 132 - 133.



Bearing Dimensions

Size Code	Shaft Diameter	Expansion			Fixed			A Base to Centerline Height	B Distance Between Bolt Holes	C	D	E	F Bolts	H	M	P	U	W	Approx. Weight
		Part Number	L	S	Part Number	L	S												
B416	1	PEB22416H	3 5/16	5/8	PB22416H	3 1/8	5/8	1 9/16	4 3/8	5 15/16	2 9/16	2 1/16	3/8	7/8	1 3/4	17/32	1 9/16	1 29/32	5.00
	25.00	PEB224M25H	84.10	15.90	PB224M25H	79.40	15.90	39.67	111.10	150.80	65.09	52.40	10.00	22.20	44.40	13.50	39.70	48.40	2.10
B420	1 3/16	PEB22419H	3 5/8	5/8	PB22419H	3 1/2	5/8	1 3/4	4 3/4	6 5/16	2 11/16	2 3/16	3/8	1 1/16	1 31/32	17/32	1 5/8	1 31/32	6.00
	1 1/4	PEB22420H			PB22420H														
	30.00	PEB224M30H	92.10	15.90	PB224M30H	88.90	15.90	44.45	120.60	160.30	68.26	55.60	10.00	27.00	50.00	13.50	41.30	50.00	2.90
B424	1 7/16	PEB22423H	3 7/8	7/8	PB22423H	3 11/16	13/16	1 7/8	5	6 9/16	2 7/8	2 1/4	1/2	1 3/16	2 5/16	2 1/32	1 25/32	2 3/16	7.00
	1 1/2	PEB22424H			PB22424H														
	35.00	PEB224M35H	98.40	22.22	PB224M35H	93.70	20.60	47.62	127.00	166.69	73.02	57.20	12.00	30.20	58.70	16.70	45.20	55.60	3.20
B428	1 5/8	PEB22426H	4 3/8	7/8	PB22426H	4 1/4	13/16	2 1/8	5 1/2	7 1/8	3 1/8	2 1/2	1/2	1 5/16	2 19/32	2 1/32	1 29/32	2 1/4	10.00
	1 11/16	PEB22427H			PB22427H														
	1 3/4	PEB22428H			PB22428H														
	40.00	PEB224M40H	111.10	22.22	PB224M40H	108.00	20.60	53.98	139.70	180.98	79.38	63.50	12.00	33.30	65.90	16.70	48.40	57.20	4.70
B432	1 15/16	PEB22431H	4 9/16	15/16	PB22431H	4 9/16	15/16	2 1/4	6 1/4	8 1/8	3 1/8	2 1/2	5/8	1 3/8	2 7/8	2 1/32	1 29/32	2 9/32	12.00
	2	PEB22432H			PB22432H														
	45.00	PEB224M45H	115.90	23.80	PB224M45H	115.90	23.80	57.15	158.80	206.38	79.38	63.50	16.00	34.90	73.00	16.70	48.40	57.90	5.50
	50.00	PEB224M50H			PB224M50H														5.20
B436	2 3/16	PEB22435H	5	15/16	PB22435H	5	15/16	2 1/2	6 3/4	8 5/8	3 5/16	2 9/16	5/8	1 5/8	3 1/4	25/32	2 1/16	2 7/16	14.00
	2 1/4	PEB22436H			PB22436H														
	55.00	PEB224M55H	127.00	23.80	PB224M55H	127.00	23.80	63.50	171.40	219.08	84.14	65.10	16.00	41.30	82.60	19.80	52.40	61.90	6.50
B440	2 7/16	PEB22439H	5 1/2	15/16	PB22439H	5 1/2	15/16	2 3/4	7 1/8	9 1/8	3 1/2	2 11/16	5/8	1 5/8	3 9/16	27/32	2 3/16	2 9/16	17.00
	2 1/2	PEB22440H			PB22440H														
	60.00	PEB224M60H	139.70	23.80	PB224M60H	139.70	23.80	69.85	181.00	231.78	88.90	68.30	16.00	41.30	90.50	21.40	55.60	65.10	8.00
B448	2 11/16	PEB22443H	6 7/16	1 1/16	PB22443H	6 7/16	1 1/16	3 1/4	8 1/8	10 7/16	4	3 3/16	3/4	2	4 1/16	27/32	2 7/16	2 25/32	29.00
	2 3/4	PEB22444H			PB22444H														
	2 15/16	PEB22447H			PB22447H														27.00
	3	PEB22448H			PB22448H														
	65.00	PEB224M65H			PB224M65H														13.20
	70.00	PEB224M70H	163.50	27.00	PB224M70H	163.50	27.00	82.55	206.40	265.10	101.60	81.00	20.00	57.20	103.20	21.40	61.90	70.60	13.00
	75.00	PEB224M75H			PB224M75H														12.50
B456	3 3/16	PEB22451H	7 1/2	1 5/8	PB22451H	7 1/2	1 5/8	3 3/4	10	13	4 3/8	3 7/16	7/8	2 1/4	4 29/32	15/16	2 21/32	3	43.00
	3 7/16	PEB22455H			PB22455H														
	3 1/2	PEB22456H			PB22456H														41.00
	80.00	PEB224M80H	190.50	41.30	PB224M80H	190.50	41.30	95.25	254.00	330.20	111.12	87.30	24.00	57.20	124.60	23.80	67.50	76.20	19.60
	85.00	PEB224M85H			PB224M85H														19.10

Continued...



Continued...

Bearing Dimensions

Size Code	Shaft Diameter	Expansion			Fixed			A Base to Centerline Height	B Distance Between Bolt Holes	C	D	E	F Bolts	H	M	P	U	W	Approx. Weight
		Part Number	L	S	Part Number	L	S												
B464	3 11/16	PEB22459H	8 1/2	2 1/4	PB22459H	8 1/2	2 1/4	4 1/4	11 3/4	15 1/4	5 1/16	4 3/16	1	2 5/8	5 5/8	1 1/16	3 1/16	3 7/16	61.00
	3 15/16	PEB22463H			PB22463H														59.00
	4	PEB22464H	PB22464H																
	90.00	PEB224M90H	215.90	57.20	PB224M90H	215.90	57.20												107.95
100.00	PEB224M100H			PB224M100H															26.90
B464L	3 15/16	-	-	-	PLB22463H	8 3/8	1 7/8	4 1/8	10 7/8	14 1/4	5 1/16	4 3/16	1	2 1/2	5 5/8	1 1/16	3 1/16	3 7/16	58.00
	4	-	-	-	PLB22464H														

Additional Notes

Please call 1-866-REXNORD for availability
 Lubrication fitting tap size, 1/8" PT
 Base to centerline tolerance, +/- .005" (+/- 0.13 mm)
 Expansion - is 3/8" for all size codes
 H labyrinth seals standard

All size codes available with type E lip seals, except E7 in size code B416
 For the Selection Guide, Load Ratings and Speed Limits, see the Link-Belt Spherical Roller Bearings Engineering section on pages 135 - 140.

Note: Dimensions subject to change. Certified dimensions of ordered material furnished on request.

PB22400F, PEB22400F

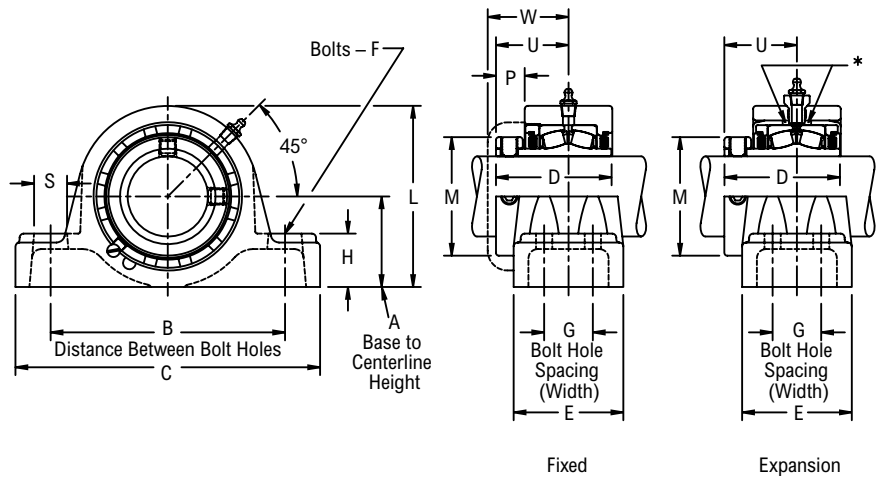
Interchange: P4BS2, FSYR, USRBF5000, QAPF



Photo Shows a 4-Bolt Spherical Roller Bearing Pillow Block Unit

Product Features

- Corrosion-resistant powder coating
- Cast iron housing
- Misalignment capabilities - total of 4°
- Broad range of sealing options
- Factory set clearance & lubrication
- Hardened spring locking collar
- Field interchangeable seals
- Fixed or Expansion - total of 3/8" expansion
- See Features and Benefits for additional info on pages 132 - 133.



Bearing Dimensions

Size Code	Shaft Diameter	Expansion		Fixed		A Base to Centerline Height	B Distance Between Bolt Holes	G Bolt Hole Spacing (Width)	C	D	E	F Bolts	H	L	M	P	S	U	W	Approx. Weight														
		Part Number	Part Number																															
B432	1 15/16	PEB22431FH	PB22431FH	2 1/4	6 1/4	1 19/32	8 3/8	3 1/8	3 3/16	1/2	1 3/8	4 9/16	2 7/8	21/32	13/16	1 29/32	2 9/32	2 9/32	13.00															
	2	PEB22432FH	PB22432FH																															
	45.00	PEB224M45FH	PB224M45FH																	57.15	158.80	40.50	212.70	79.38	81.00	12.00	34.90	115.90	73.00	16.70	20.60	48.40	57.90	6.30
	50.00	PEB224M50FH	PB224M50FH																															
B436	2 3/16	PEB22435FH	PB22435FH	2 1/2	6 3/4	1 11/16	8 7/8	3 5/16	3 1/4	1/2	1 5/8	5	3 1/4	25/32	13/16	2 1/16	2 7/16	15.00																
	2 1/4	PEB22436FH	PB22436FH																															
	55.00	PEB224M55FH	PB224M55FH																63.50	171.40	42.90	225.40	84.14	82.60	12.00	41.30	127.00	82.60	19.80	20.60	52.40	61.90	6.90	
B440	2 7/16	PEB22439FH	PB22439FH	2 3/4	7 1/8	1 3/4	9 1/4	3 1/2	3 3/8	1/2	1 3/4	5 1/2	3 9/16	27/32	13/16	2 3/16	2 9/16	19.00																
	2 1/2	PEB22440FH	PB22440FH																															
	60.00	PEB224M60FH	PB224M60FH																69.85	181.00	44.40	235.00	88.90	85.70	12.00	44.40	139.70	90.50	21.40	20.60	55.60	65.10	8.60	
B448	2 11/16	PEB22443FH	PB22443FH	3 1/4	8 1/8	1 7/8	10 7/16	4	3 3/4	5/8	2 1/4	6 7/16	4 1/16	27/32	15/16	2 7/16	2 25/32	30.00																
	2 3/4	PEB22444FH	PB22444FH																															
	2 15/16	PEB22447FH	PB22447FH																															
	3	PEB22448FH	PB22448FH																															
	65.00	PEB224M65FH	PB224M65FH																														29.00	
	70.00	PEB224M70FH	PB224M70FH																82.55	206.40	47.60	265.10	101.60	95.20	16.00	57.20	163.50	103.20	21.40	23.80	61.90	70.60	13.50	
75.00	PEB224M75FH	PB224M75FH																13.00																
B456	3 3/16	PEB22451FH	PB22451FH	3 3/4	10	2	13	4 3/8	4 1/8	3/4	2 1/4	7 1/2	4 29/32	15/16	1 1/2	2 21/32	3	45.00																
	3 7/16	PEB22455FH	PB22455FH																															
	3 1/2	PEB22456FH	PB22456FH																															
	80.00	PEB224M80FH	PB224M80FH																95.25	254.00	50.80	330.20	111.12	104.80	20.00	57.20	190.50	124.60	23.80	38.10	67.50	76.20	20.50	
85.00	PEB224M85FH	PB224M85FH																20.00																
B464	3 11/16	PEB22459FH	PB22459FH	4 1/4	12 1/2	2 1/4	15 1/4	5 1/16	4 1/2	3/4	2 5/8	8 1/2	5 5/8	1 1/16	1 1/4	3 1/16	3 7/16	69.00																
	3 15/16	PEB22463FH	PB22463FH																															
	4	PEB22464FH	PB22464FH																															
	90.00	PEB224M90FH	PB224M90FH																107.95	317.50	57.20	387.40	128.59	114.30	20.00	66.70	215.90	142.90	27.00	31.80	77.80	87.30	32.10	
100.00	PEB224M100FH	PB224M100FH																30.30																

Additional Notes

- Please call 1-866-REXNORD for availability
- Lubrication fitting tap size, 1/8" PT
- Base to centerline tolerance, +/- .005" (+/- 0.13 mm)
- Expansion - is 3/8" for all size codes
- H labyrinth seals standard
- All size codes available with type E lip seals & E7 triple lip seals

For the Selection Guide, Load Ratings and Speed Limits, see the Link-Belt Spherical Roller Bearings Engineering section on pages 135 - 140.

Note: Dimensions subject to change. Certified dimensions of ordered material furnished on request.

PB22500, PEB22500, PB22500F, PEB22500F

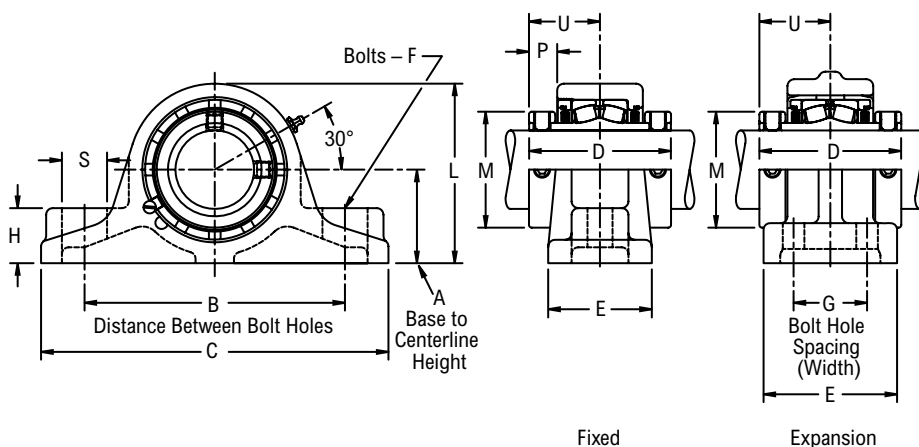
Interchange: QAAPL, QAAPF



Photo Shows a 4-Bolt Spherical Roller Bearing Pillow Block Unit

Product Features

- Corrosion-resistant powder coating
- Cast iron housing
- Misalignment capabilities - total of 4°
- Broad range of sealing options
- Factory set clearance & lubrication
- Two hardened spring locking collars
- Field interchangeable seals
- Fixed or Expansion - total of 3/8" expansion
- See Features and Benefits for additional info on pages 132 - 133.



Bearing Dimensions

Size Code	Shaft Diameter	Expansion		Fixed		A Base to Centerline Height	B Distance Between Bolt Holes	G Bolt Hole Spacing (Width)	C	D	E	F Bolts	H	M	P	S	U	Approx. Weight
		Part Number	L	Part Number	L													
Two-Bolt Pillow Block																		
B524	1 7/16	PEB22523H	4 11/32	PB22523H	3 11/32	2 1/8	5 7/8	-	8 1/8	3 9/16	2 7/16	1/2	1 1/8	2 5/16	11/16	1 1/8	1 25/32	10.00
B528	1 11/16	PEB22527H	4 13/16	PB22527H	4 7/16	2 3/16	6 1/2	-	9	3 13/16	2 13/16	1/2	1 5/16	2 19/32	23/32	1 1/4	1 29/32	12.00
B531	1 15/16	PEB22531H	4 15/16	PB22531H	4 3/4	2 1/2	7	-	9 3/4	3 13/16	2 7/8	5/8	1 7/16	2 7/8	23/32	1 1/4	1 29/32	14.00
B536	2	PEB22532H	5 23/32	PB22532H	5 1/4	2 3/4	7 1/2	-	10 1/4	4 1/8	3 1/8	5/8	1 5/8	3 1/4	25/32	1 1/4	2 1/16	21.00
	2 3/16	PEB22535H		PB22535H														20.00
B540	2 7/16	PEB22539H	6 3/16	PB22539H	5 3/4	3	8 1/4	-	11 1/4	4 3/8	3 3/8	3/4	1 3/4	3 9/16	13/16	1 3/8	2 3/16	24.00
B548	2 11/16	PEB22543H	7 3/16	PB22543H	6 23/32	3 1/2	9 3/4	-	13	4 7/8	3 7/8	7/8	2 1/16	4 1/16	29/32	1 5/8	2 7/16	39.00
	2 15/16	PEB22547H		PB22547H														37.00
Four-Bolt Pillow Block																		
B531	1 15/16	PEB22531FH	4 7/8	PB22531FH	4 7/8	2 1/2	7	2 1/4	9	3 13/16	3 13/16	1/2	1 11/16	2 7/8	23/32	7/8	1 29/32	16.00
B536	2	PEB22532FH	5 15/32	PB22532FH	5 15/32	2 3/4	7 1/2	2 1/4	9 15/16	4 1/8	4	1/2	2	3 1/4	25/32	1 1/8	2 1/16	22.00
	2 3/16	PEB22535FH		PB22535FH														
B540	2 7/16	PEB22539FH	5 7/8	PB22539FH	5 7/8	3	8 5/8	2 5/8	10 5/8	4 3/8	4 3/8	1/2	2 1/8	3 9/16	13/16	1 1/8	2 3/16	26.00
B548	2 11/16	PEB22543FH	6 15/16	PB22543FH	6 15/16	3 1/2	9 3/4	2 3/4	12 5/8	4 7/8	4 3/4	5/8	2 5/16	4 1/16	29/32	1 1/2	2 7/16	38.00
	2 15/16	PEB22547FH		PB22547FH														36.00
B556	3 7/16	PEB22555FH	8	PB22555FH	8	4	11 1/2	3	14 1/4	5 5/16	5	3/4	2 1/2	4 29/32	15/16	1 1/2	2 21/32	56.00
B564	3 15/16	PEB22563FH	8 13/16	PB22563FH	8 13/16	4 7/16	12 1/4	3 3/8	15 5/8	6 1/8	5 5/8	7/8	2 7/8	5 5/8	1 1/16	1 13/16	3 1/16	76.00
	4	PEB22564FH		PB22564FH														
B572	4 3/16	PEB22567YFH	9 3/8	PB22567YFH	9 3/8	4 3/4	13 1/2	2 1/2	16 1/2	6 1/4	4 5/8	3/4	2 3/4	6 3/16	1	1 3/8	3 1/8	92.00
	4 7/16	PEB22571YFH		PB22571YFH														88.00
	4 1/2	PEB22572YFH		PB22572YFH														87.00
	110.00	PEB225M110YFH		PB225M110YFH														40.70
115.00	PEB225M115YFH	PB225M115YFH	39.50															
B580	4 15/16	PEB22579YFH	11 1/8	PB22579YFH	11 1/8	5 1/2	15 1/2	2 3/4	18 1/2	7 7/8	5 9/16	7/8	3	7 1/16	1 5/32	1 1/2	3 15/16	129.00
	5	PEB22580YFH		PB22580YFH														128.00
	125.00	PEB225M125YFH	282.57	PB225M125YFH	282.57	139.70	393.70	69.80	469.90	200.02	141.34	24.00	76.20	179.38	29.37	38.10	100.01	58.10

Additional Notes

- Please call 1-866-REXNORD for availability
- Lubrication fitting tap size, 1/8" PT
- Base to centerline tolerance, +/- .005" (+/- 0.13 mm)
- Expansion - is 3/8" for all size codes
- H labyrinth seals standard

- All size codes available with type E lip seals & E7 triple lip seals
- For the Selection Guide, Load Ratings and Speed Limits, see the Link-Belt Spherical Roller Bearings Engineering section on pages 135 - 140.
- Note: Dimensions subject to change. Certified dimensions of ordered material furnished on request.

PB22600, PEB22600

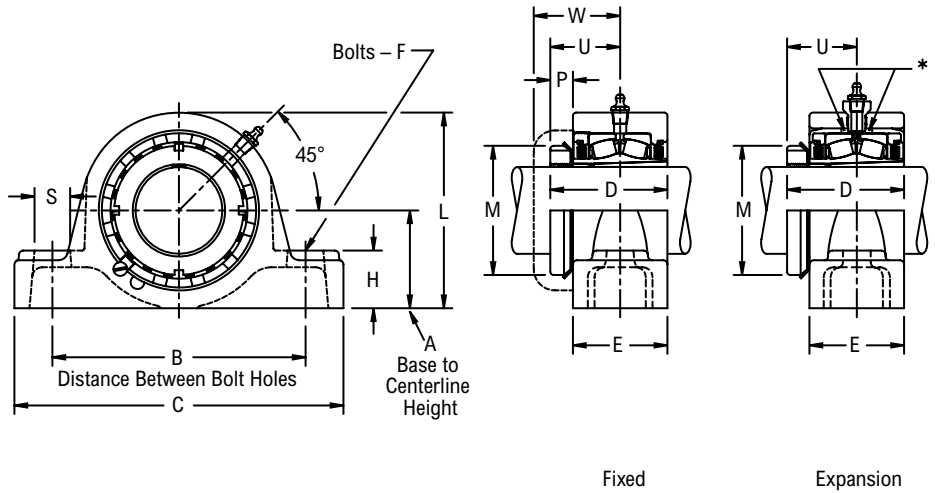
Interchange: P2BIP, SYR-N, USRB5000A, QVVPL



Photo Shows a 2-Bolt Spherical Roller Bearing Pillow Block Unit

Product Features

- Corrosion-resistant powder coating
- Cast iron housing
- Misalignment capabilities - total of 4°
- Broad range of sealing options
- Factory set clearance & lubrication
- Enhanced life mounting style
- Field interchangeable seals
- Fixed or Expansion - total of 3/8" expansion
- See Features and Benefits for additional info on pages 132 - 133.



Bearing Dimensions

Size Code	Shaft Diameter	Expansion			Fixed			A Base to Centerline Height	B Distance Between Bolt Holes	C	D	E	F Bolts	H	M	P	U	W	Approx. Weight
		Part Number	L	S	Part Number	L	S												
B624	1 7/16	PEB22623H	3 7/8	7/8	PB22623H	3 11/16	13/16	1 7/8	5	6 9/16	2.71	2 1/4	1/2	1 3/16	2 1/4	1/2	1 39/64	2 3/16	7.00
B631	1 15/16	PEB22631H	4 9/16	15/16	PB22631H	4 9/16	15/16	2 1/4	6 1/4	8 1/8	3.08	2 1/2	5/8	1 3/8	2 31/32	39/64	1 55/64	2 9/32	12.00
B635	2 3/16	PEB22635H	5	15/16	PB22635H	5	15/16	2 1/2	6 3/4	8 5/8	3.16	2 9/16	5/8	1 5/8	3 5/32	5/8	1 29/32	2 7/16	14.00
B639	2 7/16	PEB22639H	5 1/2	15/16	PB22639H	5 1/2	15/16	2 3/4	7 1/8	9 1/8	3.28	2 11/16	5/8	1 5/8	3 5/8	45/64	1 31/32	2 9/16	17.00
B647	2 11/16	PEB22643H	6 7/16	1 1/16	PB22643H	6 7/16	1 1/16	3 1/4	8 1/8	10 7/16	3.86	3 3/16	3/4	2	4 5/32	3/4	2 19/64	2 25/32	29.00
	2 15/16	PEB22647H			PB22647H														27.00
B655	3 7/16	PEB22655H	7 1/2	1 5/8	PB22655H	7 1/2	1 5/8	3 3/4	10	13	4.29	3 7/16	7/8	2 1/4	4 15/16	7/8	2 37/64	3	42.00
B663	3 15/16	PEB22663H	8 1/2	2 1/4	PB22663H	8 1/2	2 1/4	4 1/4	11 3/4	15 1/4	4.94	4 3/16	1	2 5/8	5 7/16	15/16	2 15/16	3 7/16	59.00

Additional Notes

- Please call 1-866-REXNORD for availability
- Lubrication fitting tap size, 1/8" PT
- Base to centerline tolerance, +/- .005" (+/- 0.13 mm)
- Expansion - is 3/8" for all size codes
- Dimensions for "D", "P" & "U" based on unmounted condition
- H labyrinth seals standard

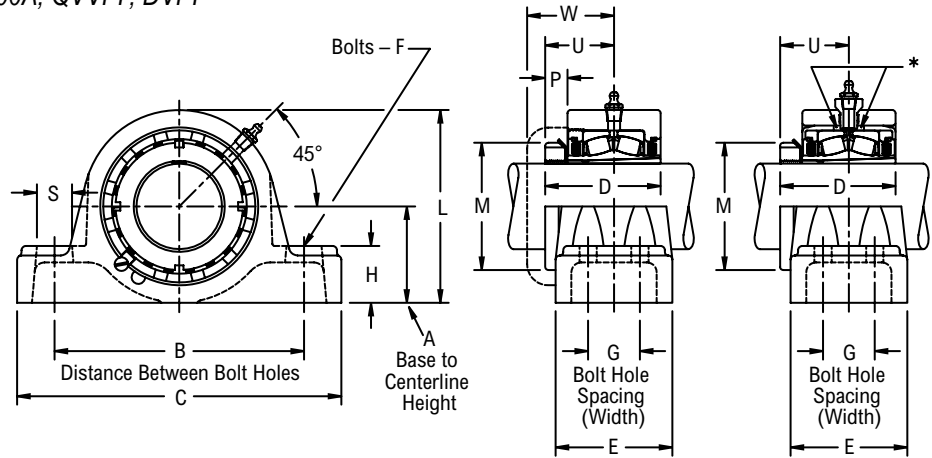
- All size codes available with type E lip seals & E7 triple lip seals
- For the Selection Guide, Load Ratings and Speed Limits, see the Link-Belt Spherical Roller Bearings Engineering section on pages 135 - 140.
- Note: Dimensions subject to change. Certified dimensions of ordered material furnished on request.

PB22600F, PEB22600F

Interchange: P4BIP, FSYR-N, USRBF5000A, QVVPF, DVPF



Photo Shows a 4-Bolt Spherical Roller Bearing Pillow Block Unit



Fixed

Expansion

Product Features

- Corrosion-resistant powder coating
- Cast iron housing
- Misalignment capabilities - total of 4°
- Broad range of sealing options
- Factory set clearance & lubrication
- Enhanced life mounting style
- Field interchangeable seals
- Fixed or Expansion - total of 3/8" expansion
- See Features and Benefits for additional info on pages 132 - 133.

Bearing Dimensions

Size Code	Shaft Diameter	Expansion		Fixed		A Base to Centerline Height	B Distance Between Bolt Holes	G Bolt Hole Spacing (Width)	C	D	E	F Bolts	H	M	P	S	U	W	Approx. Weight
		Part Number	L	Part Number	L														
B631	1 15/16	PEB22631FH	4 9/16	PB22631FH	4 9/16	2 1/4	6 1/4	1 19/32	8 3/8	3.08	3 3/16	1/2	1 3/8	2 31/32	39/64	13/16	1 55/64	2 9/32	13.00
B635	2 3/16	PEB22635FH	5	PB22635FH	5	2 1/2	6 3/4	1 11/16	8 7/8	3.16	3 1/4	1/2	1 5/8	3 5/32	5/8	13/16	1 29/32	2 7/16	15.00
B639	2 7/16	PEB22639FH	5 1/2	PB22639FH	5 1/2	2 3/4	7 1/8	1 3/4	9 1/4	3.28	3 3/8	1/2	1 3/4	3 5/8	9/8	13/16	1 31/32	2 9/16	19.00
B647	2 11/16	PEB22643FH	6 7/16	PB22643FH	6 7/16	3 1/4	8 1/8	1 7/8	10 7/16	3.86	3 3/4	5/8	2 1/4	4 5/32	46/64	15/16	2 19/64	2 25/32	30.00
	2 15/16	PEB22647FH		PB22647FH															29.00
B655	3 7/16	PEB22655FH	7 1/2	PB22655FH	7 1/2	3 3/4	10	2	13	4.29	4 1/8	3/4	2 1/4	4 15/16	55/64	1 1/2	2 37/64	3	43.00
B663	3 15/16	PEB22663FH	8 1/2	PB22663FH	8 1/2	4 1/4	12 1/2	2 1/4	15 1/4	4.94	4 1/2	3/4	2 5/8	5 7/16	15/16	1 1/4	2 15/16	3 7/16	67.00

Additional Notes

- Please call 1-866-REXNORD for availability
- Lubrication fitting tap size, 1/8" PT
- Base to centerline tolerance, +/- .005" (+/-0.13 mm)
- Expansion - is 3/8" for all size codes
- Dimensions for "D", "P" & "U" based on unmounted condition
- H labyrinth seals standard

All size codes available with type E lip seals & E7 triple lip seals
 For the Selection Guide, Load Ratings and Speed Limits, see the Link-Belt Spherical Roller Bearings Engineering section on pages 135 - 140.

Note: Dimensions subject to change. Certified dimensions of ordered material furnished on request.

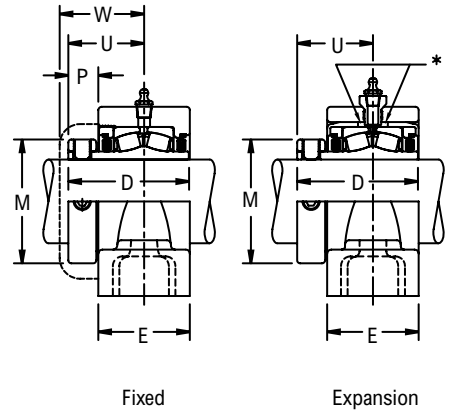
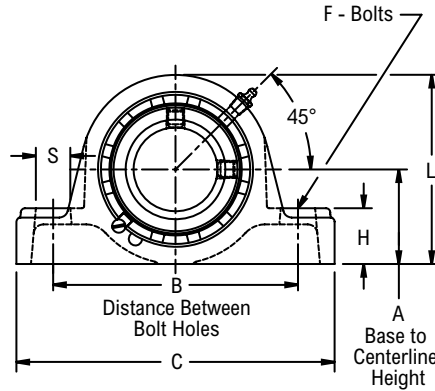
PKB22400, PKEB22400



Photo Shows a 2-Bolt Spherical Roller Bearing Pillow Block Unit

Product Features

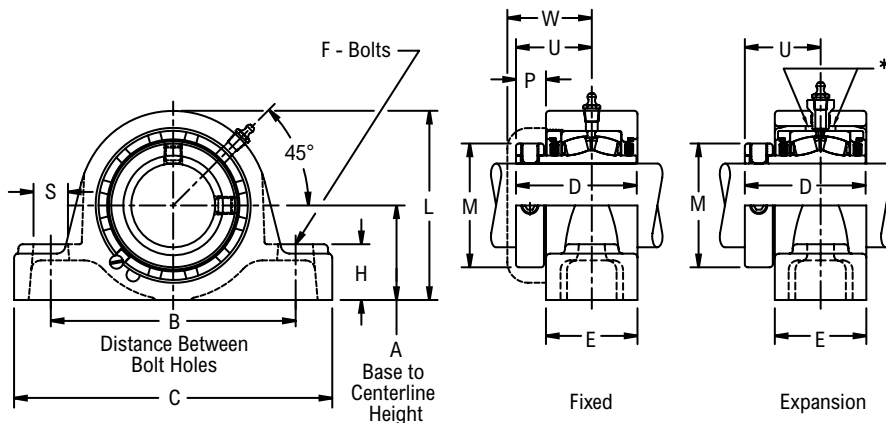
- Corrosion-resistant powder coating
- Cast steel housing
- Misalignment capabilities - total of 4°
- Broad range of sealing options
- Factory set clearance & lubrication
- Hardened spring locking collar
- Field interchangeable seals
- Fixed or Expansion - total of 3/8" expansion
- See Features and Benefits for additional info on pages 132 - 133.



Bearing Dimensions

Size Code	Shaft Diameter	Expansion		Fixed		A Base to Centerline Height	B Distance Between Bolt Holes	C	D	E	F Bolts	H	M	P	S	U	W	Approx. Weight												
		Part Number	L	Part Number	L																									
B420	1 3/16	-	-	PKB22419H	3 1/2	1 3/4	4 3/4	6 5/16	2 11/16	2 3/16	3/8	1 1/16	1 31/32	17/32	5/8	1 5/8	1 31/32	7.00												
	1 1/4	-	-	PKB22420H														3.20												
	30.00	-	-	PKB224M30H														88.90	44.45	120.60	160.30	68.26	55.60	10.00	27.00	50.00	13.50	15.90	41.30	50.00
B424	1 7/16	PKEB22423H	3 7/8	PKB22423H	3 11/16	1 7/8	5	6 7/8	2 7/8	2 1/4	1/2	1 3/16	2 5/16	21/32	13/16	1 25/32	2 3/16	7.00												
	1 1/2	PKEB22424H		PKB22424H														3.40												
	35.00	PKEB224M35H		PKB224M35H														93.70	47.62	127.00	174.60	73.02	57.20	12.00	30.20	58.70	16.70	20.60	45.20	55.60
B428	1 5/8	PKEB22426H	4 3/8	PKB22426H	4 1/4	2 1/8	5 1/2	7 1/8	3 1/8	2 1/2	1/2	1 5/16	2 19/32	21/32	13/16	1 29/32	2 1/4	10.00												
	1 11/16	PKEB22427H		PKB22427H														4.80												
	1 3/4	PKEB22428H		PKB22428H														108.00	53.98	139.70	187.30	79.38	63.50	12.00	33.30	65.90	16.70	20.60	48.40	57.20
	40.00	PKEB224M40H		PKB224M40H														111.10	55.90	145.90	199.30	81.38	66.50	12.00	33.30	65.90	16.70	20.60	48.40	57.20
B432	1 15/16	PKEB22431H	4 9/16	PKB22431H	4 9/16	2 1/4	6 1/4	8 3/8	3 1/8	2 1/2	5/8	1 3/8	2 7/8	21/32	15/16	1 29/32	2 9/32	12.00												
	2	PKEB22432H		PKB22432H														5.80												
	45.00	PKEB224M45H		PKB224M45H														115.90	57.15	158.80	212.70	79.38	63.50	16.00	34.90	73.00	16.70	23.80	48.40	57.90
B436	2 3/16	PKEB22435H	5	PKB22435H	5	2 1/2	6 3/4	8 7/8	3 5/16	2 9/16	5/8	1 5/8	3 1/4	25/32	15/16	2 1/16	2 7/16	16.00												
	2 1/4	PKEB22436H		PKB22436H														7.10												
	55.00	PKEB224M55H		PKB224M55H														127.00	63.50	171.40	225.40	84.14	65.10	16.00	41.30	82.60	19.80	23.80	52.40	61.90
B440	2 7/16	PKEB22439H	5 1/2	PKB22439H	5 1/2	2 3/4	7 1/8	9 1/4	3 1/2	2 11/16	5/8	1 3/4	3 9/16	27/32	15/16	2 3/16	2 9/16	19.00												
	2 1/2	PKEB22440H		PKB22440H														18.00												
	60.00	PKEB224M60H		PKB224M60H														139.70	69.85	181.00	235.00	88.90	68.30	16.00	44.40	90.50	21.40	23.80	55.60	65.10
B448	2 11/16	PKEB22443H	6 7/16	PKB22443H	6 7/16	3 1/4	8 1/8	10 7/16	4	3 3/16	3/4	2 1/4	4 1/16	27/32	1 1/16	2 7/16	2 25/32	30.00												
	2 3/4	PKEB22444H		PKB22444H														29.00												
	2 15/16	PKEB22447H		PKB22447H														28.00												
	3	PKEB22448H		PKB22448H														13.70												
	65.00	PKEB224M65H		PKB224M65H														163.50	82.55	206.40	265.10	101.60	81.00	20.00	57.20	103.20	21.40	27.00	61.90	70.60
	70.00	PKEB224M70H		PKB224M70H														163.50	82.55	206.40	265.10	101.60	81.00	20.00	57.20	103.20	21.40	27.00	61.90	70.60
75.00	PKEB224M75H	PKB224M75H	163.50	82.55	206.40	265.10	101.60	81.00	20.00	57.20	103.20	21.40	27.00	61.90	70.60															
B456	3 3/16	PKEB22451H	7 1/2	PKB22451H	7 1/2	3 3/4	10	13	4 3/8	3 7/16	7/8	2 1/4	4 29/32	15/16	1 5/8	2 21/32	3	45.00												
	3 7/16	PKEB22455H		PKB22455H														43.00												
	3 1/2	PKEB22456H		PKB22456H														20.20												
	80.00	PKEB224M80H		PKB224M80H														190.50	95.25	254.00	330.20	111.12	87.30	24.00	57.20	124.60	23.80	41.30	67.50	76.20
85.00	PKEB224M85H	PKB224M85H	190.50	95.25	254.00	330.20	111.12	87.30	24.00	57.20	124.60	23.80	41.30	67.50	76.20															
B464	3 11/16	PKEB22459H	8 1/2	PKB22459H	8 1/2	4 1/4	11 3/4	15 1/4	5 1/16	4 9/16	1	2 5/8	5 5/8	1 1/16	2 1/4	3 1/16	3 7/16	64.00												
	3 15/16	PKEB22463H		PKB22463H														62.00												

Continued...



Continued...

Bearing Dimensions

Size Code	Shaft Diameter	Expansion		Fixed		A Base to Centerline Height	B Distance Between Bolt Holes	C	D	E	F Bolts	H	M	P	S	U	W	Approx. Weight
		Part Number	L	Part Number	L													
B464	4	PKEB22464H	8 1/2	PKB22464H	8 1/2	4 1/4	11 3/4	15 1/4	5 1/16	4 3/16	1	2 5/8	5 5/8	1 1/16	2 1/4	3 1/16	3 7/16	62.00
	90.00	PKEB224M90H	215.90	PKB224M90H	215.90	107.95	298.40	387.40	128.59	106.4	24.00	66.70	142.90	27.00	57.20	77.80	87.30	29.90
	100.00	PKEB224M100H		PKB224M100H														28.10

Additional Notes

Please call 1-866-REXNORD for availability
 Lubrication fitting tap size, 1/8" PT
 Base to centerline tolerance, +/- .005" (+/- 0.13 mm)
 Expansion - is 3/8" for all size codes
 H labyrinth seals standard

All size codes available with type E lip seals & E7 triple lip seals
 For the Selection Guide, Load Ratings and Speed Limits, see the Link-Belt Spherical Roller Bearings Engineering section on pages 135 - 140.
 Note: Dimensions subject to change. Certified dimensions of ordered material furnished on request.

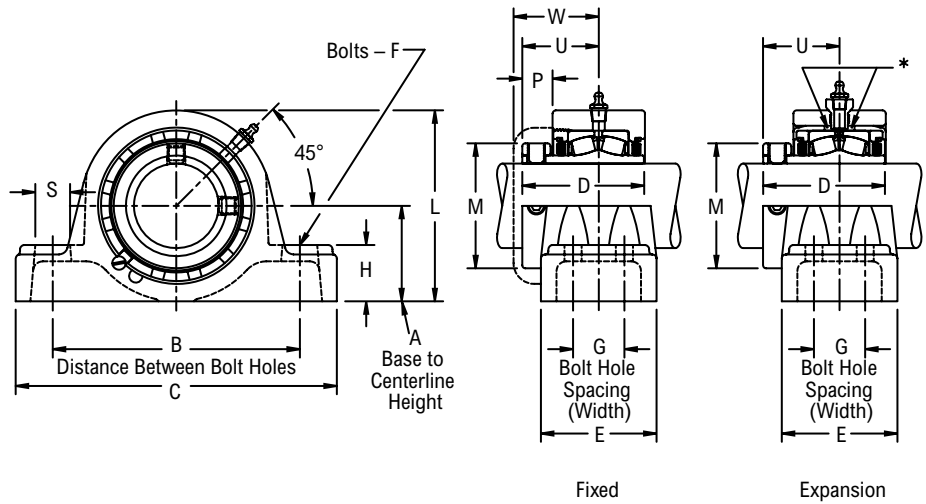
PKB22400F, PKEB22400F



Photo Shows a 4-Bolt Spherical Roller Bearing Pillow Block Unit

Product Features

- Corrosion-resistant powder coating
- Cast steel housing
- Misalignment capabilities - total of 4°
- Broad range of sealing options
- Factory set clearance & lubrication
- Hardened spring locking collar
- Field interchangeable seals
- Fixed or Expansion - total of 3/8" expansion
- See Features and Benefits for additional info on pages 132 - 133.



Bearing Dimensions

Size Code	Shaft Diameter	Expansion		Fixed		A Base to Centerline Height	B Distance Between Bolt Holes	G Bolt Hole Spacing (Width)	C	D	E	F Bolts	H	L	M	P	S	U	W	Approx. Weight
		Part Number	Part Number	Part Number	Part Number															
B432	1 15/16	PKEB22431FH	PKB22431FH	2 1/4	6 1/4	1 19/32	8 3/8	3 1/8	3 3/16	1/2	1 3/8	4 9/16	2 7/8	21/32	13/16	1 29/32	2 9/32	13.00	6.10	5.80
	2	PKEB22432FH	PKB22432FH																	
	45.00	PKEB224M45FH	PKB224M45FH																	
	50.00	PKEB224M50FH	PKB224M50FH																	
B436	2 3/16	PKEB22435FH	PKB22435FH	2 1/2	6 3/4	1 11/16	8 7/8	3 5/16	3 1/4	1/2	1 5/8	5	3 1/4	25/32	13/16	2 1/16	2 7/16	16.00	61.90	7.30
	2 1/4	PKEB22436FH	PKB22436FH																	
	55.00	PKEB224M55FH	PKB224M55FH																	
B440	2 7/16	PKEB22439FH	PKB22439FH	2 3/4	7 1/8	1 3/4	9 1/4	3 1/2	3 3/8	1/2	1 3/4	5 1/2	3 9/16	27/32	13/16	2 3/16	2 9/16	20.00	65.10	9.30
	2 1/2	PKEB22440FH	PKB22440FH																	
	60.00	PKEB224M60FH	PKB224M60FH																	
B448	2 11/16	PKEB22443FH	PKB22443FH	3 1/4	8 1/8	1 7/8	10 7/16	4	3 3/4	5/8	2 1/4	6 7/16	4 1/16	27/32	15/16	2 7/16	2 25/32	28.00	29.00	13.70
	2 3/4	PKEB22444FH	PKB22444FH																	
	2 15/16	PKEB22447FH	PKB22447FH																	
	3	PKEB22448FH	PKB22448FH																	
	65.00	PKEB224M65FH	PKB224M65FH																	
	70.00	PKEB224M70FH	PKB224M70FH																	
B456	3 3/16	PKEB22451FH	PKB22451FH	3 3/4	10	2	13	4 3/8	4 1/8	3/4	2 1/4	7 1/2	4 29/32	15/16	1 1/2	2 21/32	3	49.00	47.00	22.00
	3 7/16	PKEB22455FH	PKB22455FH																	
	3 1/2	PKEB22456FH	PKB22456FH																	
	80.00	PKEB224M80FH	PKB224M80FH																	
	85.00	PKEB224M85FH	PKB224M85FH																	
B464	3 11/16	PKEB22459FH	PKB22459FH	4 1/4	12 1/2	2 1/4	15 1/4	5 1/16	4 1/2	3/4	2 5/8	8 1/2	5 5/8	1 1/16	1 1/4	3 1/16	3 7/16	76.00	74.00	35.20
	3 15/16	PKEB22463FH	PKB22463FH																	
	4	PKEB22464FH	PKB22464FH																	
	90.00	PKEB224M90FH	PKB224M90FH																	
	100.00	PKEB224M100FH	PKB224M100FH																	

Additional Notes

- Please call 1-866-REXNORD for availability
- Lubrication fitting tap size, 1/8" PT
- Base to centerline tolerance, +/- .005" (+/- 0.13 mm)
- Expansion - is 3/8" for all size codes
- H labyrinth seals standard
- All size codes available with type E lip seals & E7 triple lip seals

For the Selection Guide, Load Ratings and Speed Limits, see the Link-Belt Spherical Roller Bearings Engineering section on pages 135 - 140.

Note: Dimensions subject to change. Certified dimensions of ordered material furnished on request.

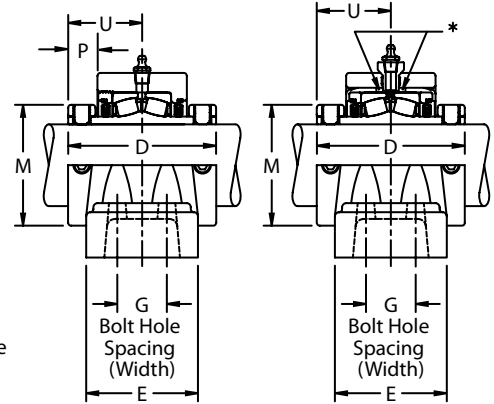
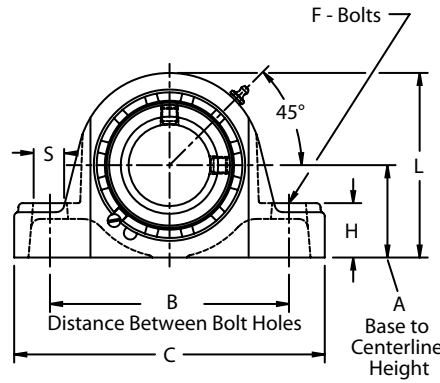
PKB22500F, PKEB22500F



Photo Shows a 4-Bolt Spherical Roller Bearing Pillow Block Unit

Product Features

- Corrosion-resistant powder coating
- Cast steel housing
- Misalignment capabilities - total of 4°
- Broad range of sealing options
- Factory set clearance & lubrication
- Two hardened spring locking collars
- Field interchangeable seals
- Fixed or Expansion - total of 3/8" expansion
- See Features and Benefits for additional info on pages 132 - 133.



Fixed

Expansion

Bearing Dimensions

Size Code	Shaft Diameter	Expansion		Fixed		A Base to Centerline Height	B Distance Between Bolt Holes	G Bolt Hole Spacing (Width)	C	D	E	F Bolts	H	L	M	P	S	U	Approx. Weight
		Part Number	Part Number																
B572	4 ³ / ₁₆	PKEB22567YFH	PKB22567YFH	4 ³ / ₄	13 ¹ / ₂	2 ¹ / ₂	16 ¹ / ₂	6 ¹ / ₄	4 ³ / ₄	¾	2 ³ / ₄	10	6 ³ / ₁₆	1	1 ²⁹ / ₆₄	3 ¹ / ₈			97.00
	4 ⁷ / ₁₆	PKEB22571YFH	PKB22571YFH																93.00
	4 ¹ / ₂	PKEB22572YFH	PKB22572YFH																92.00
	110.00	PKEB225M110YFH	PKB225M110YFH	120.65	342.90	63.50	419.10	158.75	120.60	20.00	69.80	254.00	157.16	25.4	36.90	79.50	43.00		
	115.00	PKEB225M115YFH	PKB225M115YFH																41.70
B580	4 ¹⁵ / ₁₆	PKEB22579YFH	PKB22579YFH	5 ¹ / ₂	15 ¹ / ₂	2 ³ / ₄	18 ¹ / ₂	7 ⁷ / ₈	6 ³ / ₈	7/8	3	11 ²³ / ₃₂	7 ¹ / ₁₆	1 ⁵ / ₃₂	1 ⁹ / ₁₆	3 ¹⁵ / ₁₆			125.00
	5	PKEB22580YFH	PKB22580YFH																124.00
	125.00	PKEB225M125YFH	PKB225M125YFH																139.70

Additional Notes

- Please call 1-866-REXNORD for availability
- Lubrication fitting tap size, 1/8" PT
- Base to centerline tolerance, +/- .005" (+/- 0.13 mm)
- Expansion - is 3/8" for all size codes
- H labyrinth seals standard

All size codes available with type E lip seals & E7 triple lip seals
 For the Selection Guide, Load Ratings and Speed Limits, see the Link-Belt Spherical Roller Bearings Engineering section on pages 135 - 140.

Note: Dimensions subject to change. Certified dimensions of ordered material furnished on request.

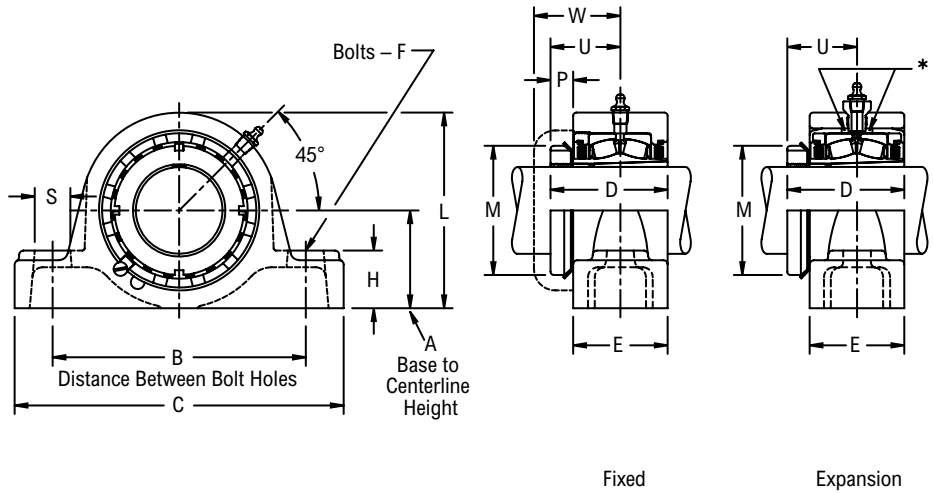
PKB22600, PKEB22600



Photo Shows a 2-Bolt Spherical Roller Bearing Pillow Block Unit

Product Features

- Corrosion-resistant powder coating
- Cast steel housing
- Misalignment capabilities - total of 4°
- Broad range of sealing options
- Factory set clearance & lubrication
- Enhanced life mounting style
- Field interchangeable seals
- Fixed or Expansion - total of 3/8" expansion
- See Features and Benefits for additional info on pages 132 - 133.



Bearing Dimensions

Size Code	Shaft Diameter	Expansion		Fixed		A Base to Centerline Height	B Distance Between Bolt Holes	C	D	E	F Bolts	H	M	P	U	S	W	Approx. Weight
		Part Number	L	Part Number	L													
B624	1 7/16	PKEB22623H	3 7/8	PKB22623H	3 11/16	1 7/8	5	6 7/8	2.71	2 1/4	1/2	1 3/16	2 1/4	1/2	1 39/64	13/16	2 3/16	7.00
B631	1 15/16	PKEB22631H	4 9/16	PKB22631H	4 9/16	2 1/4	6 1/4	8 3/8	3.08	2 1/2	5/8	1 3/8	2 31/32	39/64	1 55/64	15/16	2 9/32	12.00
B635	2 3/16	PKEB22635H	5	PKB22635H	5	2 1/2	6 3/4	8 7/8	3.16	2 9/16	5/8	1 5/8	3 5/32	5/8	1 29/32	15/16	2 7/16	16.00
B639	2 7/16	PKEB22639H	5 1/2	PKB22639H	5 1/2	2 3/4	7 1/8	9 1/4	3.28	2 11/16	5/8	1 3/4	3 5/8	45/64	1 31/32	15/16	2 9/16	18.00
B647	2 11/16	PKEB22643H	6 7/16	PKB22643H	6 7/16	3 1/4	8 1/8	10 7/16	3.86	3 3/16	3/4	2 1/4	4 5/32	55/64	2 19/64	1 1/16	2 25/32	30.00
	2 15/16	PKEB22647H		PKB22647H														29.00
B655	3 7/16	PKEB22655H	7 1/2	PKB22655H	7 1/2	3 3/4	10	13	4.29	3 7/16	7/8	2 1/4	4 15/16	7/8	2 37/64	1 5/8	3	43.00
B663	3 15/16	PKEB22663H	8 1/2	PKB22663H	8 1/2	4 1/4	11 3/4	15 1/4	4.94	4 3/16	1	2 5/8	5 7/16	1 5/16	2 15/16	2 1/4	3 7/16	62.00

Additional Notes

- Please call 1-866-REXNORD for availability
- Lubrication fitting tap size, 1/8" PT
- Base to centerline tolerance, +/- .005" (+/- 0.13 mm)
- Expansion - is 3/8" for all size codes
- Dimensions for "D", "P" & "U" based on unmounted condition
- H labyrinth seals standard

- All size codes available with type E lip seals & E7 triple lip seals
- For the Selection Guide, Load Ratings and Speed Limits, see the Link-Belt Spherical Roller Bearings Engineering section on pages 135 - 140.
- Note: Dimensions subject to change. Certified dimensions of ordered material furnished on request.

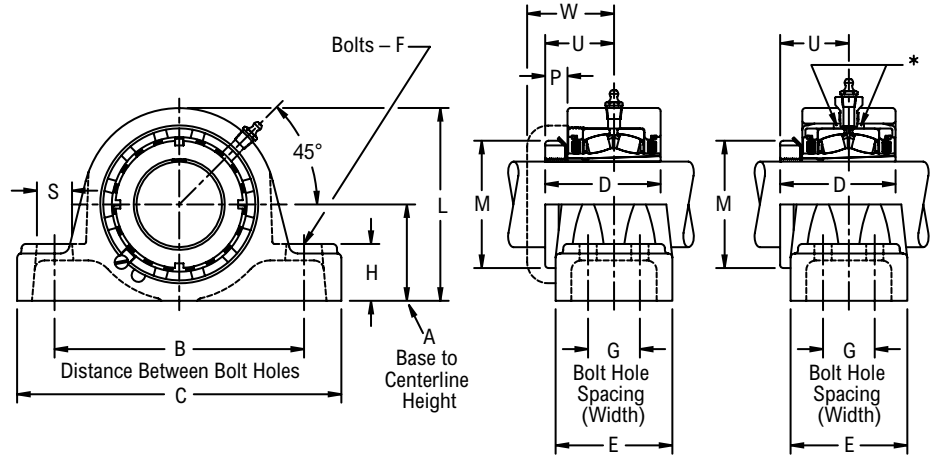
PKB22600F, PKEB22600F



Photo Shows a 4-Bolt Spherical Roller Bearing Pillow Block Unit

Product Features

- Corrosion-resistant powder coating
- Cast steel housing
- Misalignment capabilities - total of 4°
- Broad range of sealing options
- Factory set clearance & lubrication
- Enhanced life mounting style
- Field interchangeable seals
- Fixed or Expansion - total of 3/8" expansion
- See Features and Benefits for additional info on pages 132 - 133.



Fixed

Expansion

Bearing Dimensions

Size Code	Shaft Diameter	Expansion		Fixed		A Base to Centerline Height	B Distance Between Bolt Holes	G Bolt Hole Spacing (Width)	C	D	E	F Bolts	H	L	M	P	S	U	W	Approx. Weight
		Part Number	Part Number																	
B631	1 15/16	PKEB22631FH	PKB22631FH	2 1/4	6 1/4	1 19/32	8 3/8	3.08	3 3/16	1/2	1 3/8	4 9/16	2 31/32	39/64	13/16	1 55/64	2 9/32			13.00
B635	2 3/16	PKEB22635FH	PKB22635FH	2 1/2	6 3/4	1 11/16	8 7/8	3.16	3 1/4	1/2	1 5/8	5	3 5/32	5/8	13/16	1 29/32	2 7/16			16.00
B639	2 7/16	PKEB22639FH	PKB22639FH	2 3/4	7 1/8	1 3/4	9 1/4	3.28	3 3/8	1/2	1 3/4	5 1/2	3 5/8	5/8	13/16	1 31/32	2 9/16			20.00
B647	2 11/16	PKEB22643FH	PKB22643FH	3 1/4	8 1/8	1 7/8	10 7/16	3.86	3 3/4	5/8	2 1/4	6 7/16	4 5/32	46/64	15/16	2 19/64	2 25/32			30.00
	2 15/16	PKEB22647FH	PKB22647FH																	29.00
B655	3 7/16	PKEB22655FH	PKB22655FH	3 3/4	10	2	13	4.29	4 1/8	3/4	2 1/4	7 1/2	4 15/16	55/64	1 1/2	2 37/64	3			47.00
B663	3 15/16	PKEB22663FH	PKB22663FH	4 1/4	12 1/2	2 1/4	15 1/4	4.94	4 1/2	3/4	2 5/8	8 1/2	5 7/16	15/16	1 1/4	2 15/16	3 7/16			74.00

Additional Notes

- Please call 1-866-REXNORD for availability
- Lubrication fitting tap size, 1/8" PT
- Base to centerline tolerance, +/- .005" (+/- 0.13 mm)
- Expansion - is 3/8" for all size codes
- Dimensions for "D", "P" & "U" based on unmounted condition
- H labyrinth seals standard

All size codes available with type E lip seals & E7 triple lip seals
 For the Selection Guide, Load Ratings and Speed Limits, see the Link-Belt Spherical Roller Bearings Engineering section on pages 135 - 140.

Note: Dimensions subject to change. Certified dimensions of ordered material furnished on request.

EPB22400, EPEB22400

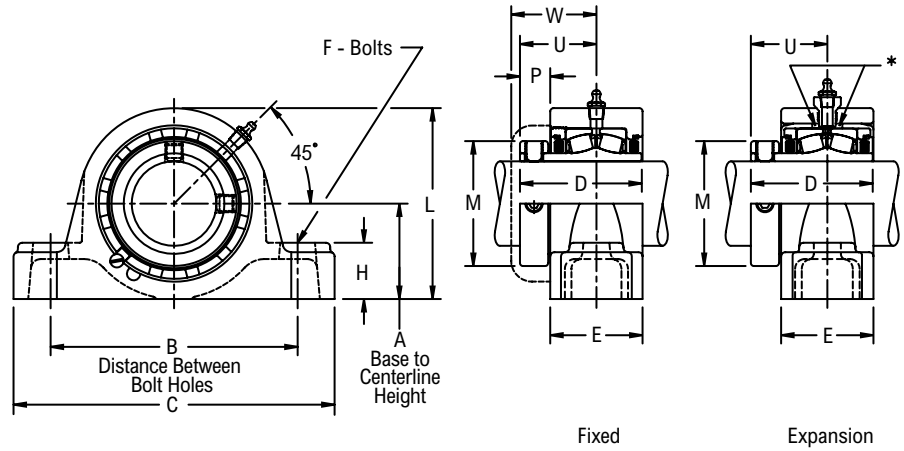
Interchange: EP2BS2, P2BE, SYE, USRBE5000, (E)RPBA, QAP, EP2BTRB



Photo Shows a 2-Bolt Spherical Roller Bearing Pillow Block Unit

Product Features

- Self-aligning type E interchange
- Corrosion-resistant powder coating
- Cast iron housing
- Misalignment capabilities - total of 4°
- Broad range of sealing options
- Factory set clearance & lubrication
- Hardened spring locking collar
- Field interchangeable seals
- Fixed or Expansion - total of 3/8" expansion
- See Features and Benefits for additional info on pages 132 - 133.



Bearing Dimensions

Size Code	Shaft Diameter	Expansion		Fixed		A Base to Centerline Height	B Distance Between Bolt Holes		C	D	E	F Bolts	H	L	M	P	U	W	Approx. Weight	
		Part Number	Part Number	Min	Max															
B424	1 7/16	EPEB22423H	EPB22423H	1 7/8	4 3/4	6	7 3/8	2 7/8	2 1/4	1/2	1 1/8	3 7/8	2 5/16	2 1/32	1 25/32	2 3/16			8.00	
	35.00	EPEB224M35H	EPB224M35H	47.62	120.60	152.40	187.30	73.02	57.20	12.00	28.60	98.40	58.70	16.70	45.20	55.60			3.10	
B428	1 1/2	EPEB224B24H	EPB224B24H	2 1/8	5 1/4	6 1/2	7 7/8	3 1/8	2 1/2	1/2	1 1/4	4 3/8	2 19/32	2 1/32	1 29/32	2 1/4			11.00	
	1 5/8	EPEB22426H	EPB22426H																	
	1 11/16	EPEB22427H	EPB22427H																	
	40.00	EPEB224M40H	EPB224M40H	53.98	133.40	165.10	200.00	79.38	63.50	12.00	31.80	111.10	65.90	16.70	48.40	57.20			5.40	
B432	1 3/4	EPEB224B28H	EPB224B28H	2 1/4	6 1/16	7 1/4	8 7/8	3 1/8	2 1/2	5/8	1 5/16	4 9/16	2 7/8	2 1/32	1 29/32	2 9/32			12.00	
	1 15/16	EPEB22431H	EPB22431H																	
	2	EPEB22432H	EPB22432H																	
	45.00	EPEB224M45H	EPB224M45H																	
	50.00	EPEB224M50H	EPB224M50H	57.15	154.00	184.20	225.40	79.38	63.50	16.00	33.30	115.90	73.00	16.70	48.40	57.90			5.50	
																				5.20
B436	2 3/16	EPEB22435H	EPB22435H	2 1/2	6 9/16	8	9 5/8	3 5/16	2 9/16	5/8	1 1/2	5	3 1/4	2 5/32	2 1/16	2 7/16			15.00	
	55.00	EPEB224M55H	EPB224M55H	63.50	166.70	203.20	244.50	84.14	65.10	16.00	38.10	127.00	82.60	19.80	52.40	61.90			6.60	
B440	2 1/4	EPEB224B36H	EPB224B36H	2 3/4	6 15/16	8 3/4	10 1/2	3 1/2	2 11/16	5/8	1 5/8	5 1/2	3 9/16	2 7/32	2 3/16	2 9/16			17.00	
	2 7/16	EPEB22439H	EPB22439H																	
	2 1/2	EPEB22440H	EPB22440H																	
	60.00	EPEB224M60H	EPB224M60H	69.85	176.20	222.20	266.70	88.90	68.30	16.00	41.30	139.70	90.50	21.40	55.60	65.10			8.20	
B448	2 11/16	EPEB22443H	EPB22443H	3 1/8	7 13/16	9 3/4	11 13/16	4	3 3/16	3/4	1 7/8	6 5/16	4 1/16	2 7/32	2 7/16	2 25/32			28.00	
	2 3/4	EPEB22444H	EPB22444H																	
	2 15/16	EPEB22447H	EPB22447H																	
	3	EPEB22448H	EPB22448H																	
	65.00	EPEB224M65H	EPB224M65H																	
	70.00	EPEB224M70H	EPB224M70H	79.38	198.40	247.60	300.00	101.60	81.00	20.00	47.60	160.30	103.20	21.40	61.90	70.60			13.50	
	75.00	EPEB224M75H	EPB224M75H																	13.30
																				12.80
B456	3 3/16	EPEB22451H	EPB22451H	3 3/4	9 5/16	11 5/16	13 13/16	4 3/8	3 1/2	7/8	2 1/4	7 1/2	4 29/32	1 5/16	2 21/32	3			43.00	
	3 7/16	EPEB22455H	EPB22455H																	
	3 1/2	EPEB22456H	EPB22456H																	
	80.00	EPEB224M80H	EPB224M80H																	
	85.00	EPEB224M85H	EPB224M85H	95.25	236.50	287.30	350.80	111.12	88.90	24.00	57.20	190.50	124.60	23.80	67.50	76.20			20.00	
																				19.50

Additional Notes

- Please call 1-866-REXNORD for availability
- Lubrication fitting tap size, 1/8" PT
- Base to centerline tolerance, +/- .005" (+/- 0.13 mm)
- Expansion - is 3/8" for all size codes
- H labyrinth seals standard
- All size codes available with type E lip seals & E7 triple lip seals

For the Selection Guide, Load Ratings and Speed Limits, see the Link-Belt Spherical Roller Bearings Engineering section on pages 135 - 140.

Note: Dimensions subject to change. Certified dimensions of ordered material furnished on request.

EPB22400F, EPEB22400F

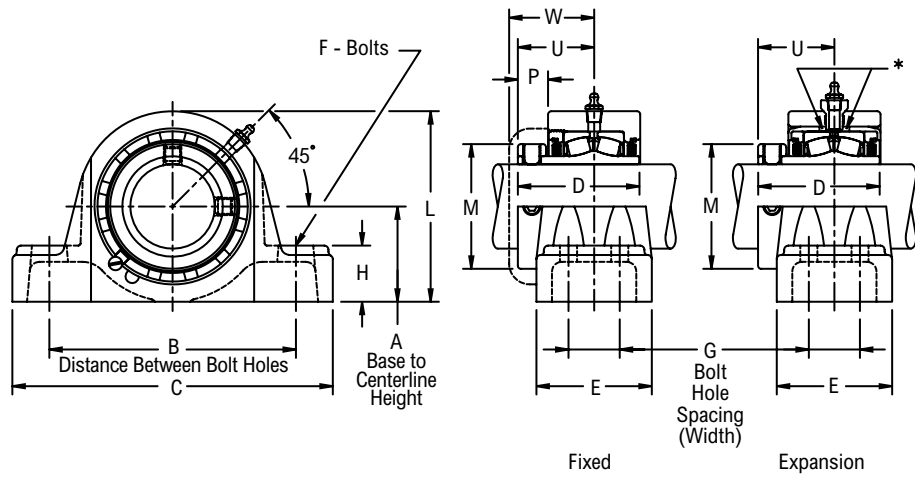
Interchange: EP4BS2, P4BE, FSYE, (E)RPBA, QAPR, EP4BTRB



Photo Shows a 4-Bolt Spherical Roller Bearing Pillow Block Unit

Product Features

- Self-aligning type E interchange
- Corrosion-resistant powder coating
- Cast iron housing
- Misalignment capabilities - total of 4°
- Broad range of sealing options
- Factory set clearance & lubrication
- Hardened spring locking collar
- Field interchangeable seals
- Fixed or Expansion - total of 3/8" expansion
- See Features and Benefits for additional info on pages 132 - 133.



Bearing Dimensions

Size Code	Shaft Diameter	Expansion		Fixed		A Base to Centerline Height	B Distance Between Bolt Holes		G Bolt Hole Spacing (Width)	C	D	E	F Bolts	H	L	M	P	U	W	Approx. Weight													
		Part Number	Part Number	Min	Max																												
B440	2 1/4	EPEB224B36FH	EPB224B36FH	2 3/4	6 15/16	8 3/4	1 7/8	10 1/2	3 1/2	3 5/8	5/8	1 5/8	5 1/2	3 9/16	27/32	2 3/16	2 9/16	21.00															
	2 7/16	EPEB22439FH	EPB22439FH																20.00														
	2 1/2	EPEB22440FH	EPB22440FH																20.00														
	60.00	EPEB224M60FH	EPB224M60FH																69.85	176.20	222.20	47.60	266.70	88.90	92.10	16.00	41.30	139.70	90.50	21.4	55.60	65.1	8.80
B448	2 11/16	EPEB22443FH	EPB22443FH	3 1/8	7 13/16	9 7/8	2 1/8	11 13/16	4	4 1/4	5/8	1 7/8	6 5/16	4 1/16	27/32	2 7/16	2 25/32	31.00															
	2 3/4	EPEB22444FH	EPB22444FH																29.00														
	2 15/16	EPEB22447FH	EPB22447FH																29.00														
	3	EPEB22448FH	EPB22448FH																29.00														
	65.00	EPEB224M65FH	EPB224M65FH																79.38	198.40	250.80	54.00	300.00	101.60	108.00	16.00	47.60	160.30	103.20	21.4	61.90	70.6	14.00
	70.00	EPEB224M70FH	EPB224M70FH																13.80														
75.00	EPEB224M75FH	EPB224M75FH	13.30																														
B456	3 3/16	EPEB22451FH	EPB22451FH	3 3/4	9 5/16	11 5/16	2 3/8	13 13/16	4 3/8	4 3/4	3/4	2 1/4	7 1/2	4 29/32	15/16	2 21/32	3	47.00															
	3 7/16	EPEB22455FH	EPB22455FH																46.00														
	3 1/2	EPEB22456FH	EPB22456FH																45.00														
	80.00	EPEB224M80FH	EPB224M80FH																95.25	236.50	290.50	60.30	350.80	111.12	120.60	20.00	57.20	190.50	124.60	23.8	67.50	76.2	21.30
85.00	EPEB224M85FH	EPB224M85FH	20.80																														
B464	3 11/16	EPEB22459FH	EPB22459FH	4 1/4	11 7/8	13	2 1/4	15 1/4	5 1/16	4 1/2	3/4	2 5/8	8 1/2	5 5/8	1 1/16	3 7/16	3 7/16	69.00															
	3 15/16	EPEB22463FH	EPB22463FH																67.00														
	4	EPEB22464FH	EPB22464FH																66.00														
	90.00	EPEB224M90FH	EPB224M90FH																107.95	301.60	330.20	57.20	387.40	128.59	114.30	20.00	66.70	215.90	142.90	27.0	77.80	87.3	32.10
100.00	EPEB224M100FH	EPB224M100FH	30.30																														

Additional Notes

- Please call 1-866-REXNORD for availability
- Lubrication fitting tap size, 1/8" PT
- Base to centerline tolerance, +/- .005" (+/- 0.13 mm)
- Expansion - is 3/8" for all size codes
- H labyrinth seals standard
- All size codes available with type E lip seals & E7 triple lip seals

For the Selection Guide, Load Ratings and Speed Limits, see the Link-Belt Spherical Roller Bearings Engineering section on pages 135 - 140.

Note: Dimensions subject to change. Certified dimensions of ordered material furnished on request.

EPB22500, EPEB22500, EPB22500F, EPEB22500F

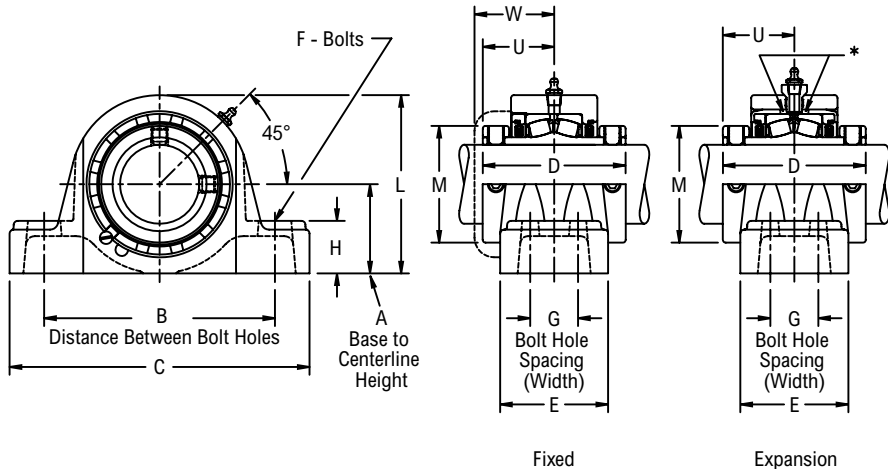
Interchange: (E)RPB, QAAP(F), QAAPR



Photo Shows a 2-Bolt Spherical Roller Bearing Pillow Block Unit

Product Features

- Self-aligning type E interchange
- Corrosion-resistant powder coating
- Cast iron housing
- Misalignment capabilities - total of 4°
- Broad range of sealing options
- Factory set clearance & lubrication
- Two hardened spring locking collars
- Field interchangeable seals
- Fixed or Expansion - total of 3/8" expansion
- See Features and Benefits for additional info on pages 132 - 133.



Bearing Dimensions

Size Code	Shaft Diameter	Expansion		Fixed		A Base to Centerline Height	B Distance Between Bolt Holes		G Bolt Hole Spacing (Width)	C	D	E	F Bolts	H	L	M	U	W	Approx. Weight	
		Part Number	Part Number	Min	Max															
Two-Bolt Pillow Block																				
B524	1 7/16	EPEB22523H	EPB22523H	1 7/8	4 3/4	6	-	7 3/8	3 9/16	2 1/4	1/2	1 1/8	3 7/8	2 5/16	1 25/32	2 3/16	8.00			
B528	1 11/16	EPEB22527H	EPB22527H	2 1/8	5 1/2	6 1/2	-	7 7/8	3 13/16	2 1/2	1/2	1 1/4	4 3/8	2 19/32	1 29/32	2 1/4	12.00			
B531	1 15/16	EPEB22531H	EPB22531H	2 1/4	6 1/16	7 1/4	-	8 7/8	3 13/16	2 1/2	5/8	1 5/16	4 9/16	2 7/8	1 29/32	2 9/32	13.00			
B536	2 3/16	EPEB22535H	EPB22535H	2 1/2	6 9/16	8	-	9 5/8	4 1/8	2 9/16	5/8	1 1/2	5	3 1/4	2 1/16	2 7/16	16.00			
B540	2 7/16	EPEB22539H	EPB22539H	2 3/4	6 15/16	8 3/4	-	10 1/2	4 3/8	2 11/16	5/8	1 5/8	5 1/2	3 9/16	2 3/16	2 9/16	18.00			
B548	2 11/16	EPEB22543H	EPB22543H	3 1/8	7 13/16	9 3/4	-	11 11/16	4 7/8	3 13/16	3/4	1 7/8	6 5/16	4 1/16	2 7/16	2 25/32	31.00			
																		EPEB22547H	EPB22547H	29.00
B556	3 7/16	EPEB22555H	EPB22555H	3 3/4	9 5/16	11 5/16	-	13 13/16	5 5/16	3 1/2	7/8	2 1/4	7 1/2	4 29/32	2 21/32	3	45.00			
Four-Bolt Pillow Block																				
B540	2 7/16	EPEB22539FH	EPB22539FH	2 3/4	6 15/16	8 3/4	1 7/8	10 1/2	4 3/8	3 5/8	5/8	1 5/8	5 1/2	3 9/16	2 3/16	2 9/16	21.00			
B548	2 11/16	EPEB22543FH	EPB22543FH	3 1/8	7 13/16	9 7/8	2 1/8	11 13/16	4 7/8	4 1/4	5/8	1 7/8	6 5/16	4 1/16	2 7/16	2 25/32	33.00			
																		EPEB22547FH	EPB22547FH	31.00
B556	3 7/16	EPEB22555FH	EPB22555FH	3 3/4	9 5/16	11 7/16	2 3/8	13 13/16	5 5/16	4 3/4	3/4	2 1/4	7 1/2	4 29/32	2 21/32	3	48.00			
B564	3 15/16	EPEB22563FH	EPB22563FH	4 1/4	11 7/8	13	2 1/4	15 1/4	6 1/8	4 1/2	3/4	2 5/8	8 5/8	5 5/8	3 1/16	3 7/16	71.00			
																		EPEB22564FH	EPB22564FH	70.00
B572	4 3/16	EPEB22567YFH	EPB22567YFH	4 3/4	12 3/4	14 1/8	2 1/2	16 1/2	6 1/4	4 5/8	3/4	2 3/4	9 3/8	6 3/16	3 1/8	-	92.00			
																		EPEB22571YFH	EPB22571YFH	88.00
																		EPEB22572YFH	EPB22572YFH	87.00
																		110.00	EPEB225M110YFH	EPB225M110YFH
115.00	EPEB225M115YFH	EPB225M115YFH	39.50																	
B580	4 15/16	EPEB22579YFH	EPB22579YFH	5 1/2	14 5/16	16 1/8	2 3/4	18 1/2	7 7/8	5 9/16	7/8	3	11 1/8	7 1/16	3 15/16	-	129.00			
																		EPEB22580YFH	EPB22580YFH	128.00
																		125.00	EPEB225M125YFH	EPB225M125YFH

Additional Notes

- Please call 1-866-REXNORD for availability
- Lubrication fitting tap size, 1/8" PT
- Base to centerline tolerance, +/- .005" (+/- 0.13 mm)
- Expansion - is 3/8" for all size codes
- H labyrinth seals standard
- All size codes available with type E lip seals & E7 triple lip seals

For the Selection Guide, Load Ratings and Speed Limits, see the Link-Belt Spherical Roller Bearings Engineering section on pages 135 - 140.

Note: Dimensions subject to change. Certified dimensions of ordered material furnished on request.

EPB22600, EPEB22600

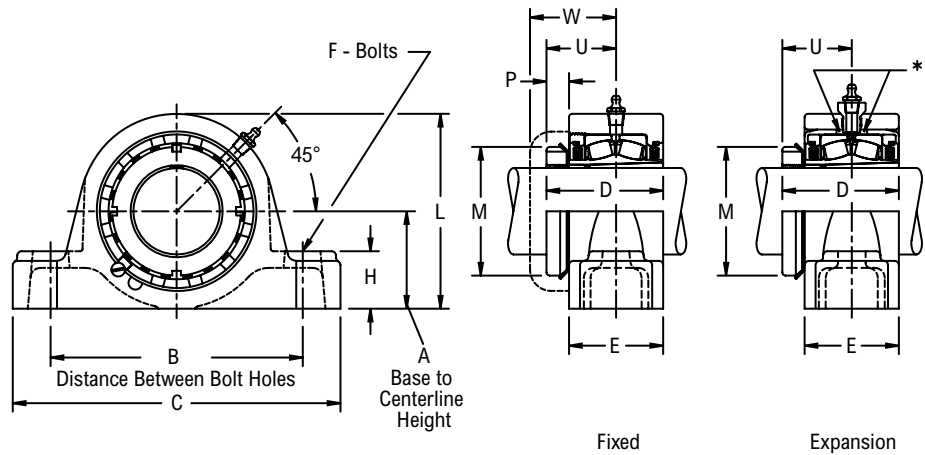
Interchange: EP2BIP, USRBE5000A, QVVP, DVP



Photo Shows a 2-Bolt Spherical Roller Bearing Pillow Block Unit

Product Features

- Self-aligning type E interchange
- Corrosion-resistant powder coating
- Cast iron housing
- Misalignment capabilities - total of 4°
- Broad range of sealing options
- Factory set clearance & lubrication
- Enhanced life mounting style
- Field interchangeable seals
- Fixed or Expansion - total of 3/8" expansion
- See Features and Benefits for additional info on pages 132 - 133.



Fixed

Expansion

Bearing Dimensions

Size Code	Shaft Diameter	Expansion		Fixed		A Base to Centerline Height	B Distance Between Bolt Holes		C	D	E	F Bolts	H	L	M	P	U	W	Approx. Weight
		Part Number	Part Number	Min	Max														
B624	1 7/16	EPEB22623H	EPB22623H	1 7/8	4 3/4	6	7 3/8	2.71	2 1/4	1 1/2	1 1/8	3 7/8	2 1/4	1 1/2	1 39/64	2 3/16	8.00		
B631	1 15/16	EPEB22631H	EPB22631H	2 1/4	6 1/16	7 1/4	8 7/8	3.08	2 1/2	5/8	1 5/16	4 9/16	2 31/32	39/64	1 55/64	2 9/32	12.00		
B635	2 3/16	EPEB22635H	EPB22635H	2 1/2	6 9/16	8	9 5/8	3.16	2 9/16	5/8	1 1/2	5	3 5/32	5/8	1 29/32	2 7/16	15.00		
B639	2 7/16	EPEB22639H	EPB22639H	2 3/4	6 15/16	8 3/4	10 1/2	3.28	2 11/16	5/8	1 5/8	5 1/2	3 5/8	45/64	1 31/32	2 9/16	17.00		
B647	2 11/16	EPEB22643H	EPB22643H	3 1/8	7 13/16	9 3/4	11 13/16	3.86	3 3/16	3/4	1 7/8	6 5/16	4 5/32	55/64	2 19/64	2 25/32	29.00		
	2 15/16	EPEB22647H	EPB22647H															27.00	
B655	3 7/16	EPEB22655H	EPB22655H	3 3/4	9 5/16	11 5/16	13 13/16	4.29	3 1/2	7/8	2 1/4	7 1/2	4 15/16	7/8	2 37/64	3	43.00		

Additional Notes

- Please call 1-866-REXNORD for availability
- Lubrication fitting tap size, 1/8" PT
- Base to centerline tolerance, +/- .005" (+/- 0.13 mm)
- Expansion - is 3/8" for all size codes
- Dimensions for "D", "P" & "U" based on unmounted condition
- H labyrinth seals standard

All size codes available with type E lip seals & E7 triple lip seals
 For the Selection Guide, Load Ratings and Speed Limits, see the Link-Belt Spherical Roller Bearings Engineering section on pages 135 - 140.

Note: Dimensions subject to change. Certified dimensions of ordered material furnished on request.

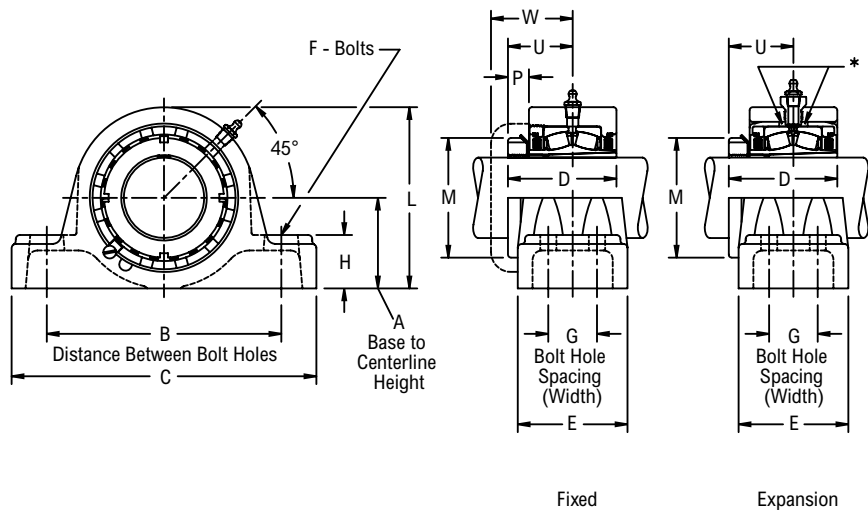
EPB22600F, EPEB22600F
Interchange: EP4BIP, QVVP



Photo Shows a 4-Bolt Spherical Roller Bearing Pillow Block Unit

Product Features

- Self-aligning type E interchange
- Corrosion-resistant powder coating
- Cast iron housing
- Misalignment capabilities - total of 4°
- Broad range of sealing options
- Factory set clearance & lubrication
- Enhanced life mounting style
- Field interchangeable seals
- Fixed or Expansion - total of 3/8" expansion
- See Features and Benefits for additional info on pages 132 - 133.



Bearing Dimensions

Size Code	Shaft Diameter	Expansion		Fixed		A Base to Centerline Height	B Distance Between Bolt Holes		G Bolt Hole Spacing (Width)	C	D	E	F Bolts	H	L	M	P	U	W	Approx. Weight
		Part Number	Part Number	Min	Max															
B639	2 7/16	EPEB22639FH	EPB22639FH	2 3/4	6 15/16	8 3/4	1 7/8	10 1/2	3.28	3 5/8	5/8	1 5/8	5 1/2	3 5/8	5/8	1 31/32	2 9/16	20.00		
B647	2 11/16	EPEB22643FH	EPB22643FH	3 1/8	7 13/16	9 7/8	2 1/8	11 13/16	3.86	4 1/4	5/8	1 7/8	6 5/16	4 5/32	45/64	2 19/64	2 25/32	31.00		
	2 15/16	EPEB22647FH	EPB22647FH	3 3/4	9 5/16	11 5/16	2 3/8	13 13/16	4.29	4 3/4	3/4	2 1/4	7 1/2	4 15/16	55/64	2 37/64	3	29.00		
B655	3 7/16	EPEB22655FH	EPB22655FH	3 3/4	9 5/16	11 5/16	2 3/8	13 13/16	4.29	4 3/4	3/4	2 1/4	7 1/2	4 15/16	55/64	2 37/64	3	46.00		

Additional Notes

- Please call 1-866-REXNORD for availability
- Lubrication fitting tap size, 1/8" PT
- Base to centerline tolerance, +/- .005" (+/- 0.13 mm)
- Expansion - is 3/8" for all size codes
- Dimensions for "D", "P" & "U" based on unmounted condition
- H labyrinth seals standard

- All size codes available with type E lip seals & E7 triple lip seals
- For the Selection Guide, Load Ratings and Speed Limits, see the Link-Belt Spherical Roller Bearings Engineering section on pages 135 - 140.
- Note: Dimensions subject to change. Certified dimensions of ordered material furnished on request.

FB22400, FEB22400

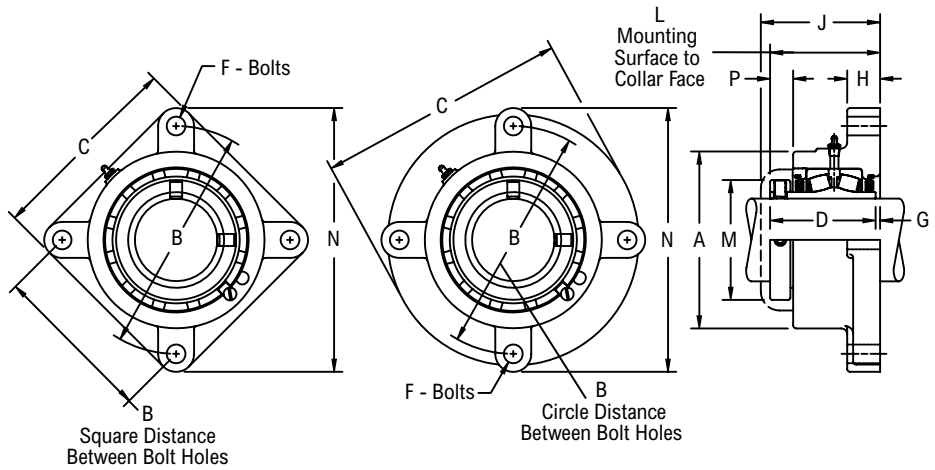
Interchange: F4RS2, F4SS2, FYR, USFB5000, QAFY, QAFL



Photo Shows a 4-Bolt Spherical Roller Bearing Flanged Unit

Product Features

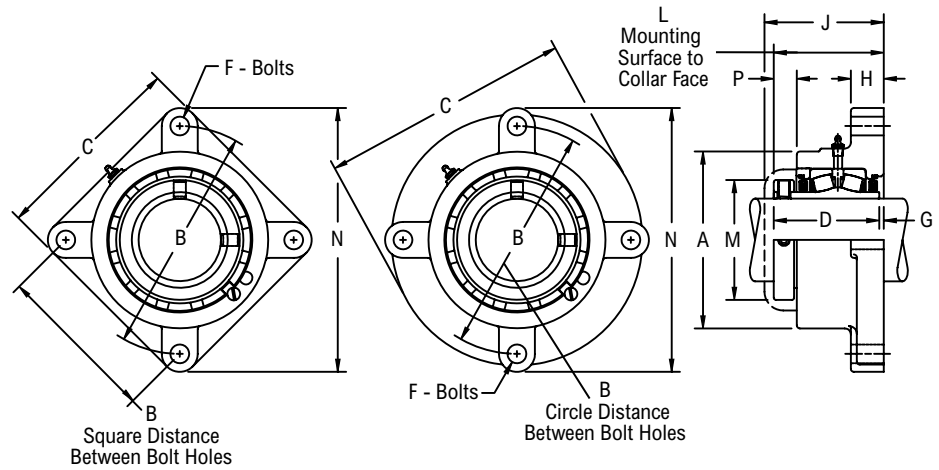
- Corrosion-resistant powder coating
- Cast iron housing
- Misalignment capabilities - total of 4°
- Broad range of sealing options
- Factory set clearance & lubrication
- Hardened spring locking collar
- Field interchangeable seals
- Fixed or Expansion - total of 3/8 in expansion
- See Features and Benefits for additional info on pages 132 - 133.



Bearing Dimensions

Size Code	Shaft Diameter	Expansion		Fixed		B		L	C	D	F	G	H	J	M	N	P	Approx. Weight
		Part Number	A	Part Number	A	Square	Circle											
3-Bolt Round																		
B416	1	-	-	FB22416H	2 ⁷ / ₈	-	4 ¹ / ₈	2 ¹⁹ / ₃₂	4 ³ / ₄	2 ⁹ / ₁₆	3/8	1/32	9/16	2 ¹⁵ / ₁₆	1 ³ / ₄	5 ¹ / ₈	17/32	3.00
	25.00	-	-	FB224M25H	73.00	-	104.78	65.90	120.60	65.09	10.00	0.80	14.30	74.60	44.40	130.20	13.50	1.30
B420	1 ³ / ₁₆	FEB22419H	3 ¹ / ₂	FB22419H	3 ¹ / ₈	-	4 ¹ / ₂	2 ²³ / ₃₂	5 ¹ / ₈	2 ¹¹ / ₁₆	3/8	1/32	19/32	3 ¹ / ₁₆	1 ³¹ / ₃₂	5 ¹ / ₂	17/32	6.00
	1 ¹ / ₄	FEB22420H	3 ¹ / ₂	FB22420H	79.40	-	114.30	69.00	130.20	68.26	10.00	0.80	15.10	77.80	50.00	139.70	13.50	2.40
B424	1 ⁷ / ₁₆	FEB22423H	3 ³ / ₄	FB22423H	3 ⁷ / ₁₆	-	5	2 ²⁹ / ₃₂	5 ⁷ / ₈	2 ⁷ / ₈	1/2	1/32	5/8	3 ⁵ / ₁₆	2 ⁵ / ₁₆	6 ¹ / ₄	2 ¹ / ₃₂	7.00
	1 ¹ / ₂	FEB22424H	3 ³ / ₄	FB22424H	87.30	-	127.00	73.80	149.20	73.02	12.00	0.80	15.90	84.10	58.70	158.80	16.70	3.20
35.00	FEB224M35H	95.20	FB224M35H	87.30	-	127.00	73.80	149.20	73.02	12.00	0.80	15.90	84.10	58.70	158.80	16.70	3.20	
4-Bolt Round																		
B428	1 ⁵ / ₈	FEB22426H	4 ¹ / ₄	FB22426H	3 ¹⁵ / ₁₆	3 ⁵⁷ / ₆₄	5 ¹ / ₂	3 ⁵ / ₃₂	6 ³ / ₈	3 ¹ / ₈	1/2	1/32	5/8	3 ¹ / ₂	2 ¹⁹ / ₃₂	6 ³ / ₄	2 ¹ / ₃₂	9.00
	1 ¹¹ / ₁₆	FEB22427H	4 ¹ / ₄	FB22427H	100.00	98.83	139.70	80.20	161.90	79.38	12.00	0.80	15.90	88.90	65.90	171.40	16.70	4.30
B432	1 ³ / ₄	FEB22428H	4 ¹ / ₂	FB22428H	4 ¹ / ₄	4 ¹ / ₁₆	5 ³ / ₄	3 ³ / ₁₆	6 ¹¹ / ₁₆	3 ¹ / ₈	1/2	1/16	11/16	3 ⁹ / ₁₆	2 ⁷ / ₈	7	2 ¹ / ₃₂	10.00
	40.00	FEB224M40H	108.00	FB224M40H	100.00	103.17	146.05	81.00	169.90	79.38	12.00	1.60	17.50	90.50	73.00	177.80	16.70	5.00
B436	1 ¹⁵ / ₁₆	FEB22431H	4 ¹ / ₂	FB22431H	4 ¹ / ₄	4 ¹ / ₁₆	5 ³ / ₄	3 ³ / ₁₆	6 ¹¹ / ₁₆	3 ¹ / ₈	1/2	1/16	11/16	3 ⁹ / ₁₆	2 ⁷ / ₈	7	2 ¹ / ₃₂	4.70
	2	FEB22432H	4 ¹ / ₂	FB22432H	108.00	103.17	146.05	81.00	169.90	79.38	12.00	1.60	17.50	90.50	73.00	177.80	16.70	5.00
B440	2 ³ / ₁₆	FEB22435H	4 ⁷ / ₈	FB22435H	4 ⁷ / ₈	4 ¹ / ₂	6 ³ / ₈	3 ¹³ / ₃₂	7 ³ / ₈	3 ⁵ / ₁₆	5/8	3/32	11/16	3 ²⁵ / ₃₂	3 ¹ / ₄	7 ³ / ₄	2 ⁵ / ₃₂	14.00
	2 ¹ / ₄	FEB22436H	4 ⁷ / ₈	FB22436H	123.80	123.80	114.30	161.92	187.30	84.14	16.00	2.40	17.50	96.00	82.60	196.80	19.80	6.50
B444	2 ⁷ / ₁₆	FEB22439H	5 ³ / ₈	FB22439H	5 ³ / ₈	4 ⁴⁹ / ₆₄	6 ³ / ₄	3 ¹⁹ / ₃₂	7 ³ / ₄	3 ¹ / ₂	5/8	3/32	3/4	3 ³¹ / ₃₂	3 ⁹ / ₁₆	8 ¹ / ₈	2 ⁷ / ₃₂	17.00
	2 ¹ / ₂	FEB22440H	5 ³ / ₈	FB22440H	136.50	136.50	121.06	171.45	196.80	88.90	16.00	2.40	19.00	100.80	90.50	206.40	21.40	7.90
B448	2 ¹¹ / ₁₆	FEB22443H	6 ¹ / ₄	FB22443H	6 ¹ / ₄	5 ⁹ / ₁₆	7 ⁷ / ₈	4 ³ / ₃₂	9 ¹ / ₈	4	3/4	3/32	7/8	4 ⁷ / ₁₆	4 ¹ / ₁₆	9 ¹ / ₂	2 ⁷ / ₃₂	28.00
	2 ³ / ₄	FEB22444H	6 ¹ / ₄	FB22444H	158.80	158.80	141.27	200.02	231.80	101.60	20.00	2.40	22.20	112.70	103.20	241.30	21.40	27.00
B456	2 ¹⁵ / ₁₆	FEB22447H	6 ¹ / ₄	FB22447H	158.80	158.80	141.27	200.02	231.80	101.60	20.00	2.40	22.20	112.70	103.20	241.30	21.40	26.00
	3	FEB22448H	6 ¹ / ₄	FB22448H	158.80	158.80	141.27	200.02	231.80	101.60	20.00	2.40	22.20	112.70	103.20	241.30	21.40	26.00
B456	3 ³ / ₁₆	FEB22451H	7 ³ / ₈	FB22451H	187.30	187.30	170.64	241.30	214.31	111.12	20.00	6.40	25.40	124.60	124.60	290.50	23.80	12.70
	3 ¹ / ₂	FEB22456H	7 ³ / ₈	FB22456H	187.30	187.30	170.64	241.30	214.31	111.12	20.00	6.40	25.40	124.60	124.60	290.50	23.80	12.50
B456	3 ¹ / ₂	FEB22456H	7 ³ / ₈	FB22456H	187.30	187.30	170.64	241.30	214.31	111.12	20.00	6.40	25.40	124.60	124.60	290.50	23.80	12.50
	80.00	FEB224M80H	187.30	FB224M80H	187.30	187.30	170.64	241.30	214.31	111.12	20.00	6.40	25.40	124.60	124.60	290.50	23.80	12.50
B456	85.00	FEB224M85H	187.30	FB224M85H	187.30	187.30	170.64	241.30	214.31	111.12	20.00	6.40	25.40	124.60	124.60	290.50	23.80	12.50
	85.00	FEB224M85H	187.30	FB224M85H	187.30	187.30	170.64	241.30	214.31	111.12	20.00	6.40	25.40	124.60	124.60	290.50	23.80	12.50

Continued...



Continued...

Bearing Dimensions

Size Code	Shaft Diameter	Expansion		Fixed		B Distance Between Bolt Holes		L Mounting Surface to Collar Face	C	D	F Bolts	G	H	J	M	N	P	Approx. Weight
		Part Number	A	Part Number	A	Square	Circle											
4-Bolt Square (continued)																		
B464	3 11/16	FEB22459H	8 3/8	FB22459H	8 1/2	7 19/32	10 3/4	5 7/32	9 3/4	5 1/16	7/8	1/4	1 1/8	5 5/8	5 5/8	12 29/32	1 1/32	59.00
	3 15/16	FEB22463H		FB22463H														57.00
	4	FEB22464H		FB22464H														
	90.00	FEB224M90H	212.70	FB224M90H	215.90													192.88
100.00	FEB224M100H		FB224M100H															25.90

Additional Notes

Please call 1-866-REXNORD for availability
 Lubrication fitting tap size, 1/8 in PT
 Expansion - is 3/8 in for all size codes
 For expansion units, dimensions "G", "L" & "P" are minimum values.
 For maximum values, add 3/8 in
 H labyrinth seals standard

All size codes available with type E lip seals, except E7 in size code B416
 For the Selection Guide, Load Ratings and Speed Limits, see the Link-Belt Spherical Roller Bearings Engineering section on pages 135 - 140.

Note: Dimensions subject to change. Certified dimensions of ordered material furnished on request.

FB22600, FEB22600

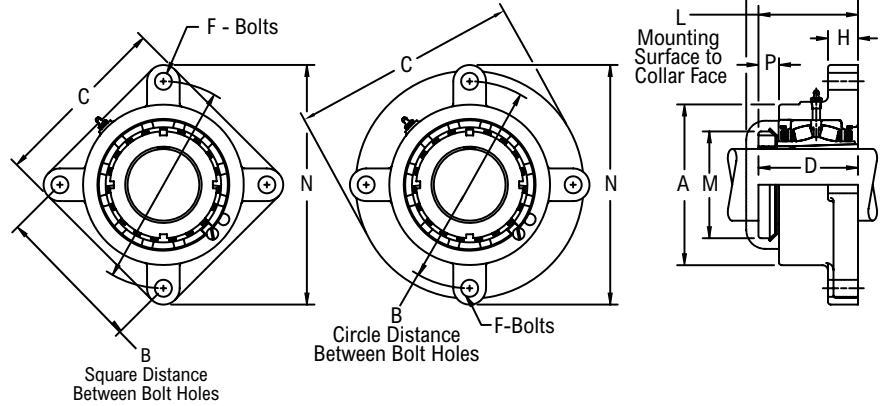
Interchange: F4RIP, F4SIP, USFB5000A, QVFL, QVVFL



Photo Shows a 4-Bolt Spherical Roller Bearing Flanged Unit

Product Features

- Corrosion-resistant powder coating
- Cast iron housing
- Misalignment capabilities - total of 4°
- Broad range of sealing options
- Factory set clearance & lubrication
- Enhanced life mounting style
- Field interchangeable seals
- Fixed or Expansion - total of 3/8 in expansion
- See Features and Benefits for additional info on pages 132 - 133.



Bearing Dimensions

Size Code	Shaft Diameter	Expansion		Fixed		B		L	C	D	F	H	J	M	N	P	Approx. Weight
		Part Number	A	Part Number	A	Distance Between Bolt Holes	Circle										
3-Bolt Round																	
B624	1 7/16	FEB22623H	3 3/4	FB22623H	3 7/16	-	5	2 3/4	5 7/8	2.71	1/2	5/8	3 5/16	2 1/4	6 1/4	1/2	7.00
4-Bolt Round																	
B631	1 15/16	FEB22631H	4 1/2	FB22631H	4 1/4	4 1/16	5 3/4	3 9/64	6 11/16	3.08	1/2	11/16	3 9/16	2 31/32	7	5/8	10.00
B635	2 3/16	FEB22635H	4 7/8	FB22635H	4 7/8	4 1/2	6 3/8	3 17/64	7 3/8	3.16	5/8	11/16	3 25/32	3 5/32	7 3/4	41/64	14.00
B639	2 7/16	FEB22639H	5 3/8	FB22639H	5 3/8	4 49/64	6 3/4	3 3/8	7 3/4	3.28	5/8	3/4	3 31/32	3 5/8	8 1/8	5/8	17.00
B647	2 11/16	FEB22643H	6 1/4	FB22643H	6 1/4	5 9/16	7 7/8	3 31/32	9 1/8	3.86	3/4	7/8	4 7/16	4 5/32	9 1/2	45/64	27.00
	2 15/16	FEB22647H		26.00													
4-Bolt Square																	
B655	3 7/16	FEB22655H	7 3/8	FB22655H	7 3/8	6 23/32	9 1/2	4 31/64	8 7/16	4.29	3/4	1	4 29/32	4 15/16	11 7/16	55/64	39.00
B663	3 15/16	FEB22663H	8 3/8	FB22663H	8 1/2	7 19/32	10 3/4	5 7/64	9 3/4	4.94	7/8	1 1/8	5 5/8	5 7/16	12 29/32	59/64	57.00

Additional Notes

- Please call 1-866-REXNORD for availability
- Lubrication fitting tap size, 1/8 in PT
- Expansion - is 3/8 in for all size codes
- Dimensions for "D", "L" & "P" based on unmounted condition
- For expansion units, dimensions "G", "L" & "P" are minimum values.
- For maximum values, add 3/8 in

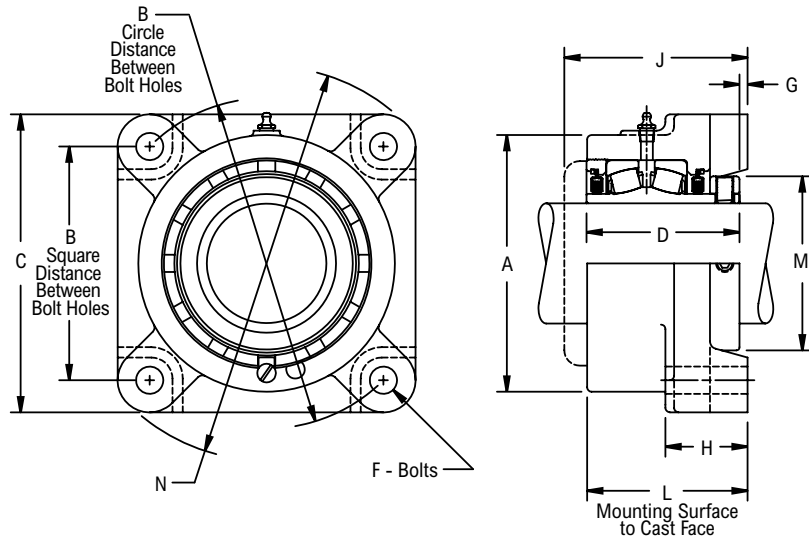
- H labyrinth seals standard
- All size codes available with type E lip seals & E7 triple lip seals
- For the Selection Guide, Load Ratings and Speed Limits, see the Link-Belt Spherical Roller Bearings Engineering section on pages 135 - 140.
- Note: Dimensions subject to change. Certified dimensions of ordered material furnished on request.

EFRB22400

Interchange: EF4BS2, F4BE, FYE, USFBE5000, RFBA, QAF, E4BFTRB



Photo Shows a 4-Bolt Spherical Roller Bearing Flanged Unit



Product Features

- Self aligning type E interchange
- Corrosion-resistant powder coating
- Cast iron housing
- Misalignment capabilities - total of 4°
- Broad range of sealing options
- Factory set clearance & lubrication
- Hardened spring locking collar
- Field interchangeable seals
- See Features and Benefits for additional info on pages 132 - 133.

Bearing Dimensions

Size Code	Shaft Diameter	Part Number	B Distance Between Bolt Holes		L Mounting Surface to Cast Face	A	C	D	F Bolts	G	H	J	M	N	Approx. Weight												
			Square	Circle																							
B424	1 7/16	EFRB22423H	3 1/2	4 61/64	2 31/32	3 11/16	4 5/8	2 7/8	1/2	1/16	1 3/8	4 1/32	2 5/16	6 1/16	8.00												
	35.00	EFRB224M35H	88.90	125.81	75.40	93.70	117.50	73.02	12.00	1.60	34.90	102.40	58.70	154.00	3.40												
B428	1 1/2	EFRB224B24H	4 1/8	5 53/64	3 9/32	4 1/4	5 3/8	3 1/8	1/2	1/8	1 7/16	4 9/32	2 19/32	7 7/32	11.00												
	1 5/8	EFRB22426H													10.00												
	1 11/16	EFRB22427H													10.00												
B432	40.00	EFRB224M40H	104.80	148.03	83.30	108.00	136.50	79.38	12.00	3.20	36.50	108.70	65.90	183.40	5.10												
	1 3/4	EFRB224B28H	4 3/8	6 3/16	3 9/32	4 1/2	5 5/8	3 1/8	1/2	1/8	1 7/16	4 5/16	2 7/8	7 5/16	11.00												
	1 15/16	EFRB22431H													10.00												
	2	EFRB22432H													10.00												
45.00	EFRB224M45H	111.10													157.18	83.30	114.30	142.90	79.38	12.00	3.20	36.50	109.50	73.00	185.70	5.30	
50.00	EFRB224M50H	111.10	157.18	83.30	114.30	142.90	79.38	12.00	3.20	36.50	109.50	73.00	185.70	5.00													
B436	2 3/16	EFRB22435H	4 7/8	6 57/64	3 1/2	5	6 1/4	3 5/16	5/8	1/8	1 9/16	4 5/8	3 1/4	8 9/32	15.00												
	55.00	EFRB224M55H	123.80	175.03	88.90	127.00	158.80	84.14	16.00	3.20	39.70	117.50	82.60	210.30	7.10												
B440	2 1/4	EFRB224B36H	5 3/8	7 19/32	3 23/32	5 1/2	6 7/8	3 1/2	5/8	3/16	1 23/32	4 15/16	3 9/16	8 31/32	18.00												
	2 7/16	EFRB22439H													17.00												
	2 1/2	EFRB22440H													17.00												
	60.00	EFRB224M60H													136.50	192.89	94.50	139.70	174.60	88.90	16.00	4.80	43.70	125.40	90.50	227.80	7.90
B448	2 11/16	EFRB22443H	6	8 31/64	4 7/32	6 1/2	7 3/4	4	3/4	3/16	1 25/32	5 13/32	4 1/16	10 1/8	26.00												
	2 3/4	EFRB22444H													25.00												
	2 15/16	EFRB22447H													24.00												
	3	EFRB22448H													24.00												
	65.00	EFRB224M65H													152.40	215.49	107.20	165.10	196.90	101.60	20.00	4.80	45.20	137.30	103.20	257.20	11.70
	70.00	EFRB224M70H													152.40	215.49	107.20	165.10	196.90	101.60	20.00	4.80	45.20	137.30	103.20	257.20	11.50
75.00	EFRB224M75H	152.40	215.49	107.20	165.10	196.90	101.60	20.00	4.80	45.20	137.30	103.20	257.20	11.00													
B456	3 3/16	EFRB22451H	7	9 59/64	4 21/32	7 3/8	9 1/4	4 3/8	3/4	1/4	1 31/32	5 3/4	4 29/32	11 21/32	42.00												
	3 7/16	EFRB22455H													41.00												
	3 1/2	EFRB22456H													40.00												
	80.00	EFRB224M80H													177.80	251.23	118.30	187.30	235.00	111.12	20.00	6.40	50.00	146.00	124.60	296.10	18.90
85.00	EFRB224M85H	177.80	251.23	118.30	187.30	235.00	111.12	20.00	6.40	50.00	146.00	124.60	296.10	18.40													
B464	3 11/16	EFRB22459H	7 3/4	10 61/64	5 15/32	8 7/8	9 3/4	5 1/16	7/8	1/4	2 7/32	6 5/8	5 5/8	12 31/32	58.00												
	3 15/16	EFRB22463H													56.00												
	4	EFRB22464H													56.00												
	90.00	EFRB224M90H													196.80	278.21	138.90	247.65	247.65	128.59	24.00	6.40	56.40	168.30	142.90	329.40	27.20
100.00	EFRB224M100H	196.80	278.21	138.90	247.65	247.65	128.59	24.00	6.40	56.40	168.30	142.90	329.40	25.40													

Additional Notes

- Please call 1-866-REXNORD for availability
- Lubrication fitting tap size, 1/8 in PT
- H labyrinth seals standard
- All size codes available with type E lip seals & E7 triple lip seals

For the Selection Guide, Load Ratings and Speed Limits, see the Link-Belt Spherical Roller Bearings Engineering section on pages 135 - 140.

Note: Dimensions subject to change. Certified dimensions of ordered material furnished on request.

EFB22500

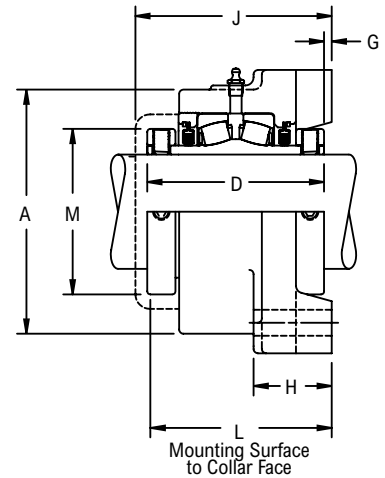
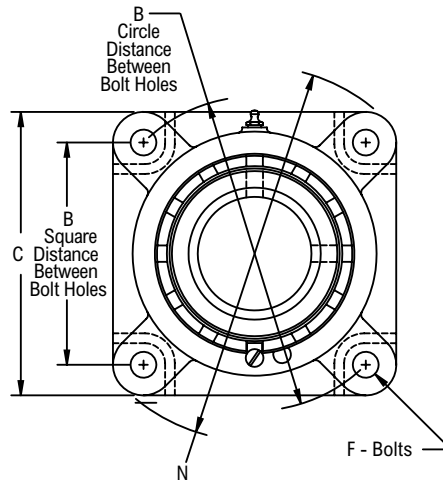
Interchange: RFB, QAAF



Photo Shows a 4-Bolt Spherical Roller Bearing Flanged Unit

Product Features

- Self aligning type E interchange
- Corrosion-resistant powder coating
- Cast iron housing
- Misalignment capabilities - total of 4°
- Broad range of sealing options
- Factory set clearance & lubrication
- Two hardened spring locking collars
- Field interchangeable seals
- See Features and Benefits for additional info on pages 132 - 133.



Bearing Dimensions

Size Code	Shaft Diameter	Part Number	B Distance Between Bolt Holes		L Mounting Surface to Collar Face	A	C	D	F Bolts	G	H	J	M	N	Approx. Weight
			Square	Circle											
B524	1 7/16	EFB22523H	3 1/2	4 61/64	3 5/8	3 11/16	4 5/8	3 9/16	1/2	1/16	1 3/8	4 1/32	2 5/16	6 1/16	8.00
B528	1 11/16	EFB22527H	4 1/8	5 53/64	3 15/16	4 1/4	5 3/8	3 13/16	1/2	1/8	1 7/16	4 9/32	2 19/32	7 7/32	11.00
B531	1 15/16	EFB22531H	4 3/8	6 3/16	3 15/16	4 1/2	5 5/8	3 13/16	1/2	1/8	1 7/16	4 5/16	2 7/8	7 5/16	12.00
B536	2 3/16	EFB22535H	4 7/8	6 57/64	4 1/4	5	6 1/4	4 1/8	5/8	1/8	1 9/16	4 5/8	3 1/4	8 9/32	16.00
B540	2 7/16	EFB22539H	5 3/8	7 19/32	4 9/16	5 1/2	6 7/8	4 3/8	5/8	3/16	1 23/32	4 15/16	3 9/16	8 31/32	18.00
B548	2 11/16	EFB22543H	6	8 31/64	5 1/16	6 1/2	7 3/4	4 7/8	3/4	3/16	1 25/32	5 13/16	4 1/16	10 1/8	28.00
	2 15/16	EFB22547H													26.00
B556	3 7/16	EFB22555H	7	9 59/64	5 13/32	7 3/8	9 1/4	5 5/16	3/4	1/4	1 31/32	5 3/4	4 29/32	11 21/32	44.00
B564	3 15/16	EFB22563H	7 3/4	10 61/64	6 7/32	8 7/8	10 1/4	6 1/8	7/8	1/4	2 7/32	6 5/8	5 5/8	12 31/32	60.00
	4	EFB22564H													59.00

Additional Notes

- Please call 1-866-REXNORD for availability
- Lubrication fitting tap size, 1/8 in PT
- H labyrinth seals standard
- All size codes available with type E lip seals & E7 triple lip seals
- For the Selection Guide, Load Ratings and Speed Limits, see the Link-Belt Spherical Roller Bearings Engineering section on pages 135 - 140.

Note: Dimensions subject to change. Certified dimensions of ordered material furnished on request.

EFB22600

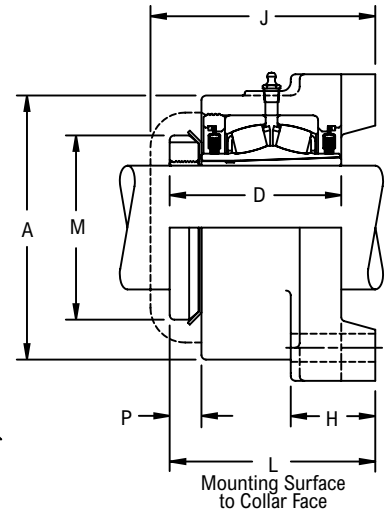
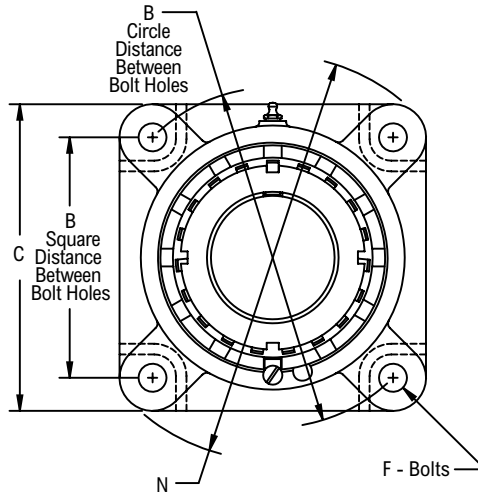
Interchange: EF4BIP, USFBE5000A, QVF, QVVF, DVF



Photo Shows a 4-Bolt Spherical Roller Bearing Flanged Unit

Product Features

- Self aligning type E interchange
- Corrosion-resistant powder coating
- Cast iron housing
- Misalignment capabilities - total of 4°
- Broad range of sealing options
- Factory set clearance & lubrication
- Enhanced life mounting style
- Field interchangeable seals
- See Features and Benefits for additional info on pages 132 - 133.



Bearing Dimensions

Size Code	Shaft Diameter	Part Number	B Distance Between Bolt Holes		L Mounting Surface to Collar Face	A	C	D	F Bolts	H	J	M	N	P	Approx. Weight
			Square	Circle											
B624	1 7/16	EFB22623H	3 1/2	4 61/64	3 29/64	3 11/16	4 5/8	2.71	1/2	1 3/8	4 1/32	2 1/4	6 1/16	31/64	8.00
B631	1 15/16	EFB22631H	4 3/8	6 3/16	3 57/64	4 1/2	5 5/8	3.08	1/2	1 7/16	4 5/16	2 31/32	7 5/16	39/64	11.00
B635	2 3/16	EFB22635H	4 7/8	6 57/64	4 3/32	5	6 1/4	3.16	5/8	1 9/16	4 5/8	3 5/32	8 9/32	5/8	15.00
B639	2 7/16	EFB22639H	5 3/8	7 19/32	4 11/32	5 1/2	6 7/8	3.28	5/8	1 23/32	4 15/16	3 5/8	8 31/32	5/8	17.00
B647	2 11/16	EFB22643H	6	8 31/64	4 59/64	6 1/2	7 3/4	3.86	3/4	1 25/32	5 13/32	4 5/32	10 1/8	45/64	25.00
	2 15/16	EFB22647H													24.00
B655	3 7/16	EFB22655H	7	9 59/64	5 21/64	7 3/8	9 1/4	4.29	3/4	1 31/32	5 3/4	4 15/16	11 21/32	55/64	41.00
B663	3 15/16	EFB22663H	7 3/4	10 61/64	6 7/64	8 7/8	10 1/4	4.94	7/8	2 7/32	6 5/8	5 7/16	12 31/32	59/64	56.00

Additional Notes

- Please call 1-866-REXNORD for availability
- Lubrication fitting tap size, 1/8 in PT
- Dimensions for "D", "L" & "P" based on unmounted condition
- H labyrinth seals standard
- All size codes available with type E lip seals & E7 triple lip seals

For the Selection Guide, Load Ratings and Speed Limits, see the Link-Belt Spherical Roller Bearings Engineering section on pages 135 - 140.

Note: Dimensions subject to change. Certified dimensions of ordered material furnished on request.

FBB22400

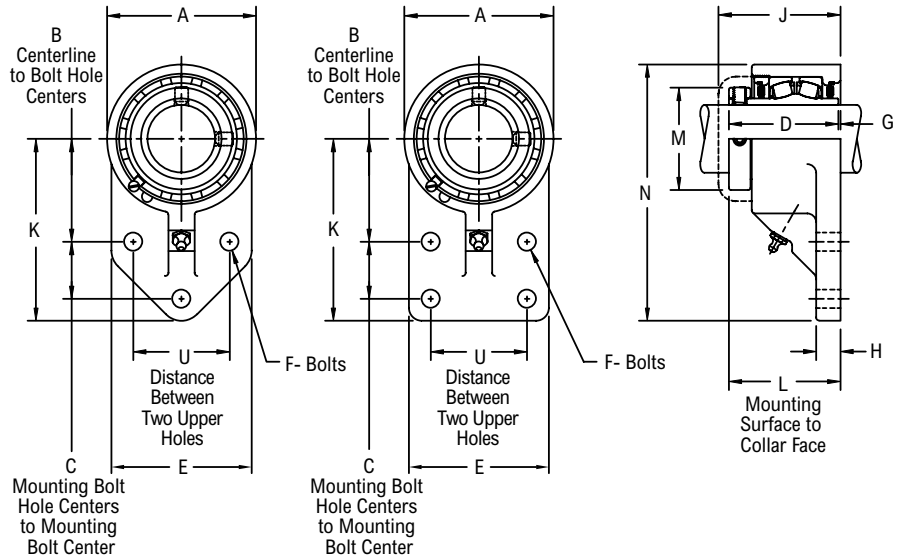
Interchange: USFB5000



Photo Shows a 4-Bolt Spherical Roller Bearing Flanged Bracket Unit with High-Test Iron Housing

Product Features

- Corrosion-resistant powder coating
- High test iron housing
- Misalignment capabilities - total of 4°
- Broad range of sealing options
- Factory set clearance & lubrication
- Hardened spring locking collar
- Field interchangeable seals
- See Features and Benefits for additional info on pages 132 - 133.



Bearing Dimensions

Size Code	Shaft Diameter	Part Number	B Centerline to Bolt Hole Centers	C Mounting Bolt Hole Centers to Mounting Bolt Center	L Mounting Surface to Collar Face	U Distance Between Two Upper Holes	A	D	E	F Bolts	G	H	J	K	M	N	Approx. Weight
3-Bolt																	
B424	1 7/16	FBB22423H	2 3/8	1 1/4	2 29/32	2	3 7/16	2 7/8	3 1/4	1/2	1/32	5/8	3 5/16	4 1/4	2 5/16	5 31/32	6.40
	1 1/2	FBB22424H															
	35.00	FBB224M35H	60.30	31.80	73.80	50.80	87.30	73.02	82.60	12.00	0.80	15.90	84.10	108.00	58.70	151.60	2.90
B432	1 15/16	FBB22431H	2 15/16	1 5/8	3 3/16	2 3/4	4 1/4	3 1/8	4	1/2	1/16	11/16	3 9/16	5 3/16	2 7/8	7 5/16	10.00
	2	FBB22432H															
	45.00	FBB224M45H															
	50.00	FBB224M50H															4.30
4-Bolt																	
B440	2 7/16	FBB22439H	3 3/4	1 3/4	3 19/32	3	5 3/8	3 1/2	4 7/8	5/8	3/32	3/4	3 31/32	6 1/4	3 9/16	8 15/16	17.50
	2 1/2	FBB22440H															
	60.00	FBB224M60H	95.20	44.40	91.30	76.20	136.50	88.90	123.80	16.00	2.40	19.00	100.80	158.80	90.50	227.00	8.10
B448	2 11/16	FBB22443H	3 7/8	2 1/4	4 3/32	4	6 1/4	4	5 3/4	3/4	3/32	7/8	4 7/16	7	4 1/16	10 1/8	30.00
	2 3/4	FBB22444H															
	2 15/16	FBB22447H															
	3	FBB22448H															
	65.00	FBB224M65H															
70.00	FBB224M70H																13.50
	75.00	FBB224M75H															12.80

Additional Notes

- Please call 1-866-REXNORD for availability
- Lubrication fitting tap size: for size code B424, 1/4 in-28 UNF; for all other size codes, 1/8 in PT
- H labyrinth seals standard
- All size codes available with type E lip seals & E7 triple lip seals

For the Selection Guide, Load Ratings and Speed Limits, see the Link-Belt Spherical Roller Bearings Engineering section on pages 135 - 140.

Note: Dimensions subject to change. Certified dimensions of ordered material furnished on request.

FBB22600

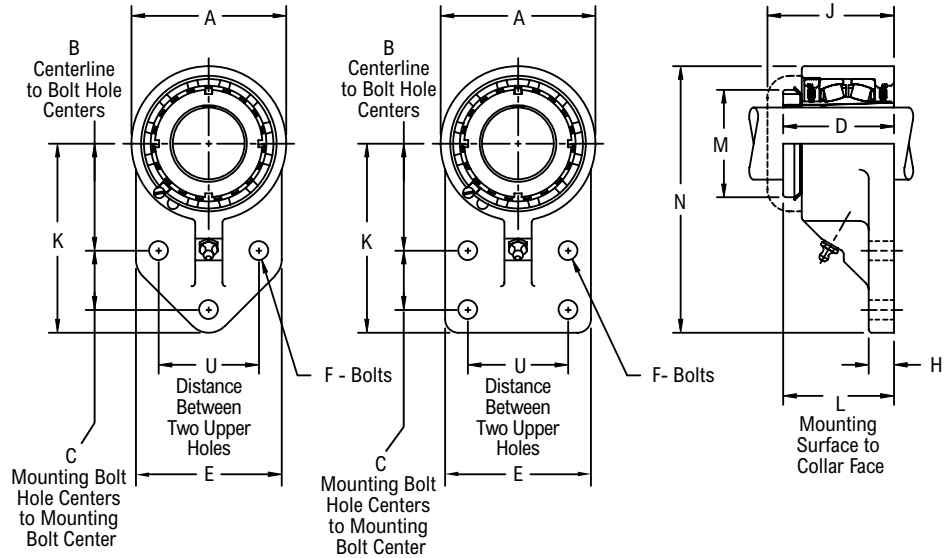
Interchange: USFB5000A



Photo Shows a 4-Bolt Spherical Roller Bearing Flanged Bracket Unit with High-Test Iron Housing

Product Features

- Corrosion-resistant powder coating
- High test iron housing
- Misalignment capabilities - total of 4°
- Broad range of sealing options
- Factory set clearance & lubrication
- Enhanced life mounting style
- Field interchangeable seals
- See Features and Benefits for additional info on pages 132 - 133.



Bearing Dimensions

Size Code	Shaft Diameter	Part Number	B Centerline to Bolt Hole Centers	C Mounting Bolt Hole Centers to Mounting Bolt Center	L Mounting Surface to Collar Face	U Distance Between Two Upper Holes	A	D	E	F Bolts	H	J	K	M	N	Approx. Weight
3-Bolt																
B624	1 ⁷ / ₁₆	FBB22623H	2 ³ / ₈	1 ¹ / ₄	2 ³ / ₄	2	3 ⁷ / ₁₆	2.71	3 ¹ / ₄	1/2	5/8	3 ⁵ / ₁₆	4 ¹ / ₄	2 ¹ / ₄	5 ³¹ / ₃₂	6.40
B631	1 ¹⁵ / ₁₆	FBB22631H	2 ¹⁵ / ₁₆	1 ⁵ / ₈	3 ⁹ / ₆₄	2 ³ / ₄	4 ¹ / ₄	3.08	4	1/2	11/16	3 ⁹ / ₁₆	5 ³ / ₁₆	2 ³¹ / ₃₂	7 ⁵ / ₁₆	10.00
4-Bolt																
B639	2 ⁷ / ₁₆	FBB22639H	3 ³ / ₄	1 ³ / ₄	3 ³ / ₈	3	5 ³ / ₈	3.16	4 ⁷ / ₈	5/8	3/4	3 ³¹ / ₃₂	6 ¹ / ₄	3 ⁵ / ₃₂	8 ¹⁵ / ₁₆	17.50
B647	2 ¹¹ / ₁₆	FBB22643H	3 ⁷ / ₈	2 ¹ / ₄	3 ⁶¹ / ₆₄	4	6 ¹ / ₄	3.28	5 ³ / ₄	3/4	7/8	4 ⁷ / ₁₆	7	3 ⁵ / ₈	10 ¹ / ₈	30.00
	2 ¹⁵ / ₁₆	FBB22647H														

Additional Notes

- Please call 1-866-REXNORD for availability
- Lubrication fitting tap size: for size code B624, 1/4 in-28 UNF; for all other size codes, 1/8 in PT
- Dimensions for "D" & "L" based on unmounted condition
- H labyrinth seals standard
- All size codes available with type E lip seals & E7 triple lip seals

For the Selection Guide, Load Ratings and Speed Limits, see the Link-Belt Spherical Roller Bearings Engineering section on pages 135 - 140.

Note: Dimensions subject to change. Certified dimensions of ordered material furnished on request.

FCB22400

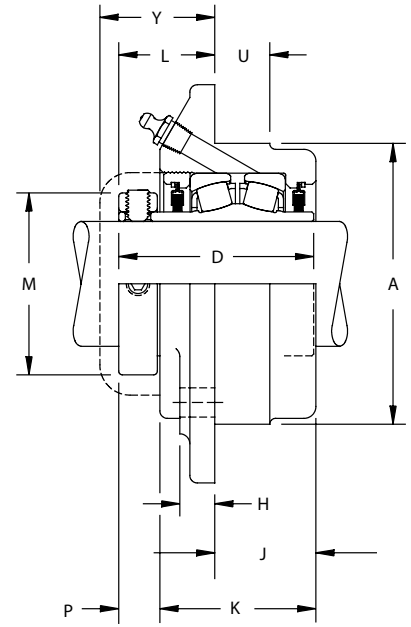
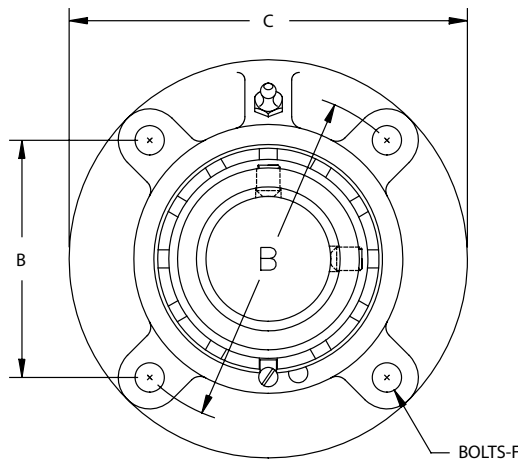
Interchange: FCS2, FCE, FYRP, USFC5000, USFCE5000, RPPA, QACW, EPFTRB



Photo Shows a 4-Bolt Spherical Roller Bearing Flanged Cartridge Unit

Product Features

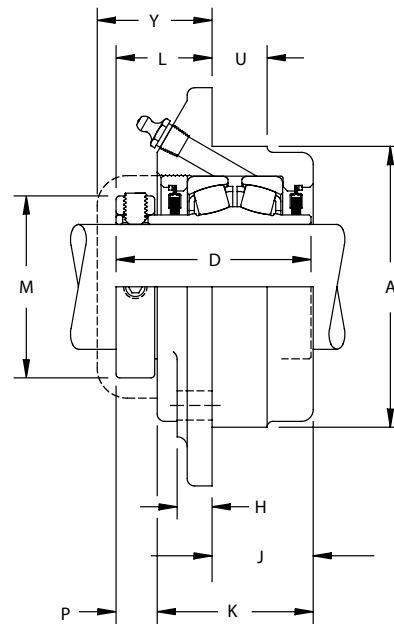
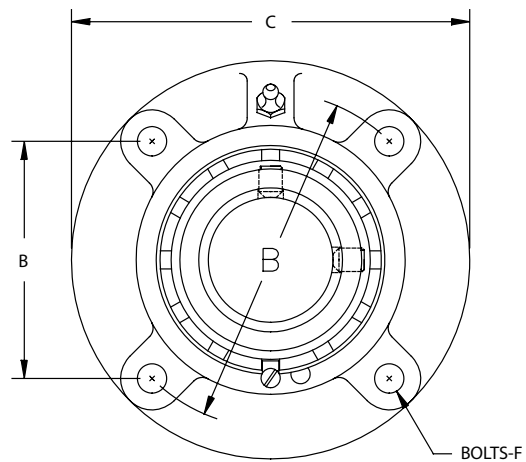
- Self aligning type E interchange
- Corrosion-resistant powder coating
- Cast iron housing
- Misalignment capabilities - total of 4°
- Broad range of sealing options
- Factory set clearance & lubrication
- Hardened spring locking collar
- Field interchangeable seals
- See Features and Benefits for additional info on pages 132 - 133.



Bearing Dimensions

Size Code	Shaft Diameter	Part Number	A Pilot Diameter	B Distance Between Bolt Holes		L Mounting Surface to Collar Face	C	D	F Bolts	H	J	K	M	P	U	Y	Approx. Weight																	
				Square	Circle																													
4-Bolt																																		
B416	1	FCB22416H	3.000	2 ⁹ / ₁₆	3 ⁵ / ₈	1 ⁹ / ₃₂	4 ³ / ₈	2 ⁹ / ₁₆	5 ¹ / ₁₆	7 ¹ / ₁₆	1 ¹ / ₄	2	1 ³ / ₄	17 ¹ / ₃₂	5 ⁵ / ₈	1 ⁵ / ₈	4.00																	
	25.00	FCB224M25H	76.200	65.10	92.08	32.50	111.10	65.09	8.00	11.10	31.80	50.80	44.40	13.50	15.90	41.30	1.60																	
B420	1 ³ / ₁₆	FCB22419H	3.375	2 ⁵⁹ / ₆₄	4 ¹ / ₈	1 ⁹ / ₃₂	5	2 ¹¹ / ₁₆	3 ³ / ₈	7 ¹ / ₁₆	1 ³ / ₈	2 ¹ / ₄	1 ³¹ / ₃₂	17 ¹ / ₃₂	3 ³ / ₄	1 ⁵ / ₈	5.00																	
	1 ¹ / ₄	FCB22420H																30.00	FCB224M30H	85.720	74.20	104.78	32.50	127.00	68.26	10.00	11.10	34.90	57.20	50.00	13.50	19.00	41.30	2.20
B424	1 ⁷ / ₁₆	FCB22423H	3.625	3 ³ / ₃₂	4 ³ / ₈	1 ¹⁵ / ₃₂	5 ¹ / ₄	2 ⁷ / ₈	3 ³ / ₈	1 ¹ / ₂	1 ³ / ₈	2 ³ / ₁₆	2 ⁵ / ₁₆	2 ¹ / ₃₂	3 ³ / ₄	1 ⁷ / ₈	6.00																	
	1 ¹ / ₂	FCB22424H																35.00	FCB224M35H	92.080	78.60	111.12	37.30	133.40	73.02	10.00	12.70	34.90	55.60	58.70	16.70	19.00	47.60	2.60
B428	1 ⁵ / ₈	FCB22426H	4.250	3 ⁵ / ₈	5 ¹ / ₈	1 ¹⁷ / ₃₂	6 ¹ / ₈	3 ¹ / ₈	7 ¹ / ₁₆	1 ¹ / ₂	1 ¹⁷ / ₃₂	2 ⁷ / ₁₆	2 ¹⁹ / ₃₂	2 ¹ / ₃₂	7 ¹ / ₈	1 ⁷ / ₈	9.00																	
	1 ¹¹ / ₁₆	FCB22427H																40.00	FCB224M40H	107.950	92.10	130.18	38.90	155.60	79.38	10.00	12.70	38.90	61.90	65.90	16.70	22.20	47.60	3.80
	1 ³ / ₄	FCB22428H																45.00	FCB224M45H	114.300	96.40	136.52	38.90	161.90	79.38	10.00	14.30	39.70	61.90	73.00	16.70	22.20	48.40	4.30
B432	1 ¹⁵ / ₁₆	FCB22431H	4.500	3 ⁵¹ / ₆₄	5 ³ / ₈	1 ¹⁷ / ₃₂	6 ³ / ₈	3 ¹ / ₈	7 ¹ / ₁₆	9 ¹ / ₁₆	1 ⁹ / ₁₆	2 ⁷ / ₁₆	2 ⁷ / ₈	2 ¹ / ₃₂	7 ¹ / ₈	1 ²⁹ / ₃₂	9.00																	
	2	FCB22432H																50.00	FCB224M50H	114.300	96.40	136.52	38.90	161.90	79.38	10.00	14.30	39.70	61.90	73.00	16.70	22.20	48.40	4.30
B436	2 ³ / ₁₆	FCB22435H	5.000	4 ¹ / ₄	6	1 ²¹ / ₃₂	7 ¹ / ₈	3 ⁵ / ₁₆	1 ¹ / ₂	9 ¹ / ₁₆	1 ⁹ / ₁₆	2 ¹ / ₂	3 ¹ / ₄	2 ⁵ / ₃₂	1	2 ¹ / ₃₂	12.00																	
	2 ¹ / ₄	FCB22436H																55.00	FCB224M55H	127.000	107.90	152.40	42.10	181.00	84.14	12.00	14.30	39.70	63.50	82.60	19.80	25.40	51.60	5.60
B440	2 ⁷ / ₁₆	FCB22439H	5.500	4 ¹⁹ / ₃₂	6 ¹ / ₂	1 ¹³ / ₁₆	7 ⁵ / ₈	3 ¹ / ₂	1 ¹ / ₂	5 ⁵ / ₈	1 ¹¹ / ₁₆	2 ⁵ / ₈	3 ⁹ / ₁₆	7 ¹ / ₈	1	2 ⁵ / ₃₂	16.00																	
	2 ¹ / ₂	FCB22440H																60.00	FCB224M60H	139.700	116.70	165.10	46.00	193.70	88.90	12.00	15.90	42.90	66.70	90.50	22.20	25.40	54.80	7.20
B448	2 ¹¹ / ₁₆	FCB22443H	6.375	5 ¹⁹ / ₆₄	7 ¹ / ₂	1 ³¹ / ₃₂	8 ³ / ₄	4	5 ⁵ / ₈	3 ³ / ₄	2	3 ¹ / ₈	4 ¹ / ₁₆	27 ¹ / ₃₂	1 ¹ / ₄	2 ⁵ / ₁₆	25.00																	
	2 ³ / ₄	FCB22444H																65.00	FCB224M65H	161.920	134.50	190.50	50.00	222.20	101.60	16.00	19.00	50.80	79.40	103.20	21.40	31.80	58.70	11.60
	2 ¹⁵ / ₁₆	FCB22447H																70.00	FCB224M70H	161.920	134.50	190.50	50.00	222.20	101.60	16.00	19.00	50.80	79.40	103.20	21.40	31.80	58.70	11.40
	3	FCB22448H																75.00	FCB224M75H	161.920	134.50	190.50	50.00	222.20	101.60	16.00	19.00	50.80	79.40	103.20	21.40	31.80	58.70	11.00
	65.00	FCB224M65H																161.920	134.50	190.50	50.00	222.20	101.60	16.00	19.00	50.80	79.40	103.20	21.40	31.80	58.70	11.60		
B456	3 ³ / ₁₆	FCB22451H	7.375	6 ³ / ₃₂	8 ⁵ / ₈	2 ⁷ / ₁₆	10 ¹ / ₄	4 ³ / ₈	3 ³ / ₄	1 ⁵ / ₁₆	2	3 ⁷ / ₁₆	4 ²⁹ / ₃₂	1 ⁵ / ₁₆	1 ¹ / ₄	2 ²⁵ / ₃₂	38.00																	
	3 ⁷ / ₁₆	FCB22455H																80.00	FCB224M80H	187.320	154.80	219.08	61.90	260.40	111.12	20.00	23.80	50.80	87.30	124.60	23.80	31.80	70.60	17.40
	3 ¹ / ₂	FCB22456H																85.00	FCB224M85H	187.320	154.80	219.08	61.90	260.40	111.12	20.00	23.80	50.80	87.30	124.60	23.80	31.80	70.60	16.90
	80.00	FCB224M80H																187.320	154.80	219.08	61.90	260.40	111.12	20.00	23.80	50.80	87.30	124.60	23.80	31.80	70.60	17.40		
	85.00	FCB224M85H																187.320	154.80	219.08	61.90	260.40	111.12	20.00	23.80	50.80	87.30	124.60	23.80	31.80	70.60	16.90		

Continued...



Continued...

Bearing Dimensions

Size Code	Shaft Diameter	Part Number	A Pilot Diameter	B Distance Between Bolt Holes		L Mounting Surface to Collar Face	C	D	F Bolts	H	J	K	M	P	U	Y	Approx. Weight
				Square	Circle												
4-Bolt (continued)																	
B464	3 11/16	FCB22459H	8.125	6 5/8	9 3/8	2 21/32	10 7/8	5 3/16	3/4	1 1/8	2 1/2	4 1/8	5 5/8	1 1/32	1 1/2	3 1/16	52.00
	3 15/16	FCB22463H															50.00
	4	FCB22464H															50.00
	90.00	FCB224M90H	206.380	168.30	238.12	67.50	276.20	131.76	20.00	28.60	63.50	104.80	142.90	26.20	38.10	77.80	24.60
	100.00	FCB224M100H															22.80

Additional Notes

Please call 1-866-REXNORD for availability
 Lubrication fitting tap size: for size code B416, 1/4 in-28 UNF; for all other size codes, 1/8 in PT
 Pilot Diameter tolerance, +.000 in/-.002 in (+0.00 mm/-0.05 mm)
 Bore tolerance for mounting, +.002 in/-.000 in (+0.05 mm/-0.00 mm)
 H labyrinth seals standard

All size codes available with type E lip seals, except E7 in size code B416
 For the Selection Guide, Load Ratings and Speed Limits, see the Link-Belt Spherical Roller Bearings Engineering section on pages 135 - 140.
 Note: Dimensions subject to change. Certified dimensions of ordered material furnished on request.

FCB22600

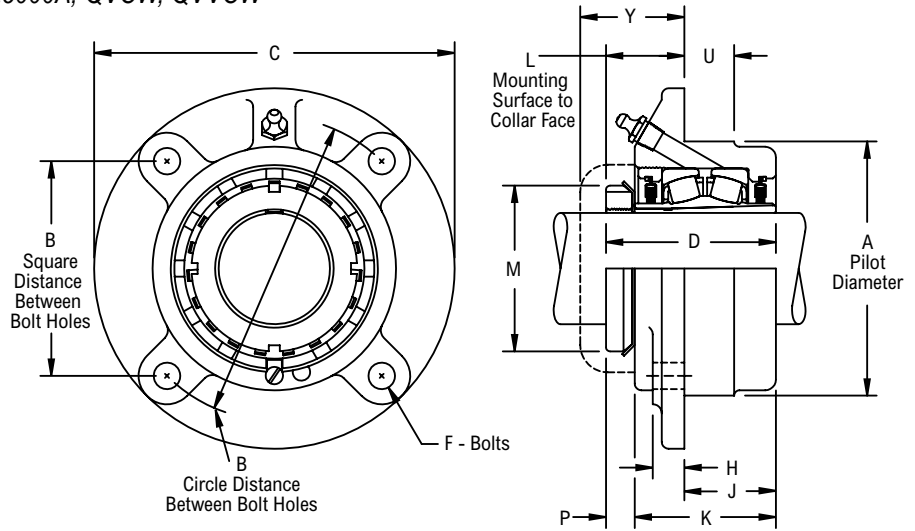
Interchange: FCIP, USFC5000A, USFCE5000A, QVCW, QVVCW



Photo Shows a 4-Bolt Spherical Roller Bearing Flanged Cartridge Unit

Product Features

- Self aligning type E interchange
- Corrosion-resistant powder coating
- Cast iron housing
- Misalignment capabilities - total of 4°
- Broad range of sealing options
- Factory set clearance & lubrication
- Enhanced life mounting style
- Field interchangeable seals
- See Features and Benefits for additional info on pages 132 - 133.



Bearing Dimensions

Size Code	Shaft Diameter	Part Number	A Pilot Diameter	B Distance Between Bolt Holes		L Mounting Surface to Collar Face	C	D	F Bolts	H	J	K	M	P	U	Y	Approx. Weight
				Square	Circle												
4-Bolt																	
B624	1 7/16	FCB22623H	3.625	3 3/32	4 3/8	1 17/64	5 1/4	2.71	3/8	1/2	1 3/8	2 3/16	2 1/4	29/64	3/4	1 7/8	6.00
B631	1 15/16	FCB22631H	4.500	3 51/64	5 3/8	1 31/64	6 3/8	3.08	7/16	9/16	1 9/16	2 7/16	2 31/32	39/64	7/8	1 29/32	9.00
B635	2 3/16	FCB22635H	5.000	4 1/4	6	1 1/2	7 1/8	3.16	1/2	9/16	1 9/16	2 1/2	3 5/32	5/8	1	2 1/32	12.00
B639	2 7/16	FCB22639H	5.500	4 19/32	6 1/2	1 19/32	7 5/8	3.28	1/2	5/8	1 11/16	2 5/8	3 5/8	41/64	1	2 5/32	16.00
B647	2 11/16	FCB22643H	6.375	5 19/64	7 1/2	1 53/64	8 3/4	3.86	5/8	3/4	2	3 1/8	4 5/32	45/64	1 1/4	2 5/16	25.00
	2 15/16	FCB22647H															24.00
B655	3 7/16	FCB22655H	7.375	6 3/32	8 5/8	2 25/64	10 1/4	4.29	3/4	15/16	2	3 7/16	4 15/16	57/64	1 1/4	2 25/32	37.00
B663	3 15/16	FCB22663H	8.125	6 5/8	9 3/8	2 17/32	10 7/8	4.94	3/4	1 1/8	2 1/2	4 1/8	5 7/16	59/64	2	3 1/16	50.00

Additional Notes

- Please call 1-866-REXNORD for availability
- Lubrication fitting tap size, 1/8 in PT
- Dimensions for "D", "L" & "P" based on unmounted condition
- Pilot Diameter tolerance, +.000 in/- .002 in (+0.00 mm/-0.05 mm)
- Bore tolerance for mounting, +.002 in/- .000 in (+0.05 mm/-0.00 mm)
- H labyrinth seals standard

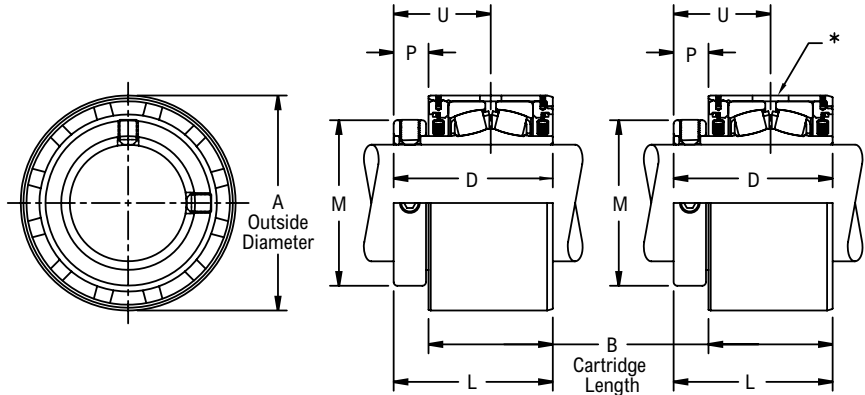
All size codes available with type E lip seals & E7 triple lip seals
 For the Selection Guide, Load Ratings and Speed Limits, see the Link-Belt Spherical Roller Bearings Engineering section on pages 135 - 140.
 Note: Dimensions subject to change. Certified dimensions of ordered material furnished on request.



Photo Shows a Spherical Roller Bearing Cartridge Unit with Steel Housing

Product Features

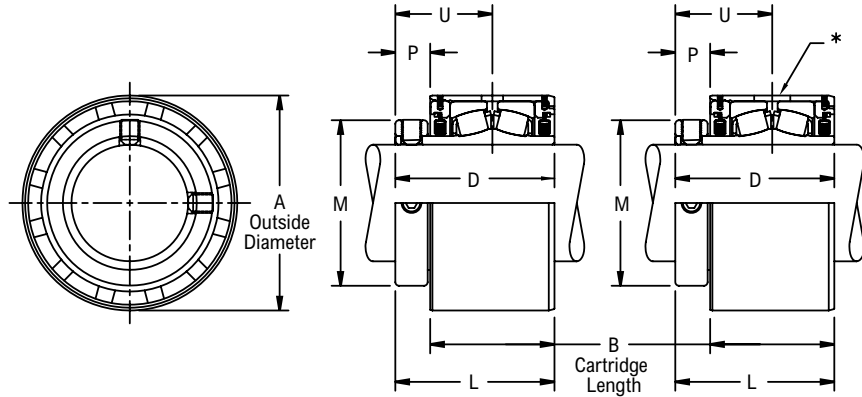
- Steel housing
- Misalignment capabilities - total of 4°
- Broad range of sealing options
- Factory set clearance & lubrication
- Hardened spring locking collar
- Field interchangeable seals
- See Features and Benefits for additional info on pages 132 - 133.



Bearing Dimensions

Size Code	Shaft Diameter	Part Number	A Outside Diameter	B Cartridge Length	D	L	M	P	U	Approx. Weight								
B416	1	CSEB22416H	2.6650	2	2 ⁹ / ₁₆	2 ⁹ / ₁₆	1 ³ / ₄	⁹ / ₁₆	1 ⁹ / ₁₆	3.00								
	25.00	CSEB224M25H	67.6900	50.800	65.09	65.10	44.40	14.30	39.70	1.30								
B420	1 ³ / ₁₆	CSEB22419H	2.9150	2 ¹ / ₈	2 ¹¹ / ₁₆	2 ¹¹ / ₁₆	1 ³¹ / ₃₂	⁹ / ₁₆	1 ⁵ / ₈	4.00								
	1 ¹ / ₄	CSEB22420H																
B424	30.00	CSEB224M30H	74.0400	53.980	68.26	68.30	50.00	14.30	41.30	1.70								
	1 ⁷ / ₁₆	CSEB22423H	3.1240	2 ³ / ₁₆	2 ⁷ / ₈	2 ⁷ / ₈	2 ⁵ / ₁₆	¹¹ / ₁₆	1 ²⁵ / ₃₂	4.00								
1 ¹ / ₂	CSEB22424H																	
B428	35.00	CSEB224M35H	79.3500	55.560	73.02	73.00	58.70	17.50	45.20	1.80								
	1 ⁵ / ₈	CSEB22426H	3.6360	2 ⁷ / ₁₆	3 ¹ / ₈	3 ¹ / ₈	2 ¹⁹ / ₃₂	¹¹ / ₁₆	1 ²⁹ / ₃₂	6.00								
	1 ¹¹ / ₁₆	CSEB22427H								5.00								
	1 ³ / ₄	CSEB22428H								2.50								
40.00	CSEB224M40H	92.3500								61.910	79.38	79.40	65.90	17.50	48.40	2.50		
B432	1 ¹⁵ / ₁₆	CSEB22431H	3.8330	2 ²⁵ / ₆₄	3 ¹ / ₈	3 ¹ / ₈	2 ⁷ / ₈	²³ / ₃₂	1 ²⁹ / ₃₂	6.00								
	2	CSEB22432H								5.00								
	45.00	CSEB224M45H								97.3600	60.720	79.38	79.40	73.00	18.30	48.40	2.60	
	50.00	CSEB224M50H															2.30	
B436	2 ³ / ₁₆	CSEB22435H	4.2270	2 ¹ / ₂	3 ⁵ / ₁₆	3 ⁵ / ₁₆	3 ¹ / ₄	¹³ / ₁₆	2 ¹ / ₁₆	7.00								
	2 ¹ / ₄	CSEB22436H																
B440	55.00	CSEB224M55H	107.3600	63.500	84.14	84.10	82.60	20.60	52.40	3.20								
	2 ¹ / ₄	CSEB224B36H	4.6210	2 ⁵ / ₈	3 ¹ / ₂	3 ¹ / ₂	3 ⁹ / ₁₆	⁷ / ₈	2 ³ / ₁₆	8.00								
2 ⁷ / ₁₆	CSEB22439H																	
B448	2 ¹ / ₂	CSEB22440H	117.3700	66.680	88.90	88.90	90.50	22.20	55.60	3.90								
	60.00	CSEB224M60H																
	2 ¹¹ / ₁₆	CSEB22443H									5.4070	3 ¹ / ₈	4	4	4 ¹ / ₁₆	⁷ / ₈	2 ⁷ / ₁₆	14.00
	2 ³ / ₄	CSEB22444H																
	2 ¹⁵ / ₁₆	CSEB22447H									3	3 ¹ / ₈	4	4	4 ¹ / ₁₆	⁷ / ₈	2 ⁷ / ₁₆	13.00
	3	CSEB22448H																
	65.00	CSEB224M65H																6.60
70.00	CSEB224M70H	137.2616	79.380	101.60	101.60	103.20	22.20	61.90	6.40									
75.00	CSEB224M75H								5.90									
B456	3 ³ / ₁₆	CSEB22451H	6.1940	3 ⁷ / ₁₆	4 ³ / ₈	4 ³ / ₈	4 ²⁹ / ₃₂	¹⁵ / ₁₆	2 ²¹ / ₃₂	20.00								
	3 ⁷ / ₁₆	CSEB22455H																
	3 ¹ / ₂	CSEB22456H								18.00								
	80.00	CSEB224M80H								157.3300	87.310	111.12	111.10	124.60	23.80	67.50	9.00	

Continued...



Continued...

Bearing Dimensions

Size Code	Shaft Diameter	Part Number	A Outside Diameter	B Cartridge Length	D	L	M	P	U	Approx. Weight
B456	85.00	CSEB224M85H	157.3300	87.310	111.12	111.10	124.60	23.80	67.50	8.60
B464	3 11/16	CSEB22459H	7.3750	4	5 1/16	5 1/16	5 5/8	1 1/16	3 1/16	33.00
	3 15/16	CSEB22463H								31.00
	4	CSEB22464H								15.90
	90.00	CSEB224M90H	187.3200	101.600	128.59	128.60	142.90	27.00	77.80	14.10
	100.00	CSEB224M100H								

Additional Notes

Please call 1-866-REXNORD for availability
 O.D. tolerance, +.000 in/-.002 in (+0.00 mm/-0.05 mm)
 Bore tolerance for mounting, +.002 in/-.000 in (+0.05 mm/-0.00 mm)
 Expansion - is 3/8 in for all size codes
 *Expansion plug diameter .531 in (13.49 mm), engagement depth .125 in +/- .015 in (3.18 mm +/- 0.38 mm)
 Hole for fixed location & slot for expansion location in the same housing

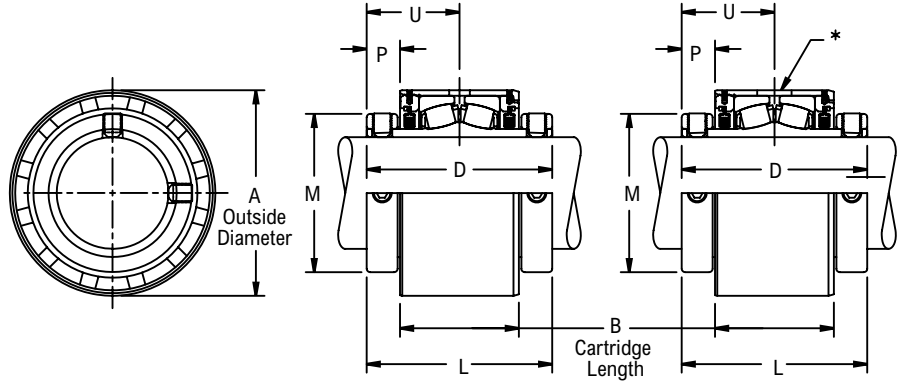
H labyrinth seals standard
 All size codes available with type E lip seals, except E7 in size code B416
 For the Selection Guide, Load Ratings and Speed Limits, see the Link-Belt Spherical Roller Bearings Engineering section on pages 135 - 140.
 Note: Dimensions subject to change. Certified dimensions of ordered material furnished on request.



Photo Shows a Spherical Roller Bearing Cartridge Unit with Steel Housing

Product Features

- Steel housing
- Misalignment capabilities - total of 4°
- Broad range of sealing options
- Factory set clearance & lubrication
- Two hardened spring locking collars
- Field interchangeable seals
- See Features and Benefits for additional info on pages 132 - 133.



Bearing Dimensions

Size Code	Shaft Diameter	Part Number	A Outside Diameter	B Cartridge Length	D	L	M	P	U	Approx. Weight
B524	1 7/16	CSEB22523H	3.1240	2 3/16	3 9/16	3 9/16	2 5/16	11/16	1 25/32	4.20
B528	1 11/16	CSEB22527H	3.6360	2 7/16	3 13/16	3 13/16	2 19/32	11/16	1 29/32	5.60
B531	1 15/16	CSEB22531H	3.8330	2 25/64	3 13/16	3 13/16	2 7/8	11/16	1 29/32	6.10
B536	2	CSEB22532H	4.2270	2 1/2	4 1/8	4 1/8	3 1/4	13/16	2 1/16	9.00
	2 3/16	CSEB22535H								
B540	2 7/16	CSEB22539H	4.6210	2 5/8	4 3/8	4 3/8	3 9/16	7/8	2 3/16	10.10
B548	2 11/16	CSEB22543H	5.4070	3 1/8	4 7/8	4 7/8	4 1/16	7/8	2 7/16	16.40
	2 15/16	CSEB22547H								15.30
B556	3 7/16	CSEB22555H	6.1940	3 7/16	5 5/16	5 5/16	4 29/32	15/16	2 21/32	21.10
B564	3 15/16	CSEB22563H	7.3750	4	6 1/8	6 1/8	5 5/8	1 1/16	3 1/16	36.10
	4	CSEB22564H								35.60
B572	4 3/16	CSEB22567YH	7.9670	4 1/4	6 1/4	6 1/4	6 3/16	1	3 1/8	52.80
	4 7/16	CSEB22571YH								50.60
	4 1/2	CSEB22572YH								49.90
	110.00	CSEB225M110YH								22.80
	115.00	CSEB225M115YH								22.50
B580	4 15/16	CSEB22579YH	9.3427	5 9/16	7 7/8	7 7/8	7 1/16	1 5/32	3 15/16	55.30
	5	CSEB22580YH								54.70
	125.00	CSEB225M125YH								24.60

Additional Notes

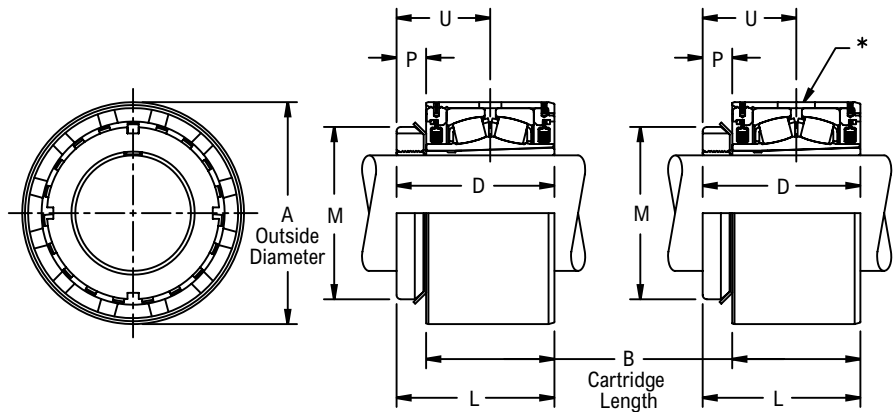
- Please call 1-866-REXNORD for availability
- O.D. tolerance, for size codes B564 and smaller +.000 in/-.002 in (+0.00 mm/-0.05 mm); for all other size codes +.000 in/-.003 in (+0.00 mm/-0.08 mm)
- Bore tolerance for mounting, +.002 in/-.000 in (+0.05 mm/-0.00 mm)
- Expansion - is 3/8 in for all size codes
- *Expansion plug diameter .531 in (13.49 mm), engagement depth .125 in +/- .015 in (3.18 mm +/- 0.38 mm)

- Hole for fixed location & slot for expansion location in the same housing
- H labyrinth seals standard
- All size codes available with type E lip seals & E7 triple lip seals
- For the Selection Guide, Load Ratings and Speed Limits, see the Link-Belt Spherical Roller Bearings Engineering section on pages 135 - 140.
- Note: Dimensions subject to change. Certified dimensions of ordered material furnished on request.

CSEB22600



Photo Shows a Spherical Roller Bearing Cartridge Unit with Steel Housing



Product Features

- Steel housing
- Misalignment capabilities - total of 4°
- Broad range of sealing options
- Factory set clearance & lubrication
- Enhanced life mounting style
- Field interchangeable seals
- See Features and Benefits for additional info on pages 132 - 133.

Bearing Dimensions

Size Code	Shaft Diameter	Part Number	A Outside Diameter	B Cartridge Length	D	L	M	P	U	Approx. Weight
B624	1 7/16	CSEB22623H	3.1240	2 3/16	2.71	2 3/4	2 1/4	1/2	1 39/64	4.00
B631	1 15/16	CSEB22631H	3.8330	2 29/64	3.08	3 1/16	2 31/32	39/64	1 55/64	5.00
B635	2 3/16	CSEB22635H	4.2270	2 1/2	3.16	3 5/32	3 5/32	5/8	1 29/32	7.00
B639	2 7/16	CSEB22639H	4.6210	2 5/8	3.28	3 19/64	3 5/8	45/64	1 31/32	8.00
B647	2 11/16	CSEB22643H	5.4070	3 1/8	3.86	3 7/8	4 5/32	55/64	2 19/64	14.00
	2 15/16	CSEB22647H								13.00
B655	3 7/16	CSEB22655H	6.1940	3 7/16	4.29	4 5/16	4 15/16	7/8	2 37/64	18.00
B663	3 15/16	CSEB22663H	7.3750	4	4.94	4 15/16	5 7/16	15/16	2 15/16	31.00

Additional Notes

- Please call 1-866-REXNORD for availability
- O.D. tolerance, +.000 in/-.002 in (+0.00 mm/-0.05 mm)
- Bore tolerance for mounting, +.002 in/-.000 in (+0.05 mm/-0.00 mm)
- Expansion - is 3/8 in for all size codes
- *Expansion plug diameter .531 in (13.49 mm), engagement depth .125 in +/- .015 in (3.18 mm +/- 0.38 mm)
- Hole for fixed location & slot for expansion location in the same housing

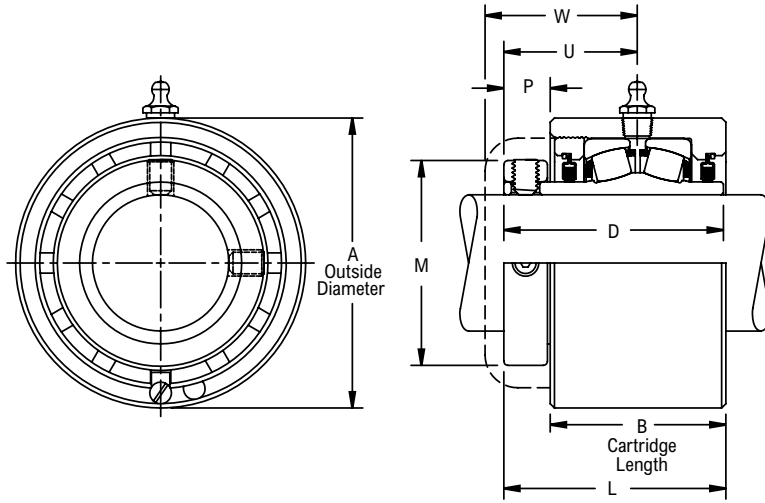
- Dimensions for "D", "P" & "U" based on unmounted condition
- H labyrinth seals standard
- All size codes available with type E lip seals & E7 triple lip seals
- For the Selection Guide, Load Ratings and Speed Limits, see the Link-Belt Spherical Roller Bearings Engineering section on pages 135 - 140.
- Note: Dimensions subject to change. Certified dimensions of ordered material furnished on request.



Photo Shows a Spherical Roller Bearing Cartridge Unit with Cast Iron Housing

Product Features

- Corrosion resistant powder coating
- Cast iron housing
- Misalignment capabilities - total of 4°
- Broad range of sealing options
- Factory set clearance & lubrication
- Hardened spring locking collar
- Field interchangeable seals
- See Features and Benefits for additional info on pages 132 - 133.



Bearing Dimensions

Size Code	Shaft Diameter	Part Number	A Outside Diameter	B Cartridge Length	D	L	M	P	U	W	Approx. Weight
B416	1	CB22416H	3.0000	2	2 ⁹ / ₁₆	2 ¹⁹ / ₃₂	1 ³ / ₄	¹⁷ / ₃₂	1 ⁹ / ₁₆	1 ²⁹ / ₃₂	3.00
	25.00	CB224M25H	76.2000	50.800	65.09	65.90	44.40	13.50	39.70	48.40	1.40
B420	1 ³ / ₁₆	CB22419H	3.2190	2 ¹ / ₈	2 ¹¹ / ₁₆	2 ²³ / ₃₂	1 ³¹ / ₃₂	¹⁷ / ₃₂	1 ⁵ / ₈	1 ³¹ / ₃₂	4.00
	1 ¹ / ₄	CB22420H									
B424	30.00	CB224M30H	81.7600	53.980	68.26	69.00	50.00	13.50	41.30	50.00	1.70
	1 ⁷ / ₁₆	CB22423H	3.4370	2 ³ / ₁₆	2 ⁷ / ₈	2 ²⁹ / ₃₂	2 ⁵ / ₁₆	²¹ / ₃₂	1 ²⁵ / ₃₂	2 ³ / ₁₆	4.00
1 ¹ / ₂	CB22424H										
B428	35.00	CB224M35H	87.3000	55.560	73.02	73.80	58.70	16.70	45.20	55.60	2.10
	1 ⁵ / ₈	CB22426H	3.9370	2 ⁷ / ₁₆	3 ¹ / ₈	3 ⁵ / ₃₂	2 ¹⁹ / ₃₂	²¹ / ₃₂	1 ²⁹ / ₃₂	2 ¹ / ₄	6.00
1 ¹¹ / ₁₆	CB22427H										
1 ³ / ₄	CB22428H										
B432	40.00	CB224M40H	100.0000	61.910	79.38	80.20	65.90	16.70	48.40	57.20	2.90
	1 ¹⁵ / ₁₆	CB22431H	4.1250	2 ⁷ / ₁₆	3 ¹ / ₈	3 ⁵ / ₃₂	2 ⁷ / ₈	²¹ / ₃₂	1 ²⁹ / ₃₂	2 ⁹ / ₃₂	6.00
2	CB22432H										
45.00	CB224M45H										
B436	50.00	CB224M50H	104.7800	61.910	79.38	80.20	73.00	16.70	48.40	57.90	3.10
	2 ³ / ₁₆	CB22435H	4.5310	2 ⁹ / ₁₆	3 ⁵ / ₁₆	3 ¹¹ / ₃₂	3 ¹ / ₄	²⁵ / ₃₂	2 ¹ / ₁₆	2 ⁷ / ₁₆	8.00
2 ¹ / ₄	CB22436H										
55.00	CB224M55H										
B440	60.00	CB224M60H	115.0900	65.090	84.14	84.90	82.60	19.80	52.40	61.90	3.80
	2 ⁷ / ₁₆	CB22439H	5.0000	2 ⁵ / ₈	3 ¹ / ₂	3 ¹⁷ / ₃₂	3 ⁹ / ₁₆	²¹ / ₃₂	2 ³ / ₁₆	2 ⁹ / ₁₆	10.00
2 ¹ / ₂	CB22440H										
60.00	CB224M60H										
B448	2 ¹¹ / ₁₆	CB22443H	5.8750	3 ¹ / ₈	4	4 ¹ / ₃₂	4 ¹ / ₁₆	²⁷ / ₃₂	2 ⁷ / ₁₆	2 ²⁵ / ₃₂	18.00
	2 ³ / ₄	CB22444H									17.00
B456	2 ¹⁵ / ₁₆	CB22447H	149.2200	79.380	101.60	102.40	103.20	21.40	61.90	70.60	16.00
	3	CB22448H									8.10
B456	65.00	CB224M65H	171.4500	87.310	111.12	111.10	124.60	23.80	67.50	76.20	8.00
	70.00	CB224M70H									7.80
B456	75.00	CB224M75H	6.7500	3 ⁷ / ₁₆	4 ³ / ₈	4 ³ / ₈	4 ²⁹ / ₃₂	¹⁵ / ₁₆	2 ²¹ / ₃₂	3	25.00
	3 ³ / ₁₆	CB22451H									23.00
B456	3 ⁷ / ₁₆	CB22455H	171.4500	87.310	111.12	111.10	124.60	23.80	67.50	76.20	11.20
	3 ¹ / ₂	CB22456H									11.00
B456	80.00	CB224M80H	171.4500	87.310	111.12	111.10	124.60	23.80	67.50	76.20	11.20
	85.00	CB224M85H									11.00

Additional Notes

- Please call 1-866-REXNORD for availability
- Lubrication fitting tap size, 1/8 in PT
- O.D. tolerance, +.000 in/-.002 in (+0.00 mm/-0.05 mm)
- Bore tolerance for mounting, +.002 in/-.000 in (+0.05 mm/-0.00 mm)
- H labyrinth seals standard
- All size codes available with type E lip seals, except E7 in size code B416

For the Selection Guide, Load Ratings and Speed Limits, see the Link-Belt Spherical Roller Bearings Engineering section on pages 135 - 140.
 Note: Dimensions subject to change. Certified dimensions of ordered material furnished on request.

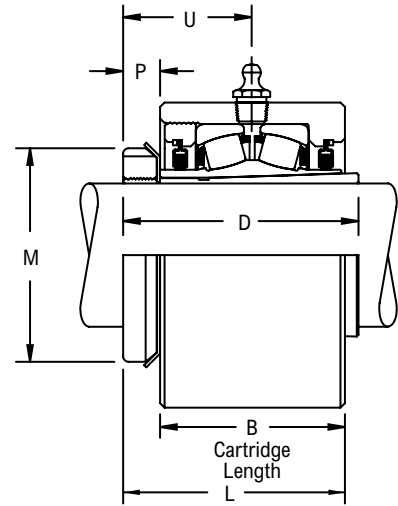
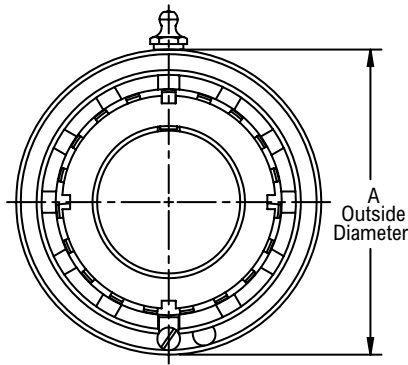
CB22600



Photo Shows a Spherical Roller Bearing Cartridge Unit with Cast Iron Housing

Product Features

- Corrosion resistant powder coating
 - Cast iron housing
 - Misalignment capabilities - total of 4°
 - Broad range of sealing options
 - Factory set clearance & lubrication
 - Enhanced life mounting style
 - Field interchangeable seals
- See Features and Benefits for additional info on pages 132 - 133.



Bearing Dimensions

Size Code	Shaft Diameter	Part Number	A Outside Diameter	B Cartridge Length	D	L	M	P	U	Approx. Weight
B624	1 7/16	CB22623H	3.4370	2 3/16	2.71	2 13/16	2 1/4	9/16	1 43/64	4.00
B631	1 15/16	CB22631H	4.1250	2 7/16	3.08	3 11/64	2 31/32	43/64	1 55/64	6.00
B635	2 3/16	CB22635H	4.5310	2 9/16	3.16	3 7/32	3 5/32	21/32	1 29/32	8.00
B639	2 7/16	CB22639H	5.0000	2 5/8	3.28	3 25/64	3 5/8	43/64	2 3/64	10.00
B647	2 11/16	CB22643H	5.8750	3 1/8	3.86	4	4 5/32	3/4	2 19/64	18.00
	2 15/16	CB22647H								16.00
B655	3 7/16	CB22655H	6.7500	3 7/16	4.29	4 3/8	4 15/16	7/8	2 9/16	23.00

Additional Notes

- Please call 1-866-REXNORD for availability
- Lubrication fitting tap size, 1/8 in PT
- Dimensions for "D", "P" & "U" based on unmounted condition
- O.D. tolerance, +.000 in/- .002 in (+0.00 mm/-0.05 mm)
- Bore tolerance for mounting, +.002 in/- .000 in (+0.05 mm/-0.00 mm)
- H labyrinth seals standard

All size codes available with type E lip seals & E7 triple lip seals
 For the Selection Guide, Load Ratings and Speed Limits, see the Link-Belt Spherical Roller Bearings Engineering section on pages 135 - 140.

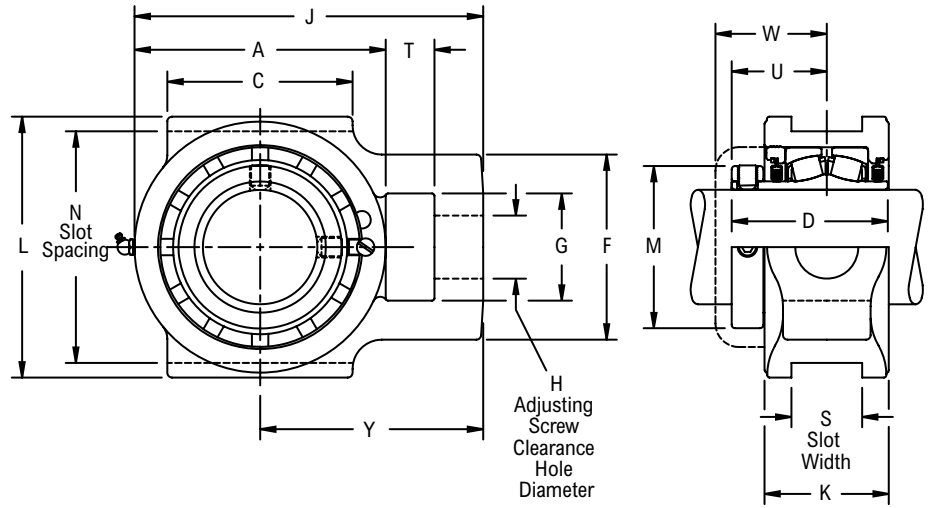
Note: Dimensions subject to change. Certified dimensions of ordered material furnished on request.

TB22400

Interchange: WSTUS2, WSTUE, TBR, USTU5000, QATU, ETUTRB



Photo Shows a Spherical Roller Bearing Take-up Unit



Product Features

- Corrosion-resistant powder coating
- Cast iron housing
- Misalignment capabilities - total of 4°
- Broad range of sealing options
- Factory set clearance & lubrication
- Hardened spring locking collar
- Field interchangeable seals
- See Features and Benefits for additional info on pages 132 - 133.

Bearing Dimensions

Size Code	Shaft Diameter	Part Number	H Adjusting Screw Hole Diameter	N Slot Spacing	S Slot Width	A	C	D	F	G	J	K	L	M	T	U	W	Y	Approx. Weight
B416	1	TB22416H	3/4	3.000	0.531	3	2 1/4	2 9/16	2	1 1/4	4 1/16	2	3 5/8	1 3/4	5/8	1 9/16	1 29/32	2 9/16	4.40
	25.00	TB224M25H	19.10	76.200	13.490	76.20	57.20	65.09	50.80	31.80	103.20	50.80	92.10	44.40	15.90	39.70	48.40	65.10	2.00
B420	1 3/16	TB22419H	7/8	3.500	0.531	3 3/8	2 1/2	2 11/16	2 5/16	1 7/16	4 9/16	2 1/8	4 1/8	1 31/32	5/8	1 5/8	1 31/32	2 7/8	5.70
	1 1/4	TB22420H	30.00	88.900	13.490	85.73	63.50	68.26	58.70	36.50	115.90	53.90	104.80	50.00	15.90	41.30	50.00	73.00	2.60
B424	1 7/16	TB22423H	7/8	3.500	0.531	3 3/4	2 3/4	2 7/8	2 3/8	1 7/16	5 1/16	2 3/16	4 1/8	2 5/16	5/8	1 25/32	2 3/16	3 1/4	6.40
	1 1/2	TB22424H	35.00	88.900	13.490	95.25	69.80	73.02	60.30	36.50	128.60	55.60	104.80	58.70	15.90	45.20	55.60	82.60	2.90
B428	1 5/8	TB22426H	1 1/8	4.000	0.687	4 1/4	3 1/4	3 1/8	3 3/16	1 15/16	5 15/16	2 7/16	4 3/4	2 19/32	3/4	1 29/32	2 1/4	3 13/16	9.70
	1 7/16	TB22423H	40.00	101.600	17.460	107.95	82.60	79.38	81.00	49.20	150.80	61.90	120.60	65.90	19.00	48.40	57.20	96.80	4.50
B432	1 3/4	TB22428H	1 1/8	4.000	0.687	4 1/2	3 3/8	3 1/8	3 3/16	1 15/16	6 3/16	2 7/16	4 1/2	2 7/8	3/4	1 29/32	2 9/32	3 15/16	9.90
	1 15/16	TB22431H	2	101.600	17.460	114.30	85.70	79.38	81.00	49.20	157.20	61.90	114.30	73.00	19.00	48.40	57.90	100.00	4.70
B436	2	TB22432H	1 3/8	4.500	0.813	5	3 3/4	3 5/16	3 3/4	2 1/4	7 1/8	2 1/2	5 1/4	3 1/4	1 1/4	2 1/16	2 7/16	4 5/8	14.10
	2 1/4	TB22436H	34.90	114.300	20.640	127.00	95.20	84.14	95.20	57.20	181.00	63.50	133.40	82.60	31.80	52.40	61.90	117.50	6.80
B440	2 3/16	TB22435H	1 3/8	5.125	1.063	5 1/2	4	3 1/2	4 1/8	2 1/4	7 13/16	2 5/8	5 7/8	3 9/16	1 1/4	2 3/16	2 9/16	5 1/16	18.00
	2 1/2	TB22440H	60.00	130.180	26.990	139.70	101.60	88.90	104.80	57.20	198.40	66.70	149.20	90.50	31.80	55.60	65.10	128.60	8.30
B448	2 7/16	TB22439H	1 3/8	5.937	1.812	6 7/16	4 3/4	4	4 3/4	2 3/4	9 1/8	3 1/8	6 11/16	4 1/16	1 1/2	2 7/16	2 25/32	5 15/16	23.60
	2 11/16	TB22443H	70.00	150.810	46.020	163.50	120.60	101.60	120.60	69.80	231.80	79.40	169.90	103.20	38.10	61.90	70.60	150.80	23.50
	2 3/4	TB22444H	75.00	150.810	46.020	163.50	120.60	101.60	120.60	69.80	231.80	79.40	169.90	103.20	38.10	61.90	70.60	150.80	23.00
	2 15/16	TB22447H	3	150.810	46.020	163.50	120.60	101.60	120.60	69.80	231.80	79.40	169.90	103.20	38.10	61.90	70.60	150.80	22.90
	3	TB22448H	65.00	150.810	46.020	163.50	120.60	101.60	120.60	69.80	231.80	79.40	169.90	103.20	38.10	61.90	70.60	150.80	10.60
B456	3 1/16	TB22455H	1 7/8	6.812	1.812	7 3/8	5 1/2	4 3/8	4 7/8	2 7/8	10	3 7/16	7 13/16	4 29/32	1 5/8	2 21/32	3	6 5/16	43.50
	3 1/2	TB22456H	80.00	173.020	46.020	187.30	139.70	111.12	123.80	73.00	254.00	87.30	198.40	124.60	41.30	67.50	76.20	160.30	43.10
	3 7/16	TB22455H	85.00	173.020	46.020	187.30	139.70	111.12	123.80	73.00	254.00	87.30	198.40	124.60	41.30	67.50	76.20	160.30	20.50
B464	3 15/16	TB22463H	2 1/8	8.625	2.062	8 7/8	7	5 1/16	5 1/4	3 1/8	12 1/8	4 1/8	9 7/16	5 5/8	2 1/8	3 1/16	3 7/16	7 11/16	77.00
	4	TB22464H	90.00	219.080	52.370	225.40	177.80	128.59	133.40	79.40	308.00	104.80	239.70	142.90	54.00	77.80	87.30	195.30	76.00
	90.00	TB224M90H	53.98	219.080	52.370	225.40	177.80	128.59	133.40	79.40	308.00	104.80	239.70	142.90	54.00	77.80	87.30	195.30	34.90
	100.00	TB224M100H	53.98	219.080	52.370	225.40	177.80	128.59	133.40	79.40	308.00	104.80	239.70	142.90	54.00	77.80	87.30	195.30	34.50

Additional Notes

- Please call 1-866-REXNORD for availability
- Lubrication fitting tap size, 1/8" PT
- Take-up slot spacing & width tolerance, +.005 in/-0.015 in (+0.13 mm/-0.38 mm)
- H labyrinth seals standard
- All size codes available with type E lip seals, except E7 in size code B416

For the Selection Guide, Load Ratings and Speed Limits, see the Link-Belt Spherical Roller Bearings Engineering section on pages 135 - 140.

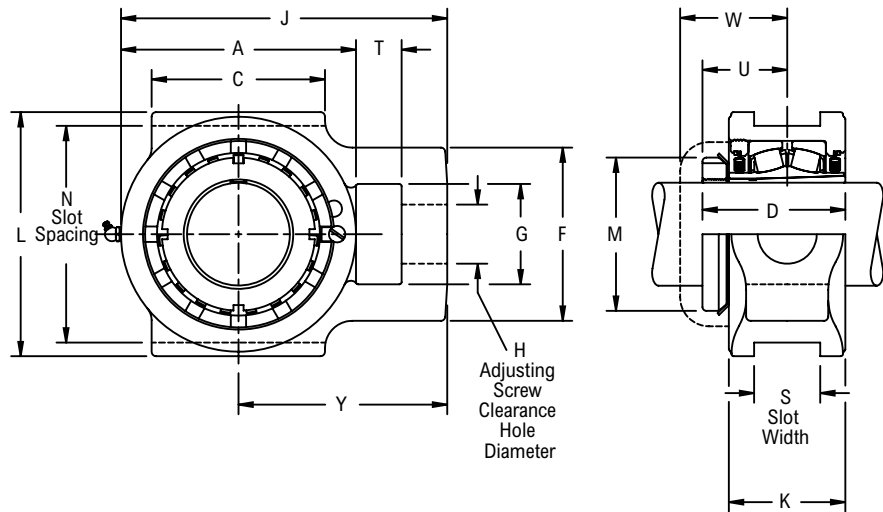
Note: Dimensions subject to change. Certified dimensions of ordered material furnished on request.

TB22600**Interchange:** WSTUIP, USTU5000A, QVVTU

Photo Shows a Spherical Roller Bearing Take-up Unit

Product Features

- Corrosion-resistant powder coating
 - Cast iron housing
 - Misalignment capabilities - total of 4°
 - Broad range of sealing options
 - Factory set clearance & lubrication
 - Enhanced life mounting style
 - Field interchangeable seals
- See Features and Benefits for additional info on pages 132 - 133.

**Bearing Dimensions**

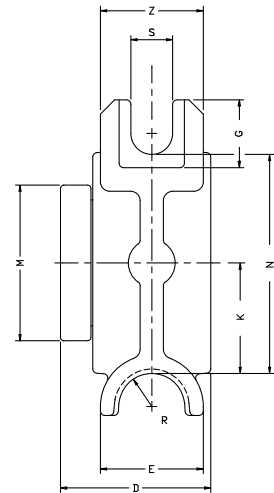
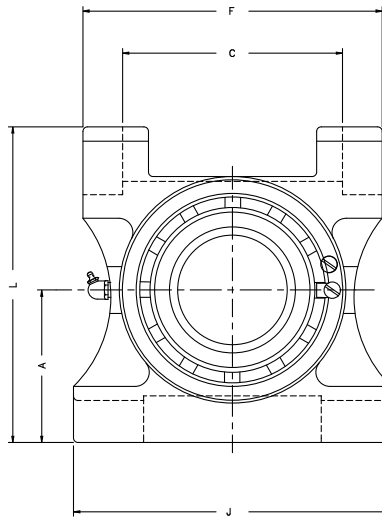
Size Code	Shaft Diameter	Part Number	H Adjusting Screw Hole Diameter	N Slot Spacing	S Slot Width	A	C	D	F	G	J	K	L	M	T	U	W	Y	Approx. Weight
B624	1 ⁷ / ₁₆	TB22623H	⁷ / ₈	3.500	0.531	3 ³ / ₄	2 ³ / ₄	2.71	2 ³ / ₈	1 ⁷ / ₁₆	5 ¹ / ₁₆	2 ³ / ₁₆	4 ¹ / ₈	2 ¹ / ₄	⁵ / ₈	1 ³⁹ / ₆₄	2 ³ / ₁₆	3 ¹ / ₄	6.40
B631	1 ¹⁵ / ₁₆	TB22631H	1 ¹ / ₈	4.000	0.687	4 ¹ / ₂	3 ³ / ₈	3.08	3 ³ / ₁₆	1 ¹⁵ / ₁₆	6 ³ / ₁₆	2 ⁷ / ₁₆	4 ¹ / ₂	2 ³¹ / ₃₂	³ / ₄	1 ⁵⁵ / ₆₄	2 ⁹ / ₃₂	3 ¹⁵ / ₁₆	9.70
B635	2 ³ / ₁₆	TB22635H	1 ³ / ₈	4.500	0.813	5	3 ³ / ₄	3.16	3 ³ / ₄	2 ¹ / ₄	7 ¹ / ₈	2 ¹ / ₂	5 ¹ / ₄	3 ⁵ / ₃₂	1 ¹ / ₄	1 ²⁹ / ₃₂	2 ⁷ / ₁₆	4 ⁵ / ₈	14.10
B639	2 ⁷ / ₁₆	TB22639H	1 ³ / ₈	5.125	1.063	5 ¹ / ₂	4	3.28	4 ¹ / ₈	2 ¹ / ₄	7 ¹³ / ₁₆	2 ⁵ / ₈	5 ⁷ / ₈	3 ⁵ / ₈	1 ¹ / ₄	1 ³¹ / ₃₂	2 ⁹ / ₁₆	5 ¹ / ₁₆	17.80
B647	2 ¹¹ / ₁₆	TB22643H	1 ⁵ / ₈	5.937	1.812	6 ⁷ / ₁₆	4 ³ / ₄	3.86	4 ³ / ₄	2 ³ / ₄	9 ¹ / ₈	3 ¹ / ₈	6 ¹¹ / ₁₆	4 ⁵ / ₃₂	1 ¹ / ₂	2 ¹⁹ / ₆₄	2 ²⁵ / ₃₂	5 ¹⁵ / ₁₆	13.50
	2 ¹⁵ / ₁₆	TB22647H																	13.00
B655	3 ⁷ / ₁₆	TB22655H	1 ⁷ / ₈	6.812	1.812	7 ³ / ₈	5 ¹ / ₂	4.29	4 ⁷ / ₈	2 ⁷ / ₈	10	3 ⁷ / ₁₆	7 ¹³ / ₁₆	4 ¹⁵ / ₁₆	1 ⁵ / ₈	2 ³⁷ / ₆₄	3	6 ⁵ / ₁₆	43.10
B663	3 ¹⁵ / ₁₆	TB22663H	2 ¹ / ₈	8.625	2.062	8 ⁷ / ₈	7	4.94	5 ¹ / ₄	3 ¹ / ₈	12 ¹ / ₈	4 ¹ / ₈	9 ⁷ / ₁₆	5 ⁷ / ₁₆	2 ¹ / ₈	2 ¹⁵ / ₃₂	3 ⁷ / ₁₆	7 ¹¹ / ₁₆	76.00

Additional Notes

- Please call 1-866-REXNORD for availability
- Lubrication fitting tap size, 1/8" PT
- Dimensions for "D" & "U" based on unmounted condition
- Take-up slot spacing & width tolerance, +.005 in/- .015 in (**+0.13 mm/-0.38 mm**)
- H labyrinth seals standard
- All size codes available with type E lip seals & E7 triple lip seals

For the Selection Guide, Load Ratings and Speed Limits, see the Link-Belt Spherical Roller Bearings Engineering section on pages 135 - 140.

Note: Dimensions subject to change. Certified dimensions of ordered material furnished on request.

ETPB22400**Interchange:** *TPHUS2, TPE, USTA5000, ETTUTRB***Product Features**

Cast iron Type E housing
 Corrosion resistant powder coating
 Misalignment capabilities - Total of 4°
 Broad range of sealing options
 Factory set clearance & lubrication
 Field interchangeable seals
 See Features and Benefits for additional info on pages 132 - 133.

Bearing Dimensions

Size Code	Shaft Diameter	Part Number	A Base to Centerline Height	C	D	E	F	G	J	K	L	M	N	R	S	Z	Approx. Weight
B432	1 ¹⁵ / ₁₆	ETPB22431H	3 ⁷ / ₃₂	4 1/2	3 1/8	2 ³ / ₈	6	1 ³ / ₈	6 1/2	2	6 ⁷ / ₁₆	2 ⁷ / ₈	4	1 ¹³ / ₁₆	1 ¹⁵ / ₁₆	2 ¹³ / ₃₂	15.00
	2	ETPB22432H															
B436	2 ³ / ₁₆	ETPB22435H	3 ¹⁵ / ₃₂	5 1/4	3 ⁵ / ₁₆	2 ⁷ / ₁₆	6 ³ / ₄	1 ¹³ / ₃₂	7	2 1/4	6 ²⁹ / ₃₂	3 1/4	4 1/2	1 ¹³ / ₁₆	1 ¹⁵ / ₁₆	2 ⁵ / ₈	15.00
B440	2 ⁷ / ₁₆	ETPB22439H	3 1/2	4 ⁷ / ₈	3 1/2	2 ³ / ₄	7	1 ²⁵ / ₃₂	7 1/2	2 ³ / ₈	7 ³ / ₈	3 ⁹ / ₁₆	4 ¹³ / ₁₆	7/8	1 ³ / ₃₂	2 ³ / ₄	21.00
	2 1/2	ETPB22440H															
B448	2 ¹⁵ / ₁₆	ETPB22447H	4 ⁵ / ₆₄	5 ⁷ / ₈	4	2 ³ / ₄	8	1 ¹³ / ₁₆	8 1/2	2 ³¹ / ₃₂	8 ⁷ / ₁₆	4 1/16	5 ¹³ / ₁₆	7/8	1 ³ / ₃₂	3 ⁵ / ₃₂	29.00
	3	ETPB22448H															
B456	3 ⁷ / ₁₆	ETPB22455H	4 1/2	6 ⁷ / ₁₆	4 ³ / ₈	2 ³ / ₄	8 ¹⁵ / ₁₆	2 ³ / ₆₄	9 ³ / ₈	3 1/2	9 1/2	4 ²⁹ / ₃₂	6 ³ / ₄	7/8	1 ³ / ₈	3 ⁷ / ₁₆	41.00
B464	3 ¹⁵ / ₁₆	ETPB22463H	5 1/2	8	5 ¹ / ₁₆	3 ¹ / ₈	10 1/2	2 ¹ / ₁₆	11	3 ¹⁵ / ₁₆	10 ¹⁵ / ₁₆	5 ⁵ / ₈	7 ²¹ / ₃₂	1 ¹⁵ / ₁₆	1 ³ / ₈	4	68.00

Additional Notes

Please call 1-866-REXNORD for availability
 Lubrication fitting tap size, 1/8" PT
 H labyrinth seals standard
 All size codes available with type E lip seals & E7 triple lip seals

For the Selection Guide, Load Ratings and Speed Limits, see the Link-Belt Spherical Roller Bearings Engineering section on pages 135 - 140.

Note: Dimensions subject to change. Certified dimensions of ordered material furnished on request.

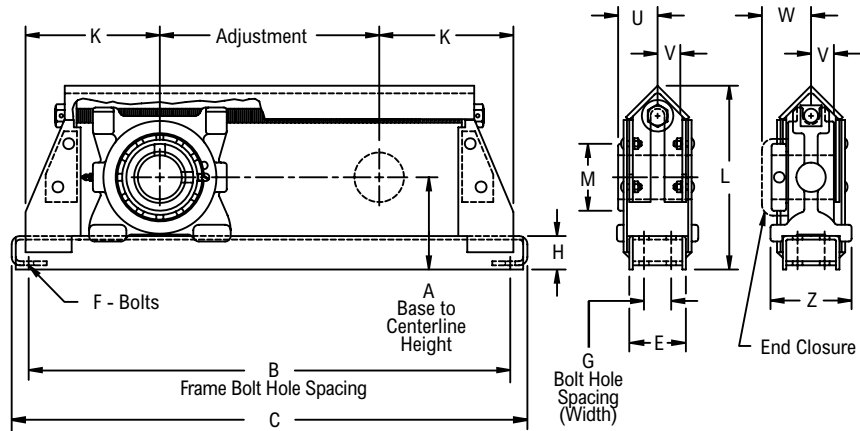
DSB22400



Photo Shows a Hinged Top, Welded Steel Conveyor Take-up Frame with Spherical Roller Bearing Take-up Unit

Product Features

- Protected screw type frame
- Corrosion-resistant powder coating
- Cast iron housing
- Misalignment capabilities - total of 4°
- Broad range of sealing options
- Factory set clearance & lubrication
- Field interchangeable seals
- See Features and Benefits for additional info on pages 132 - 133.



Bearing Dimensions

Size Code	Shaft Diameter	Complete Take-up Assembly	Travel Length	A Base to Centerline Height	B Frame Bolt Hole Spacing	G Bolt Hole Spacing (Width)	C	E	F	H	K	L	M	U	V	W	Z	Adjust.	Approx. Weight
B432	1 15/16	DSB22431H	12 18 24	3 15/16	26 1/2 32 1/2 38 1/2	-	28 1/2 34 1/2 40 1/2	3	5/8	1 3/4	7 1/4	8 1/4	2 7/8	1 29/32	1 1/4	2 9/32	4 1/8	12 18 24	43 49 54
	45.00	DSB224M45H	12 18 24	100.00	673.1 825.5 977.9	-	723.9 876.3 1028.7	76.20	16.00	44.40	184.20	209.60	73.00	48.40	31.80	57.90	104.80	304.8 457.2 609.6	19.5 22.2 24.5
	50.00	DSB224M50H	12 18 24																
B436	2 3/16	DSB22435H	12 18 24	4 3/16	27 1/2 33 1/2 39 1/2	-	29 1/2 35 1/2 41 1/2	3	5/8	1 3/4	7 3/4	8 11/16	3 1/4	2 1/16	1 9/32	2 7/16	4 1/8	12 18 24	49 55 60
	55.00	DSB224M55H	12 18 24	106.40	698.5 850.9 1003.3	-	749.3 901.7 1054.1	76.20	16.00	44.40	196.80	220.70	82.60	52.40	32.50	61.90	104.80	304.8 457.2 609.6	22.2 24.9 27.2
B440	2 7/16	DSB22439H	12 18 24 30	4 3/8	28 1/2 34 1/2 40 1/2 46 1/2	-	30 1/2 36 1/2 42 1/2 48 1/2	3	3/4	1 3/4	8 1/4	9 1/8	3 9/16	2 3/16	1 3/8	2 9/16	4 1/8	12 18 24 30	55 61 66 71
	60.00	DSB224M60H	12 18 24 30	111.10	723.9 876.3 1028.7 1181.1	-	774.7 927.1 1079.5 1231.9	76.20	20.00	44.40	209.60	231.80	90.50	55.60	34.90	65.10	104.80	304.8 457.2 609.6 762.0	24.9 27.2 29.9 32.2
B448	2 15/16	DSB22447H	12 18 24 30	5 1/8	30 1/2 36 1/2 42 1/2 48 1/2	2	32 1/2 38 1/2 44 1/2 50 1/2	4	5/8	2	9 1/4	10 5/8	4 1/16	2 7/16	1 5/8	2 25/32	5 1/8	12 18 24 30	80 89 97 105
	65.00	DSB224M65H	12 18 24 30	130.20	774.4 927.1 1079.5 1231.9	50.80	825.5 977.9 1130.3 1282.7	101.60	16.00	50.80	235.00	269.90	103.20	61.90	41.30	70.60	130.20	304.8 457.2 609.6 762.0	36.3 40.4 44.4 47.6
	70.00	DSB224M70H	12 18 24 30																
B456	3 7/16	DSB22455H	12 18 24 30	5 5/8	32 38 44 50	2	34 1/4 40 1/4 46 1/4 52 1/4	4	3/4	2	10	11 13/16	4 29/32	2 21/32	1 23/32	3	5 5/8	12 18 24 30	107 116 124 132
	80.00	DSB224M80H	12 18 24 30	142.90	812.8 965.2 1117.6 1270.0	50.80	870.0 1022.4 1174.8 1327.2	101.60	20.00	50.80	254.00	300.00	124.60	67.50	43.60	76.20	142.90	304.8 457.2 609.6 762.0	48.5 52.6 56.2 59.9
	85.00	DSB224M85H	12 18 24 30																
B464	3 15/16	DSB22463H	12 18 24 30	7	36 42 48 54	2 1/2	38 1/2 44 1/2 50 1/2 56 1/2	5	3/4	2 1/4	12	14 11/16	5 5/8	3 1/16	2	3 7/16	6 7/8	12 18 24 30	180 192 202 212
	90.00	DSB224M90H	12 18 24 30	177.80	914.4 1066.8 1219.2 1371.6	63.50	977.9 1120.3 1282.7 1435.1	127.00	20.00	57.20	304.80	373.10	142.90	77.80	50.80	87.30	174.60	304.8 457.2 609.6 762.0	81.6 87.1 91.6 96.2
	100.00	DSB224M100H	12 18 24 30																

Additional Notes

- Please call 1-866-REXNORD for availability
- Lubrication fitting tap size, 1/8" PT
- For size code B464, frame has hinged top construction
- Frames with 18 in (457.20 mm) adjustment or more have center supporting pad welded to bottom of frame

- H labyrinth seals standard
- All size codes available with type E lip seals & E7 triple lip seals
- For the Selection Guide, Load Ratings and Speed Limits, see the Link-Belt Spherical Roller Bearings Engineering section on pages 135 - 140.
- Note: Dimensions subject to change. Certified dimensions of ordered material furnished on request.

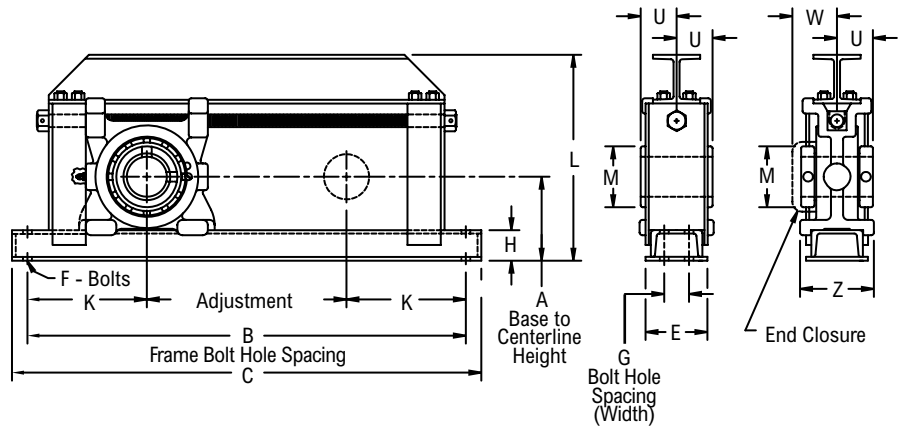
DSHB22500



Photo Shows a Hinged Top, Extra Strength Welded Steel Conveyor Take-up Frame with Spherical Roller Bearing Take-up Unit

Product Features

- Extra strength welded steel frame
- Corrosion-resistant powder coating
- Cast iron housing
- Misalignment capabilities - total of 4°
- Broad range of sealing options
- Factory set clearance & lubrication
- Field interchangeable seals
- See Features and Benefits for additional info on pages 132 - 133.



Bearing Dimensions

Size Code	Shaft Diameter	Complete Take-up Assembly	Travel Length	A Base to Centerline Height	B Frame Bolt Hole Spacing	G Bolt Hole Spacing (Width)	C	E	F	H	K	L	M	U	W	Z	Adjust.	Approx. Weight
B531	1 15/16	DSHB22531H	12	3 15/16	27 1/2	-	29 1/2	3 1/2	5/8	1 3/4	7 3/4	10 5/8	2 7/8	1 29/32	2 9/32	4 1/8	12	78
			18		33 1/2		35 1/2					18					88	
			24		39 1/2		41 1/2					24					98	
B536	2 3/16	DSHB22535H	12	4 7/16	27 1/2	-	29 1/2	4 1/2	5/8	2	7 3/4	11 1/4	3 1/4	2 1/16	2 7/16	5 1/4	12	83
			18		33 1/2		35 1/2					18					93	
			24		39 1/2		41 1/2					24					103	
B540	2 7/16	DSHB22539H	12	4 5/8	28 1/2	-	30 1/2	4 1/2	3/4	2	8 1/4	12 13/16	3 9/16	2 3/16	2 9/16	5 1/4	12	105
			18		34 1/2		36 1/2					18					118	
			24		40 1/2		42 1/2					24					132	
B548	2 15/16	DSHB22547H	12	5 1/8	30 1/2	2	32 1/2	4 1/2	5/8	2	9 1/4	13 15/16	4 1/16	2 7/16	2 25/32	5 1/4	12	125
			18		36 1/2		38 1/2										18	140
			24		42 1/2		44 1/2										24	155
			30		48 1/2		50 1/2										30	170
			36		54 1/2		56 1/2										36	185
B556	3 7/16	DSHB22555H	12	5 5/8	32	2	34 1/4	4 1/2	3/4	2	10	15 1/16	4 29/32	2 21/32	3	5 5/8	12	146
			18		38		40 1/4										18	162
			24		44		46 1/4										24	178
			30		50		52 1/4										30	194
			36		56		58 1/4										36	210
B564	3 15/16	DSHB22563H	12	7	36	2 1/2	38 1/2	5 1/2	3/4	2 1/4	12	17 1/16	5 5/8	3 1/16	3 7/16	6 7/8	12	260
			18		42		44 1/2										18	278
			24		48		50 1/2										24	296
			30		54		56 1/2										30	314
			36		60		62 1/2										36	332

Additional Notes

- Please call 1-866-REXNORD for availability
- Lubrication fitting tap size, 1/8" PT
- H labyrinth seals standard
- All size codes available with type E lip seals & E7 triple lip seals
- For the Selection Guide, Load Ratings and Speed Limits, see the Link-Belt Spherical Roller Bearings Engineering section on pages 135 - 140.

Note: Dimensions subject to change. Certified dimensions of ordered material furnished on request.

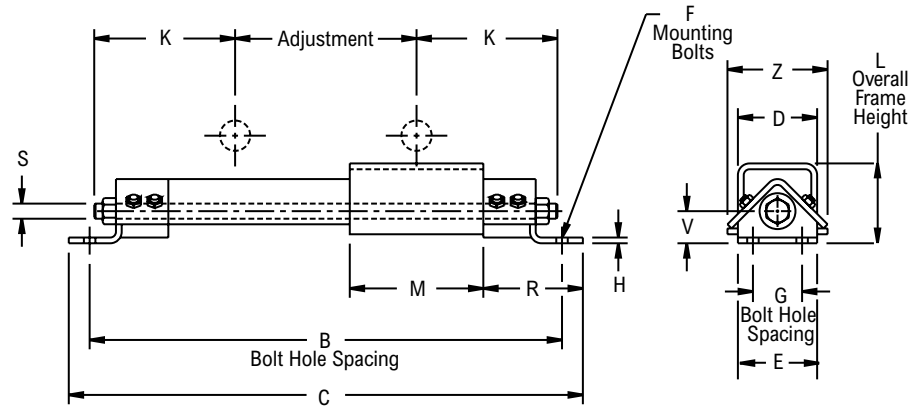
LHD FRAME



Photo Shows a Protected Screw Type Frame

Product Features

- Protected screw type frame
- Welded steel frame



Bearing Dimensions

Size Code	Available Shaft Sizes			Part Number	Adjustment Length	B Bolt Hole Spacing	G Bolt Hole Spacing in Width Direction	L Overall Frame Height	C	D	E	F	H	K	M	R	S	V	Z	Approx. Weight
	PB/PKB 22400/22600 Series	PB22500 Series	EPB22400/22500/22600 Series																	
LHD20	1 3/16-2 1/2	1 7/16-2 7/16	1 7/16-2 1/2	LHD2012	12	29	2 1/2	5 1/4	31	4	5	5/8	1/4	8 1/2	11	4	3/4	2	6 1/4	48.00
				LHD2018	18	35			37											52.00
				LHD2024	24	41			43											56.00
				LHD2030	30	47			49											65.00
				LHD2036	36	53			55											70.00
				LHD2048	48	65			67											81.00
LHD25	2 11/16-3	2 11/16-2 15/16	2 11/16-3	LHD2512	12	32 3/4	3	6 1/4	35 1/4	5	5 1/2	5/8	3/8	10 3/8	13 1/4	5	1	2 9/16	7 1/8	81.00
				LHD2518	18	38 3/4			41 1/4											100.00
				LHD2524	24	44 3/4			47 1/4											110.00
				LHD2530	30	50 3/4			53 1/4											115.00
				LHD2536	36	56 3/4			59 1/4											120.00
				LHD2548	48	68 3/4			71 1/4											127.00
LHD30	3 3/16-3 1/2	3 7/16	-	LHD3012	12	35 1/2	3	7	38 1/4	6	6 1/2	3/4	1/2	11 3/4	14 1/4	6	1	2 1/2	9	158.00
				LHD3018	18	41 1/2			44 1/4											162.00
				LHD3024	24	47 1/2			50 1/4											166.00
				LHD3030	30	53 1/2			56 1/4											173.00
				LHD3036	36	59 1/2			62 1/4											183.00
				LHD3048	48	71 1/2			74 1/4											214.00
LHD35	3 11/16-4	3 15/16-4 1/2	3 3/16-3 1/2	LHD3512	12	37 1/4	3	7	40	6	6 1/2	3/4	1/2	12 5/8	16	6	1 1/4	2 1/2	9	173.00
				LHD3518	18	43 1/4			46											190.00
				LHD3524	24	49 1/4			52											195.00
				LHD3530	30	55 1/4			58											200.00
				LHD3536	36	61 1/4			64											210.00
				LHD3548	48	73 1/4			76											234.00
LHD40	-	4 15/16-5	-	LHD4012	12	41 1/4	3	7	44	7	6 1/2	3/4	1/2	14 5/8	20	6	1 1/2	2 1/2	9 13/16	175.00
				LHD4018	18	47 1/4			50											220.00
				LHD4024	24	53 1/4			56											265.00
				LHD4030	30	59 1/4			62											270.00
				LHD4036	36	65 1/4			68											290.00
				LHD4048	48	77 1/4			80											300.00

Additional Notes

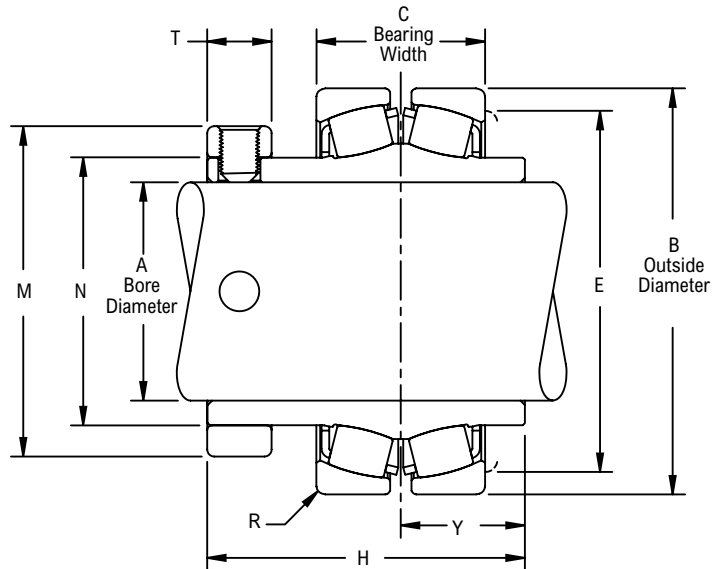
Please call 1-866-REXNORD for availability
 Note: Dimensions subject to change. Certified dimensions of ordered material furnished on request.



Photo Shows an Unmounted Spherical Roller Bearing Unit

Product Features

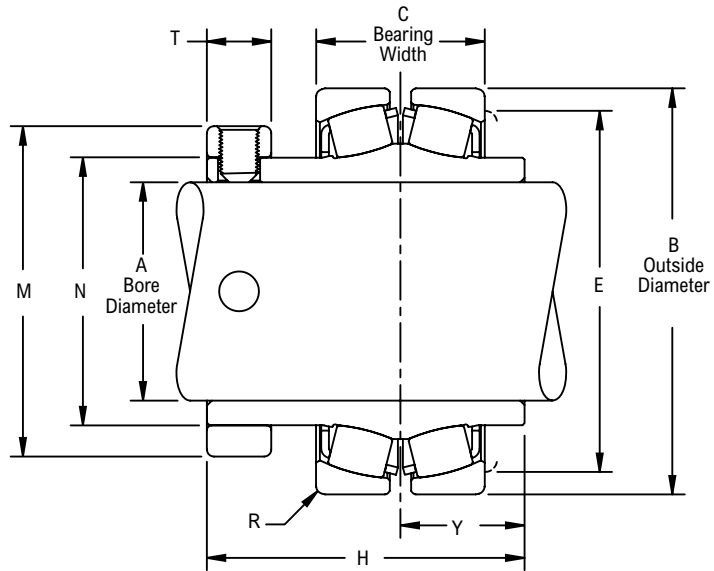
- Hardened spring locking collar
- Self aligning
- See Features and Benefits for additional info on pages 132 - 133.



Bearing Dimensions

Size Code	Shaft Diameter	Part Number	A Bore Diameter	B Outside Diameter	C Bearing Width	E	H	M	N	R	T	Y	Approx. Weight
B416	1	B416L	1.0000	2.3750	1.1880	2	2.56	1.75	1.307	0.046	1/2	1	1.30
	25.00	B4M25L	25.0000	60.3250	30.1800	50.80	65.09	44.40	33.200	1.170	12.70	25.40	0.60
B420	1 3/16	B419L	1.1875	2.6250	1.3120	2 5/16	2.69	1.97	1.532	0.062	1/2	1 1/16	1.80
	1 1/4	B420L	1.2500										
	30.00	B4M30L	30.0000	66.6750	33.3200	58.70	68.26	50.00	38.910	1.570	12.70	26.99	0.80
B424	1 7/16	B423L	1.4375	2.8345	1.3100	2 1/2	2.88	2.31	1.745	0.062	5/8	1 3/32	2.20
	1 1/2	B424L	1.5000										
	35.00	B4M35L	35.0000	72.0000	33.2700	63.50	73.02	58.70	44.320	1.570	15.90	27.78	1.00
B428	1 1/2	B4B24L	1.5000	3.3464	1.5780	2 7/8	3.13	2.59	2.027	0.062	5/8	1 7/32	3.20
	1 5/8	B426L	1.6250										
	1 11/16	B427L	1.6875										
	1 3/4	B428L	1.7500										
B432	40.00	B4M40L	40.0000	85.0000	40.0800	73.00	79.38	65.90	51.480	1.570	15.90	30.96	1.40
	1 3/4	B4B28L	1.7500	3.5433	1.5260	3 3/16	3.13	2.88	2.307	0.078	5/8	1 7/32	3.30
	1 15/16	B431L	1.9375										
	2	B432L	2.0000										
	45.00	B4M45L	45.0000										
50.00	B4M50L	50.0000											
B436	2 3/16	B435L	2.1875	3.9370	1.6560	3 1/2	3.31	3.25	2.620	0.062	3/4	1 1/4	4.60
	2 1/4	B436L	2.2500										
	55.00	B4M55L	55.0000	100.0000	42.0600	88.90	84.14	82.60	66.550	1.570	19.00	31.75	2.10
B440	2 1/4	B4B36L	2.2500	4.3307	1.7500	3 7/8	3.50	3.56	2.901	0.078	13/16	1 5/16	5.80
	2 7/16	B439L	2.4375										
	2 1/2	B440L	2.5000										
	60.00	B4M60L	60.0000	110.0000	44.4500	98.40	88.90	90.50	73.690	1.980	20.60	33.34	2.60
B448	2 11/16	B443L	2.6875	5.1172	2.1250	4 17/32	4.00	4.06	3.370	0.078	13/16	1 9/16	9.50
	2 3/4	B444L	2.7500										
	2 15/16	B447L	2.9375										
	3	B448L	3.0000										
	65.00	B4M65L	65.0000										
	70.00	B4M70L	70.0000										
75.00	B4M75L	75.0000											
B456	3 3/16	B451L	3.1875	5.9045	2.3130	5 11/32	4.38	4.91	3.975	0.125	27/32	1 23/32	13.50
	3 7/16	B455L	3.4375										

Continued...



Continued...

Bearing Dimensions

Size Code	Shaft Diameter	Part Number	A Bore Diameter	B Outside Diameter	C Bearing Width	E	H	M	N	R	T	Y	Approx. Weight
B456	3 1/2	B456L	3.5000	5.9045	2.3130	5 11/32	4.38	4.91	3.975	0.125	27/32	1 23/32	13.50
	80.00	B4M80L	80.0000	149.9740	58.7500	135.70	111.12	124.60	100.970	3.180	21.40	43.66	6.10
	85.00	B4M85L	85.0000										
B464	3 11/16	B459L	3.6875	7.0856	2.7500	6 3/8	5.06	5.63	4.561	0.125	31/32	2	24.00
	3 15/16	B463L	3.9375										
	4	B464L	4.0000										
	90.00	B4M90L	90.0000	179.9740	69.8500	161.90	128.59	142.90	115.850	3.180	24.60	50.80	10.80
	100.00	B4M100L	100.0000										

Additional Notes

Please call 1-866-REXNORD for availability
 Bearing O.D. tolerance, +.001 in/-.000 in (+0.025 mm/-0.000 mm)
 Bore tolerance, +.0010 in/-.0000 in (+0.025 mm/-0.000 mm)
 Bearing width tolerance, +/- .025 in (+/-0.64 mm)
 Housing must allow clearance for this adjustment on dimension "C"

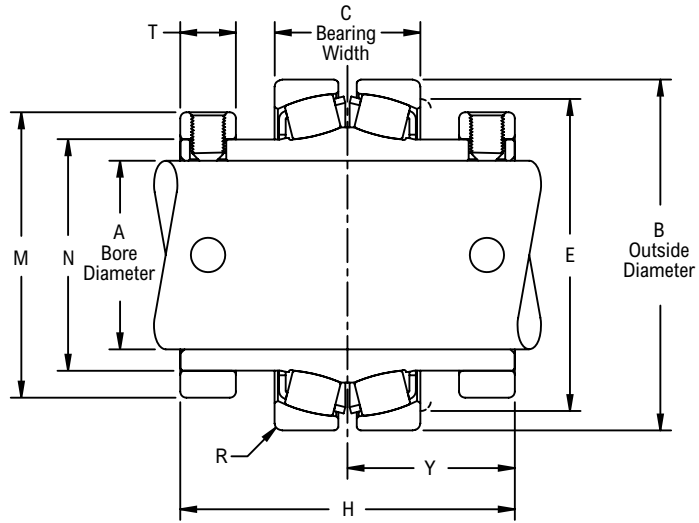
For the Selection Guide, Load Ratings and Speed Limits, see the Link-Belt Spherical Roller Bearings Engineering section on pages 135 - 140.
 Note: Dimensions subject to change. Certified dimensions of ordered material furnished on request.



Photo Shows an Unmounted Spherical Roller Bearing Unit

Product Features

- Two hardened spring locking collars
- Self aligning
- See Features and Benefits for additional info on pages 132 - 133.



Bearing Dimensions

Size Code	Shaft Diameter	Part Number	A Bore Diameter	B Outside Diameter	C Bearing Width	E	H	M	N	R	T	Y	Approx. Weight
B524	1 7/16	B523L	1.4375	2.8345	1.3100	2 1/2	3.56	2.31	1.745	0.062	5/8	1 25/32	2.40
B528	1 11/16	B527L	1.6875	3.3464	1.5780	2 7/8	3.81	2.59	2.027	0.062	5/8	1 29/32	3.50
B531	1 15/16	B531L	1.9375	3.5433	1.5260	3 3/16	3.81	2.88	2.307	0.078	5/8	1 29/32	3.80
B536	2	B532L	2.0000	3.9370	1.6560	3 1/2	4.13	3.25	2.620	0.062	3/4	2 1/16	6.00
	2 3/16	B535L	2.1875										
B540	2 7/16	B539L	2.4375	4.3307	1.7500	3 7/8	4.38	3.56	2.901	0.078	13/16	2 3/16	7.20
B548	2 11/16	B543L	2.6875	5.1172	2.1250	4 17/32	4.88	4.06	3.370	0.078	13/16	2 7/16	11.10
	2 15/16	B547L	2.9375										
B556	3 7/16	B555L	3.4375	5.9045	2.3130	5 11/32	5.31	4.91	3.975	0.125	27/32	2 21/32	15.70
B564	3 15/16	B563L	3.9375	7.0856	2.7500	6 3/8	6.13	5.63	4.561	0.125	31/32	3 1/16	26.70
	4	B564L	4.0000										
B572	4 3/16	B567YL	4.1875	7.6815	2.679	6.875	6.25	6.19	5.032	0.145	1	3 1/8	37.00
	4 7/16	B571YL	4.4375										
	4 1/2	B572YL	4.5000										
	110.00	B5M110YL	110.0000										
	115.00	B5M115YL	115.0000	195.1101	68.0491	175	158.75	157.23	127.813	3.683	25.40	79.38	16.70
B580	4 15/16	B579YL	4.9375	9.0574	3.5562	8.125	7.88	7.04	5.750	0.145	1 1/16	3 15/16	41.20
	5	B580YL	5.0000										
	125.00	B5M125YL	125.0000										

Additional Notes

- Please call 1-866-REXNORD for availability
- Bearing O.D. tolerance, +.001 in/-.000 in (+0.025 mm/-0.000 mm)
- Bore tolerance, +.0010 in/-.0000 in (+0.025 mm/-0.000 mm)
- Bearing width tolerance, +/- .025 in (+/- 0.64 mm)
- Housing must allow clearance for this adjustment on dimension "C"

For the Selection Guide, Load Ratings and Speed Limits, see the Link-Belt Spherical Roller Bearings Engineering section on pages 135 - 140.
 Note: Dimensions subject to change. Certified dimensions of ordered material furnished on request.

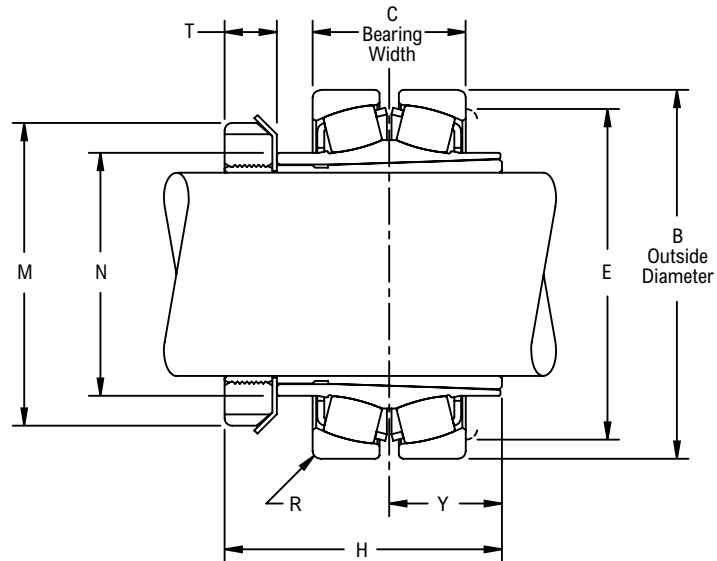
B600L



Photo Shows an Unmounted Spherical Roller Bearing Unit

Product Features

- Enhanced life mounting style
- Self aligning
- See Features and Benefits for additional info on pages 132 - 133.



Bearing Dimensions

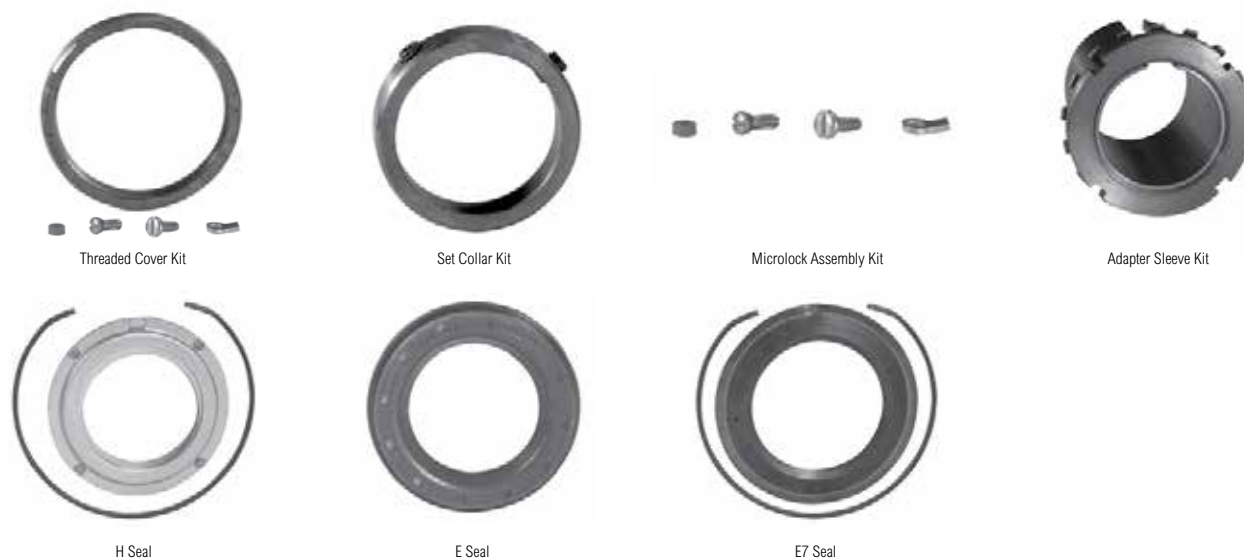
Size Code	Shaft Diameter	Part Number	B Outside Diameter	C Bearing Width	E	H	M	N	R	T	Y	Approx. Weight
B624	1 7/16	B623L	2.8345	1.3100	2 1/2	2.71	2 1/4	1.745	0.062	1/2	1 3/32	2.10
B631	1 15/16	B631L	3.5433	1.5260	3 3/16	3.08	2 31/32	2.307	0.078	9/16	1 7/32	3.30
B635	2 3/16	B635L	3.9370	1.6560	3 1/2	3.16	3 5/32	2.620	0.062	19/32	1 1/4	4.50
B639	2 7/16	B639L	4.3307	1.7500	3 7/8	3.36	3 5/8	2.901	0.078	5/8	1 5/16	5.90
B647	2 11/16	B643L	5.1172	2.1250	4 17/32	3.86	4 5/32	3.370	0.078	43/64	1 9/16	9.50
	2 15/16	B647L										
B655	3 7/16	B655L	5.9045	2.3130	5 11/32	4.31	4 15/16	3.975	0.125	51/64	1 23/32	12.80
B663	3 15/16	B663L	7.0856	2.7500	6 3/8	4.94	5 7/16	4.561	0.125	55/64	2	23.20

Additional Notes

- Please call 1-866-REXNORD for availability
- Dimension for "H" based on unmounted condition
- Bearing O.D. tolerance, +.001 in/- .000 in (+0.025 mm/-0.000 mm)
- Bore tolerance, +.0010 in/- .0000 in (+0.025 mm/-0.000 mm)
- Bearing width tolerance, +/- .025 in (+/-0.64 mm)
- Housing must allow clearance for this adjustment on dimension "C"

For the Selection Guide, Load Ratings and Speed Limits, see the Link-Belt Spherical Roller Bearings Engineering section on pages 135 - 140.

Note: Dimensions subject to change. Certified dimensions of ordered material furnished on request.



Bearing Dimensions

Size Code	H	E	E7	Threaded Cover Kit	Set Collar Kit	Microlock Assembly Kit	Adapter Assembly Kit
B416	B417HS	B417ES	-	B417TC	B417SC	B436MLK*	-
B420	B420HS	B420ES	B420E7S	B420TC	B420SC	B436MLK*	-
B424 B524 B624	B424HS	B424ES	B424E7S	B424TC	B424SC	B436MLK*	SNW623
B428 B528	B428HS	B428ES	B428E7S	B428TC	B428SC	B436MLK*	-
B432 B531 B631	B432HS	B432ES	B432E7S	B432TC	B432SC	B436MLK*	SNW631
B436 B536 B635	B436HS	B436ES	B436E7S	B436TC	B436SC	B436MLK*	SNW635
B440 B540 B639	B440HS	B440ES	B440E7S	B440TC	B440SC	B448MLK▶	SNW639
B448 B548 B647	B448HS	B448ES	B448E7S	B448TC	B448SC	B448MLK▶	SNW647
B456 B556 B655	B456HS	B456ES	B456E7S	B456TC	B456SC	B580MLK◇	SNW655
B464 B564 B663	B464HS	B464ES	B464E7S	B464TC	B464SC	B580MLK◇	SNW663
B572	B572YHS	B572YES	B572YE7S	B572YTC	B572Y5S	B580YMLK◇	-
B580	B580YHS	B580YES	B580YE7S	B580YTC	B580Y5S	B580YMLK◇	-

Additional Notes

- * CB cartridge blocks in these size codes require B436MLK1 Microlock Kit
- ▶ CB cartridge blocks in these size codes require B456MLK Microlock Kit
- ◇ CB cartridge blocks in these size codes require B572MLK Microlock Kit

Spherical Roller Bearings

Units: Rexnord PT Select Series



Contents

	Page
Features and Benefits	192
Nomenclature	193
Engineering	194
Dimensions	
Pillow Blocks	198
Flange Blocks	201

Industries Served

Aggregates
Air & Fluid Handling
Cement
Construction
Material Handling
Package Handling



Rexnord PT Select Series Spherical Roller Bearings

1. Rugged cast iron housing
2. Total misalignment capability up to 2 degrees
3. Expansion and non-expansion units available
4. 90-degree mounting collar for superior holding strength

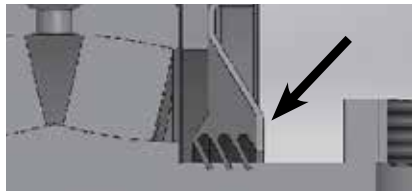


Additional Features and Benefits

- State-of-the-art design allows increased strength while optimizing material
- Industry-standard dimensions for interchangeability with leading brands
- Standard, off-the-shelf sizes for quick turnarounds needs
- Field installable/removable safety caps that are compatible with standard housings
- Rugged metal retainer for increased strength and durability
- Shaft ready and pre-lubricated with our standard grease for normal operation

Seal Types

Type T Triple Lip Seal

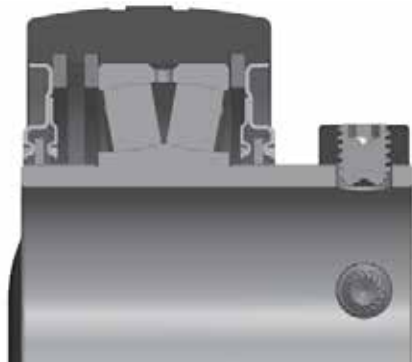


Three points of contact (shown above) provide superior ingress protection against contaminants.

Engineered bearing seals for increased product life

Designed for efficiency while maintaining the overall product strength, the bearing delivers the seal performance your environment requires.

- Standard triple lip and clearance seal provides maximum ingress protection against contaminants which are a leading cause of bearing failure (optional labyrinth seal available)
- Clearance seal reduces operating temperatures at higher speeds
- Features nitrile material with protective metal shield



Type C Clearance Seal

Also Available with These Housings



2-bolt Pillow Block

4-bolt Pillow Block

2-bolt Pillow Block — Type E

Flange Block

Flange Block — Type E

Piloted Flange

Nomenclature

Symbol	Description		P2B	-	107	-	C	E							
EFB	Type E Flanged Unit; 4-bolt square	-----	-----	-----	-----	-----	-----	-----							
EP2B	Type E 2-Bolt Pillow Block														
FB	Flanged Unit; 4-bolt square														
FC	Flanged Cartridge Unit; 4-bolt round														
P2B	2-Bolt Pillow Block	-----	-----	-----	-----	-----	-----	-----							
P4B	4-Bolt Pillow Block														
107	1-7/16"														
111	1-11/16"														
115	1-15/16"														
203	2-3/16"														
207	2-7/16"														
208	2-1/2"														
211	2-11/16"														
215	2-15/16"														
307	3-7/16"														
308	3-1/2"														
315	3-15/16"														
407	4-7/16"														
T	Triple Lip Seal								-----	-----	-----	-----	-----	-----	-----
C	Clearance Seal														
Blank	Fixed	-----	-----	-----	-----	-----	-----	-----							
E	Expansion														

Cap Kit Part Numbers

Size Code	Shaft Size	Open Cap	Closed Cap
4	1-7/16"	B1076D	B1086
5	1-11/16"	B1116D	B1126
6	1-15/16"	B1156D	B2006
7	2-3/16"	B2036D	B2046
8	2-7/16"	B2076D	B2086
8	2-1/2"	B2086D	
9	2-11/16"	B2116D	B3006
9	2-15/16"	B2156D	
10	3-7/16"	B3076D	B3086
10	3-1/2"	B3086D	
11	3-15/16"	B3156D	B4006
12	4-7/16"	B4076D	B4086

Caps sold separately and can be added to any housing style

Rexnord PT Select Series Spherical Roller Bearing Selection Guide

To select a bearing, determine the applied radial load, the applied thrust load, the desired Rating Life, and applicable operating conditions. The procedure shown here will aid in selecting a bearing to meet an L₁₀ design life. The formulas for calculating life expectancy should be used to determine the Rating Life L₁₀ for the bearing selected.

The selection procedures and rating formulas shown here are in agreement with the American Bearing Manufacturers Association (ABMA) standards and ANSI/

ABMA Standards STD 11-1990. Ratings are based on fatigue life. The Rating Life L₁₀ or fatigue life at 90% reliability is the usual basis for bearing selection. For radial load applications only, Table 3, can be used to select a bearing or to determine L₁₀ life expectancy.

To assure a satisfactory bearing application, fitting practice, mounting, lubrication, sealing, static rating, housing strength, operating conditions and maintenance must be considered.

Steps for Selection

Step 1

Determine an appropriate L₁₀ design life.

Type of service	Operating time, hours per year	Design life, years	L ₁₀ design life, hours
Light seasonal usage	500 to 750	3-5	3,000
Heavy seasonal usage	1,400 to 1,600	4-6	8,000
Industrial—8 hour shift	2,000	10	20,000
Industrial—16 hour shift	4,000	10	40,000
Industrial—continuous	8,700	10	80,000 to 100,000

Step 2

Determine a required $\left(\frac{C}{P}\right)$ from Table 1.

Step 3

Calculate the required C and select a roller bearing.

a For radial load only:

$$P = F_r$$

$$\text{required } C = \left(\frac{C}{P}\right) P \text{ using } \left(\frac{C}{P}\right) \text{ from Step 2}$$

Select a roller bearing from Table 2 with a basic load rating C equal to or greater than the required C.

Step 3 (continued)

b For combined radial and thrust loads:

Select a trial roller bearing of the desired shaft size from Table 2.

Calculate the ratio of thrust load F_a to the radial load F_r .

$$\frac{F_a}{F_r}$$

Calculate the equivalent radial load P

$$P = X F_r + Y F_a$$

If $\frac{F_a}{F_r}$ is equal to or less than e, then $P = X_1 F_r + Y_1 F_a$

If $\frac{F_a}{F_r}$ is greater than e, then $P = X_2 F_r + Y_2 F_a$

For values of e, X₁, Y₁, X₂, and Y₂, see Table 2.

Calculate the required C

$$\text{required } C = \left(\frac{C}{P}\right) P \text{ using } \left(\frac{C}{P}\right) \text{ from Step 2.}$$

Consult Table 2, basic load rating. If a smaller bearing meets, or nearly meets, the required C, its life expectancy can be calculated.

Note: If the load P is greater than .25C, consult Rexnord Bearing Division.

Selection

Symbols for formulas:

- C = basic load rating, pounds (or newtons)
- Co = static load rating, pounds (or newtons)
- e = a reference value
- Fa = thrust load, pounds (or newtons)
- Fr = radial load, pounds (or newtons)
- L10 = rating life, hours
- n = speed, revolutions per minute
- P = equivalent radial load, pounds (or newtons)
- X = radial factor
- Y = thrust factor

Table 1 • Relation of L₁₀ life and speed to $\left(\frac{C}{P}\right)$

Bearing Life Hours L ₁₀	Speed, n									
	50	100	200	300	400	500	600	700	800	
3000	1.93	2.38	2.93	3.31	3.61	3.86	4.07	4.27	4.44	
4000	2.11	2.59	3.19	3.61	3.93	4.20	4.44	4.65	4.84	
5000	2.25	2.77	3.42	3.86	4.20	4.50	4.75	4.97	5.18	
6000	2.38	2.93	3.61	4.07	4.44	4.75	5.02	5.25	5.47	
8000	2.59	3.19	3.93	4.44	4.84	5.18	5.47	5.73	5.96	
10000	2.77	3.42	4.20	4.75	5.18	5.54	5.85	6.12	6.37	
12000	2.93	3.61	4.44	5.02	5.47	5.85	6.18	6.47	6.73	
14000	3.07	3.78	4.65	5.25	5.73	6.12	6.47	6.77	7.05	
16000	3.19	3.93	4.84	5.47	5.96	6.37	6.73	7.05	7.34	
18000	3.31	4.07	5.02	5.66	6.18	6.60	6.97	7.30	7.60	
20000	3.42	4.20	5.18	5.85	6.37	6.81	7.20	7.54	7.85	
25000	3.65	4.50	5.54	6.25	6.81	7.29	7.70	8.06	8.39	
30000	3.86	4.75	5.85	6.60	7.20	7.70	8.13	8.51	8.86	
35000	4.04	4.97	6.12	6.92	7.54	8.06	8.51	8.92	9.28	
40000	4.20	5.18	6.37	7.20	7.85	8.39	8.86	9.28	9.66	
45000	4.36	5.36	6.60	7.46	8.13	8.69	9.18	9.61	10.00	
50000	4.50	5.54	6.81	7.70	8.39	8.97	9.48	9.92	10.30	
60000	4.75	5.85	7.20	8.13	8.86	9.48	10.00	10.50	10.90	
70000	4.97	6.12	7.54	8.51	9.28	9.92	10.50	11.00	11.40	
80000	5.18	6.37	7.85	8.86	9.66	10.30	10.90	11.40	11.90	
90000	5.36	6.60	8.13	9.18	10.00	10.70	11.30	11.80	12.30	
100000	5.54	6.81	8.39	9.48	10.30	11.00	11.70	12.20	12.70	
150000	6.25	7.70	9.48	10.70	11.70	12.50	13.20	13.80	14.40	
200000	6.81	8.39	10.30	11.70	12.70	13.60	14.40	15.00	15.70	

Bearing Life Hours L ₁₀	Speed, n									
	900	1000	1200	1500	1800	2400	3000	3600	6000	
3000	4.60	4.75	5.02	5.36	5.66	6.18	6.60	6.97	8.13	
4000	5.02	5.18	5.47	5.85	6.18	6.73	7.20	7.60	8.86	
5000	5.36	5.54	5.85	6.25	6.60	7.20	7.70	8.13	9.48	
6000	5.66	5.85	6.18	6.60	6.97	7.60	8.13	8.59	10.00	
8000	6.18	6.37	6.73	7.20	7.60	8.29	8.86	9.36	10.90	
10000	6.60	6.81	7.20	7.70	8.13	8.86	9.48	10.00	11.70	
12000	6.97	7.20	7.60	8.13	8.59	9.36	10.00	10.60	12.30	
14000	7.30	7.54	7.96	8.51	8.99	9.80	10.50	11.10	12.90	
16000	7.60	7.85	8.29	8.86	9.36	10.20	10.90	11.50	13.40	
18000	7.88	8.13	8.59	9.18	9.70	10.60	11.30	11.90	13.90	
20000	8.13	8.39	8.86	9.48	10.00	10.90	11.70	12.30	14.40	
25000	8.69	8.97	9.48	10.10	10.70	11.70	12.50	13.20	15.40	
30000	9.18	9.48	10.00	10.70	11.30	12.30	13.20	13.90	16.20	
35000	9.61	9.92	10.50	11.20	11.80	12.90	13.80	14.60	17.00	
40000	10.00	10.30	10.90	11.70	12.30	13.40	14.40	15.20	17.70	
45000	10.40	10.70	11.30	12.10	12.80	13.90	14.90	15.70	18.30	
50000	10.70	11.00	11.70	12.50	13.20	14.40	15.40	16.20	18.90	
60000	11.30	11.70	12.30	13.20	13.90	15.20	16.20	17.10	20.00	
70000	11.80	12.20	12.90	13.80	14.60	15.90	17.00	17.90	20.90	
80000	12.30	12.70	13.40	14.40	15.20	16.50	17.70	18.70	21.80	
90000	12.80	13.20	13.90	14.90	15.70	17.10	18.30	19.40	22.60	
100000	13.20	13.60	14.40	15.40	16.20	17.70	18.90	20.00	23.30	
150000	14.90	15.40	16.20	17.30	18.30	20.00	21.40	22.60	26.30	
200000	16.20	16.70	17.70	18.90	20.00	21.80	23.30	24.60	28.70	

Basic Formula

$$\left(\frac{C}{P}\right) = \left(\frac{L_{10} \times n \times 60}{1,000,000}\right)^{3/10}$$

$$L_{10} = \frac{\left(\frac{C}{P}\right)^{10/3} \times 1,000,000}{n \times 60}$$

Life Expectancy

To calculate the Rating Life L₁₀ of any selected or trial bearing:

Step 1

Determine the equivalent radial load P.

a For radial load only:

$$P = F_r$$

b For combined radial and thrust load:

$$P = X F_r + Y F_a$$

if $\frac{F_a}{F_r}$ is equal to or less than e, then

$$P = X_1 F_r + Y_1 F_a$$

if $\frac{F_a}{F_r}$ is greater than e, then

$$P = X_2 F_r + Y_2 F_a$$

For values of e, X₁, Y₁, X₂, and Y₂, consult the appropriate bearing rating Table 2.

Step 2

Calculate the ratio of the basic load rating C to the equivalent radial load.

$$\left(\frac{C}{P}\right)$$

Step 3

Approximate the bearing life from Table 1.

Life Adjustment

The Rating Life, L₁₀, may be modified for some applications in accordance with the formula

$$L_n = a_1 a_2 a_3 L_{10}$$

where L_n = Adjusted life for (100-n) % reliability,

a₁ = Life adjustment factor for reliability

a₂ = Life adjustment factor

for material and processing

a₃ = Life adjustment factor for operating conditions.

For most normal applications, all factors will be taken as 1, and the Rating Life used as the selection basis or life estimate. In addition, as long as standard catalog bearings are used, a₂ will be normally set equal to one.

The factor a₃ covers such things as lubrication, misalignment, and temperature. Some conditions that could yield a₃ significantly different than unity include speeds less than 20000 DN or greater than 200000 DN, temperatures below -40°F (-40°C) or above 275°F (135°C). For other possible conditions, as well as additional information on life adjustment factors, consult Rexnord Bearing Division.

Table 2 • Load Ratings and Speed Limits

Size Code	C Dynamic Load Rating		Co Static Load Rating		Approximate speed limit RPM*		e	Fa/Fr ≤ e		Fa/Fr > e	
	pounds	newtons	pounds	newtons	Clearance Seal	Triple Lip Seal		X1	Y1	X2	Y2
4	20,000	88,964	21,360	95,014	4,040	3,490	0.27	1.00	2.49	0.67	3.71
5	20,500	91,189	23,240	103,377	3,820	3,300	0.27	1.00	2.51	0.67	3.74
6	21,000	93,413	24,710	109,916	3,540	3,060	0.25	1.00	2.69	0.67	4.00
7	26,200	116,543	30,590	136,071	3,150	2,720	0.22	1.00	3.05	0.67	4.54
8	38,400	170,812	43,870	195,143	2,670	2,310	0.26	1.00	2.62	0.67	3.90
9	41,000	182,377	48,420	215,383	2,420	2,090	0.23	1.00	2.89	0.67	4.30
10	64,000	284,686	77,880	346,428	1,980	1,710	0.24	1.00	2.76	0.67	4.11
11	80,000	355,858	98,600	438,595	1,760	1,520	0.25	1.00	2.72	0.67	4.05
12	99,200	441,264	129,440	575,778	1,600	1,380	0.26	1.00	2.61	0.67	3.88

If the load P is greater than 25% of C, consult Rexnord Bearing Division.

For setscrew mounted bearings, reduce C Dynamic Load rating by 15%.

For vertical shaft application, consult Rexnord Bearing Division.

*Based on grease lubrication and moderate load.

Table 3 • Radial Load Ratings in Pounds at Various RPM for Appropriate L₁₀ Life Hours

Size Code		50	100	200	300	400	500	600	700	800	900	1000	1200	1500	1800	2000	2500	3000	3500
4	8000	*	*	*	4503	4131	3863	3658	3492	3355	3239	3138	2971	2779	2631	2549	2384	2257	2155
	20000	*	4756	3863	3421	3138	2935	2779	2653	2549	2460	2384	2257	2111	1998	1936	1811	1715	1637
	40000	4756	3863	3138	2779	2549	2384	2257	2155	2070	1998	1936	1833	1715	1623	1573	1471	1393	1330
	100000	3613	2935	2384	2111	1936	1811	1715	1637	1573	1518	1471	1393	1302	1233	1195	1117	1058	1010
5	8000	*	*	*	4616	4234	3960	3749	3580	3439	3320	3216	3045	2848	2696	2613	2443	2313	
	20000	*	4875	3960	3506	3216	3008	2848	2719	2613	2522	2443	2313	2164	2048	1985	1856	1757	
	40000	4875	3960	3216	2848	2613	2443	2313	2209	2122	2048	1985	1879	1757	1664	1612	1508	1427	
	100000	3704	3008	2443	2164	1985	1856	1757	1678	1612	1556	1508	1427	1335	1264	1225	1145	1084	
6	8000	*	*	*	4728	4337	4057	3841	3667	3523	3401	3295	3120	2918	2762	2676	2503	2370	
	20000	*	4994	4057	3592	3295	3082	2918	2786	2676	2583	2503	2370	2216	2098	2033	1901	1800	
	40000	4994	4057	3295	2918	2676	2503	2370	2263	2174	2098	2033	1925	1800	1704	1651	1544	1462	
	100000	3794	3082	2503	2216	2033	1901	1800	1719	1651	1594	1544	1462	1368	1295	1254	1173	1111	
7	8000	*	*	*	5899	5411	5061	4792	4575	4395	4243	4111	3892	3640	3446	3339	3123		
	20000	*	6231	5061	4481	4111	3845	3640	3476	3339	3223	3123	2957	2765	2618	2537	2372		
	40000	6231	5061	4111	3640	3339	3123	2957	2823	2712	2618	2537	2402	2246	2126	2060	1927		
	100000	4733	3845	3123	2765	2537	2372	2246	2145	2060	1989	1927	1824	1706	1615	1565	1464		
8	8000	*	*	*	8646	7931	7418	7023	6705	6442	6219	6025	5704	5335	5051	4894			
	20000	*	9132	7418	6568	6025	5635	5335	5094	4894	4724	4577	4333	4053	3837	3718			
	40000	9132	7418	6025	5335	4894	4577	4333	4138	3975	3837	3718	3520	3292	3117	3020			
	100000	6937	5635	4577	4053	3718	3477	3292	3143	3020	2915	2824	2674	2501	2368	2294			
9	8000	*	*	*	9232	8468	7920	7498	7159	6878	6640	6433	6091	5696	5393	5225			
	20000	*	9751	7920	7013	6433	6016	5696	5439	5225	5044	4887	4627	4327	4097	3969			
	40000	9751	7920	6433	5696	5225	4887	4627	4418	4244	4097	3969	3758	3515	3328	3224			
	100000	7407	6016	4887	4327	3969	3712	3515	3356	3224	3112	3015	2855	2670	2528	2449			
10	8000	*	*	*	14410	13219	12363	11705	11176	10737	10364	10042	9507	8892					
	20000	*	15220	12363	10947	10042	9391	8892	8490	8156	7873	7628	7222	6755					
	40000	15220	12363	10042	8892	8156	7628	7222	6896	6625	6395	6196	5866	5486					
	100000	11562	9391	7628	6755	6196	5795	5486	5238	5033	4858	4707	4456	4168					
11	8000	*	*	*	18013	16523	15453	14631	13970	13421	12955	12552	11884						
	20000	*	19025	15453	13684	12552	11739	11115	10612	10196	9842	9535	9028						
	40000	19025	15453	12552	11115	10196	9535	9028	8620	8281	7994	7745	7333						
	100000	14453	11739	9535	8443	7745	7244	6858	6548	6291	6073	5884	5570						
12	8000	*	*	*	22336	20489	19162	18142	17322	16642	16064	15565	14736						
	20000	*	23592	19162	16968	15565	14557	13782	13159	12642	12204	11824	11194						
	40000	23592	19162	15565	13782	12642	11824	11194	10689	10269	9912	9604	9093						
	100000	17922	14557	11824	10470	9604	8982	8504	8120	7801	7530	7296	6907						

If the load P is greater than 25% of the C, consult Rexnord Bearing Division.

For setscrew mounted bearings, reduce C Dynamic Load rating by 15%.

For vertical shaft application, consult Rexnord Bearing Division.

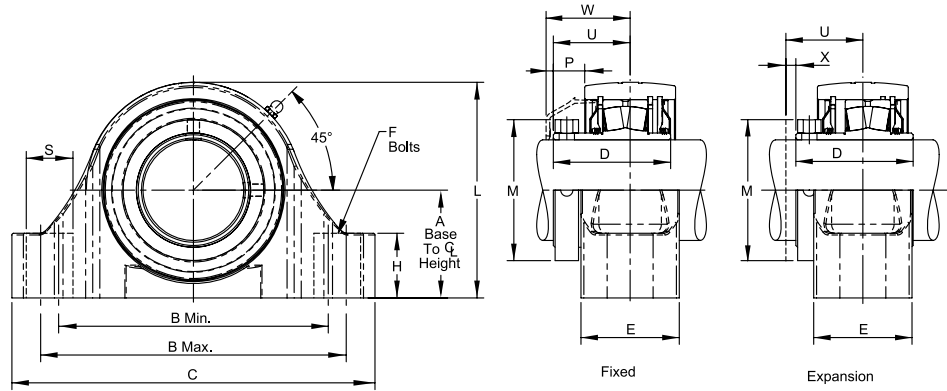
*Based on grease lubrication and moderate load.

P2B



Product Features

- Corrosion-resistant powder coating
- Cast iron housing
- Misalignment capabilities - total of 2°
- Triple lip seal standard; optional clearance seal
- Factory lubricated
- 90° grease fitting standard; straight fitting provided in box



Bearing Dimensions

Size Code	Shaft Diameter	Fixed Part Number	Expansion Part Number	A Base to Centerline Height	B Distance Between Bolt Holes		C	D	E	F Bolts	H	L	M	P	S	U	W	X	Approx. Weight
					Min	Max													
					4	1-7/16													
5	1-11/16	P2B-111-T	P2B-111-TE	2.13	5.31	5.70	7.12	2.76	2.06	1/2	1.25	4.27	2.58	0.91	0.82	1.84	2.11	0.23	6.20
6	1-15/16	P2B-115-T	P2B-115-TE	2.25	6.06	6.44	7.99	2.84	2.13	5/8	1.31	4.49	2.88	1.07	0.94	1.95	2.22	0.26	7.18
7	2-3/16	P2B-203-T	P2B-203-TE	2.50	6.56	6.94	8.49	2.99	2.63	5/8	1.50	5.00	3.25	0.95	0.94	2.06	2.33	0.26	10.11
8	2-7/16	P2B-207-T	P2B-207-TE	2.75	6.94	7.31	8.86	3.55	2.81	5/8	1.63	5.59	3.55	1.23	0.94	2.42	2.69	0.34	13.94
	2-1/2	P2B-208-T	P2B-208-TE																
9	2-11/16	P2B-211-T	P2B-211-TE	3.25	7.94	8.31	10.29	3.65	3.08	3/4	1.88	6.32	4.04	1.09	1.06	2.48	2.75	0.35	18.70
	2-15/16	P2B-215-T	P2B-215-TE																
10	3-7/16	P2B-307-T	P2B-307-TE	3.75	9.38	10.63	12.63	4.12	3.42	7/8	2.25	7.50	4.90	1.13	1.63	2.71	2.98	0.34	29.03
	3-1/2	P2B-308-T	P2B-308-TE																
11	3-15/16	P2B-315-T	P2B-315-TE	4.25	10.62	12.88	15.11	4.64	3.94	1	2.44	8.38	5.63	1.46	2.26	3.05	3.35	0.34	44.29

Additional Notes

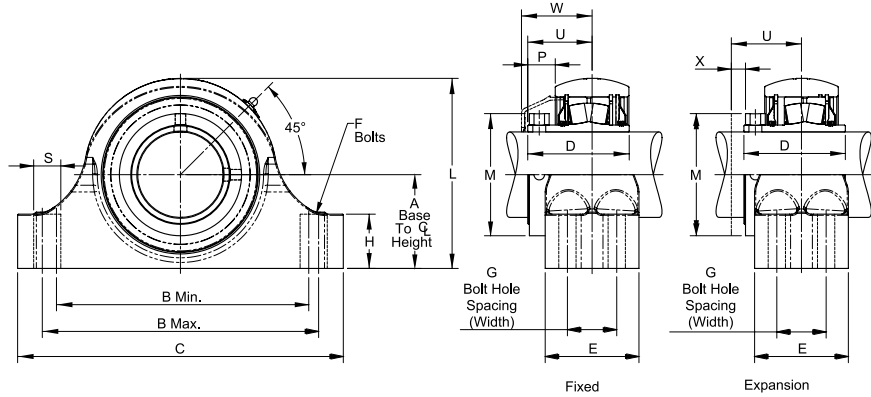
- Please call 1-866-REXNORD for availability
- Lubrication fitting tap size, 1/8" PT
- Bore size = nominal shaft size +.001 in/-.000 in (**+0.03 mm/-0.00 mm**)
- Base to centerline tolerance, +/- .005"
- Open and Closed End Caps available on all shaft sizes
- For Selection Guide, Load Ratings and Speed Limits see Rexnord PT Select Series Engineering section on pages 194 - 197.
- Note: Dimensions subject to change. Certified dimensions of ordered material furnished on request.

P4B



Product Features

- Corrosion-resistant powder coating
- Cast iron housing
- Misalignment capabilities - total of 2°
- Triple lip seal standard; optional clearance seal
- Factory lubricated
- 90° grease fitting standard; straight fitting provided in box



Bearing Dimensions

Size Code	Shaft Diameter	Fixed Part Number	Expansion Part Number	A Base to Centerline Height	B Distance Between Bolt Holes		C	D	E	F Bolts	G Bolt Hole Spacing (Width)	H	L	M	P	S	U	W	X	Approx. Weight
					Min	Max														
6	1-15/16	P4B-115-T	P4B-115-TE	2.25	6.06	6.44	7.70	2.84	3.00	1/2	1.59	1.31	4.50	2.88	1.05	0.81	1.95	2.22	0.26	8.61
7	2-3/16	P4B-203-T	P4B-203-TE	2.50	6.56	6.94	8.36	2.99	3.25	1/2	1.69	1.50	5.00	3.25	0.95	0.81	2.06	2.33	0.26	12.24
8	2-7/16	P4B-207-T	P4B-207-TE	2.75	6.94	7.31	8.74	3.55	3.38	1/2	1.75	1.63	5.59	3.55	1.12	0.81	2.42	2.69	0.34	15.25
	2-1/2	P4B-208-T	P4B-208-TE																	
9	2-11/16	P4B-211-T	P4B-211-TE	3.25	7.94	8.31	9.86	3.65	3.75	5/8	1.88	1.88	6.44	4.04	1.09	0.94	2.48	2.75	0.35	21.83
	2-15/16	P4B-215-T	P4B-215-TE																	
10	3-7/16	P4B-307-T	P4B-307-TE	3.75	9.38	10.62	12.40	4.12	4.50	3/4	2.00	2.25	7.56	4.90	1.13	1.50	2.71	2.98	0.34	35.70
	3-1/2	P4B-308-T	P4B-308-TE																	
11	3-15/16	P4B-315-T	P4B-315-TE	4.25	12.13	12.87	14.75	4.64	4.50	3/4	2.25	2.44	8.44	5.63	1.08	1.25	3.05	3.35	0.34	50.41
12	4-7/16	P4B-407-T	P4B-407-TE	4.75	13.00	14.00	16.50	5.14	4.75	3/4	2.50	2.75	9.63	6.19	1.39	1.38	3.26	3.56	0.34	67.83

Additional Notes

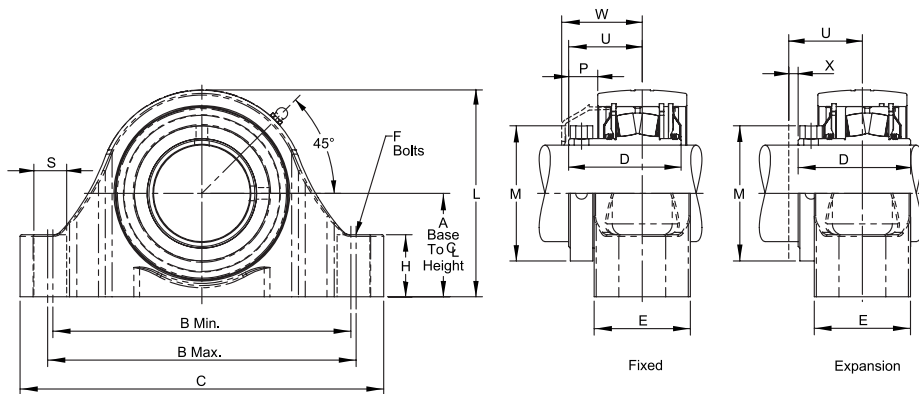
- Please call 1-866-REXNORD for availability
- Lubrication fitting tap size, 1/8" PT
- Bore size = nominal shaft size +.001 in/-.000 in (*+0.03 mm/-0.00 mm*)
- Base to centerline tolerance, +/- .005"
- Open and Closed End Caps available on all shaft sizes
- For Selection Guide, Load Ratings and Speed Limits see Rexnord PT Select Series Engineering section on pages 194 - 197.
- Note: Dimensions subject to change. Certified dimensions of ordered material furnished on request.

EP2B



Product Features

- Type E Interchange
- Corrosion-resistant powder coating
- Cast iron housing
- Misalignment capabilities - total of 2°
- Triple lip seal standard; optional clearance seal
- Factory lubricated
- 90° grease fitting standard; straight fitting provided in box



Bearing Dimensions

Size Code	Shaft Diameter	Fixed Part Number	Expansion Part Number	A Base to Centerline Height	B Distance Between Bolt Holes		C	D	E	F Bolts	H	L	M	P	S	U	W	X	Approx. Weight
					Min	Max													
					4	1-7/16													
5	1-11/16	EP2B-111-T	EP2B-111-TE	2.13	6.13	6.38	7.80	2.76	2.06	1/2	1.25	4.25	2.58	0.91	0.75	1.84	2.11	0.23	6.37
6	1-15/16	EP2B-115-T	EP2B-115-TE	2.25	6.88	7.12	8.67	2.84	2.13	5/8	1.31	4.50	2.88	1.07	0.87	1.95	2.22	0.26	7.25
7	2-3/16	EP2B-203-T	EP2B-203-TE	2.50	7.64	7.88	9.61	2.99	2.56	5/8	1.50	4.99	3.25	0.99	0.88	2.06	2.33	0.26	10.29
8	2-7/16	EP2B-207-T	EP2B-207-TE	2.75	8.38	8.62	10.17	3.55	2.87	5/8	1.63	5.69	3.55	1.30	0.87	2.42	2.70	0.34	14.12
	2-1/2	EP2B-208-T	EP2B-208-TE																
9	2-11/16	EP2B-211-T	EP2B-211-TE	3.13	9.31	9.69	11.67	3.65	2.69	3/4	1.88	6.26	4.04	1.13	1.07	2.48	2.75	0.35	20.40
	2-15/16	EP2B-215-T	EP2B-215-TE																
10	3-7/16	EP2B-307-T	EP2B-307-TE	3.75	10.81	11.19	13.19	4.12	3.49	7/8	2.25	7.50	4.90	1.10	1.19	2.71	2.92	0.34	29.64
	3-1/2	EP2B-308-T	EP2B-308-TE																

Additional Notes

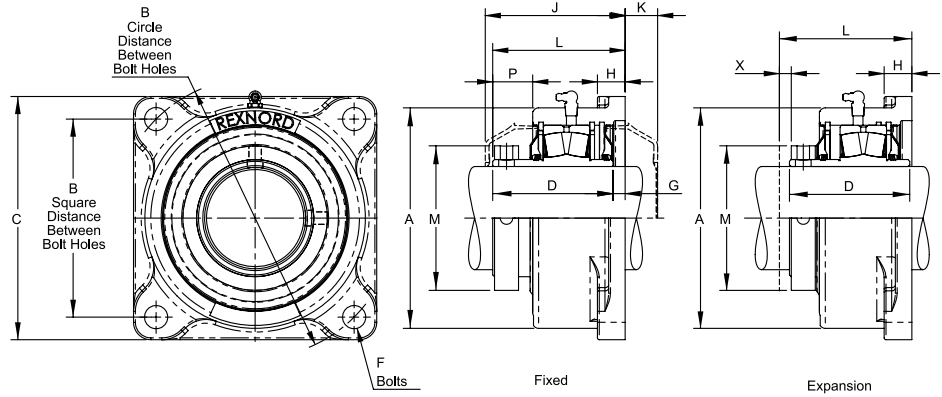
- Please call 1-866-REXNORD for availability
- Lubrication fitting tap size, 1/8" PT
- Bore size = nominal shaft size +.001 in/-.000 in (**+0.03 mm/-0.00 mm**)
- Base to centerline tolerance, +/- .005"
- Open and Closed End Caps available on all shaft sizes
- For Selection Guide, Load Ratings and Speed Limits see Rexnord PT Select Series Engineering section on pages 194 - 197.
- Note: Dimensions subject to change. Certified dimensions of ordered material furnished on request.

FB



Product Features

- Corrosion-resistant powder coating
- Cast iron housing
- Misalignment capabilities - total of 2°
- Triple lip seal standard; optional clearance seal
- Factory lubricated
- 90° grease fitting standard; straight fitting provided in box



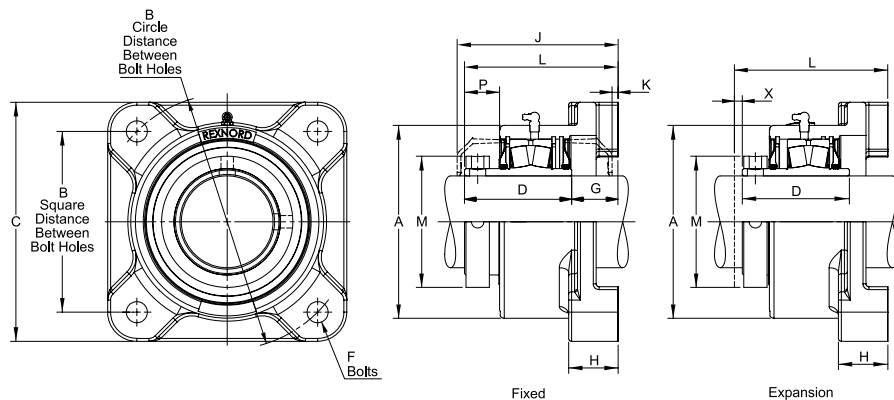
Bearing Dimensions

Size Code	Shaft Diameter	Fixed Part Number	Expansion Part Number	A	B Distance Between Bolt Holes		C	D	F Bolts	G	H	J	K	L Mounting Surface to Collar Face	M	P	X	Approx. Weight
					Square	Circle												
					4	1-7/16												
5	1-11/16	FB-111-T	FB-111-TE	4.00	3.89	5.50	5.13	2.76	1/2	0.25	0.53	3.28	0.93	3.01	2.58	1.00	0.22	5.66
6	1-15/16	FB-115-T	FB-115-TE	4.25	4.07	5.75	5.31	2.84	1/2	0.31	0.59	3.42	1.03	3.15	2.88	1.09	0.22	6.32
7	2-3/16	FB-203-T	FB-203-TE	4.60	4.51	6.38	5.89	2.99	5/8	0.28	0.56	3.55	1.12	3.27	3.25	1.15	0.26	7.64
8	2-7/16	FB-207-T	FB-207-TE	5.63	4.77	6.75	6.13	3.55	5/8	0.39	0.64	4.21	1.17	3.94	3.55	1.29	0.34	11.74
	2-1/2	FB-208-T	FB-208-TE															
9	2-11/16	FB-211-T	FB-211-TE	6.10	5.57	7.88	7.19	3.65	3/4	0.36	0.75	4.28	1.21	4.01	4.04	1.33	0.34	16.40
	2-15/16	FB-215-T	FB-215-TE															
10	3-7/16	FB-307-T	FB-307-TE	7.48	6.72	9.50	8.25	4.12	3/4	0.41	0.94	4.81	1.17	4.54	4.90	1.40	0.34	26.21
	3-1/2	FB-308-T	FB-308-TE															
11	3-15/16	FB-315-T	FB-315-TE	8.22	7.60	10.75	9.25	4.64	7/8	0.38	1.06	5.32	1.38	5.02	5.63	1.61	0.34	35.08

Additional Notes

- Please call 1-866-REXNORD for availability
- Lubrication fitting tap size, 1/8" PT
- Bore size = nominal shaft size +.001 in/-.000 in (**+0.03 mm/-0.00 mm**)
- Open and Closed End Caps available on all shaft sizes
- For Selection Guide, Load Ratings and Speed Limits see Rexnord PT Select Series Engineering section on pages 194 - 197.
- Note: Dimensions subject to change. Certified dimensions of ordered material furnished on request.

EFB



Product Features

- Type E Interchange
- Corrosion-resistant powder coating
- Cast iron housing
- Misalignment capabilities - total of 2°
- Triple lip seal standard; optional clearance seal
- Factory lubricated
- 90° grease fitting standard; straight fitting provided in box

Bearing Dimensions

Size Code	Shaft Diameter	Fixed	Expansion	A	B Distance Between Bolt Holes		C	D	F Bolts	G	H	J	K	L Mounting Surface to Collar Face	M	P	X	Approx. Weight
		Part Number	Part Number		Square	Circle												
		4	1-7/16		EFB-107-T	EFB-107-TE												
5	1-11/16	EFB-111-T	EFB-111-TE	4.00	4.12	5.83	5.37	2.76	1/2	0.72	1.19	3.75	0.46	3.48	2.58	1.00	0.22	6.83
6	1-15/16	EFB-115-T	EFB-115-TE	4.25	4.38	6.19	5.62	2.84	1/2	0.78	1.18	3.89	0.55	3.62	2.88	1.09	0.26	7.86
7	2-3/16	EFB-203-T	EFB-203-TE	4.60	4.87	6.89	6.25	2.99	5/8	0.93	1.38	4.20	0.46	3.93	3.25	1.15	0.26	9.75
8	2-7/16	EFB-207-T	EFB-207-TE	5.63	5.37	7.60	6.87	3.55	5/8	0.98	1.50	4.80	0.59	4.53	3.55	1.29	0.34	15.07
	2-1/2	EFB-208-T	EFB-208-TE															
9	2-11/16	EFB-211-T	EFB-211-TE	6.10	6.00	8.49	7.75	3.65	3/4	1.09	1.61	5.01	0.48	4.74	4.04	1.33	0.34	20.74
	2-15/16	EFB-215-T	EFB-215-TE															
10	3-7/16	EFB-307-T	EFB-307-TE	7.48	7.00	9.90	9.25	4.12	3/4	1.24	1.87	5.64	0.34	5.36	4.90	1.40	0.34	30.98
	3-1/2	EFB-308-T	EFB-308-TE															
11	3-15/16	EFB-315-T	EFB-315-TE	8.22	7.75	10.96	10.25	4.64	7/8	1.99	2.12	6.70	0.23	6.63	5.63	1.61	0.34	43.90

Additional Notes

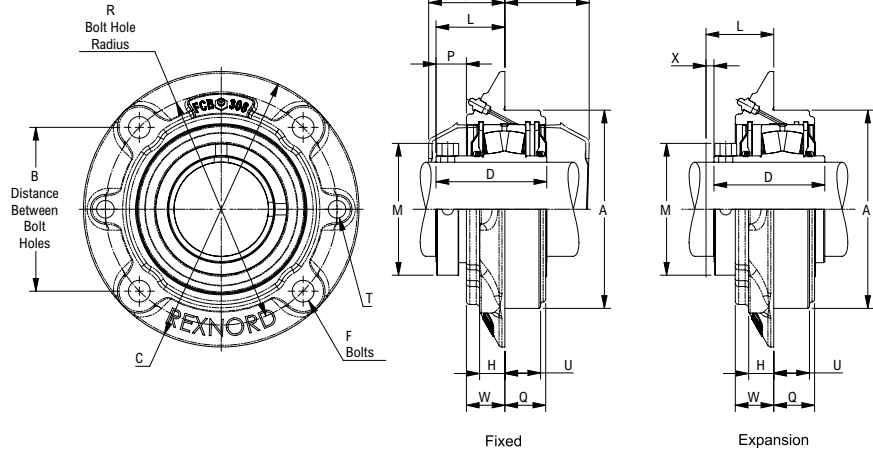
- Please call 1-866-REXNORD for availability
- Lubrication fitting tap size, 1/8" PT
- Bore size = nominal shaft size +.001 in/-.000 in (**+0.03 mm/-0.00 mm**)
- Open and Closed End Caps available on all shaft sizes
- For Selection Guide, Load Ratings and Speed Limits see Rexnord PT Select Series Engineering section on pages 194 - 197.
- Note: Dimensions subject to change. Certified dimensions of ordered material furnished on request.



Product Features

- Type E Interchange
- Corrosion-resistant powder coating
- Cast iron housing
- Misalignment capabilities - total of 2°
- Triple lip seal standard; optional clearance seal
- Factory lubricated
- Straight grease fitting standard

Reminder: Size 12 Has 6 Mounting Bolts!



Bearing Dimensions

Size Code	Shaft Diameter	Fixed	Expansion	A Pilot Diameter	B Distance Between Bolt Holes	C	D	F Bolts	H	J	K	L Mounting Surface to Collar Face	M	P	Q	R Bolt Circle Radius	T	U	W	X	Approx. Weight
		Part Number	Part Number																		
4-Bolt																					
4	1-7/16	FC-107-T	FC-107-TE	3.63	3.10	5.25	2.71	3/8	0.50	1.76	2.44	1.49	2.30	0.99	1.19	2.19	3/8-16	0.75	0.50	0.22	4.19
5	1-11/16	FC-111-T	FC-111-TE	4.25	3.62	6.13	2.76	7/16	0.50	1.79	2.43	1.52	2.58	0.91	1.25	2.56	7/16-14	0.88	0.61	0.23	6.15
6	1-15/16	FC-115-T	FC-115-TE	4.50	3.80	6.38	2.84	7/16	0.56	1.86	2.58	1.59	2.88	1.03	1.23	2.69	7/16-14	0.88	0.56	0.26	6.79
7	2-3/16	FC-203-T	FC-203-TE	5.00	4.24	7.13	2.99	1/2	0.56	1.88	2.78	1.61	3.25	0.95	1.42	3.00	1/2-13	1.00	0.66	0.26	9.16
8	2-7/16	FC-207-T	FC-207-TE	5.50	4.60	7.63	3.55	1/2	0.63	2.26	3.13	1.99	3.55	1.23	1.56	3.25	1/2-13	1.00	0.76	0.34	11.51
	2-1/2	FC-208-T	FC-208-TE																		
9	2-11/16	FC-211-T	FC-211-TE	6.38	5.30	8.75	3.65	5/8	0.75	2.36	3.13	2.09	4.04	1.09	1.63	3.75	5/8-11	1.25	1.00	0.34	17.69
	2-15/16	FC-215-T	FC-215-TE																		
10	3-7/16	FC-307-T	FC-307-TE	7.38	6.10	10.25	4.12	3/4	0.94	2.84	3.14	2.56	4.90	1.13	1.52	4.31	3/4-10	1.27	1.43	0.34	26.19
	3-1/2	FC-308-T	FC-308-TE																		
11	3-15/16	FC-315-T	FC-315-TE	8.13	6.63	10.88	4.64	3/4	1.13	3.19	3.51	2.89	5.63	1.46	1.75	4.69	3/4-10	1.47	1.43	0.34	33.50
6-Bolt																					
12	4-7/16	FC-407-T	FC-407-TE	10.25	5.88	13.58	5.14	3/4	1.00	3.58	3.54	3.28	6.19	1.39	1.85	5.88	3/4-10	1.45	1.89	0.34	57.64

Additional Notes

- Please call 1-866-REXNORD for availability
- Lubrication fitting tap size, 1/8" PT
- Bore size = nominal shaft size +.001 in/-.000 in (**+0.03 mm/-0.00 mm**)
- Pilot diameter tolerance, +.000 in/-.002 in (**+0.00 mm/-0.05 mm**)
- Bore tolerance for mounting, +.002 in/-.000 in (**+0.05 mm/-0.00 mm**)
- Open and Closed End Caps available on all shaft sizes
- For Selection Guide, Load Ratings and Speed Limits see Rexnord PT Select Series Engineering section on pages 194 - 197.
- Note: Dimensions subject to change. Certified dimensions of ordered material furnished on request.

Spherical Roller Bearings Split Housings: Link-Belt



Contents

	Page
Features and Benefits	206
Nomenclature	208
Engineering	210
Dimensions	
Pillow Blocks	224
Take-up Assemblies	241
Replacement Parts	243

Industries Served

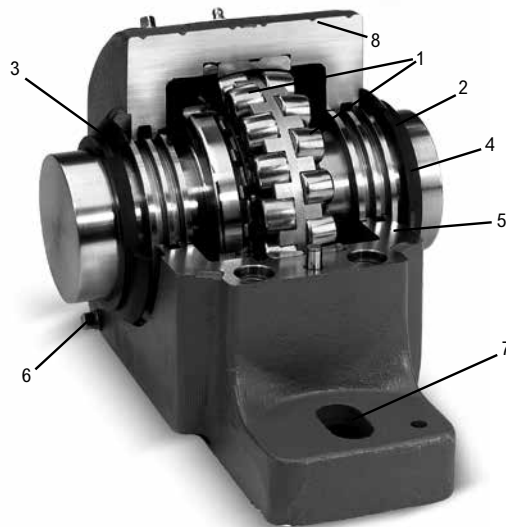
Mining
Forest Products
Aggregates
Steel
Air Handling
Construction
Package Handling
Wastewater Treatment



Series 6600, 6800, 6900, 7600, 7800, 7900, 22300, 22600 Spherical Roller Bearing

Self-aligning spherical roller bearing pillow blocks and take-ups provide high load carrying capacity for radial or combination radial and thrust loads.

They are designed for use on conveyors, dryers, road building equipment, runout tables, fans, crushers, hammermills and many other high-precision, heavy-duty applications.



1. Direct or Adapter Mounting

Spherical roller bearings may be direct or adapter mounted. Housings have provision for fixed or expansion mounting.

2. Choice of Seals

Type R multilabyrinth, D5 Pentac®, or Type D8 independently flushable seals — effectively retain lubricant and exclude contaminants.

3. Removable Housing Cap

Facilitates bearing mounting, inspection and maintenance.

4. Mating Surfaces are Machined

Caps and bases matched and marked.

5. Base and Cap are Dowelled for Accurate Assembly and Security

6. Oil or Grease Lubrication Ready

Large lubricant reservoir in base prolongs lubrication interval.

7. Slotted Bolt Holes

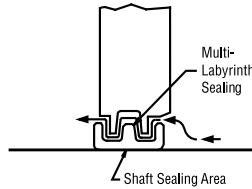
Slotted bolt holes in base facilitate mounting; machined finish on base for firm seating on supporting surface. Pry slots for easy cap removal.

8. Dimpled Flats for Bearing Monitor Probes

A Seal Choice for Every Environment

Metal Triple-Ring R Seal

This industry standard seal provides a labyrinth grease chamber between the housing grooves and the seal rings. Operates at high speed; good for moderate dust, dirt or moisture.

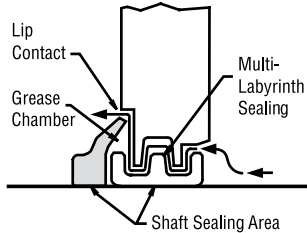
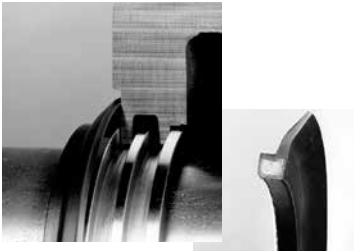


D5 Pentac 5-Point Sealing System

Rugged contact lip seal, molded on a Kevlar body, rotates with the shaft. The Pentac seal acts as a flinger, keeping debris away from the seal area, and provides five seal points.

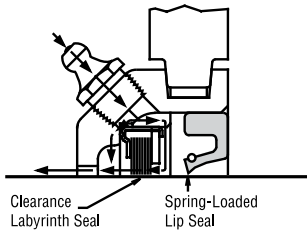
D5 Pentac 5-Point Sealing System

- 1 - Seals shaft
- 2 - Seals housing
- 3 - Creates a grease chamber to prevent bearing contamination
- 4 - Acts as a flinger
- 5 - Grease chambers created by multi-labyrinth chamber



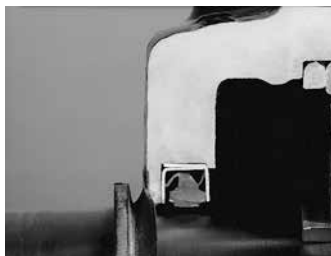
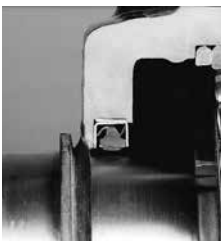
D8 Taconite Sealing System

A rugged cast carrier protects a metal labyrinth outboard seal and a spring-loaded inboard seal. When independently lubricated, the D8 system directs the grease between the two seals, purging all contaminants before they can reach the bearing chamber. Thousands are in use in the toughest applications worldwide.



Exclusive T Water Seal

Available on special order, this patented seal was developed for use on equipment which experiences constant water splash or frequent wash down. The unique T-shaped lip seal rides in a stainless steel carrier and rotates with the shaft. It seals the shaft and its one-way, double-contact lips allow for grease purge from the bearing chamber, but prevent the reverse flow of water or debris. The T seal is the standard in the environmental equipment industry. This bearing offers Pillow Blocks with special features for severe wash down environments. Black Rilsan Nylon 11 coated housings, stainless steel hardware and end caps or solid closed end housings, and the patented T contact water seal are the standard features of the BP-LB6800 series. Units may be further modified to meet specific needs.



Seal Comparison

	Triple Ring R Seal	Pentac D5 Seal	Taconite D8 Seal	Wash Down T Seal
Dirt/Dust	X	XX	XXX	X
Speed	XXX	XX	X	XX
Wash Downs	X	XX	XX	XXX
	x Good	xx Better	xxx Best	

Shaft	Part Number
1 7/16"	BP-LB6823
2 3/16"	BP-LB6835*
2 7/16"	BP-LB6839*
2 11/16"	BP-LB6843*
2 15/16"	BP-LB6847*
3 3/16"	BP-LB6851*
3 15/16"	BP-LB6863F
4 1/2"	BP-LB6872F
4 15/16"	BP-LB6879F

*For four-bolt base add suffix "F."

Unit with one side solid cast closed, add "C" suffix.

6600, 6800, 6900, 7600, 7800, 7900 Nomenclature

Symbol	Description	P	E	LB	79	65	F	B	C	-T2/	3
BP	Pillow block; two-piece; black Rilsan nylon II coated										
P	Pillow block; two-piece										
PK	Pillow block; two-piece cast steel housing (66, 68, 76 and 78 series)										
DS	Take-up, welded steel frame, hinged top										
E	Expansion Mounting										
LB	Spherical roller bearing										
66	Adapter mounted with 23000LBK bearing										
68	Adapter mounted with 22200LBK bearing										
69	Adapter mounted with 22300LBK bearing										
76	Direct shaft mounted with 23000LB bearing										
78	Direct shaft mounted with 22200LB bearing										
79	Direct shaft mounted with 22300LB bearing										
M	Metric bore adapter mount										
39	Shaft diameter in 16ths of an inch — adapter mounted										
65	Inner ring bore in millimeters — direct shaft mounted										
60	Shaft diameter in millimeters — adapter mounted										
F	Four-bolt base pillow block										
None	"T" Water seals										
D5	Pentac 5-point seals										
D8	Independently flushable seal										
B	Felt contact seal										
R	Multi-labyrinth seal										
C	Closed end unit										
T2	Locknut and washer included (76, 78, 79 series)										
2	Internal clearance less than C0										
0	Basic C0 internal clearance										
None	Internal clearance greater than C0 (standard)										
4	Internal clearance greater than C3										
12	Take-up adjustment, inches										

SAF22600, SAF22300 Nomenclature

Symbol	Description	F	SAF	S	E	226	17	C	T	215	4
F	Four-bolt base	_____									
SAF	Pillow block; two-piece; inch series; labyrinth seal		_____								
None	Gray Iron Cast Steel	_____	_____	_____	_____	_____	_____	_____	_____	_____	_____
S											
None	Fixed Unit — Furnish with spacer ring Expansion Unit	_____	_____	_____	_____	_____	_____	_____	_____	_____	_____
E											
223	Direct shaft mounted with 22300LB spherical roller bearing					_____					
226	Adapter mounted with 22300LBK spherical roller bearing					_____					
17	One-fifth bearing bore diameter in mm						_____				
C	Closed end unit							_____			
T	Lockwasher and locknut NOT INCLUDED (22300 Series)								_____		
None	Direct shaft mounted shaft size									_____	
215	Adapter mounted shaft size in inch and 1/16, i.e., 215 is 2 15/16 inch shaft size									_____	
2	Internal clearance less than C0										_____
0	Basic internal clearance										
None	Internal clearance greater than C0 (standard)										
4	Internal clearance greater than C3										

Large Bore Nomenclature

Symbol	Description	P	LB	222	44	K	C	71516
P	Pillow block; two-piece	_____						
PK	Pillow block; two-piece cast steel	_____						
LB	Spherical Roller Bearing		_____					
222	Direct shaft mounted with 22200LB bearing			_____				
223	Direct shaft mounted with 22300LB bearing			_____				
225	Adapter mounted with 22200LBK bearing			_____				
226	Adapter mounted with 22300LBK bearing			_____				
230	Adapter or direct shaft mounted with 23000 bearing			_____				
231	Adapter or direct shaft mounted with 23100 bearing			_____				
232	Adapter or direct shaft mounted with 23200 bearing			_____				
44	One-fifth bearing bore diameter in mm				_____			
K	Tapered bore bearing					_____		
C	End closure						_____	
71516	7 15/16" – shaft size							_____

Seal Rating Guide

Application Conditions	Seal Ratings			
	LER Clearance R	PenTac Sealing System D5	Taconite Sealing System D8	Water Seal T
Shaft Position				
Horizontal Shaft	4	4	4	4
Vertical Shaft	1	4	4	4
Operating Temperature				
Below -40°F	4	1	1	1
-40°F to 0°F	4	3	3	3
0°F to +250°F	4	4	4	4
+250°F to +400°F	4	0	0	0
Over 400°F	4	0	0	0
Speed				
Equal to / Less than limit in chart	4	4	4	4
More than limit in chart	4	1	1	1
Vibration/Shock				
Occasional - Mild	3	4	4	4
Occasional - Severe	2	4	4	4
Continuous - Mild	1	3	3	3
Continuous - Severe	0	3	3	3
Abrasive Material				
Coarse - Over #10 Mesh	4	4	4	4
Small - #10 to #50 Mesh	3	4	4	4
Fine - #50 to #200 Mesh	1	3	4	3
Very fine - Under #200 Mesh	0	2	4	2
"Caking or buildup" (cement, etc.)	2	3	4	3
Moisture				
Splash	2	3	4	4
Rain	2	3	4	4
Saturated Atmosphere	1	3	4	4
Flooding	0	1	3	4
Pressure Wash	0	1	4	4
Fibrous Material				
Short Fibers (lint, etc.)	1	4	4	4
Long Fibers (grass, etc.)	1	4	4	4
Chemical				
Acid Fumes and Liquids	1	1	1	1
Alkaline Fumes and Liquids	1	1	1	1

Rating Code

4 - Excellent - Best seal for conditions listed.

3 - Good - Sealability is above average.

2 - Fair - Seal performs under intermittent conditions.

1 - Limited - Actual conditions must be known to evaluate sealability. Check "General Characteristic Guide" for construction as well as benefits and limitations for further evaluation.

0 - Not acceptable - Will not effectively perform seal functions. Contact Rexnord for special assistance in the realm of materials and designs.

Series 6600, 6800, 6900, 7600, 7800, 7900, 23000, 23100 and 23200 Selection Guide

To select a pillow block, determine the applied radial load, the applied thrust load, the desired Rating Life, the required minimum shaft size, and applicable operating conditions. The procedure shown here will aid in selecting a pillow block to meet an L_{10} design life. The formulas for calculating life expectancy should be used to determine the Rating Life L_{10} for the pillow block selected. Spherical roller bearing pillow blocks are available in Series 6600, 6800, 6900, 7600, 7800, 7900, 23000, 23100 and 23200. Because a number of series are available, several different pillow blocks that will fulfill and L_{10} life requirement can often be chosen.

Some of the factors to consider when choosing between series are: cost, speed limit, minimum shaft diameter, thrust load, space limitations, and type of shaft mounting.

The selection procedures and rating formulas shown here are in agreement with The American Bearing Manufacturers Association Standards and ANSI/ ABMA Standards STD 11-1990. Ratings are based on fatigue life.

The Rating Life L_{10} or fatigue life at 90% reliability is the usual basis for bearing selection.

For radial load applications only, Table 3 can be used to select a unit or to determine L_{10} life expectancy.

To assure a satisfactory bearing application, fitting practice, mounting, lubrication, sealing, static rating, housing strength, operating conditions and maintenance must be considered.

Steps for Selection

Step 1

Determine an appropriate L_{10} design life.

	Operating time, hours per year	Design life, years	L_{10} design life, hours
Heavy seasonal usage	1,400 to 1,600	4-6	8,000
Industrial—8 hour shift	2,000	10	20,000
Industrial—16 hour shift	4,000	10	40,000
Industrial—continuous	8,700	10	80,000 to 100,000
Industrial—High reliability	—	—	120,000 to 300,000

Step 2

Determine a required $\left(\frac{C}{P}\right)$ from Table 1.

Step 3

Calculate the required C and select a roller bearing pillow block.

a For radial load only: $P = F_r$

Required $C = \left(\frac{C}{P}\right) P$ using $\left(\frac{C}{P}\right)$ from Step 2

Select a roller bearing pillow block from Table 2 or Table 4 having a basic load rating C equal to or greater than the required C.

b For combined radial and thrust loads:

Select a roller bearing pillow block of the desired shaft size from Table 2 or Table 4 Calculate the ratio of thrust load F_a to the radial load F_r .

$$\frac{F_a}{F_r}$$

Calculate the equivalent radial load P

$$P = X F_r + Y F_a$$

If $\frac{F_a}{F_r}$ is equal to or less than e, then $P = X_1 F_r + Y_1 F_a$

If $\frac{F_a}{F_r}$ is greater than e, then $P = X_2 F_r + Y_2 F_a$

For values of e, X_1 , Y_1 , X_2 , and Y_2 , see Table 2 or Table 4

Required $C = \left(\frac{C}{P}\right) P$ using $\left(\frac{C}{P}\right)$ from Step 2

Consult the bearing rating Table 2 or Table 4, to see if the selected bearing meets or exceeds the required C. The life expectancy of other sizes and series of bearings can be calculated similarly.

Selection

Symbols for formulas:

C = basic load rating, pounds (or newtons)	L ₁₀ = rating life, hours
Co = static load rating, pounds (or newtons)	n = speed, revolutions per minute
e = a reference value	P = equivalent radial load, pounds (or newtons)
F _a = thrust load, pounds (or newtons)	X = radial factor
Fr = radial load, pounds (or newtons)	Y = thrust factor

Table 1 • Relation of L₁₀ life and speed to $\left(\frac{C}{P}\right)$

Bearing Life Hours L ₁₀	Speed, n									
	50	100	200	300	400	500	600	700	800	
3000	1.93	2.38	2.93	3.31	3.61	3.86	4.07	4.27	4.44	
4000	2.11	2.59	3.19	3.61	3.93	4.20	4.44	4.65	4.84	
5000	2.25	2.77	3.42	3.86	4.20	4.50	4.75	4.97	5.18	
6000	2.38	2.93	3.61	4.07	4.44	4.75	5.02	5.25	5.47	
8000	2.59	3.19	3.93	4.44	4.84	5.18	5.47	5.73	5.96	
10000	2.77	3.42	4.20	4.75	5.18	5.54	5.85	6.12	6.37	
12000	2.93	3.61	4.44	5.02	5.47	5.85	6.18	6.47	6.73	
14000	3.07	3.78	4.65	5.25	5.73	6.12	6.47	6.77	7.05	
16000	3.19	3.93	4.84	5.47	5.96	6.37	6.73	7.05	7.34	
18000	3.31	4.07	5.02	5.66	6.18	6.60	6.97	7.30	7.60	
20000	3.42	4.20	5.18	5.85	6.37	6.81	7.20	7.54	7.85	
25000	3.65	4.50	5.54	6.25	6.81	7.29	7.70	8.06	8.39	
30000	3.86	4.75	5.85	6.60	7.20	7.70	8.13	8.51	8.86	
35000	4.04	4.97	6.12	6.92	7.54	8.06	8.51	8.92	9.28	
40000	4.20	5.18	6.37	7.20	7.85	8.39	8.86	9.28	9.66	
45000	4.36	5.36	6.60	7.46	8.13	8.69	9.18	9.61	10.00	
50000	4.50	5.54	6.81	7.70	8.39	8.97	9.48	9.92	10.30	
60000	4.75	5.85	7.20	8.13	8.86	9.48	10.00	10.50	10.90	
70000	4.97	6.12	7.54	8.51	9.28	9.92	10.50	11.00	11.40	
80000	5.18	6.37	7.85	8.86	9.66	10.30	10.90	11.40	11.90	
90000	5.36	6.60	8.13	9.18	10.00	10.70	11.30	11.80	12.30	
100000	5.54	6.81	8.39	9.48	10.30	11.00	11.70	12.20	12.70	
150000	6.25	7.70	9.48	10.70	11.70	12.50	13.20	13.80	14.40	
200000	6.81	8.39	10.30	11.70	12.70	13.60	14.40	15.00	15.70	

	Speed, n									
	900	1000	1200	1500	1800	2400	3000	3600	6000	
3000	4.60	4.75	5.02	5.36	5.66	6.18	6.60	6.97	8.13	
4000	5.02	5.18	5.47	5.85	6.18	6.73	7.20	7.60	8.86	
5000	5.36	5.54	5.85	6.25	6.60	7.20	7.70	8.13	9.48	
6000	5.66	5.85	6.18	6.60	6.97	7.60	8.13	8.59	10.00	
8000	6.18	6.37	6.73	7.20	7.60	8.29	8.86	9.36	10.90	
10000	6.60	6.81	7.20	7.70	8.13	8.86	9.48	10.00	11.70	
12000	6.97	7.20	7.60	8.13	8.59	9.36	10.00	10.60	12.30	
14000	7.30	7.54	7.96	8.51	8.99	9.80	10.50	11.10	12.90	
16000	7.60	7.85	8.29	8.86	9.36	10.20	10.90	11.50	13.40	
18000	7.88	8.13	8.59	9.18	9.70	10.60	11.30	11.90	13.90	
20000	8.13	8.39	8.86	9.48	10.00	10.90	11.70	12.30	14.40	
25000	8.69	8.97	9.48	10.10	10.70	11.70	12.50	13.20	15.40	
30000	9.18	9.48	10.00	10.70	11.30	12.30	13.20	13.90	16.20	
35000	9.61	9.92	10.50	11.20	11.80	12.90	13.80	14.60	17.00	
40000	10.00	10.30	10.90	11.70	12.30	13.40	14.40	15.20	17.70	
45000	10.40	10.70	11.30	12.10	12.80	13.90	14.90	15.70	18.30	
50000	10.70	11.00	11.70	12.50	13.20	14.40	15.40	16.20	18.90	
60000	11.30	11.70	12.30	13.20	13.90	15.20	16.20	17.10	20.00	
70000	11.80	12.20	12.90	13.80	14.60	15.90	17.00	17.90	20.90	
80000	12.30	12.70	13.40	14.40	15.20	16.50	17.70	18.70	21.80	
90000	12.80	13.20	13.90	14.90	15.70	17.10	18.30	19.40	22.60	
100000	13.20	13.60	14.40	15.40	16.20	17.70	18.90	20.00	23.30	
150000	14.90	15.40	16.20	17.30	18.30	20.00	21.40	22.60	26.30	
200000	16.20	16.70	17.70	18.90	20.00	21.80	23.30	24.60	28.70	

Basic Formula

$$\left(\frac{C}{P}\right) = \left(\frac{L_{10} \times n \times 60}{1,000,000}\right)^{3/10}$$

$$L_{10} = \frac{\left(\frac{C}{P}\right)^{10/3} \times 1,000,000}{n \times 60}$$

Life Expectancy

To calculate the Rating Life L₁₀ of any selected or trial bearing:

Step 1

Determine the equivalent radial load P.

a For radial load only:

$$P = F_r$$

b For combined radial and thrust load:

$$P = X F_r + Y F_a$$

if $\frac{F_a}{F_r}$ is equal to or less than e, then

$$P = X_1 F_r + Y_1 F_a$$

if $\frac{F_a}{F_r}$ is greater than e, then

$$P = X_2 F_r + Y_2 F_a$$

For values of e, X₁, Y₁, X₂, and Y₂, consult the appropriate bearing rating Table 2 Table 4.

Step 2

Calculate the ratio of the basic load rating C to the equivalent radial load.

$$\left(\frac{C}{P}\right)$$

Step 3

Approximate the bearing life from Table 1.

Live Adjustment

The Rating Life, L₁₀, may be modified for some applications in accordance with the formula

$$L_n = a_1 a_2 a_3 L_{10}$$

where L_n = Adjusted life for (100-n) % reliability,

a₁ = Life adjustment factor for reliability

a₂ = Life adjustment factor

for material and processing

a₃ = Life adjustment factor for operating conditions.

For most normal applications, all factors will be taken as 1, and the Rating Life used as the selection basis or life estimate. In addition, as long as standard catalog bearings are used, a₂ will be normally set equal to one.

The factor a₃ covers such things as lubrication, misalignment, and temperature. Some conditions that could yield a₃ significantly different than unity include speeds less than 20000 DN or greater than 200000 DN, temperatures below -40°F (-40°C) or above 275°F (135°C). For other possible conditions, as well as additional information on life adjustment factors, consult Rexnord Bearing Division.

Table 2 • 6600, 6800, 7600, 7800 Series Load Ratings and Speed Limits

Basic Bearing Number				Bearing Size Number	Co Static Load Rating pounds/ newtons	C Basic Load Rating pounds/ newtons	Approximate Speed Limit RPM*			e	Fa — ≤ e Fr		Fa — > e Fr	
Adapter Mounted		Direct Shaft Mounted					Oil	Grease	D5 Seal 1mm Push-in#		X1	Y1	X2	Y2
Shaft Diameter inches/mm	Number	Bearing Seat mm	Number											
1 7/16	LB6823	22209LB	23600	20800	6200	5300	5300	0.26	1.00	2.6	0.67	3.9
1 1/2	LB6824													
40	LB68M40				105000	92500								
1 11/16	LB6827	22210LB	25500	22000	5500	5000	5000	0.26	1.00	2.8	0.67	4.2
1 3/4	LB6828													
45	LB68M45				113000	97900								
1 15/16	LB6831	22211LB	32500	27000	5000	4500	4500	0.23	1.00	2.9	0.67	4.4
2	LB6832													
50	LB68M50				145000	120000								
2 3/16	LB6835	22213LB	46500	38000	4300	3800	3800	0.24	1.00	2.8	0.67	4.2
60	LB68M60				207000	169000								
2 7/16	LB6839	75	LB7875	22215LB	53000	41500	3700	3400	3400	0.22	1.00	3.1	0.67	4.6
65	LB68M65				236000	185000								
2 11/16	LB6843	80	LB7880	22216LB	58500	46500	3500	3200	3200	0.22	1.00	3.1	0.67	4.7
70	LB68M70				260000	207000								
2 15/16	LB6847	85	LB7885	22217LB	73500	58500	3250	3000	3000	0.22	1.00	3.0	0.67	4.5
3	LB6848													
75	LB68M75				327000	260000								
3 3/16	LB6851	90	LB7890	22218LB	81500	64000	3000	2600	2600	0.23	1.00	2.9	0.67	4.3
80	LB68M80				363000	285000								
3 7/16	LB6855	100	LB78100	22220LB	104000	80000	2800	2200	2200	0.24	1.00	2.8	0.67	4.2
3 1/2	LB6856													
90	LB68M90				463000	356000								
3 11/16	LB6859	110	LB78110	22222LB	132000	102000	2500	2000	2000	0.25	1.00	2.7	0.67	4.0
3 15/16	LB6863													
4	LB6864				587000	454000								
100	LB68M100													
4 3/16	LB6867	120	LB78120	22224LB	163000	120000	2300	1900	1900	0.25	1.00	2.7	0.67	4.0
110	LB68M110				725000	534000								
4 7/16	LB6871	130	LB78130	22226LB	196000	143000	2100	1800	1800	0.26	1.00	2.6	0.67	3.9
4 1/2	LB6872													
115	LB68M115				872000	636000								
4 15/16	LB6879	140	LB78140	22228LB	228000	166000	1950	1700	1700	0.25	1.00	2.7	0.67	4.0
5	LB6880													
125	LB68M125				1010000	738000								

Table 2 • 6600, 6800, 7600, 7800 Series Load Ratings and Speed Limits (continued)

Basic Bearing Number				Bearing Size Number	Co Static Load Rating pounds/ newtons	C Basic Load Rating pounds/ newtons	Approximate Speed Limit RPM*			e	Fa — ≤ e Fr		Fa — > e Fr	
Adapter Mounted		Direct Shaft Mounted					Oil	Grease	D5 Seal 1mm Push-in#		X1	Y1	X2	Y2
Shaft Diameter inches/mm	Number	Bearing Seat mm	Number											
5 3/16 135	LB6883 LB68M135	150	LB78150	22230LB	270000 1200000	190000 845000	1850	1600	1600	0.25	1.00	2.7	0.67	4.0
5 7/16 140	LB6887 LB68M140	160	LB78160	22232LB	310000 1380000	216000 961000	1700	1500	1500	0.26	1.00	2.6	0.67	3.9
5 15/16 6 150	LB6895 LB6896 LB68M150	170	LB78170	22234LB	345000 1530000	250000 1110000	1600	1300	1300	0.26	1.00	2.6	0.67	3.9
6 7/16 6 1/2 160	LB68103 LB68104 LB68M160	180	LB78180	22236LB	365000 1620000	255000 1130000	1500	1300	1300	0.25	1.00	2.7	0.67	4.0
6 15/16 7 170	LB68111 LB68112 LB68M170	190	LB78190	22238LB	415000 1850000	270000 1200000	1400	1200	1200	0.28	1.00	2.4	0.67	3.6
7 3/16 180	LB68115 LB68M180	200	LB78200	22240LB	450000 2000000	300000 1330000	1300	1100	1100	0.29	1.00	2.3	0.67	3.5
7 1/2 7 15/16 8 200	LB68120 LB68127 LB68128 LB68M200	220	LB78220	22244LB	550000 2450000	365000 1620000	1200	1000	1000	0.29	1.00	2.3	0.67	3.5
8 7/16 8 15/16	LB22548K8716 LB22548K81516	240	LB22248	22248LB	650000 2890000	420500 1870000	950	750	N/A	0.27	1.00	2.5	0.67	3.7
8 7/16 8 1/2 8 15/16 9 220	LB66135 LB66136 LB66143 LB66144 LB66M220	240	LB76240	23048LB	490000 2180000	260000 1160000	1100	1000	1000	0.25	1.00	2.7	0.67	4.1
9 7/16 9 1/2 9 15/16 10 10 7/16 10 1/2 260	LB66B151 LB66B152 LB66159 LB66160 LB66167 LB66168 LB66M260	280	LB76280	23056LB	670000 2980000	345000 1530000	950	850	850	0.25	1.00	2.7	0.67	4.1

* Speed limits are based on the following:

1. Type R seals properly aligned.
 - a. For the type B seals, limit is 800 surface feet per minute (4.0 m/s) with good alignment.
 - b. For type D8 seals, limit is 1500 surface feet per minute (7.6 m/s) with good alignment.
2. Proper operating internal clearance.
3. Adequate lubrication and maintenance (special lubricants and/or more frequent relubrication may be required).
4. Normal room temperature environment and no extraneous heat sources, such that bearing operating temperature does not exceed 100°C (212°F).
5. Equivalent radial load not greater than 7% of C.
6. Axial load, if any, not greater than 20% of radial load.

D5 Pentac speed limits in the chart are based on pushing the Pentac seal against the housing face a distance of 1 mm as specified by the service instructions. The Pentac seal can be pressed in a distance of 2 mm for high contaminant environments. The speed limit at a 2 mm "Push-In" distance should be limited to 80% of those listed in the chart.

Table 3 • Radial Load Ratings in Pounds at Various RPM for Appropriate L₁₀ Life Hours

Basic Unit Number		L ₁₀ Minimum Life, hours	Radial Load Ratings, Pounds																	
Adapter Mounted	Direct Shaft Mounted		Speed, RPM																	
			50	100	200	300	400	500	600	700	800	900	1000	1200	1500	1800	2000	2500	3000	3500
LB6823		8000	8017	6512	5289	4683	4296	4018	3804	3632	3490	3368	3264	3090	2890	2736	2651	2479	2347	2241
LB6824		20000	6090	4947	4018	3558	3264	3052	2890	2759	2651	2559	2479	2347	2195	2078	2014	1883	1783	1703
LB68M40		40000	4947	4018	3264	2890	2651	2479	2347	2241	2153	2078	2014	1907	1783	1688	1636	1530	1448	1383
		100000	3758	3052	2479	2195	2014	1883	1783	1703	1636	1579	1530	1448	1355	1282	1243	1162	1100	1051
LB6827		8000	8479	6887	5594	4954	4544	4250	4024	3842	3691	3563	3452	3268	3056	2894	2804	2622	2483	2370
LB6828		20000	6441	5232	4250	3763	3452	3228	3056	2918	2804	2706	2622	2483	2322	2198	2130	1992	1886	1801
LB68M45		40000	5232	4250	3452	3056	2804	2622	2483	2370	2277	2198	2130	2017	1886	1786	1730	1618	1532	1463
		100000	3975	3228	2622	2322	2130	1992	1886	1801	1730	1670	1618	1532	1433	1356	1314	1229	1164	1111
LB6831		8000	10406	8453	6866	6079	5577	5216	4938	4715	4530	4372	4236	4011	3751	3551	3441	3218	3047	2909
LB6832		20000	7905	6421	5216	4618	4236	3962	3751	3582	3441	3322	3218	3047	2850	2698	2614	2445	2315	2210
LB68M50		40000	6421	5216	4236	3751	3441	3218	3047	2909	2795	2698	2614	2475	2315	2191	2123	1986	1880	1795
		100000	4878	3962	3218	2850	2614	2445	2315	2210	2123	2049	1986	1880	1758	1665	1613	1508	1428	1364
LB6835		8000	14646	11896	9663	8556	7849	7340	6950	6636	6375	6154	5962	5645	5279	4998	4843	4529	4288	4094
LB68M60		20000	11126	9037	7340	6500	5962	5576	5279	5041	4843	4675	4529	4288	4011	3797	3679	3441	3258	3110
		40000	9037	7340	5962	5279	4843	4529	4288	4094	3934	3797	3679	3483	3258	3084	2988	2795	2646	2526
		100000	6865	5576	4529	4011	3679	3441	3258	3110	2988	2884	2795	2646	2475	2343	2270	2123	2010	1919
LB6839	LB7875	8000	15995	12992	10553	9344	8572	8016	7590	7247	6962	6721	6511	6165	5766	5459	5289	4946	4683	4472
LB68M65		20000	12151	9869	8016	7098	6511	6090	5766	5505	5289	5105	4946	4683	4380	4147	4018	3758	3558	3397
		40000	9869	8016	6511	5766	5289	4946	4683	4472	4296	4147	4018	3804	3558	3368	3263	3052	2890	2759
		100000	7497	6090	4946	4380	4018	3758	3558	3397	3263	3150	3052	2890	2703	2559	2479	2319	2195	2096
LB6843	LB7880	8000	17922	14557	11824	10470	9604	8982	8504	8120	7801	7530	7296	6908	6460	6116	5926	5542	5247	5010
LB68M70		20000	13615	11059	8982	7954	7296	6824	6460	6168	5926	5720	5542	5247	4908	4646	4502	4210	3986	3806
		40000	11059	8982	7296	6460	5926	5542	5247	5010	4814	4646	4502	4262	3986	3774	3657	3420	3238	3091
		100000	8401	6824	5542	4908	4502	4210	3986	3806	3657	3530	3420	3238	3028	2867	2778	2598	2460	2348
LB6847	LB7885	8000	22547	18314	14876	13172	12083	11300	10699	10215	9814	9474	9179	8690	8127	7695	7455	6973	6602	6303
LB6848		20000	17128	13912	11300	10006	9179	8584	8127	7760	7455	7197	6973	6602	6174	5845	5664	5297	5015	4788
LB68M75		40000	13912	11300	9179	8127	7455	6973	6602	6303	6056	5845	5664	5362	5015	4748	4600	4302	4073	3889
		100000	10569	8584	6973	6174	5664	5297	5015	4788	4600	4441	4302	4073	3810	3607	3495	3268	3094	2955
LB6851	LB7890	8000	24667	20036	16274	14410	13219	12363	11705	11176	10737	10364	10042	9507	8892	8418	8156	7628	7222	6896
LB68M80		20000	18738	15220	12363	10947	10042	9391	8892	8490	8156	7873	7628	7222	6755	6395	6196	5795	5486	5238
		40000	15220	12363	10042	8892	8156	7628	7222	6896	6625	6395	6196	5866	5486	5194	5033	4707	4456	4255
		100000	11562	9391	7628	6755	6196	5795	5486	5238	5033	4858	4707	4456	4168	3946	3823	3576	3385	3232
LB6855	LB78100	8000	30834	25045	20343	18013	16523	15453	14631	13970	13421	12955	12552	11884	11115	10523	10196	9535	9028	8620
LB6856		20000	23423	19025	15453	13684	12552	11739	11115	10612	10196	9842	9535	9028	8443	7994	7745	7244		
LB68M90		40000	19025	15453	12552	11115	10196	9535	9028	8620	8281	7994	7745	7333	6858	6493	6291	5884		
		100000	14453	11739	9535	8443	7745	7244	6858	6548	6291	6073	5884	5570	5210	4932	4779	4470		
LB6859	LB78110	8000	39313	31932	25937	22966	21067	19703	18654	17811	17112	16518	16004	15152	14171	13417	12999	12158		
LB6863		20000	29864	24257	19703	17447	16004	14968	14171	13531	12999	12548	12158	11510	10765	10192	9875	9349	8744	
LB6864		40000	24257	19703	16004	14171	12999	12158	11510	10990	10559	10192	9875	9349	8744	8279	8021	7502		
LB68M100		100000	18427	14968	12158	10765	9875	9236	8744	8349	8021	7743	7502	7102	6642	6289	6093	5699		
LB6867	LB78120	8000	46251	37567	30514	27019	24785	23180	21946	20955	20132	19433	18828	17826	16672	15784	15293			
LB68M110		20000	35135	28538	23180	20525	18828	17609	16672	15918	15293	14762	14303	13542	12665	11991	11618			
		40000	28538	23180	18828	16672	15293	14303	13542	12930	12422	11991	11618	10999	10287	9739	9436			
		100000	21679	17609	14303	12665	11618	10865	10287	9822	9436	9109	8825	8356	7815	7399	7168			
LB6871	LB78130	8000	55115	44768	36363	32198	29536	27623	26153	24971	23990	23157	22437	21243	19867	18810	18224			
LB6872		20000	41869	34008	27623	24459	22437	20984	19867	18969	18224	17592	17044	16137	15092	14289	13844			
LB68M115		40000	34008	27623	22437	19867	18224	17044	16137	15408	14803	14289	13844	13107	12259	11606	11245			
		100000	25834	20984	17044	15092	13844	12948	12259	11705	11245	10855	10517	9957	9312	8817	8542			
LB6879	LB78140	8000	63980	51968	42211	37377	34286	32066	30359	28987	27849	26882	26046	24659	23063	21835				
LB6880		20000	48603	39478	32066	28393	26046	24359	23063	22020	21156	20421	19786	18733	17520	16587				
LB68M125		40000	39478	32066	26046	23063	21156	19786	18733	17886	17184	16587	16071	15216	14230	13473				
		100000	29990	24359	19786	17520	16071	15030	14230	13587	13054	12601	12209	11559	10810	10235				
LB6883	LB78150	8000	73230	59481	48314	42780	39243	36702	34748	33178	31875	30769	29811	28225	26397	24992				
LB68M135		20000	55630	45186	36702	32498	29811	27881	26397	25204	24214	23374	22646	21441	20053	18985				
		40000	45186	36702	29811	26397	24214	22646	21441	20472	19668	18985	18395	17415	16288	15421				
		100000	34326	27881	22646	20053	18395	17204	16288	15552	14941	14422	13974	13230	12373	11715				
LB6887	LB78160	8000	83251	67621	54925	48635	44613	41724	39504	37718	36237	34979	33891	32087	30009					
LB68M140		20000	63242	51369	41724	36946	33891	31696	30009	28653	27528	26572	25745	24375	22797					
		40000	51369	41724	33891	30009	27528	25745	24375	23273	22360	21583	20912	19799	18517					
		100000	39023	31696	25745	22797	20912	19558	18517	17680	16986	16396	15886	15040	14066					
LB6895	LB78170	8000	96356	78265	63571	56290	51636	48292	45722	43655	41941	40485	39225	37138	34733					
LB6896		20000	73197	59455	48292	42761	39225	36686	34733	33163	31861	30755	29798	28212	26385					
LB68M150		40000	59455	48292	39225	34733	31861	29798	28212	26937	25879	24981	2							

Table 4 • Series 6900, 7900, SAF22600, SAF22300 Load Ratings and Speed Limits

Basic Bearing Number				Bearing Size Number	Co Static Load Rating	C Basic Load Rating	Approximate Speed Limit RPM*		e	$\frac{F_a}{F_r} \leq e$		$\frac{F_a}{F_r} > e$	
Adapter Mounted		Direct Shaft Mounted					Oil	Grease		X1	Y1	X2	Y2
Shaft Diameter	Number	Bearing Seat mm	Number										
inches					pounds/newtons	pounds/newtons							
1 7/16	LB6923	45	LB7945	22309LB	40000	35500	4800	3800	0.36	1.00	1.9	0.67	2.8
1 1/2	LB6924				178000	158000							
1 11/16	LB6927	50	LB7950	22310LB	48000	42500	4300	3400	0.36	1.00	1.9	0.67	2.8
					214000	189000							
1 15/16	LB6931	55	LB7955	22311LB	57000	50000	4000	3200	0.36	1.00	1.9	0.67	2.8
2	LB6932				254000	222000							
2 3/16	LB6935	65	LB7965	22313LB	80000	65500	3400	2600	0.34	1.00	2.0	0.67	3.0
					356000	291000							
2 7/16	LB6939	75	LB7975	22315LB	98000	83000	3000	2200	0.34	1.00	2.0	0.67	3.0
2 1/2	LB6940				436000	369000							
2 11/16	LB6943	80	LB7980	22316LB	112000	93000	2800	2000	0.34	1.00	2.0	0.67	3.0
					498000	414000							
2 15/16	LB6947	85	LB7985	22317LB	122000	102000	2600	1900	0.33	1.00	2.0	0.67	3.0
					543000	454000							
3 3/16	22618-303	90	22318	22318LB	140000	114000	2400	1800	0.33	1.00	2.0	0.67	3.0
					623000	507000							
3 7/16	22620-307	100	22320	22320LB	183000	146000	2200	1700	0.34	1.00	2.0	0.67	3.0
3 1/2	22620-308				814000	649000							
3 15/16	22622-315	110	22322	22322LB	236000	180000	2000	1600	0.33	1.00	2.1	0.67	3.1
4	22622-400				1050000	801000							
4 3/16	22624-403	120	22324	22324LB	260000	204000	1800	1400	0.33	1.00	2.1	0.67	3.1
					1160000	907000							
4 7/16	22626-407	130	22326	22326LB	305000	236000	1700	1300	0.33	1.00	2.1	0.67	3.1
					1360000	1050000							
4 15/16	22628-415	140	22328	22328LB	360000	275000	1500	1100	0.34	1.00	2.0	0.67	3.0
5	22628-500				1600000	1220000							
5 3/16	22630-503	150	22330	22330LB	405000	310000	1400	1000	0.33	1.00	2.0	0.67	3.0
					1800000	1380000							
5 7/16	22632-507	160	22332	22332LB	425000	325000	1300	950	0.37	1.00	1.8	0.67	2.7
					1890000	1450000							
5 15/16	22634-515	170	22334	22334LB	475000	360000	1300	950	0.37	1.00	1.8	0.67	2.7
					2110000	1600000							

If the load P is greater than .25C, consult Rexnord Bearing Division.

*Speed limits are based on the following:

1. Negligible seal torque (e.g., non-contact seals)
2. Proper operating internal clearance.
3. Adequate lubrication and maintenance (special lubricants and/or more frequent relubrication may be required).
4. Normal room temperature environment and no extraneous heat sources, such that bearing operating temperature does not exceed 100°C (212°F).
5. Equivalent radial load not greater than 7% of C.
6. Axial load, if any, not greater than 20% of radial load.

Table 5 • Radial Load Ratings in Pounds at Various RPM for Appropriate L₁₀ Life Hours

Basic Unit Number		L ₁₀ Minimum Life, hours	Radial Load Ratings, Pounds																	
Adapter Mounted	Direct Shaft Mounted		Speed, RPM																	
			50	100	200	300	400	500	600	700	800	900	1000	1200	1500	1800	2000	2500	3000	3500
LB6923 LB6924	LB7945	8000	13682	11114	9027	7993	7332	6857	6492	6199	5956	5749	5570	5274	4932	4670	4524	4231	4006	3825
		20000	10394	8443	6857	6072	5570	5209	4932	4709	4524	4367	4231	4006	3747	3547	3437	3214	3043	2906
		40000	8443	6857	5570	4932	4524	4231	4006	3825	3675	3547	3437	3254	3043	2881	2792	2611	2472	2360
		100000	6413	5209	4231	3747	3437	3214	3043	2906	2792	2695	2611	2472	2312	2189	2121	1983	1878	1793
LB6927	LB7950	8000	16380	13305	10807	9569	8778	8210	7773	7421	7130	6882	6668	6313	5905	5590	5416	5066	4796	4579
		20000	12444	10107	8210	7269	6668	6237	5905	5638	5416	5228	5066	4796	4485	4247	4115	3848	3643	3479
		40000	10107	8210	6668	5905	5416	5066	4796	4579	4399	4247	4115	3896	3643	3449	3342	3126	2959	2826
		100000	7678	6237	5066	4485	4115	3848	3643	3479	3342	3226	3126	2959	2768	2620	2539	2374	2248	2146
LB6931 LB6932	LB7955	8000	19271	15653	12714	11258	10327	9658	9144	8731	8388	8097	7845	7428	6947	6577	6372	5960	5642	5387
		20000	14639	11891	9658	8552	7845	7337	6947	6633	6372	6151	5960	5642	5277	4996	4841	4527	4286	4093
		40000	11891	9658	7845	6947	6372	5960	5642	5387	5176	4996	4841	4583	4286	4058	3932	3677	3482	3324
		100000	9033	7337	5960	5277	4841	4527	4286	4093	3932	3795	3677	3482	3256	3083	2987	2793	2645	2525
LB6935	LB7965	8000	25245	20505	16656	14748	13529	12653	11979	11438	10989	10607	10277	9730	9100	8616	8348	7807	7391	7057
		20000	19178	15577	12653	11203	10277	9612	9100	8689	8348	8058	7807	7391	6913	6545	6341	5931	5615	5361
		40000	15577	12653	10277	9100	8348	7807	7391	7057	6780	6545	6341	6004	5615	5316	5151	4817	4561	4355
		100000	11833	9612	7807	6913	6341	5931	5615	5361	5151	4972	4817	4561	4265	4038	3913	3659	3465	3308
LB6939 LB6940	LB7975	8000	31990	25984	21106	18688	17143	16033	15180	14494	13924	13441	13023	12330	11531	10918	10578	9893	9366	8943
		20000	24301	19739	16033	14197	13023	12180	11531	11010	10578	10211	9893	9366	8760	8294	8036	7515	7115	6794
		40000	19739	16033	13023	11531	10578	9893	9366	8943	8592	8294	8036	7608	7115	6736	6527	6104	5779	5518
		100000	14995	12180	9893	8760	8036	7515	7115	6794	6527	6300	6104	5779	5405	5117	4958	4637	4390	4192
LB6943	LB7980	8000	35844	29115	23648	20940	19208	17965	17008	16240	15602	15060	14592	13815	12921	12233	11852	11085	10495	10021
		20000	27229	22117	17965	15907	14592	13647	12921	12337	11852	11441	11085	10495	9815	9293	9004	8421	7972	7612
		40000	22117	17965	14592	12921	11852	11085	10495	10021	9627	9293	9004	8524	7972	7548	7313	6840	6476	6183
		100000	16801	13647	11085	9815	9004	8421	7972	7612	7313	7059	6804	6476	6056	5734	5556	5196	4919	4697
LB6947	LB7985	8000	39313	31932	25937	22966	21067	19703	18654	17811	17112	16518	16004	15152	14171	13417	12999	12158	11510	10990
		20000	29864	24257	19703	17447	16004	14968	14171	13531	12999	12548	12158	11510	10765	10192	9875	9236	8744	8349
		40000	24257	19703	16004	14171	12999	12158	11510	10990	10559	10192	9875	9349	8744	8279	8021	7502	7102	6781
		100000	18427	14968	12158	10765	9875	9236	8744	8349	8021	7743	7502	7102	6642	6289	6093	5699	5395	5152
22618	22318	8000	43938	35689	28988	25668	23546	22021	20849	19907	19125	18461	17887	16935	15838	14995	14529	13588	12865	12283
		20000	33378	27111	22021	19499	17887	16729	15838	15122	14529	14024	13588	12865	12032	11391	11037	10322	9773	9331
		40000	27111	22021	17887	15838	14529	13588	12865	12283	11801	11391	11037	10449	9773	9253	8965	8384	7938	7579
		100000	20595	16729	13588	12032	11037	10322	9773	9331	8965	8653	8384	7938	7424	7029	6810	6369	6030	5758
22620	22320	8000	56272	45707	37125	32873	30155	28203	26701	25495	24494	23643	22908	21688	20284	19204	18607	17402	16476	15731
		20000	42747	34722	28203	24973	22908	21424	20284	19367	18607	17961	17402	16476	15409	14589	14135	13220	12516	11950
		40000	34722	28203	22908	20284	18607	17402	16476	15731	15113	14589	14135	13382	12516	11850	11481	10738	10166	9707
		100000	26376	21424	17402	15409	14135	13220	12516	11950	11481	11082	10738	10166	9508	9002	8722	8157	7723	7374
22622	22322	8000	69376	56351	45771	40529	37178	34770	32920	31432	30198	29149	28242	26739	25008	23677	22940	21454	20313	19395
		20000	52702	42807	34770	30788	28242	26414	25008	23877	22940	22143	21454	20313	18997	17986	17426	16298	15431	14733
		40000	42807	34770	28242	25008	22940	21454	20313	19395	18633	17986	17426	16499	15431	14609	14155	13238	12534	11967
		100000	32519	26414	21454	18997	17426	16298	15431	14733	14155	13663	13238	12534	11722	11098	10753	10056	9521	9091
22624	22324	8000	78626	63864	51874	45933	42135	39406	37309	35623	34224	33036	32008	30304	28342	26833	25999	24315	23021	21980
		20000	59729	48515	39406	34893	32008	29935	28342	27061	25999	25096	24315	23021	21530	20384	19750	18471	17488	16698
		40000	48515	39406	32008	28342	25999	24315	23021	21980	21117	20384	19750	18699	17488	16557	16042	15003	14205	13563
		100000	36855	29935	24315	21530	19750	18471	17488	16698	16042	15485	15003	14205	13285	12578	12186	11397	10791	10303
22626	22326	8000	90960	73882	60011	53138	48744	45588	43161	41211	39592	38218	37029	35058	32788	31043	30077	28129	26632	25428
		20000	69098	56125	45588	40367	37029	34631	32788	31306	30077	29033	28129	26632	24908	23582	22848	21369	20231	19317
		40000	56125	45588	37029	32788	30077	28129	26632	25428	24430	23582	22848	21632	20231	19154	18558	17357	16433	15690
		100000	42636	34631	28129	24908	22848	21369	20231	19317	18558	17914	17357	16433	15369	14551	14098	13185	12483	11919
22628	22328	8000	105991	86092	69928	61919	56799	53121	50294	48021	46135	44534	43148	40851	38206	36173	35047	32778	31033	29631
		20000	80517	65400	53121	47037	43148	40354	38206	36480	35047	33830	32778	31033	29024	27479	26624	24900	23574	22509
		40000	65400	53121	43148	38206	35047	32778	31033	29631	28467	27479	26624	25207	23574	22320	21625	20225	19148	18283
		100000	49682	40354	32778	29024	26624	24900	23574	22509	21625	20874	20225	19148	17909	16955	16428	15364	14546	13889
22630	22330	8000	119481	97049	78828	69800	64028	59882	56695	54133	52007	50201	48640	46051	43069	40776	39508	36949	34983	33402
		20000	90765	73724	59882	53024	48640	45490	43069	41122	39508	38136	36949	34983	32717	30976	30012	28069	26575	25374
		40000	73724	59882	48640	43069	39508	36949	34983	33402	32090	30976	30012	28415	26575	25160	24378	22799	21585	20610
		100000	56005	45490	36949	32717	30012	28069	26575	25374	24378	23531	22799	21585	20188	19113	18519	17319	16398	15657
22632	22332	8000	125262	101745	82642	73177	67126	62780	59438	56752	54524	52631	50993	48279	45153	42749	41419	38737	36675	35018
		20000	95156	77291	62780	55589	50993	47691	45153	43112	41419	39981	38737	36675	34301	32475	31464	29427	27861	26602
		40000	77291	62780	50993	45153	41419	38737	36675	35018	33643	32475	31464	29790	27861	26378	25557	23902	22630	21607
		100000	58715	47691	38737	34301	31464	29427	27861	26602	25557	24670	23902	22630</						

Table 6 • Series PLB23000K Load Ratings and Speed Limits

Basic Bearing Number		Co Static Load Rating		C Basic Load Rating		Approximate Speed Limit RPM		e	Fa/Fr ≤ e		Fa/Fr > e	
Adapter Mounted		pounds	newtons	pounds	newtons	Grease	Oil		X1	Y1	X2	Y2
Shaft diameter (inches)	Number											
7-15/16 8	23044K	445100	1980000	254000	1090000	950	1200	0.24	1.00	2.80	0.67	4.10
8-1/2 8-15/16 9	23048K	490000	2180000	260000	1160000	950	1100	0.25	1.00	2.70	0.67	4.10
9-7/16 9-1/2	23052K	580000	2580000	321500	1430000	800	950	0.25	1.00	2.70	0.67	4.10
9-15/16 10 10-7/16	23056K	670000	2980000	345000	1530000	800	950	0.25	1.00	2.70	0.67	4.10
10-15/16 11	23060K	832000	3700000	431600	1920000	670	850	0.24	1.00	2.80	0.67	4.20
11-15/16 12	23064K	865500	3850000	440600	1960000	630	800	0.24	1.00	2.80	0.67	4.20
12-1/2	23068K	989200	4400000	512600	2280000	560	710	0.24	1.00	2.80	0.67	4.20
12-15/16 13	23072K	1056600	4700000	537500	2390000	530	670	0.24	1.00	2.80	0.67	4.20
13-15/16 14	23076K	1146500	5100000	562000	2500000	530	630	0.22	1.00	3.00	0.67	4.50
15	23080K	1326500	5900000	668000	2970000	480	600	0.23	1.00	3.00	0.67	4.40
15-3/4	23084K	1315200	5850000	654200	2910000	450	560	0.23	1.00	2.90	0.67	4.30
16-1/2	23088K	1427500	6350000	708200	3150000	430	530	0.23	1.00	2.90	0.67	4.30
17	23092K	1596200	7100000	775600	3450000	400	500	0.22	1.00	3.10	0.67	4.60
18	23096K	1787200	7950000	854300	3800000	400	480	0.22	1.00	3.10	0.67	4.60
19-1/2	230530K	2068200	9200000	989200	4400000	340	430	0.22	1.00	3.10	0.67	4.60
21	230560K	2405500	10700000	1124000	5000000	320	400	0.22	1.00	3.00	0.67	4.50
22	230600K	2743000	12200000	1225200	5450000	300	360	0.21	1.00	3.30	0.67	4.80
24	230630K	2855000	12700000	1326400	5900000	280	340	0.22	1.00	3.10	0.67	4.70

Table 7 • Radial Load Ratings in Pounds at Various RPM for Appropriate L₁₀ Life Hours

Basic Unit Number	L ₁₀ Minimum Life (hours)	Radial Load Ratings, Pounds											
		Speed, RPM											
		50	100	200	300	400	500	600	700	800	900	1000	1200
23044	8000	*	*	*	57191	52462	49065	46453	44354	42612	41133	39853	37732
	20000	*	60406	49065	43445	39853	37272	35289	33694	32371	31247	30275	28663
	40000	60406	49065	39853	35289	32371	30275	28663	27368	26293	25380	24591	23282
	100000	45888	37272	30275	26807	24591	22998	21774	20790	19974	19280	18680	17686
23048	8000	*	*	*	58542	53701	50224	47551	45402	43619	42104	40794	
	20000	*	61833	50224	44472	40794	38153	36122	34490	33135	31985	30990	
	40000	61833	50224	40794	36122	33135	30990	29340	28014	26914	25980	25172	
	100000	46972	38153	30990	27440	25172	23542	22289	21281	20446	19736	19122	
23052	8000	*	*	*	72389	66403	62104	58798	56141	53936	52064		
	20000	*	76459	62104	54991	50444	47178	44666	42648	40973	39551		
	40000	76459	62104	50444	44666	40973	38320	36280	34641	33281	32125		
	100000	58082	47178	38320	33931	31126	29110	27561	26315	25282	24404		
23056	8000	*	*	*	77680	71257	66643	63096	60244	57879	55869		
	20000	*	82047	66643	59010	54131	50626	47931	45765	43968	42442		
	40000	82047	66643	54131	47931	43968	41121	38932	37173	35713	34473		
	100000	62328	50626	41121	36411	33401	31238	29575	28239	27130	26188		
23060	8000	*	*	*	97179	89144	83372	78934	75367	72407			
	20000	*	102642	83372	73823	67719	63334	59963	57253	55005			
	40000	102642	83372	67719	59963	55005	51443	48705	46504	44678			
	100000	77973	63334	51443	45551	41785	39079	36999	35327	33940			
23064	8000	*	*	*	99205	91003	85110	80580	76938	73917			
	20000	*	104783	85110	75362	69131	64655	61213	58447	56152			
	40000	104783	85110	69131	61213	56152	52516	49721	47474	45609			
	100000	79599	64655	52516	46501	42656	39894	37771	36064	34648			
23068	8000	*	*	*	115417	105874	99018	93748	89511				
	20000	*	121906	99018	87677	80428	75220	71216	67998				
	40000	121906	99018	80428	71216	65328	61098	57846	55231				
	100000	92607	75220	61098	54100	49627	46413	43943	41957				
23072	8000	*	*	*	121024	111017	103828	98302					
	20000	*	127827	103828	91936	84335	78874	74676					
	40000	127827	103828	84335	74676	68501	64065	60655					
	100000	97105	78874	64065	56728	52037	48668	46077					
23076	8000	*	*	*	126540	116077	108561	102782					
	20000	*	133654	108561	96127	88179	82469	78079					
	40000	133654	108561	88179	78079	71623	66986	63420					
	100000	101531	82469	66986	59314	54409	50886	48178					
23080	8000	*	*	*	150407	137970	129037	122168					
	20000	*	158863	129037	114258	104810	98024	92806					
	40000	158863	129037	104810	92806	85132	79620	75382					
	100000	120681	98024	79620	70501	64672	60484	57265					
23084	8000	*	*	*	147300	135120	126371						
	20000	*	155581	126371	111897	102645	95999						
	40000	155581	126371	102645	90889	83374	77975						
	100000	118188	95999	77975	69044	63335	59234						
23088	8000	*	*	*	159458	146273	136802						
	20000	*	168423	136802	121134	111118	103923						
	40000	168423	136802	111118	98391	90256	84411						
	100000	127944	103923	84411	74744	68563	64124						
23092	8000	*	*	*	174634	160194	149822						
	20000	*	184452	149822	132662	121693	113813						
	40000	184452	149822	121693	107755	98845	92445						
	100000	140120	113813	92445	81857	75089	70227						
23096	8000	*	*	*	192354	176449							
	20000	*	203168	165024	146123	134041							
	40000	203168	165024	134041	118689	108875							
	100000	154338	125362	101825	90163	82708							
230530	8000	*	*	*	222728	204312							
	20000	*	235250	191082	169197	155207							
	40000	235250	191082	155207	137431	126067							
	100000	178710	145157	117904	104400	95768							
230560	8000	*	*	*	253080	232154							
	20000	*	267308	217122	192254	176358							
	40000	267308	217122	176358	156159	143247							
	100000	203063	164938	133971	118627	108819							
230600	8000	*	*	*	275866								
	20000	*	291375	236670	209564								
	40000	291375	236670	192236	170219								
	100000	221345	179788	146034	129308								
230630	8000	*	*	*	298652								
	20000	*	315442	256219	226873								
	40000	315442	256219	208114	184279								
	100000	239628	194639	158096	139989								

Table 8 • Series PLB23100K and PLB23100 Load Ratings and Speed Limits

Basic Bearing Number				Co Static Load Rating		C Basic Load Rating		Approximate Speed Limit RPM		e	Fa/Fr ≤ e		Fa/Fr > e	
Adapter Mounted		Direct Shaft Mounted									X1	Y1	X2	Y2
Shaft Diameter (inches)	Number	Bearing Seat (mm)	Number	pounds	newtons	pounds	newtons	Grease	Oil					
8	23144K	NA	NA	609200	2710000	353000	1570000	710	950	0.30	1.00	2.20	0.67	3.30
8-15/16	23148K	NA	NA	697000	3100000	402500	1790000	670	850	0.30	1.00	2.20	0.67	3.30
9-7/16	23152K	260	23152	843000	3750000	485500	2160000	600	800	0.32	1.00	2.10	0.67	3.20
10-7/16	23156K	280	23156	899300	4000000	501500	2230000	560	750	0.30	1.00	2.20	0.67	3.30
10-15/16	23160K	300	23160	1079000	4800000	600500	2670000	500	670	0.31	1.00	2.20	0.67	3.30
11-15/16	23164K	320	23164	1236500	5500000	685700	3050000	480	600	0.31	1.00	2.10	0.67	3.20
12-7/16	23168K	340	23168	1483800	6600000	809500	3600000	430	560	0.31	1.00	2.10	0.67	3.20
13-7/16	23172K	360	23172	1596200	7100000	854500	3800000	400	530	0.31	1.00	2.20	0.67	3.20
13-15/16	23176K	380	23176	1708500	7600000	899200	4000000	400	500	0.30	1.00	2.20	0.67	3.30
15	23180K	400	23180	1776000	7900000	933000	4150000	380	480	0.29	1.00	2.30	0.67	3.40
15-3/4	23184K	420	23184	2113200	9400000	1124000	5000000	340	450	0.31	1.00	2.20	0.67	3.30
16-1/2	23188K	440	23188	2315500	10300000	1191500	5300000	320	430	0.30	1.00	2.20	0.67	3.30
17	23192K	460	23192	2450500	10900000	1281400	5700000	300	400	0.31	1.00	2.20	0.67	3.30
18	23196K	NA	NA	2630500	11700000	1360100	6050000	300	380	0.31	1.00	2.20	0.67	3.30
19-1/2	231530K	NA	NA	3169800	14100000	1607400	7150000	260	340	0.30	1.00	2.20	0.67	3.30
21	231560K	NA	NA	3484500	15500000	1764800	7850000	240	320	0.30	1.00	2.20	0.67	3.40

Table 9 • Radial Load Ratings in Pounds at Various RPM for Appropriate L₁₀ Life Hours

Basic Unit Number	L ₁₀ Minimum Life (hours)	Radial Load Ratings, Pounds									
		Speed, RPM									
		50	100	200	300	400	500	600	700	800	900
23144	8000	*	*	*	79481	72910	68189	64559	61641	59221	57165
	20000	*	83950	68189	60379	55386	51800	49043	46826	44988	43426
	40000	83950	68189	55386	49043	44988	42075	39835	38035	36541	35273
	100000	63773	51800	42075	37256	34175	31962	30261	28893	27759	26795
23148	8000	*	*	*	90627	83133	77750	73612	70285	67525	
	20000	*	95722	77750	68845	63153	59064	55920	53393	51296	
	40000	95722	77750	63153	55920	51296	47975	45421	43368	41665	
	100000	72716	59064	47975	42480	38967	36444	34504	32945	31651	
23152	8000	*	*	*	109315	100276	93783	88792	84779	81450	
	20000	*	115461	93783	83042	76176	71243	67451	64403	61874	
	40000	115461	93783	76176	67451	61874	57868	54787	52311	50257	
	100000	87711	71243	57868	51240	47003	43960	41620	39739	38178	
23156	8000	*	*	*	112918	103581	96874	91718	87573		
	20000	*	119266	96874	85779	78686	73591	69674	66525		
	40000	119266	96874	78686	69674	63913	59775	56593	54035		
	100000	90601	73591	59775	52928	48552	45408	42991	41048		
23160	8000	*	*	*	135209	124029	115998	109823			
	20000	*	142810	115998	102712	94219	88119	83428			
	40000	142810	115998	94219	83428	76530	71575	67765			
	100000	108487	88119	71575	63377	58137	54372	51478			
23164	8000	*	*	*	154392	141626	132456	125405			
	20000	*	163072	132456	117285	107587	100621	95265			
	40000	163072	132456	107587	95265	87388	81730	77379			
	100000	123879	100621	81730	72369	66385	62087	58782			
23168	8000	*	*	*	182267	167196	156370				
	20000	*	192514	156370	138461	127012	118788				
	40000	192514	156370	127012	112465	103166	96486				
	100000	146245	118788	96486	85435	78371	73296				
23172	8000	*	*	*	192399	176491	165063				
	20000	*	203216	165063	146158	134072	125391				
	40000	203216	165063	134072	118717	108901	101849				
	100000	154375	125391	101849	90184	82727	77371				
23176	8000	*	*	*	202464	185723	173697				
	20000	*	213846	173697	153803	141086	131950				
	40000	213846	173697	141086	124927	114597	107177				
	100000	162450	131950	107177	94902	87055	81418				
23180	8000	*	*	*	210074	192704					
	20000	*	221885	180226	159585	146389					
	40000	221885	180226	146389	129623	118905					
	100000	168556	136910	111206	98469	90327					
23184	8000	*	*	*	253080	232154					
	20000	*	267308	217122	192254	176358					
	40000	267308	217122	176358	156159	143247					
	100000	203063	164938	133971	118627	108819					
23188	8000	*	*	*	268278	246096					
	20000	*	283361	230160	203800	186948					
	40000	283361	230160	186948	165537	151849					
	100000	215257	174843	142017	125751	115353					
23192	8000	*	*	*	288520	264664					
	20000	*	304741	247526	219176	201054					
	40000	304741	247526	201054	178027	163306					
	100000	231499	188035	152732	135239	124057					
23196	8000	*	*	*	306240						
	20000	*	323457	262729	232638						
	40000	323457	262729	213402	188961						
	100000	245717	199584	162112	143545						
231530	8000	*	*	*	361922						
	20000	*	382269	310499	274937						
	40000	382269	310499	252204	223318						
	100000	290394	235873	191589	169645						
231560	8000	*	*	*	397362						
	20000	*	419702	340904	301859						
	40000	419702	340904	276900	245186						

Table 10 • Series PLB23200K and PLB23200 Load Ratings and Speed Limits

Basic Bearing Number				Co Static Load Rating		C Basic Load Rating		Approximate Speed Limit RPM		e	Fa/Fr ≤ e		Fa/Fr > e	
Adapter Mounted		Direct Shaft Mounted									X1	Y1	X2	Y2
Shaft Diameter (inches)	Number	Bearing Seat (mm)	Number	pounds	newtons	pounds	newtons	Grease	Oil					
8	23244K	NA	NA	764500	3400000	454000	2020000	670	900	0.35	1.00	1.90	0.67	2.90
8-15/16	23248K	240	23248	910500	4050000	548500	2440000	630	800	0.37	1.00	4.80	0.67	2.70
9-7/16	23252K	260	23252	1022900	4550000	616000	2740000	560	750	0.37	1.00	1.80	0.67	2.70
10-7/16	23256K	280	23256	1101600	4900000	647500	2880000	530	670	0.35	1.00	1.90	0.67	2.90
10-15/16	23260K	300	23260	1326400	5900000	764500	3400000	480	630	0.35	1.00	1.90	0.67	2.90
11-15/16	23264K	320	23264	1551200	6900000	877000	3900000	450	600	0.36	1.00	1.90	0.67	2.80
12-7/16	23268K	340	23268	1753500	7800000	989200	4400000	400	530	0.36	1.00	1.90	0.67	2.80
13-7/16	23272K	360	23272	1922100	8550000	1079000	4800000	380	500	0.36	1.00	1.90	0.67	2.80
13-15/16	23276K	380	23276	2068500	9200000	1157800	5150000	360	480	0.35	1.00	1.90	0.67	2.90
15	23280K	400	23280	2338000	10400000	1303900	5800000	340	450	0.36	1.00	1.90	0.67	2.80
15-3/4	23284K	420	23284	2630500	11700000	1450000	6450000	320	430	0.35	1.00	1.90	0.67	2.90
16-1/2	23288K	440	23288	2877500	12800000	1551200	6900000	300	400	0.35	1.00	1.90	0.67	2.90
17	23292K	460	23292	3080000	13700000	1652400	7350000	280	380	0.36	1.00	1.90	0.67	2.80
18	23296K	NA	NA	3237500	14400000	1764800	7850000	260	360	0.36	1.00	1.90	0.67	2.80

Table 11 • Radial Load Ratings in Pounds at Various RPM for Appropriate L₁₀ Life Hours

Basic Unit Number	L ₁₀ Minimum Life (hours)	Radial Load Ratings, Pounds									
		Speed, RPM									
		50	100	200	300	400	500	600	700	800	900
23244	8000	*	*	*	102223	93770	87699	83031	79278	76165	73521
	20000	*	107970	87699	77654	71233	66621	63075	60224	57859	55851
	40000	107970	87699	71233	63075	57859	54113	51233	48917	46996	45365
	100000	82020	66621	54113	47915	43953	41107	38919	37160	35701	34462
23248	8000	*	*	*	123500	113289	105953	100313	95780	92019	
	20000	*	130443	105953	93818	86061	80488	76204	72760	69903	
	40000	130443	105953	86061	76204	69903	65377	61897	59100	56779	
	100000	99092	80488	65377	57889	53102	49664	47020	44895	43132	
23252	8000	*	*	*	138699	127230	118992	112658	107567		
	20000	*	146496	118992	105363	96651	90393	85582	81714		
	40000	146496	118992	96651	85582	78505	73422	69514	66372		
	100000	111287	90393	73422	65013	59637	55776	52807	50420		
23256	8000	*	*	*	145791	133736	125077	118419			
	20000	*	153987	125077	110751	101594	95015	89958			
	40000	153987	125077	101594	89958	82520	77177	73069			
	100000	116978	95015	77177	68337	62687	58628	55507			
23260	8000	*	*	*	172135	157902	147677	139817			
	20000	*	181812	147677	130764	119951	112184	106213			
	40000	181812	147677	119951	106213	97431	91122	86272			
	100000	138115	112184	91122	80686	74014	69222	65537			
23264	8000	*	*	*	197465	181138	169409	160392			
	20000	*	208567	169409	150006	137603	128693	121843			
	40000	208567	169409	137603	121843	111768	104531	98967			
	100000	158439	128693	104531	92559	84906	79408	75181			
23268	8000	*	*	*	222728	204312	191082				
	20000	*	235250	191082	169197	155207	145157				
	40000	235250	191082	155207	137431	126067	117904				
	100000	178710	145157	117904	104400	95768	89567				
23272	8000	*	*	*	242948	222859	208429				
	20000	*	256606	208429	184557	169297	158335				
	40000	256606	208429	169297	149907	137512	128608				
	100000	194933	158335	128608	113878	104462	97698				
23276	8000	*	*	*	260690	239135					
	20000	*	275346	223651	198035	181661					
	40000	275346	223651	181661	160855	147554					
	100000	209169	169898	138000	122195	112091					
23280	8000	*	*	*	293586	269311					
	20000	*	310092	251873	223025	204584					
	40000	310092	251873	204584	181153	166174					
	100000	235563	191337	155414	137614	126235					
23284	8000	*	*	*	326482	299487					
	20000	*	344837	280095	248015	227507					
	40000	344837	280095	227507	201450	184793					
	100000	261958	212776	172828	153033	140380					
23288	8000	*	*	*	349268	320389					
	20000	*	368904	299643	265324	243386					
	40000	368904	299643	243386	215510	197691					
	100000	280241	227626	184890	163714	150177					
23292	8000	*	*	*	372054						
	20000	*	392971	319192	282634						
	40000	392971	319192	259264	229570						
	100000	298524	242477	196952	174395						
23296	8000	*	*	*	397362						
	20000	*	419702	340904	301859						
	40000	419702	340904	276900	245186						
	100000	318830	258970	210349	186257						

PLB6800, PLB6800F, PLB6600F

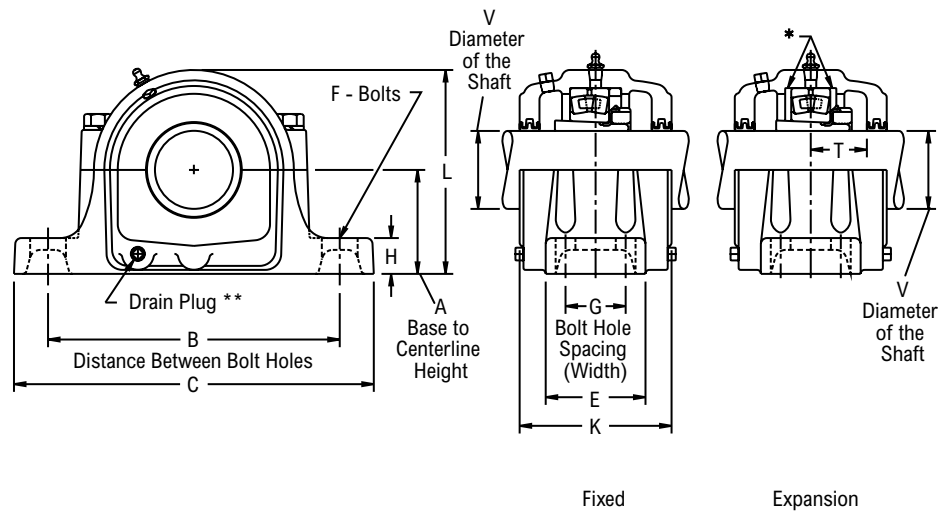
Interchange: USAF 500, SAF22500



Photo Shows a 2-Bolt Spherical Roller Bearing Two-Piece Pillow Block Unit

Product Features

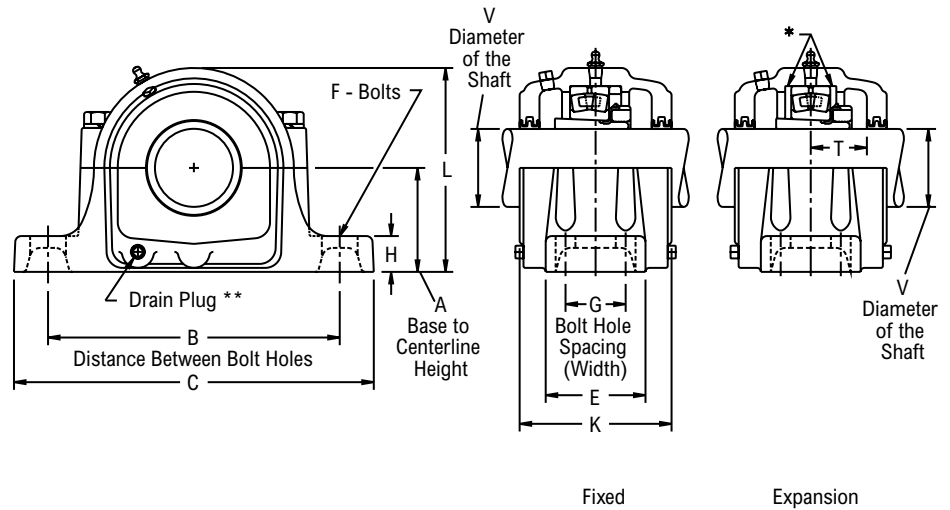
- Corrosion-resistant powder coating
- Two piece cast iron housing
- Broad range of sealing options
- Fixed or Expansion - up to 3/8 in expansion
- Matched base & cap
- Large reservoir for grease or oil storage
- Tapered adapter mounted
- See Features and Benefits for additional info on pages 206 - 207.



Bearing Dimensions

Size Code	V Shaft Diameter	Part Number	A Base to Centerline Height	B Min. Distance Between Bolt Holes	B Max. Distance Between Bolt Holes	G Bolt Hole Spacing (Width)	C	E	F Bolts	H	K	L	P	T	Approx. Weight	
Two-Bolt Pillow Block																
22209	1 7/16	PLB6823R	2 1/4	6 1/4	7	-	8 1/4	2 3/8	1/2	13/16	3 5/8	4 3/8	6 1/4	1 1/16	11.00	
	1 1/2	PLB6824R*														40.00
22210	1 11/16	PLB6827R	2 1/2	6 1/2	7	-	8 1/4	2 3/8	1/2	15/16	3 5/8	4 3/4	6 5/8	1 1/8	12.00	
	1 3/4	PLB6828R*														45.00
22211	1 15/16	PLB6831R	2 3/4	7 3/8	7 7/8	-	9 5/8	2 3/4	5/8	15/16	3 7/8	5 1/4	7 1/4	1 3/16	14.00	
	2	PLB6832R														50.00
22213	2 3/16	PLB6835R	3	8 1/8	9 1/2	-	11	3 1/4	5/8	1	4 3/8	5 15/16	8 1/4	1 13/32	22.00	
	60.00	PLB68M60R*														76.20
22215	2 7/16	PLB6839R	3 1/4	8 5/8	9 5/8	-	11 1/4	3 1/8	5/8	1 1/8	4 3/4	6 3/8	8 3/8	1 15/32	27.00	
	65.00	PLB68M65R														82.55
22216	2 11/16	PLB6843R	3 1/2	9 5/8	11	-	13	3 1/2	3/4	1 1/4	5 1/4	7	9 1/2	1 1/2	38.00	
	70.00	PLB68M70R														88.90
22217	2 15/16	PLB6847R	3 3/4	9 7/8	11	-	13	3 1/2	3/4	1 1/4	5	7 5/16	10	1 19/32	42.00	
	3	PLB6848R														75.00
22218	3 3/16	PLB6851R	4	10 1/4	11 3/4	-	13 3/4	3 7/8	3/4	1 5/16	5 7/8	7 15/16	10 1/2	1 3/4	47.00	
	80.00	PLB68M80R														101.60
22220	3 7/16	PLB6855R	4 1/2	11 5/8	13 1/8	-	15 1/4	4 3/8	7/8	1 1/2	6	8 7/8	11 3/4	1 29/32	71.00	
	3 1/2	PLB6856R														90.00
Four-Bolt Pillow Block																
22215	2 7/16	PLB6839FR	3 1/4	8 5/8	9 5/8	1 7/8	11 1/4	3 1/8	1/2	1 1/8	4 3/4	6 3/8	8 3/8	1 15/32	27.00	
	65.00	PLB68M65FR														82.55
22216	2 11/16	PLB6843FR	3 1/2	9 5/8	11	2	13	3 1/2	5/8	1 1/4	5 1/4	7	9 1/2	1 1/2	38.00	
	70.00	PLB68M70FR														88.90
22217	2 15/16	PLB6847FR	3 3/4	9 7/8	11	2	13	3 1/2	5/8	1 1/4	5	7 5/16	10	1 19/32	42.00	
	3	PLB6848FR														75.00
22218	3 3/16	PLB6851FR	4	10 3/8	11 5/8	2 1/8	13 3/4	3 7/8	5/8	1 5/16	5 7/8	7 15/16	10 1/2	1 3/4	47.00	
	80.00	PLB68M80FR														101.60
22220	3 7/16	PLB6855FR	4 1/2	11 5/8	13 1/8	2 3/8	15 1/4	4 1/2	3/4	1 1/2	6	8 7/8	11 3/4	1 29/32	71.00	
	3 1/2	PLB6856FR														

Continued...

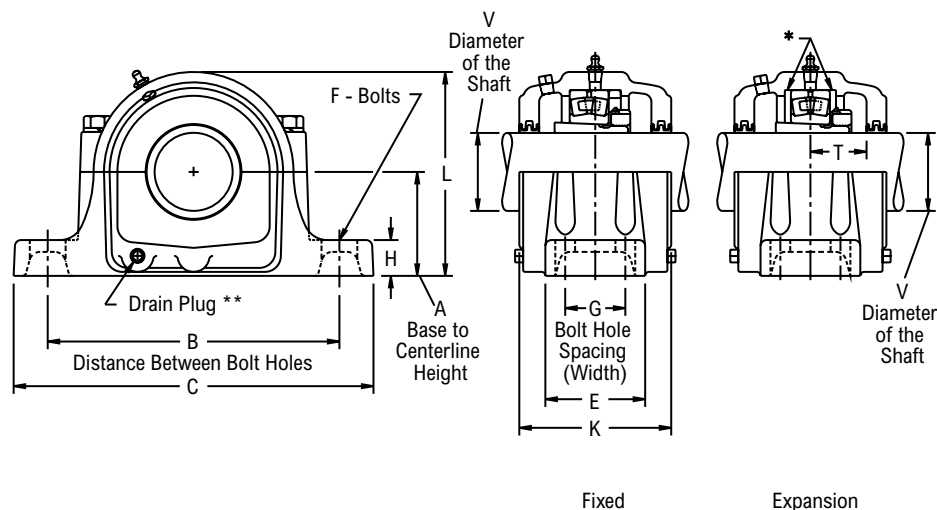


Continued...

Bearing Dimensions

Size Code	V Shaft Diameter	Part Number	A Base to Centerline Height	B Min. Distance Between Bolt Holes	B Max. Distance Between Bolt Holes	G Bolt Hole Spacing (Width)	C	E	F Bolts	H	K	L	P	T	Approx. Weight													
Four-Bolt Pillow Block (continued)																												
22220	90.00	PLB68M90FR	114.30	295.30	333.40	60.30	387.40	114.30	20.00	38.10	152.40	225.40	298.40	48.40	30.80													
22222	3 11/16	PLB6859FR	4 15/16	12 5/8	14 1/2	2 3/4	16 1/2	4 3/4	3/4	2	6 1/2	9 5/8	12 1/4	2 1/8	87.00													
	3 15/16	PLB6863FR																										
	4	PLB6864FR																										
22224	100.00	PLB68M100FR	125.41	320.70	368.30	69.80	419.10	120.60	20.00	50.80	165.10	244.50	311.20	54.00	39.50													
	4 3/16	PLB6867FR	5 1/4	13 1/4	14 1/2	2 3/4	16 1/2	4 3/4	3/4	1 3/4	7 1/8	10 7/16	13 1/2	2 9/32	104.00													
	110.00	PLB68M110FR	133.35	336.60	368.30	69.80	419.10	120.60	20.00	44.40	181.00	265.10	342.90	57.90	47.20													
22226	4 7/16	PLB6871FR	6	14 5/8	16	3 1/4	18 3/8	5 1/8	7/8	2 3/8	7 3/4	11 11/32	14 1/2	2 15/32	149.00													
	4 1/2	PLB6872FR																										
	115.00	PLB68M115FR														152.40	371.50	406.40	82.60	466.70	130.20	24.00	60.33	196.80	288.10	368.30	62.70	63.50
22228	4 15/16	PLB6879FR	6	16	17 1/8	3 3/8	20 1/8	5 7/8	1	2 3/8	7 3/4	11 13/16	15 1/2	2 5/8	167.00													
	5	PLB6880FR																										
	125.00	PLB68M125FR														152.40	406.40	435.00	85.70	511.20	149.20	24.00	60.33	196.80	300.00	393.70	66.70	71.20
22230	5 3/16	PLB6883FR	6 5/16	17	18 1/4	3 3/4	21 1/4	6 1/4	1	2	8 1/8	12 9/16	16	2 3/4	187.00													
	135.00	PLB68M135FR	160.34	431.80	463.60	95.20	539.80	158.80	24.00	50.80	206.40	319.10	406.40	69.80	84.80													
	5 7/16	PLB6887FR	6 11/16	17 3/8	19 1/4	3 3/4	22	6 1/4	1	2 5/8	8 1/2	13 3/8	17	2 31/32	221.00													
22232	140.00	PLB68M140FR	169.86	441.30	489.00	95.20	558.80	158.80	24.00	66.68	215.90	339.70	431.80	75.40	94.80													
	5 15/16	PLB6895FR	7 1/16	19 3/8	21 5/8	4 1/4	24 3/4	6 3/4	1	2 3/4	9 1/4	14 1/4	18	3 1/8	280.00													
	6	PLB6896FR																										
150.00	PLB68M150FR	179.39														492.10	549.30	108.00	628.60	171.40	24.00	69.85	235.00	362.00	457.20	79.40	119.80	
22236	6 7/16	PLB68103FR	7 1/2	20 7/8	23 5/8	4 5/8	26 3/4	7 1/8	1	3	9 7/8	14 15/16	18 3/4	3 5/32	304.00													
	6 1/2	PLB68104FR																										
	160.00	PLB68M160FR														190.50	530.20	600.10	117.50	679.40	181.00	24.00	76.20	250.83	379.40	476.20	80.20	137.90
22238	6 15/16	PLB68111FR	7 7/8	21 5/8	24 3/8	4 1/2	28	7 1/2	1 1/4	3 1/8	10 5/8	15 13/16	20 1/2	3 5/16	370.00													
	7	PLB68112FR																										
	170.00	PLB68M170FR														200.02	549.30	619.10	114.30	711.20	190.50	30.00	79.38	269.88	401.60	520.70	84.10	167.80
22240	7 3/16	PLB68115FR	8 1/4	22 1/2	25	5	29 1/2	8	1 1/4	2 3/8	11	16 3/4	22 1/4	3 17/32	450.00													
	180.00	PLB68M180FR														209.55	571.50	635.00	127.00	749.30	203.20	30.00	60.30	279.40	425.40	565.20	89.70	204.10
	7 1/2	PLB68120FR														9 1/2	24 3/4	27 7/8	5 1/4	32 3/4	8 3/4	1 1/2	3 3/4	11 3/16	18 9/16	24 1/2	3 13/16	675.00
7 15/16	PLB22544K71516																											
	PLB68127FR																											
	PLB22544K8																											
	PLB68128FR																											
200.00	PLB68M200FR	241.30	628.60	708.00	133.40	831.80	222.20	36.00	95.25	284.20	471.50	622.30	96.80	301.60														

Continued...



Continued...

Bearing Dimensions

Size Code	V Shaft Diameter	Part Number	A Base to Centerline Height	B Min. Distance Between Bolt Holes	B Max. Distance Between Bolt Holes	G Bolt Hole Spacing (Width)	C	E	F Bolts	H	K	L	P	T	Approx. Weight
Four-Bolt Pillow Block (continued)															
22248	8 7/16	PLB22548K8716	10 1/4	29	30 1/2	8 3/4	35	14 1/2	1 5/8	3 3/4	14 1/8	20 1/2	-	-	1,000.00
	8 15/16	PLB22548K81516													
23048	8 7/16	PLB66135FR	8 1/4	22 1/2	25	5	29 1/2	8	1 1/4	2 3/8	11	16 3/4	22 1/4	3 13/16	430.00
	8 1/2	PLB66136FR													
	9	PLB66144FR													
	220.00	PLB66M220FR	209.55	571.50	635.00	127.00	749.30	203.20	30.00	60.30	279.40	425.40	565.20	96.80	195.00
23056	9 15/16	PLB66159FR	9 1/2	24 3/4	27 7/8	5 1/4	32 3/4	8 3/4	1 1/2	3 3/4	11 3/4	19 1/16	24 1/2	4 1/4	540.00
	10	PLB66160FR													530.00
	10 7/16	PLB66167FR													515.00
	10 1/2	PLB66168FR													510.00
	9 7/16	PLB66B151FR													550.00
	9 1/2	PLB66B152FR													545.00
260.00	PLB66M260FR	241.30	628.60	708.00	133.40	831.80	222.20	36.00	95.25	298.40	484.20	622.30	108.00	247.20	

Additional Notes

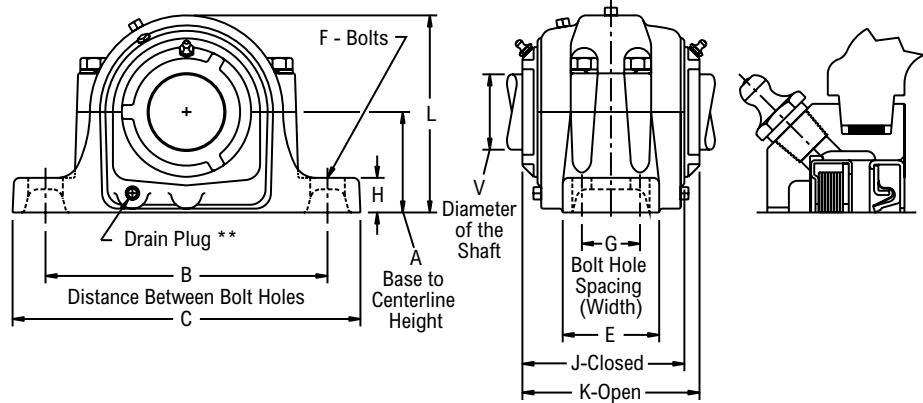
Please call 1-866-REXNORD for availability
 Lubrication fitting tap size: for 4 1/2 in (115 mm) and smaller shaft sizes, 1/8 in PT: for all other shaft sizes, 1/4 in PT
 Expansion - is 1/4 in for 1 3/4 in (40 mm) and smaller shaft sizes: all other shaft sizes provide 3/8"
 Drain plug tap size - for 3 3/16 in (80 mm) and smaller shaft sizes, 1/8 in PT: for 3 7/16 in (90 mm) thru 6 in (150 mm), 1/4 in PT: for all other shaft sizes, 1/2 in PT
 Minimum extension of shaft beyond locknut, .06 in for closed end unit

Dimension "P" is recommended dimension for cap removal
 Multi-labyrinth seals standard
 All shaft sizes available with type D5 Pentac seals except when marked with a "*".
 For the Selection Guide, Load Ratings and Speed Limits, see the Link-Belt Split Housed Spherical Roller Bearings Engineering section on pages 210 - 223.
 Note: Dimensions subject to change. Certified dimensions of ordered material furnished on request.

PLB6800D8, PLB6800FD8, PLB6600FD8



Photo Shows a 2-Bolt Spherical Roller Bearing Two-Piece Pillow Block Unit with Independently Flushable Seals



Product Features

- Corrosion-resistant powder coating
- Two piece cast iron housing
- Independently flushable seals
- Fixed or Expansion - up to 3/8 in expansion
- Matched base & cap
- Large reservoir for grease or oil storage
- Tapered adapter mounted
- See Features and Benefits for additional info on pages 206 - 207.

Bearing Dimensions

Size Code	V Shaft Diameter	Part Number	A Base to Centerline Height	B Min. Distance Between Bolt Holes	B Max. Distance Between Bolt Holes	G Bolt Hole Spacing (Width)	C	E	F Bolts	H	J	K	L	P	Approx. Weight
Two-Bolt Pillow Block															
22209	1 7/16	PLB6823D8	2 1/4	6 1/4	7	-	8 1/4	2 3/8	1/2	13/16	4 7/16	5	4 3/8	6 1/4	12.00
	1 1/2	PLB6824D8													11.00
22210	1 11/16	PLB6827D8	2 1/2	6 1/2	7	-	8 1/4	2 3/8	1/2	15/16	4 13/32	4 15/16	4 3/4	6 5/8	13.00
22211	1 15/16	PLB6831D8	2 3/4	7 3/8	7 7/8	-	9 5/8	2 3/4	5/8	15/16	4 23/32	5 5/16	5 1/4	7 1/4	16.00
		2													PLB6832D8
22213	2 3/16	PLB6835D8	3	8 1/8	9 1/2	-	11	3 1/4	5/8	1	5 1/8	5 5/8	5 15/16	8 1/4	24.00
22215	2 7/16	PLB6839D8	3 1/4	8 5/8	9 5/8	-	11 1/4	3 1/8	5/8	1 1/8	5 11/32	5 15/16	6 3/8	8 3/8	30.00
22216	2 11/16	PLB6843D8	3 1/2	9 5/8	11	-	13	3 1/2	3/4	1 1/4	6 1/32	6 9/16	7	9 1/2	38.00
22217	2 15/16	PLB6847D8	3 3/4	9 7/8	11	-	13	3 1/2	3/4	1 1/4	5 11/16	6 3/8	7 5/16	10	47.00
		3													PLB6848D8
22218	3 3/16	PLB6851D8	4	10 1/4	11 3/4	-	13 3/4	3 7/8	3/4	1 5/16	6 3/4	7 3/8	7 15/16	10 1/2	52.00
22220	3 7/16	PLB6855D8	4 1/2	11 5/8	13 1/8	-	15 1/4	4 3/8	7/8	1 1/2	6 21/32	7 5/16	8 7/8	11 3/4	79.00
Four-Bolt Pillow Block															
22215	2 7/16	PLB6839FD8	3 1/4	8 5/8	9 5/8	1 7/8	11 1/4	3 1/8	1/2	1 1/8	5 17/32	5 15/16	6 3/8	8 3/8	30.00
22217	2 15/16	PLB6847FD8	3 3/4	9 7/8	11	2	13	3 1/2	5/8	1 1/4	5 11/16	6 3/8	7 5/16	10	47.00
22218	3 3/16	PLB6851FD8	4	10 3/8	11 5/8	2 1/8	13 3/4	3 7/8	5/8	1 5/16	6 3/4	7 3/8	7 15/16	10 1/2	52.00
22220	3 7/16	PLB6855FD8	4 1/2	11 5/8	13 1/8	2 3/8	15 1/4	4 1/2	3/4	1 1/2	6 21/32	7 5/16	8 7/8	11 3/4	79.00
22222	3 11/16	PLB6859FD8	4 15/16	12 5/8	14 1/2	2 3/4	16 1/2	4 3/4	3/4	2	7 7/32	7 15/16	9 5/8	12 1/4	98.00
		3 15/16													PLB6863FD8
22224	4 3/16	PLB6867FD8	5 1/4	13 1/4	14 1/2	2 3/4	16 1/2	4 3/4	3/4	1 3/4	7 31/32	8 9/16	10 7/16	13 1/2	116.00
22226	4 7/16	PLB6871FD8	6	14 5/8	16	3 1/4	18 3/8	5 1/8	7/8	2 3/8	8 31/64	9 7/32	11 19/32	14 1/2	165.00
22228	4 15/16	PLB6879FD8	6	16	17 1/8	3 3/8	20 1/8	5 7/8	1	2 3/8	8 7/32	8 15/16	11 13/16	15 1/2	184.00
22232	5 7/16	PLB6887FD8	6 11/16	17 3/8	19 1/4	3 3/4	22	6 1/4	1	2 5/8	9 3/32	9 13/16	13 3/8	17	244.00
22234	5 15/16	PLB6895FD8	7 1/16	19 3/8	21 5/8	4 1/4	24 3/4	6 3/4	1	2 3/4	10 1/8	11	14 1/4	18	309.00
		6													PLB6896FD8
22236	6 7/16	PLB68103FD8	7 1/2	20 7/8	23 5/8	4 5/8	26 3/4	7 1/8	1	3	10 11/16	11 3/8	14 15/16	18 3/4	322.00
		6 1/2													PLB68104FD8
22238	6 15/16	PLB68111FD8	7 7/8	21 5/8	24 3/8	4 1/2	28	7 1/2	1 1/4	3 1/8	11 11/32	12 1/16	15 13/16	20 1/2	411.00
		7													PLB68112FD8
22244	7 1/2	PLB68120FD8	9 1/2	24 3/4	27 7/8	5 1/4	32 3/4	8 3/4	1 1/2	3 3/4	12 3/16	13 3/16	18 9/16	24 1/2	750.00
		7 15/16													PLB68127FD8
		8													PLB68128FD8
23048	8 7/16	PLB66135FD8	8 1/4	22 1/2	25	5	29 1/2	8	1 1/4	2 3/8	12 1/32	12 11/16	16 3/4	22 1/4	478.00
		8 1/2													PLB66136FD8
23056	9 1/2	PLB66144FD8	9 1/2	24 3/4	27 7/8	5 1/4	32 3/4	8 3/4	1 1/2	2 3/4	13 9/32	14 7/16	19 1/16	24 1/2	605.00
		10 1/2													PLB66168FD8

Additional Notes

- Please call 1-866-REXNORD for availability
- Lubrication fitting tap size: for 4 1/2 in (115 mm) and smaller shaft sizes, 1/8 in PT: for all other shaft sizes, 1/4 in PT
- Seal assembly lubrication fitting tap size: for 1 3/4 in and smaller shaft sizes, 1/4-28 UNF: for all other shaft sizes, 1/8 in PT
- Recommended shaft finish under D8 seals, 10-20 micro inches
- Expansion - is 1/4 in for 1 3/4 in (40 mm) and smaller shaft sizes: all other shaft sizes provide 3/8 in

- Drain plug tap size - for 3 3/16 in (80 mm) and smaller shaft sizes, 1/8 in PT: for 3 7/16 in (90 mm) thru 6 in (150 mm), 1/4 in PT: for all other shaft sizes, 1/2 in PT
- Minimum extension of shaft beyond locknut, .06 in for closed end unit
- Dimension "P" is recommended dimension for cap removal
- Taconite seals standard
- For the Selection Guide, Load Ratings and Speed Limits, see the Link-Belt Split Housed Spherical Roller Bearings Engineering section on pages 210 - 223.
- Note: Dimensions subject to change. Certified dimensions of ordered material furnished on request.

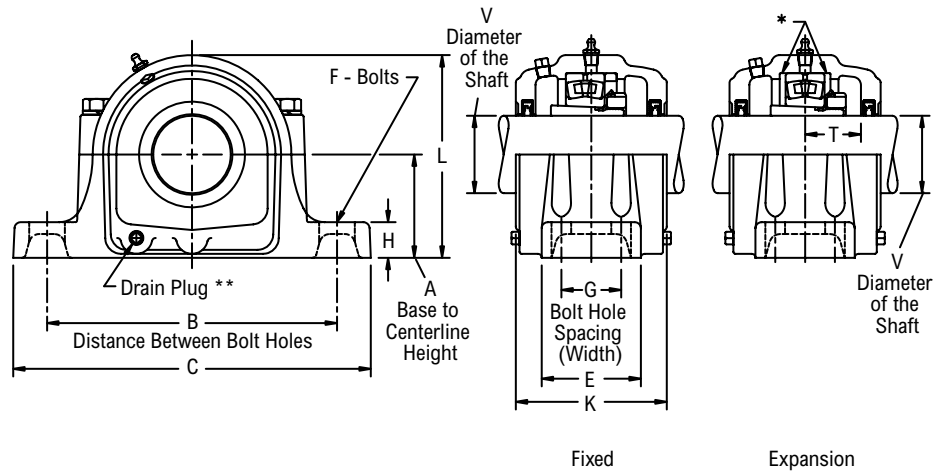
BPLB6800



Photo Shows a 2-Bolt Spherical Roller Bearing Two-Piece Pillow Block Unit

Product Features

- Corrosion-resistant nylon coating
- Two piece cast iron housing
- Stainless steel hardware
- Patented T contact water seal
- Fixed or Expansion - up to 3/8 in expansion
- Matched base & cap
- Large reservoir for grease or oil storage
- Tapered adapter mounted
- See Features and Benefits for additional info on pages 206 - 207.



Bearing Dimensions

Size Code	V Shaft Diameter	Part Number	A Base to Centerline Height	B Min. Distance Between Bolt Holes	B Max. Distance Between Bolt Holes	G Bolt Hole Spacing (Width)	C	E	F Bolts	H	K	L	P	T	Approx. Weight
Two-Bolt Pillow Block															
22209	1 7/16	BPLB6823	2 1/4	6 1/4	7	-	8 1/4	2 3/8	1/2	13/16	3 5/8	4 3/8	6 1/4	1 1/16	11.00
22213	2 3/16	BPLB6835	3	8 1/8	9 1/2	-	11	3 1/4	5/8	1	4 3/8	5 15/16	8 1/4	1 13/32	22.00
22215	2 7/16	BPLB6839	3 1/4	8 5/8	9 5/8	-	11 1/4	3 1/8	5/8	1 1/8	4 3/4	6 3/8	8 3/8	1 15/32	27.00
22216	2 11/16	BPLB6843	3 1/2	9 5/8	11	-	13	3 1/2	3/4	1 1/4	5 1/4	7	9 1/2	1 1/2	38.00
22217	2 15/16	BPLB6847	3 3/4	9 7/8	11	-	13	3 1/2	3/4	1 1/4	5	7 5/16	10	1 19/32	42.00
22218	3 3/16	BPLB6851	4	10 1/4	11 3/4	-	13 3/4	3 7/8	3/4	1 5/16	5 7/8	7 15/16	10 1/2	1 3/4	47.00
Four-Bolt Pillow Block															
22215	2 7/16	BPLB6839F	3 1/4	8 5/8	9 5/8	1 7/8	11 1/4	3 1/8	1/2	1 1/8	4 3/4	6 3/8	8 3/8	1 15/32	27.00
22216	2 11/16	BPLB6843F	3 1/2	9 5/8	11	2	13	3 1/2	5/8	1 1/4	5 1/4	7	9 1/2	1 1/2	38.00
22217	2 15/16	BPLB6847F	3 3/4	9 7/8	11	2	13	3 1/2	5/8	1 1/4	5	7 5/16	10	1 19/32	42.00
22218	3 3/16	BPLB6851F	4	10 3/8	11 5/8	2 1/8	13 3/4	3 7/8	5/8	1 5/16	5 7/8	7 15/16	10 1/2	1 3/4	47.00
22222	3 15/16	BPLB6863F	4 15/16	12 5/8	14 1/2	2 3/4	16 1/2	4 3/4	3/4	2	6 1/2	9 5/8	12 1/4	2 1/8	87.00
22226	4 1/2	BPLB6872F	6	14 5/8	16	3 1/4	18 3/8	5 1/8	7/8	2 3/8	7 3/4	11 11/32	14 1/2	2 15/32	149.00
22228	4 15/16	BPLB6879F	6	16	17 1/8	3 3/8	20 1/8	5 7/8	1	2 3/8	7 3/4	11 13/16	15 1/2	2 5/8	167.00

Additional Notes

- Please call 1-866-REXNORD for availability
- Lubrication fitting tap size: for 4 1/2 in and smaller shaft sizes, 1/8 in PT; for all other shaft sizes, 1/4 in PT
- Expansion - is 1/4 in for 1 7/16 in : all other shaft sizes provide 3/8 in
- Drain plug tap size - for 3 3/16 in and smaller shaft sizes, 1/8 in PT; for all other shaft sizes, 1/4 in PT
- Minimum extension of shaft beyond locknut, .06 in for closed end unit
- Dimension "P" is recommended dimension for cap removal

- Exclusive T water seals standard
- For the Selection Guide, Load Ratings and Speed Limits, see the Link-Belt Split Housed Spherical Roller Bearings Engineering section on pages 210 - 223.
- Note: Dimensions subject to change. Certified dimensions of ordered material furnished on request.

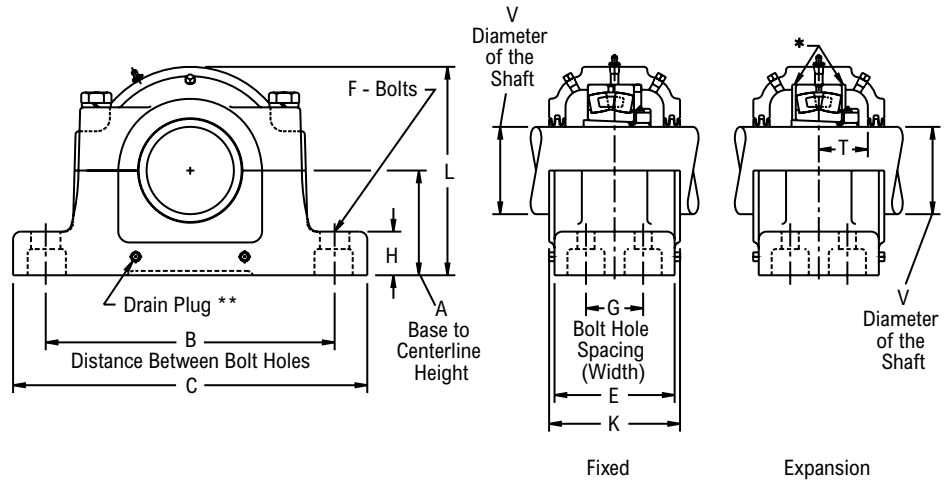
PKLB6800F, PKLB6600F



Photo Shows a 4-Bolt Spherical Roller Bearing Two-Piece Pillow Block Unit

Product Features

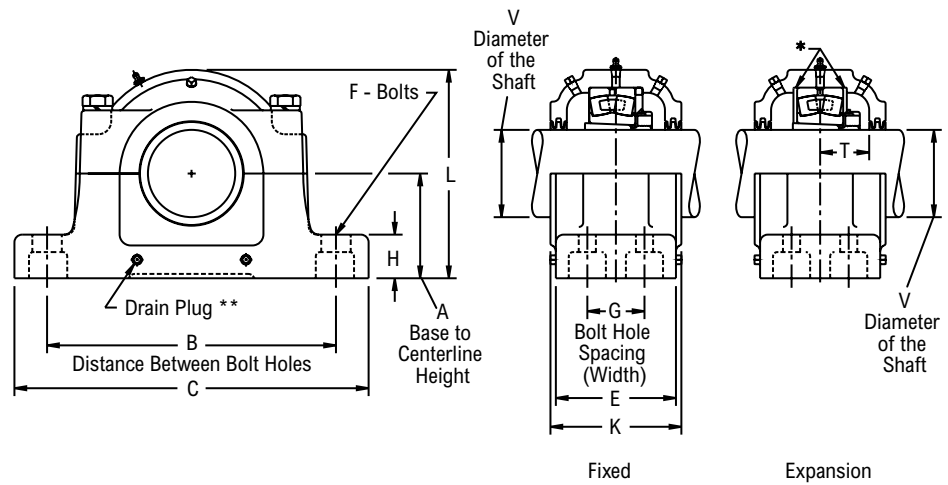
- Corrosion-resistant powder coating
- Two piece cast steel housing
- Broad range of sealing options
- Fixed or Expansion - up to 3/8 in expansion
- Matched base & cap
- Large reservoir for grease or oil storage
- Tapered adapter mounted
- See Features and Benefits for additional info on pages 206 - 207.



Bearing Dimensions

Size Code	V Shaft Diameter	Part Number	A Base to Centerline Height	B Min. Distance Between Bolt Holes	B Max. Distance Between Bolt Holes	G Bolt Hole Spacing (Width)	C	E	F Bolts	H	K	L	P	T	Approx. Weight
22215	2 7/16	PKLB6839FR	3 1/4	8 5/8	9 5/8	1 7/8	11 1/4	4 3/8	1/2	1 1/2	4 3/4	6 3/8	10 1/4	1 15/32	37.00
	65.00	PKLB68M65FR	82.55	219.10	244.50	47.60	285.80	111.10	12.00	38.10	120.60	161.90	260.40	37.30	16.80
22216	2 11/16	PKLB6843FR	3 1/2	9 5/8	11	2	13	4 7/8	5/8	1 5/8	5 1/4	7	11	1 1/2	51.00
	70.00	PKLB68M70FR	88.90	244.50	279.40	50.80	330.20	123.80	16.00	41.30	133.40	177.80	279.40	38.10	23.10
22217	2 15/16	PKLB6847FR	3 3/4	9 7/8	11	2	13	4 7/8	5/8	1 5/8	5 1/4	7 3/8	11 1/2	1 19/32	51.00
	3	PKLB6848FR													
22217	75.00	PKLB68M75FR	95.25	250.80	279.40	50.80	330.20	123.80	16.00	41.30	133.40	187.30	292.10	40.50	23.10
	3 7/16	PKLB6855FR	4 1/2	11 5/8	13 1/8	2 3/8	15 1/4	6	3/4	1 7/8	6 1/2	8 13/16	13 3/4	1 29/32	97.00
3 1/2	PKLB6856FR														
22220	90.00	PKLB68M90FR	114.30	295.30	333.40	60.30	387.40	152.40	20.00	47.60	165.10	223.80	349.20	48.40	44.00
	3 11/16	PKLB6859FR	4 15/16	12 5/8	14 1/2	2 3/4	16 1/2	6 1/2	3/4	2	7	9 3/4	15 1/4	2 1/8	112.00
3 15/16	PKLB6863FR														
4	PKLB6864FR														
22222	100.00	PKLB68M100FR	125.41	320.70	368.30	69.80	419.10	165.10	20.00	50.80	177.80	247.60	387.40	54.00	50.80
	4 7/16	PKLB6871FR	6	14 5/8	16	3 1/4	18 3/8	7 1/4	7/8	2 1/4	7 3/4	11 1/2	18 1/4	2 15/32	200.00
4 1/2	PKLB6872FR														
115.00	PKLB68M115FR	152.40													
22228	4 15/16	PKLB6879FR	6	16	17 1/8	3 3/8	20 1/8	6 7/8	1	2 1/2	7 1/2	11 15/16	19 1/4	2 5/8	207.00
	5	PKLB6880FR													
22232	125.00	PKLB68M125FR	152.40	406.40	435.00	85.70	511.20	174.60	24.00	63.50	190.50	303.20	489.00	66.70	93.90
	5 7/16	PKLB6887FR	6 11/16	17 3/8	19 1/4	3 3/4	22	8	1	2 3/4	8 1/2	13 1/2	20 1/2	2 31/32	270.00
22234	140.00	PKLB68M140FR	169.86	441.30	489.00	95.20	558.80	203.20	24.00	69.80	215.90	342.90	520.70	75.40	122.50
	5 15/16	PKLB6895FR	7 1/16	19 3/8	21 5/8	4 1/4	24 3/4	8 3/4	1	3	9 1/4	14 1/4	22 1/4	3 1/8	368.00
6	PKLB6896FR														
22236	150.00	PKLB68M150FR	179.39	492.10	549.30	108.00	628.60	222.20	24.00	76.20	235.00	362.00	565.20	79.40	166.90
	6 7/16	PKLB68103FR	7 1/2	20 7/8	23 5/8	4 5/8	26 3/4	9 1/8	1	3 1/4	9 5/8	14 15/16	23 1/4	3 5/32	390.00
6 1/2	PKLB68104FR														
22238	160.00	PKLB68M160FR	190.50	530.20	600.10	117.50	679.40	231.80	24.00	82.60	244.50	379.40	590.60	80.20	176.90
	6 15/16	PKLB68111FR	7 7/8	21 5/8	24 3/8	4 1/2	28	9 3/4	1 1/4	3 1/4	10 1/4	15 13/16	25	3 5/16	470.00
7	PKLB68112FR														
22244	170.00	PKLB68M170FR	200.02	549.30	619.10	114.30	711.20	247.60	30.00	82.60	260.40	401.60	635.00	84.10	213.20
	7 1/2	PKLB68120FR	9 1/2	25 7/8	27 5/8	7 1/4	32	12	1 3/4	4	12 5/8	18 11/16	29 1/4	3 13/16	875.00
	7 15/16	PKLB68127FR													
8	PKLB68128FR	830.00													

Continued...



Continued...

Bearing Dimensions

Size Code	V Shaft Diameter	Part Number	A Base to Centerline Height	B Min. Distance Between Bolt Holes	B Max. Distance Between Bolt Holes	G Bolt Hole Spacing (Width)	C	E	F Bolts	H	K	L	P	T	Approx. Weight
22244	200.00	PKLB68M200FR	241.30	657.20	701.70	184.20	812.80	304.80	48.00	101.60	320.70	474.70	743.00	96.80	376.50
23048	8 1/2	PKLB66136FR*	8 1/4	22 1/2	25	5	29 1/2	10 3/8	1 1/4	3 1/2	11	16 1/2	26 1/2	3 13/16	562.00
	9	PKLB66144FR													528.00
	220.00	PKLB66M220FR	209.55	571.50	635.00	127.00	749.30	263.50	30.00	88.90	279.40	419.10	673.10	96.80	240.40
23056	9 1/2	PKLB66B152FR	9 1/2	25 7/8	27 5/8	7 1/4	32	12	1 3/4	4	12 5/8	18 11/16	29 1/4	4 1/4	800.00
	9 15/16	PKLB66159FR													790.00
	10	PKLB66160FR													780.00
	10 1/2	PKLB66168FR													770.00
	260.00	PKLB66M260FR	241.30	657.20	701.70	184.20	812.80	304.80	48.00	101.60	320.70	474.70	743.00	108.00	358.30

Additional Notes

- Please call 1-866-REXNORD for availability
- Lubrication fitting tap size, 1/4 in PT
- Expansion - is 3/8 in for all shaft sizes
- Drain plug tap size - for 6 in (150 mm) and smaller shaft sizes, 1/4 in PT; for all other shaft sizes, 1/2 in PT
- Minimum extension of shaft beyond locknut, .06 in for closed end unit
- Dimension "P" is recommended dimension for cap removal
- Multi-labyrinth seals standard

- All shaft sizes available with type D5 Pentac seals except when marked with a "**".
- For the Selection Guide, Load Ratings and Speed Limits, see the Link-Belt Split Housed Spherical Roller Bearings Engineering section on pages 210 - 223.
- Note: Dimensions subject to change. Certified dimensions of ordered material furnished on request.

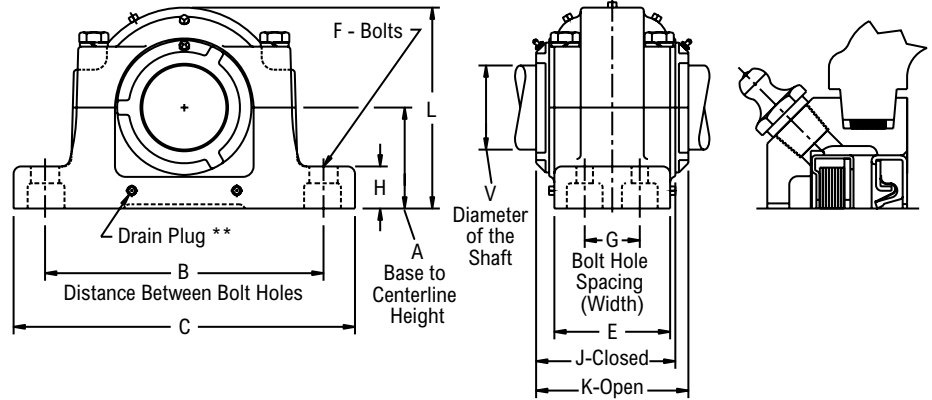
PKLB6800FD8



Photo Shows a 2-Bolt Spherical Roller Bearing Two-Piece Pillow Block Unit with Independently Flushable Seals

Product Features

- Corrosion-resistant powder coating
- Two piece cast steel housing
- Independently flushable seals
- Fixed or Expansion - up to 3/8 in expansion
- Matched base & cap
- Large reservoir for grease or oil storage
- Tapered adapter mounted
- See Features and Benefits for additional info on pages 206 - 207.



Bearing Dimensions

Size Code	V Shaft Diameter	Part Number	A Base to Centerline Height	B Min. Distance Between Bolt Holes	B Max. Distance Between Bolt Holes	G Bolt Hole Spacing (Width)	C	E	F Bolts	H	J	K	L	P	Approx. Weight
22215	2 7/16	PKLB6839FD8	3 1/4	8 5/8	9 5/8	1 7/8	11 1/4	4 3/8	1/2	1 1/2	5 17/32	6 1/16	6 3/8	10 1/4	41.00
22217	2 15/16	PKLB6847FD8	3 3/4	9 7/8	11	2	13	4 7/8	5/8	1 5/8	6 1/16	6 5/8	7 3/8	11 1/2	57.00
22220	3 7/16	PKLB6855FD8	4 1/2	11 5/8	13 1/8	2 3/8	15 1/4	6	3/4	1 7/8	6 21/32	7 5/16	8 13/16	13 3/4	97.00
22226	4 7/16	PKLB6871FD8	6	14 5/8	16	3 1/4	18 3/8	7 1/4	7/8	2 1/4	8 5/8	9 1/4	11 1/2	18 1/4	190.00
22228	4 15/16	PKLB6879FD8	6	16	17 1/8	3 3/8	20 1/8	6 7/8	1	2 1/2	8 3/8	9	11 15/16	19 1/4	210.00
22236	6 7/16	PKLB68103FD8	7 1/2	20 7/8	23 3/8	4 5/8	26 3/4	9 1/8	1	3 1/4	10 11/16	11 3/8	14 15/16	23 1/4	422.00

Additional Notes

- Please call 1-866-REXNORD for availability
- Lubrication fitting tap size, 1/4 in PT
- Seal assembly lubrication fitting tap size, 1/8 in PT
- Recommended shaft finish under D8 seals, 10-20 micro inches
- Expansion - is 3/8 in for all shaft sizes
- Drain plug tap size - for 4 15/16 in and smaller shaft sizes, 1/4 in PT; for all other shaft sizes, 1/2 in PT
- Minimum extension of shaft beyond locknut, .06 in for closed end unit

- Dimension "P" is recommended dimension for cap removal
- Taconite seals standard
- For the Selection Guide, Load Ratings and Speed Limits, see the Link-Belt Split Housed Spherical Roller Bearings Engineering section on pages 210 - 223.
- Note: Dimensions subject to change. Certified dimensions of ordered material furnished on request.

PLB6900, PLB6900F, SAF22600

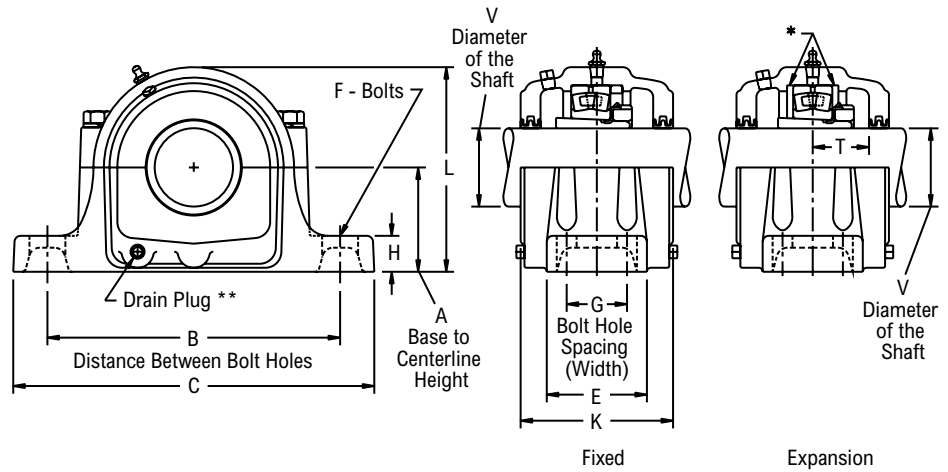
Interchange: USAF 600, SAF22600



Photo Shows a 2-Bolt Spherical Roller Bearing Two-Piece Pillow Block Unit

Product Features

- Corrosion-resistant powder coating
- Two piece cast iron housing
- Broad range of sealing options
- Fixed or Expansion - up to 3/8 in expansion
- Matched base & cap
- Large reservoir for grease or oil storage
- Tapered adapter mounted
- See Features and Benefits for additional info on pages 206 - 207.



Bearing Dimensions

Size Code	V Shaft Diameter	Part Number	A Base to Centerline Height	B Min. Distance Between Bolt Holes	B Max. Distance Between Bolt Holes	G Bolt Hole Spacing (Width)	C	E	F Bolts	H	K	L	P	T	Approx. Weight
Two-Bolt Pillow Block															
22309	1 7/16	PLB6923R	2 3/4	7 1/4	8	-	9 5/8	2 3/4	5/8	1	4 1/8	5 3/8	7 1/2	1 5/16	20.00
	1 1/2	PLB6924R*													
22310	1 11/16	PLB6927R	3	7 3/4	9	-	10 5/8	2 3/4	5/8	1 1/8	4 1/2	5 7/8	7 7/8	1 15/32	23.00
22311	1 15/16	PLB6931R	3 1/4	8 1/8	9 1/2	-	11	3 1/8	5/8	1 3/16	4 3/4	6 5/16	8 1/2	1 9/16	28.00
	2	PLB6932R													
22313	2 3/16	PLB6935R	3 1/2	9 5/8	11	-	13	3 1/2	3/4	1 1/4	5 1/4	7	9 5/8	1 23/32	41.00
22315	2 7/16	PLB6939R	4	10 3/8	11 5/8	-	13 3/4	3 7/8	3/4	1 5/16	5 7/8	7 15/16	10 1/2	1 15/16	52.00
	2 1/2	PLB6940R													
22316	2 11/16	PLB6943R	4 1/4	10 5/8	12 5/8	-	14 1/4	3 7/8	3/4	1 5/16	6 1/8	8 3/8	11 1/4	2	59.00
22317	2 15/16	PLB6947R	4 1/2	11 5/8	13 1/8	-	15 1/4	4 3/8	7/8	1 1/2	6 1/2	8 7/8	11 3/4	2 1/2	71.00
Four-Bolt Pillow Block															
22313	2 3/16	PLB6935FR	3 1/2	9 5/8	11	2	13	3 1/2	5/8	1 1/4	5 1/4	7	9 5/8	1 23/32	41.00
22315	2 7/16	PLB6939FR	4	10 3/8	11 5/8	2 1/8	13 3/4	3 7/8	5/8	1 5/16	5 7/8	7 15/16	10 1/2	1 15/16	52.00
	2 1/2	PLB6940FR													
22316	2 11/16	PLB6943FR	4 1/4	10 5/8	12 5/8	2 1/4	14 1/4	3 7/8	5/8	1 5/16	6 1/8	8 3/8	11 1/4	2	59.00
22317	2 15/16	PLB6947FR	4 1/2	11 5/8	13 1/8	2 3/8	15 1/4	4 3/8	3/4	1 1/2	6 1/2	8 7/8	11 3/4	2 1/2	71.00
22318	3 3/16	SAF22618303	4 3/4	12	13 1/2	2 1/4	15 1/2	4 3/8	3/4	2	6 7/8	9 1/4	12 1/4	2 7/32	97.00
22320	3 7/16	SAF22620307	5 1/4	13 1/4	14 1/2	2 3/4	16 1/2	4 3/4	3/4	1 3/4	7 1/8	10 7/16	13 1/2	2 7/16	111.00
	3 1/2	SAF22620308													
22322	3 15/16	SAF22622315	6	14 5/8	16	3 1/4	18 3/8	5 1/8	7/8	1 7/8	7 3/4	11 11/16	14 1/2	2 21/32	149.00
	4	SAF22622400													
22324	4 3/16	SAF22624403	6 5/16	17	18 1/4	3 3/4	21 1/4	6 1/4	1	2 1/2	8 3/8	12 1/2	16	2 13/16	225.00
22326	4 7/16	SAF22626407	6 11/16	17 3/8	19 1/4	3 3/4	22	6 1/4	1	2 5/8	8 3/4	13 5/16	17	3 5/16	228.00
22328	4 15/16	SAF22628415	7 1/16	19 3/8	21 5/8	4 1/4	24 3/4	6 3/4	1	2 3/4	9 5/8	14 3/16	18	3 1/4	330.00
	5	SAF22628500													
22330	5 3/16	SAF22630503	7 1/2	20 7/8	23 5/8	4 5/8	26 3/4	7 1/8	1	3	9 3/4	14 7/8	18 3/4	3 7/16	375.00
22332	5 7/16	SAF22632507	7 7/8	21 5/8	24 3/8	4 1/2	28	7 1/2	1 1/4	3 1/8	10 3/4	15 11/16	20 1/2	3 5/8	430.00
22334	5 15/16	SAF22634515	8 1/4	22 1/2	25	5	29 1/2	8	1 1/4	3 3/8	11 1/4	16 1/2	22 1/4	3 3/4	515.00
22348	8 15/16	PLB22648K81516	12	32 3/4	33 1/2	9	38 1/4	14 3/4	1 5/8	3 1/2	15 1/2	24	-	-	1,370.00
22356	10 7/16	PLB22656K10716	14	36 3/4	38 1/4	10 3/4	43 3/4	18 1/4	2	5	18	28	-	-	2,262.00

Additional Notes

- Please call 1-866-REXNORD for availability
- Lubrication fitting tap size: for 2 11/16 in and smaller shaft sizes, 1/8 in PT; for all other shaft sizes, 1/4 in PT
- Expansion - is 3/8 in for all shaft sizes
- Drain plug tap size - for 2 11/16 in and smaller shaft sizes, 1/8 in PT; for all other shaft sizes, 1/4 in PT
- Minimum extension of shaft beyond locknut, .06 in for closed end unit
- Dimension "P" is recommended dimension for cap removal

- Multi-labyrinth seals standard
- All shaft sizes available with type D5 Pentac seals except when marked with a "**".
- For the Selection Guide, Load Ratings and Speed Limits, see the Link-Belt Split Housed Spherical Roller Bearings Engineering section on pages 210 - 223.
- Note: Dimensions subject to change. Certified dimensions of ordered material furnished on request.

PLB7800, PLB7800F, PLB7600F

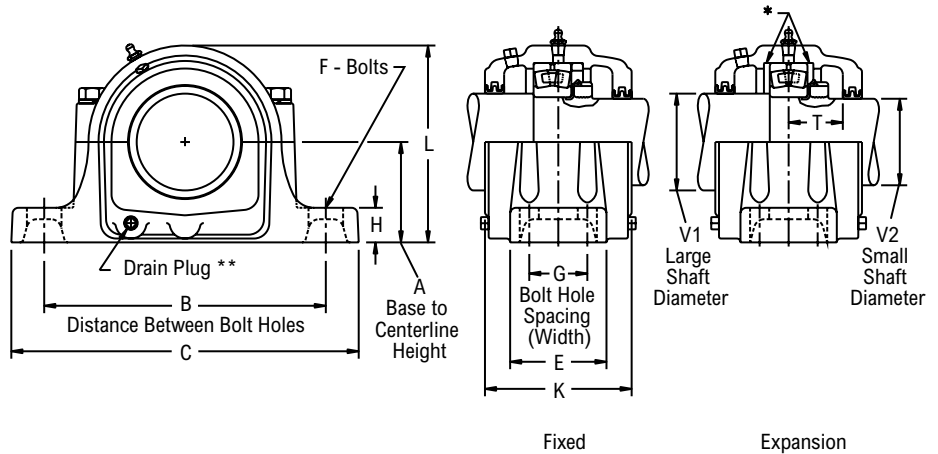
Interchange: USAF 200, SAF22200



Photo Shows a 2-Bolt Spherical Roller Bearing Two-Piece Pillow Block Unit

Product Features

- Corrosion-resistant powder coating
- Two piece cast iron housing
- Fixed or Expansion - up to 3/8 in expansion
- Matched base & cap
- Large reservoir for grease or oil storage
- Direct shaft mounted
- See Features and Benefits for additional info on pages 206 - 207.



Bearing Dimensions

Size Code	Shaft Diameter	V1 Large Shaft Diameter	V2 Small Shaft Diameter	Part Number	A Base to Centerline Height	B Min. Distance Between Bolt Holes	B Max. Distance Between Bolt Holes	G Bolt Hole Spacing (Width)	C	E	F Bolts	H	K	L	P	T	Approx. Weight
Two-Bolt Pillow Block																	
22215	2.95	3 7/16	2 13/16	PLB7875R	3 1/4	8 5/8	9 5/8	-	11 1/4	3 1/8	5/8	1 1/8	4 3/4	6 3/8	8 3/8	1 15/32	35.00
22216	3.15	3 5/8	3	PLB7880R	3 1/2	9 5/8	11	-	13	3 1/2	3/4	1 1/4	5 1/4	7	9 1/2	1 1/2	35.00
22217	3.35	3 15/16	3 3/16	PLB7885R	3 3/4	9 7/8	11	-	13	3 1/2	3/4	1 1/4	5	7 5/16	10	1 19/32	40.00
22218	3.54	4 1/8	3 3/8	PLB7890R	4	10 3/8	11 5/8	-	13 3/4	3 7/8	3/4	1 5/16	5 7/8	7 15/16	10 1/2	1 3/4	42.00
22220	3.94	4 1/2	3 13/16	PLB78100R	4 1/2	11 5/8	13 1/8	-	15 1/4	4 3/8	7/8	1 1/2	6	8 7/8	11 3/4	1 29/32	62.00
Four-Bolt Pillow Block																	
22215	2.95	3 7/16	2 13/16	PLB7875FR	3 1/4	8 5/8	9 5/8	1 7/8	11 1/4	3 1/8	1/2	1 1/8	4 3/4	6 3/8	8 3/8	1 15/32	35.00
22216	3.15	3 5/8	3	PLB7880FR	3 1/2	9 5/8	11	2	13	3 1/2	5/8	1 1/4	5 1/4	7	9 1/2	1 1/2	35.00
22217	3.35	3 15/16	3 3/16	PLB7885FR	3 3/4	9 7/8	11	2	13	3 1/2	5/8	1 1/4	5	7 5/16	10	1 19/32	40.00
22218	3.54	4 1/8	3 3/8	PLB7890FR	4	10 3/8	11 5/8	2 1/8	13 3/4	3 7/8	5/8	1	5 7/8	7 15/16	10 1/2	1 3/4	42.00
22220	3.94	4 1/2	3 13/16	PLB78100FR	4 1/2	11 5/8	13 1/8	2 3/8	15 1/4	4 1/2	3/4	1 1/2	6	8 7/8	11 3/4	1 29/32	62.00
22222	4.33	4 7/8	4 3/16	PLB78110FR	4 15/16	12 5/8	14 1/2	2 3/4	16 1/2	4 3/4	3/4	2	6 1/2	9 5/8	12 1/4	2 1/8	78.00
22224	4.72	5 5/16	4 3/16	PLB78120FR	5 1/4	13 1/4	14 1/2	2 3/4	16 1/2	4 3/4	3/4	1 3/4	7 1/8	10 7/16	13 1/2	2 9/32	102.00
22226	5.12	5 7/8	4 15/16	PLB78130FR	6	14 5/8	16	3 1/4	18 3/8	5 1/8	7/8	2 3/8	7 3/4	11 19/32	14 1/2	2 15/32	141.00
22228	5.51	6 1/4	5 5/16	PLB78140FR	6	16	17 1/8	3 3/8	20 1/8	5 7/8	1	2 3/8	7 3/4	11 13/16	15 1/2	2 5/8	162.00
22230	5.91	6 5/8	5 3/4	PLB78150FR	6 5/16	17	18 1/4	3 3/4	21 1/4	6 1/4	1	2	8 1/8	12 9/16	16	2 3/4	182.00
22232	6.30	7	6 1/16	PLB78160FR	6 11/16	17 3/8	19 1/4	3 3/4	22	6 1/4	1	2 5/8	8 1/2	13 3/8	17	2 31/32	202.00
22234	6.69	7 7/16	6 7/16	PLB78170FR	7 1/16	19 3/8	21 5/8	4 1/4	24 3/4	6 3/4	1	2 3/4	9 1/4	14 1/4	18	3 1/8	240.00
22236	7.09	7 13/16	6 7/8	PLB78180FR	7 1/2	20 7/8	23 5/8	4 5/8	26 3/4	7 1/8	1	3	9 5/8	14 15/16	18 3/4	3 5/32	279.00
22238	7.48	8 3/8	7 1/4	PLB78190FR	7 7/8	21 5/8	24 3/8	4 1/2	28	7 1/2	1 1/4	3 1/8	10 1/4	15 13/16	20 1/2	3 5/16	345.00
22240	7.87	8 3/4	7 5/8	PLB78200FR	8 1/4	22 1/2	25	5	29 1/2	8	1 1/4	2 3/8	11	16 3/4	22 1/4	3 17/32	415.00
22244	8.66	9 9/16	8 5/16	PLB22244	9 1/2	24 3/4	27 7/8	5 1/4	32 3/4	8 3/4	1 1/2	3 3/4	11 7/8	18 5/8	-	-	620.00
				PLB78220FR									11 3/16	18 9/16	24 1/2	3 13/16	
22248	9.45	10 1/2	9 3/16	PLB22248	10 1/4	29	30 1/2	8 3/4	35	14 1/2	1 5/8	3 3/4	14 1/8	20 1/2	-	-	976.00
23048	9.45	10 1/2	9 3/16	PLB76240FR	8 1/4	22 1/2	25	5	29 1/2	8	1 1/4	2 3/8	11	16 3/4	22 1/4	3 13/16	430.00
23056	11.02	12	10 3/4	PLB76280FR	9 1/2	24 3/4	27 7/8	5 1/4	32 3/4	8 3/4	1 1/2	2 3/4	11 3/4	19 1/16	24 1/2	4 1/4	595.00

Additional Notes

- Please call 1-866-REXNORD for availability
- Lubrication fitting tap size: for 3.5433 in (90 mm) and smaller shaft sizes, 1/8 in PT: for all other shaft sizes, 1/4 in PT
- Expansion - is 3/8 in for all shaft sizes
- Drain plug tap size - for 3.5433 in (90 mm) and smaller shaft sizes, 1/8 in PT: for 3.9370 in (100 mm) thru 6.6929 in (170 mm), 1/4 in PT: for all other shaft sizes, 1/2 in PT
- Minimum extension of shaft beyond locknut, .06 in for closed end unit

- Dimension "P" is recommended dimension for cap removal
- Multi-labyrinth seals standard
- For the Selection Guide, Load Ratings and Speed Limits, see the Link-Belt Split Housed Spherical Roller Bearings Engineering section on pages 210 - 223.
- For shaft bearing seat diameters, see Link-Belt Spherical Roller Bearings Shaft & Housing Seat Diameters section on pages 266 - 269.
- Note: Dimensions subject to change. Certified dimensions of ordered material furnished on request.

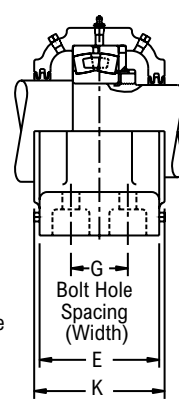
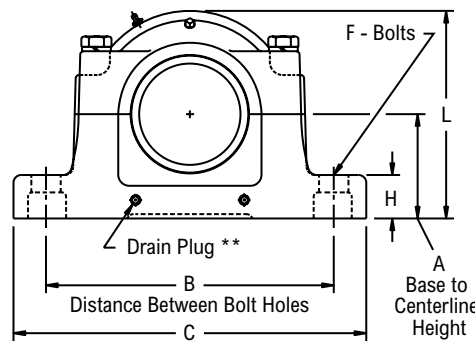
PKLB7800F, PKLB7600F



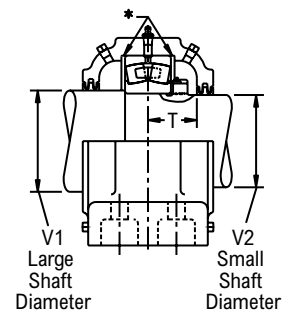
Photo Shows a 4-Bolt Spherical Roller Bearing Two-Piece Pillow Block Unit

Product Features

- Corrosion-resistant powder coating
- Two piece cast steel housing
- Fixed or Expansion - up to 3/8 in expansion
- Matched base & cap
- Large reservoir for grease or oil storage
- Direct shaft mounted
- See Features and Benefits for additional info on pages 206 - 207.



Fixed



Expansion

Bearing Dimensions

Size Code	Shaft Diameter	V1 Large Shaft Diameter	V2 Small Shaft Diameter	Part Number	A Base to Centerline Height	B Min. Distance Between Bolt Holes	B Max. Distance Between Bolt Holes	G Bolt Hole Spacing (Width)	C	E	F Bolts	H	K	L	P	T	Approx. Weight
22215	2.9528	3 ⁷ / ₁₆	2 ¹³ / ₁₆	PKLB7875FR	3 ¹ / ₄	8 ⁵ / ₈	9 ⁵ / ₈	1 ⁷ / ₈	11 ¹ / ₄	4 ³ / ₈	1/2	1 ¹ / ₂	4 ³ / ₄	6 ³ / ₈	10 ¹ / ₄	1 ¹⁵ / ₃₂	35.00
22216	3.1496	3 ⁵ / ₈	3	PKLB7880FR	3 ¹ / ₂	9 ⁵ / ₈	11	2	13	4 ⁷ / ₈	5/8	1 ⁵ / ₈	5 ¹ / ₄	7	11	1 ¹ / ₂	48.00
22217	3.3465	3 ¹⁵ / ₁₆	3 ³ / ₁₆	PKLB7885FR	3 ³ / ₄	9 ⁷ / ₈	11	2	13	4 ⁷ / ₈	5/8	1 ⁵ / ₈	5 ¹ / ₄	7 ³ / ₈	11 ¹ / ₂	1 ¹⁹ / ₃₂	50.00
22220	3.9370	4 ¹ / ₂	3 ¹³ / ₁₆	PKLB78100FR	4 ¹ / ₂	11 ⁵ / ₈	13 ¹ / ₈	2 ³ / ₈	15 ¹ / ₄	6	3/4	1 ⁷ / ₈	6 ¹ / ₂	8 ¹³ / ₁₆	13 ³ / ₄	1 ²⁹ / ₃₂	85.00
22222	4.3307	4 ⁷ / ₈	4 ³ / ₁₆	PKLB78110FR	4 ¹⁵ / ₁₆	12 ⁵ / ₈	14 ¹ / ₂	2 ³ / ₄	16 ¹ / ₂	6 ¹ / ₂	3/4	2	7	9 ³ / ₄	15 ¹ / ₄	2 ¹ / ₈	105.00
22226	5.1181	5 ⁷ / ₈	4 ¹⁵ / ₁₆	PKLB78130FR	6	14 ⁵ / ₈	16	3 ¹ / ₄	18 ³ / ₈	7 ¹ / ₄	7/8	2 ¹ / ₄	7 ³ / ₄	11 ¹ / ₂	18 ¹ / ₄	2 ¹⁵ / ₃₂	187.00
22228	5.5118	6 ¹ / ₄	5 ⁵ / ₁₆	PKLB78140FR	6	16	17 ¹ / ₈	3 ³ / ₈	20 ¹ / ₈	6 ⁷ / ₈	1	2 ¹ / ₂	7 ¹ / ₂	11 ¹⁵ / ₁₆	19 ¹ / ₄	2 ⁵ / ₈	190.00
22232	6.2992	7	6 ¹ / ₁₆	PKLB78160FR	6 ¹¹ / ₁₆	17 ³ / ₈	19 ¹ / ₄	3 ³ / ₄	22	8	1	2 ³ / ₄	8 ¹ / ₂	13 ¹ / ₂	20 ¹ / ₂	2 ³¹ / ₃₂	250.00
22234	6.6929	7 ⁷ / ₁₆	6 ⁷ / ₁₆	PKLB78170FR	7 ¹ / ₁₆	19 ³ / ₈	21 ⁵ / ₈	4 ¹ / ₄	24 ³ / ₄	8 ³ / ₄	1	3	9 ¹ / ₄	14 ¹ / ₄	22 ¹ / ₄	3 ¹ / ₈	344.00
22236	7.0866	7 ¹³ / ₁₆	6 ⁷ / ₈	PKLB78180FR	7 ¹ / ₂	20 ⁷ / ₈	23 ⁵ / ₈	4 ⁵ / ₈	26 ³ / ₄	9 ¹ / ₈	1	3 ¹ / ₄	9 ⁵ / ₈	14 ¹⁵ / ₁₆	23 ¹ / ₄	3 ⁵ / ₃₂	365.00
22238	7.4803	8 ³ / ₈	7 ¹ / ₄	PKLB78190FR	7 ⁷ / ₈	21 ⁵ / ₈	24 ³ / ₈	4 ¹ / ₂	28	9 ³ / ₄	1 ¹ / ₄	3 ¹ / ₄	10 ¹ / ₄	15 ¹³ / ₁₆	25	3 ⁵ / ₁₆	450.00
22244	8.6614	9 ⁹ / ₁₆	8 ⁵ / ₁₆	PKLB78220FR	9 ¹ / ₂	25 ⁵ / ₈	27 ⁷ / ₈	7 ¹ / ₄	32	12	1 ³ / ₄	4	12 ⁵ / ₈	18 ¹¹ / ₁₆	29 ¹ / ₄	3 ¹³ / ₁₆	770.00
23048	9.4488	10 ¹ / ₂	9 ³ / ₁₆	PKLB76240FR	8 ¹ / ₄	22 ¹ / ₂	25	5	29 ¹ / ₂	10 ³ / ₈	1 ¹ / ₄	3 ¹ / ₂	11	16 ¹ / ₂	26 ¹ / ₂	3 ¹³ / ₁₆	530.00
23056	11.0236	12	10 ³ / ₄	PKLB76280FR	9 ¹ / ₂	25 ⁷ / ₈	27 ⁵ / ₈	7 ¹ / ₄	32	12	1 ³ / ₄	4	12 ⁵ / ₈	18 ¹¹ / ₁₆	29 ¹ / ₄	4 ¹ / ₄	745.00

Additional Notes

- Please call 1-866-REXNORD for availability
- Lubrication fitting tap size, 1/4 in PT
- Expansion - is 3/8 in for all shaft sizes
- Drain plug tap size - for 6.6929 in (170 mm) and smaller shaft sizes, 1/4 in PT; for all other shaft sizes, 1/2 in PT
- Minimum extension of shaft beyond locknut, .06 in for closed end unit
- Dimension "P" is recommended dimension for cap removal
- Multi-labyrinth seals standard

For the Selection Guide, Load Ratings and Speed Limits, see the Link-Belt Split Housed Spherical Roller Bearings Engineering section on pages 210 - 223.

For shaft bearing seat diameters, see Link-Belt Spherical Roller Bearings Shaft & Housing Seat Diameters section on pages 266 - 269.

Note: Dimensions subject to change. Certified dimensions of ordered material furnished on request.

PLB7900, PLB7900F, SAF22300

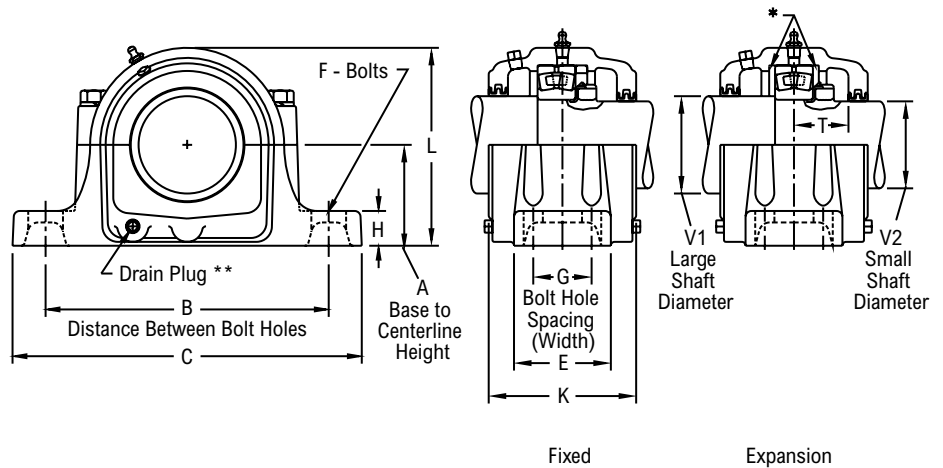
Interchange: USAF 300, SAF22300



Photo Shows a 2-Bolt Spherical Roller Bearing Two-Piece Pillow Block Unit

Product Features

- Corrosion-resistant powder coating
- Two piece cast iron housing
- Fixed or Expansion - up to 3/8 in expansion
- Matched base & cap
- Large reservoir for grease or oil storage
- Direct shaft mounted
- See Features and Benefits for additional info on pages 206 - 207.



Bearing Dimensions

Size Code	Shaft Diameter	V1 Large Shaft Diameter	V2 Small Shaft Diameter	Part Number	A Base to Centerline Height	B Min. Distance Between Bolt Holes	B Max. Distance Between Bolt Holes	G Bolt Hole Spacing (Width)	C	E	F Bolts	H	K	L	P	T	Approx. Weight
Two-Bolt Pillow Block																	
22309	1.77	2 1/8	1 11/16	PLB7945R	2 3/4	7 1/4	8	-	9 5/8	2 3/4	5/8	1	4 1/8	5 3/8	7 1/2	1 5/16	18.00
22310	1.97	2 3/8	1 7/8	PLB7950R	3	7 3/4	9	-	10 5/8	2 3/4	5/8	1 1/8	4 1/2	5 7/8	7 7/8	1 15/32	22.00
22311	2.17	2 9/16	2 1/16	PLB7955R	3 1/4	8 1/8	9 1/2	-	11	3 1/8	5/8	1 3/16	4 3/4	6 5/16	8 1/2	1 9/16	27.00
22313	2.56	3 1/16	2 7/16	PLB7965R	3 1/2	9 5/8	11	-	13	3 1/2	3/4	1 1/4	5 1/4	7	9 5/8	1 23/32	39.00
22315	2.95	3 7/16	2 13/16	PLB7975R	4	10 3/8	11 5/8	-	13 3/4	3 7/8	3/4	1 5/16	5 7/8	7 15/16	10 1/2	1 15/16	50.00
22316	3.15	3 5/8	3	PLB7980R	4 1/4	10 5/8	12 5/8	2 1/8	14 1/4	3 7/8	3/4	1 5/16	6 1/8	8 3/8	11 1/4	2	58.00
22317	3.35	3 15/16	3 3/16	PLB7985R	4 1/2	11 5/8	13 1/8	-	15 1/4	4 3/8	7/8	1 1/2	6 1/2	8 7/8	11 3/4	2 1/2	71.00
Four-Bolt Pillow Block																	
22313	2.56	3 1/16	2 7/16	PLB7965FR	3 1/2	9 5/8	11	2	13	3 1/2	5/8	1 1/4	5 1/4	7	9 5/8	1 23/32	39.00
22315	2.95	3 7/16	2 13/16	PLB7975FR	4	10 3/8	11 5/8	2 1/8	13 3/4	3 7/8	5/8	1 5/16	5 7/8	7 15/16	10 1/2	1 15/16	50.00
22316	3.15	3 5/8	3	PLB7980FR	4 1/4	10 5/8	12 5/8	2 1/8	14 1/4	3 7/8	5/8	1 5/16	6 1/8	8 3/8	11 1/4	2	58.00
22317	3.35	3 15/16	3 3/16	PLB7985FR	4 1/2	11 5/8	13 1/8	2 3/8	15 1/4	4 3/8	3/4	1 1/2	6 1/2	8 7/8	11 3/4	2 1/2	71.00
22318	3.54	4 1/8	3 3/8	SAF22318	4 3/4	12	13 1/2	2 1/4	15 1/2	4 3/8	3/4	2	6 7/8	9 3/16	12 1/4	2 7/32	94.00
22320	3.94	4 1/2	3 13/16	SAF22320	5 1/4	13 1/4	14 1/2	2 3/4	16 1/2	4 3/4	3/4	1 3/4	7 1/8	10 7/16	13 1/2	2 7/16	118.00
22322	4.33	4 7/8	4 3/16	SAF22322	6	14 5/8	16	3 1/4	18 3/8	5 1/8	7/8	1 7/8	7 3/4	11 11/16	14 1/2	2 21/32	147.00
22324	4.72	5 5/16	4 9/16	SAF22324	6 5/16	17	18 1/4	3 3/4	21 1/4	6 1/4	1	2 1/2	8 3/8	12 1/2	16	2 13/16	215.00
22326	5.12	5 7/8	4 15/16	SAF22326	6 11/16	17 3/8	19 1/4	3 3/4	22	6 1/4	1	2 5/8	8 3/4	13 5/16	17	3 5/16	215.00
22328	5.51	6 1/4	5 5/16	SAF22328	7 1/16	19 3/8	21 5/8	4 1/4	24 3/4	6 3/4	1	2 3/4	9 3/8	14 3/16	18	3 1/4	320.00
22330	5.91	6 5/8	5 3/4	SAF22330	7 1/2	20 7/8	23 5/8	4 5/8	26 3/4	7 1/8	1	3	9 3/4	14 7/8	18 3/4	3 7/16	350.00
22332	6.30	7	6 1/16	SAF22332	7 7/8	21 5/8	24 3/8	4 1/2	28	7 1/2	1 1/4	3 1/8	10 3/4	15 11/16	20 1/2	3 5/8	410.00
22334	6.69	7 7/16	6 7/16	SAF22334	8 1/4	22 1/2	25	5	29 1/2	8	1 1/4	3 3/8	11 1/4	16 1/2	22 1/4	3 3/4	485.00
22348	9.45	10 1/2	9 1/16	PLB22348	12	32 3/4	33 1/2	9	38 1/4	14 3/4	1 5/8	3 1/2	15 1/2	24	-	-	1,322.00
22356	11.02	12 3/4	10 3/4	PLB22356	14	36 3/4	38 1/4	10 3/4	43 3/4	18 1/4	2	5	18	28	-	-	2,203.00

Additional Notes

- Please call 1-866-REXNORD for availability
- Lubrication fitting tap size: for 3.1496 in (80 mm) and smaller shaft sizes, 1/8 in PT: for all other shaft sizes, 1/4 in PT
- Expansion - is 3/8 in for all shaft sizes
- Drain plug tap size - for 3.1496 in (80 mm) and smaller shaft sizes, 1/8 in PT: for 3.3465 in (85 mm) thru 4.3307 in (110 mm), 1/4 in PT: for 4.7244 in (120 mm) thru 6.2992 in (160 mm), 3/8 in PT: for all other shaft sizes, 1/2 in PT
- Minimum extension of shaft beyond locknut, .06 in for closed end unit
- Dimension "P" is recommended dimension for cap removal

- Multi-labyrinth seals standard
- SAF pillow blocks include locknut and washer
- For the Selection Guide, Load Ratings and Speed Limits, see the Link-Belt Split Housed Spherical Roller Bearings Engineering section on pages 210 - 223.
- For shaft bearing seat diameters, see Link-Belt Spherical Roller Bearings Shaft & Housing Seat Diameters section on pages 266 - 269.
- Note: Dimensions subject to change. Certified dimensions of ordered material furnished on request.

PLB23000K

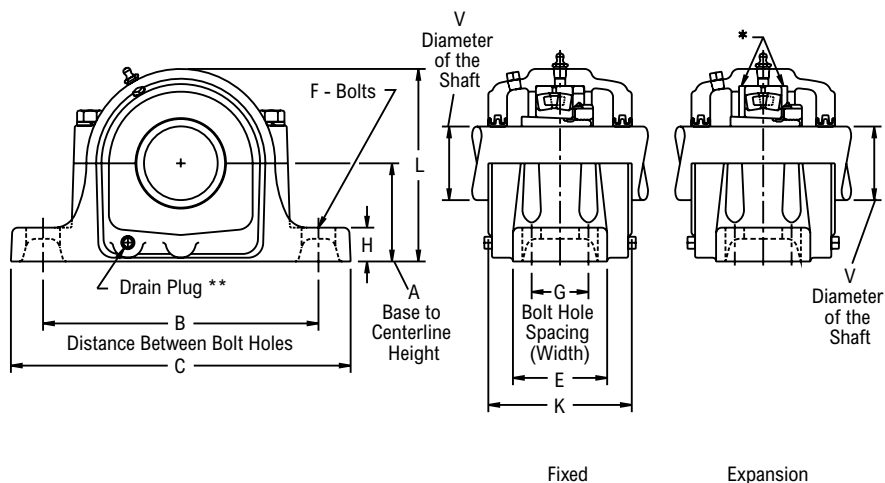
Interchange: USAF 500, USDAF, S(D)AF23000KA, S(D)AF23000K



Photo Shows a 2-Bolt Spherical Roller Bearing Two-Piece Pillow Block Unit

Product Features

- Corrosion-resistant powder coating
- Two piece cast iron housing
- Broad range of sealing options
- Fixed or Expansion - up to 3/8 in expansion
- Matched base & cap
- Large reservoir for grease or oil storage
- Tapered adapter mounted
- See Features and Benefits for additional info on pages 206 - 207.



Bearing Dimensions

Size Code	Shaft Diameter	Part Number	A Base to Centerline Height	B Min. Distance Between Bolt Holes	B Max. Distance Between Bolt Holes	G Bolt Hole Spacing (Width)	C	E	F Bolts	H	K	L	Approx. Weight
Four-Bolt Pillow Block													
23044	7 ¹⁵ / ₁₆	PLB23044K71516	7 ⁷ / ₈	21 ⁵ / ₈	24 ³ / ₈	4 ¹ / ₂	28	7 ¹ / ₂	1 ¹ / ₄	3 ¹ / ₈	10 ³ / ₄	15 ¹¹ / ₁₆	413.00
	8	PLB23044K8											
23048	8 ¹ / ₂	PLB23048K812	8 ¹ / ₄	22 ¹ / ₂	25	5	29 ¹ / ₂	8	1 ¹ / ₄	3 ³ / ₈	11 ¹ / ₈	16 ¹¹ / ₁₆	474.00
	8 ¹⁵ / ₁₆	PLB23048K81516											
	9	PLB23048K9											
23052	9 ⁷ / ₁₆	PLB23052K9716	9 ¹ / ₂	24 ³ / ₄	27 ⁷ / ₈	5 ¹ / ₄	32 ³ / ₄	8 ³ / ₄	1 ¹ / ₂	3 ³ / ₄	11 ⁷ / ₈	18 ¹³ / ₁₆	530.00
	9 ¹ / ₂	PLB23052K912											
23056	9 ¹⁵ / ₁₆	PLB23056K91516	9 ⁷ / ₈	26 ¹ / ₄	29 ¹ / ₂	5 ¹ / ₂	34 ¹ / ₄	9	1 ¹ / ₂	4	12 ¹ / ₁₆	20 ³ / ₁₆	800.00
	10	PLB23056K10											
	10 ⁷ / ₁₆	PLB23056K10716											
23060	10 ¹⁵ / ₁₆	PLB23060K101516	12	32 ³ / ₄	33 ¹ / ₂	9	38 ¹ / ₄	14 ³ / ₄	1 ⁵ / ₈	3 ¹ / ₂	15 ¹ / ₂	24	1,200.00
	11	PLB23060K11											
23064	11 ¹⁵ / ₁₆	PLB23064K111516	12	32 ³ / ₄	33 ¹ / ₂	9	38 ¹ / ₄	15 ¹ / ₈	1 ⁵ / ₈	3 ¹ / ₂	16 ¹ / ₂	24	1,250.00
	12	PLB23064K12											
23068	12 ¹ / ₂	PLB23068K1212	12	32	33 ¹ / ₂	10	39	15 ¹ / ₄	1 ⁷ / ₈	4 ³ / ₁₆	15 ³ / ₄	24	1,550.00
23072	12 ¹⁵ / ₁₆	PLB23072K121516	12 ¹³ / ₁₆	35	36 ¹ / ₂	10 ¹ / ₂	41 ³ / ₄	15 ³ / ₄	1 ⁷ / ₈	4 ¹ / ₂	16 ¹ / ₄	26	1,650.00
	13	PLB23072K13											
23076	13 ¹⁵ / ₁₆	PLB23076K131516	12 ¹³ / ₁₆	35	36 ¹ / ₂	10 ¹ / ₂	41 ³ / ₄	15 ³ / ₄	1 ⁷ / ₈	4 ¹ / ₂	16 ¹ / ₄	26	1,700.00
	14	PLB23076K14											3,245.00
23080	15	PLB23080K15	14 ¹ / ₂	39 ¹ / ₄	40 ³ / ₄	11	46	17 ¹ / ₈	2	5	18	28 ³ / ₄	2,300.00
23084	15 ³ / ₄	PLB23084K1534	14 ¹ / ₂	39 ¹ / ₄	40 ³ / ₄	11	46	17 ¹ / ₈	2	5	18	28 ³ / ₄	2,300.00
23088	16 ¹ / ₂	PLB23088K1612	15 ¹ / ₂	41 ¹ / ₂	43 ¹ / ₂	12 ¹ / ₄	48 ³ / ₄	18 ³ / ₄	2 ¹ / ₄	5 ¹ / ₂	19 ³ / ₈	31	2,550.00
23092	17	PLB23092K17	15 ¹ / ₂	41 ¹ / ₂	43 ¹ / ₂	12 ¹ / ₄	48 ³ / ₄	18 ³ / ₄	2 ¹ / ₄	5 ¹ / ₂	19 ³ / ₈	31	2,850.00
23096	18	PLB23096K18	17	44 ¹ / ₂	46 ⁵ / ₈	14 ¹ / ₂	52 ³ / ₄	22 ¹ / ₄	2 ¹ / ₄	5 ¹ / ₂	21 ³ / ₄	34	4,250.00
230530	19 ¹ / ₂	PLB230530K1912	18	47 ¹ / ₈	48 ⁷ / ₈	15	54 ¹ / ₄	21 ⁵ / ₈	2 ¹ / ₂	5 ³ / ₄	22 ³ / ₄	35 ³ / ₄	5,200.00
230560	21	PLB230560K21	18	47 ¹ / ₈	48 ⁷ / ₈	15	54 ¹ / ₄	21 ⁵ / ₈	2 ¹ / ₂	5 ³ / ₄	22 ³ / ₄	35 ³ / ₄	3,745.00
230600	22	PLB230600K22	20	52 ¹ / ₂	54	16	60	22	3	6	24 ⁵ / ₈	40	5,525.00
230630	24	PLB230630K24	20	52 ¹ / ₂	54	16	60	22	3	6	24 ⁵ / ₈	40	5,356.00

Additional Notes

- Please Call 1-866-REXNORD for availability
- Lubrication Fitting Tap Size, 1/4 in PT
- Expansion is 3/8 in for all shaft sizes
- Multi-labyrinth seals standard
- For the Selection Guide, Load Ratings and Speed Limits, see the Link-Belt Split Housed Spherical Roller Bearings Engineering section on pages 210 - 223.
- Note: Dimensions subject to change. Certified dimensions of ordered material furnished on request.

PLB23100K

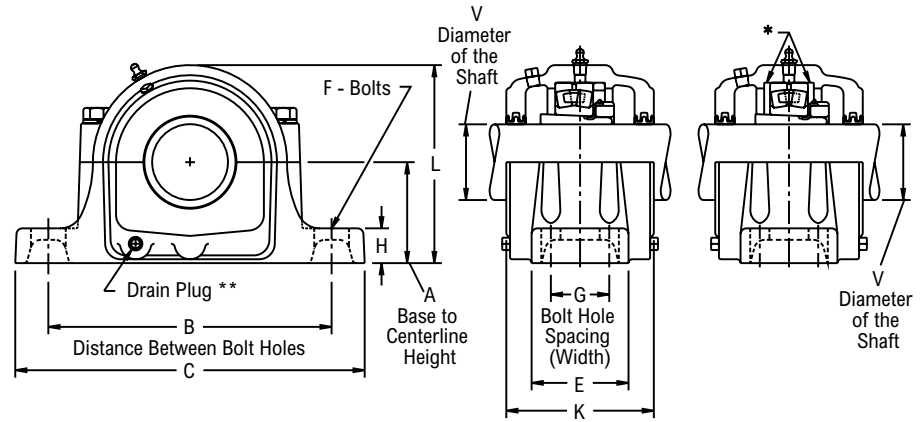
Interchange: USDAF, SDAF23100KA, SDAF23100K



Two-Piece Pillow Block Unit

Product Features

- Corrosion-resistant powder coating
- Two piece cast iron housing
- Broad range of sealing options
- Fixed or Expansion - up to 3/8 in expansion
- Matched base & cap
- Large reservoir for grease or oil storage
- Tapered adapter mounted
- See Features and Benefits for additional info on pages 206 - 207.



Bearing Dimensions

Size Code	Shaft Diameter	Part Number	A Base to Centerline Height	B Min. Distance Between Bolt Holes	B Max. Distance Between Bolt Holes	G Bolt Hole Spacing (Width)	C	E	F Bolts	H	K	L	Approx. Weight
Four-Bolt Pillow Block													
23144	8	PLB23144K8	8 1/4	22 1/2	25	5	29 1/2	8	1 1/4	3 3/8	12 1/8	16 1/2	496.00
23148	8 15/16	PLB23148K81516	9 1/2	24 3/4	27 7/8	5 1/4	32 3/4	8 3/4	1 1/2	3 3/4	13 1/2	18 5/8	820.00
23152	9 7/16	PLB23152K9716	10 1/4	29	30 1/2	8 3/4	35	14 1/2	1 5/8	3 3/4	14 1/8	20 1/2	1,029.00
23156	10 7/16	PLB23156K10716	12	32 3/4	33 1/2	9	38 1/4	14 3/4	1 5/8	3 1/2	15 1/2	24	1,253.00
23160	10 15/16	PLB23160K101516	12	32 3/4	33 1/2	9	38 1/4	15 1/8	1 5/8	3 1/2	16 1/2	24	1,333.00
23164	11 15/16	PLB23164K111516	12 13/16	35	36 1/2	10 1/2	41 3/4	15 3/4	1 7/8	4 1/2	16 1/4	26	1,768.00
23168	12 7/16	PLB23168K12716	14	36 3/4	38 1/4	10 3/4	43 3/4	18 1/4	2	5	18	28	2,265.00
23172	13 7/16	PLB23172K13716	14 1/2	39 1/4	40 3/4	11	46	17 1/8	2	5	18	28 3/4	2,442.00
23176	13 15/16	PLB23176K131516	14 1/2	39 1/4	40 3/4	11	46	17 1/8	2	5	18	28 3/4	2,473.00
23180	15	PLB23180K15	15 1/2	41 1/2	43 1/2	12 1/4	48 3/4	18 3/4	2 1/4	5 1/2	19 3/8	31	3,119.00
23184	15 3/4	PLB23184K1534	17	44 1/2	46 5/8	14 1/2	52 3/4	22 1/4	2 1/4	5 1/2	21 3/4	34	4,039.00
23188	16 1/2	PLB23188K1612	17	44 1/2	46 5/8	14 1/2	52 3/4	22 1/4	2 1/4	5 1/2	21 3/4	34	4,003.00
23192	17	PLB23192K17	18	47 1/8	48 7/8	15	54 1/4	21 5/8	2 1/2	5 3/4	22 3/4	35 3/4	4,600.00
23196	18	PLB23196K18	18	47 1/8	48 7/8	15	54 1/4	21 5/8	2 1/2	5 3/4	22 3/4	35 3/4	4,707.00
231530	19 1/2	PLB231530K1912	20	52 1/2	54	16	60	22	3	6	24 5/8	40	6,002.00
231560	21	PLB231560K21	20	52 1/2	54	16	60	22	3	6	24 5/8	40	5,881.00

Additional Notes

- Please Call 1-866-REXNORD for availability
- Lubrication Fitting Tap Size, 1/4 in PT
- Expansion is 3/8 in for all shaft sizes
- Multi-labyrinth seals standard
- For the Selection Guide, Load Ratings and Speed Limits, see the Link-Belt Split Housed Spherical Roller Bearings Engineering section on pages 210 - 223.
- Note: Dimensions subject to change. Certified dimensions of ordered material furnished on request.

PLB23100

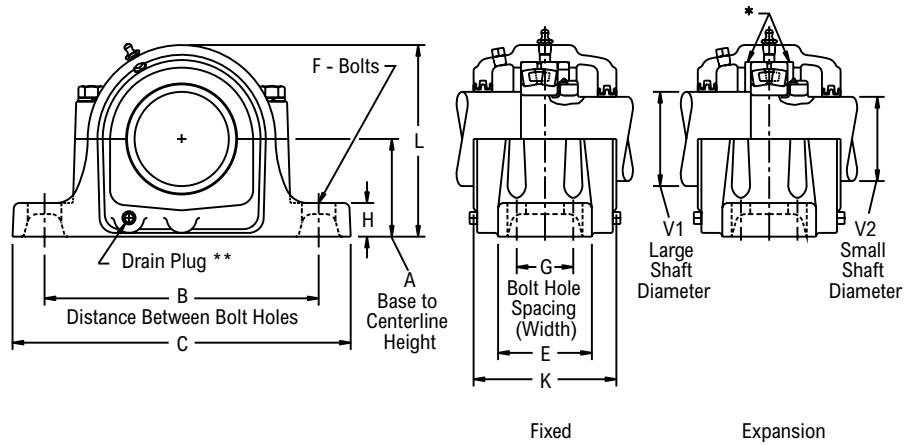
Interchange: USDAF, SDAF23100



Photo Shows a 2-Bolt Spherical Roller Bearing Two-Piece Pillow Block Unit

Product Features

- Corrosion-resistant powder coating
- Two piece cast iron housing
- Fixed or Expansion - up to 3/8 in expansion
- Matched base & cap
- Large reservoir for grease or oil storage
- Direct shaft mounted
- See Features and Benefits for additional info on pages 206 - 207.



Bearing Dimensions

Size Code	Shaft Diameter	V1 Large Shaft Diameter	V2 Small Shaft Diameter	Part Number	A Base to Centerline Height	B Min. Distance Between Bolt Holes	B Max. Distance Between Bolt Holes	G Bolt Hole Spacing (Width)	C	E	F Bolts	H	K	L	Approx. Weight
Four-Bolt Pillow Block															
23152	10.24	11 1/2	9 15/16	PLB23152	10 1/4	29	30 1/2	8 3/4	35	14 1/2	1 5/8	3 3/4	14 1/8	20 1/2	985.00
23156	11.02	12 1/2	10 3/4	PLB23156	12	32 3/4	33 1/2	9	38 1/4	14 3/4	1 5/8	3 1/2	15 1/2	24	1,206.00
23160	11.81	13	11 1/2	PLB23160	12	32 3/4	33 1/2	9	38 1/4	15 1/8	1 5/8	3 1/2	16 1/2	24	1,305.00
23164	12.60	14	12 1/4	PLB23164	12 13/16	35	36 1/2	10 1/2	41 3/4	15 3/4	1 7/8	4 1/2	16 1/4	26	1,504.00
23168	13.39	15	13	PLB23168	14	36 3/4	38 1/4	10 3/4	43 3/4	18 1/4	2	5	18	28	2,172.00
23172	14.17	16	13 3/4	PLB23172	14 1/2	39 1/4	40 3/4	11	46	17 1/8	2	5	18	28 3/4	2,322.00
23176	14.96	17	14 1/2	PLB23176	14 1/2	39 1/4	40 3/4	11	46	17 1/8	2	5	18	28 3/4	2,348.00
23180	15.75	17 1/2	15 1/4	PLB23180	15 1/2	41 1/2	43 1/2	12 1/4	48 3/4	18 3/4	2 1/4	5 1/2	19 3/8	31	2,979.00
23184	16.54	18 1/2	15 3/4	PLB23184	17	44 1/2	46 5/8	14 1/2	52 3/4	22 1/4	2 1/4	5 1/2	21 3/4	34	3,894.00
23188	17.32	19 1/2	17	PLB23188	17	44 1/2	46 5/8	14 1/2	52 3/4	22 1/4	2 1/4	5 1/2	21 3/4	34	3,852.00
23192	18.11	20	17 3/4	PLB23192	18	47 1/8	48 7/8	15	54 1/4	21 5/8	2 1/2	5 3/4	22 3/4	35 3/4	4,391.00

Additional Notes

- Please Call 1-866-REXNORD for availability
- Lubrication Fitting Tap Size, 1/4 in PT
- Expansion is 3/8 in for all shaft sizes
- Multi-labyrinth seals standard
- For the Selection Guide, Load Ratings and Speed Limits, see the Link-Belt Split Housed Spherical Roller Bearings Engineering section on pages 210 - 223.
- Note: Dimensions subject to change. Certified dimensions of ordered material furnished on request.

PLB23200K

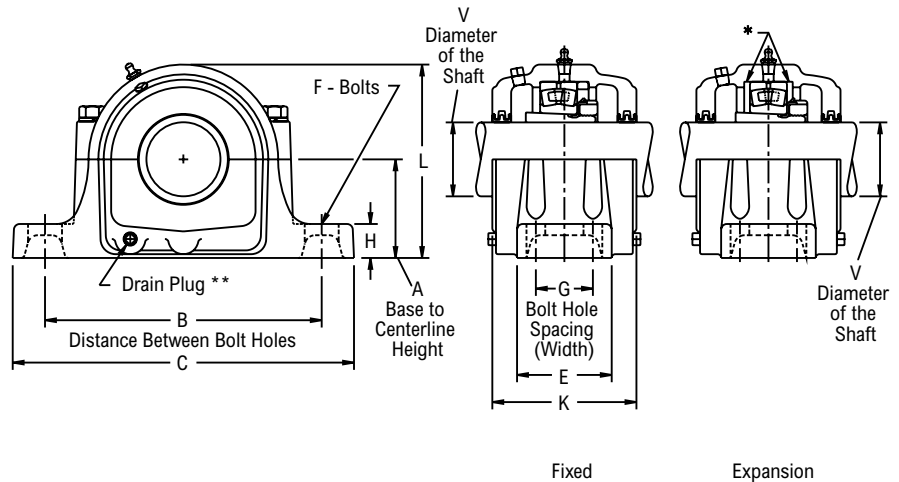
Interchange: USDAF, SDAF23200KA, SDAF23200K



Photo Shows a 2-Bolt Spherical Roller Bearing Two-Piece Pillow Block Unit

Product Features

- Corrosion-resistant powder coating
- Two piece cast iron housing
- Broad range of sealing options
- Fixed or Expansion - up to 3/8 in expansion
- Matched base & cap
- Large reservoir for grease or oil storage
- Tapered adapter mounted
- See Features and Benefits for additional info on pages 206 - 207.



Bearing Dimensions

Size Code	Shaft Diameter	Part Number	A Base to Centerline Height	B Min. Distance Between Bolt Holes	B Max. Distance Between Bolt Holes	G Bolt Hole Spacing (Width)	C	E	F Bolts	H	K	L	Approx. Weight
Four-Bolt Pillow Block													
23244	8	PLB23244K8	9 1/2	24 3/4	27 7/8	5 1/4	32 3/4	8 3/4	1 1/2	3 3/4	13 1/8	18 5/8	712.00
23248	8 15/16	PLB23248K81516	10 1/4	29	30 1/2	8 3/4	35	14 1/2	1 5/8	3 3/4	14 1/8	20 1/2	1,080.00
23252	9 7/16	PLB23252K9716	12	32 3/4	33 1/2	9	38 1/4	15 1/8	1 5/8	3 1/2	16 1/2	24	1,301.00
23256	10 7/16	PLB23256K10716	12	32 3/4	33 1/2	9	38 1/4	15 1/8	1 5/8	3 1/2	16 1/2	24	1,400.00
23260	10 15/16	PLB23260K101516	12 13/16	35	36 1/2	10 1/2	41 3/4	15 3/4	1 7/8	4 1/2	16 1/4	26	1,822.00
23264	11 15/16	PLB23264K111516	14	36 3/4	38 1/4	10 3/4	43 3/4	18 1/4	2	5	18	28	2,173.00
23268	12 7/16	PLB23268K12716	14 1/2	39 1/4	40 3/4	11	46	17 1/8	2	5	18	28 3/4	2,582.00
23272	13 7/16	PLB23272K13716	15 1/2	41 1/2	43 1/2	12 1/4	48 3/4	18 3/4	2 1/4	5 1/2	19 3/8	31	3,278.00
23276	13 15/16	PLB23276K131516	15 1/2	41 1/2	43 1/2	12 1/4	48 3/4	18 3/4	2 1/4	5 1/2	19 3/8	31	3,245.00
23280	15	PLB23280K15	17	44 1/2	46 5/8	14 1/2	52 3/4	22 1/4	2 1/4	5 1/2	21 3/4	34	4,297.00
23284	15 3/4	PLB23284K1534	18	47 1/8	48 7/8	15	54 1/4	21 5/8	2 1/2	5 3/4	22 3/4	35 3/4	4,800.00
23288	16 1/2	PLB23288K1612	18	47 1/8	48 7/8	15	54 1/4	21 5/8	2 1/2	5 3/4	22 3/4	35 3/4	4,798.00
23292	17	PLB23292K17	18	47 1/8	48 7/8	15	54 1/4	21 5/8	2 1/2	5 3/4	22 3/4	35 3/4	4,461.00
23296	18	PLB23296K18	20	52 1/2	54	16	60	22	3	6	24 5/8	40	6,362.00

Additional Notes

- Please Call 1-866-REXNORD for availability
- Lubrication Fitting Tap Size, 1/4 in PT
- Expansion is 3/8 in for all shaft sizes
- Multi-labyrinth seals standard
- For the Selection Guide, Load Ratings and Speed Limits, see the Link-Belt Split Housed Spherical Roller Bearings Engineering section on pages 210 - 223.
- Note: Dimensions subject to change. Certified dimensions of ordered material furnished on request.

PLB23200

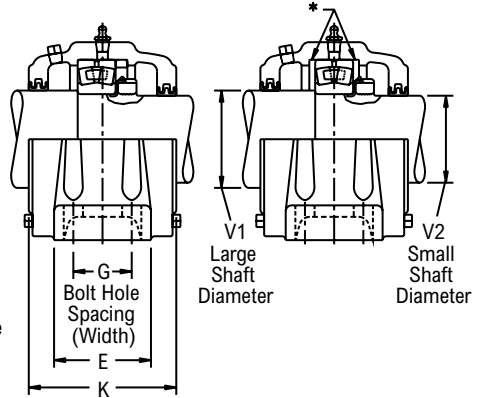
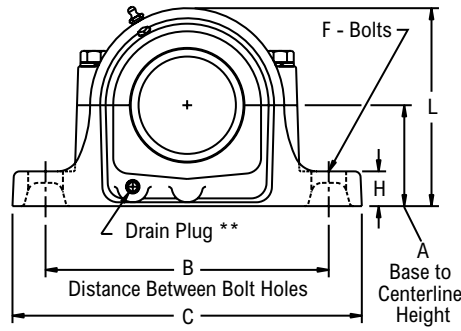
Interchange: USDAF, SDAF23200



Photo Shows a 2-Bolt Spherical Roller Bearing Two-Piece Pillow Block Unit

Product Features

- Corrosion-resistant powder coating
- Two piece cast iron housing
- Fixed or Expansion - up to 3/8 in expansion
- Matched base & cap
- Large reservoir for grease or oil storage
- Direct shaft mounted
- See Features and Benefits for additional info on pages 206 - 207.



Fixed

Expansion

Bearing Dimensions

Size Code	Shaft Diameter	V1 Large Shaft Diameter	V2 Small Shaft Diameter	Part Number	A Base to Centerline Height	B Min. Distance Between Bolt Holes	B Max. Distance Between Bolt Holes	G Bolt Hole Spacing (Width)	C	E	F Bolts	H	K	L	Approx. Weight
Four-Bolt Pillow Block															
23248	9.45	10 1/2	9 3/16	PLB23248	10 1/4	29	30 1/2	8 3/4	35	14 1/2	1 5/8	3 3/4	14 1/8	20 1/2	1,032.00
23252	10.24	11 1/2	9 15/16	PLB23252	12	32 3/4	33 1/2	9	38 1/4	15 1/8	1 5/8	3 1/2	16 1/2	24	1,247.00
23256	11.02	12 1/2	10 3/4	PLB23256	12	32 3/4	33 1/2	9	38 1/4	15 1/8	1 5/8	3 1/2	16 1/2	24	1,400.00
23260	11.81	13	11 1/2	PLB23260	12 13/16	35	36 1/2	10 1/2	41 3/4	15 3/4	1 7/8	4 1/2	16 1/4	26	1,754.00
23264	12.60	14	12 1/4	PLB23264	14	36 3/4	38 1/4	10 3/4	43 3/4	18 1/4	2	5	18	28	2,243.00
23268	13.39	15	13	PLB23268	14 1/2	39 1/4	40 3/4	11	46	17 1/8	2	5	18	28 3/4	2,492.00
23272	14.17	16	13 3/4	PLB23272	15 1/2	41 1/2	43 1/2	12 1/4	48 3/4	18 3/4	2 1/4	5 1/2	19 3/8	31	3,143.00
23276	14.96	17	14 1/2	PLB23276	15 1/2	41 1/2	43 1/2	12 1/4	48 3/4	18 3/4	2 1/4	5 1/2	19 3/8	31	3,100.00
23280	15.75	17 1/2	15 1/4	PLB23280	17	44 1/2	46 5/8	14 1/2	52 3/4	22 1/4	2 1/4	5 1/2	21 3/4	34	4,132.00
23284	16.54	18 1/2	15 3/4	PLB23284	18	47 1/8	48 7/8	15	54 1/4	21 5/8	2 1/2	5 3/4	22 3/4	35 3/4	4,636.00
23288	17.32	19 1/2	17	PLB23288	18	47 1/8	48 7/8	15	54 1/4	21 5/8	2 1/2	5 3/4	22 3/4	35 3/4	4,608.00
23292	18.11	20	17 3/4	PLB23292	18	47 1/8	48 7/8	15	54 1/4	21 5/8	2 1/2	5 3/4	22 3/4	35 3/4	4,461.00

Additional Notes

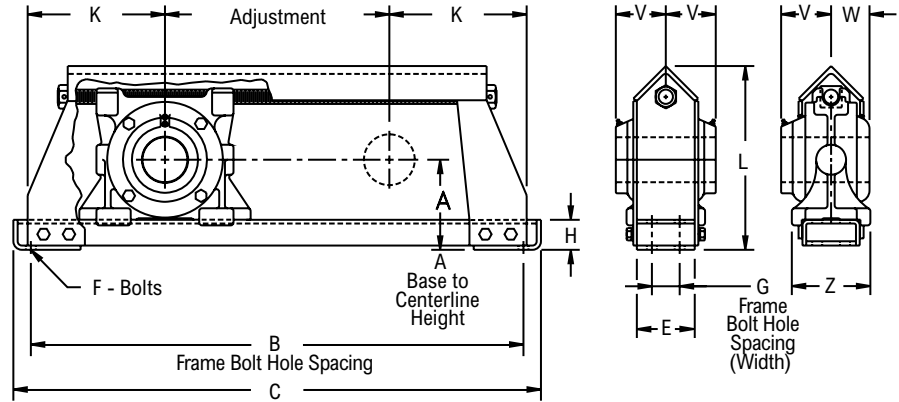
- Please Call 1-866-REXNORD for availability
- Lubrication Fitting Tap Size, 1/4 in PT
- Expansion is 3/8 in for all shaft sizes
- Multi-labyrinth seals standard
- For the Selection Guide, Load Ratings and Speed Limits, see the Link-Belt Split Housed Spherical Roller Bearings Engineering section on pages 210 - 223.
- Note: Dimensions subject to change. Certified dimensions of ordered material furnished on request.



Photo Shows a Hinged Top, Welded Steel Conveyor Take-Up Frame with Spherical Roller Bearing Take-Up Unit

Product Features

- Protected screw type frame
- Corrosion-resistant powder coating
- Cast iron housing
- Independently flushable D8 seals
- Tapered adapter mounted
- See Features and Benefits for additional info on pages 206 - 207.



Bearing Dimensions

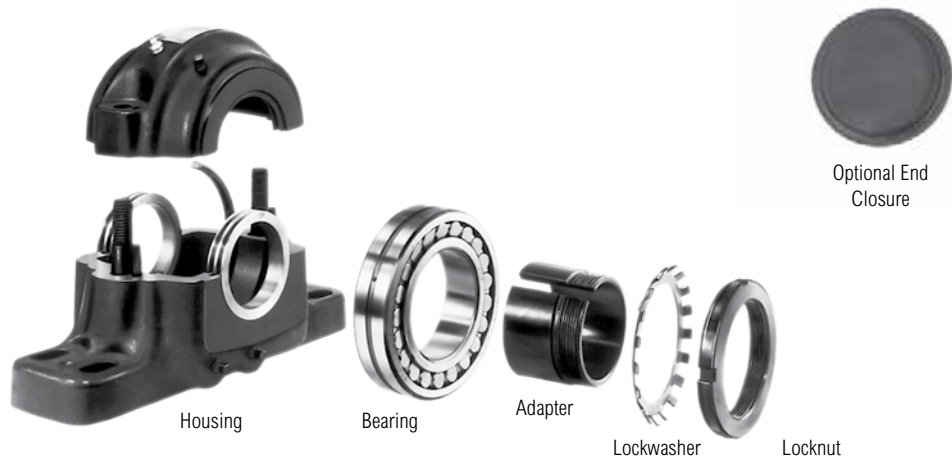
Size Code	Shaft Diameter	Adjust.	Part Number	A Base to Centerline Height	B Frame Bolt Hole Spacing	G Frame Bolt Hole Spacing (Width)	C	E	F Bolts	H	K	L	V	W	Z	Approx. Weight
22215	2 7/16	12	DSLB683912	5 1/8	30 1/2	2	32 1/2	4	5/8	2	9 1/4	10 7/8	3 15/32	2 19/32	5 5/8	94.00
		18	DSLB683918		36 1/2		38 1/2									103.00
		24	DSLB683924		42 1/2		44 1/2									111.00
		30	DSLB683930		48 1/2		50 1/2									119.00
22217	2 15/16	12	DSLB684712	5 5/8	32	2	34 1/4	4	3/4	2	10	11 13/16	3 1/2	2 5/8	5 5/8	120.00
		18	DSLB684718		38		40 1/4									130.00
		24	DSLB684724		44		46 1/4									145.00
		30	DSLB684730		50		52 1/4									155.00
22220	3 7/16	12	DSLB685512	7	36	2 1/2	38 1/2	5	3/4	2 1/4	12	14 11/16	4 1/8	3 1/4	6 7/8	206.00
		18	DSLB685518		42		44 1/2									218.00
		24	DSLB685524		48		50 1/2									230.00
		30	DSLB685530		54		56 1/2									242.00
22222	3 15/16	12	DSLB686312	7 1/2	36	2 1/2	38 1/2	5	3/4	2 1/4	12	15 11/16	4 3/8	3 1/2	6 7/8	255.00
		18	DSLB686318		42		44 1/2									270.00
		24	DSLB686324		48		50 1/2									285.00
		30	DSLB686330		54		56 1/2									300.00
22226	4 7/16	18	DSLB687118	10	47	3	50 1/2	6	7/8	4	14 1/2	20 1/4	4 7/8	3 3/4	7 7/8	414.00
		24	DSLB687124		53		56 1/2									432.00
		30	DSLB687130		59		62 1/2									450.00
22228	4 15/16	18	DSLB687918	10 1/2	49	3	52 1/2	6	1	4	15 1/2	21 1/8	4 3/4	3 27/32	7 7/8	475.00
		24	DSLB687924		55		58 1/2									494.00
		30	DSLB687930		61		64 1/2									515.00
22234	5 15/16	18	DSLB689518	12 1/8	55 7/8	3 3/4	60 1/4	7 1/2	1 1/4	4	18 15/16	25 1/2	5 33/64	4 1/2	9 7/8	708.00
		24	DSLB689524		61 7/8		66 1/4									726.00
		30	DSLB689530		67 7/8		72 1/4									746.00
		42	DSLB689542		79 7/8		84 1/4									784.00

Additional Notes

- Please call 1-866-REXNORD for availability
- Expansion - is 3/8 in for all shaft sizes
- For shaft sizes 2 7/16 in thru 2 15/16 in, frame has removable top construction
- Frames with adjustment of 18" or more have center supporting pad welded to bottom of frame
- Taconite seals standard

For the Selection Guide, Load Ratings and Speed Limits, see the Link-Belt Split Housed Spherical Roller Bearings Engineering section on pages 210 - 223.
 Note: Dimensions subject to change. Certified dimensions of ordered material furnished on request.

PLB6600, PLB6800, PLB66M00, PLB68M00 Spherical Roller Bearing Unit Replacement Parts



Shaft Diameter	Pillow Block	Spherical Roller Bearing	Labyrinth Seal	Adapter Assembly	C-Spacer Ring	End Closure	2-Bolt Cast Iron Adapter Housing	4-Bolt Cast Iron Adapter Housing
	Part Number	Part Number	Part Number	Part Number	Part Number	Part Number	Part Number	Part Number
1 7/16	PLB6823R	22209LBKC3	LB69233R	H309023	68244	LB69246R	PLB6823R02	-
1 1/2	PLB6824R	22209LBKC3	LB69243R	H309024	68244	LB69246R	PLB6824R02	-
1 11/16	PLB6827R	22210LBKC3	LB69273R	H310027	68284	LB69286R	PLB6827R02	-
1 3/4	PLB6828R	22210LBKC3	LB69283R	H310028	68284	LB69286R	PLB6828R02	-
1 15/16	PLB6831R	22211LBKC3	LB69313RA	H311031	69244	LB69326R	PLB6831R02	-
2	PLB6832R	22211LBKC3	LB69323R	H311032	69244	LB69326R	PLB6832R02	-
2 3/16	PLB6835R	22213LBKC3	LB69353RA	H313035	69324	LB69366R	PLB6835R02	-
2 7/16	PLB6839R*	22215LBKC3	LB68393RA	H315039	68404	LB68406R	PLB6839R02	-
2 11/16	PLB6843R*	22216LBKC3	LB68433RA	H316043	68444	LB68446R	PLB6843R02	-
2 15/16	PLB6847R*	22217LBKC3	LB68473RA	H317047	68484	LB68486R	PLB6847R02	-
3	PLB6848R*	22217LBKC3	LB68483R	H317048	68484	LB68486R	PLB6848R02	-
3 3/16	PLB6851R*	22218LBKC3	LB68513R	H318051	68524	LB68526R	PLB6851R02	-
3 7/16	PLB6855R*	22220LBKC3	LB68553RA	H320055	68564	LB68566R	PLB6855R02	-
3 1/2	PLB6856R*	22220LBKC3	LB68563R	H320056	68564	LB68566R	PLB6856R02	-
3 11/16	PLB6859FR	22222LBKC3	LB68593R	H322059	68644	LB68646R	-	PLB6859FR02
3 15/16	PLB6863FR	22222LBKC3	LB68633RA	H322063	68644	LB68646R	-	PLB6863FR02
4	PLB6864FR	22222LBKC3	LB68643R	H322064	68644	LB68646R	-	PLB6864FR02
4 3/16	PLB6867FR	22224LBKC3	LB68673R	H3124067	68684	LB68686R	-	PLB6867FR02
4 7/16	PLB6871FR	22226LBKC3	LB68713RA	H3126071	68724	LB68726R	-	PLB6871FR02
4 1/2	PLB6872FR	22226LBKC3	LB68723R	H3126072	68724	LB68726R	-	PLB6872FR02
4 15/16	PLB6879FR	22228LBKC3	LB68793R	H3128079	68804	LB68806R	-	PLB6879FR02
5	PLB6880FR	22228LBKC3	LB68803R	H3128080	68804	LB68806R	-	PLB6880FR02
5 3/16	PLB6883FR	22230LBKC3	LB68833R	H3130083	68844	LB68846R	-	PLB6883FR02
5 7/16	PLB6887FR	22232LBKC3	LB68873R	H3132087	68924	LB68886R	-	PLB6887FR02
5 15/16	PLB6895FR	22234LBKC3	LB68953R	H3134095	68964	LB68966R	-	PLB6895FR02
6	PLB6896FR	22234LBKC3	LB68963R	H3134096	68964	LB68966R	-	PLB6896FR02
6 7/16	PLB68103FR	22236LBKC3	LB681033R	H3136103	681044	LB681046R	-	PLB68103FR02
6 1/2	PLB68104FR	22236LBKC3	LB681043R	H3136104	681044	LB681046R	-	PLB68104FR02
6 15/16	PLB68111FR	22238LBKC3	LB681113R	H3138111	681124	LB681126R	-	PLB68111FR02
7	PLB68112FR	22238LBKC3	LB681123R	H3138112	681124	LB681126R	-	PLB68112FR02
7 3/16	PLB68115FR	22240LBKC3	LB681153R	H3140115	681164	LB681166R	-	PLB68115FR02
7 1/2	PLB68120FR	22244LBKC3	LB681203R	H3144120	681284	LB681286R	-	PLB68120FR02
7 15/16	PLB68127FR	22244LBKC3	LB681273R	H3144127	681284	LB681286R	-	PLB68127FR02
8	PLB68128FR	22244LBKC3	LB681283R	SNW448	681284	LB681286R	-	PLB68128FR02

Continued...

Continued...

Bearing Dimensions

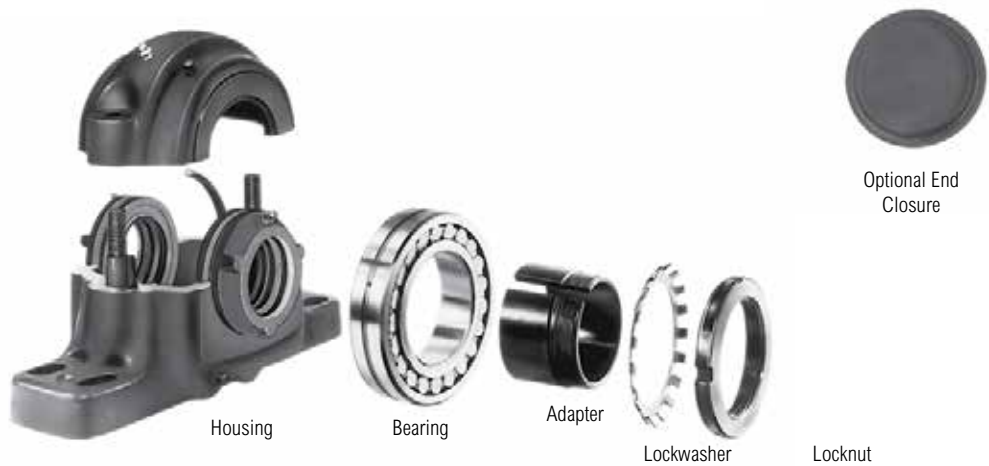
Shaft Diameter	Pillow Block	SpRerical Roller Bearing	LabyrintR Seal	Adapter Assembly	C-Spacer Ring	End Closure	2-Bolt Cast Iron Adapter Rousing	4-Bolt Cast Iron Adapter Rousing
	Part Number	Part Number	Part Number	Part Number	Part Number	Part Number	Part Number	Part Number
8 7/16	PLB66135FR	23048LBKC3	LB661353R	SNP30488716	661444	LB661446	-	PLB66135FR02
8 1/2	PLB66136FR	23048LBKC3	LB661363R	SNP3048812	661444	LB661446	-	PLB66136FR02
9	PLB66144FR	23048LBKC3	LB661443R	SNP30489	661444	LB661446	-	PLB66144FR02
9 7/16	PLB66B151FR	23056LBKC3	LB66B1513R	SNP30569716	661684	LB661686	-	PLB66B151FR02
9 1/2	PLB66B152FR	23056LBKC3	LB66B1523R	SNP3056912	661684	LB661686	-	PLB66B152FR02
9 15/16	PLB66159FR	23056LBKC3	LB661593R	SNP305691516	661684	LB661686	-	PLB66159FR02
10	PLB66160FR	23056LBKC3	LB661603R	SNP305610	661684	LB661686	-	PLB66160FR02
10 7/16	PLB66167FR	23056LBKC3	LB661673R	SNP305610716	661684	LB661686	-	PLB66167FR02
10 1/2	PLB66168FR	23056LBKC3	LB661683R	SNP30561012	661684	LB661686	-	PLB66168FR02
40.00	PLB68M40R	22209LBKC3	LB69M403R	H309	68244	LB69246R	PLB68M40R02	-
45.00	PLB68M45R	22210LBKC3	LB69M453R	H310	68284	LB69286R	PLB68M45R02	-
50.00	PLB68M50R	22211LBKC3	LB69M503R	H311	69244	LB69326R	PLB68M50R02	-
60.00	PLB68M60R	22213LBKC3	LB69M603R	H313	69324	LB69M606R	PLB68M60R02	-
65.00	PLB68M65R*	22215LBKC3	LB68M653R	H315	68404	LB68M656R	PLB68M65R02	-
70.00	PLB68M70R*	22216LBKC3	LB68M703R	H316	68444	LB68446R	PLB68M70R02	-
75.00	PLB68M75R*	22217LBKC3	LB68M753R	H317	68484	LB68486R	PLB68M75R02	-
80.00	PLB68M80R*	22218LBKC3	LB68M803R	H318	68524	LB68526R	PLB68M80R02	-
90.00	PLB68M90R*	22220LBKC3	LB68M903R	H320	68564	LB68566R	PLB68M90R02	-
100.00	PLB68M100FR	22222LBKC3	LB68633R	H322	68644	LB68646R	-	PLB68M100FR02
110.00	PLB68M110FR	22224LBKC3	LB68M1103R	H3124	68684	LB68686R	-	PLB68M110FR02
115.00	PLB68M115FR	22226LBKC3	LB68M1153R	H3126	68724	LB68726R	-	PLB68M115FR02
125.00	PLB68M125FR	22228LBKC3	LB68M1253R	H3128	68804	LB68806R	-	PLB68M125FR02
135.00	PLB68M135FR	22230LBKC3	LB68M1353R	H3130	68844	LB68846R	-	PLB68M135FR02
140.00	PLB68M140FR	22232LBKC3	LB68M1403R	H3132	68924	LB68886R	-	PLB68M140FR02
150.00	PLB68M150FR	22234LBKC3	LB68M1503R	H3134	68964	LB68966R	-	PLB68M150FR02
160.00	PLB68M160FR	22236LBKC3	LB68M1603R	H3136	681044	LB681046R	-	PLB68M160FR02
170.00	PLB68M170FR	22238LBKC3	LB68M1703R	H3138	681124	LB681126R	-	PLB68M170FR02
180.00	PLB68M180FR	22240LBKC3	LB68M1803R	H3140	681164	LB681166R	-	PLB68M180FR02
200.00	PLB68M200FR	22244LBKC3	LB68M2003R	H3144	681284	LB681286R	-	PLB68M200FR02
220.00	PLB66M220FR	23048LBKC3	LB66M2203R	H3048	661444	LB661446	-	PLB66M220FR02
260.00	PLB66M260FR	23056LBKC3	LB66M2603R	H3056	661684	LB661686	-	PLB66M260FR02

Additional Notes

*2-bolt base listed. For 4-bolt base add suffix F; i.e. PLB6839FR Pillow Block or PLB6839FR02 housing.

Housing part numbers listed above include seals and C-Spacer ring.

PLB6600D8, PLB6800D8 Spherical Roller Bearing Unit Replacement Parts



Bearing Dimensions

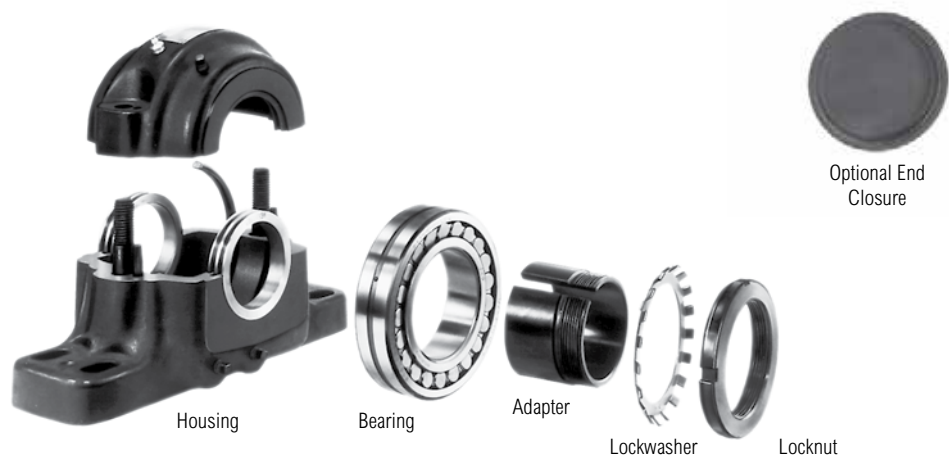
Shaft Diameter	Pillow Block	Spherical Roller Bearing	D8 Seal	Adapter Assembly	C-Spacer	End Closure	2-Bolt Cast Iron Adapter Mounted Housing	4-Bolt Cast Iron Adapter Mounted Housing
	Part Number	Part Number	Part Number	Part Number	Part Number	Part Number	Part Number	Part Number
1 7/16	PLB6823D8	22209LBKC3	LB6923D8	H309023	68244	LB6924D86	PLB6823D802	-
1 1/2	PLB6824D8	22209LBKC3	LB6924D8	H309024	68244	LB6924D86	PLB6824D802	-
1 11/16	PLB6827D8	22210LBKC3	LB6927D8	H310027	68284	LB6928D86	PLB6827D802	-
1 15/16	PLB6831D8	22211LBKC3	LB6931D8	H311031	69244	LB6932D86	PLB6831D802	-
2	PLB6832D8	22211LBKC3	LB6932D8	H311032	69244	LB6932D86	PLB6832D802	-
2 3/16	PLB6835D8	22213LBKC3	LB6935D8	H313035	69324	LB6936D86	PLB6835D802	-
2 7/16	PLB6839D8*	22215LBKC3	LB6839D8	H315039	68404	LB6840D86	PLB6839D802	-
2 11/16	PLB6843D8*	22216LBKC3	LB6843D8	H316043	68444	LB6844D86	PLB6843D802	-
2 15/16	PLB6847D8*	22217LBKC3	LB6847D8	H317047	68484	LB6848D86	PLB6847D802	-
3	PLB6848D8*	22217LBKC3	LB6848D8	H317048	68484	LB6848D86	PLB6848D802	-
3 3/16	PLB6851D8*	22218LBKC3	LB6851D8	H318051	68524	LB6852D86	PLB6851D802	-
3 7/16	PLB6855D8*	22220LBKC3	LB6855D8	H320055	68564	LB6856D86	PLB6855D802	-
3 11/16	PLB6859FD8	22222LBKC3	LB6859D8	H322059	68644	LB6868D86	-	PLB6859FD802
3 15/16	PLB6863FD8	22222LBKC3	LB6863D8	H322063	68644	LB6868D86	-	PLB6863FD802
4 3/16	PLB6867FD8	22224LBKC3	LB6867D8	H3124067	68684	LB6868D86	-	PLB6867FD802
4 7/16	PLB6871FD8	22226LBKC3	LB6871D8	H3126071	68724	LB6880D86	-	PLB6871FD802
4 15/16	PLB6879FD8	22228LBKC3	LB6879D8	H3128079	68804	LB6880D86	-	PLB6879FD802
5 7/16	PLB6887FD8	22232LBKC3	LB6887D8	H3132087	68924	LB6888D86	-	PLB6887FD802
5 15/16	PLB6895FD8	22234LBKC3	LB6895D8	H3134095	68964	LB68104D86	-	PLB6895FD802
6	PLB6896FD8	22234LBKC3	LB6896D8	H3134096	68964	LB68104D86	-	PLB6896FD802
6 7/16	PLB68103FD8	22236LBKC3	LB68103D8	H3136103	681044	LB68104D86	-	PLB68103FD802
6 1/2	PLB68104FD8	22236LBKC3	LB68104D8	H3136104	681044	LB68104D86	-	PLB68104FD802
6 15/16	PLB68111FD8	22238LBKC3	LB68111D8	H3138111	681124	LB68112D86	-	PLB68111FD802
7	PLB68112FD8	22238LBKC3	LB68112D8	H3138112	681124	LB68112D86	-	PLB68112FD802
7 1/2	PLB68120FD8	22244LBKC3	LB68120D8	H3144120	681284	LB68128D86	-	PLB68120FD802
7 15/16	PLB68127FD8	22244LBKC3	LB68127D8	H3144127	681284	LB68128D86	-	PLB68127FD802
8	PLB68128FD8	22244LBKC3	LB68128D8	SNW448	681284	LB68128D86	-	PLB68128FD802
8 7/16	PLB66135FD8	23048LBKC3	LB66135D8	SNP30488716	661444	LB66144D86	-	PLB66135FD802
8 1/2	PLB66136FD8	23048LBKC3	LB66136D8	SNP3048812	661444	LB66144D86	-	PLB66136FD802
9	PLB66144FD8	23048LBKC3	LB66144D8	SNP30489	661444	LB66144D86	-	PLB66144FD802
9 1/2	PLB66B152FD8	23056LBKC3	LB66152D8	SNP3056912	661684	LB66168D86	-	PLB66B152FD802
10 1/2	PLB66168FD8	23056LBKC3	LB66168D8	SNP30561012	661684	LB66168D86	-	PLB66168FD802

Additional Notes

*2-bolt base listed. For 4-bolt base add suffix F; i.e. PLB6839FD8 Pillow Block or PLB6839FD802 housing.

Housing part numbers listed above include seals and C-Spacer ring.

PLB6900, SAF22600 Spherical Roller Bearing Unit Replacement Parts



Bearing Dimensions

Shaft Diameter	Pillow Block	Spherical Roller Bearing	Multi-Labyrinth Seal Type R	Adapter Assembly	C-Spacer	End Closure	2-Bolt Cast Iron Adapter Mounted Housing	4-Bolt Cast Iron Adapter Mounted Housing
	Part Number	Part Number	Part Number	Part Number	Part Number	Part Number	Part Number	Part Number
1 7/16	PLB6923R	22309LBKC3	LB69233R	H2309023	69244	LB69246R	PLB6923R02	-
1 1/2	PLB6924R	22309LBKC3	LB69243R	SNW109112	69244	LB69246R	PLB6924R02	-
1 11/16	PLB6927R	22310LBKC3	LB69273R	H2310027	69284	LB69286R	PLB6927R02	-
1 15/16	PLB6931R	22311LBKC3	LB69313RA	SNW11111516	69324	LB69326R	PLB6931R02	-
2	PLB6932R	22311LBKC3	LB69323R	H2311032	69324	LB69326R	PLB6932R02	-
2 3/16	PLB6935R*	22313LBKC3	L69353R	H2313035	68444	LB69366R	PLB6935R02	-
2 7/16	PLB6939R*	22315LBKC3	LB68393RA	H2315039	68524	LB68406R	PLB6839R02	-
2 1/2	PLB6940R*	22315LBKC3	LB68403R	SNW115212	68524	LB68406R	PLB6840R02	-
2 11/16	PLB6943R*	22316LBKC3	LB68433RA	H2316043	69444	LB68446R	PLB6843R02	-
2 15/16	PLB6947R*	22317LBKC3	LB69473K	H2317047	68564	LB68486R	PLB6847R02	-
3 3/16	SAF22618303	22318LBKC3	LB68513R	H2318051	68644	LB68526R	-	SAF61830302
3 7/16	SAF22620307	22320LBKC3	LB68553RA	H2320055	68684	LB68566R	-	SAF62030702
3 1/2	SAF22620308	22320LBKC3	LB68563R	SNW120312	68684	LB68566R	-	SAF62030802
3 15/16	SAF22622315	22322LBKC3	LB68633RA	H2322063	69644	LB68646R	-	SAF62231502
4	SAF22622400	22322LBKC3	LB68643R	SNW1224	69644	LB68646R	-	SAF62240002
4 3/16	SAF22624403	22324LBKC3	LB68673R	SNW1244316	69684	LB68686R	-	SAF62440302
4 7/16	SAF22626407	22326LBKC3	LB68713RA	SNW1264716	69724	LB68726R	-	SAF62640702
4 15/16	SAF22628415	22328LBKC3	LB68793R	SNW12841516	69804	LB68806R	-	SAF62841502
5	SAF22628500	22328LBKC3	LB68803R	SNW1285	69804	LB68806R	-	SAF62850002
5 3/16	SAF22630503	22330LBKC3	LB68833R	SNW1305316	69844	LB68846R	-	SAF63050302
5 7/16	SAF22632507	22332LBKC3	LB68873R	SNW1325716	681124	LB68886R	-	SAF63250702
5 15/16	SAF22634515	22334LBKC3	LB68953R	SNW13451516	69964	LB68966R	-	SAF63451502
8 15/16	PLB22648K81516	22348LBKC3	-	SNP14881516	-	-	-	PLB648K8151602
10 7/16	PLB22656K10716	22356LBKC3	-	H235610716	-	-	-	PLB656K1071602

Additional Notes

*2-bolt base listed. For 4-bolt base add suffix F; i.e. PLB6939FR Pillow Block or PLB6939FR02 housing.

Housing part numbers listed above include seals and C-Spacer ring.

PLB7600, PLB7800 Spherical Roller Bearing Unit Replacement Parts

Bearing Dimensions

Shaft Diameter	Pillow Block Part Number	Spherical Roller Bearing Part Number	Labyrinth Seal		C-Spacer Part Number	End Closure Part Number	2-Bolt Cast Iron Adapter Mounted Housing Part Number	4-Bolt Cast Iron Adapter Mounted Housing Part Number
			V1 Part Number	V2 Part Number				
2.9528	PLB7875R*	22215LBC3	L78753R1	LB78753R2	68404	LB68446R	PLB7875R02	-
3.1496	PLB7880R*	22216LBC3	L78803R1	LB68483R	68444	LB68486R	PLB7880R02	-
3.3465	PLB7885R*	22217LBC3	L78853R1	L78853R2	68484	L78856R	PLB7885R02	-
3.5433	PLB7890R*	22218LBC3	LB68663R	L78903R2	68524	LB68526R	PLB7890R02	-
3.9370	PLB78100R*	22220LBC3	LB68723R	L781003R2	68564	L781006R	PLB78100R02	-
4.3307	PLB78110FR	22222LBC3	LB68783R	LB68673R	68644	LB68686R	-	PLB78110FR02
4.7244	PLB78120FR	22224LBC3	LB68853R	LB781203R2	68684	LB68726R	-	PLB78120FR02
5.1181	PLB78130FR	22226LBC3	L781303R1	LB68793R	68724	LB68806R	-	PLB78130FR02
5.5118	PLB78140FR	22228LBC3	L781403R1	LB68853R	68804	LB68846R	-	PLB78140FR02
5.9055	PLB78150FR	22230LBC3	L781503R1	L781503R2	68844	L781506R	-	PLB78150FR02
6.2992	PLB78160FR	22232LBC3	LB681123R	LB781603R2	68924	LB68966R	-	PLB78160FR02
6.6929	PLB78170FR	22234LBC3	L781703R1	LB681033R	68964	LB681046R	-	PLB78170FR02
7.0866	PLB78180FR	22236LBC3	LB681253R	LB681103R	681044	LB681126R	-	PLB78180FR02
7.4803	PLB78190FR	22238LBC3	L781903R1	LB681163R	681124	LB681166R	-	PLB78190FR02
7.8740	PLB78200FR	22240LBC3	L782003R1	L782003R2	681164	L782006R	-	PLB78200FR02
8.6614	PLB78220FR	22244LBC3	L782203R1	L782203R2	681284	L782206R	-	PLB78220FR02
8.6614	PLB22244	22244LBC3	-	-	-	-	-	PLB24402
9.4488	PLB76240FR	23048LBC3	LB661683R	LB762403R2	661444	LB661686	-	PLB76240FR02
9.4488	PLB22248	22248LBC3	-	-	-	-	-	PLB24802
11.0236	PLB76280FR	23056LBC3	LB762803R1	LB762803R2	661684	LB762806	-	PLB76280FR02

Additional Notes

*2-bolt base listed. For 4-bolt base add suffix F; i.e. PLB7875FR Pillow Block or PLB7875FR02 housing.

Housing part numbers listed above include seals and C-Spacer ring.

PLB7900, SAF22300 Spherical Roller Bearing Unit Replacement Parts

Bearing Dimensions

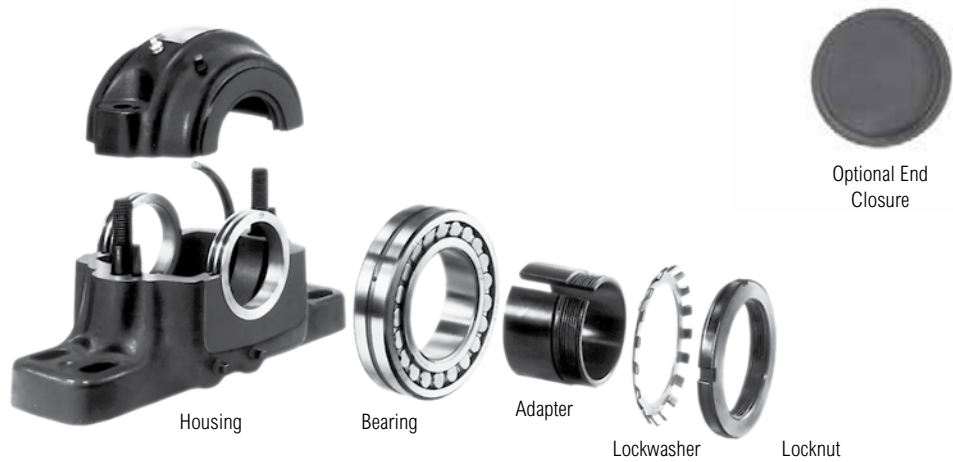
Shaft Diameter	Pillow Block Part Number	Spherical Roller Bearing Part Number	Labyrinth Seal		C-Spacer Part Number	End Closure Part Number	2-Bolt Cast Iron Adapter Mounted Housing Part Number	4-Bolt Cast Iron Adapter Mounted Housing Part Number
			V1	V2				
			Part Number	Part Number				
1.7717	PLB7945R	22309LBC3	LB69343R	LB69273R	69244	LB69286R	PLB7945R02	-
1.9685	PLB7950R	22310LBC3	L79503R1	LB69303R	69284	LB69326R	PLB7950R02	-
2.1654	PLB7955R*	22311LBC3	LB79553R1	LB69333R	69324	LB69366R	PLB7955R02	-
2.5591	PLB7965R*	22313LBC3	LB79653R1	LB68393RA	68444	LB68406R	PLB7965R02	-
2.9528	PLB7975R*	22315LBC3	L78753R1	LB78753R2	68524	LB68446R	PLB7975R02	-
3.1496	PLB7980R*	22316LBC3	L78803R1	LB68483R	69444	LB68486R	PLB7980R02	-
3.3465	PLB7985R*	22317LBC3	L78853R1	L78853R2	68564	L78856R	PLB7985R02	-
3.5433	SAF22318	22318LBC3	LB68663R	L78903R2	69564	LB68526R	-	SAF31802
3.9370	SAF22320	22320LBC3	LB68723R	L781003R2	68684	L781006R	-	SAF32002
4.3307	SAF22322	22322LBC3	LB68783R	LB68673R	69644	LB68686R	-	SAF32202
4.7244	SAF22324	22324LBC3	LB68853R	LB781203R2	69684	LB68726R	-	SAF32402
5.1181	SAF22326	22326LBC3	L781303R1	LB68793R	69724	LB68806R	-	SAF32602
5.5118	SAF22328	22328LBC3	L781403R1	LB68853R	69804	LB68846R	-	SAF32802
5.9055	SAF22330	22330LBC3	L781503R1	L781503R2	69844	L781506R	-	SAF33002
6.2992	SAF22332	22332LBC3	LB681123R	LB781603R2	69884	LB68966R	-	SAF33202
6.6929	SAF22334	22334LBC3	L781703R1	LB681033R	69964	LB681046R	-	SAF33402
9.4488	PLB22348	22348LBC3	-	-	-	-	-	PLB34802
11.0236	PLB22356	22356LBC3	-	-	-	-	-	PLB35602

Additional Notes

*2-bolt base listed. For 4-bolt base add suffix F; i.e. PLB7955FR Pillow Block or PLB7955FR02 housing.

Housing part numbers listed above include seals and C-Spacer ring.

PLB23000K Spherical Roller Bearing Unit Replacement Parts



Bearing Dimensions

Shaft Diameter	Part Number	Bearing Insert	Adapter Assy	Housing Part Number
7 ¹⁵ / ₁₆	PLB23044K71516	23044LBKC3	H3044127	PLB044K7151602
8	PLB23044K8	23044LBKC3	SNW30448	PLB044K802
8 1/2	PLB23048K812	23048LBKC3	SNP3048812	PLB048K81202
8 ¹⁵ / ₁₆	PLB23048K81516	23048LBKC3	SNP30481516	PLB048K8151602
9	PLB23048K9	23048LBKC3	SNP30489	PLB048K902
9 ⁷ / ₁₆	PLB23052K9716	23052LBKC3	SNP30529716	PLB052K971602
9 1/2	PLB23052K912	23052LBKC3	SNP30529716	PLB052K91202
9 ¹⁵ / ₁₆	PLB23056K91516	23056LBKC3	SNP305691516	PLB056K9151602
10	PLB23056K10	23056LBKC3	SNP305610	PLB056K1002
10 ⁷ / ₁₆	PLB23056K10716	23056LBKC3	SNP305610716	PLB056K1071602
10 ¹⁵ / ₁₆	PLB23060K101516	23060LBKC3	SNP3060101516	PLB3060K10151602
11	PLB23060K11	23060LBKC3	SNP3060101516	PLB3060K1102
11 ¹⁵ / ₁₆	PLB23064K111516	23064LBKC3	SNP3064111516	PLB3064K11151602
12	PLB23064K12	23064LBKC3	SNP306412	PLB3064K1202
12 1/2	PLB23068K1212	23068LBKC3	SNP30681212	PLB3068K121202
12 ¹⁵ / ₁₆	PLB23072K121516	23072LBKC3	SNP3072121516	PLB3072K12151602
13	PLB23072K13	23072LBKC3	SNP307213	PLB3072K1302
13 ¹⁵ / ₁₆	PLB23076K131516	23076LBKC3	SNP3076131516	PLB3076K13151602
14	PLB23076K14	23076LBKC3	SNP307614	PLB3076K1402
15	PLB23080K15	23080LBKC3	SNP308015	PLB3080K1502
15 3/4	PLB23084K1534	23084LBKC3	SNP30841534	PLB3084K153402
16 1/2	PLB23088K1612	23088LBKC3	SNP30881612	PLB3088K161202
17	PLB23092K17	23092LBKC3	SNP309217	PLB3092K1702
18	PLB23096K18	23096LBKC3	SNP309618	PLB3096K1802
19 1/2	PLB230530K1912	230530LBKC3	SNP305301912	PLB30530K191202
21	PLB230560K21	230560LBKC3	SNP3056021	PLB30560K2102
22	PLB230600K22	230600LBKC3	SNP3060022	PLB30600K2202
24	PLB230630K24	230630LBKC3	SNP3063024	PLB30630K2402

Additional Notes

Housing part numbers listed above include seals and C-Spacer ring.

PLB23000 Spherical Roller Bearing Unit Replacement Parts



Housing

Bearing

Optional End Closure

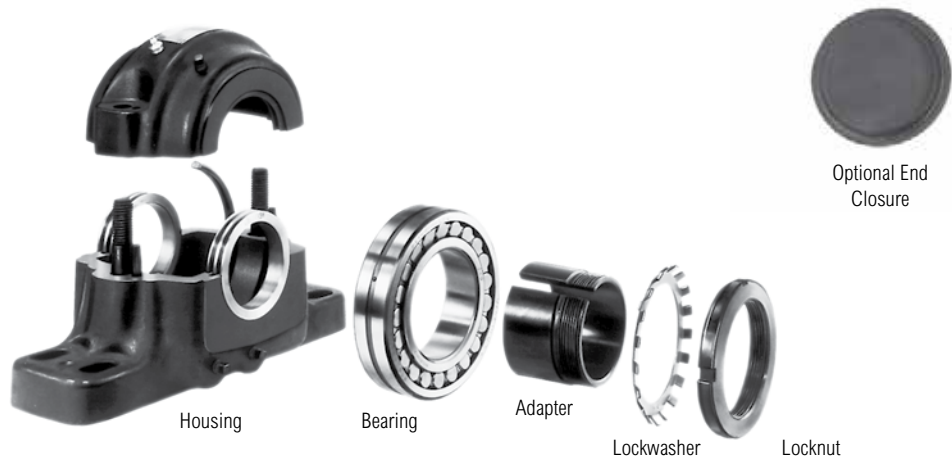
Bearing Dimensions

Shaft Diameter	Part Number	Bearing Insert	Housing Part Number
8.6614	PLB23044	23044LBC3	PLB04402
9.4488	PLB23048	23048LBC3	PLB04802
10.2362	PLB23052	23052LBC3	PLB05202
11.0236	PLB23056	23056LBC3	PLB05602
11.8110	PLB23060	23060LBC3	PLB306002
12.5984	PLB23064	23064LBC3	PLB306402
13.3858	PLB23068	23068LBC3	PLB306802
14.1732	PLB23072	23072LBC3	PLB307202
14.9606	PLB23076	23076LBC3	PLB307602
15.7480	PLB23080	23080LBC3	PLB308002
16.5354	PLB23084	23084LBC3	PLB308402
17.3228	PLB23088	23088LBC3	PLB308802
18.1102	PLB23092	23092LBC3	PLB309202
18.8976	PLB23096	23096LBC3	PLB309602
20.8661	PLB230530	230530LBC3	PLB3053002
22.0472	PLB230560	230560LBC3	PLB3056002

Additional Notes

Housing part numbers listed above include seals and C-Spacer ring.

PLB23100K Spherical Roller Bearing Unit Replacement Parts



Bearing Dimensions

Shaft Diameter	Part Number	Bearing Insert	Adapter Assy	Housing Part Number
8	PLB23144K8	23144LBKC3	SNW30448	PLB3144K802
8 ¹⁵ / ₁₆	PLB23148K81516	23148LBKC3	SNP314881516	PLB3148K8151602
9 ⁷ / ₁₆	PLB23152K9716	23152LBKC3	SNP31529716	PLB3152K971602
10 ⁷ / ₁₆	PLB23156K10716	23156LBKC3	SNP315610716	PLB3156K1071602
10 ¹⁵ / ₁₆	PLB23160K101516	23160LBKC3	SNP3160101516	PLB3160K10151602
11 ¹⁵ / ₁₆	PLB23164K111516	23164LBKC3	SNP3164111516	PLB3164K11151602
12 ⁷ / ₁₆	PLB23168K12716	23168LBKC3	SNP316812716	PLB3168K1271602
13 ⁷ / ₁₆	PLB23172K13716	23172LBKC3	SNP317213716	PLB3172K1371602
13 ¹⁵ / ₁₆	PLB23176K131516	23176LBKC3	SNP3176131516	PLB3176K13151602
15	PLB23180K15	23180LBKC3	SNP318015	PLB3180K1502
15 ³ / ₄	PLB23184K1534	23184LBKC3	SNP31841534	PLB3184K153402
16 ¹ / ₂	PLB23188K1612	23188LBKC3	SNP31881612	PLB3188K161202
17	PLB23192K17	23192LBKC3	SNP319217	PLB3192K1702
18	PLB23196K18	23196LBKC3	SNP319618	PLB3196K1802
19 ¹ / ₂	PLB231530K1912	231530LBKC3	SNP315301912	PLB31530K191202
21	PLB231560K21	231560LBKC3	SNP3156021	PLB31560K2102

Additional Notes

Housing part numbers listed above include seals and C-Spacer ring.

PLB23100 Spherical Roller Bearing Unit Replacement Parts



Housing

Bearing

Optional End Closure

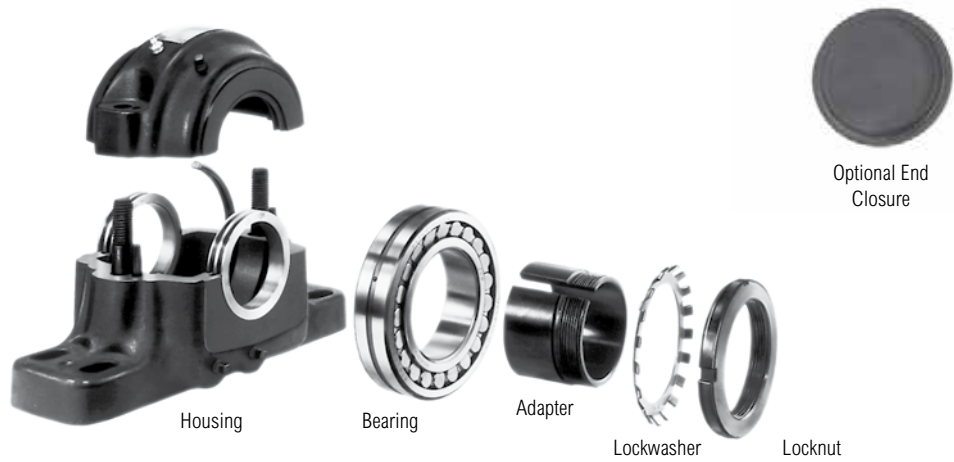
Bearing Dimensions

Shaft Diameter	Part Number	Bearing Insert	Housing Part Number
8.6614	PLB23144	23144LBC3	PLB314402
9.4488	PLB23148	23148LBC3	PLB314802
10.2362	PLB23152	23152LBC3	PLB315202
11.0236	PLB23156	23156LBC3	PLB315602
11.8110	PLB23160	23160LBC3	PLB316002
12.5984	PLB23164	23164LBC3	PLB316402
13.3858	PLB23168	23168LBC3	PLB316802
14.1732	PLB23172	23172LBC3	PLB317202
14.9606	PLB23176	23176LBC3	PLB317602
15.7480	PLB23180	23180LBC3	PLB318002
16.5354	PLB23184	23184LBC3	PLB318402
17.3228	PLB23188	23188LBC3	PLB318802
18.1102	PLB23192	23192LBC3	PLB319202
18.8976	PLB23196	23196LBC3	PLB319602
20.8661	PLB231530	231530LBC3	PLB3153002
22.0472	PLB231560	231560LBC3	PLB3156002

Additional Notes

Housing part numbers listed above include seals and C-Spacer ring.

PLB23200K Spherical Roller Bearing Unit Replacement Parts



Bearing Dimensions

Shaft Diameter	Part Number	Bearing Insert	Adapter Assy	Housing Part Number
8	PLB23244K8	23244LBKC3	SNW1448	PLB3244K802
8 ¹⁵ / ₁₆	PLB23248K81516	23248LBKC3	SNP14881516	PLB3248K8151602
9 ⁷ / ₁₆	PLB23252K9716	23252LBKC3	SNP1529716	PLB3252K971602
10 ⁷ / ₁₆	PLB23256K10716	23256LBKC3	SNP325610716	PLB3256K1071602
10 ¹⁵ / ₁₆	PLB23260K101516	23260LBKC3	SNP3260101516	PLB3260K10151602
11 ¹⁵ / ₁₆	PLB23264K111516	23264LBKC3	SNP3264111516	PLB3264K11151602
12 ⁷ / ₁₆	PLB23268K12716	23268LBKC3	SNP326812716	PLB3268K1271602
13 ⁷ / ₁₆	PLB23272K13716	23272LBKC3	SNP327213716	PLB3272K1371602
13 ¹⁵ / ₁₆	PLB23276K131516	23276LBKC3	SNP3276131516	PLB3276K13151602
15	PLB23280K15	23280LBKC3	SNP328015	PLB3280K1502
15 ³ / ₄	PLB23284K1534	23284LBKC3	SNP32841534	PLB3284K153402
16 ¹ / ₂	PLB23288K1612	23288LBKC3	SNP32881612	PLB3288K161202
17	PLB23292K17	23292LBKC3	SNP329217	PLB3292K1702
18	PLB23296K18	23296LBKC3	SNP329618	PLB3296K1802

Additional Notes

Housing part numbers listed above include seals and C-Spacer ring.

PLB23200 Spherical Roller Bearing Unit Replacement Parts



Bearing Dimensions

Shaft Diameter	Part Number	Bearing Insert	Housing Part Number
8.6614	PLB23244	23244LBC3	PLB324402
9.4488	PLB23248	23248LBC3	PLB324802
10.2362	PLB23252	23252LBC3	PLB325202
11.0236	PLB23256	23256LBC3	PLB325602
11.8110	PLB23260	23260LBC3	PLB326002
12.5984	PLB23264	23264LBC3	PLB326402
13.3858	PLB23268	23268LBC3	PLB326802
14.1732	PLB23272	23272LBC3	PLB327202
14.9606	PLB23276	23276LBC3	PLB327602
15.7480	PLB23280	23280LBC3	PLB328002
16.5354	PLB23284	23284LBC3	PLB328402
17.3228	PLB23288	23288LBC3	PLB328802
18.1102	PLB23292	23292LBC3	PLB329202
18.8976	PLB23296	23296LBC3	PLB329602

Additional Notes

Housing part numbers listed above include seals and C-Spacer ring.

Spherical Roller Bearings: Link-Belt



Contents

	Page
Features and Benefits	256
Nomenclature	257
Engineering	258
Dimensions	
Unmounted Bearings	274
Single-Row	282
Double-Row	283

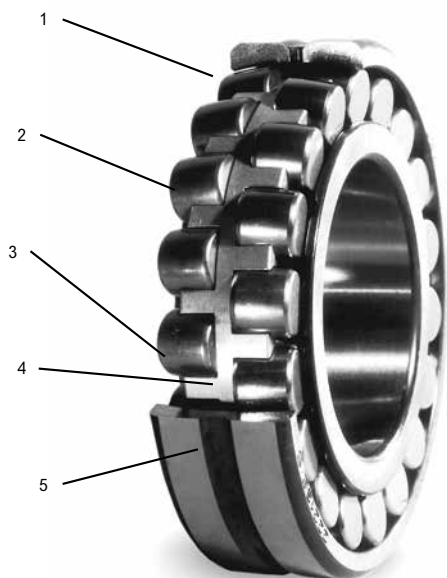
Industries Served

Mining
 Forest Products
 Aggregates
 Steel
 Air Handling
 Construction
 Package Handling
 Wastewater Treatment



Series 22200, 22300, 23000, 23100, 23200 Spherical Roller Bearings

Self-aligning and self-contained spherical roller bearings provide high capacity for heavy-duty and high-precision applications. They are used extensively on earth-moving equipment, vibrating screens, steel mill and paper mill equipment, embossing rolls, printing presses, and torque converters.



1. Positive Roller Guidance is Provided from Rugged Retainer Design

2. Large High-capacity Rollers for Extended Bearing Life

3. Raceway Curvatures

Controlled raceway curvatures afford precise osculation clearance preventing roller edge loading.

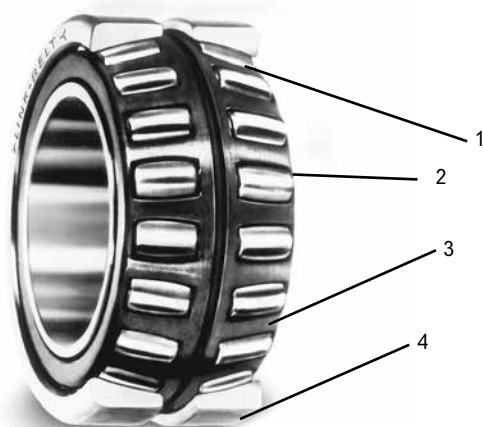
4. Micro-finished Raceways Assure Smooth Operation

5. Maximum Lubrication

Outer ring groove and three symmetrically spaced holes for maximum lubrication access.

Series A20000 Spherical Roller Bearings

Self-aligning separable outer ring bearings of single row adjustable and double row adjustable or non adjustable types for high capacity and minimum space requirements. These compact bearings feature the latest design refinements.



1. Raceway Curvatures.

Controlled raceway curvatures afford precise osculation clearance to avoid edge loading and provide high capacity.

2. Steel Retainer Pockets.

Roller guidance is provided by double contoured coined steel retainer pockets.

3. Large rollers for extended bearing life.

4. Micro-finished raceways assure smooth operation.

Rollers

Rollers' symmetrical roller design permits natural roller positioning and distribution of load in dynamic operation. Curvatures of roller contact surfaces are contoured to control stress distribution under all combinations of radial and thrust loads within design capacities.

Rings

The geometry and sections of the outer and inner rings and rollers result in high capacity and long bearing life. Controlled raceway curvatures on inner and outer rings and rollers afford precise osculation clearances, preventing roller edge loading. Outer ring raceways are spherically finished to provide freedom of alignment under variable conditions.

Retainers

Double contoured deep coined pockets provide accurate roller guidance. Separate retainer for each row of rollers allows rollers to seek ultimate rolling path and operating angle for all radial/thrust load conditions.

22200, 22300, 23000, 23100, 23200, 23900 Nomenclature

Symbol	Description	2	22	16	LB	K	W33	C0
2	Used to distinguish from other series	_____	_____	_____	_____	_____	_____	_____
22	Bearing dimension series (22, 23, 30, 31, 32, 39)	_____	_____	_____	_____	_____	_____	_____
16	One-fifth of bore diameter (mm)	_____	_____	_____	_____	_____	_____	_____
LB	Designation for Link-Belt spherical roller bearing	_____	_____	_____	_____	_____	_____	_____
None	Cylindrical bore	_____	_____	_____	_____	_____	_____	_____
K	Tapered bore	_____	_____	_____	_____	_____	_____	_____
W33	Lubrication holes and groove in outer ring (standard)	_____	_____	_____	_____	_____	_____	_____
C2	Internal clearance less than C0	_____	_____	_____	_____	_____	_____	_____
C0	Basic internal clearance	_____	_____	_____	_____	_____	_____	_____
C3	Internal clearance greater than C0 (standard)	_____	_____	_____	_____	_____	_____	_____
C4	Internal clearance greater than C3	_____	_____	_____	_____	_____	_____	_____

A20000 Nomenclature

Symbol	Description	A	22	196	M	C0	C40
A	Spherical roller bearing, separable outer ring(s)	_____	_____	_____	_____	_____	_____
22	Basic bearing series	_____	_____	_____	_____	_____	_____
23	Larger O.D. or greater load rating than series 22	_____	_____	_____	_____	_____	_____
24	Larger O.D. or greater load rating than series 23	_____	_____	_____	_____	_____	_____
196	Bore size in hundredths of an inch	_____	_____	_____	_____	_____	_____
None	Double row roller bearing; separable outer rings	_____	_____	_____	_____	_____	_____
M	Double row bearing; separable outer rings with spacer for preadjusted clearance	_____	_____	_____	_____	_____	_____
S	Single row roller bearing; adjustable	_____	_____	_____	_____	_____	_____
C2	Internal clearance less than C0	_____	_____	_____	_____	_____	_____
C0	Standard internal clearance	_____	_____	_____	_____	_____	_____
C3	Internal clearance greater than C0	_____	_____	_____	_____	_____	_____
W22	Reduced O.D. tolerance in center of tolerance range	_____	_____	_____	_____	_____	_____
C40	Reduced O.D. tolerance in high half of tolerance range	_____	_____	_____	_____	_____	_____
C50	Reduced O.D. tolerance in low half of tolerance range	_____	_____	_____	_____	_____	_____

Spherical Roller Bearing Series 22200, 22300, 23000, 23100, 23200 and 23900 Selection Guide

To select a pillow block, determine the applied radial load, the applied thrust load, the desired Rating Life, the required minimum shaft size, and applicable operating conditions. The procedure shown here will aid in selecting a pillow block to meet an L_{10} design life. The formulas for calculating life expectancy should be used to determine the Rating Life L_{10} for the pillow block selected. Spherical roller bearing pillow blocks are available in Series 22200, 22300, 23000, 23100, 23200, and 23900. Because a number of series are available, several different pillow blocks that will fulfill and L_{10} life requirement can often be chosen.

Some of the factors to consider when choosing between series are: cost, speed limit, minimum shaft diameter, thrust load, space limitations, and type of shaft mounting.

The selection procedures and rating formulas shown here are in agreement with The American Bearing Manufacturers Association Standards and ANSI/ ABMA Standards STD 11-1990. Ratings are based on fatigue life.

Steps for Selection

Step 1

Determine an appropriate L_{10} design life.

Type of service	Operating time, hours per year	Design life, years	L_{10} design life, hours
Heavy seasonal usage	1,400 to 1,600	4-6	8,000
Industrial—8 hour shift	2,000	10	20,000
Industrial—16 hour shift	4,000	10	40,000
Industrial—continuous	8,700	10	80,000 to 100,000
Industrial—High reliability	—	—	120,000 to 300,000

Step 2

Determine a required $\left(\frac{C}{P}\right)$ from Table 1.

Step 3

Calculate the required C and select a roller bearing pillow block.

a For radial load only: $P = F_r$

Required $C = \left(\frac{C}{P}\right)P$ using $\left(\frac{C}{P}\right)$ from Step 2

Select a roller bearing pillow block from Tables 2 - 7 having a basic load rating C equal to or greater than the required C.

The Rating Life L_{10} or fatigue life at 90% reliability is the usual basis for bearing selection.

To assure a satisfactory bearing application, fitting practice, mounting, lubrication, sealing, static rating, housing strength, operating conditions and maintenance must be considered.

b For combined radial and thrust loads:

Select a roller bearing pillow block of the desired shaft size from Tables 2 - 7
Calculate the ratio of thrust load F_a to the radial load F_r .

$$\frac{F_a}{F_r}$$

Calculate the equivalent radial load P

$$P = X F_r + Y F_a$$

If $\frac{F_a}{F_r}$ is equal to or less than e, then $P = X_1 F_r + Y_1 F_a$

If $\frac{F_a}{F_r}$ is greater than e, then $P = X_2 F_r + Y_2 F_a$

For values of e, X_1 , Y_1 , X_2 , and Y_2 , see Tables 2 - 7

Required $C = \left(\frac{C}{P}\right)P$ using $\left(\frac{C}{P}\right)$ from Step 2

Consult the bearing rating Tables 2 - 7, to see if the selected bearing meets or exceeds the required C. The life expectancy of other sizes and series of bearings can be calculated similarly.

Selection

Symbols for formulas:

C = basic load rating, pounds (or newtons)	L ₁₀ = rating life, hours
C ₀ = static load rating, pounds (or newtons)	n = speed, revolutions per minute
e = a reference value	P = equivalent radial load, pounds (or newtons)
F _a = thrust load, pounds (or newtons)	X = radial factor
F _r = radial load, pounds (or newtons)	Y = thrust factor

Table 1 • Relation of L₁₀ life and speed to $\left(\frac{C}{P}\right)$

Bearing Life Hours L ₁₀	Speed, n									
	50	100	200	300	400	500	600	700	800	
3000	1.93	2.38	2.93	3.31	3.61	3.86	4.07	4.27	4.44	
4000	2.11	2.59	3.19	3.61	3.93	4.20	4.44	4.65	4.84	
5000	2.25	2.77	3.42	3.86	4.20	4.50	4.75	4.97	5.18	
6000	2.38	2.93	3.61	4.07	4.44	4.75	5.02	5.25	5.47	
8000	2.59	3.19	3.93	4.44	4.84	5.18	5.47	5.73	5.96	
10000	2.77	3.42	4.20	4.75	5.18	5.54	5.85	6.12	6.37	
12000	2.93	3.61	4.44	5.02	5.47	5.85	6.18	6.47	6.73	
14000	3.07	3.78	4.65	5.25	5.73	6.12	6.47	6.77	7.05	
16000	3.19	3.93	4.84	5.47	5.96	6.37	6.73	7.05	7.34	
18000	3.31	4.07	5.02	5.66	6.18	6.60	6.97	7.30	7.60	
20000	3.42	4.20	5.18	5.85	6.37	6.81	7.20	7.54	7.85	
25000	3.65	4.50	5.54	6.25	6.81	7.29	7.70	8.06	8.39	
30000	3.86	4.75	5.85	6.60	7.20	7.70	8.13	8.51	8.86	
35000	4.04	4.97	6.12	6.92	7.54	8.06	8.51	8.92	9.28	
40000	4.20	5.18	6.37	7.20	7.85	8.39	8.86	9.28	9.66	
45000	4.36	5.36	6.60	7.46	8.13	8.69	9.18	9.61	10.00	
50000	4.50	5.54	6.81	7.70	8.39	8.97	9.48	9.92	10.30	
60000	4.75	5.85	7.20	8.13	8.86	9.48	10.00	10.50	10.90	
70000	4.97	6.12	7.54	8.51	9.28	9.92	10.50	11.00	11.40	
80000	5.18	6.37	7.85	8.86	9.66	10.30	10.90	11.40	11.90	
90000	5.36	6.60	8.13	9.18	10.00	10.70	11.30	11.80	12.30	
100000	5.54	6.81	8.39	9.48	10.30	11.00	11.70	12.20	12.70	
150000	6.25	7.70	9.48	10.70	11.70	12.50	13.20	13.80	14.40	
200000	6.81	8.39	10.30	11.70	12.70	13.60	14.40	15.00	15.70	

	Speed, n									
	900	1000	1200	1500	1800	2400	3000	3600	6000	
3000	4.60	4.75	5.02	5.36	5.66	6.18	6.60	6.97	8.13	
4000	5.02	5.18	5.47	5.85	6.18	6.73	7.20	7.60	8.86	
5000	5.36	5.54	5.85	6.25	6.60	7.20	7.70	8.13	9.48	
6000	5.66	5.85	6.18	6.60	6.97	7.60	8.13	8.59	10.00	
8000	6.18	6.37	6.73	7.20	7.60	8.29	8.86	9.36	10.90	
10000	6.60	6.81	7.20	7.70	8.13	8.86	9.48	10.00	11.70	
12000	6.97	7.20	7.60	8.13	8.59	9.36	10.00	10.60	12.30	
14000	7.30	7.54	7.96	8.51	8.99	9.80	10.50	11.10	12.90	
16000	7.60	7.85	8.29	8.86	9.36	10.20	10.90	11.50	13.40	
18000	7.88	8.13	8.59	9.18	9.70	10.60	11.30	11.90	13.90	
20000	8.13	8.39	8.86	9.48	10.00	10.90	11.70	12.30	14.40	
25000	8.69	8.97	9.48	10.10	10.70	11.70	12.50	13.20	15.40	
30000	9.18	9.48	10.00	10.70	11.30	12.30	13.20	13.90	16.20	
35000	9.61	9.92	10.50	11.20	11.80	12.90	13.80	14.60	17.00	
40000	10.00	10.30	10.90	11.70	12.30	13.40	14.40	15.20	17.70	
45000	10.40	10.70	11.30	12.10	12.80	13.90	14.90	15.70	18.30	
50000	10.70	11.00	11.70	12.50	13.20	14.40	15.40	16.20	18.90	
60000	11.30	11.70	12.30	13.20	13.90	15.20	16.20	17.10	20.00	
70000	11.80	12.20	12.90	13.80	14.60	15.90	17.00	17.90	20.90	
80000	12.30	12.70	13.40	14.40	15.20	16.50	17.70	18.70	21.80	
90000	12.80	13.20	13.90	14.90	15.70	17.10	18.30	19.40	22.60	
100000	13.20	13.60	14.40	15.40	16.20	17.70	18.90	20.00	23.30	
150000	14.90	15.40	16.20	17.30	18.30	20.00	21.40	22.60	26.30	
200000	16.20	16.70	17.70	18.90	20.00	21.80	23.30	24.60	28.70	

Basic Formula

$$\left(\frac{C}{P}\right) = \left(\frac{L_{10} \times n \times 60}{1,000,000}\right)^{3/10}$$

$$L_{10} = \frac{\left(\frac{C}{P}\right)^{10/3} \times 1,000,000}{n \times 60}$$

Life Expectancy

To calculate the Rating Life L₁₀ of any selected or trial bearing:

Step 1

Determine the equivalent radial load P.

a For radial load only:

$$P = F_r$$

b For combined radial and thrust load:

$$P = X F_r + Y F_a$$

if $\frac{F_a}{F_r}$ is equal to or less than e, then

$$P = X_1 F_r + Y_1 F_a$$

if $\frac{F_a}{F_r}$ is greater than e, then

$$P = X_2 F_r + Y_2 F_a$$

For values of e, X₁, Y₁, X₂, and Y₂, consult the appropriate bearing rating Table 2 Table 4.

Step 2

Calculate the ratio of the basic load rating C to the equivalent radial load.

$$\left(\frac{C}{P}\right)$$

Step 3

Approximate the bearing life from Table 1.

Live Adjustment

The Rating Life, L₁₀, may be modified for some applications in accordance with the formula

$$L_n = a_1 a_2 a_3 L_{10}$$

where L_n = Adjusted life for (100-n) % reliability,

a₁ = Life adjustment factor for reliability

a₂ = Life adjustment factor

for material and processing

a₃ = Life adjustment factor for operating conditions.

For most normal applications, all factors will be taken as 1, and the Rating Life used as the selection basis or life estimate. In addition, as long as standard catalog bearings are used, a₂ will be normally set equal to one.

The factor a₃ covers such things as lubrication, misalignment, and temperature. Some conditions that could yield a₃ significantly different than unity include speeds less than 20000 DN or greater than 200000 DN, temperatures below -40°F (-40°C) or above 275°F (135°C). For other possible conditions, as well as additional information on life adjustment factors, consult Rexnord Bearing Division.

Table 2 • Series 22200LB, 22200LBK Load Ratings and Speed Limits

Bearing Number		Co Static Load Rating		C Basic Load Rating		Speed Limit, RPM		e	$\frac{F_a}{F_r} \leq e$		$\frac{F_a}{F_r} > e$	
Cylindrical Bore	Tapered bore	newtons	pounds	newtons	pounds	Grease	Oil		X1	Y1	X2	Y2
22209LB	22209LBK	105000	23600	92500	20800	5300	6200	0.26	1.00	2.6	0.67	3.9
22210LB	22210LBK	113000	25500	97900	22000	5000	5500	0.26	1.00	2.8	0.67	4.2
22211LB	22211LBK	145000	32500	120000	27000	4500	5000	0.23	1.00	2.9	0.67	4.4
22212LB	22212LBK	180000	40500	151000	34000	4000	4500	0.24	1.00	2.8	0.67	4.2
22213LB	22213LBK	207000	46500	169000	38000	3800	4300	0.24	1.00	2.8	0.67	4.2
22214LB	22214LBK	222000	50000	178000	40000	3600	4000	0.23	1.00	2.9	0.67	4.4
22215LB	22215LBK	236000	53000	185000	41500	3400	3700	0.22	1.00	3.1	0.67	4.6
22216LB	22216LBK	260000	58500	207000	46500	3200	3500	0.22	1.00	3.1	0.67	4.7
22217LB	22217LBK	327000	73500	260000	58500	3000	3250	0.22	1.00	3.0	0.67	4.5
22218LB	22218LBK	363000	81500	285000	64000	2600	3000	0.23	1.00	2.9	0.67	4.3
22219LB	22219LBK	400000	90000	316000	71000	2400	2900	0.24	1.00	2.9	0.67	4.3
22220LB	22220LBK	463000	104000	356000	80000	2200	2800	0.24	1.00	2.8	0.67	4.2
22222LB	22222LBK	587000	132000	454000	102000	2000	2500	0.25	1.00	2.7	0.67	4.0
22224LB	22224LBK	725000	163000	534000	120000	1900	2300	0.25	1.00	2.7	0.67	4.0
22226LB	22226LBK	872000	196000	636000	143000	1800	2100	0.26	1.00	2.6	0.67	3.9
22228LB	22228LBK	1010000	228000	738000	166000	1700	1950	0.25	1.00	2.7	0.67	4.0
22230LB	22230LBK	1200000	270000	845000	190000	1600	1850	0.25	1.00	2.7	0.67	4.0
22232LB	22232LBK	1380000	310000	961000	216000	1500	1700	0.26	1.00	2.6	0.67	3.9
22234LB	22234LBK	1530000	345000	1110000	250000	1300	1600	0.26	1.00	2.6	0.67	3.9
22236LB	22236LBK	1620000	365000	1130000	255000	1300	1500	0.25	1.00	2.7	0.67	4.0
22238LB	22238LBK	1850000	415000	1200000	270000	1200	1400	0.28	1.00	2.4	0.67	3.6
22240LB	22240LBK	2000000	450000	1330000	300000	1100	1300	0.29	1.00	2.3	0.67	3.5
22244LB	22244LBK	2450000	550000	1620000	365000	1000	1200	0.29	1.00	2.3	0.67	3.5
22248LB	22248LBK	2890000	650000	1870000	420500	750	950	0.27	1.00	2.5	0.67	3.7

If the load P is greater than .25C, consult Rexnord Bearing Division.

Speed limits are based on the following:

1. Negligible seal torque (e.g., non-contact seals).
2. Proper operating internal clearance.
3. Adequate lubrication and maintenance (special lubricants and/or more frequent relubrication may be required).
4. Normal room temperature environment and no extraneous heat sources, such that bearing operating temperature does not exceed 100°C (212°F).
5. Equivalent radial load not greater than 7% of C.
6. Axial load, if any, not greater than 20% of radial load.

Table 3 • Series 22300LB,22300LBK Load Ratings and Speed Limits

Bearing Number		Co Static Load Rating		C Basic Load Rating		Speed Limit RPM		$\frac{F_a}{F_r} \leq e$			$\frac{F_a}{F_r} > e$	
Cylindrical Bore	Tapered Bore	newtons	pounds	newtons	pounds	Grease	Oil	e	X1	Y1	X2	Y2
22308LB	22308LBK	145000	32500	129000	29000	4500	5600	0.36	1.00	1.9	0.67	2.8
22309LB	22309LBK	178000	40000	158000	35500	3800	4800	0.36	1.00	1.9	0.67	2.8
22310LB	22310LBK	214000	48000	189000	42500	3600	4300	0.36	1.00	1.9	0.67	2.8
22311LB	22311LBK	254000	57000	222000	50000	3200	4000	0.36	1.00	1.9	0.67	2.8
22312LB	22312LBK	302000	68000	260000	58500	3000	3800	0.35	1.00	1.9	0.67	2.8
22313LB	22313LBK	356000	80000	291000	65500	2600	3400	0.34	1.00	2.0	0.67	3.0
22314LB	22314LBK	378000	85000	320000	72000	2400	3200	0.34	1.00	2.0	0.67	3.0
22315LB	22315LBK	436000	98000	369000	83000	2200	3000	0.34	1.00	2.0	0.67	3.0
22316LB	22316LBK	498000	112000	414000	93000	2000	2800	0.34	1.00	2.0	0.67	3.0
22317LB	22317LBK	543000	122000	454000	102000	1900	2600	0.33	1.00	2.0	0.67	3.0
22318LB	22318LBK	623000	140000	507000	114000	1800	2400	0.33	1.00	2.0	0.67	3.0
22319LB	22319LBK	681000	153000	556000	125000	1800	2400	0.33	1.00	2.0	0.67	3.0
22320LB	22320LBK	814000	183000	649000	146000	1700	2200	0.34	1.00	2.0	0.67	3.0
22322LB	22322LBK	1050000	236000	801000	180000	1600	2000	0.33	1.00	2.1	0.67	3.1
22324LB	22324LBK	1160000	260000	907000	204000	1400	1800	0.33	1.00	2.1	0.67	3.1
22326LB	22326LBK	1360000	305000	1050000	236000	1300	1700	0.33	1.00	2.1	0.67	3.1
22328LB	22328LBK	1600000	360000	1220000	275000	1100	1500	0.34	1.00	2.0	0.67	3.0
22330LB	22330LBK	1800000	405000	1380000	310000	1000	1400	0.33	1.00	2.0	0.67	3.0
22332LB	22332LBK	1890000	425000	1450000	325000	950	1300	0.37	1.00	1.8	0.67	2.7
22334LB	22334LBK	2110000	475000	1600000	360000	950	1300	0.37	1.00	1.8	0.67	2.7
22336LB	22336LBK	2360000	530000	1730000	390000	900	1200	0.37	1.00	1.8	0.67	2.7
22338LB	22338LBK	2540000	570000	1850000	415000	850	1100	0.37	1.00	1.8	0.67	2.7
22340LB	22340LBK	2800000	630000	2070000	465000	850	1100	0.36	1.00	1.9	0.67	2.8
22344LB	22344LBK	3340000	750000	2360000	530000	700	900	0.35	1.00	2.0	0.67	2.9
22348LB	22348LBK	3800000	854500	2600000	584500	670	850	0.32	1.00	2.1	0.67	3.2
22356LB	22356LBK	5150000	1157800	3500000	787000	560	710	0.31	1.00	2.1	0.67	3.2

If the load P is greater than .25C, consult Rexnord Bearing Division.

Speed limits are based on the following:

1. Negligible seal torque (e.g., non-contact seals).
2. Proper operating internal clearance.
3. Adequate lubrication and maintenance (special lubricants and/or more frequent relubrication may be required).
4. Normal room temperature environment and no extraneous heat sources, such that bearing operating temperature does not exceed 100°C (212°F).
5. Equivalent radial load not greater than 7% of C.
6. Axial load, if any, not greater than 20% of radial load.

Table 4 – Series 23000LB, 23000LBK Load Ratings and Speed Limits

Bearing Number		Co Static Load Rating		C Basic Dynamic Load Rating		Speed Limit, RPM		Fa/Fr ≤ e			Fa/Fr > e	
Cylindrical Bore	Tapered Bore	newtons	pounds	newtons	pounds	Grease	Oil	e	X1	Y1	X2	Y2
23044LB	23044LBK	1980000	445100	1090000	245000	950	1200	0.24	1.00	2.8	0.67	4.1
23048LB	23048LBK	2180000	490000	1160000	260000	950	1100	0.25	1.00	2.7	0.67	4.1
23052LB	23052LBK	2580000	580000	1430000	321500	800	950	0.25	1.00	2.7	0.67	4.1
23056LB	23056LBK	2980000	670000	1530000	345000	800	950	0.25	1.00	2.7	0.67	4.1
23060LB	23060LBK	3700000	832000	1920000	431600	670	850	0.24	1.00	2.8	0.67	4.2
23064LB	23064LBK	3850000	865500	1960000	440600	630	800	0.24	1.00	2.8	0.67	4.2
23068LB	23068LBK	4400000	989200	2280000	512600	560	710	0.24	1.00	2.8	0.67	4.2
23072LB	23072LBK	4700000	1056600	2390000	537500	530	670	0.24	1.00	2.8	0.67	4.2
23076LB	23076LBK	5100000	1146500	2500000	562000	530	630	0.22	1.00	3.0	0.67	4.5
23080LB	23080LBK	5900000	1326500	2970000	668000	480	600	0.23	1.00	3.0	0.67	4.4
23084LB	23084LBK	5850000	1315200	2910000	654200	450	560	0.23	1.00	2.9	0.67	4.3
23088LB	23088LBK	6350000	1427500	3150000	708200	430	530	0.23	1.00	2.9	0.67	4.3
23092LB	23092LBK	7100000	1596200	3450000	775600	400	500	0.22	1.00	3.1	0.67	4.6
23096LB	23096LBK	7950000	1787200	3800000	854300	400	480	0.22	1.00	3.1	0.67	4.6
230530LB	230530LBK	9200000	2068200	4400000	989200	340	430	0.22	1.00	3.1	0.67	4.6
230560LB	230560LBK	10700000	2405500	5000000	1124000	320	400	0.22	1.00	3.0	0.67	4.5
230600LB	230600LBK	12200000	2743000	5450000	1225200	300	360	0.21	1.00	3.3	0.67	4.8
230630LB	230630LBK	12700000	2855000	5900000	1326400	280	340	0.22	1.00	3.1	0.67	4.7

If the load P is greater than .25C, consult Rexnord Bearing Division.

Speed limits are based on the following:

1. Negligible seal torque (e.g., non-contact seals).
2. Proper operating internal clearance.
3. Adequate lubrication and maintenance (special lubricants and/or more frequent relubrication may be required).
4. Normal room temperature environment and no extraneous heat sources, such that bearing operating temperature does not exceed 100°C (212°F).
5. Equivalent radial load not greater than 7% of C.
6. Axial load, if any, not greater than 20% of radial load.

Table 5 – Series 23100LB, 23100LBK Load Ratings and Speed Limits

Bearing Number		Co Static Load Rating		C Basic Dynamic Load Rating		Speed Limit, RPM		Fa/Fr ≤ e			Fa/Fr > e	
Cylindrical Bore	Tapered Bore	newtons	pounds	newtons	pounds	Grease	Oil	e	X1	Y1	X2	Y2
23144LB	23144LBK	2710000	609200	1570000	353000	710	950	0.30	1.00	2.2	0.67	3.3
23148LB	23148LBK	3100000	697000	1790000	402500	670	850	0.30	1.00	2.2	0.67	3.3
23152LB	23152LBK	3750000	843000	2160000	485500	600	800	0.32	1.00	2.1	0.67	3.2
23156LB	23156LBK	4000000	899300	2230000	501500	560	750	0.30	1.00	2.2	0.67	3.3
23160LB	23160LBK	4800000	1079000	2670000	600500	500	670	0.31	1.00	2.2	0.67	3.3
23164LB	23164LBK	5500000	1236500	3050000	685700	480	600	0.31	1.00	2.1	0.67	3.2
23168LB	23168LBK	6600000	1483800	3600000	809500	430	560	0.31	1.00	2.1	0.67	3.2
23172LB	23172LBK	7100000	1596200	3800000	854500	400	530	0.31	1.00	2.2	0.67	3.2
23176LB	23176LBK	7600000	1708500	4000000	899200	400	500	0.30	1.00	2.2	0.67	3.3
23180LB	23180LBK	7900000	1776000	4150000	933000	380	480	0.29	1.00	2.3	0.67	3.4
23184LB	23184LBK	9400000	2113200	5000000	1124000	340	450	0.31	1.00	2.2	0.67	3.3
23188LB	23188LBK	10300000	2315500	5300000	1191500	320	430	0.30	1.00	2.2	0.67	3.3
23192LB	23192LBK	10900000	2450500	5700000	1281400	300	400	0.31	1.00	2.2	0.67	3.3
23196LB	23196LBK	11700000	2630500	6050000	1360100	300	380	0.31	1.00	2.2	0.67	3.3
231530LB	231530LBK	14100000	3169800	7150000	1607400	260	340	0.30	1.00	2.2	0.67	3.3
231560LB	231560LBK	15500000	3484500	7850000	1764800	240	320	0.30	1.00	2.3	0.67	3.4
231600LB	231600LBK	17500000	3934000	8750000	1967000	220	280	0.30	1.00	2.3	0.67	3.4
231630LB	231630LBK	19400000	4361100	9600000	2158100	200	260	0.30	1.00	2.3	0.67	3.4

If the load P is greater than .25C, consult Rexnord Bearing Division.

Speed limits are based on the following:

1. Negligible seal torque (e.g., non-contact seals).
2. Proper operating internal clearance.
3. Adequate lubrication and maintenance (special lubricants and/or more frequent relubrication may be required).
4. Normal room temperature environment and no extraneous heat sources, such that bearing operating temperature does not exceed 100°C (212°F).
5. Equivalent radial load not greater than 7% of C.
6. Axial load, if any, not greater than 20% of radial load.

Table 6 – Series 23200LB, 23200LBK Load Ratings and Speed Limits

Bearing Number		Co Static Load Rating		C Basic Dynamic Load Rating		Speed Limit, RPM		Fa/Fr ≤ e			Fa/Fr > e	
Cylindrical Bore	Tapered Bore	newtons	pounds	newtons	pounds	Grease	Oil	e	X1	Y1	X2	Y2
23244LB	23244LBK	3400000	764500	2020000	454000	670	900	0.35	1.00	1.9	0.67	2.9
23248LB	23248LBK	4050000	910500	2440000	548500	630	800	0.37	1.00	1.8	0.67	2.7
23252LB	23252LBK	4550000	1022900	2740000	616000	560	750	0.37	1.00	1.8	0.67	2.7
23256LB	23256LBK	4900000	1101600	2880000	647500	530	670	0.35	1.00	1.9	0.67	2.9
23260LB	23260LBK	5900000	1326400	3400000	764500	480	630	0.35	1.00	1.9	0.67	2.9
23264LB	23264LBK	6900000	1551200	3900000	877000	450	600	0.36	1.00	1.9	0.67	2.8
23268LB	23268LBK	7800000	1753500	4400000	989200	400	530	0.36	1.00	1.9	0.67	2.8
23272LB	23272LBK	8550000	1922100	4800000	1079000	380	500	0.36	1.00	1.9	0.67	2.8
23276LB	23276LBK	9200000	2068500	5150000	1157800	360	480	0.35	1.00	1.9	0.67	2.9
23280LB	23280LBK	10400000	2338000	5800000	1303900	340	450	0.36	1.00	1.9	0.67	2.8
23284LB	23284LBK	11700000	2630500	6450000	1450000	320	430	0.35	1.00	1.9	0.67	2.9
23288LB	23288LBK	12800000	2877500	6900000	1551200	300	400	0.35	1.00	1.9	0.67	2.9
23292LB	23292LBK	13700000	3080000	7350000	1652400	280	380	0.36	1.00	1.9	0.67	2.8
23296LB	23296LBK	14400000	3237500	7850000	1764800	260	360	0.36	1.00	1.9	0.67	2.8

If the load P is greater than .25C, consult Rexnord Bearing Division.

Speed limits are based on the following:

1. Negligible seal torque (e.g., non-contact seals).
2. Proper operating internal clearance.
3. Adequate lubrication and maintenance (special lubricants and/or more frequent relubrication may be required).
4. Normal room temperature environment and no extraneous heat sources, such that bearing operating temperature does not exceed 100°C (212°F).
5. Equivalent radial load not greater than 7% of C.
6. Axial load, if any, not greater than 20% of radial load.

Table 7 – Series 23900LB, 23900LBK Load Ratings and Speed Limits

Bearing Number		Co Static Load Rating		C Basic Dynamic Load Rating		Speed Limit, RPM		Fa/Fr ≤ e			Fa/Fr > e	
Cylindrical Bore	Tapered Bore	newtons	pounds	newtons	pounds	Grease	Oil	e	X1	Y1	X2	Y2
23944LB	23944LBK	1240000	279000	625000	140500	1000	1300	0.18	1.00	3.8	0.67	5.7
23948LB	23948LBK	1300000	292500	635000	143000	950	1200	0.17	1.00	4.0	0.67	6.0

If the load P is greater than .25C, consult Rexnord Bearing Division.

Speed limits are based on the following:

1. Negligible seal torque (e.g., non-contact seals).
2. Proper operating internal clearance.
3. Adequate lubrication and maintenance (special lubricants and/or more frequent relubrication may be required).
4. Normal room temperature environment and no extraneous heat sources, such that bearing operating temperature does not exceed 100°C (212°F).
5. Equivalent radial load not greater than 7% of C.
6. Axial load, if any, not greater than 20% of radial load.

Cylindrical Bore Bearings - Radial Clearances

Series 22200, 22300, 23000, 23100, 23200		Radial Internal Clearance, Inches							
Basic Size	Bore (mm)	C2		C0		C3 (basic)		C4	
		Min	Max	Min	Max	Min	Max	Min	Max
08	40	0.0006	0.0012	0.0012	0.0018	0.0018	0.0024	0.0024	0.0032
09	45	0.0008	0.0014	0.0014	0.0022	0.0022	0.0030	0.0030	0.0039
10	50								
11	55	0.0010	0.0017	0.0017	0.0026	0.0026	0.0036	0.0036	0.0047
12	60								
13	65								
14	70	0.0012	0.0020	0.0020	0.0032	0.0032	0.0044	0.0044	0.0057
15	75								
16	80								
17	85								
18	90	0.0014	0.0025	0.0025	0.0039	0.0039	0.0053	0.0053	0.0071
19	95								
20	100								
22	110								
24	120	0.0017	0.0031	0.0031	0.0048	0.0048	0.0064	0.0064	0.0083
26	130								
28	140	0.0020	0.0038	0.0038	0.0057	0.0057	0.0075	0.0075	0.0095
30	150								
32	160	0.0024	0.0043	0.0043	0.0065	0.0065	0.0087	0.0087	0.0110
34	170								
36	180	0.0026	0.0047	0.0047	0.0071	0.0071	0.0095	0.0095	0.0122
38	190								
40	200	0.0028	0.0051	0.0051	0.0079	0.0079	0.0103	0.0103	0.0133
44	220								
48	240	0.0032	0.0055	0.0055	0.0087	0.0087	0.0114	0.0114	0.0149
52	260								
56	280	0.0036	0.0059	0.0059	0.0095	0.0095	0.0126	0.0126	0.0165
60	300								
64	320	0.0039	0.0067	0.0067	0.0103	0.0103	0.0138	0.0138	0.0180
68	340								
72	360	0.0044	0.0075	0.0075	0.0110	0.0110	0.0145	0.0145	0.0197
76	380								
80	400	0.0047	0.0079	0.0079	0.0122	0.0122	0.0161	0.0161	0.0217
84	420								
88	440	0.0051	0.0087	0.0087	0.0134	0.0134	0.0177	0.0177	0.0236
92	460								
96	480	0.0055	0.0094	0.0094	0.0146	0.0146	0.0197	0.0197	0.0260
	530								
	560	0.0055	0.0102	0.0102	0.0161	0.0161	0.0217	0.0217	0.0283
	600								
	630	0.0059	0.0110	0.0110	0.0173	0.0173	0.0236	0.0236	0.0307
		0.0067	0.0122	0.0122	0.0189	0.0189	0.0256	0.0256	0.0335

C2 = Internal clearance less than C0

C0 = Internal clearance

C3 = Internal clearance greater than C0

C4 = Internal clearance greater than C3

Tapered Bore Bearings - Radial Clearances

Series 22200, 22300, 23000, 23100, 23200		Radial Internal Clearance, Inches							
Basic Size	Bore (mm)	C2		C0		C3 (basic)		C4	
		Min	Max	Min	Max	Min	Max	Min	Max
08	40	0.0008	0.0014	0.0014	0.0020	0.0020	0.0026	0.0026	0.0033
09	45	0.0012	0.0018	0.0018	0.0024	0.0024	0.0031	0.0031	0.0039
10	50								
11	55	0.0014	0.0022	0.0022	0.0030	0.0030	0.0037	0.0037	0.0047
12	60								
13	65								
14	70	0.0018	0.0028	0.0028	0.0037	0.0037	0.0047	0.0047	0.0059
15	75								
16	80								
17	85	0.0020	0.0030	0.0030	0.0043	0.0043	0.0055	0.0055	0.0071
18	90								
19	95								
20	100	0.0025	0.0039	0.0039	0.0053	0.0053	0.0067	0.0067	0.0087
22	110								
24	120	0.0030	0.0047	0.0047	0.0063	0.0063	0.0079	0.0079	0.0102
26	130								
28	140	0.0033	0.0051	0.0051	0.0071	0.0071	0.0091	0.0091	0.0118
30	150								
32	160	0.0037	0.0055	0.0055	0.0079	0.0079	0.0102	0.0102	0.0134
34	170								
36	180	0.0041	0.0063	0.0063	0.0087	0.0087	0.0114	0.0114	0.0146
38	190								
40	200	0.0047	0.0071	0.0071	0.0098	0.0098	0.0126	0.0126	0.0161
44	220								
48	240	0.0053	0.0079	0.0079	0.0106	0.0106	0.0138	0.0138	0.0177
52	260								
56	280	0.0059	0.0087	0.0087	0.0118	0.0118	0.0154	0.0154	0.0193
60	300								
64	320	0.0065	0.0094	0.0094	0.0130	0.0130	0.0169	0.0169	0.0213
68	340								
72	360	0.0075	0.0106	0.0106	0.0142	0.0142	0.0185	0.0185	0.0232
76	380								
80	400	0.0083	0.0118	0.0118	0.0157	0.0157	0.0205	0.0205	0.0256
84	420								
88	440	0.0091	0.0130	0.0130	0.0173	0.0173	0.0224	0.0224	0.0283
92	460								
96	480	0.0102	0.0146	0.0146	0.0193	0.0193	0.0248	0.0248	0.0311
	530								
	560	0.0114	0.0161	0.0161	0.0213	0.0213	0.0268	0.0268	0.0343
	600								
	630	0.0126	0.0181	0.0181	0.0236	0.0236	0.0299	0.0299	0.0386

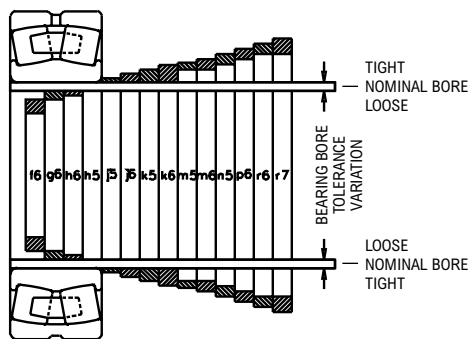
C2 = Internal clearance less than C0

C0 = Internal clearance

C3 = Internal clearance greater than C0

C4 = Internal clearance greater than C3

Shaft Bearing Seat Diameters



Bearing bore tolerances are in accord with the system of tolerancing established by the International Standards Organization (ISO) and adopted by the American Bearing Manufacturers Association (ABMA) and the American National Standards Institute (ANSI).

A system of limits and fits has been established by ISO for shafts. A portion of this system has been adopted by ABMA to provide flexibility in selecting shaft fits. Shaft fits are designated by a lower case letter and a number, such as h6. The letter indicates the location of the shaft tolerance limits with respect to the nominal bearing bore. The number indicates the size of the tolerance zone.

Shaft fits recommended for various types of applications are listed in the table at right. A graphic relationship of various shaft fits is illustrated in the figure at the left.

Many factors influence the proper fit on the bearing inner ring on a shaft. The magnitude of the load and its direction with respect to bearing inner or outer rings are generally the first factors considered in shaft fit selection. The effects of other factors such as vibration, shock, temperature, speed, etc. are of secondary importance but sometimes need to be considered. Where assembly or disassembly requirements are of prime importance special shaft fits may be required.

Appropriate diameter shafting is determined (as shown) from the tables below.

Class of Fit and Shaft Diameters

Bearing Series 22200, 22300, 23000	Nominal bearing bore and shaft diameter		Bearing bore tolerance#	Bearing/Shaft diameter fits*									
				f6		g6		h6		h5		j5	
				Tolerance		Tolerance		Tolerance		Tolerance		Tolerance	
				Fit	Shaft Dia.	Fit	Shaft Dia.	Fit	Shaft Dia.	Fit	Shaft Dia.	Fit	Shaft Dia.
08	1.5748	40.000	+0.0000 -0.0005	.0005L	-0.0010	.0001T	-0.0004	.0005T	0.0000	.0005T	0.0000	.0007T	0.0002
09	1.7717	45.000	+0 -12	.0016L	-0.0016	.0010L	-0.0010	.0006L	-0.0006	.0004L	-0.0004	.0002L	-0.0002
10	1.9685	50.000		13L	-25	3T	-9	12T	+0	12T	+0	18T	6
11	2.1654	55.000	+0.0000 -0.0006	41L	-41	25L	-25	16L	-16	11L	-11	5L	-5
12	2.3622	60.000											
13	2.5591	65.000		.0006L	-0.0012	.0002T	-0.0004	.0006T	0.0000	.0006T	0.0000	.0008T	0.0002
14	2.7559	70.000	+0 -15	.0019L	-0.0019	.0011L	-0.0011	.0007L	-0.0007	.0005L	-0.0005	.0003L	-0.0003
15	2.9528	75.000		15L	-30	5T	-10	15T	+0	15T	+0	21T	6
16	3.1496	80.000		49L	-49	29L	-29	19L	-19	13L	-13	7L	-7
17	3.3465	85.000	+0.0000 -0.0008										
18	3.5433	90.000		.0006L	-0.0014	.0003T	-0.0005	.0008T	0.0000	.0008T	0.0000	.0010T	0.0002
19	3.7402	95.000	+0 -20	.0023L	-0.0023	.0014L	-0.0014	.0009L	-0.0009	.0006L	-0.0006	.0004L	-0.0004
20	3.9370	100.000		16L	-36	8T	-12	20T	+0	20T	+0	26T	6
22	4.3307	110.000		58L	-58	34L	-34	22L	-22	15L	-15	9L	-9
24	4.7244	120.000											
26	5.1181	130.000	+0.0000 -0.0010										
28	5.5118	140.000		.0006L	-0.0016	.0004T	-0.0006	.0010T	0.00000013T	0.0003
30	5.9055	150.000	+0 -25	.0026L	-0.0026	.0016L	-0.0016	.0010L	-0.00100005L	-0.0004
32	6.2992	160.000		18L	-43	11T	-14	25T	+0	32T	7
34	6.6929	170.000		68L	-68	39L	-39	25L	-25	11L	-11
36	7.0866	180.000											
38	7.4803	190.000	+0.0000 -0.0012										
40	7.8740	200.000		.0008L	-0.0020	.0006T	-0.0006	.0012T	0.0000
44	8.6614	220.000	+0 -30	.0032L	-0.0032	.0018L	-0.0018	.0012L	-0.0012
48	9.4488	240.000		20L	-50	15T	-15	30T	+0
52	10.2362	260.000	+0.0000 -0.0014	79L	-79	44L	-44	29L	-29
56	11.0236	280.000		.0008L	-0.0022	.0007T	-0.0007	.0014T	0.0000
60	11.811	300.000	+0 -35	.0034L	-0.0034	.0019L	-0.0019	.0012L	-0.0012
				21L	-56	18T	-17	35T	+0
				88L	-88	49L	-49	32L	-32

1µm = .001 mm

#The arithmetical mean of the largest and smallest single diameter to be within tolerance shown.

Allowable deviations from mean diameter per ANSI/ABMA STD 20, latest printing.

For additional shaft sizes, please consult Rexnord Bearing Engineering for proper fitting practices.

Class of Fit Selection

Operating condition			Examples	Nominal shaft diameter		Class of fit ■	Remarks
				mm	inches		
Inner ring stationary in relation to direction of load.	All loads	Inner ring has to be easily displaced	Wheel on stationary shaft	All diameters		g6	
		Inner ring does not have to be easily displaced	Tension pulleys and rope sheaves			h6	
Direction of load indeterminate or inner ring rotating in relation to direction of load.	Radial load		Electric apparatus, machine tools, pumps, ventilators, industrial trucks	<=40 40—100 100—200	<=1.57 1.57—3.94 3.94—7.88	j6 k6 m6	When greater accuracy is required, use j5, k5 and m5 for j6, k6, and m6 respectively.
	Light load <=0.08C★						
	Normal load >0.08C★ <=0.18C★		Applications in general, electrical motors, turbines pumps, combustion engines, gear transmissions, wood working machines	<=40 40—65 65—100 100—140 140—280 280—500 >500	<=1.57 1.57—2.56 2.56—3.94 3.94—5.52 5.52—11.10 11.10—19.7 >19.7	k5 m5 m6 n6 p6 r6 r7	
	Heavy load >0.18C★		Journal boxes for locomotives & other heavyrail vehicles, traction motors	<=40 40—65 65—100 100—140 140—200 >200	<=1.57 1.57—2.56 2.56—3.94 3.94—5.52 5.52—7.88 >7.88	m5 m6 n6 p6 r6 r7	

Bearing/Shafts Diameter Fits*

j6		k5		k6		m5		m6		n6		p6		r6	
Tolerance		Tolerance		Tolerance		Tolerance		Tolerance		Tolerance		Tolerance		Tolerance	
Fit	Shaft Dia.	Fit	Shaft Dia.	Fit	Shaft Dia.	Fit	Shaft Dia.	Fit	Shaft Dia.	Fit	Shaft Dia.	Fit	Shaft Dia.	Fit	Shaft Dia.
.0009T	0.0004	.0010T	0.0005	.0012T	0.0007	.0013T	0.0008	.0015T	0.001	.0018T	0.0013
.0002L	-.0002	.0001T	0.0001	.0001T	0.0001	.0004T	0.0004	.0004T	0.0004	.0007T	0.0007
23T	11	25T	13	30T	18	32T	20	37T	25	45T	33
5L	-5	2T	2	2T	2	9T	9	9T	9	17T	17
.0010T	0.0004	.0012T	0.0006	.0014T	0.0008	.0016T	0.001	.0018T	0.0012	.0021T	0.0015	.0027T	0.021	.	.
.0003L	-.0003	.0001T	0.0001	.0001T	0.0001	.0005T	0.0005	.0005T	0.0005	.0008T	0.0008	.0014T	0.0014	.	.
22T	12	30T	15	36T	21	39T	24	45T	30	54T	39	66T	51	.	.
7L	-7	2T	2	2T	2	11T	11	11T	11	20T	20	32T	32	.	.
.0013T	0.0005	.0015T	0.0007	.0018T	0.001	.0019T	0.0011	.0022T	0.0014	.0027T	0.0019	.0033T	0.0025	.0037T	0.0029
.0004L	-.0004	.0001T	0.0001	.0001T	0.0001	.0005T	0.0005	.0005T	0.0005	.0010T	0.001	.0016T	0.0016	.0020T	0.002
33T	13	38T	18	45T	25	48T	28	55T	35	65T	45	79T	59	93T	73
9L	-9	3T	3	3T	3	13T	13	13T	13	23T	23	37T	37	51T	51
.0016T	0.006	.0018T	0.0008	.0021T	0.0011	.0023T	0.0013	.0026T	0.0016	.0032T	0.002	.0038T	0.0028	.0045T	0.0035
.0004L	-.0004	.0001T	0.0001	.0001T	0.0001	.0006T	0.0006	.0006T	0.0006	.0012T	0.0011	.0018T	0.0018	.0025T	0.0025
39T	14	46T	21	53T	28	58T	33	65T	40	77T	52	93T	68	115T	90
11L	-11	3T	3	3T	3	15T	15	15T	15	27T	27	43T	43	65T	65
.0019T	0.0007	.0022T	0.001	.0026T	0.0014	.0026T	0.0014	.0030T	0.0018	.0038T	0.0026	.0044T	0.0032	.0054T	0.0042
.0005L	-.0005	.0002T	0.0002	.0002T	0.0002	.0006T	0.0006	.0006T	0.0006	.0014T	0.0014	.0020T	0.002	.0030T	0.003
46T	16	54T	24	63T	33	67T	37	76T	46	90T	60	109T	79	136T	106
16L	-16	4T	4	4T	4	17T	17	17T	17	31T	31	50T	50	77T	77
.0021T	0.0007	.0025T	0.0011	.0028T	0.0014	.0031T	0.0017	.0034T	0.002	.0040T	0.0026	.0048T	0.0034	.0061T	0.0047
.0006L	-.0006	.0002T	0.0002	.0002T	0.0002	.0008T	0.0008	.0008T	0.0008	.0014T	0.0014	.0022T	0.0022	.0035T	0.0035
51T	16	62T	27	71T	36	78T	43	87T	52	101T	66	123T	88	161T	126
16L	-16	4T	4	4T	4	20T	20	20T	20	34T	34	56T	56	94T	94

* Symbol L indicates a loose or clearance fit; Symbol T indicates a tight or interference fit.

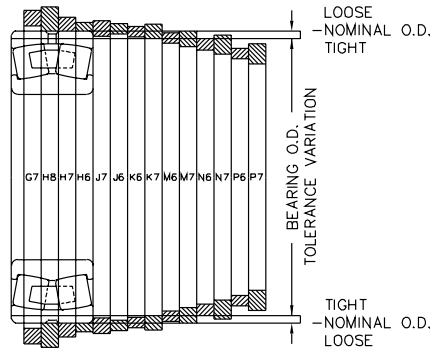
■ For solid steel shafts.

★ = basic load rating of bearing.

The appropriate shaft diameter for any class of fit can be easily determined by applying the shaft tolerance to the nominal shaft diameter. Example: (Using basic bearing size 08 and fit class f6).

	inches		mm			
Nominal shaft diameter	=	1.5748	1.5748	=	40	40
Shaft diameter tolerance	=	-0.001	-0.0016	=	-0.025	-0.041
Resultant shaft diameter	=	1.5738	1.5732	=	39.975	39.959

Housing Bearing Seat Diameters



Bearing outside diameter tolerances are in accord with the system of tolerancing established by the International Standards Organization (ISO) and adopted by the American Bearing Manufacturers Association (ABMA) and the American National Standards Institute (ANSI).

A system of limits and fits has been established by ISO for shafts. A portion of this system has been adopted by ABMA to provide flexibility in selecting shaft fits. Housing fits are designated by a capital letter and a number, such as H7. The letter indicates the location of the housing bore tolerance limits with respect to the nominal bearing O.D. The number indicates the size of the tolerance zone.

Housing fits recommended for various types of applications are listed in the table at right. A graphic relationship of various housing fits is illustrated in the figure at the left.

The class of fit is determined by nature of loading (oscillating, vibrating, reversing, etc.), axial movement requirements, temperature conditions, housing material and cross section of housing.

Shaft expansion increases bearing center distances and requires all but one bearing on a shaft to be movable axially in the housing. In most bearings the outer rings are subjected to stationary loads which permit a loose housing fit.

Operating temperature may affect the housing fit, as the housing may dissipate heat rapidly and not expand with the outer ring. However, the loose fit must never be greater than necessary. Excessive looseness results in less accurate shaft centering and additional ring deformation under load.

The appropriate housing bores are determined (as shown) from the tables below.

Class of Fit and Housing Bores

Bearing Series					Nominal bearing O.D. and housing bore		Bearing bore tolerance #	Bearing/Housing diameter fits ^A									
								G7		H8		H7		H6		J7	
222, 232	223	230	231	Basic Size		inches	mm	Tolerance		Tolerance		Tolerance		Tolerance		Tolerance	
					Fit			Housing Bore	Fit	Housing Bore	Fit	Housing Bore	Fit	Housing Bore	Fit	Housing Bore	
09	3.3465	85.000	+0.000	-0.006	.0005L	0.0005	.0000	+0.000	.0000	+0.000	.0000	+0.000	.0005T	-0.0005
10	08	3.5433	90.000			.0025L	0.0019	.0028L	0.0022	.0020L	0.0014	.0015L	0.0009	.0015L	0.0009
11	09	3.9370	100.000	+0	-15	12L	12	0	+0	0	+0	0	+0	13T	-13
12	10	4.3307	110.000			62L	47	69L	54	50L	35	37L	22	37L	22
13	11	4.7244	120.000												
14	4.9312	125.000	+0.000	-0.008	.0006L	0.0006	.0000	+0.000	.0000	+0.000	.0000	+0.000	.0006T	-0.0006
15	12	5.1181	130.000			.0030L	0.0022	.0033L	0.0025	.0024L	0.0016	.0018L	0.0010	.0018L	0.0010
16	13	5.5118	140.000	+0	-20	14L	14	0	+0	0	+0	0	+0	14T	-14
17	14	5.9055	150.000			74L	54	83L	63	60L	40	45L	25	46L	26
18	15	6.2992	165.000	+0.000	-0.010	.0006L	0.0006	.0000	+0.000	.0000	+0.000	.0000	+0.000	.0006T	-0.0006
19	16	6.6929	170.000			.0032L	0.0022	.0035L	0.0025	.0026L	0.0016	.0020L	0.0010	.0020L	0.0010
20	17	24	22	7.0866	180.000	+0	-25	14L	14	0	+0	0	+0	0	+0	14T	-14
..	18	7.4803	190.000			79L	54	88L	63	65L	40	50L	25	51L	26
22	19	26	24	7.8740	200.000	+0.000	-0.012										
..	..	28	26	8.2677	210.000			.0006L	0.0006	.0000	+0.000	.0000	+0.000	.0000	+0.000	.0007T	-0.0007
24	20	8.4646	215.000			.0036L	0.0024	.0040L	0.0028	.0030L	0.0018	.0024L	0.0012	.0023L	0.0011
..	..	30	28	8.8583	225.000	+0	-30	15L	15	0	+0	0	+0	0	+0	16T	-16
26	9.0551	230.000			91L	61	102L	72	76L	46	59L	29	60L	30
..	22	32	..	9.4488	240.000												
28	30	9.8425	250.000												
..	24	34	..	10.2362	260.000	+0.000	-0.014										
30	32	10.6299	270.000			.0007L	0.0007	.0000	+0.000	.0000	+0.000	.0000	+0.000	.0007T	-0.0007
..	26	36	34	11.0236	280.000			.0041L	0.0027	.0044L	0.0030	.0034L	0.0020	.0026L	0.0012	.0027L	0.0013
32	..	38	..	11.4173	290.000	+0	-35	17L	17	0	+0	0	+0	0	+0	16T	-16
..	28	..	36	11.8110	300.000			104L	69	116L	81	87L	52	67L	32	71L	36
34	..	40	..	12.2047	310.000												
36	30	..	38	12.5984	320.000	+0.000	-0.016										
38	32	44	40	13.3858	340.000			.0007L	0.0007	.0000	+0.000	.0000	+0.000	.0000	+0.000	.0007L	-0.0007
40	34	48	..	14.1732	360.000			.0045L	0.0029	.0051L	0.0035	.0038L	0.0022	.0030L	0.0014	.0031L	0.0015
..	44	14.5669	370.000	+0	-40	18L	18	0	+0	0	+0	0	+0	18T	-18
..	36	14.9606	380.000			115L	75	129L	89	97L	57	76L	36	79L	39
44	38	52	48	15.7480	400.000												
..	40	56	..	16.5354	420.000	+0.000	-0.018	.0008L	0.0008	.0000	+0.000	.0000	+0.000	.0000	+0.000	.0009T	-0.0009
48	17.3228	440.000			.0051L	0.0033	.0056L	0.0038	.0043L	0.0025	.0034L	0.0016	.0034L	0.0016
..	44	60	..	18.1102	460.000	+0	-45	20L	20	0	+0	0	+0	0	+0	20T	-20
..			128L	83	142L	97	108L	63	85L	40	88L	43

The arithmetical mean of the largest and smallest single diameter to be within tolerance shown.

Allowable deviations from mean diameter per ANSI/ABMA STD 20, latest printing.

^A Symbol L indicates a loose or clearance fit. Symbol T indicates a tight or interference fit.

The appropriate housing bore for any class of fit can be easily determined by applying the housing tolerance to the nominal housing bore.

Example: (Using basic bearing size 09 and fit class G7).

For larger bearing sizes please consult Rexnord Bearing Engineering for proper housing fit practices.

			inches			mm
Nominal housing bore	=	3.3465	3.3465	=	85.000	85.000
Shaft bore tolerance	=	+ .0005	+ .0019	=	+ 0.012	+ 0.047
Resultant housing bore	=	3.3470	3.3484	=	85.012	85.047

Class of Fit Selection

Housing Construction	Operating Condition		Examples	Class of Fit	Remarks		
Housing not split radially	Housing rotating in relation to direction of load	Heavy loads on bearings in thin-walled housing	Supporting wheels in cranes, wheel hubs with roller bearings, crank bearings	P6*	Outer ring not axially displaceable		
		Normal and heavy loads	Wheel hubs with roller bearings, crank bearings	N6*			
		Light loads	Conveyor rollers, rope sheaves, tension pulleys	M6*			
Housing split or housing not split radially	Direction of load indeterminate	Heavy shock loads	Electrical fraction motors	K6*	Outer ring, as a rule, not axially displaceable		
		Heavy and normal loads where outer ring does not have to be axially displaceable	Electrical motors, pumps, crankshaft main bearings				
	Housing stationary in relation to direction of load	Normal and light loads where displaceability of outer ring is desirable	Journal boxes for rail vehicles	J6*	Outer ring as a rule, axially displaceable		
		Shock loads, a temporary complete unloading					
		All loads	Housing not split radially	Bearing applications in general, journal boxes for rail vehicles		H6*	Outer ring easily displaceable axially
			Housing split radially	Line shafting		H7	
Heat supplied through shaft	Dryer cylinders	G7					

Bearing/Housing Diameter Fits ^A

J6		K6		K7		M6		M7		N6		N7		P7	
Tolerance		Tolerance		Tolerance		Tolerance		Tolerance		Tolerance		Tolerance		Tolerance	
Fit	Housing Bore	Fit	Housing Bore	Fit	Housing Bore	Fit	Housing Bore	Fit	Housing Bore	Fit	Housing Bore	Fit	Housing Bore	Fit	Housing Bore
.002T	-.002	.0007T	-.0007	.0010T	-.0010	.0012T	-.0012	.0014T	-.0014	.0016T	-.0016	.0018T	-.0018	.0025T	-.0025
.0013L	0.0007	.0008L	0.0002	.0010L	0.0004	.0003L	-.0003	.0006L	0	.0001T	-.0007	.0002L	-.0004	.0005T	-.0011
6T	-6	18T	-18	25T	-25	28T	-28	35T	-35	38T	-38	45T	-45	59T	-59
31L	16	19L	4	25L	10	9L	-6	15L	0	1T	-16	5L	-10	9T	-24
.0003T	0.0003	.0008T	-.0008	.0011T	-.0011	.0013T	-.0013	.0016T	-.0016	.0019T	-.0019	.0022T	-.0022	.0028T	-.0028
.0015L	0.0007	.0010L	0.0002	.0013L	0.0005	.0005L	-.0003	.0008L	0	.0001T	-.0009	.0002L	-.0006	.0004T	-.0012
7T	-7	21T	-21	28T	-28	33T	-33	40T	-40	45T	-45	52T	-52	68T	-68
38L	18	24L	4	32L	12	12L	-8	20L	0	0T	-20	8L	-12	8T	-28
.0003T	-.0003	.0008T	-.0008	.0011T	-.0011	.0013T	-.0013	.0016T	-.0016	.0019T	-.0019	.0022T	-.0022	.0028T	-.0028
.0017L	0.0007	.0012L	0.0002	.0015L	0.0005	.0007L	-.0003	.0010L	0	.0001L	-.0009	.0004L	-.0006	.0002T	-.0012
7T	-7	21T	-21	28T	-28	33T	-33	40T	-40	45T	-45	52T	-52	68T	-68
43L	18	29L	4	37L	12	17L	-8	25L	0	5L	-20	13L	-12	3T	-28
.0003T	-.0003	.0010T	-.0010	.0013T	-.0013	.0015T	-.0015	.0018T	-.0018	.0022T	-.0022	.0026T	-.0026	.0032T	-.0032
.0021L	0.0009	.0014L	0.0002	.0017L	0.0005	.0009L	-.0003	.0012L	0	.0002L	-.0010	.0004L	-.0008	.0002T	-.0014
7T	-7	24T	-24	33T	-33	37T	-37	46T	-46	51T	-51	60T	-60	79T	-79
52L	22	35L	5	43L	13	22L	-8	30L	0	8L	-22	16L	-14	3T	-33
.0003T	-.0003	.0010T	-.0010	.0014T	-.0014	.0016T	-.0016	.0020T	-.0020	.0023T	-.0023	.0028T	-.0028	.0034T	-.0034
.0023L	0.0009	.0016L	0.0002	.0020L	0.0006	.0010L	-.0004	.0014L	0	.0003L	-.0011	.0006L	-.0008	0	-.0014
7T	-7	22T	-27	36T	-36	41T	-41	52T	-52	57T	-57	66T	-66	88T	-88
60L	25	40L	5	51L	16	26L	-9	35L	0	10L	-25	21L	-14	1T	-36
.0003T	-.0003	.0012T	-.0012	.0016T	-.0016	.0018T	-.0018	.0022T	-.0022	.0026T	-.0026	.0030T	-.0030	.0039T	-.0039
.0027L	0.0011	.0018L	0.0002	.0022L	0.0006	.0012L	-.0004	.0016L	0	.0004L	-.0012	.0008L	-.0008	.0001T	-.0017
7T	-7	29T	-29	40T	-40	46T	-46	57T	-57	62T	-62	73T	-73	98T	-98
69L	29	47L	7	57L	17	30L	-10	40L	0	14L	-26	26L	-16	1T	-41
.0003T	-.0003	.0012T	-.0012	.0018T	-.0018	.0020T	-.0020	.0025T	-.0025	.0028T	-.0028	.0034T	-.0034	.0044T	-.0044
.0031L	0.0013	.0022L	0.0004	.0025L	0.0007	.0014L	-.0004	.0018L	0	.0006L	-.0012	.0009L	-.0009	.0001T	-.0019
7T	-7	32T	-32	45T	-45	50T	-50	63T	-63	67T	-67	80T	-80	108T	-108
78L	33	53L	8	63L	18	35L	-10	45L	0	18L	-27	28L	-17	0	-45

■ For cast iron or steel housings. For housings of light metal, select tolerances which give slightly tighter fits than those shown.

* Where wider tolerances are permissible P7, N7, M7, K7, J7 and H7 may be used for P6, N6, M6, K6, J6 and H6 respectively.

Series A20000S Selection Guide

A20000S single row angular contact spherical roller bearings are suitable for a wide variety of mounting arrangements. In the application of these bearings, it is important to consider that radial loads produce a thrust reaction which must be opposed by another force... usually the thrust reaction from another bearing. This force maintains the bearing rings in their correct operating position.

Normally, two single row angular contact bearings are mounted opposed to one another on a common shaft. As thrust or thrust reactions are always present, it is advisable to calculate both bearing lives concurrently.

Steps for Selection

Step 1

Determine an appropriate L10 design life.

Type of service	Operating time, hours per year	Design life, years	L10 design life, hours
Light seasonal usage	500 to 750	3-5	3,000
Heavy seasonal usage	1,400 to 1,600	4-6	8,000
Industrial—8 hour shift	2,000	10	20,000
Industrial—16 hour shift	4,000	10	40,000
Industrial—continuous	8,700	10	80,000 to 100,000
Continuous—high reliability	—	—	120,000 to 300,000

Step 2

Determine a required $\left(\frac{C}{P}\right)$ from Table 1.

Step 3

Determine a required shaft diameter and make a temporary selection for each bearing to fit this shaft.

Step 4

Calculate each induced thrust reaction TF from the radial loads Fr on each bearing.

$$TF = \frac{0.5 Fr}{Y_2}$$

This reaction is directed along the shaft and tends to separate the individual inner ring and roller assemblies from their outer rings.

The selection procedures and rating formulas shown here are in agreement with The American Bearing Manufacturers Association Standards and ANSI/ ABMA STD 11-1990. Ratings are based on fatigue life. The Rating Life L10 or fatigue life at 90% reliability is the usual basis for bearing selection.

To assure a satisfactory bearing application, fitting practice, mounting, lubrication, sealing, static rating, housing strength, operating conditions and maintenance must be considered.

Step 5

Calculate resultant bearing thrust load Fa.

$$F_a = T_f + T$$

Tf is the thrust reaction from the opposite single row angular contact bearing. The applied thrust load T is positive (+) if in the same direction as Tf, and negative (-) if in the opposite direction. If Fa is negative, substitute zero for Fa.

Step 6

Calculate the ratio of the resultant bearing thrust load Fa to the radial load Fr for each bearing.

Step 7

Calculate the equivalent radial load P for both trial bearings.

$$P = XFr + YFa$$

If $\frac{F_a}{F_r}$ is equal to or less than e, then

$$P = X_1 Fr + Y_1 Fa \quad \text{where} \quad \begin{matrix} X_1 = 1.0 \\ Y_1 = 0 \end{matrix}$$

If $\frac{F_a}{F_r}$ is greater than e, then $P = X_2 Fr + Y_2 Fa$.

For values of e, X2, and Y2, see the bearing rating table.

Step 8

Calculate the required C rating of each bearing to verify the trial selections.

required $C = \left(\frac{C}{P}\right) P$ using $\left(\frac{C}{P}\right)$ from Step 2

Consult the bearing rating table to see if the selected bearings meet or exceed the required C in each case.

Selection

Symbols for formulas:

C = basic load rating, pounds (or newtons) n = speed, revolutions per minute
 Co = static load rating, pounds (or newtons) P = equivalent radial load, pounds (or newtons)
 e = a reference value
 Fa = thrust load, pounds (or newtons) X = radial factor
 Fr = radial load, pounds (or newtons) Y = thrust factor
 L10 = rating life, hours

Table 1 • Relation of L₁₀ life and speed to $\left(\frac{C}{P}\right)$

Bearing Life Hours L10	Speed, n									
	50	100	200	300	400	500	600	700	800	
3000	1.93	2.38	2.93	3.31	3.61	3.86	4.07	4.27	4.44	
4000	2.11	2.59	3.19	3.61	3.93	4.20	4.44	4.65	4.84	
5000	2.25	2.77	3.42	3.86	4.20	4.50	4.75	4.97	5.18	
6000	2.38	2.93	3.61	4.07	4.44	4.75	5.02	5.25	5.47	
8000	2.59	3.19	3.93	4.44	4.84	5.18	5.47	5.73	5.96	
10000	2.77	3.42	4.20	4.75	5.18	5.54	5.85	6.12	6.37	
12000	2.93	3.61	4.44	5.02	5.47	5.85	6.18	6.47	6.73	
14000	3.07	3.78	4.65	5.25	5.73	6.12	6.47	6.77	7.05	
16000	3.19	3.93	4.84	5.47	5.96	6.37	6.73	7.05	7.34	
18000	3.31	4.07	5.02	5.66	6.18	6.60	6.97	7.30	7.60	
20000	3.42	4.20	5.18	5.85	6.37	6.81	7.20	7.54	7.85	
25000	3.65	4.50	5.54	6.25	6.81	7.29	7.70	8.06	8.39	
30000	3.86	4.75	5.85	6.60	7.20	7.70	8.13	8.51	8.86	
35000	4.04	4.97	6.12	6.92	7.54	8.06	8.51	8.92	9.28	
40000	4.20	5.18	6.37	7.20	7.85	8.39	8.86	9.28	9.66	
45000	4.36	5.36	6.60	7.46	8.13	8.69	9.18	9.61	10.00	
50000	4.50	5.54	6.81	7.70	8.39	8.97	9.48	9.92	10.30	
60000	4.75	5.85	7.20	8.13	8.86	9.48	10.00	10.50	10.90	
70000	4.97	6.12	7.54	8.51	9.28	9.92	10.50	11.00	11.40	
80000	5.18	6.37	7.85	8.86	9.66	10.30	10.90	11.40	11.90	
90000	5.36	6.60	8.13	9.18	10.00	10.70	11.30	11.80	12.30	
100000	5.54	6.81	8.39	9.48	10.30	11.00	11.70	12.20	12.70	
150000	6.25	7.70	9.48	10.70	11.70	12.50	13.20	13.80	14.40	
200000	6.81	8.39	10.30	11.70	12.70	13.60	14.40	15.00	15.70	

	Speed, n									
	900	1000	1200	1500	1800	2400	3000	3600	6000	
3000	4.60	4.75	5.02	5.36	5.66	6.18	6.60	6.97	8.13	
4000	5.02	5.18	5.47	5.85	6.18	6.73	7.20	7.60	8.86	
5000	5.36	5.54	5.85	6.25	6.60	7.20	7.70	8.13	9.48	
6000	5.66	5.85	6.18	6.60	6.97	7.60	8.13	8.59	10.00	
8000	6.18	6.37	6.73	7.20	7.60	8.29	8.86	9.36	10.90	
10000	6.60	6.81	7.20	7.70	8.13	8.86	9.48	10.00	11.70	
12000	6.97	7.20	7.60	8.13	8.59	9.36	10.00	10.60	12.30	
14000	7.30	7.54	7.96	8.51	8.99	9.80	10.50	11.10	12.90	
16000	7.60	7.85	8.29	8.86	9.36	10.20	10.90	11.50	13.40	
18000	7.88	8.13	8.59	9.18	9.70	10.60	11.30	11.90	13.90	
20000	8.13	8.39	8.86	9.48	10.00	10.90	11.70	12.30	14.40	
25000	8.69	8.97	9.48	10.10	10.70	11.70	12.50	13.20	15.40	
30000	9.18	9.48	10.00	10.70	11.30	12.30	13.20	13.90	16.20	
35000	9.61	9.92	10.50	11.20	11.80	12.90	13.80	14.60	17.00	
40000	10.00	10.30	10.90	11.70	12.30	13.40	14.40	15.20	17.70	
45000	10.40	10.70	11.30	12.10	12.80	13.90	14.90	15.70	18.30	
50000	10.70	11.00	11.70	12.50	13.20	14.40	15.40	16.20	18.90	
60000	11.30	11.70	12.30	13.20	13.90	15.20	16.20	17.10	20.00	
70000	11.80	12.20	12.90	13.80	14.60	15.90	17.00	17.90	20.90	
80000	12.30	12.70	13.40	14.40	15.20	16.50	17.70	18.70	21.80	
90000	12.80	13.20	13.90	14.90	15.70	17.10	18.30	19.40	22.60	
100000	13.20	13.60	14.40	15.40	16.20	17.70	18.90	20.00	23.30	
150000	14.90	15.40	16.20	17.30	18.30	20.00	21.40	22.60	26.30	
200000	16.20	16.70	17.70	18.90	20.00	21.80	23.30	24.60	28.70	

Basic Formula

$$\left(\frac{C}{P}\right) = \left(\frac{L_{10} \times n \times 60}{1,000,000}\right)^{3/10}$$

$$L_{10} = \frac{\left(\frac{C}{P}\right)^{10/3} \times 1,000,000}{n \times 60}$$

Life Expectancy (pair of bearings)

To calculate the Rating Life L₁₀ of any pair of selected or trial bearings:

Step 1

Calculate each induced thrust reaction T_F from the radial loads F_r on each bearing.

$$T_F = \frac{0.5 F_r}{Y_2}$$

This reaction is directed along the shaft and tends to separate the individual inner ring and roller assemblies from their outer rings.

Step 2

Calculate each resultant bearing thrust load F_a.

$$F_a = T_F + T$$

T_F is the thrust reaction from the opposite single row angular contact bearing. The applied thrust load T is positive (+) if in the same direction as T_F, and negative (-) if in the opposite direction. If F_a is negative, substitute zero for F_a.

Step 3

Calculate the ratio of the resultant bearing thrust load F_a to the radial load F_r for each bearing.

Step 4

Calculate the equivalent radial load P for both trial bearings. P = XFr + YFa

If $\frac{F_a}{F_r}$ is equal to or less than e, then
 $P = X1Fr + Y1Fa$ where

If $\frac{F_a}{F_r}$ is greater than e, then
 $P = X2Fr + Y2Fa$.

For values of e, X₂, and Y₂ see the bearing rating table.

Step 5

Calculate each ratio of the bearing basic load rating C to its equivalent radial load.

$$\left(\frac{C}{P}\right)$$

Step 6

Approximate life expectancy of each bearing from Table 1.

Life Adjustment

The Rating Life, L₁₀, may be modified for some applications in accordance with the formula

$$L_n = a_1 a_2 a_3 L_{10}$$

where L_n = Adjusted life for (100-n) % reliability,

a₁ = Life adjustment factor for reliability

a₂ = Life adjustment factor for material and processing

a₃ = Life adjustment factor for operating conditions.

For most normal applications, all factors will be taken as 1, and the Rating Life used as the selection basis or life estimate. In addition, as long as standard catalog bearings are used, a₂ will be normally set equal to one. The factor a₃ covers such things as lubrication, misalignment, and temperature.

Some conditions that could yield a₃ significantly different than unity include speeds less than 20000 DN or greater than 200000 DN, temperatures below -40°F (-40°C) or above 275°F (135°C). For other possible conditions, as well as additional information on life adjustment factors, consult Rexnord Bearing Division.

Table 2 • Series A2000S Load Ratings and Speed Limits

Bearing number	Weight		Co Static Load Rating		C Basic Load Rating		Approx. Speed Limit RPM [^]	e	X2	Y2
	Kilograms	pounds	newtons	pounds	newtons	pounds				
A22100S	0.2	0.5	36 500	8210	33 300	7480	7100	0.51	0.40	1.17
A22150S	0.3	0.6	46 600	10500	37 800	8510	5700	0.44	0.40	1.37
A22196S	0.5	1.1	73 800	16600	55 100	12400	4500	0.40	0.40	1.49
A23225S	0.6	1.4	98 800	22200	68 500	15400	4000	0.40	0.40	1.49
A22262S	0.9	2.0	136 100	30600	93 200	21000	3500	0.37	0.40	1.61
A23275S	2.1	4.7	187 700	42200	150 300	33800	2850	0.40	0.40	1.49
A22300S	1.4	3.0	159 200	35800	108 500	24400	3100	0.38	0.40	1.59
A23300S	2.3	5.0	201 500	45300	132 600	29800	2650	0.38	0.40	1.57
A23334S	2.0	4.4								
A22413S	4.1	9.0	395 100	88800	244 700	55000	2100	0.38	0.40	1.60

Please consult for availability.

[^] For oil lubrication only. For grease lubrication, use 75% of these values.

Table 3 • Series A20000, A20000M Load Ratings and Speed Limits

Bearing Number	Weight		Co Static Load Rating		C Basic Load Rating		Approximate speed limit RPM*	e	$\frac{F_a}{F_r} \leq e$		$\frac{F_a}{F_r} > e$	
	kilograms	pounds	newtons	newtons	newtons	pounds			X1	Y1	X2	Y2
A22100	0.4	1.0										
A22100M	0.4	1.0	66 100	14900	51 200	11500	7100	0.51	1.00	1.32	0.67	1.96
A22112	0.4	0.9										
A22112M	0.4	0.9										
A22118	0.6	1.3	80 500	18100	60 900	13700	6200	0.48	1.00	1.40	0.67	2.08
A22118M	0.6	1.4										
A22125	0.5	1.1										
A22125M	0.5	1.2										
A22137	0.6	1.3	93 200	20900	64 900	14600	5700	0.44	1.00	1.54	0.67	2.29
A22137M	0.6	1.4										
A22150	0.5	1.2										
A22150M	0.6	1.3										
A22177	0.9	2.0	127 700	28700	89 800	20200	4800	0.45	1.00	1.51	0.67	2.25
A22177M	0.9	2.0										
A22196	1.0	2.1	147 700	33200	94 300	21200	4500	0.40	1.00	1.68	0.67	2.50
A22196M	1.0	2.3										
A23196	1.4	3.1	189 000	42500	130 300	29300	4200	0.45	1.00	1.50	0.67	2.24
A23196M	1.5	3.3										
A24196	2.0	4.3	245 500	55200	164 600	37000	3850	0.48	1.00	1.39	0.67	2.07
A24196M	2.1	4.7										
A23200	1.4	3.2										
A23200M	1.5	3.3	197 500	44400	117 400	26400	4000	0.40	1.00	1.68	0.67	2.50
A23225	1.3	2.8										
A23225M	1.3	2.9										
A24236	1.8	3.9	238 000	53500	139 700	31400	3600	0.38	1.00	1.80	0.67	2.68
A24236M	2.0	4.3										
A22262	1.9	4.2	272 700	61300	159 700	35900	3500	0.37	1.00	1.81	0.67	2.70
A23262	2.9	6.5	249 400	67300	194 400	43700	3250	0.42	1.00	1.62	0.67	2.42
A23262M	3.1	6.9										
A23275	4.2	9.3	375 000	84300	257 500	57900	2850	0.40	1.00	1.67	0.67	2.49
A23275M	4.4	9.8										
A22275	3.0	6.6	318 000	71500	185 900	41800	3100	0.38	1.00	1.79	0.67	2.67
A22275M	3.1	6.8										
A22295	2.7	6.0										
A22295M	2.8	6.2										
A23334	4.0	8.9	403 400	90700	226 800	51000	2650	0.38	1.00	1.77	0.67	2.64
A23334M	4.3	9.4										
A22343	4.3	9.4	516 000	116000	274 000	61600	2600	0.43	1.00	1.57	0.67	2.33
A22343M	4.4	9.8										
A22351	4.9	10.9										
A22351M	5.1	11.3										
A22362	4.7	10.4										
A22362M	4.9	10.8										
A24374	7.5	16.0	609 400	137000	351 800	79100	2200	0.36	1.00	1.88	0.67	2.79
A22354	9.6	21.1										
A22354M	10.0	22.1										
A22400	8.6	18.9	790 200	178000	419 400	94300	2100	0.38	1.00	1.80	0.67	2.68
A22400M	8.8	19.3										
A22413	8.4	18.6										
A22413M	8.7	19.1										
A23472	13.6	30.0	944 700	212000	520 400	117000	1800	0.37	1.00	1.83	0.67	2.72

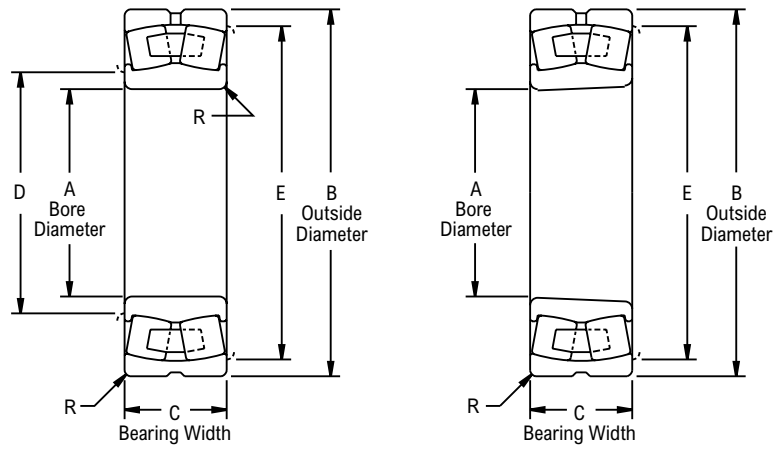
* For oil lubrication only. For grease lubrication, use 75% of these values.

22200LB, 22200LBK



Product Features

- Cylindrical or Tapered bore
- Roller riding retainers
- Self-aligning
- High Capacity
- See Features and Benefits for additional info on page 256.



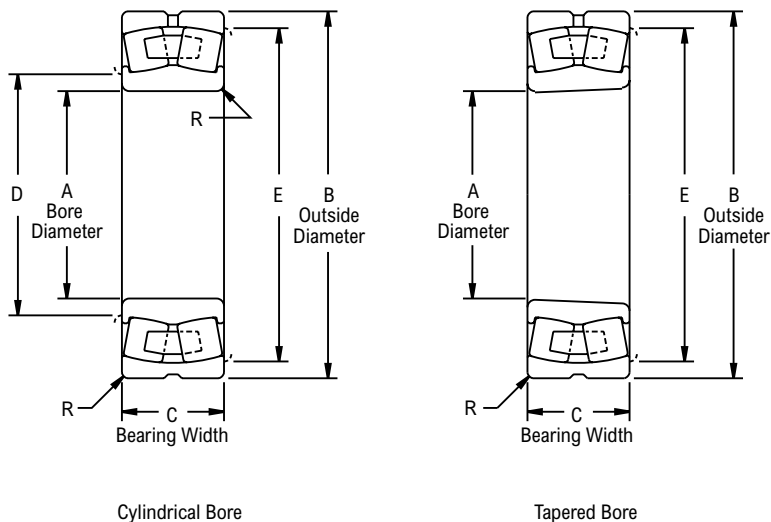
Cylindrical Bore

Tapered Bore

Bearing Dimensions

Cylindrical Part Number	Tapered Part Number	A Bore Diameter	B Outside Diameter	C Bearing Width	D	E	R	Approx. Weight
22209LBC3	22209LBKC3	1.7717 45.00	3.3465 85.00	0.9055 23.00	2.10 53	3.00 76	0.039 1.00	1.30
22210LBC3	22210LBKC3	1.9685 50.00	3.5433 90.00	0.9055 23.00	2.30 58	3.20 81	0.039 1.00	1.40
22211LBC3	22211LBKC3	2.1654 55.00	3.9370 100.00	0.9843 25.00	2.60 66	3.60 91	0.059 1.50	1.90
22212LBC3	22212LBKC3	2.3622 60.00	4.3307 110.00	1.1024 28.00	2.80 71	4.00 102	0.059 1.50	2.60
22213LBC3	22213LBKC3	2.5591 65.00	4.7244 120.00	1.2205 31.00	2.90 74	4.40 112	0.059 1.50	3.40
22214LBC3	22214LBKC3	2.7559 70.00	4.9213 125.00	1.2205 31.00	3.10 79	4.60 117	0.059 1.50	3.70
22215LBC3	22215LBKC3	2.9528 75.00	5.1181 130.00	1.2205 33.00	3.30 84	4.80 122	0.059 1.50	3.90
22216LBC3	22216LBKC3	3.1496 80.00	5.5118 140.00	1.2992 36.00	3.50 89	5.10 130	0.079 2.00	4.90
22217LBC3	22217LBKC3	3.3465 85.00	5.9055 150.00	1.4173 40.00	3.70 94	5.50 140	0.079 2.00	6.10
22218LBC3	22218LBKC3	3.5433 90.00	6.2992 160.00	1.5748 43.00	3.90 99	5.90 150	0.079 2.00	7.60
22219LBC3	22219LBKC3	3.7402 95.00	6.6929 170.00	1.6929 46.00	4.20 107	6.20 157	0.079 2.00	9.50
22220LBC3	22220LBKC3	3.9370 100.00	7.0866 180.00	1.8110 53.00	4.40 112	6.60 168	0.079 2.00	11.40
22222LBC3	22222LBKC3	4.3307 110.00	7.8740 200.00	2.0866 58.00	4.80 122	7.40 188	0.079 2.00	16.60
22224LBC3	22224LBKC3	4.7244 120.00	8.4646 215.00	2.2835 64.00	5.20 132	8.00 203	0.079 2.00	20.20
22226LBC3	22226LBKC3	5.1181 130.00	9.0551 230.00	2.5197 64.00	5.70 145	8.50 216	0.098 2.50	25.10
22228LBC3	22228LBKC3	5.5118 140.00	9.8425 250.00	2.6772 68.00	6.10 155	9.30 236	0.098 2.50	32.40

Continued...



Continued...

Bearing Dimensions

Cylindrical Part Number	Tapered Part Number	A Bore Diameter	B Outside Diameter	C Bearing Width	D	E	R	Approx. Weight
22230LBC3	22230LBK3	5.9055	10.6299	2.8740	6.50	10.10	0.098	40.90
		<i>150.00</i>	<i>270.00</i>	<i>73.00</i>	<i>165</i>	<i>257</i>	<i>2.50</i>	
22232LBC3	22232LBK3	6.2992	11.4173	3.1496	6.90	10.90	0.098	52.00
		<i>160.00</i>	<i>290.00</i>	<i>80.00</i>	<i>175</i>	<i>277</i>	<i>2.50</i>	
22234LBC3	22234LBK3	6.6929	12.2047	3.3858	7.40	11.50	0.118	64.60
		<i>170.00</i>	<i>310.00</i>	<i>86.00</i>	<i>188</i>	<i>292</i>	<i>3.00</i>	
22236LBC3	22236LBK3	7.0866	12.5984	3.3858	7.80	11.90	0.118	67.40
		<i>180.00</i>	<i>320.00</i>	<i>86.00</i>	<i>198</i>	<i>302</i>	<i>3.00</i>	
22238LBC3	22238LBK3	7.4803	13.3858	3.6220	8.20	12.70	0.118	81.90
		<i>190.00</i>	<i>340.00</i>	<i>92.00</i>	<i>208</i>	<i>323</i>	<i>3.00</i>	
22240LBC3	22240LBK3	7.8740	14.1732	3.8583	8.60	13.50	0.118	95.00
		<i>200.00</i>	<i>360.00</i>	<i>98.00</i>	<i>218</i>	<i>343</i>	<i>3.00</i>	
22244LBC3	22244LBK3	8.6614	15.7480	4.2520	9.40	15.10	0.118	133.00
		<i>220.00</i>	<i>400.00</i>	<i>108.00</i>	<i>239</i>	<i>384</i>	<i>3.00</i>	
22248LBC3	22248LBK3	9.4488	17.3228	4.7244	10.60	16.30	0.157	175.70
		<i>240.00</i>	<i>440.00</i>	<i>120.00</i>	<i>269</i>	<i>414</i>	<i>4.00</i>	

Additional Notes

Please call 1-866-REXNORD for availability

Tapered bore, 1:12 on diameter

Dimension "R" is the largest fillet radius that will clear bearing corners

For the Selection Guide Load Ratings and Speed Limits, see the Link-Belt Spherical Roller Bearings Engineering section on pages 258 - 273.

For shaft bearing seat diameters, see Link-Belt Spherical Roller Bearings Shaft & Housing Seat Diameters section on pages 266 - 269.

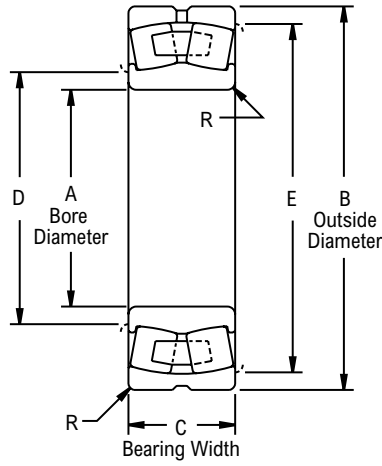
Note: Dimensions subject to change. Certified dimensions of ordered material furnished on request.

22300LB, 22300LBK

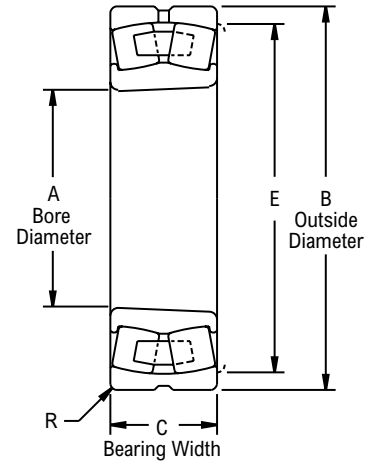


Product Features

- Cylindrical or Tapered bore
- Roller riding retainers
- Self-aligning
- Extra high capacity
- See Features and Benefits for additional info on page 256.



Cylindrical Bore

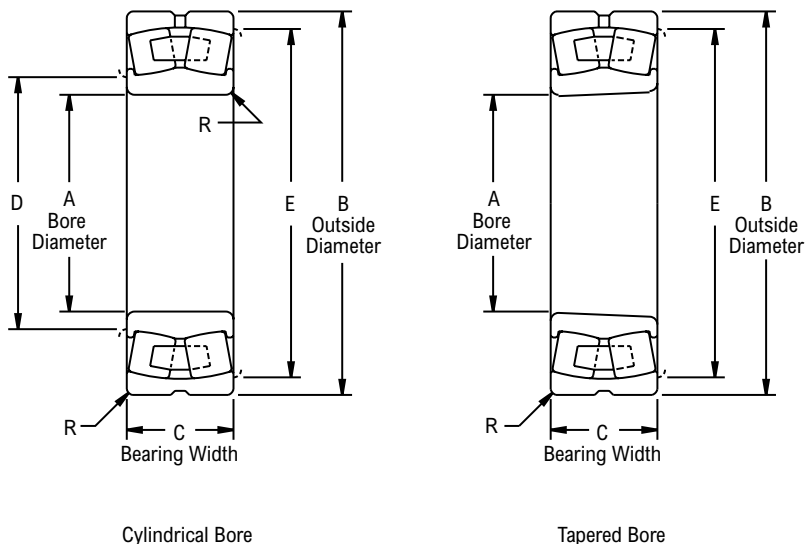


Tapered Bore

Bearing Dimensions

Cylindrical Part Number	Tapered Part Number	A Bore Diameter	B Outside Diameter	C Bearing Width	D	E	R	Approx. Weight
22308LBC3	22308LBKC3	1.5748 40.00	3.5433 90.00	1.2992 33.00	1.90 48	3.20 81	0.059 1.50	2.80
22309LBC3	22309LBKC3	1.7717 45.00	3.9370 100.00	1.4173 36.00	2.20 56	3.60 91	0.059 1.50	3.10
22310LBC3	22310LBKC3	1.9685 50.00	4.3307 110.00	1.5748 40.00	2.40 61	3.90 99	0.079 2.00	4.00
22311LBC3	22311LBKC3	2.1654 55.00	4.7244 120.00	1.6929 43.00	2.60 66	4.30 109	0.079 2.00	5.20
22312LBC3	22312LBKC3	2.3622 60.00	5.1181 130.00	1.8110 46.00	2.90 74	4.60 117	0.079 2.00	6.60
22313LBC3	22313LBKC3	2.5591 65.00	5.5118 140.00	1.8898 48.00	3.10 79	5.00 127	0.079 2.00	7.90
22314LBC3	22314LBKC3	2.7559 70.00	5.9055 150.00	2.0079 51.00	3.30 84	5.40 137	0.079 2.00	9.80
22315LBC3	22315LBKC3	2.9528 75.00	6.2992 160.00	2.1654 55.00	3.50 89	5.80 147	0.079 2.00	11.90
22316LBC3	22316LBKC3	3.1496 80.00	6.6929 170.00	2.2835 58.00	3.70 94	6.20 157	0.079 2.00	14.10
22317LBC3	22317LBKC3	3.3465 85.00	7.0866 180.00	2.3622 60.00	3.90 99	6.50 165	0.098 2.50	16.30
22318LBC3	22318LBKC3	3.5433 90.00	7.4803 190.00	2.5197 64.00	4.10 104	6.90 175	0.098 2.50	19.50
22319LBC3	22319LBKC3	3.7402 95.00	7.8740 200.00	2.6378 67.00	4.30 114	7.30 185	0.098 2.50	22.60
22320LBC3	22320LBKC3	3.9370 100.00	8.4646 215.00	2.8740 73.00	4.50 124	7.90 201	0.098 2.50	28.90
22322LBC3	22322LBKC3	4.3307 110.00	9.4488 240.00	3.1496 80.00	4.90 135	8.90 226	0.098 2.50	40.00
22324LBC3	22324LBKC3	4.7244 120.00	10.2362 260.00	3.3858 86.00	5.30 150	9.70 246	0.098 2.50	49.00
22326LBC3	22326LBKC3	5.1181 130.00	11.0236 280.00	3.6614 93.00	5.90 150	10.30 262	0.118 3.00	62.50
22328LBC3	22328LBKC3	5.5118 140.00	11.8110 300.00	4.0157 102.00	6.30 160	11.10 282	0.118 3.00	78.20

Continued...



Continued...

Bearing Dimensions

Cylindrical	Tapered	A Bore Diameter	B Outside Diameter	C Bearing Width	D	E	R	Approx. Weight
Part Number	Part Number							
22330LBC3	22330LBKC3	5.9055	12.5984	4.2520	6.60	11.90	0.118	92.00
		<i>150.00</i>	<i>320.00</i>	<i>108.00</i>	<i>168</i>	<i>302</i>	<i>3.00</i>	
22332LBC3	22332LBKC3	6.2992	13.3858	4.4882	7.10	12.70	0.118	110.00
		<i>160.00</i>	<i>340.00</i>	<i>114.00</i>	<i>180</i>	<i>323</i>	<i>3.00</i>	
22334LBC3	22334LBKC3	6.6929	14.1732	4.7244	7.40	13.50	0.118	129.00
		<i>170.00</i>	<i>360.00</i>	<i>120.00</i>	<i>188</i>	<i>343</i>	<i>3.00</i>	
22336LBC3	22336LBKC3	7.0866	14.9606	4.9606	7.80	14.30	0.118	153.00
		<i>180.00</i>	<i>380.00</i>	<i>126.00</i>	<i>198</i>	<i>363</i>	<i>3.00</i>	
22338LBC3	22338LBKC3	7.4803	15.7480	5.1968	8.40	14.90	0.157	176.00
		<i>190.00</i>	<i>400.00</i>	<i>132.00</i>	<i>213</i>	<i>378</i>	<i>4.00</i>	
22340LBC3	22340LBKC3	7.8740	16.5354	5.4331	8.80	15.70	0.157	200.00
		<i>200.00</i>	<i>420.00</i>	<i>138.00</i>	<i>224</i>	<i>399</i>	<i>4.00</i>	
22344LBC3	22344LBKC3	8.6614	18.1102	5.7087	9.60	17.30	0.157	287.00
		<i>220.00</i>	<i>460.00</i>	<i>145.00</i>	<i>244</i>	<i>439</i>	<i>4.00</i>	
22348LBC3	22348LBKC3	9.4488	19.6850	6.1024	10.70	18.40	0.197	321.90
		<i>240.00</i>	<i>500.00</i>	<i>155.00</i>	<i>272</i>	<i>467</i>	<i>5.00</i>	
22356LBC3	22356LBKC3	11.0236	22.8346	6.8898	12.60	21.30	0.236	482.80
		<i>280.00</i>	<i>580.00</i>	<i>175.00</i>	<i>320</i>	<i>541</i>	<i>6.00</i>	

Additional Notes

Please call 1-866-REXNORD for availability

Tapered bore, 1:12 on diameter

Dimension "R" is the largest fillet radius that will clear bearing corners

For the Selection Guide Load Ratings and Speed Limits, see the Link-Belt Spherical Roller Bearings Engineering section on pages 258 - 273.

For shaft bearing seat diameters, see Link-Belt Spherical Roller Bearings Shaft & Housing Seat Diameters section on pages 266 - 269.

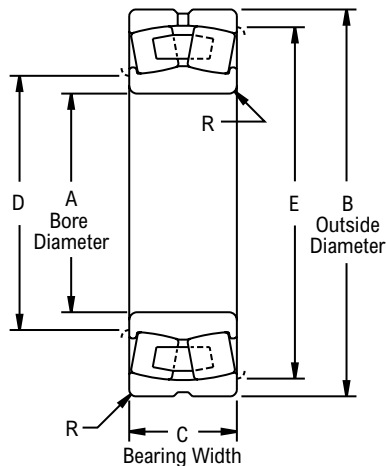
Note: Dimensions subject to change. Certified dimensions of ordered material furnished on request.

23000LB, 23000LBK

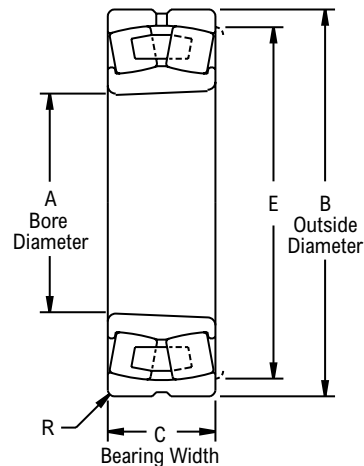


Product Features

- Cylindrical or Tapered bore
- Roller riding retainers
- Self-aligning
- Extra high capacity
- See Features and Benefits for additional info on page 256.



Cylindrical Bore



Tapered Bore

Bearing Dimensions

Cylindrical Part Number	Tapered Part Number	A Bore Diameter	B Outside Diameter	C Bearing Width	D	E	R	Approx. Weight
23044LBC3	23044LBK3	8.6614 <i>220.00</i>	13.3858 <i>340.00</i>	3.5433 <i>90.00</i>	9.60 <i>244</i>	12.60 <i>320</i>	0.118 <i>3.00</i>	64.80
23048LBC3	23048LBK3	9.4488 <i>240.00</i>	14.1732 <i>360.00</i>	3.6220 <i>92.00</i>	10.00 <i>254</i>	13.60 <i>345</i>	0.098 <i>2.50</i>	74.60
23052LBC3	23052LBK3	10.2362 <i>260.00</i>	15.7480 <i>400.00</i>	4.0945 <i>104.00</i>	11.40 <i>290</i>	14.70 <i>373</i>	0.157 <i>4.00</i>	101.90
23056LBC3	23056LBK3	11.0236 <i>280.00</i>	16.5354 <i>420.00</i>	4.1732 <i>106.00</i>	11.80 <i>300</i>	15.80 <i>401</i>	0.118 <i>3.00</i>	117.60
23060LBC3	23060LBK3	11.8110 <i>300.00</i>	18.1102 <i>460.00</i>	4.6457 <i>118.00</i>	13.00 <i>330</i>	17.00 <i>432</i>	0.118 <i>3.00</i>	163.30
23064LBC3	23064LBK3	12.5984 <i>320.00</i>	18.8976 <i>480.00</i>	4.7638 <i>121.00</i>	13.90 <i>353</i>	16.40 <i>417</i>	0.157 <i>4.00</i>	165.10
23068LBC3	23068LBK3	13.3858 <i>340.00</i>	20.4724 <i>520.00</i>	5.2362 <i>133.00</i>	14.80 <i>376</i>	19.20 <i>488</i>	0.197 <i>5.00</i>	220.50
23072LBC3	23072LBK3	14.1732 <i>360.00</i>	21.2598 <i>540.00</i>	5.2756 <i>134.00</i>	15.70 <i>399</i>	20.00 <i>508</i>	0.197 <i>5.00</i>	231.50
23076LBC3	23076LBK3	14.9606 <i>380.00</i>	22.0472 <i>560.00</i>	5.3150 <i>135.00</i>	16.50 <i>419</i>	20.80 <i>528</i>	0.197 <i>5.00</i>	246.90
23080LBC3	23080LBK3	15.7480 <i>400.00</i>	23.6220 <i>600.00</i>	5.8268 <i>148.00</i>	17.30 <i>439</i>	22.30 <i>566</i>	0.197 <i>5.00</i>	319.70
23084LBC3	23084LBK3	16.5354 <i>420.00</i>	24.4094 <i>620.00</i>	5.9055 <i>150.00</i>	18.10 <i>460</i>	23.10 <i>587</i>	0.197 <i>5.00</i>	330.70
23088LBC3	23088LBK3	17.3228 <i>440.00</i>	25.5906 <i>650.00</i>	6.1811 <i>157.00</i>	19.20 <i>488</i>	24.00 <i>610</i>	0.236 <i>6.00</i>	378.40
23092LBC3	23092LBK3	18.1102 <i>460.00</i>	26.7717 <i>680.00</i>	6.4173 <i>163.00</i>	20.00 <i>508</i>	25.10 <i>638</i>	0.236 <i>6.00</i>	438.70
23096LBC3	23096LBK3	18.8976 <i>480.00</i>	27.5591 <i>700.00</i>	6.4961 <i>165.00</i>	20.80 <i>528</i>	25.90 <i>658</i>	0.236 <i>6.00</i>	463.00
230530LBC3	230530LBK3	20.8661 <i>530.00</i>	30.7087 <i>780.00</i>	7.2835 <i>185.00</i>	22.90 <i>582</i>	29.00 <i>737</i>	0.236 <i>6.00</i>	651.20
230560LBC3	230560LBK3	22.0472 <i>560.00</i>	32.2835 <i>820.00</i>	7.6772 <i>195.00</i>	24.10 <i>612</i>	30.60 <i>777</i>	0.236 <i>6.00</i>	756.80
230600LBC3	230600LBK3	23.6220 <i>600.00</i>	34.2520 <i>870.00</i>	7.8740 <i>200.00</i>	25.80 <i>655</i>	32.50 <i>826</i>	0.236 <i>6.00</i>	855.80
230630LBC3	230630LBK3	24.8031 <i>630.00</i>	36.2205 <i>920.00</i>	8.3465 <i>212.00</i>	27.30 <i>693</i>	34.10 <i>866</i>	0.315 <i>8.00</i>	1,029.60

Additional Notes

- Please call 1-866-REXNORD for availability
- Tapered bore, 1:12 on diameter
- Dimension "R" is the largest fillet radius that will clear bearing corners
- For the Selection Guide Load Ratings and Speed Limits, see the Link-Belt Spherical Roller Bearings Engineering section on pages 258 - 273.

For shaft bearing seat diameters, see Link-Belt Spherical Roller Bearings Shaft & Housing Seat Diameters section on pages 266 - 269.

Note: Dimensions subject to change. Certified dimensions of ordered material furnished on request.

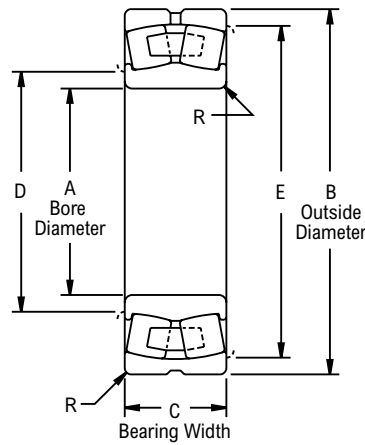
23100LB, 23100LBK



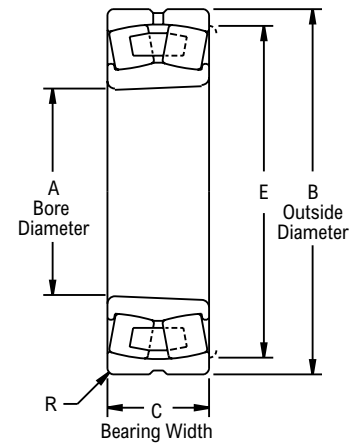
Photo Shows an Unmounted Spherical Roller Bearing Unit

Product Features

- Cylindrical or Tapered bore
- Roller riding retainers
- Self-aligning
- High Capacity
- See Features and Benefits for additional info on page 256.



Cylindrical Bore



Tapered Bore

Bearing Dimensions

Cylindrical Part Number	Tapered Part Number	A Bore Diameter	B Outside Diameter	C Bearing Width	D	E	R	Approx. Weight
23144LBC3	23144LBK3	8.6614 <i>220.00</i>	14.5669 <i>370.00</i>	4.7244 <i>120.00</i>	9.80 <i>249</i>	13.50 <i>343</i>	0.157 <i>4.00</i>	116.00
23148LBC3	23148LBK3	9.4488 <i>240.00</i>	15.7480 <i>400.00</i>	5.0394 <i>128.00</i>	10.60 <i>269</i>	14.70 <i>373</i>	0.157 <i>4.00</i>	142.00
23152LBC3	23152LBK3	10.2362 <i>260.00</i>	17.3228 <i>440.00</i>	5.6693 <i>144.00</i>	11.40 <i>290</i>	16.30 <i>414</i>	0.157 <i>4.00</i>	193.10
23156LBC3	23156LBK3	11.0236 <i>280.00</i>	18.1102 <i>460.00</i>	5.7480 <i>146.00</i>	12.40 <i>315</i>	16.90 <i>429</i>	0.197 <i>5.00</i>	206.30
23160LBC3	23160LBK3	11.8110 <i>300.00</i>	19.6850 <i>500.00</i>	6.2992 <i>160.00</i>	13.20 <i>335</i>	18.40 <i>467</i>	0.197 <i>5.00</i>	273.40
23164LBC3	23164LBK3	12.5984 <i>320.00</i>	21.2598 <i>540.00</i>	6.9291 <i>176.00</i>	14.00 <i>356</i>	20.00 <i>508</i>	0.197 <i>5.00</i>	354.90
23168LBC3	23168LBK3	13.3858 <i>340.00</i>	22.8346 <i>580.00</i>	7.4803 <i>190.00</i>	14.80 <i>376</i>	21.50 <i>546</i>	0.197 <i>5.00</i>	451.90
23172LBC3	23172LBK3	14.1732 <i>360.00</i>	23.6220 <i>600.00</i>	7.5591 <i>192.00</i>	15.70 <i>399</i>	20.00 <i>508</i>	0.197 <i>5.00</i>	474.00
23176LBC3	23176LBK3	14.9606 <i>380.00</i>	24.4094 <i>620.00</i>	7.6378 <i>194.00</i>	16.50 <i>419</i>	23.10 <i>587</i>	0.197 <i>5.00</i>	500.40
23180LBC3	23180LBK3	15.7480 <i>400.00</i>	25.5905 <i>650.00</i>	7.8740 <i>200.00</i>	17.60 <i>447</i>	24.00 <i>610</i>	0.236 <i>6.00</i>	564.40
23184LBC3	23184LBK3	16.5354 <i>420.00</i>	27.5591 <i>700.00</i>	8.8189 <i>224.00</i>	18.30 <i>465</i>	25.90 <i>658</i>	0.236 <i>6.00</i>	745.10
23188LBC3	23188LBK3	17.3228 <i>440.00</i>	28.3465 <i>720.00</i>	8.8976 <i>226.00</i>	19.20 <i>488</i>	26.70 <i>678</i>	0.236 <i>6.00</i>	789.20
23192LBC3	23192LBK3	18.1102 <i>460.00</i>	29.9213 <i>760.00</i>	9.4488 <i>240.00</i>	20.30 <i>516</i>	27.90 <i>709</i>	0.315 <i>8.00</i>	925.90
23196LBC3	23196LBK3	18.8976 <i>480.00</i>	31.1024 <i>790.00</i>	9.7638 <i>248.00</i>	21.10 <i>536</i>	29.10 <i>739</i>	0.315 <i>8.00</i>	1,040.60
231530LBC3	231530LBK3	20.8661 <i>530.00</i>	34.2520 <i>870.00</i>	10.7087 <i>272.00</i>	23.20 <i>589</i>	32.20 <i>818</i>	0.315 <i>8.00</i>	1,381.60
231560LBC3	231560LBK3	22.0472 <i>560.00</i>	36.2205 <i>920.00</i>	11.0236 <i>280.00</i>	24.40 <i>620</i>	34.10 <i>866</i>	0.315 <i>8.00</i>	1,599.40
231600LBC3	231600LBK3	23.6220 <i>600.00</i>	38.5827 <i>980.00</i>	11.8110 <i>300.00</i>	26.10 <i>663</i>	36.40 <i>925</i>	0.315 <i>8.00</i>	1,975.60
231630LBC3	231630LBK3	24.8031 <i>630.00</i>	40.5512 <i>1,030.00</i>	12.4016 <i>315.00</i>	27.30 <i>693</i>	38.30 <i>973</i>	0.315 <i>8.00</i>	2,288.00

Additional Notes

Please call 1-866-REXNORD for availability
 Tapered bore, 1:12 on diameter
 Dimension "R" is the largest fillet radius that will clear bearing corners
 For the Selection Guide Load Ratings and Speed Limits, see the Link-Belt Spherical Roller Bearings Engineering section on pages 258 - 273.

For shaft bearing seat diameters, see Link-Belt Spherical Roller Bearings Shaft & Housing Seat Diameters section on pages 266 - 269.

Note: Dimensions subject to change. Certified dimensions of ordered material furnished on request.

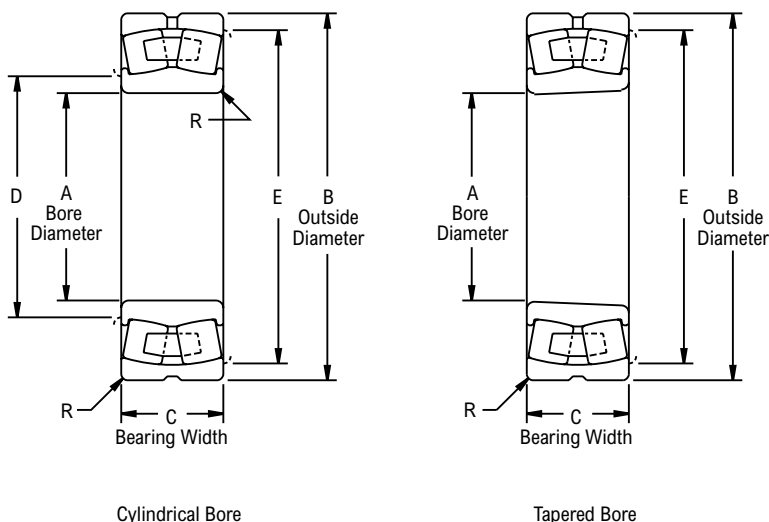
23200LB, 23200LBK



Photo Shows an Unmounted Spherical Roller Bearing Unit

Product Features

- Cylindrical or Tapered bore
- Roller riding retainers
- Self-aligning
- High Capacity
- See Features and Benefits for additional info on page 256.



Bearing Dimensions

Cylindrical	Tapered	A	B	C	D	E	R	Approx. Weight
Part Number	Part Number	Bore Diameter	Outside Diameter	Bearing Width				
23244LBC3	23244LBK3	8.6614 <i>220.00</i>	15.7480 <i>400.00</i>	5.6693 <i>144.00</i>	9.80 <i>249</i>	14.70 <i>373</i>	0.157 <i>4.00</i>	175.70
23248LBC3	23248LBK3	9.4488 <i>240.00</i>	17.3228 <i>440.00</i>	6.2992 <i>160.00</i>	10.60 <i>269</i>	16.30 <i>414</i>	0.157 <i>4.00</i>	231.50
23252LBC3	23252LBK3	10.2362 <i>260.00</i>	18.8976 <i>480.00</i>	6.8504 <i>174.00</i>	11.60 <i>295</i>	17.60 <i>447</i>	0.197 <i>5.00</i>	297.60
23256LBC3	23256LBK3	11.0236 <i>280.00</i>	19.6850 <i>500.00</i>	6.9291 <i>176.00</i>	12.40 <i>315</i>	18.40 <i>467</i>	0.197 <i>5.00</i>	319.70
23260LBC3	23260LBK3	11.8110 <i>300.00</i>	21.2598 <i>540.00</i>	7.5591 <i>192.00</i>	13.20 <i>335</i>	20.00 <i>508</i>	0.197 <i>5.00</i>	414.50
23264LBC3	23264LBK3	12.5984 <i>320.00</i>	22.8346 <i>580.00</i>	8.1890 <i>208.00</i>	14.00 <i>356</i>	21.50 <i>546</i>	0.197 <i>5.00</i>	522.50
23268LBC3	23268LBK3	13.3858 <i>340.00</i>	24.4094 <i>620.00</i>	8.8189 <i>224.00</i>	15.10 <i>384</i>	22.80 <i>579</i>	0.236 <i>6.00</i>	643.70
23272LBC3	23272LBK3	14.1732 <i>360.00</i>	25.5905 <i>650.00</i>	9.1339 <i>232.00</i>	15.90 <i>404</i>	24.00 <i>610</i>	0.236 <i>6.00</i>	727.50
23276LBC3	23276LBK3	14.9606 <i>380.00</i>	26.7717 <i>680.00</i>	9.4488 <i>240.00</i>	16.70 <i>424</i>	25.10 <i>638</i>	0.236 <i>6.00</i>	813.50
23280LBC3	23280LBK3	15.7480 <i>400.00</i>	28.3465 <i>720.00</i>	10.0787 <i>256.00</i>	17.60 <i>447</i>	26.70 <i>678</i>	0.236 <i>6.00</i>	983.20
23284LBC3	23284LBK3	16.5354 <i>420.00</i>	29.9213 <i>760.00</i>	10.7087 <i>272.00</i>	18.70 <i>475</i>	27.90 <i>709</i>	0.315 <i>8.00</i>	1,170.60
23288LBC3	23288LBK3	17.3228 <i>440.00</i>	31.1024 <i>790.00</i>	11.0236 <i>280.00</i>	19.50 <i>495</i>	29.10 <i>739</i>	0.315 <i>8.00</i>	1,298.50
23292LBC3	23292LBK3	18.1102 <i>460.00</i>	32.6772 <i>830.00</i>	11.6535 <i>296.00</i>	20.30 <i>516</i>	30.60 <i>777</i>	0.315 <i>8.00</i>	1,511.40
23296LBC3	23296LBK3	18.8976 <i>480.00</i>	34.2520 <i>870.00</i>	12.2047 <i>310.00</i>	21.10 <i>536</i>	32.20 <i>818</i>	0.315 <i>8.00</i>	1,742.40

Additional Notes

- Please call 1-866-REXNORD for availability
- Tapered bore, 1:12 on diameter
- Dimension "R" is the largest fillet radius that will clear bearing corners
- For the Selection Guide Load Ratings and Speed Limits, see the Link-Belt Spherical Roller Bearings Engineering section on pages 258 - 273.
- For shaft bearing seat diameters, see Link-Belt Spherical Roller Bearings Shaft & Housing Seat Diameters section on pages 266 - 269.
- Note: Dimensions subject to change. Certified dimensions of ordered material furnished on request.

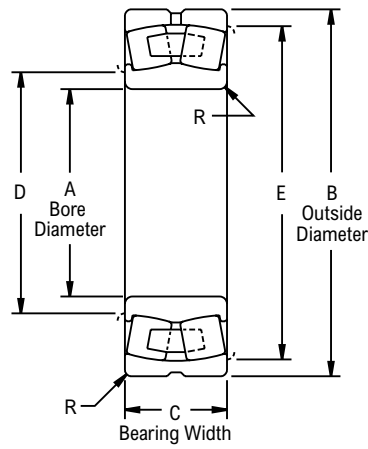
23900LB, 23900LBK



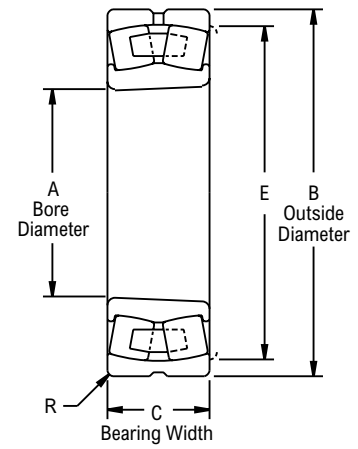
Photo Shows an Unmounted Spherical Roller Bearing Unit

Product Features

- Cylindrical or Tapered bore
- Roller riding retainers
- Self-aligning
- High Capacity
- See Features and Benefits for additional info on page 256.



Cylindrical Bore



Tapered Bore

Bearing Dimensions

Cylindrical Part Number	Tapered Part Number	A Bore Diameter	B Outside Diameter	C Bearing Width	D	E	R	Approx. Weight
23944LBC3	23944LBKC3	8.6614 <i>220.00</i>	11.8110 <i>300.00</i>	2.3622 <i>60.00</i>	9.50 <i>241</i>	11.10 <i>282</i>	0.079 <i>2.00</i>	26.70
23948LBC3	23948LBKC3	9.4488 <i>240.00</i>	12.5984 <i>320.00</i>	2.3622 <i>60.00</i>	10.40 <i>264</i>	11.90 <i>302</i>	0.079 <i>2.00</i>	28.90

Additional Notes

- Please call 1-866-REXNORD for availability
- Tapered bore, 1:12 on diameter
- Dimension "R" is the largest fillet radius that will clear bearing corners
- For the Selection Guide Load Ratings and Speed Limits, see the Link-Belt Spherical Roller Bearings Engineering section on pages 258 - 273.
- For shaft bearing seat diameters, see Link-Belt Spherical Roller Bearings Shaft & Housing Seat Diameters section on pages 266 - 269.
- Note: Dimensions subject to change. Certified dimensions of ordered material furnished on request.

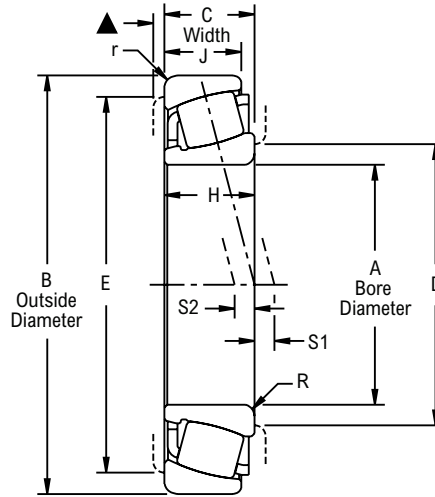
A20000S



Photo Shows an Unmounted Spherical Roller Bearing Unit

Product Features

- Single row
- Adjustable
- Self aligning
- Deep coined retainer
- Double contoured roller pocket
- See Features and Benefits for additional info on page 256.



Bearing Dimensions

Part Number	A Bore Diameter	B Outside Diameter	C Bearing Width	D	E	H	J	R	r	S1 & S2	Approx. Weight
A22100S	1.0000	2.3750	0.7810	1.37	2.00	0.7930	0.4910	0.046	0.046	0.187	1.00
A22150S	1.5000	2.8345	0.6700	1.81	2.50	0.6500	0.5460	0.062	0.062	0.015	1.10
A22196S	1.9680	3.5433	0.7870	2.38	3.18	0.7870	0.6510	0.078	0.078	0.024	1.20
A23225S	2.2500	3.9370	0.8280	2.65	3.50	0.8600	0.6930	0.093	0.062	0.000	4.00
A22262S	2.6250	4.4677	0.9480	3.06	4.07	1.0000	0.6900	0.140	0.062	0.090	2.00
A22300S	3.0000	5.1172	1.0620	3.40	4.57	1.0620	0.9280	0.078	0.078	0.000	2.40
A23300S	3.0000	5.9045	1.1090	4.00	5.34	1.2360	0.9250	0.140	0.125	0.048	5.00
A23334S	3.3457	5.9045	1.1090	4.00	5.34	1.1090	0.9250	0.125	0.125	0.048	5.10

Additional Notes

Please call 1-866-REXNORD for availability

▲ Housing recess: recommended 3/16 in, minimum 1/16 in

Dimension "R" & "r" are the largest fillet radius that will clear bearing corners

Bearing O.D. tolerance, +.001 in/-.000 in (+0.025 mm/-0.000 mm)

Bore tolerance for shaft sizes 3.0000 in and smaller, +.0005 in/-.0000 in (+0.013 mm/-0.000 mm); for all other shaft sizes, +.0010 in/-.0000 in (+0.025 mm/-0.000 mm)

"S1" dimension applies to bore diameters 3.000 in to 4.1331 in, "S2" dimension for all others

For the Selection Guide Load Ratings and Speed Limits, see the Link-Belt Spherical Roller Bearings Engineering section on pages 258 - 273.

For shaft bearing seat diameters, see Link-Belt Spherical Roller Bearings Shaft & Housing Seat Diameters section on pages 266 - 269.

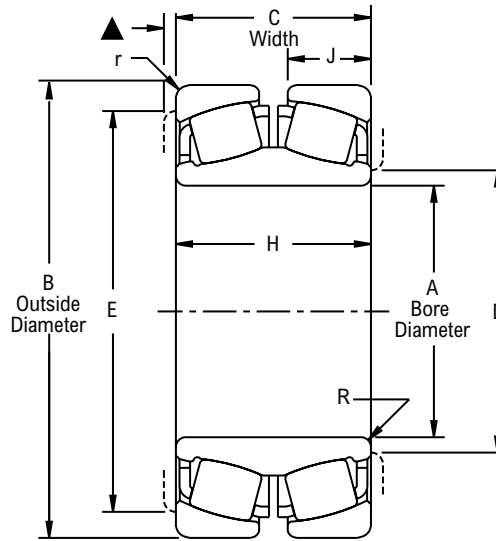
Note: Dimensions subject to change. Certified dimensions of ordered material furnished on request.



Photo Shows an Unmounted Spherical Roller Bearing Unit

Product Features

- Double row
- Adjustable
- Self aligning
- Deep coined retainers
- Double contoured roller pocket
- See Features and Benefits for additional info on page 256.



Bearing Dimensions

Part Number	A Bore Diameter	B Outside Diameter	C Bearing Width	D	E	H	J	R	r	Approx. Weight
A22100	1.0000	2.3750	1.1880	1.31	2.00	1.1880	0.4910	0.046	0.046	1.20
A22112	1.1250	2.3750	1.1880	1.31	2.00	1.1880	0.4910	0.046	0.046	1.20
A22118	1.1875	2.6250	1.3120	1.50	2.31	1.3120	0.5410	0.046	0.062	1.20
A22125	1.2500	2.6250	1.3120	1.50	2.31	1.3120	0.5410	0.046	0.062	1.20
A22137	1.3775	2.8345	1.3100	1.68	2.50	1.3100	0.5460	0.046	0.062	1.60
A22150	1.5000	2.8345	1.3100	1.68	2.50	1.3100	0.5460	0.046	0.062	1.60
A22177	1.7712	3.3464	1.5780	2.00	2.87	1.5780	0.6510	0.080	0.062	1.60
A22196	1.9680	3.5433	1.5260	2.25	3.18	1.5260	0.6510	0.062	0.078	2.30
A23196	1.9680	3.9370	1.6560	2.25	3.50	1.6560	0.6240	0.093	0.062	2.30
A24196	1.9680	4.3299	2.0620	2.18	3.83	2.0620	0.8360	0.062	0.080	4.00
A23200	2.0000	3.9370	1.6560	2.50	3.50	1.6560	0.6930	0.093	0.062	4.00
A23225	2.2500	3.9370	1.6560	2.50	3.50	1.6560	0.6930	0.093	0.062	4.00
A24236	2.3616	4.3307	1.7500	2.68	3.87	1.7500	0.7630	0.062	0.078	4.00
A22262	2.6250	4.4677	1.7160	3.00	4.07	1.7160	0.6900	0.140	0.062	6.60
A23262	2.6250	5.0000	2.1880	2.90	4.44	2.1880	0.9360	0.078	0.078	6.60
A22275	2.7500	5.1172	2.1250	3.31	4.57	2.1500	0.9280	0.080	0.078	6.90
A22295	2.9522	5.1172	2.1250	3.31	4.57	2.1500	0.9280	0.140	0.078	6.90
A23334	3.3457	5.9045	2.3130	3.75	5.34	2.3130	0.9250	0.078	0.125	6.90
A22343	3.4375	6.0000	2.7500	4.00	5.43	2.7500	1.1730	0.078	0.125	11.30
A22351	3.5100	6.0000	2.7500	4.00	5.43	2.7500	1.1730	0.078	0.125	11.30
A22362	3.6250	6.0000	2.7500	4.00	5.43	2.7500	1.1730	0.078	0.125	11.30
A24374	3.7402	7.0866	2.6770	4.19	6.38	2.6770	1.1520	0.093	0.125	11.30

Additional Notes

- Please call 1-866-REXNORD for availability
- ▲ Housing recess: recommended 3/16 in, minimum 1/16 in
- Dimension "R" & "r" are the largest fillet radius that will clear bearing corners
- Bearing O.D. tolerance, +.001 in/-.000 in (**+0.025 mm/-0.000 mm**)
- Bore tolerance for shaft sizes 2.5000 in and smaller, +.0005 in/-.0000 in (**+0.013 mm/-0.000 mm**); for all other shaft sizes, +.0010 in/-.0000 in (**+0.025 mm/-0.000 mm**)
- Bearing width tolerance, +/- .025 in (**+/-0.64 mm**)
- Housing must allow clearance for this adjustment on dimension "C"

For the Selection Guide Load Ratings and Speed Limits, see the Link-Belt Spherical Roller Bearings Engineering section on pages 258 - 273.

For shaft bearing seat diameters, see Link-Belt Spherical Roller Bearings Shaft & Housing Seat Diameters section on pages 266 - 269.

Note: Dimensions subject to change. Certified dimensions of ordered material furnished on request.

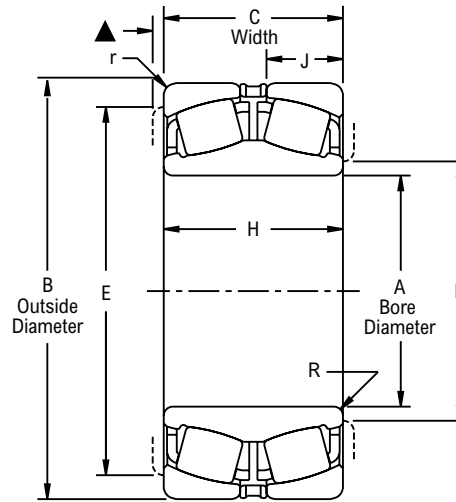
A20000M



Photo Shows an Unmounted Spherical Roller Bearing Unit

Product Features

- Double row
- Factory adjusted
- Self aligning
- Deep coined retainers
- Double contoured roller pocket
- See Features and Benefits for additional info on page 256.



Bearing Dimensions

Part Number	A Bore Diameter	B Outside Diameter	C Bearing Width	D	E	H	J	R	r	Approx. Weight
A22100M	1.0000	2.3750	1.1880	1.31	2.00	1.1880	0.4910	0.046	0.046	1.00
A22112M	1.1250	2.3750	1.1880	1.31	2.00	1.1880	0.4910	0.046	0.046	1.00
A22118M	1.1875	2.6250	1.3120	1.50	2.31	1.3120	0.5410	0.046	0.062	1.00
A22125M	1.2500	2.6250	1.3120	1.50	2.31	1.3120	0.5410	0.046	0.062	1.00
A22137M	1.3775	2.8345	1.3100	1.68	2.50	1.3100	0.5460	0.046	0.062	1.70
A22150M	1.5000	2.8345	1.3100	1.68	2.50	1.3100	0.5460	0.046	0.062	1.70
A22177M	1.7712	3.3464	1.5780	2.00	2.87	1.5780	0.6510	0.080	0.062	1.70
A22196M	1.9680	3.5433	1.5260	2.25	3.18	1.5260	0.6510	0.062	0.078	2.40
A23196M	1.9680	3.9370	1.6560	2.25	3.50	1.6560	0.6240	0.093	0.062	2.40
A23200M	2.0000	3.9370	1.6560	2.50	3.50	1.6560	0.6930	0.093	0.062	4.00
A23225M	2.2500	3.9370	1.6560	2.50	3.50	1.6560	0.6930	0.093	0.062	4.00
A24196M	1.9680	4.3299	2.0620	2.18	3.83	2.0620	0.8360	0.062	0.080	4.00
A24236M	2.3616	4.3307	1.7500	2.68	3.87	1.7500	0.7630	0.062	0.078	4.00
A23262M	2.6250	5.0000	2.1880	2.90	4.44	2.1880	0.9360	0.078	0.078	6.70
A22275M	2.7500	5.1172	2.1250	3.31	4.57	2.1500	0.9280	0.080	0.078	9.50
A22295M	2.9522	5.1172	2.1250	3.31	4.57	2.1500	0.9280	0.140	0.078	9.50
A23334M	3.3457	5.9045	2.3130	3.75	5.34	2.3130	0.9250	0.078	0.125	9.50
A22343M	3.4375	6.0000	2.7500	4.00	5.43	2.7500	1.1730	0.078	0.125	15.00
A22351M	3.5100	6.0000	2.7500	4.00	5.43	2.7500	1.1730	0.078	0.125	15.00
A22362M	3.6250	6.0000	2.7500	4.00	5.43	2.7500	1.1730	0.078	0.125	15.00

Additional Notes

Please call 1-866-REXNORD for availability

Complete part number includes clearance symbol, i.e. A22100MCO

▲ Housing recess: recommended 3/16 in, minimum 1/16 in

Dimension "R" & "r" are the largest fillet radius that will clear bearing corners

Bearing O.D. tolerance, +.001 in/-.000 in (+0.025 mm/-0.000 mm)

Bore tolerance for shaft sizes 2.5000 in and smaller, +.0005 in/-.0000 in (+0.013 mm/-0.000 mm); for all other shaft sizes, +.0010 in/-.0000 in (+0.025 mm/-0.000 mm)

Bearing width tolerance, +/- .025 in (+/-0.64 mm)

Housing must allow clearance for this adjustment on dimension "C"

For the Selection Guide Load Ratings and Speed Limits, see the Link-Belt Spherical Roller Bearings Engineering section on pages 258 - 273.

For shaft bearing seat diameters, see Link-Belt Spherical Roller Bearings Shaft & Housing Seat Diameters section on pages 266 - 269.

Note: Dimensions subject to change. Certified dimensions of ordered material furnished on request.

Ball Bearings Standard Duty (200 Series) Units: Link-Belt



Contents

	Page
Features and Benefits	286
Nomenclature	288
Engineering	290
Dimensions	
Pillow Blocks	299
Flange Blocks	321
Take-up Blocks	359
Hanger Units	366
Take-up Assemblies	369
Take-up Frames	373
Hanger and Trough Units	377
Unmounted Replacement Bearings	379

Industries Served

Aggregates
Agriculture
Air Handling
Package Handling
Construction
Shipping



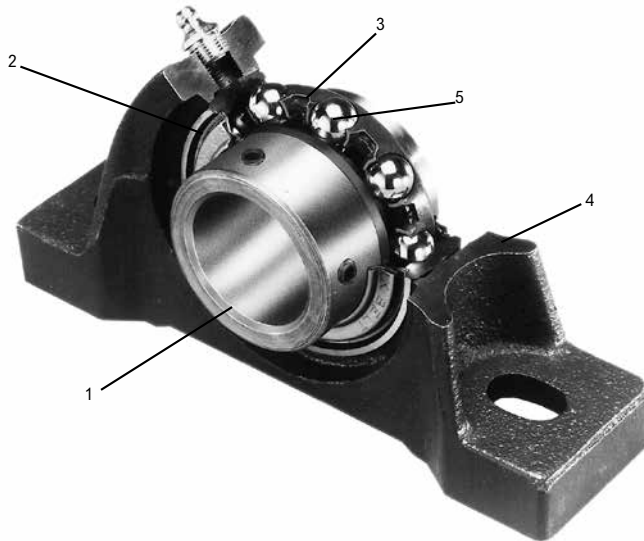
200 Series Standard & Intermediate Duty Ball Bearings

200 Series standard and intermediate duty ball bearing units provide a versatility of application arrangements for carrying shafts with radial or combination radial and thrust loads. They are designed for general purpose industrial machinery, conveyors, chain and belt drives, fans and blowers, power transmission and many other applications.

Collar Mounted Ball Bearings

Series CL200, U200, S200, W200, Y200 collar mounted or spring locking ball bearings, and round, square and hex bore ball bearings provide economic and versatile arrangements for supporting shafts, especially with the 2-piece formed steel flanged housings.

These product lines are designed for light industrial applications, agricultural machinery, lawn and garden equipment, recreational vehicles and other applications.



1. Inner Ring

Extended or wide inner ring for moderate or high stability and load support.

2. Choice of Locking Device

Choice of Centrik-Lok locking device, eccentric cam locking collar or spring locking or spring locking collar with set screws to lock inner ring securely to shaft.

3. Choice of Seal Type

Choice of steel-clad type H labyrinth seal, type N single lip seal or type E3 triple lip seal. W200 & S200 series have the type E single lip seal only available.

4. One-piece Housing

Compact one-piece housing provides excellent mounting support.

5. Precision Ball Bearing

Alignable precision deep groove ball bearing manufactured of quality alloy bearing steel provides high capacity and long life.

1. Precision Ball Bearing

Precision deep groove ball bearings or quality alloy bearing steel provide high capacity and long life.

2. Choice of Locking Device

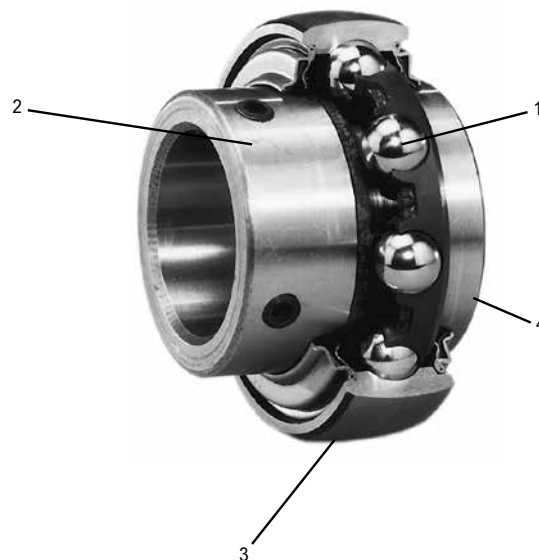
Choice of Centrik-Lok locking device, eccentric cam locking collar or spring locking or spring locking collar with set screws to lock inner ring securely to shaft.

3. Optional Features

Optional features such as spherical or cylindrical O.D.'s, relubricatable or non-relubricatable.

4. Inner Ring Options

Extended or wide inner rings to meet diverse application requirements.



Wide and Extended Inner Ring Ball Bearings

Centrik-Lok CL

Precision alignable ball bearings of deep groove construction for high capacity and high precision applications. Centrik-Lok device securely locks the bearing to the shaft. This method of locking provides excellent holding power and also centers the shaft in the bearing. It eliminates shaft damage because setscrews don't contact the shaft making bearing removal easier. The C200 wide inner ring furnishes increased shaft support and accommodates wider seals for extra lubricant capacity.



Spring Locking

Precision alignable ball bearings of deep groove construction for high capacity and high precision applications. Spring locking collar or setscrew locking securely locks the bearing to the shaft. The U200 wide inner ring furnishes increased shaft support and accommodates wider seals for extra lubricant capacity.



Eccentric Cam Locking Collars

Precision alignable ball bearings of deep groove construction. Eccentric cam locking collars hold the bearings securely to the shaft and further tightens with bearing rotation. The Y200 wide inner ring provides increased shaft support and accommodates wide seals for extra lubricant capacity.



One-piece Housings

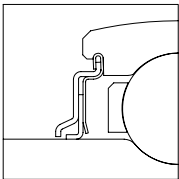
Rugged one-piece precision machined housings of many types provide a versatility of mounting arrangement and facilitate installation. All mounting surfaces are fully machined and all housings provide for easy bearing relubrication. Grease flows through the fitting into a machined grease groove and through the lubricant holes of the outer ring directly into the bearing chamber between the seals. Pillow blocks have slotted bolt holes with ample space provided for drilling dowel pin holes. Flanged units have drilled mounting holes. Take-up units have machined slots for accurate adjustment.

Steel Clad Seals

All bearing type seals are crimped tightly in the bearing outer rings with steel members and cannot be blown out during relubrication.

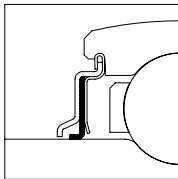
Type H Multi-labyrinth Seal

This seal has contoured external trash guard is an excellent all purpose low friction seal for grease lubrication.



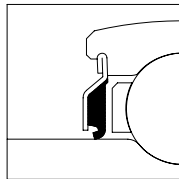
Type N Lip Seals

These seals have the same contoured external trash guard for maximum lip protection and a full land riding lip for grease retention and dirt exclusion. These seals ride on a precision ground surface of the bearing inner ring for smooth operation and tightness.



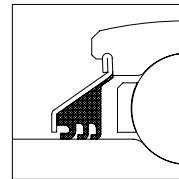
Type E Molded Lip Seal

The type E seal has external trash guard for maximum lip protection and a full land riding lip for grease retention and dirt exclusion.



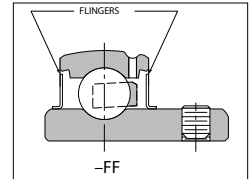
Type E3 Triple Lip Seal

This seal is a tight high torque seal for ultimate dirt exclusion. It has an external trash guard to protect the precision die molded lip members.



Type FF Flingers

This seal is for "free running" applications and/or temperatures over 400°F where contamination is not severe.



200 Series Nomenclature

Symbol	Description	PL	3	U	2	E	20	H	C	K75
F	Flanged unit, 3 and 4-bolt									
FB	Flanged bracket unit, 3-bolt									
FF	Flanged screw conveyor unit, 4-bolt									
FC	Flanged cartridge unit, 4-bolt round									
FX	Flanged unit, 2-bolt									
FR	Flanged unit, 3 and 4-bolt inboard mounting									
FXR	Flanged unit, 2-bolt inboard mounting									
HM	Hanger screw conveyor unit									
P	Pillow block, standard backing									
PH	Pillow block, high backing									
PL	Pillow block, low backing									
PS	Pillow block, formed steel housing									
PT	Pillow block, tapped base									
T	Take-up, standard slot									
TH	Take-up, wide slot									
TAS	Conveyor take-up, formed steel frame									
TDS	Conveyor take-up, hinged top, welded steel frame									
NT	Conveyor take-up, welded channel frame									
3	Integral bearing seals	_____								
CL	Wide inner ring, Centrik-Lok collar									
S	Narrow inner ring, spring locking									
U	Wide inner ring, spring locking									
Y	Wide inner ring, eccentric cam locking collar									
W	Narrow inner ring, eccentric cam locking collar									
None	Non-relubricatable bearing									
G	Relubricatable bearing									
2	200 Series ball bearing designation	_____								
B	Inner ring bore equal to a bore of preceding smaller bearing group									
E	Inner ring bore equal to a bore of following larger bearing group									
20	Shaft size in sixteenths of an inch									
M30	Shaft size, metric series in millimeters									
J	Steel retainers	_____								
E3	Triple lip seals									
E	Molded single lip seals									
FF	Flingers only, 50% grease fill									
HFF	Flingers only, 10% oil fill									
MHFF	Flingers only, 10% grease fill									
H	Floating labyrinth seals									
N	Single lip seals									
C	Closed end unit	_____								
K75	Nickel plated housing	_____								
18	Take-up adjustment, inches	_____								
K4	100% Grease Filled	_____								
K5	No Grease - Preservative only	_____								
K6	100% Grease filled and housing plugged	_____								
K13	Housing Plugged	_____								
K75	Nickel Plated Housing	_____								
K82	Black oxide coated rings	_____								
18A	SHC100 Grease	_____								
18W	SHC460 Grease	_____								
18Y	SHC220 Grease	_____								
4C	molykote 44 Grease	_____								
99A	Food Grade Grease	_____								
2, 3, 4, 5	Clearances other than standard	_____								

200 Series Collar Unmounted Ball Bearings Nomenclature

Symbol	Description	U	B	G	2	E	20	H	L
CL	Wide Inner Ring, Centrik-Lok Collar								
ER	Adapter series, cylindrical O.D. with lube groove and O.D. locating ring								
MSL	Ball bearing, cylindrical O.D., wide inner ring, spring locking								
MSLN	Ball bearing, cylindrical O.D., narrow inner ring, spring locking								
RER	Rubber cartridge unit (used in FPSR2 units)								
S	Extended inner ring, spring locking								
U	Wide inner ring, spring locking								
Y	Wide inner ring, eccentric cam locking collar								
W	Extended inner ring, eccentric cam locking collar								
None	O.D. of outer ring is spherical								
B	O.D. of outer ring is cylindrical								
None	Non-relubricatable bearing								
G	Relubricatable bearing								
2	200 Series ball bearing designation								
B	Inner ring bore equal to a bore of preceding smaller bearing group								
E	Inner ring bore equal to a bore of following larger bearing group								
20	Shaft size in sixteenths of an inch								
M30	Shaft size, metric series in millimeters								
E3	Triple lip seals								
E	Molded single lip seals								
H	Floating labyrinth seals								
N	Single lip seals								
L1	Bearing without collar								
L	Bearing with collar & setscrews								

Hex, Round and Square Bore Ball Bearings Nomenclature

Symbol	Description	31	R	B	G	3	-	2	10	J	E3
None	Bore is basic metric size										
31	Shaft size in sixteenths of an inch										
R	Bearing bore is round										
S	Bearing bore is square										
K	Bearing bore is hex										
None	O.D. of outer ring is spherical										
B	O.D. of outer ring is cylindrical										
None	Non-relubricatable										
G	Relubricatable (two holes in outer ring @ 180°)										
None	Metric width outer ring; basic inch width inner ring										
2	Basic inch width outer ring; intermediate inch width inner ring										
3	Basic inch width outer ring; basic inch width inner ring										
4	Basic inch width outer ring; unground spherical O.D. with flat ground cylindrical center; intermediate inch width inner ring										
5	Metric width outer ring; intermediate inch width inner ring										
6	Basic inch width outer ring; wide inch width inner ring										
7	Wide metric width outer ring; intermediate inch width inner ring										
8	Wide metric width outer ring; wide inch width inner ring										
2	Series 200 ball bearing designation										
E	Bore is .031 inch oversize										
10	One fifth of basic mm bore size										
None	Non-metallic retainer										
J	Formed steel retainer, two-piece										
N	Single lip seals										
E3	Triple lip seals										

Seal Selection Guide

The choice of the seal for a mounted bearing is often the key to successful bearing operation and long service life. The Seal Selection Guide incorporates years of experience against the wide variety of conditions encountered on actual applications. Following the simple selection procedure outlined can translate the benefits of that broad experience to the individual applications through the choice of the most effective seal.

How to Use the Selection Guide

- The appropriate seal for a given application may be selected by comparing the job application conditions against those listed in the Seal Rating Guide on this page.
- When more than one application condition is present, the most appropriate seal may be selected based on prime sealing for the most detrimental condition, and secondary consideration given to the other application conditions.
- If further evaluation of the seals must be made, then refer to the General Design and Characteristic Guide
- Addition of auxiliary caps will enhance the primary seal performance shown in the chart.

Considerations in Addition to Seal Selection

Under certain adverse conditions, other changes should be considered to achieve maximum bearing life:

- High temperature lubricants where housing or ambient temperatures exceed +200°F.
- Special greases for additional bearing protection where excessive water, solvents or chemicals are present.
- EP (extreme pressure) greases where high load, high shock load, or continuous vibration is present.
- Readjustment of internal operating clearance of bearing where extreme high or low temperature conditions exist.

Seal Rating Guide

Application Conditions	Seal Ratings			
	Clearance H	Single Lip E	Single Lip N	Triple Lip E3
Shaft Position				
Horizontal Shaft	4	4	4	4
Vertical Shaft	1	4	4	4
Operating Temperature				
Below -40°F	4	1	1	1
-40°F to 0°F	4	3	3	3
0°F to +250°F	4	4	4	4
+250°F to +400°F	4	0	0	0
Over 400°F	4	0	0	0
Speed				
Equal to / Less than limit below	4	4	4	4
More than limit below	4	1	1	1
Vibration/Shock				
Occasional - Mild	3	4	4	4
Occasional - Severe	2	4	4	4
Continuous - Mild	1	3	3	3
Continuous - Severe	0	3	3	3
Abrasive Material				
Coarse - Over #10 Mesh	4	4	4	4
Small - #10 to #50 Mesh	3	4	4	4
Fine - #50 to #200 Mesh	1	3	3	4
Very fine - Under #200 Mesh	0	3	3	4
"Caking or buildup" (cement, etc.)	2	3	3	4
Moisture				
Splash	2	4	4	4
Rain	2	4	4	4
Saturated Atmosphere	1	4	4	4
Flooding	0	3	3	4
Pressure Wash	0	3	3	4
Fibrous Material				
Short Fibers (lint, etc.)	1	3	3	4
Long Fibers (grass, etc.)	1	3	3	4
Chemical				
Acid Fumes and Liquids	1	1	1	1
Alkaline Fumes and Liquids	1	1	1	1

Rating Code

- 4 - Excellent - Best seal for conditions listed.
 3 - Good - Sealability is above average.
 2 - Fair - Seal performs under intermittent conditions.
 1 - Limited - Actual conditions must be known to evaluate sealability. Check "General Characteristic Guide" for construction as well as benefits and limitations for further evaluation.
 0 - Not acceptable - Will not effectively perform seal functions. Contact Rexnord for special assistance in the realm of materials and designs.

Seal Speed Limit Table*

Size Code	203	204	205	206	207	208	209	210	211	212	213	215	217	220	
Bearing Series	CL		212	214 215 216	218 219 2E20	220 222 223	224	226 227 228	230 231 2E32	232 235 2E36	236 238 239	240 243	244 247 2E48	255 2E56	263 2E64
		Y	2B08 210 211	212	214 215 216	218 219 2E20	220 222 223	224	226 227 228	231 232 2E32	236 238 239				
	U	2B08 210 211	212	214 215 216	218 219 2E20	220 222 223	224	226 227 228	231 232 2E32	236 238 239	240 243	244 247 2E48	255 2E56	263 2E64	
	W	2B08 210	212	214 215 216	218 219 2E20	220 222 223	224	226 227 228	231 2E32						
	S		212	214 215 216	218 219 2E20	220 222 223	224	226 227 228	231						
(RPM)	Flingers	15800	13400	11400	9800	8400	7500	6800	6400	5800	5300	N/A	4400	N/A	N/A
	H	12000	10000	9600	8000	6850	6000	5330	4800	4360	4000	N/A	N/A	N/A	N/A
	E	9000	7500	6800	5600	4800	4500	4000	3600	N/A	N/A	N/A	N/A	N/A	N/A
	N	12000	10000	9600	8000	6850	6000	5330	4800	4360	4000	3850	3300	2950	2500
E3	N/A	N/A	1000	N/A	700	650	600	550	500	450	400	350	300	N/A	
Size Code	203	204	205	206	207	208	209	210	211	212	213	215	217	220	

Refer to Seal Rating Guide shown above for speeds in excess of those listed in this table.

* Actual bearing speed limits are largely based upon the applied load and can be found on the Load Rating Table.

Seal Availability by Size Code and Inner Race Style

	H	N	E	E3	MHFF	HFF	FF
203	CL	CL	CL		CL	CL	CL
	U	U	U		U	U	U
	Y	S	S		S	S	S
204	CL	CL	CL		CL	CL	CL
	U	U	U		U	U	U
	Y	S	S		S	S	S
205	CL	CL	CL	CL	CL	CL	CL
	U	U	U	U	U	U	U
	Y	S	S	Y	S	S	S
206	CL	CL	CL	CL	CL	CL	CL
	U	U	U	U	U	U	U
	Y	S	S	Y	S	S	S
207	CL	CL	CL	CL	CL	CL	CL
	U	U	U	U	U	U	U
	Y	S	S	Y	S	S	S
208	CL	CL	CL	CL	CL	CL	CL
	U	U	U	U	U	U	U
	Y	S	S	Y	S	S	S
209	CL	CL	CL	CL	CL	CL	CL
	U	U	U	U	U	U	U
	Y	S	S	Y	S	S	S
210	CL	CL	CL	CL	CL	CL	CL
	U	U	U	U	U	U	U
	Y	S	S	Y	S	S	S
211	CL	CL	CL	CL	CL	CL	CL
	U	U	U	U	U	U	U
	Y	S	S	Y	S	S	S
212	CL	CL	CL	CL	CL	CL	CL
	U	U	U	U	U	U	U
	Y	S	S	Y	S	S	S
213		CL	CL	CL	CL	CL	CL
		U	U	U	U	U	U
		S	S	S	S	S	S
215		CL	CL	CL	CL	CL	CL
		U	U	U	U	U	U
		S	S	S	S	S	S
217		CL	CL	CL	CL	CL	CL
		U	U	U	U	U	U
220		CL	CL	CL	CL	CL	CL
		U	U	U	U	U	U

200 Series Standard & Intermediate Duty End Cap Options

Size Code	Inner Ring Style	Pillow Blocks				Flange Blocks				Take-up Blocks	
		P3	PH3	PL3	PT3	FX3	F3	FB3	FC3	T3	TH3
203	CL	CL2116		CL2116		CL2116	CL2116				
	Y	CL2116		CL2116		CL2116	CL2116				
	U	CL2116		CL2116		CL2116	CL2116				
	W	CL2116		CL2116		CL2116	CL2116				
204	CL	CL2126		CL2126	CL2126	CL2126	CL2126	CL2126			CL2126
	Y	Y2126N		Y2126N	CL2126	Y2126N	Y2126N	Y2126N		Y2126	Y2126N
	U	Y2126N		Y2126N	CL2126	Y2126N	Y2126N	Y2126N		Y2126	Y2126N
	W	Y2126N		Y2126N	CL2126	Y2126N	Y2126N	Y2126N			Y2126N
205	CL	CL2166		CL2166	CL2166	CL2166	CL2166	CL2166	CL2166		CL2166
	Y	Y2166N		Y2166N	CL2166	Y2166N	Y2166N	Y2166N	Y2166N	Y2166	Y2166N
	U	Y2166N		Y2166N	CL2166	Y2166N	Y2166N	Y2166N	Y2166N	Y2166	Y2166N
	W	Y2166N		Y2166N	CL2166	Y2166N	Y2166N	Y2166N	Y2166N		Y2166N
206	CL	CL2196		CL2196	CL2196	CL2196	CL2196	CL2196	CL2196		CL2196
	Y	Y2196N	Y2196	Y2196N	CL2196	Y2196N	Y2196N	Y2196N	Y2196N	Y2196	Y2196N
	U	Y2196N	Y2196	Y2196N	CL2196	Y2196N	Y2196N	Y2196N	Y2196N	Y2196	Y2196N
	W	Y2196N		Y2196N	CL2196	Y2196N	Y2196N	Y2196N	Y2196N		Y2196N
207	CL	CL2236		CL2236	CL2236	CL2236	CL2236	CL2236	CL2236		CL2236
	Y	Y2236N	Y2236	Y2236N	CL2236	Y2236N	Y2236N	Y2236N	Y2236N	Y2236	Y2236N
	U	Y2236N	Y2236	Y2236N	CL2236	Y2236N	Y2236N	Y2236N	Y2236N	Y2236	Y2236N
	W	Y2236N		Y2236N	CL2236	Y2236N	Y2236N	Y2236N	Y2236N		Y2236N
208	CL	CL2256		CL2256	CL2256	CL2256	CL2256		CL2256		CL2256
	Y	Y2256N		Y2256N	CL2256	Y2256N	Y2256N		Y2256N	Y2256	Y2256N
	U	Y2256N		Y2256N	CL2256	Y2256N	Y2256N		Y2256N	Y2256	Y2256N
	W	Y2256N		Y2256N	CL2256	Y2256N	Y2256N		Y2256N		Y2256N
209	CL	CL2286		CL2286	CL2286	CL2286	CL2286		CL2286		CL2286
	Y	Y2286N	Y2286	Y2286N	CL2286	Y2286N	Y2286N		Y2286N	Y2286	Y2286N
	U	Y2286N	Y2286	Y2286N	CL2286	Y2286N	Y2286N		Y2286N	Y2286	Y2286N
	W	Y2286N		Y2286N	CL2286	Y2286N	Y2286N		Y2286N		Y2286N
210	CL	CL2316		CL2316	CL2316	CL2316	CL2316		CL2316		CL2316
	Y	Y2316N	Y2316	Y2316N	CL2316	Y2316N	Y2316N		Y2316N	Y2316	Y2316N
	U	Y2316N	Y2316	Y2316N	CL2316	Y2316N	Y2316N		Y2316N	Y2316	Y2316N
	W	Y2316N		Y2316N	CL2316	Y2316N	Y2316N		Y2316N		Y2316N
211	CL	CL2356		CL2356		CL2356	CL2356		CL2356		CL2356
	Y	CL2356	Y2356	CL2356		Y2356	Y2356		Y2356	Y2356	Y2356
	U	CL2356	Y2356	CL2356		Y2356	Y2356		Y2356	Y2356	Y2356
	S	CL2356		CL2356							
212	CL	CL2396		CL2396			CL2396		CL2396		CL2396
	Y	CL2396	Y2396	CL2396			Y2396		Y2396		Y2396
	U	CL2396	Y2396	CL2396			Y2396		Y2396		Y2396
	S	CL2396		CL2396							
213	CL										
	U	U2436C					U2436C		U2436C		
215	CL	CL2486					CL2486		CL2486		
	U	U2476C					U2476C		U2476C		
	S										
217	CL										
	U	U2556C					U2556C		U2556C		
220	CL										
	U	U2636C							U2636C		

No offering

Requires non-standard housing

Caps ending in "6N" are polypropylene material, all others are steel.

Caps not available in housing styles not listed.

200 Series Ball Bearings Selection Guide

To select a bearing, determine the applied radial load, the applied thrust load, the desired Rating Life, and applicable operating conditions. The procedure shown here will aid in selecting a bearing to meet an L_{10} design life. The formulas for calculating life expectancy should be used to determine the Rating Life L_{10} for the bearing selected.

The selection procedures and rating formulas shown here are in agreement with The American Bearing Manufacturers Association Standards and ANSI/ABMA Standards STD 9-1990. Ratings are based on fatigue life. The Rating Life or fatigue life at 90% reliability is the usual basis for bearing selection.

Steps for Selection

Step 1

Determine an appropriate L_{10} design life.

Type of service	Operating time, hours per year	Design life, years	L_{10} design life, hours
Light seasonal usage	500 to 750	3-5	3,000
Heavy seasonal usage	1,400 to 1,600	4-6	8,000
Industrial—8 hour shift	2,000	10	20,000

Step 2

Determine a required $\left(\frac{C}{P}\right)$ from Table 1.

Step 3

Calculate the required C and select a ball bearing.

a For radial load only:

$$P = F_r$$

$$\text{required } C = \left(\frac{C}{P}\right)P \text{ using } \left(\frac{C}{P}\right) \text{ from Step 2}$$

Select a ball bearing from Table 3 with a basic load rating C equal to or greater than the required C.

b For combined radial and thrust loads when $\frac{F_a}{F_r}$ is 0.19 or less:

$$P = F_r$$

$$\text{required } C = \left(\frac{C}{P}\right)P \text{ using } \left(\frac{C}{P}\right) \text{ from Step 2}$$

Select a ball bearing from Table 3 with a basic load rating C equal to or greater than the required C.

Series C200, U200, Y200, and hex, square and round bore bearings have wide inner rings for load support; however, the S200 and W200 series are extended on one side only for compactness and low cost. In combination with its companion line of economically designed housings, this series is applicable to light or moderate duty requirements. Where non-relubricatable bearings are used, bearing life is often limited by grease life, which is in turn affected by operating conditions. Also, economically designed housings must be applied within proportionate load limits. To assure a satisfactory bearing application, fitting practice, mounting, lubrication, sealing, static rating, housing strength, operating conditions and maintenance must be considered.

Step 3 (continued)

c For combined radial and thrust loads when $\frac{F_a}{F_r}$ is greater than 0.19, use the following trial method:

$$\text{Maximum } P = .56F_r + 2.30F_a$$

$$\text{Maximum required } C = \left(\frac{C}{P}\right)P \text{ using } \left(\frac{C}{P}\right) \text{ from Step 2}$$

Select a trial ball bearing with a basic load rating C from Table 3 approximately equal to the maximum required C.

$$\text{With this trial bearing calculate: } \frac{F_a}{Nd^2}$$

Determine X and Y from Table 2.

Calculate P for the trial bearing.

$$P = XF_r + YF_a$$

$$\text{required } C = \left(\frac{C}{P}\right)P \text{ for the trial bearing using } \left(\frac{C}{P}\right) \text{ from Step 2}$$

Consult Table 3, basic load rating. If a smaller bearing meets or nearly meets the required C, its life expectancy can be calculated. Note: If the load P is greater than .25C for series C200, U200, Y200, hex, square, and round bore bearings or greater than .15C for series S200 and W200, consult Rexnord Bearing Products.

Selection

Symbols for formulas:

C = basic load rating, pounds (or newtons)

C_o = static load rating, pounds (or newtons)

e = a reference value

F_a = thrust load, pounds (or newtons)

F_r = radial load, pounds (or newtons)

L₁₀ = rating life, hours

n = speed, revolutions per minute

P = equivalent radial load, pounds (or newtons)

X = radial factor

Y = thrust factor

Table 1 • Relation of L₁₀ life and speed to $\left(\frac{C}{P}\right)$

Bearing life, hours L ₁₀	$\left(\frac{C}{P}\right)$ ratio									
	Speed, n									
	50	100	200	300	400	500	600	700	800	
3000	2.08	2.62	3.30	3.77	4.15	4.47	4.75	5.01	5.23	
4000	2.29	2.88	3.63	4.15	4.57	4.92	5.23	5.51	5.76	
5000	2.46	3.10	3.91	4.47	4.92	5.30	5.64	5.93	6.20	
6000	2.62	3.30	4.15	4.75	5.23	5.64	5.99	6.30	6.59	
8000	2.88	3.63	4.57	5.23	5.76	6.20	6.59	6.94	7.25	
10000	3.10	3.91	4.92	5.64	6.20	6.68	7.10	7.47	7.81	
12000	3.30	4.15	5.23	5.99	6.59	7.10	7.54	7.94	8.30	
14000	3.47	4.37	5.51	6.30	6.94	7.47	7.94	8.36	8.74	
16000	3.63	4.57	5.76	6.59	7.25	7.81	8.30	8.74	9.14	
18000	3.77	4.75	5.99	6.86	7.54	8.13	8.63	9.09	9.50	
20000	3.91	4.92	6.20	7.10	7.81	8.42	8.94	9.41	9.84	
25000	4.21	5.30	6.68	7.65	8.42	9.07	9.63	10.1	10.6	
30000	4.47	5.64	7.10	8.13	8.94	9.63	10.2	10.8	11.3	
35000	4.71	5.93	7.47	8.55	9.41	10.1	10.8	11.3	11.9	
40000	4.92	6.20	7.81	8.94	9.84	10.6	11.3	11.9	12.4	
45000	5.12	6.45	8.13	9.30	10.2	11.0	11.7	12.3	12.9	
50000	5.30	6.68	8.42	9.63	10.6	11.4	12.1	12.8	13.4	
60000	5.64	7.10	8.94	10.2	11.3	12.1	12.9	13.6	14.2	
70000	5.93	7.47	9.41	10.8	11.9	12.8	13.6	14.3	14.9	
80000	6.20	7.81	9.84	11.3	12.4	13.4	14.2	14.9	15.6	
90000	6.45	8.13	10.2	11.7	12.9	13.9	14.8	15.5	16.2	
100000	6.68	8.42	10.6	12.1	13.4	14.4	15.3	16.1	16.8	
150000	7.65	9.63	12.1	13.9	15.3	16.5	17.5	18.4	19.3	
200000	8.42	10.6	13.4	15.3	16.8	18.1	19.3	20.3	21.2	
	Speed, n									
	900	1000	1200	1500	1800	2400	3600	6000	10000	
3000	5.44	5.64	5.99	6.45	6.86	7.54	8.63	10.2	12.1	
4000	5.99	6.20	6.59	7.10	7.54	8.30	9.50	11.3	13.4	
5000	6.45	6.68	7.10	7.65	8.13	8.94	10.2	12.1	14.4	
6000	6.86	7.10	7.54	8.13	8.63	9.50	10.9	12.9	15.3	
8000	7.54	7.81	8.30	8.94	9.50	10.5	12.0	14.2	16.8	
10000	8.13	8.42	8.94	9.63	10.2	11.3	12.9	15.3	18.1	
12000	8.63	8.94	9.50	10.2	10.9	12.0	13.7	16.2	19.3	
14000	9.09	9.41	10.0	10.8	11.4	12.6	14.4	17.1	20.3	
16000	9.50	9.84	10.5	11.3	12.0	13.2	15.1	17.9	21.2	
18000	9.88	10.2	10.9	11.7	12.4	13.7	15.7	18.6	22.0	
20000	10.2	10.6	11.3	12.1	12.9	14.2	16.2	19.3	22.8	
25000	11.0	11.4	12.1	13.1	13.9	15.3	17.5	20.7	24.6	
30000	11.7	12.1	12.9	13.9	14.8	16.2	18.6	22.0	26.1	
35000	12.3	12.8	13.6	14.6	15.5	17.1	19.6	23.2	27.5	
40000	12.9	13.4	14.2	15.3	16.2	17.9	20.5	24.3	28.7	
45000	13.4	13.9	14.8	15.9	16.9	18.6	21.3	25.2	29.9	
50000	13.9	14.4	15.3	16.5	17.5	19.3	22.0	26.1	31.0	
60000	14.8	15.3	16.2	17.5	18.6	20.5	23.4	27.8	32.9	
70000	15.5	16.1	17.1	18.4	19.6	21.5	24.6	29.2	34.6	
80000	16.2	16.8	17.9	19.3	20.5	22.5	25.8	30.5	36.2	
90000	16.9	17.5	18.6	20.0	21.3	23.4	26.8	31.8	37.7	
100000	17.5	18.1	19.3	20.7	22.0	24.3	27.8	32.9	39.0	
150000	20.0	20.7	22.0	23.7	25.2	27.8	31.8	37.7	44.6	
200000	22.0	22.8	24.3	26.1	27.8	30.5	35.0	41.4	49.1	

Basic formula

$$\left(\frac{C}{P}\right) = \left(\frac{L_{10} \times n \times 60}{1,000,000}\right)^{1/3}$$

$$L_{10} = \frac{\left(\frac{C}{P}\right)^3 \times 1,000,000}{n \times 60}$$

Life Expectancy

To calculate the Rating Life L₁₀ of any selected or trial bearing:

Step 1 Determine the equivalent radial load P.

a For radial load only:
P = F_r

b For combined radial and thrust load:
P = X F_r + Y F_a using X and Y from Table 2 below.

Step 2 Calculate the ratio of basic load rating C to the equivalent radial load.

$$\left(\frac{C}{P}\right)$$

Step 3 Approximate the bearing life from Table 1.

Table 2 • X and Y factors for ball bearings

F _a Nd ²	e	F _a F _r ≤ e		F _a F _r > e	
		X	Y	X	Y
25	.19	1.0	0	.56	2.30
37.5	.21	1.0	0	.56	2.15
50	.22	1.0	0	.56	1.99
75	.24	1.0	0	.56	1.85
100	.26	1.0	0	.56	1.71
125	.27	1.0	0	.56	1.63
150	.28	1.0	0	.56	1.56
200	.30	1.0	0	.56	1.45
300	.34	1.0	0	.56	1.31
500	.38	1.0	0	.56	1.15
750	.42	1.0	0	.56	1.04
1000	.44	1.0	0	.56	1.00

For values between those in the table linear interpolation can be used.

Life Adjustment

The Rating Life, L₁₀, may be modified for some applications in accordance with the formula

$$L'_n = a_1 a_2 a_3 L_{10}$$

where L'_n = Adjusted life for (100-n) % reliability,

a₁ = Life adjustment factor for reliability

a₂ = Life adjustment factor for material and processing

a₃ = Life adjustment factor for operating conditions.

For most normal applications, all factors will be taken as 1, and the Rating Life used as the selection basis or life estimate. In addition, as long as standard catalog bearings are used, a₂ will be normally set equal to one. The factor a₃ covers such things as lubrication, misalignment, and temperature. Some conditions that could yield a₃ significantly different than unity include speeds less than 20000 DN or greater than 200000 DN, temperatures below -40°F (-40°C) or above 275°F (135°C). For other possible conditions, as well as additional information on life adjustment factors, consult Rexnord Bearing Products.

Table 3 • Load Ratings, Speed Limits and Ball Data

Size Code	C Basic load rating		Co Static load rating		Approximate speed limit RPM*				d Ball diameter	N Number of balls	Nd ²
	pounds	newtons	pounds	newtons	N & H Seals	E Seals‡	E3 Seals	Flingers	inches		
203	2360	10500	1110	4490	12000	9000		15800	19/64	7	0.617
204	2870	12800	1480	6590	10000	7500		13400	5/16	8	0.781
205	3150	14000	1760	7830	9600	6800	1000	11400	5/16	9	0.879
206	4390	19500	2530	11300	8000	5600		9800	3/8	9	1.27
207	5810	25800	3440	15300	6850	4800	700	8400	7/16	9	1.72
208	7330	32600	4460	19900	6000	4500	650	7500	1/2	9	2.25
209	7370	32800	4590	20400	5330	4000	600	6800	1/2	9	2.25
210	7920	35200	5220	23200	4800	3600	550	6400	1/2	10	2.50
211	9800	43600	6570	29200	4360	3200	500	5800	9/16	10	3.16
212	11840	52700	8080	36000	4000	3000	450	5300	5/8	10	3.91
213	12920	57500	9010	40100	3850	2850	400		21/32	10	4.31
215	15080	67000	11100	49200	3300	2700	350	4400	11/16	11	5.20
217	18850	83850	14300	63600	2950	2550	300	4050	25/32	11	6.71
220	27560	122550	20900	92900	2500	2250		3600	1	10	10.00

If the load P is greater than 15% of the C rating for S200 and W200 or 25% of the C rating for all others, consult Rexnord Bearing Division.

For U200, Y200, S200 and W200 Series reduce C Basic Load Rating by 23%

For CL200 Series reduce C Basic Load Rating by 15%.

* Based on grease lubrication and moderate load.

‡ E seal operation at higher speeds up to H seal speed limit is allowable providing the lip seal friction does not result in operating temperatures over 225°F (107°C).

Table 4 • Radial load ratings in pounds at various RPM for appropriate L₁₀ life hours

Bearing Size Number			Radial Load Ratings, Pounds																	
CL200 Y200 U200 W200 S200	Size Code	L ₁₀ Minimum life, hours	Speed, RPM																	
			50	100	200	300	400	500	600	700	800	900	1000	1200	1500	1800	2000	2500	3000	3500
2B08	203	8000	820	651	517	451	410	381	358	340	326	313	302	284	264	248	240	223	210	199
210		20000	604	480	381	333	302	281	264	251	240	231	223	210	195	183	177	164	154	147
211		40000	480	381	302	264	240	223	210	199	190	183	177	166	154	145	140	130	123	116
2M17		100000	353	281	223	195	177	164	154	147	140	135	130	123	114	107	103	96	90	86
212	204	8000	996	791	627	548	498	462	435	413	395	380	367	345	321	302	291	270	254	242
2M20		20000	734	582	462	404	367	341	321	304	291	280	270	254	236	222	215	199	187	178
		40000	582	462	367	321	291	270	254	242	231	222	215	202	187	176	170	158	149	141
		100000	429	341	270	236	215	199	187	178	170	164	158	149	138	130	125	116	110	104
214	205	8000	1095	869	690	603	548	508	478	454	435	418	403	380	352	332	320	297	280	266
215		20000	807	640	508	444	403	375	352	335	320	308	297	280	260	244	236	219	206	196
216		40000	640	508	403	352	320	297	280	266	254	244	236	222	206	194	187	174	164	155
2M25		100000	472	375	297	260	236	219	206	196	187	180	174	164	152	143	138	128	121	115
218	206	8000	1523	1209	960	838	762	707	665	632	605	581	561	528	490	461	445	413	389	370
219		20000	1122	891	707	618	561	521	490	466	445	428	413	389	361	340	328	305	287	272
2E20		40000	891	707	561	490	445	413	389	370	354	340	328	309	287	270	260	242	228	216
2M30		100000	656	521	413	361	328	305	287	272	260	250	242	228	211	199	192	178	168	159
220	207	8000	2015	1599	1269	1109	1007	935	880	836	799	769	742	698	648	610	589	547	515	489
222		20000	1484	1178	935	817	742	689	648	616	589	566	547	515	478	450	434	403	379	360
223		40000	1178	935	742	648	589	547	515	489	468	450	434	408	379	357	344	320	301	286
2M35		100000	868	689	547	478	434	403	379	360	344	331	320	301	279	263	254	236	222	211
224	208	8000	2542	2017	1601	1399	1271	1180	1110	1055	1009	970	936	881	818	770	743	690	649	617
2M40		20000	1873	1486	1180	1031	936	869	818	777	743	715	690	649	603	567	548	508	478	454
		40000	1486	1180	936	818	743	690	649	617	590	567	548	515	478	450	435	403	380	361
		100000	1095	869	690	603	548	508	478	454	435	418	403	380	352	332	320	297	280	266
226	209	8000	2555	2028	1610	1406	1278	1186	1116	1060	1014	975	941	886	822	774	747	694	653	620
227		20000	1883	1494	1186	1036	941	874	822	781	747	718	694	653	606	570	551	511	481	457
228		40000	1494	1186	941	822	747	694	653	620	593	570	551	518	481	453	437	406	382	363
2M45		100000	1101	874	694	606	551	511	481	457	437	420	406	382	354	333	322	299	281	267
231	210	8000	2745	2178	1729	1510	1372	1274	1199	1139	1089	1047	1011	952	883	831	803	745	701	666
2E32		20000	2022	1605	1274	1113	1011	939	883	839	803	772	745	701	651	612	591	549	517	491
2M50		40000	1605	1274	1011	883	803	745	701	666	637	612	591	556	517	486	469	436	410	389
		100000	1183	939	745	651	591	549	517	491	469	451	436	410	381	358	346	321	302	287
232	211	8000	3398	2697	2141	1870	1699	1577	1484	1410	1349	1297	1252	1178	1094	1029	994	922	868	825
235		20000	2504	1987	1577	1378	1252	1162	1094	1039	994	955	922	868	806	758	732	680	640	608
2M55		40000	1987	1577	1252	1094	994	922	868	825	789	758	732	689	640	602	581	539	508	482
		100000	1464	1162	922	806	732	680	640	608	581	559	539	508	471	443	428	397	374	355
			E3 SEALS																	
236	212	8000	4106	3259	2586	2259	2053	1906	1793	1704	1629	1567	1513	1423	1321	1243	1201	1114	1049	996
238		20000	3025	2401	1906	1665	1513	1404	1321	1255	1201	1154	1114	1049	974	916	885	821	773	734
239		40000	2401	1906	1513	1321	1201	1114	1049	996	953	916	885	832	773	727	702	652	613	583
2M60		100000	1769	1404	1114	974	885	821	773	734	702	675	652	613	569	536	517	480	452	429
			N & E SEALS																	
240	213	8000	4480	3556	2822	2465	2240	2079	1957	1859	1778	1709	1650	1553	1442	1357	1310	1216	1144	1087
243		20000	3301	2620	2079	1816	1650	1532	1442	1370	1310	1259	1216	1144	1062	1000	965	896	843	801
2M65		40000	2620	2079	1650	1442	1310	1216	1144	1087	1040	1000	965	908	843	793	766	711	669	636
		100000	1930	1532	1216	1062	965	896	843	801	766	737	711	669	621	585	564	524	493	468
244	215	8000	5228	4149	3293	2877	2614	2427	2284	2169	2075	1995	1926	1812	1683	1583	1529	1419	1335	
247		20000	3852	3057	2427	2120	1926	1788	1683	1598	1529	1470	1419	1335	1240	1167	1126	1046	984	
2E48		40000	3057	2427	1926	1683	1529	1419	1335	1269	1213	1167	1126	1060	984	926	894	830	781	
2M75		100000	2253	1788	1419	1240	1126	1046	984	935	894	860	830	781	725	682	659	611	575	
255	217	8000	6535	5187	4117	3596	3267	3033	2854	2711	2593	2494	2407	2266	2103	1979	1911	1774		
2E56		20000	4815	3822	3033	2650	2407	2235	2103	1998	1911	1837	1774	1669	1550	1458	1408	1307		
2M85		40000	3822	3033	2407	2103	1911	1774	1669	1586	1517	1458	1408	1325	1230	1157	1117	1037		
		100000	2816	2235	1774	1550	1408	1307	1230	1168	1117	1074	1037	976	906	853	823	764		
263	220	8000	9555	7583	6019	5258	4777	4435	4173	3964	3792	3646	3520	3312	3075	2894	2794			
2E64		20000	7040	5588	4435	3874	3520	3268	3075	2921	2794	2686	2593	2441	2266	2132	2058			
2M100		40000	5588	4435	3520	3075	2794	2593	2441	2318	2217	2132	2058	1937	1798	1692	1634			
		100000	4117	3268	2593	2266	2058	1911	1798	1708	1634	1571	1517	1427	1325	1247	1204			

If the load P is greater than 15% of the C rating for S200 and W200 or 25% of the C rating for all others, consult Rexnord Bearing Division.

For U200, Y200, S200 and W200 Series reduce C Basic Load Rating by 23%.

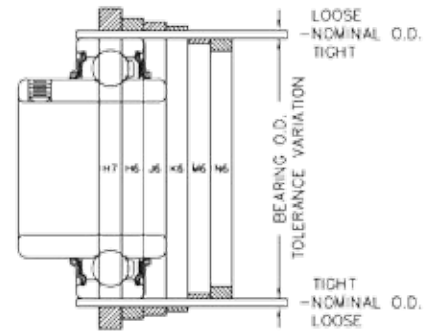
For CL200 Series reduce C Basic Load Rating by 15%.

Operation in the high speed shaded areas requires frequent lubrication.

Housing Bearing Seat Diameters For Cylindrical O.D. Ball Bearings

Class of fit selection

Housing Construction	Operating Condition		Class of fit*	Remarks
Housing not split radially	Housing rotating in relation to direction of load	Normal and heavy loads	N6	Outer ring not axially displaceable
		Light loads	M6	
	Direction of load indeterminate	Heavy shock loads	K6	Outer ring, as a rule, not axially displaceable
		Normal and heavy loads where outer ring does not have to be axially displaceable		
Housing split or not split radially	Housing stationary in relation to direction of loads	Normal and light loads where displaceability of outer ring is desirable	J6	Outer ring, as a rule, axially displaceable
		Shock loads temporary complete unloading	H6	
	All loads	Housing not split radially		H7
		Housing split radially		



*For cast iron or steel housings. For housings of light metal, select tolerances which give slightly tighter fits than those shown.

Class of fit and housing bores (inches/μm)

Basic Size				Bearing/housing diameter fits ▲													
W200, Y200, U200, C200	R200, S200, K200,	Nominal Bearing O.D. and Housing Bore		Bearing O.D. Tolerance △	H7		H6		J6		K6		M6		N6		
		mm	inches		Tolerance		Tolerance		Tolerance		Tolerance		Tolerance		Tolerance		
					Fit	Housing Bore	Fit	Housing Bore	Fit	Housing Bore	Fit	Housing Bore	Fit	Housing Bore	Fit	Housing Bore	
2M17	211	203	40	1.5748	+0.000	.0000	-.0000	.00000	-.0000	.0002T	-.0002	.0005T	-.0005	.0008T	-.0008	.0011T	-.0011
					-.0005	.0015L	+0.0010	.0011L	+0.0006	.0009L	+0.0004	.0006L	+0.0001	.0003L	-.0002	.0000	-.0005
					+0	0	-0	0	-0	5T	-5	13T	-13	20T	-20	28T	-28
					-13	38L	+25	28L	+15	23L	+10	15L	+2	8L	-5	0	-13
2M20	212	204	47	1.8504	+0.000	.0000	-.0000	.0000	-.0000	.0002T	-.0002	.0006T	-.0006	.0010T	-.0010	.0013T	-.0013
					-.0005	.0017L	+0.0012	.0012L	+0.0007	.0010L	+0.0005	.0006L	+0.0001	.0002L	-.0003	.0001T	-.0006
					+0	0	-0	0	-0	5T	-5	15T	-15	25T	-25	33T	-43
					-13	43L	+30	30L	+17	26L	+13	15L	+2	5L	-8	2T	-15
2M25	216	205	52	2.0472	+0.000	.0000	-.0000	.0000	-.0000	.0002T	-.0002	.0007T	-.0007	.0012T	-.0012	.0016T	-.0016
					-.0006	.0020L	+0.0014	.0015L	+0.0009	.0013L	+0.0007	.0008L	+0.0002	.0003L	-.0003	.0001T	-.0007
					+0	0	-0	0	-0	5T	-5	18T	-18	30T	-30	40T	-40
					-15	50L	+35	38L	+23	33L	+18	20L	+5	8L	-8	3T	-18
2M30	219	206	62	2.4409	+0.000	.0000	-.0000	.0000	-.0000	.0002T	-.0002	.0007T	-.0007	.0012T	-.0012	.0016T	-.0016
					-.0006	.0020L	+0.0014	.0015L	+0.0009	.0013L	+0.0007	.0008L	+0.0002	.0003L	-.0003	.0001T	-.0007
					+0	0	-0	0	-0	5T	-5	18T	-18	30T	-30	40T	-40
					-15	50L	+35	38L	+23	33L	+18	20L	+5	8L	-8	3T	-18
2M35	223	207	72	2.8346	+0.000	.0000	-.0000	.0000	-.0000	.0002T	-.0002	.0007T	-.0007	.0012T	-.0012	.0016T	-.0016
					-.0006	.0020L	+0.0014	.0015L	+0.0009	.0013L	+0.0007	.0008L	+0.0002	.0003L	-.0003	.0001T	-.0007
					+0	0	-0	0	-0	5T	-5	18T	-18	30T	-30	40T	-40
					-15	50L	+35	38L	+23	33L	+18	20L	+5	8L	-8	3T	-18
2M40	225	208	80	3.1496	+0.000	.0000	-.0000	.0000	-.0000	.0002T	-.0002	.0007T	-.0007	.0012T	-.0012	.0016T	-.0016
					-.0006	.0020L	+0.0014	.0015L	+0.0009	.0013L	+0.0007	.0008L	+0.0002	.0003L	-.0003	.0001T	-.0007
					+0	0	-0	0	-0	5T	-5	18T	-18	30T	-30	40T	-40
					-15	50L	+35	38L	+23	33L	+18	20L	+5	8L	-8	3T	-18
2M45	228	209	85	3.3465	+0.000	.0000	-.0000	.0000	-.0000	.0002T	-.0002	.0007T	-.0007	.0012T	-.0012	.0016T	-.0016
					-.0006	.0020L	+0.0014	.0015L	+0.0009	.0013L	+0.0007	.0008L	+0.0002	.0003L	-.0003	.0001T	-.0007
					+0	0	-0	0	-0	5T	-5	18T	-18	30T	-30	40T	-40
					-15	50L	+35	38L	+23	33L	+18	20L	+5	8L	-8	3T	-18
2M50	231	210	90	3.5433	+0.000	.0000	-.0000	.0000	-.0000	.0002T	-.0002	.0007T	-.0007	.0012T	-.0012	.0016T	-.0016
					-.0006	.0020L	+0.0014	.0015L	+0.0009	.0013L	+0.0007	.0008L	+0.0002	.0003L	-.0003	.0001T	-.0007
					+0	0	-0	0	-0	5T	-5	18T	-18	30T	-30	40T	-40
					-15	50L	+35	38L	+23	33L	+18	20L	+5	8L	-8	3T	-18
2M55	235	211	100	3.9370	+0.000	.0000	-.0000	.0000	-.0000	.0002T	-.0002	.0007T	-.0007	.0012T	-.0012	.0016T	-.0016
					-.0006	.0020L	+0.0014	.0015L	+0.0009	.0013L	+0.0007	.0008L	+0.0002	.0003L	-.0003	.0001T	-.0007
					+0	0	-0	0	-0	5T	-5	18T	-18	30T	-30	40T	-40
					-15	50L	+35	38L	+23	33L	+18	20L	+5	8L	-8	3T	-18
2M60	239	212	110	4.3307	+0.000	.0000	-.0000	.0000	-.0000	.0002T	-.0002	.0007T	-.0007	.0012T	-.0012	.0016T	-.0016
					-.0006	.0020L	+0.0014	.0015L	+0.0009	.0013L	+0.0007	.0008L	+0.0002	.0003L	-.0003	.0001T	-.0007
					+0	0	-0	0	-0	5T	-5	18T	-18	30T	-30	40T	-40
					-15	50L	+35	38L	+23	33L	+18	20L	+5	8L	-8	3T	-18

Please consult for availability.

1μm = .001 mm

The appropriate housing bore for any class of fit can be easily determined by applying the housing tolerance to the nominal housing bore.

Example, (using basic size 211 and class of fit H7):

	inches		mm	
Nominal housing bore	= 1.5748	1.5748	40.000	40.000
Housing bore tolerance	= -.0000	+.0010	-0.000	+0.025
Resultant housing bore	= 1.5748	1.5758	40.000	40.025

▲ Symbol L indicates a loose or clearance fit. Symbol T indicates a tight or interference fit.

△ The arithmetical mean of the largest and smallest single diameter to be within tolerance shown. Allowable deviations from mean diameter per ANSI/ABMA Standard 20, latest printing.

ER, ER-K Series Housing Fits

Size Code	Outside Diameter of Bearing		Rotating Housing				Stationary Housing			
			Diameter		Resultant Fit		Diameter		Resultant Fit	
	Min	Max	Min	Max	Loose	Tight	Min	Max	Loose	Tight
204	1.8499	1.8540	1.8498	1.8504	0.0005	0.0006	1.8503	1.8509	0.0010	0.0001
205	2.0466	2.0472	2.0466	2.0471	0.0005	0.0006	2.0471	2.0476	0.0010	0.0001
206	2.4403	2.4409	2.4403	2.4408	0.0005	0.0006	2.4408	2.4413	0.0010	0.0001
207	2.8340	2.8346	2.8340	2.8345	0.0005	0.0006	2.8345	2.8350	0.0010	0.0001
208	3.1490	3.1496	3.1490	3.1495	0.0005	0.0006	3.1495	3.1500	0.0010	0.0001
209	3.3457	3.3465	3.3458	3.3464	0.0007	0.0007	3.3464	3.3470	0.0013	0.0001
210	3.5425	3.5433	3.5426	3.5432	0.0007	0.0007	3.5432	3.5438	0.0013	0.0001
211	3.9362	3.9370	3.9363	3.9369	0.0007	0.0007	3.9369	3.9375	0.0013	0.0001
212	4.3299	4.3307	4.3300	4.3306	0.0007	0.0007	4.3306	4.3312	0.0013	0.0001
214	4.9203	4.9213	4.9204	4.9212	0.0009	0.0009	4.9211	4.9219	0.0016	0.0002
215	5.1171	5.1181	5.1172	5.1180	0.0009	0.0009	5.1179	5.1187	0.0016	0.0002
216	5.5108	5.5118	5.5109	5.5117	0.0009	0.0009	5.5116	5.5124	0.0016	0.0002

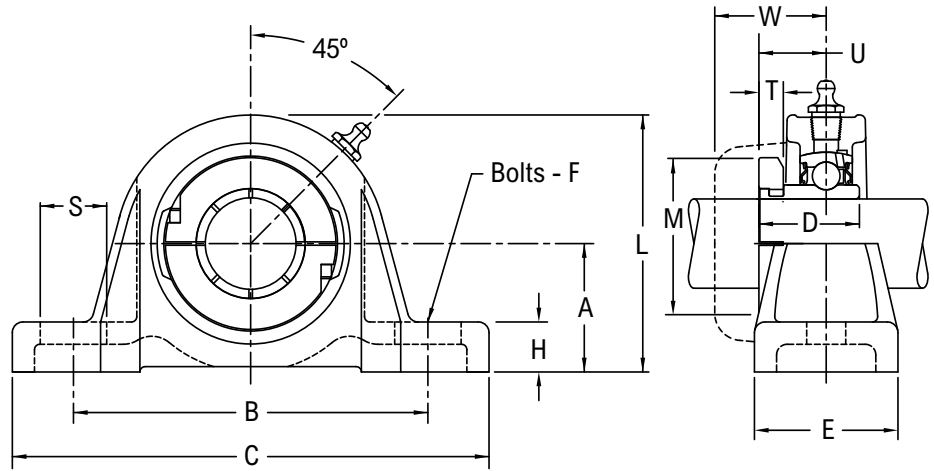
P3CL200N

Interchange: P2BDL, GRP200, NP-T



Product Features

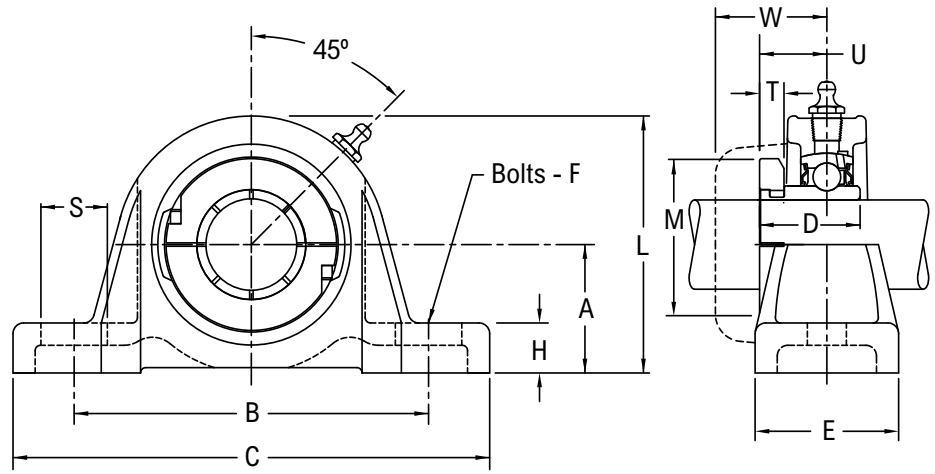
- Corrosion resistant powder coating
- Cast iron housing
- Broad range of sealing options
- Wide inner ring for increased shaft stability
- Centrik-Lok CL shaft locking device
- Alignable and relubricatable
- Black Oxide
- See Features and Benefits for additional info on pages 286 - 287.



Bearing Dimensions

Size Code	Shaft Diameter	Part Number	A Base to Centerline Height	B Distance Between Bolt Holes	C	D	E	F Bolts	H	L	M	S	U	W	Approx. Weight
203	1/2	P3CL2B08N *■	1 3/16	3 1/2	4 5/8	1 3/32	1 5/16	3/8	1/2	2 11/32	1 5/8	3/4	41/64	1 13/64	1.00
	5/8	P3CL210N *■													
	11/16	P3CL211N *■													
	17.00	P3CL2M17N *■	30.16	88.90	117.50	27.78	33.33	10.00	12.70	59.50	41.28	19.00	16.30	30.60	0.45
204	3/4	P3CL212N *■	1 5/16	3 7/8	5 1/8	1 9/32	1 7/16	3/8	1/2	2 19/32	2 1/16	3/4	3/4	1 19/64	1.70
	20.00	P3CL2M20N *■	33.34	98.40	130.20	32.54	36.51	10.00	12.70	65.90	52.39	19.00	19.00	32.90	0.76
205	7/8	P3CL214N Δ*■	1 7/16	4	5 3/8	1 23/64	1 21/64	3/8	9/16	2 7/8	2 13/64	3/4	51/64	1 9/32	1.90
	15/16	P3CL215N Δ*■													
	1	P3CL216N Δ*■													
	25.00	P3CL2M25N Δ*■	36.51	101.60	136.50	34.53	33.73	10.00	14.30	73.00	55.96	19.00	20.20	32.50	0.86
206	1 1/8	P3CL218N Δ*■	1 11/16	4 5/8	6 5/16	1 9/16	1 5/8	1/2	11/16	3 5/16	2 19/32	15/16	61/64	1 29/64	2.70
	1 3/16	P3CL219N Δ*■													
	1 1/4	P3CL2E20N Δ*■													
	30.00	P3CL2M30N Δ*■	42.86	117.50	160.30	39.69	41.27	12.00	17.50	84.10	65.88	23.80	24.20	36.90	1.22
207	1 1/4	P3CL220N Δ*■	1 7/8	4 15/16	6 3/8	1 49/64	1 3/4	1/2	13/16	3 11/16	3 3/64	7/8	1 7/64	1 35/64	3.70
	1 3/8	P3CL222N Δ*■													
	1 7/16	P3CL223N Δ*■													
	35.00	P3CL2M35N Δ*■	47.62	125.40	161.90	44.85	44.45	12.00	20.60	93.70	77.39	22.22	28.20	39.30	1.67
208	1 1/2	P3CL224N Δ*■	2	5 3/8	7 1/16	1 29/32	1 7/8	1/2	13/16	4	3 3/16	15/16	1 11/64	1 41/64	4.70
	40.00	P3CL2M40N Δ*■													
209	1 5/8	P3CL226N Δ*■	2 1/8	5 11/16	7 1/4	2 1/32	2	1/2	13/16	4 5/16	3 3/8	1	1 15/64	1 21/32	5.40
	1 11/16	P3CL227N Δ*■													
	1 3/4	P3CL228N Δ*■													
	45.00	P3CL2M45N Δ*■	53.98	144.46	184.20	51.59	50.80	12.00	20.60	109.50	85.73	25.40	31.40	42.10	2.43

Continued...



Continued...

Bearing Dimensions

Size Code	Shaft Diameter	Part Number	A Base to Centerline Height	B Distance Between Bolt Holes	C	D	E	F Bolts	H	L	M	S	U	W	Approx. Weight
210	1 ¹⁵ / ₁₆	P3CL231N Δ*	2 ¹ / ₄	6 ³ / ₁₆	7 ⁷ / ₈	2 ³ / ₃₂	2 ¹ / ₈	5/8	7/8	4 ⁹ / ₁₆	3 ³ / ₄	1 ¹⁵ / ₁₆	1 ¹⁷ / ₆₄	1 ²⁵ / ₃₂	6.10
	2	P3CL2E32N Δ*													
	50.00	P3CL2M50N Δ*	57.15	157.20	200.00	53.18	54.00	16.00	22.20	115.88	95.25	23.80	32.10	45.20	2.75
211	2	P3CL232N Δ*	2 ¹ / ₂	6 ²⁹ / ₃₂	8 ⁷ / ₈	2 ¹ / ₄	2 ⁵ / ₁₆	5/8	1	5	4 ⁵ / ₆₄	1 ⁷ / ₃₂	1 ¹³ / ₃₂	2 ¹ / ₆₄	7.80
	2 ³ / ₁₆	P3CL235N Δ*													
	55.00	P3CL2M55N Δ*	63.50	175.41	225.42	57.15	58.73	16.00	25.40	127.00	103.58	30.95	35.70	51.20	3.51
212	2 ¹ / ₄	P3CL236N Δ*	2 ¹¹ / ₁₆	7 ¹ / ₂	9 ¹ / ₂	2 ¹ / ₂	2 ³ / ₈	5/8	1 ¹ / ₈	5 ³ / ₈	4 ⁹ / ₃₂	1 ¹ / ₈	1 ⁹ / ₁₆	2 ⁷ / ₆₄	11.40
	2 ³ / ₈	P3CL238N Δ*													
	2 ⁷ / ₁₆	P3CL239N Δ*													
	60.00	P3CL2M60N Δ*	68.26	190.50	241.30	63.50	60.32	16.00	28.60	136.50	108.74	28.57	39.70	53.60	5.13
213	2 ¹ / ₂	P3CL240NΔ*	3	8 ¹ / ₈	10 ¹ / ₂	2 ³ / ₄	2 ⁷ / ₈	3/4	1 ⁵ / ₁₆	6	4 ⁵¹ / ₆₄	1 ³ / ₁₆	1 ³ / ₄	2 ¹⁵ / ₆₄	15.90
	2 ¹¹ / ₁₆	P3CL243NΔ*													
	65.00	P3CL2M65NΔ*													
215	2 ³ / ₄	P3CL244NΔ*	3 ¹ / ₄	8 ⁷ / ₈	11 ³ / ₄	2 ²⁹ / ₆₄	3 ¹ / ₄	3/4	1 ³ / ₈	6 ¹ / ₂	5 ¹ / ₄	1 ⁵ / ₁₆	1 ²⁷ / ₃₂	2 ²⁹ / ₆₄	19.50
	2 ¹⁵ / ₁₆	P3CL247NΔ*													
	3	P3CL2E48NΔ*													
	75.00	P3CL2M75NΔ*	82.55	225.40	298.40	74.22	82.60	20.00	34.90	165.10	133.35	33.30	46.83	62.31	8.78
217	3 ⁷ / ₁₆	P3CL255NΔ*	3 ³ / ₄	10	13	3 ³⁹ / ₆₄	3 ¹ / ₂	7/8	1 ⁵ / ₈	7 ⁷ / ₁₆	5 ²³ / ₃₂	1 ⁵ / ₈	2 ¹¹ / ₆₄	2 ⁵⁷ / ₆₄	28.70
	3 ¹ / ₂	P3CL2E56NΔ*													
	85.00	P3CL2M85NΔ*													
220	3 ¹⁵ / ₁₆	P3CL263N*	4 ⁷ / ₁₆	11 ⁷ / ₈	15 ¹ / ₄	4 ⁷ / ₆₄	4 ¹ / ₄	7/8	1 ¹³ / ₁₆	8 ⁷ / ₈	6 ¹ / ₂	1 ⁷ / ₈	2 ⁷ / ₁₆	3	50.20
	4	P3CL2E64N*													
	100.00	P3CL2M100N*													

Additional Notes

Please call 1-866-REXNORD for availability
 Lubrication fitting tap size: for size code 203, 1/4 in-28 UNF; for all other size codes, 1/8 in PT
 Base to centerline tolerance, +0.000 in/-0.010 in (+0.00 mm/-0.25 mm)
 * N lip seals standard
 ■ Available with H labyrinth seals

Δ Available with E3 triple lip seals
 Nickel plated housings available through all size codes, add suffix K75
 For the Selection Guide, Load Ratings and Speed Limits, see the Link-Belt 200 Series Ball Bearing Engineering section on pages 290 - 298.
 Note: Dimensions subject to change. Certified dimensions of ordered material furnished on request.

P3Y200

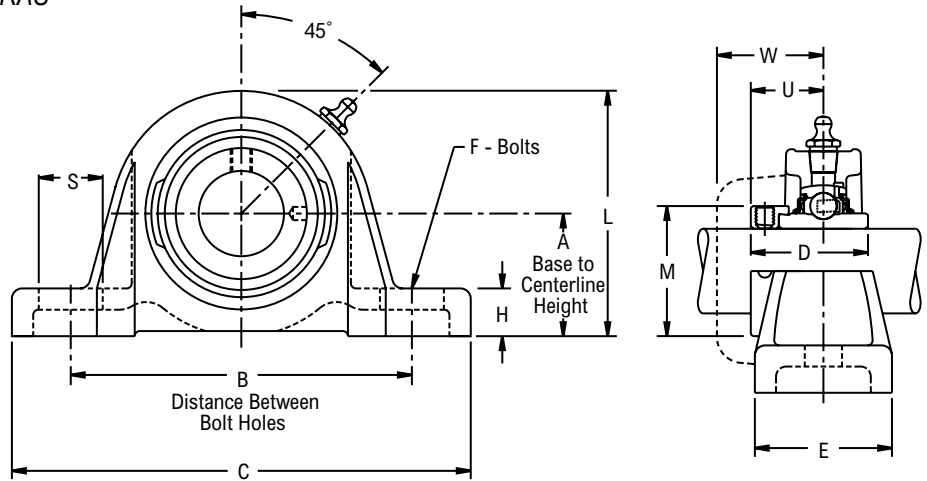
Interchange: P2BSXR, SY-WF, HCP200, RAS



Photo Shows a 2-Bolt Ball Bearing Pillow Block Unit

Product Features

- Corrosion-resistant powder coating
- Cast iron housing
- Broad range of sealing options
- Wide inner ring for increased shaft stability
- Eccentric cam locking device
- Alignable & relubricatable
- See Features and Benefits for additional info on pages 286 - 287.



Bearing Dimensions

Size Code	Shaft Diameter	Part Number	A Base to Centerline Height	B Distance Between Bolt Holes	C	D	E	F Bolts	H	L	M	S	U	W	Approx. Weight
203	1/2	P3Y2B08N *■	1 3/16	3 1/2	4 5/8	1 15/32	1 5/16	3/8	1/2	2 11/32	1 1/8	3/4	59/64	1 13/64	1.10
	5/8	P3Y210N *■													
	11/16	P3Y211N *■													
204	3/4	P3Y212N *■	1 5/16	3 7/8	5 1/8	1 23/32	1 7/16	3/8	1/2	2 19/32	1 5/16	3/4	1 3/64	1 19/64	1.80
	7/8	P3Y214N *△■													
205	15/16	P3Y215N *△■	1 7/16	4	5 3/8	1 3/4	1 21/64	3/8	9/16	2 7/8	1 1/2	3/4	1 1/16	1 9/32	2.00
	1	P3Y216N *△■													
	1 1/8	P3Y218N *△■													
206	1 3/16	P3Y219N *△■	1 11/16	4 5/8	6 5/16	1 29/32	1 5/8	1/2	11/16	3 5/16	1 3/4	15/16	1 3/16	1 29/64	2.80
	1 1/4	P3Y2E20N *△■													
	1 1/4	P3Y220N *△■													
207	1 3/8	P3Y222N *△■	1 7/8	4 15/16	6 3/8	2 1/64	1 3/4	1/2	13/16	3 11/16	2 3/16	7/8	1 9/32	1 35/64	4.00
	1 7/16	P3Y223N *△■													
	1 1/2	P3Y224N *△■													
208	1 5/8	P3Y226N *△■	2	5 3/8	7 1/16	2 7/32	1 7/8	1/2	13/16	4	2 3/8	15/16	1 3/8	1 41/64	5.00
	1 1/2	P3Y227N *△■													
	1 3/4	P3Y228N *△■													
209	1 15/16	P3Y231N *△■	2 1/4	6 3/16	7 7/8	2 15/32	2 1/8	5/8	7/8	4 1/2	2 3/4	15/16	1 1/2	1 25/32	6.40
	2	P3Y2E32N *△■													
	2	P3Y232N *△■													
211	2 3/16	P3Y235N *△■	2 1/2	6 29/32	8 7/8	2 13/16	2 5/16	5/8	1	5	3	1 7/32	1 23/32	2 1/64	8.40
	2 1/4	P3Y236N *△■													
	2 3/8	P3Y238N *△■													
212	2 7/16	P3Y239N *△■	2 11/16	7 1/2	9 1/2	3 1/16	2 3/8	5/8	1 1/8	5 3/8	3 5/16	1 1/8	1 27/32	2 7/64	11.60
	2 7/16	P3Y239N *△■													

Additional Notes

- Please call 1-866-REXNORD for availability
- Lubrication fitting tap size: for size code 203, 1/4 in-28 UNF: for all other size codes, 1/8 in PT
- Base to centerline tolerance, +.000 in/-0.010 in (+0.00 mm/-0.25 mm)
- * N lip seals standard
- Available with H labyrinth seals

- △ Available with E3 triple lip seals
- Nickel plated housings available, add suffix K75
- For the Selection Guide, Load Ratings and Speed Limits, see the Link-Belt 200 Series Ball Bearing Engineering section on pages 290 - 298.
- Note: Dimensions subject to change. Certified dimensions of ordered material furnished on request.

P3U200

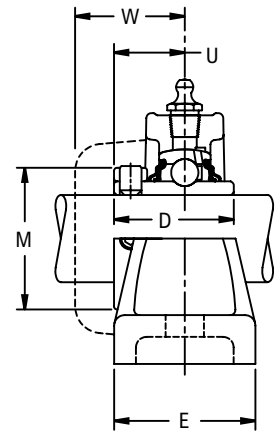
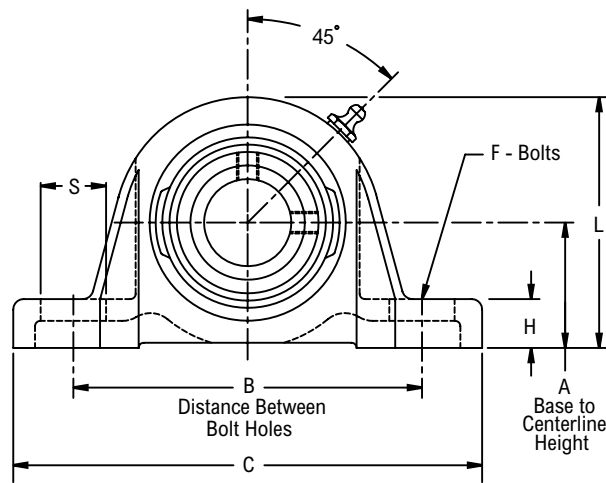
Interchange: P2BSC, SY-TF, UCP200, NP, YAS



Photo Shows a 2-Bolt Ball Bearing Pillow Block Unit

Product Features

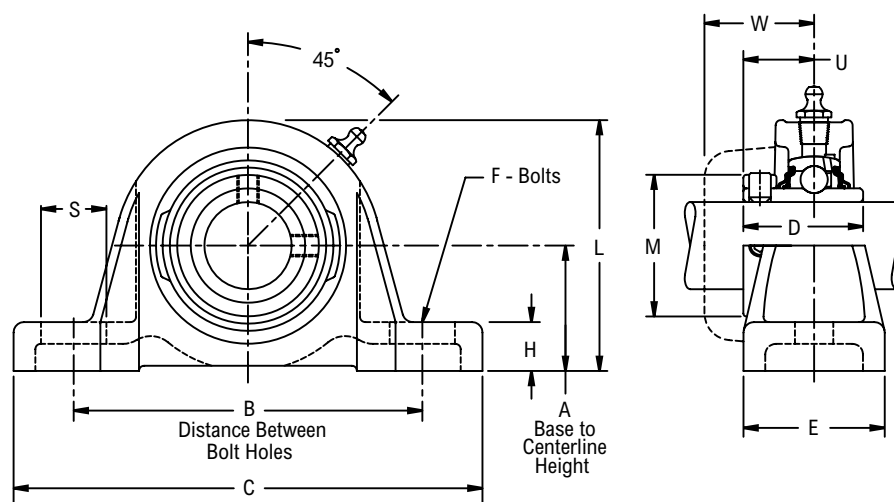
- Corrosion-resistant powder coating
- Cast iron housing
- Broad range of sealing options
- Wide inner ring for increased shaft stability
- Spring locking setscrew mount
- Alignable & relubricatable
- See Features and Benefits for additional info on pages 286 - 287.



Bearing Dimensions

Size Code	Shaft Diameter	Part Number	A Base to Centerline Height	B Distance Between Bolt Holes	C	D	E	F Bolts	H	L	M	S	U	W	Approx. Weight
203	1/2	P3U2B08N *■	1 3/16	3 1/2	4 5/8	1 3/32	1 5/16	3/8	1/2	2 11/32	-	3/4	41/64	1 13/64	1.00
	5/8	P3U210N *■													
	11/16	P3U211N *■													
204	17.00	P3U2M17N *■	30.16	88.90	117.50	27.78	33.33	10.00	12.70	59.50	-	19.00	16.30	30.60	0.45
	3/4	P3U212N *■	1 5/16	3 7/8	5 1/8	1 9/32	1 7/16	3/8	1/2	2 19/32	-	3/4	3/4	1 19/64	1.70
205	20.00	P3U2M20N *■	33.34	98.40	130.20	32.54	36.51	10.00	12.70	65.90	-	19.00	19.00	32.90	0.76
	7/8	P3U214N *Δ■	1 7/16	4	5 3/8	1 23/64	1 21/64	3/8	9/16	2 7/8	-	3/4	51/64	1 9/32	1.90
15/16	P3U215N *Δ■														
1	P3U216N *Δ■														
206	25.00	P3U2M25N *Δ■	36.51	101.60	136.50	34.53	33.73	10.00	14.30	73.00	-	19.00	20.20	32.50	0.86
	1 1/8	P3U218N *Δ■	1 11/16	4 5/8	6 3/16	1 9/16	1 5/8	1/2	11/16	3 5/16	-	15/16	61/64	1 29/64	2.70
1 3/16	P3U219N *Δ■														
1 1/4	P3U2E20N *Δ■														
207	30.00	P3U2M30N *Δ■	42.86	117.50	160.30	39.69	41.27	12.00	17.50	84.10	-	23.80	24.20	36.90	1.22
	1 1/4	P3U220N Δ*■	1 7/8	4 15/16	6 3/8	1 49/64	1 3/4	1/2	13/16	3 11/16	-	7/8	1 7/64	1 35/64	3.70
1 3/8	P3U222N Δ*■														
1 7/16	P3U223N Δ*■														
208	35.00	P3U2M35N Δ*■	47.62	125.40	161.90	44.85	44.45	12.00	20.60	93.70	-	22.22	28.20	39.30	1.67
	1 1/2	P3U224N Δ*■	2	5 3/8	7 1/16	1 29/32	1 7/8	1/2	13/16	4	-	15/16	1 11/64	1 41/64	4.70
40.00	P3U2M40N Δ*■														
1 5/8	P3U226N Δ*■														
209	45.00	P3U2M45N Δ*■	53.98	144.46	184.20	51.59	50.80	12.00	20.60	109.50	-	25.40	31.40	42.10	2.43
	1 11/16	P3U227N Δ*■	2 1/8	5 11/16	7 1/4	2 1/32	2	1/2	13/16	4 5/16	-	1	1 15/64	1 21/32	5.40
1 3/4	P3U228N Δ*■														
50.00	P3U2M50N Δ*■														
210	55.00	P3U2M55N Δ*■	63.50	175.41	225.42	57.15	58.73	16.00	25.40	127.00	-	30.95	35.70	51.20	3.51
	1 15/16	P3U231N Δ*■	2 1/4	6 3/16	7 7/8	2 3/32	2 1/8	5/8	7/8	4 1/2	-	15/16	1 17/64	1 25/32	6.10
2	P3U2E32N Δ*■														
50.00	P3U2M50N Δ*■														
211	55.00	P3U2M55N Δ*■	63.50	175.41	225.42	57.15	58.73	16.00	25.40	127.00	-	30.95	35.70	51.20	3.51
	2	P3U232N Δ*■	2 1/2	6 29/32	8 7/8	2 1/4	2 5/16	5/8	1	5	-	1 7/32	1 13/32	2 1/64	7.80
2 3/16	P3U235N Δ*■														
55.00	P3U2M55N Δ*■														
212	60.00	P3U2M60N Δ*■	68.26	190.50	241.30	63.50	60.32	16.00	28.60	136.50	-	28.57	39.70	53.60	5.13
	2 1/4	P3U236N Δ*■	2 11/16	7 1/2	9 1/2	2 1/2	2 3/8	5/8	1 1/8	5 3/8	-	1 1/8	1 9/16	2 7/64	11.40
2 3/8	P3U238N Δ*■														
2 7/16	P3U239N Δ*■														

Continued...



Continued...

Bearing Dimensions

Size Code	Shaft Diameter	Part Number	A Base to Centerline Height	B Distance Between Bolt Holes	C	D	E	F Bolts	H	L	M	S	U	W	Approx. Weight
213	2 1/2	P3U240NA*	3	8 1/8	10 1/2	2 11/16	2 7/8	3/4	1 5/16	6	4 3/16	1 3/16	1 11/16	2 1/16	15.90
	2 11/16	P3U243NA*													
	65.00	P3U2M65NA*	76.20	206.40	266.70	68.26	73.00	20.00	33.30	152.40	106.40	30.20	42.90	52.40	7.16
215	2 3/4	P3U244NA*	3 1/4	8 7/8	11 3/4	2 7/8	3 1/4	3/4	1 3/8	6 1/2	4 5/8	1 5/16	1 13/16	2 7/32	19.50
	2 15/16	P3U247NA*													
	3	P3U2E48NA*	75.00	225.40	298.40	73.02	82.60	20.00	34.90	165.10	117.50	33.30	46.00	56.40	8.78
217	3 7/16	P3U255NA*	3 3/4	10	13	3 9/16	3 1/2	7/8	1 5/8	7 7/16	5 3/16	1 5/8	2 1/8	2 1/2	28.70
	3 1/2	P3U2E56NA*													
	85.00	P3U2M85NA* Δ	95.25	254.00	330.20	90.49	88.90	24.00	41.30	188.90	131.80	41.30	54.00	63.50	12.92
220	3 15/16	P3U263N*	4 7/16	11 7/8	15 1/4	4 1/4	4 1/4	7/8	1 13/16	8 7/8	5 15/16	1 7/8	2 37/64	3 1/64	50.20
	4	P3U2E64N*													
	100.00	P3U2M100N*	112.71	301.60	387.40	107.95	108.00	24.00	46.00	225.40	150.80	47.60	65.50	76.60	22.60

Additional Notes

Please call 1-866-REXNORD for availability
 Lubrication fitting tap size: for size code 203, 1/4 in-28 UNF; for all other size codes, 1/8 in PT
 Base to centerline tolerance, +.000 in/-0.010 in (+0.00 mm/-0.25 mm)
 Size codes 203 to 212 don't have mounting collars
 * N lip seals standard
 ■ Available with H labyrinth seals

Δ Available with E3 triple lip seals
 Nickel plated housings available in all size codes
 For the Selection Guide, Load Ratings and Speed Limits, see the Link-Belt 200 Series Ball Bearing Engineering section on pages 290 - 298.
 Note: Dimensions subject to change. Certified dimensions of ordered material furnished on request.

P3W200

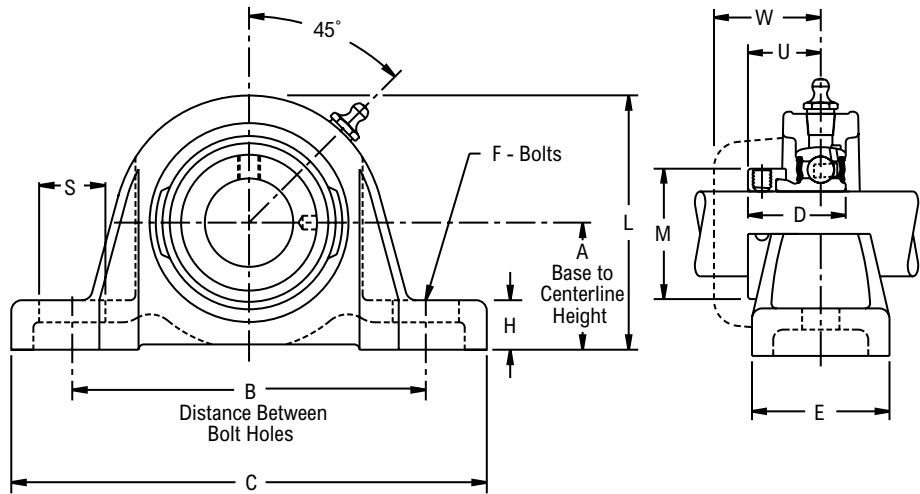
Interchange: P2BSXV, SY-FM, FHP200-G, VPE100, VAS



Photo Shows a 2-Bolt Ball Bearing Pillow Block Unit

Product Features

- Corrosion-resistant powder coating
- Cast iron housing
- Eccentric cam locking device
- Alignable & relubricatable
- See Features and Benefits for additional info on pages 286 - 287.



Bearing Dimensions

Size Code	Shaft Diameter	Part Number	A Base to Centerline Height	B Distance Between Bolt Holes	C	D	E	F Bolts	H	L	M	S	U	W	Approx. Weight
203	1/2	P3W2B08E ▲	1 3/16	3 1/2	4 5/8	1 1/8	1 5/16	3/8	1/2	2 11/32	1 1/8	3/4	7/8	1 13/64	0.90
	5/8	P3W210E ▲													
204	3/4	P3W212E ▲	1 9/16	3 7/8	5 1/8	1 7/32	1 7/16	3/8	1/2	2 19/32	1 5/16	3/4	59/64	1 19/64	1.60
	7/8	P3W214E ▲													
205	15/16	P3W215E ▲	1 7/16	4	5 3/8	1 7/32	1 21/64	3/8	9/16	2 7/8	1 1/2	3/4	59/64	1 9/32	1.80
	1	P3W216E ▲													
	1 1/8	P3W218E ▲													
206	1 3/16	P3W219E ▲	1 11/16	4 5/8	6 5/16	1 13/32	1 5/8	1/2	11/16	3 5/16	1 3/4	15/16	1 3/64	1 29/64	2.50
	1 1/4	P3W220E ▲													
	1 3/8	P3W222E ▲													
207	1 7/16	P3W223E ▲	1 7/8	4 15/16	6 3/8	1 17/32	1 3/4	1/2	13/16	3 11/16	2 3/16	13/16	1 5/32	1 35/64	3.70
	1 1/2	P3W224E ▲													
208	1 1/2	P3W224E ▲	2	5 3/8	7 1/16	1 23/32	1 7/8	1/2	13/16	4	2 3/8	15/16	1 9/32	1 41/64	4.60
	1 5/8	P3W226E ▲													
209	1 11/16	P3W227E ▲	2 1/8	5 11/16	7 1/4	1 23/32	2	1/2	13/16	4 5/16	2 1/2	1	1 9/32	1 21/32	5.00
	1 3/4	P3W228E ▲													
	1 15/16	P3W231E ▲													
210	2	P3W2E32E ▲	2 1/4	6 3/16	7 7/8	1 23/32	2 1/8	5/8	7/8	4 9/16	2 3/4	15/16	1 9/32	1 25/32	5.50

Additional Notes

- Please call 1-866-REXNORD for availability
- Lubrication fitting tap size: for size code 203, 1/4 in-28 UNF; for all other size codes, 1/8 in PT
- Base to centerline tolerance, +.000 in/-0.010 in (+0.00 mm/-0.25 mm)
- ▲ E lip seals standard
- Nickel plated housings available, add suffix K75

For the Selection Guide, Load Ratings and Speed Limits, see the Link-Belt 200 Series Ball Bearing Engineering section on pages 290 - 298.

Note: Dimensions subject to change. Certified dimensions of ordered material furnished on request.

P3S200

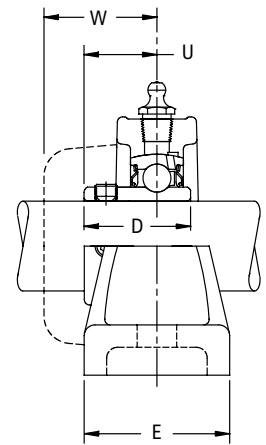
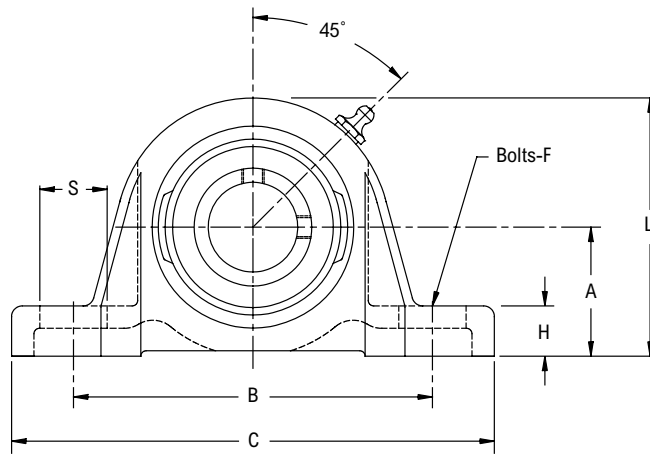
Interchange: P2BVSC, SY-RM, FHSP200-G, VPS100, SAS



Photo Shows a 2-Bolt Ball Bearing Pillow Block Unit

Product Features

- Corrosion-resistant powder coating
- Cast iron housing
- Broad range of sealing options
- Spring locking setscrew mount
- Alignable & relubricatable
- See Features and Benefits for additional info on pages 286 - 287.



Bearing Dimensions

Size Code	Shaft Diameter	Part Number	A Base to Centerline Height	B Distance Between Bolt Holes	C	D	E	F Bolts	H	L	S	U	W	Approx. Weight
203	1/2	P3S2B08E♦♦ □Δ	1 3/16	3 1/2	4 5/8	63/64	1 5/16	3/8	1/2	2 11/32	3/4	41/64	1 13/64	1.11
	5/8	P3S210E♦♦ □Δ												1.07
	11/16	P3S211E♦♦ □Δ												1.05
204	3/4	P3S212E♦♦ □Δ	1 5/16	3 7/8	5 1/8	1 1/8	1 7/16	3/8	1/2	2 19/32	3/4	3/4	1 19/64	1.51
	20.00	P3S2M20E♦♦ □Δ	33.32	98.40	130.20	28.58	36.52	10.00	12.70	65.90	19.00	19.00	32.90	0.70
205	7/8	P3S214E♦♦ □Δ	1 7/16	4	5 3/8	1 11/64	1 21/64	3/8	9/16	2 7/8	3/4	51/64	1 9/32	1.81
	15/16	P3S215E♦♦ □Δ												1.78
	1	P3S216E♦♦ □Δ												1.75
	25.00	P3S2M25E♦♦ □Δ												36.52
206	1 1/8	P3S218E♦♦ □Δ	1 11/16	4 5/8	6 5/16	1 11/32	1 5/8	1/2	1 1/16	3 5/16	15/16	61/64	1 29/64	2.45
	1 3/16	P3S219E♦♦ □Δ												2.42
	1 1/4	P3S220E♦♦ □Δ												2.39
	30.00	P3S2M30E♦♦ □Δ												42.88
207	1 1/4	P3S220E♦♦ □Δ	1 7/8	4 15/16	6 3/8	1 9/16	1 3/4	1/2	13/16	3 11/16	7/8	1 7/64	1 35/64	3.57
	1 3/8	P3S222E♦♦ □Δ												3.47
	1 7/16	P3S223E♦♦ □Δ												3.41
	35.00	P3S2M35E♦♦ □Δ												47.62
208	1 1/2	P3S224E♦♦ □Δ	2 1/8	5 3/8	7 1/16	1 21/32	1 7/8	1/2	13/16	4	15/16	1 11/64	1 41/64	4.60
	1 5/8	P3S226E♦♦ □Δ												4.46
	40.00	P3S2M40E♦♦ □Δ												53.98
209	1 5/8	P3S226E♦♦ □Δ	2 1/8	5 11/16	7 1/4	1 49/64	2	1/2	13/16	4 5/16	1	1 15/64	1 21/32	5.28
	1 11/16	P3S227E♦♦ □Δ												5.21
	1 3/4	P3S228E♦♦ □Δ												5.14
210	1 7/8	P3S230E♦♦ □Δ	2 1/4	6 3/16	7 7/8	1 13/16	2 1/8	5/8	7/8	4 9/16	15/16	1 17/64	1 25/32	6.28
	1 15/16	P3S231E♦♦ □Δ												6.19
	2	P3S2E32E♦♦ □Δ												6.10
211	2	P3S232E♦♦ □Δ	2 1/2	6 29/32	8 7/8	1 13/16	2 5/16	5/8	1	5	1 7/32	1 9/32	2 1/64	7.78
	2 3/16	P3S235E♦♦ □Δ												7.48
	2 1/4	P3S2E36E♦♦ □Δ												7.38
212	2 1/4	P3S236E♦♦ □Δ	2 3/4	7 1/2	9 1/2	1 57/64	2 3/8	5/8	1 7/64	5 3/8	1 1/8	1 5/16	2 7/64	10.12
	2 3/8	P3S238E♦♦ □Δ												9.88
	2 7/16	P3S239E♦♦ □Δ												9.76
215	2 15/16	P3S247E♦♦ □Δ	3 1/2	8 7/8	12	2 17/64	2 7/8	7/8	1 7/32	6 21/32	1 5/16	1 15/32	2 7/32	16.73

Additional Notes

- Please call 1-866-REXNORD for availability
- Lubrication fitting tap size: for size codes 203 thru 205, 1/4-28 UNF: for all other size codes, 1/8 in PT
- Base to centerline tolerance, +/- .005 in (+/- 0.13 mm)
- Lip seals standard
- ♦ Available with E1 viton seals for all size codes

- ♦ Nickel plated housings available, add suffix K75
- Available with free running style seals, add suffix ♦ FF, □ HFF or Δ MHFF for all size codes
- For the Selection Guide, Load Ratings and Speed Limits, see the Link-Belt 200 Series Ball Bearing Engineering section on pages 290 - 298.
- Note: Dimensions subject to change. Certified dimensions of ordered material furnished on request.

PH3Y200

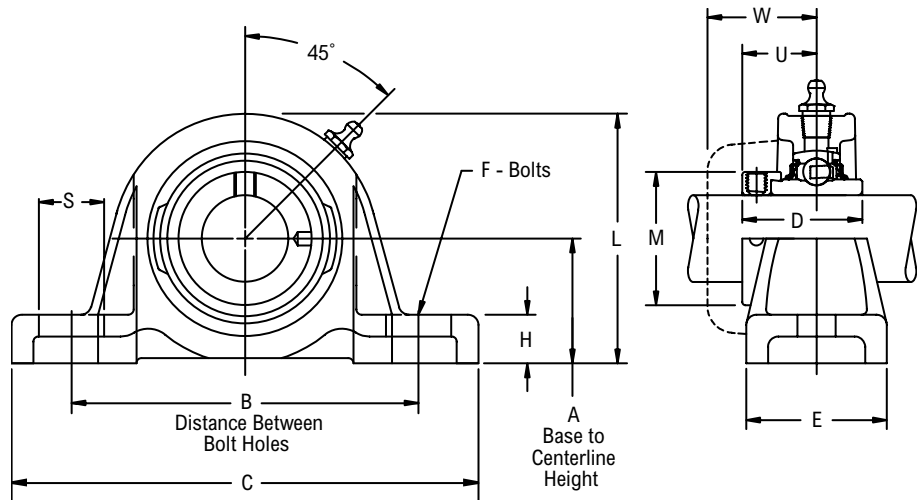
Interchange: P2BSXRU



Photo Shows a 2-Bolt Ball Bearing Pillow Block Unit

Product Features

- Corrosion-resistant powder coating
- Cast iron housing
- Broad range of sealing options
- Wide inner ring for increased shaft stability
- Eccentric cam locking device
- Alignable & relubricatable
- High base to center height
- See Features and Benefits for additional info on pages 286 - 287.



Bearing Dimensions

Size Code	Shaft Diameter	Part Number	A Base to Centerline Height	B Distance Between Bolt Holes	C	D	E	F Bolts	H	L	M	S	U	W	Approx. Weight
206	1 1/8	PH3Y218N *Δ	2	5 1/2	7	1 29/32	1 15/16	1/2	11/16	3 5/8	1 3/4	7/8	1 3/16	1 29/64	3.70
	1 3/16	PH3Y219N *Δ													
	1 1/4	PH3Y220N *Δ													
207	1 1/4	PH3Y220N *Δ	2 3/8	6 1/4	8 1/4	2 1/64	2 1/2	5/8	3/4	4 1/4	2 3/16	1 1/4	1 9/32	1 35/64	4.70
	1 3/8	PH3Y222N *Δ													
	1 7/16	PH3Y223N *Δ													
209	1 5/8	PH3Y226N *Δ	2 3/8	6 5/8	8 1/4	2 7/32	2 3/8	5/8	3/4	4 9/16	2 1/2	15/16	1 3/8	1 21/32	7.90
	1 11/16	PH3Y227N *Δ													
	1 3/4	PH3Y228N *Δ													
210	1 15/16	PH3Y231N *Δ	2 3/4	8 1/16	10 1/8	2 15/32	2 5/8	5/8	7/8	5	2 3/4	1 1/4	1 1/2	1 25/32	9.50
211	2	PH3Y232N *Δ	3 1/8	8 7/8	11 3/8	2 13/16	3	5/8	7/8	5 5/8	3	1 1/8	1 23/32	2 1/64	13.20
	2 3/16	PH3Y235N *Δ													
212	2 1/4	PH3Y236N *Δ	3 1/8	8 7/8	11 3/8	3 1/16	3	3/4	7/8	5 7/8	3 5/16	1 1/4	1 27/32	2 7/64	14.40
	2 3/8	PH3Y238N *Δ													
	2 7/16	PH3Y239N *Δ													

Additional Notes

- Please call 1-866-REXNORD for availability
- Lubrication fitting tap size, 1/8 in PT
- Base to centerline tolerance, +.000 in/-0.010 in (+0.00 mm/-0.25 mm)
- * N lip seals standard
- Available with H labyrinth seals
- Δ Available with E3 triple lip seals

For the Selection Guide, Load Ratings and Speed Limits, see the Link-Belt 200 Series Ball Bearing Engineering section on pages 290 - 298.
 Note: Dimensions subject to change. Certified dimensions of ordered material furnished on request.

PH3U200

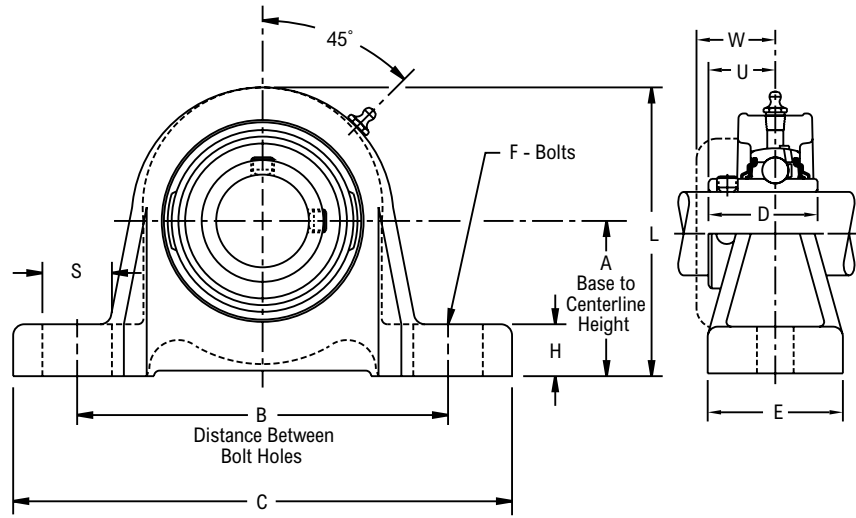
Interchange: P2BSCU



Photo Shows a 2-Bolt Ball Bearing Pillow Block Unit

Product Features

- Corrosion-resistant powder coating
- Cast iron housing
- Broad range of sealing options
- Wide inner ring for increased shaft stability
- Spring locking setscrew mount
- Alignable & relubricatable
- High base to center height
- See Features and Benefits for additional info on pages 286 - 287.



Bearing Dimensions

Size Code	Shaft Diameter	Part Number	A Base to Centerline Height	B Distance Between Bolt Holes	C	D	E	F Bolts	H	L	S	U	W	Approx. Weight
206	1 1/8	PH3U218N *Δ	2	5 1/2	7	1 9/16	1 15/16	1/2	1 1/16	3 5/8	7/8	61/64	1 29/64	3.80
	1 3/16	PH3U219N *Δ												
	1 1/4	PH3U220N *Δ												
	30.00	PH3U2M30N *Δ	50.80	139.70	177.80	39.69	49.20	12.00	17.50	92.10	22.20	24.20	36.90	1.71
207	1 1/4	PH3U220N *Δ	2 3/8	6 1/4	8 1/4	1 49/64	2 1/2	5/8	3/4	4 1/4	1 1/4	1 7/64	1 35/64	4.70
	1 3/8	PH3U222N *Δ												
	1 7/16	PH3U223N *Δ												
	35.00	PH3U2M35N *Δ	60.32	158.80	209.60	44.85	63.50	16.00	19.00	108.00	31.80	28.20	39.30	2.12
209	1 5/8	PH3U226N *Δ	2 3/8	6 5/8	8 1/4	2 1/32	2 3/8	5/8	3/4	4 9/16	15/16	1 15/64	1 21/32	7.90
	1 11/16	PH3U227N *Δ												
	1 3/4	PH3U228N *Δ												
	45.00	PH3U2M45N *Δ	60.32	168.30	209.60	51.59	60.30	16.00	19.00	115.90	23.80	31.40	42.10	3.56
210	1 15/16	PH3U231N *Δ	2 3/4	8 1/16	10 1/8	2 3/32	2 5/8	5/8	7/8	5	1 1/4	1 17/64	1 25/32	9.50
	50.00	PH3U2M50N *Δ												
211	2	PH3U232N *Δ	3 1/8	8 7/8	11 3/8	2 1/4	3	5/8	7/8	5 5/8	1 1/8	1 13/32	2 1/64	13.20
	2 3/16	PH3U235N *Δ												
	55.00	PH3U2M55N *Δ												
212	2 1/4	PH3U236N *Δ	3 1/8	8 7/8	11 3/8	2 1/2	3	3/4	7/8	5 7/8	1 1/4	1 9/16	2 7/64	14.40
	2 3/8	PH3U238N *Δ												
	2 7/16	PH3U239N *Δ												
	60.00	PH3U2M60N *Δ												

Additional Notes

- Please call 1-866-REXNORD for availability
- Lubrication fitting tap size, 1/8 in PT
- Base to centerline tolerance, +.000 in/-0.010 in (+0.00 mm/-0.25 mm)
- * N lip seals standard
- Available with H labyrinth seals
- Δ Available with E3 triple lip seals

For the Selection Guide, Load Ratings and Speed Limits, see the Link-Belt 200 Series Ball Bearing Engineering section on pages 290 - 298.
 Note: Dimensions subject to change. Certified dimensions of ordered material furnished on request.

PL3Y200

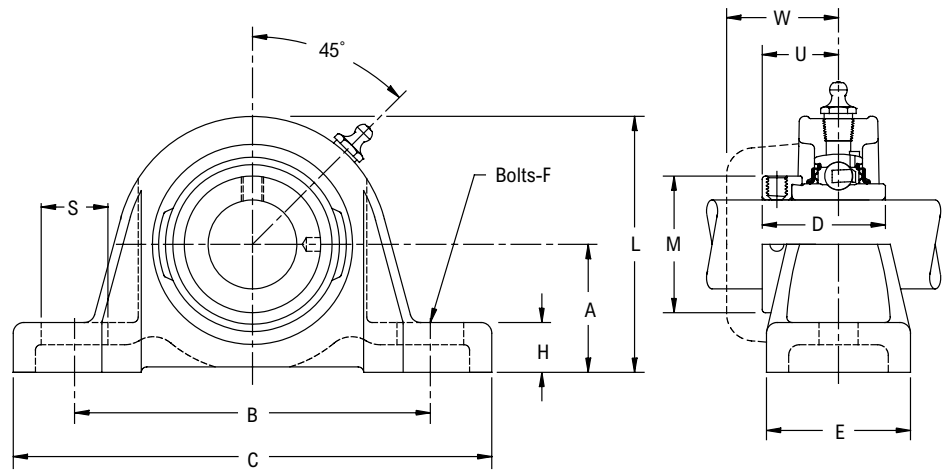
Interchange: P2BSXRB, SYH-WF, HCLP200, RAK



Photo Shows a 2-Bolt Ball Bearing Pillow Block Unit

Product Features

- Corrosion-resistant powder coating
- Cast iron housing
- Broad range of sealing options
- Wide inner ring for increased shaft stability
- Eccentric cam locking device
- Alignable & relubricatable
- Low base to center height
- See Features and Benefits for additional info on pages 286 - 287.



Bearing Dimensions

Size Code	Shaft Diameter	Part Number	A Base to Centerline Height	B Distance Between Bolt Holes	C	D	E	F Bolts	H	L	M	S	U	W	Approx. Weight
203	1/2	PL3Y2B08N *■	1 1/16	3 1/2	4 5/8	1 15/32	1 5/16	3/8	3/8	2 7/32	1 1/8	3/4	59/64	1 13/64	1.00
	5/8	PL3Y210N *■													
	11/16	PL3Y211N *■													
204	3/4	PL3Y212N *■	1 1/4	3 7/8	5 1/8	1 23/32	1 7/16	3/8	7/16	2 17/32	1 5/16	3/4	1 3/64	1 19/64	1.70
	7/8	PL3Y214N *Δ■													
205	15/16	PL3Y215N *Δ■	1 5/16	4	5 3/8	1 3/4	1 21/64	3/8	7/16	2 3/4	1 1/2	3/4	1 1/16	1 9/32	1.90
	1	PL3Y216N *Δ■													
206	1 1/8	PL3Y218N *Δ■	1 9/16	4 5/8	6 5/16	1 29/32	1 5/8	1/2	9/16	3 3/16	1 3/4	15/16	1 3/16	1 29/64	2.60
	1 3/16	PL3Y219N *Δ■													
	1 1/4	PL3Y2E20N *Δ■													
	1 1/4	PL3Y220N *Δ■													
207	1 3/8	PL3Y222N *Δ■	1 13/16	4 15/16	6 3/8	2 1/64	1 3/4	1/2	3/4	3 5/8	2 3/16	7/8	1 9/32	1 35/64	3.80
	1 7/16	PL3Y223N *Δ■													
	1 1/2	PL3Y224N *Δ■													
208	1 5/8	PL3Y226N *Δ■	1 15/16	5 3/8	7 1/16	2 7/32	1 7/8	1/2	47/64	3 15/16	2 3/8	15/16	1 3/8	1 41/64	4.80
	1 11/16	PL3Y227N *Δ■													
	1 3/4	PL3Y228N *Δ■													
209	1 15/16	PL3Y231N *Δ■	2 3/16	6 3/16	7 7/8	2 15/32	2 1/8	5/8	13/16	4 1/2	2 3/4	15/16	1 1/2	1 25/32	6.20
	2	PL3Y2E32N *Δ■													
210	2	PL3Y232N *Δ■	2 7/16	6 29/32	8 7/8	2 13/16	2 5/16	5/8	15/16	4 15/16	3	1 7/32	1 23/32	2 1/64	8.00
	2 3/16	PL3Y235N *Δ■													
	2 1/4	PL3Y236N *Δ■													
211	2 3/8	PL3Y238N *Δ■	2 11/16	7 1/2	9 1/2	3 1/16	2 1/2	5/8	1 1/8	5 3/8	3 5/16	1 1/8	1 27/32	2 7/64	11.60
	2 7/16	PL3Y239N *Δ■													
	2 7/16	PL3Y239N *Δ■													

Additional Notes

- Please call 1-866-REXNORD for availability
- Lubrication fitting tap size: for size code 203, 1/4 in-28 UNF; for all other size codes, 1/8 in PT
- Base to centerline tolerance, +.000 in/-0.010 in (+0.00 mm/-0.25 mm)
- * N lip seals standard
- Available with H labyrinth seals

Δ Available with E3 triple lip seals

For the Selection Guide, Load Ratings and Speed Limits, see the Link-Belt 200 Series Ball Bearing Engineering section on pages 290 - 298.

Note: Dimensions subject to change. Certified dimensions of ordered material furnished on request.

PL3U200

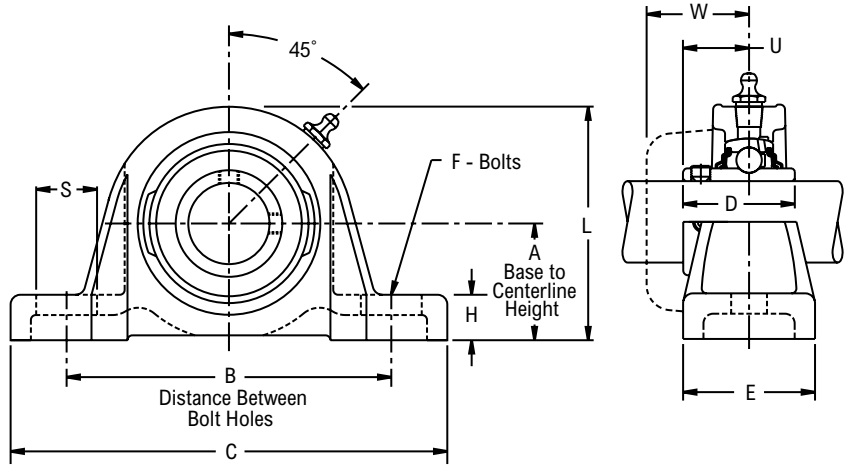
Interchange: P2BSCB, SYH-TF, UCLP200, NPL, YAK



Photo Shows a 2-Bolt Ball Bearing Pillow Block Unit

Product Features

- Corrosion-resistant powder coating
 - Cast iron housing
 - Broad range of sealing options
 - Wide inner ring for increased shaft stability
 - Spring locking setscrew mount
 - Alignable & relubricatable
 - Low base to center height
- See Features and Benefits for additional info on pages 286 - 287.



Bearing Dimensions

Size Code	Shaft Diameter	Part Number	A Base to Centerline Height	B Distance Between Bolt Holes	C	D	E	F Bolts	H	L	S	U	W	Approx. Weight
203	1/2	PL3U2B08N *■	1 1/16	3 1/2	4 5/8	1 3/32	1 5/16	3/8	3/8	2 7/32	3/4	4 1/64	1 13/64	0.90
	5/8	PL3U210N *■												
	11/16	PL3U211N *■												
204	17.00	PL3U2M17N *■	26.99	88.90	117.47	27.78	33.34	10.00	9.52	56.35	19.05	16.30	30.60	0.41
	3/4	PL3U212N *■	1 1/4	3 7/8	5 1/8	1 9/32	1 7/16	3/8	7/16	2 17/32	3/4	3/4	1 19/64	1.60
205	20.00	PL3U2M20N *■	31.75	98.40	130.20	32.54	36.51	10.00	11.10	64.30	19.05	19.00	32.90	0.72
	7/8	PL3U214N *▲	1 5/16	4	5 3/8	1 23/64	1 21/64	3/8	7/16	2 3/4	3/4	5 1/64	1 9/32	1.80
15/16	PL3U215N *▲													
1	PL3U216N *▲													
206	25.00	PL3U2M25N *▲	33.34	101.60	136.52	34.53	33.73	10.00	11.11	69.85	19.05	20.20	32.50	0.81
	1 1/8	PL3U218N *▲	1 9/16	4 5/8	6 5/16	1 9/16	1 5/8	1/2	9/16	3 3/16	15/16	6 1/64	1 29/64	2.50
1 3/16	PL3U219N *▲													
1 1/4	PL3U2E20N *▲													
207	30.00	PL3U2M30N *▲	39.69	117.47	160.30	39.69	41.27	12.00	14.28	80.96	23.81	24.20	36.90	1.13
	1 1/4	PL3U220N *▲	1 13/16	4 15/16	6 3/8	1 49/64	1 3/4	1/2	3/4	3 5/8	7/8	1 7/64	1 35/64	3.50
1 3/8	PL3U222N *▲													
1 7/16	PL3U223N *▲													
208	35.00	PL3U2M35N *▲	46.04	125.40	161.90	44.85	44.45	12.00	19.00	92.10	22.22	28.20	39.30	1.58
	1 1/2	PL3U224N *▲	1 15/16	5 3/8	7 1/16	1 29/32	1 7/8	1/2	47/64	3 15/16	15/16	1 11/64	1 41/64	4.50
40.00	PL3U2M40N *▲													
1 5/8	PL3U226N *▲													
209	45.00	PL3U2M45N *▲	52.39	144.46	184.20	51.59	50.80	12.00	19.00	108.00	25.40	31.40	42.10	2.34
	1 11/16	PL3U227N *▲	2 1/16	5 11/16	7 1/4	2 1/32	2	1/2	3/4	4 1/4	1	1 15/64	1 21/32	5.20
1 3/4	PL3U228N *▲													
50.00	PL3U2M50N *▲													
210	55.00	PL3U2M50N *▲	55.56	157.20	200.00	53.18	54.00	16.00	20.60	114.30	23.80	32.10	45.20	2.66
	1 15/16	PL3U231N *▲	2 3/16	6 3/16	7 7/8	2 3/32	2 1/8	5/8	13/16	4 1/2	15/16	1 17/64	1 25/32	5.90
2	PL3U2E32N *▲													
55.00	PL3U2M55N *▲													
211	60.00	PL3U2M55N *▲	61.91	175.41	225.42	57.15	58.73	16.00	23.80	125.40	30.95	35.70	51.20	3.33
	2	PL3U232N *▲	2 7/16	6 29/32	8 7/8	2 1/4	2 5/16	5/8	15/16	4 15/16	1 7/32	1 13/32	2 1/64	7.40
2 3/16	PL3U235N *▲													
55.00	PL3U2M55N *▲													
212	65.00	PL3U2M60N *▲	68.26	190.50	241.30	63.50	63.50	16.00	28.60	136.50	27.00	39.70	53.60	4.95
	2 1/4	PL3U236N *▲	2 11/16	7 1/2	9 1/2	2 1/2	2 1/2	5/8	1 1/8	5 3/8	1 1/16	1 9/16	2 7/64	11.00
2 3/8	PL3U238N *▲													
2 7/16	PL3U239N *▲													

Additional Notes

- Please call 1-866-REXNORD for availability
- Lubrication fitting tap size: for size code 203, 1/4 in-28 UNF: for all other size codes, 1/8 in PT
- Base to centerline tolerance, +.000 in/-0.010 in (+0.00 mm/-0.25 mm)
- * N lip seals standard
- Available with H labyrinth seals

- ▲ Available with E3 triple lip seals
- For the Selection Guide, Load Ratings and Speed Limits, see the Link-Belt 200 Series Ball Bearing Engineering section on pages 290 - 298.
- Note: Dimensions subject to change. Certified dimensions of ordered material furnished on request.

PL3W200

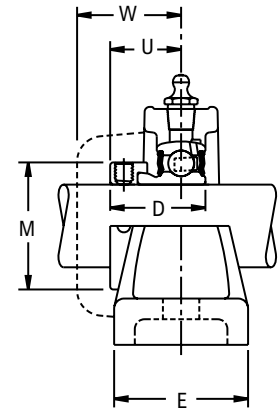
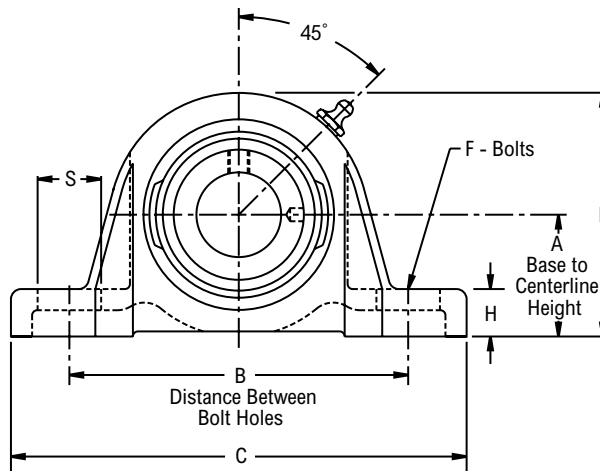
Interchange: P2BSXVB, SYH-FM, FHLP200-G, VPLE100, VAK



Photo Shows a 2-Bolt Ball Bearing Pillow Block Unit

Product Features

- Corrosion-resistant powder coating
- Cast iron housing
- Eccentric cam locking device
- Alignable & relubricatable
- Low base to center height
- See Features and Benefits for additional info on pages 286 - 287.



Bearing Dimensions

Size Code	Shaft Diameter	Part Number	A Base to Centerline Height	B Distance Between Bolt Holes	C	D	E	F Bolts	H	L	M	S	U	W	Approx. Weight
203	1/2	PL3W2B08E ▲	1 1/16	3 1/2	4 5/8	1 1/8	1 5/16	3/8	3/8	2 7/32	1 1/8	3/4	7/8	1 13/64	0.90
	5/8	PL3W210E ▲													
204	3/4	PL3W212E ▲	1 1/4	3 7/8	5 1/8	1 7/32	1 7/16	3/8	7/16	2 17/32	1 5/16	3/4	59/64	1 19/64	1.60
	7/8	PL3W214E ▲													
205	15/16	PL3W215E ▲	1 5/16	4	5 3/8	1 7/32	1 21/64	3/8	7/16	2 3/4	1 1/2	3/4	59/64	1 9/32	1.80
	1	PL3W216E ▲													
206	1 1/8	PL3W218E ▲	1 9/16	4 5/8	6 5/16	1 13/32	1 5/8	1/2	9/16	3 3/16	1 3/4	15/16	1 3/64	1 29/64	2.50
	1 3/16	PL3W219E ▲													
207	1 1/4	PL3W220E ▲	1 13/16	4 15/16	6 3/8	1 17/32	1 3/4	1/2	3/4	3 5/8	2 3/16	7/8	1 5/32	1 35/64	3.70
	1 3/8	PL3W222E ▲													
208	1 7/16	PL3W223E ▲	1 15/16	5 3/8	7 1/16	1 23/32	1 7/8	1/2	47/64	3 15/16	2 3/8	15/16	1 9/32	1 41/64	4.60
	1 1/2	PL3W224E ▲													
209	1 5/8	PL3W226E ▲	2 1/16	5 11/16	7 1/4	1 23/32	2	1/2	3/4	4 1/4	2 1/2	1	1 9/32	1 21/32	5.00
	1 11/16	PL3W227E ▲													
210	1 3/4	PL3W228E ▲	2 3/16	6 3/16	7 7/8	1 23/32	2 1/8	5/8	13/16	4 1/2	2 3/4	15/16	1 9/32	1 25/32	5.50
	1 15/16	PL3W231E ▲													
	2	PL3W2E32E ▲													

Additional Notes

- Please call 1-866-REXNORD for availability
- Lubrication fitting tap size: for size code 203, 1/4 in-28 UNF; for all other size codes, 1/8 in PT
- Base to centerline tolerance, +.000 in/-0.010 in (+0.00 mm/-0.25 mm)
- ▲ E lip seals standard

For the Selection Guide, Load Ratings and Speed Limits, see the Link-Belt 200 Series Ball Bearing Engineering section on pages 290 - 298.

Note: Dimensions subject to change. Certified dimensions of ordered material furnished on request.

PL3S200

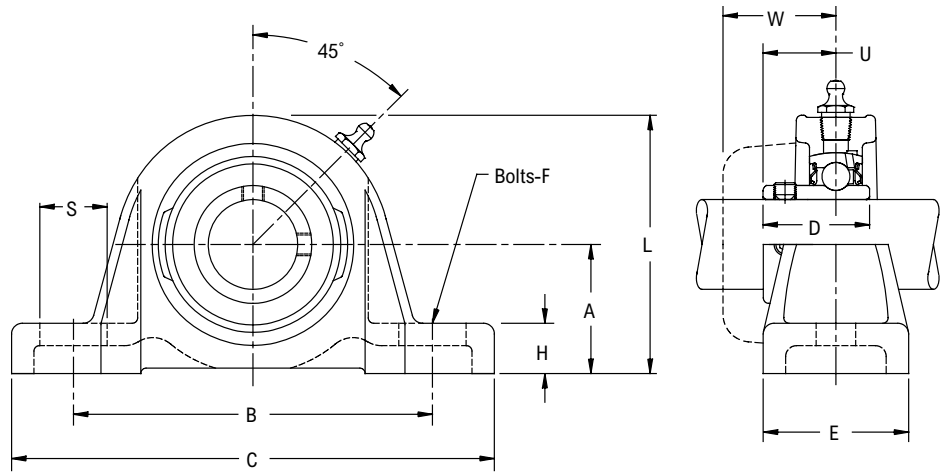
Interchange: P2BVSCB, SYH-RM, FHSLP200-G, VPL100, SAK



Photo Shows a 2-Bolt Ball Bearing Pillow Block Unit

Product Features

- Corrosion-resistant powder coating
- Cast iron housing
- Broad range of sealing options
- Spring locking setscrew mount
- Alignable & relubricatable
- Low base to center height
- See Features and Benefits for additional info on pages 286 - 287.



Bearing Dimensions

Size Code	Shaft Diameter	Part Number	A Base to Centerline Height	B Distance Between Bolt Holes	C	D	E	F Bolts	H	L	S	U	W	Approx. Weight
203	1/2	PL3S2B08E♦♦□Δ	1 1/16	3 1/2	4 5/8	63/64	1 5/16	3/8	3/8	2 7/32	3/4	41/64	1 13/64	1.06
	5/8	PL3S210E♦♦□Δ												1.02
	11/16	PL3S211E♦♦□Δ												1.00
204	3/4	PL3S212E♦♦□Δ	1 1/4	3 7/8	5 1/8	1 1/8	1 7/16	3/8	7/16	2 7/32	3/4	3/4	1 19/64	1.44
	20.00	PL3S2M20E♦♦□Δ	31.75	98.40	130.20	28.58	36.52	10.00	11.10	56.35	19.05	19.00	32.90	0.60
205	7/8	PL3S214E♦♦□Δ	1 5/16	4	5 3/8	1 11/64	1 21/64	3/8	7/16	2 3/4	3/4	51/64	1 9/32	1.71
	15/16	PL3S215E♦♦□Δ												1.68
	1	PL3S216E♦♦□Δ												1.67
	25.00	PL3S2M25E♦♦□Δ												33.32
206	1 1/8	PL3S218E♦♦□Δ	1 9/16	4 5/8	6 5/16	1 11/32	1 5/8	1/2	9/16	3 3/16	15/16	61/64	1 29/64	2.27
	1 3/16	PL3S219E♦♦□Δ												2.24
	1 1/4	PL3S220E♦♦□Δ												2.21
	30.00	PL3S2M30E♦♦□Δ												39.67
207	1 1/4	PL3S220E♦♦□Δ	1 13/16	4 15/16	6 3/8	1 9/16	1 3/4	1/2	3/4	3 5/8	7/8	1 7/64	1 35/64	3.47
	1 3/8	PL3S222E♦♦□Δ												3.37
	1 7/16	PL3S223E♦♦□Δ												3.31
	35.00	PL3S2M35E♦♦□Δ												46.02
208	1 1/2	PL3S224E♦♦□Δ	1 15/16	5 3/8	7 1/16	1 21/32	1 7/8	1/2	3/4	3 15/16	15/16	1 11/64	1 41/64	4.54
	1 5/8	PL3S226E♦♦□Δ												4.40
	40.00	PL3S2M40E♦♦□Δ												49.22
209	1 5/8	PL3S226E♦♦□Δ	2 1/16	5 11/16	7 1/4	1 49/64	2	1/2	3/4	4 1/4	1	1 15/64	1 21/32	5.22
	1 11/16	PL3S227E♦♦□Δ												5.15
	1 3/4	PL3S228E♦♦□Δ												5.08
210	1 7/8	PL3S230E♦♦□Δ	2 3/16	6 3/16	7 7/8	1 13/16	2 1/8	5/8	13/16	4 1/2	15/16	1 17/64	1 25/32	6.15
	1 15/16	PL3S231E♦♦□Δ												6.06
	2	PL3S232E♦♦□Δ												5.97
211	2	PL3S232E♦♦□Δ	2 7/16	6 29/32	8 7/8	1 13/16	2 5/16	5/8	15/16	4 15/16	1 7/32	1 9/32	2 1/64	7.61
	2 3/16	PL3S235E♦♦□Δ												7.31
	2 1/4	PL3S236E♦♦□Δ												7.21
212	2 1/4	PL3S236E♦♦□Δ	2 11/16	7 1/2	9 5/8	1 57/64	2 3/8	5/8	1	5 13/32	1 1/16	1 5/16	2 7/64	10.07
	2 3/8	PL3S238E♦♦□Δ												9.83
	2 7/16	PL3S239E♦♦□Δ												9.71
215	2 15/16	PL3S247E♦♦□Δ	3 5/16	9 1/8	12	2 17/64	2 7/8	7/8	1 1/32	6 15/32	1 7/8	1 15/32	2 7/32	16.23

Additional Notes

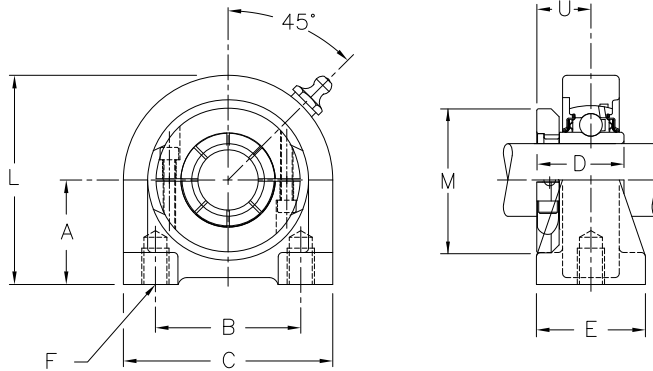
- Please call 1-866-REXNORD for availability
- Lubrication fitting tap size: for size codes 203 thru 205, 1/4-28 UNF; for all other size codes, 1/8 in PT
- Base to centerline tolerance, +/- .005 in (+/- 0.13 mm)
- Lip seals standard
- ♦ Available with E1 viton seals for all size codes

Available with free running style seals, add suffix ♦ FF, □ HFF or Δ MHFF for all size codes For the Selection Guide, Load Ratings and Speed Limits, see the Link-Belt 200 Series Ball Bearing Engineering section on pages 290 - 298.

Note: Dimensions subject to change. Certified dimensions of ordered material furnished on request.

PT3CL200N**Interchange:** *TBDL, TB-T*

Photo Shows a 2-Bolt Ball Bearing Tapped Base Pillow Block

**Product Features**

- Corrosion-resistant powder coating
- Cast iron tapped base housing
- Broad range of sealing options
- Wide inner ring for increased shaft stability
- Spring locking setscrew mount
- Alignable & relubricatable
- See Features and Benefits for additional info on pages 286 - 287.

Bearing Dimensions

Size Code	Shaft Diameter	Part Number	A Base to Centerline Height	B Distance Between Bolt Holes	C	D	E	F Depth	F Tap	L	M	U	Approx. Weight
204	3/4	PT3CL212N *■	1 5/16	2	2 7/8	1 11/32	1 1/2	1/2	3/8-16	2 19/32	1 15/16	1 13/16	1.20
	7/8	PT3CL214N *Δ											
205	15/16	PT3CL215N *Δ	1 7/16	2	2 7/8	1 3/8	1 1/2	1/2	3/8-16	2 7/8	2 5/64	57/64	1.40
	1	PT3CL216N *Δ											
206	1 1/8	PT3CL218N *Δ	1 11/16	3	4	1 9/16	1 1/2	5/8	7/16-14	3 5/16	2 15/32	29/32	2.50
	1 3/16	PT3CL219N *Δ											
	1 1/4	PT3CL2E20N *Δ											
207	1 1/4	PT3CL220N *Δ	1 7/8	3 1/4	4 13/32	1 3/4	2	3/4	1/2-13	3 11/16	2 7/8	1 1/32	3.40
	1 3/8	PT3CL222N *Δ											
	1 7/16	PT3CL223N *Δ											
208	1 1/2	PT3CL224N *Δ	1 15/16	3 1/2	4 5/8	1 15/16	1 7/8	3/4	1/2-13	3 15/16	3 3/64	1 11/64	3.67
	1 5/8	PT3CL2E26N *Δ											3.53
209	1 11/16	PT3CL227N *Δ	2 1/8	3 3/4	5	1 61/64	2	7/8	1/2-13	4 1/4	3 17/64	1 7/32	4.90
	1 3/4	PT3CL228N *Δ											
210	1 15/16	PT3CL231N *Δ	2 1/4	4	5 7/16	2 5/64	2	7/8	5/8-11	4 1/2	3 5/8	1 21/64	5.60
	2	PT3CL2E32N *Δ											

Additional Notes

- Please call 1-866-REXNORD for availability
- Lubrication fitting tap size, 1/8 in PT
- Base to centerline tolerance, +.000 in/-0.010 in (+0.00 mm/-0.25 mm)
- * N lip seals standard
- Available with H labyrinth seals
- Δ Available with E3 triple lip seals

For the Selection Guide, Load Ratings and Speed Limits, see the Link-Belt 200 Series Ball Bearing Engineering section on pages 290 - 298.

Note: Dimensions subject to change. Certified dimensions of ordered material furnished on request.

PT3U200

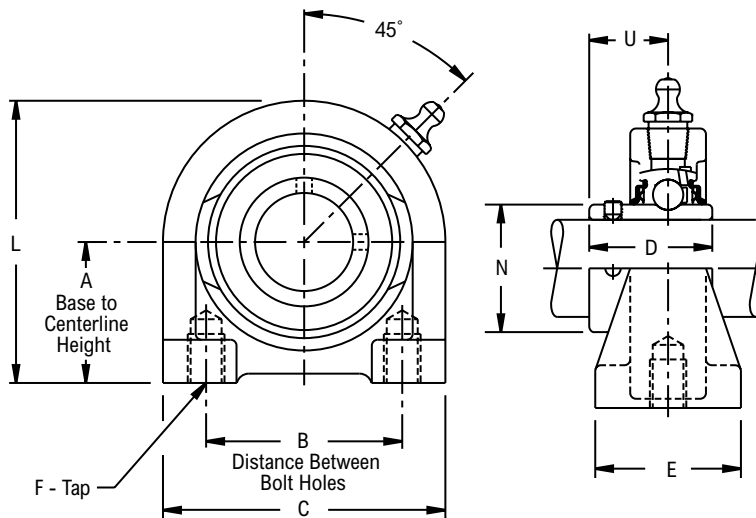
Interchange: TBSC, UCPAS200, TB, YTB



Photo Shows a 2-Bolt Ball Bearing Tapped Base Pillow Block

Product Features

- Corrosion-resistant powder coating
- Cast iron tapped base housing
- Broad range of sealing options
- Wide inner ring for increased shaft stability
- Spring locking setscrew mount
- Alignable & relubricatable
- See Features and Benefits for additional info on pages 286 - 287.



Bearing Dimensions

Size Code	Shaft Diameter	Part Number	A Base to Centerline Height	B Distance Between Bolt Holes	C	D	E	F Depth	F Tap	L	N	U	Approx. Weight
204	3/4	PT3U212N *■	1 5/16	2	2 7/8	1 9/32	1 1/2	1/2	3/8-16	2 19/32	1 1/8	3/4	1.20
205	7/8	PT3U214N *Δ	1 7/16	2	2 7/8	1 23/64	1 1/2	1/2	3/8-16	2 7/8	1 5/16	5 1/64	1.40
	15/16	PT3U215N *Δ											
	1	PT3U216N *Δ											
206	1 1/8	PT3U218N *Δ	1 11/16	3	4	1 9/16	1 1/2	5/8	7/16-14	3 5/16	1 19/32	6 1/64	2.50
	1 3/16	PT3U219N *Δ											
	1 1/4	PT3U220N *Δ											
207	1 1/4	PT3U220N *Δ	1 7/8	3 1/4	4 13/32	1 49/64	2	3/4	1/2-13	3 11/16	1 27/32	1 7/64	3.40
	1 3/8	PT3U222N *Δ											
	1 7/16	PT3U223N *Δ											
208	1 1/2	PT3U224N *Δ	1 15/16	3 1/2	4 5/8	1 29/32	1 7/8	3/4	1/2-13	3 15/16	2 3/32	1 11/64	3.67
209	1 11/16	PT3U227N *Δ	2 1/8	3 3/4	5	2 1/32	2	7/8	1/2-13	4 1/4	2 9/32	1 15/64	4.90
	1 3/4	PT3U228N *Δ											
210	1 15/16	PT3U231N *Δ	2 1/4	4	5 7/16	2 3/32	2	7/8	5/8-11	4 1/2	2 15/32	1 17/64	5.60
	2	PT3U232N *Δ											

Additional Notes

- Please call 1-866-REXNORD for availability
- Lubrication fitting tap size, 1/8 in PT
- Base to centerline tolerance, +.000 in/-0.010 in (+0.00 mm/-0.25 mm)
- * N lip seals standard
- Available with H labyrinth seals
- Δ Available with E3 triple lip seals

For the Selection Guide, Load Ratings and Speed Limits, see the Link-Belt 200 Series Ball Bearing Engineering section on pages 290 - 298.
 Note: Dimensions subject to change. Certified dimensions of ordered material furnished on request.

PT3S200

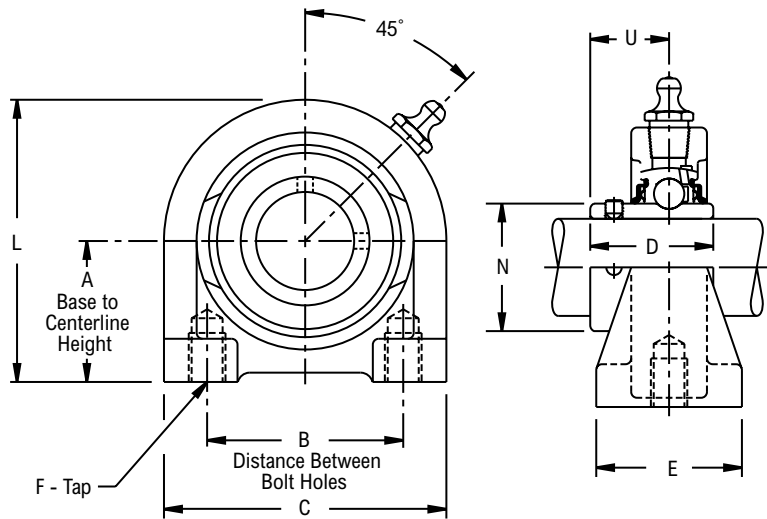
Interchange: TBVSC, STB



Photo Shows a 2-Bolt Ball Bearing Tapped Base Pillow Block

Product Features

- Corrosion-resistant powder coating
- Cast iron tapped base housing
- Broad range of sealing options
- Spring locking setscrew mount
- Alignable & relubricatable
- See Features and Benefits for additional info on pages 286 - 287.



Bearing Dimensions

Size Code	Shaft Diameter	Part Number	A Base to Centerline Height	B Distance Between Bolt Holes	F		C	D	E	L	U	Approx. Weight
					Depth	Tap						
203	1/2	PT3S2B08E♦♦ □Δ	1 5/16	2	1/2	3/8-16	2 7/8	63/64	1 5/16	2 13/32	4 1/64	1.06
	5/8	PT3S210E♦♦ □Δ										1.02
	1 1/16	PT3S211E♦♦ □Δ										1.00
204	3/4	PT3S212E♦♦ □Δ	1 5/16	2	1/2	3/8-16	2 7/8	1 1/8	1 1/2	2 19/32	3/4	1.20
	20.00	PT3S2M20E♦♦ □Δ										33.32
205	7/8	PT3S214E♦♦ □Δ	1 7/16	2	1/2	3/8-16	2 7/8	1 11/64	1 1/2	2 7/8	5 1/64	1.40
	15/16	PT3S215E♦♦ □Δ										1.37
	1	PT3S216E♦♦ □Δ										1.34
	25.00	PT3S2M25E♦♦ □Δ										36.52
206	1 1/8	PT3S218E♦♦ □Δ	1 11/16	3	5/8	7/16-14	4	1 11/32	1 1/2	3 5/16	6 1/64	2.35
	1 3/16	PT3S219E♦♦ □Δ										2.32
	1 1/4	PT3S2E20E♦♦ □Δ										2.29
	30.00	PT3S2M30E♦♦ □Δ										42.88
207	1 1/4	PT3S220E♦♦ □Δ	1 7/8	3 1/4	3/4	1/2-13	4 13/32	1 9/16	2	3 11/16	1 7/64	3.13
	1 3/8	PT3S222E♦♦ □Δ										3.03
	1 7/16	PT3S223E♦♦ □Δ										2.97
	35.00	PT3S2M35E♦♦ □Δ										47.62
208	1 1/2	PT3S224E♦♦ □Δ	1 15/16	3 1/2	3/4	1/2-13	4 5/8	1 21/32	1 7/8	3 15/16	1 11/64	3.67
	1 5/8	PT3S2E26E♦♦ □Δ										3.53
	40.00	PT3S2M40E♦♦ □Δ										49.22
209	1 5/8	PT3S226E♦♦ □Δ	2 1/8	3 3/4	7/8	1/2-13	5	1 49/64	2	4 1/4	1 15/64	4.75
	1 11/16	PT3S227E♦♦ □Δ										4.68
	1 3/4	PT3S228E♦♦ □Δ										4.61
	1 7/8	PT3S230E♦♦ □Δ										5.66
210	1 15/16	PT3S231E♦♦ □Δ	2 1/4	4	7/8	5/8-11	5 7/16	1 13/16	2	4 1/2	1 17/64	5.57
	2	PT3S2E32E♦♦ □Δ										5.48

Additional Notes

- Please call 1-866-REXNORD for availability
- Lubrication fitting tap, 1/8 in PT
- Base to centerline tolerance, +/- .005 in (+/- 0.13 mm)
- Lip seals standard
- ♦ Available with E1 viton seals
- Available with free running style seals, add suffix • FF, □ HFF or Δ MHFF

For the Selection Guide, Load Ratings and Speed Limits, see the Link-Belt 200 Series Ball Bearing Engineering section on pages 290 - 298.

Note: Dimensions subject to change. Certified dimensions of ordered material furnished on request.

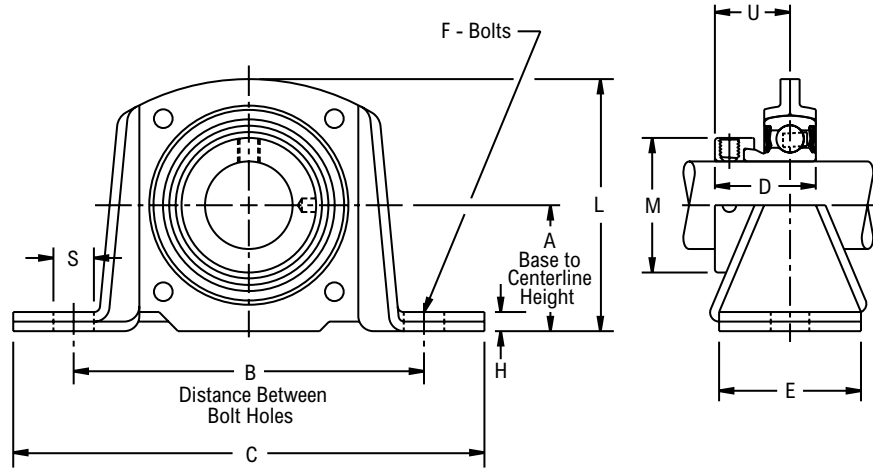
PSY200



Photo Shows a 2-Bolt Ball Bearing Pillow Block Unit with Stamped Steel Housing

Product Features

- Formed steel housing
- Broad range of sealing options
- Wide inner ring for increased shaft stability
- Eccentric cam locking device
- Alignable & non-relubricatable
- See Features and Benefits for additional info on pages 286 - 287.



Bearing Dimensions

Size Code	Shaft Diameter	Part Number	Radial Load Rating	A Base to Centerline Height	B Distance Between Bolt Holes	C	D	E	F Bolts	H	L	M	S	U	Approx. Weight
203	1/2	PSY2B08N *■	600	1 3/16	3 1/2	4 5/8	1 15/32	1 1/16	3/8	7/32	2 11/32	1 1/8	33/64	59/64	0.90
	5/8	PSY210N *■													
	11/16	PSY211N *■													
204	3/4	PSY212N *■	700	1 5/16	3 7/8	5 1/8	1 23/32	1 1/8	3/8	7/32	2 5/8	1 5/16	9/16	1 3/64	1.10
	7/8	PSY214N *Δ■													
205	15/16	PSY215N *Δ■	800	1 7/16	4 1/16	5 3/8	1 3/4	1 7/32	3/8	7/32	2 55/64	1 1/2	1/2	1 1/16	1.30
	1	PSY216N *Δ■													
	1 1/8	PSY218N *Δ■													
206	1 3/16	PSY219N *Δ■	985	1 11/16	4 49/64	6 5/16	1 29/32	1 7/16	1/2	5/16	3 5/16	1 3/4	49/64	1 3/16	2.00
	1 1/4	PSY220N *Δ■													
	1 1/4	PSY220N *Δ■													
207	1 1/4	PSY220N *Δ■	1,300	1 7/8	5 5/64	6 15/16	2 1/64	1 5/8	1/2	5/16	3 3/4	2 3/16	49/64	1 9/32	2.70
	1 3/8	PSY222N *Δ■													
	1 7/16	PSY223N *Δ■													

Additional Notes

Please call 1-866-REXNORD for availability

* N lip seals standard

■ Available with H labyrinth seals

Δ Available with E3 triple lip seals

For the Selection Guide, Load Ratings and Speed Limits, see the Link-Belt 200 Series Ball Bearing Engineering section on pages 290 - 298.

Note: Dimensions subject to change. Certified dimensions of ordered material furnished on request.

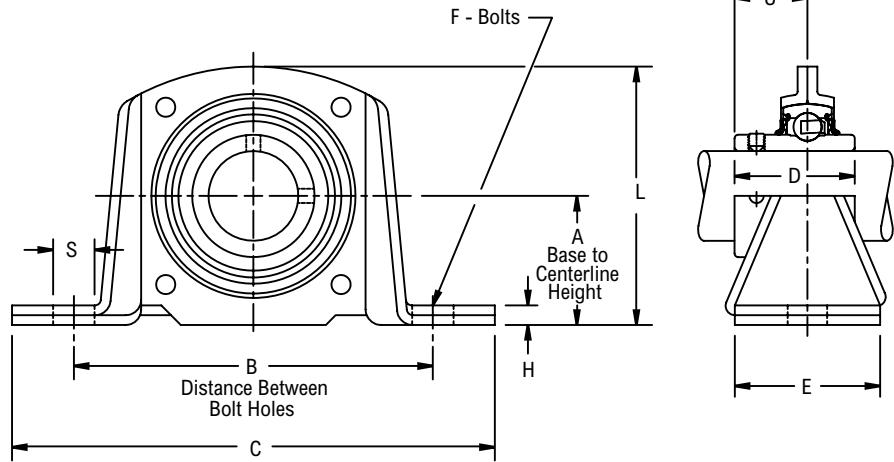
PSU200



Photo Shows a 2-Bolt Ball Bearing Pillow Block Unit with Stamped Steel Housing

Product Features

- Formed steel housing
- Broad range of sealing options
- Wide inner ring for increased shaft stability
- Spring locking setscrew mount
- Alignable & non-relubricatable
- See Features and Benefits for additional info on pages 286 - 287.



Bearing Dimensions

Size Code	Shaft Diameter	Part Number	Radial Load Rating	A Base to Centerline Height	B Distance Between Bolt Holes	C	D	E	F Bolts	H	L	S	U	Approx. Weight
203	1/2	PSU2B08N *■	600	1 3/16	3 1/2	4 5/8	1 3/32	1 1/16	3/8	7/32	2 11/32	33/64	41/64	0.90
	5/8	PSU210N *■												
	11/16	PSU211N *■												
204	3/4	PSU212N *■	700	1 5/16	3 7/8	5 1/8	1 9/32	1 1/8	3/8	7/32	2 5/8	9/16	3/4	1.10
	7/8	PSU214N *Δ■												
205	15/16	PSU215N *Δ■	800	1 7/16	4 1/16	5 3/8	1 23/64	1 7/32	3/8	7/32	2 55/64	1/2	51/64	1.30
	1	PSU216N *Δ■												
206	1 1/8	PSU218N *Δ■	985	1 11/16	4 49/64	6 5/16	1 9/16	1 7/16	1/2	5/16	3 5/16	49/64	61/64	2.00
	1 3/16	PSU219N *Δ■												
	1 1/4	PSU2E20N *Δ■												
207	1 1/4	PSU220N *Δ■	1,300	1 7/8	5 5/64	6 15/16	1 49/64	1 5/8	1/2	5/16	3 3/4	49/64	1 7/64	2.70
	1 3/8	PSU222N *Δ■												
	1 7/16	PSU223N *Δ■												

Additional Notes

Please call 1-866-REXNORD for availability

* N lip seals standard

■ Available with H labyrinth seals

Δ Available with E3 triple lip seals

For the Selection Guide, Load Ratings and Speed Limits, see the Link-Belt 200 Series Ball Bearing Engineering section on pages 290 - 298.

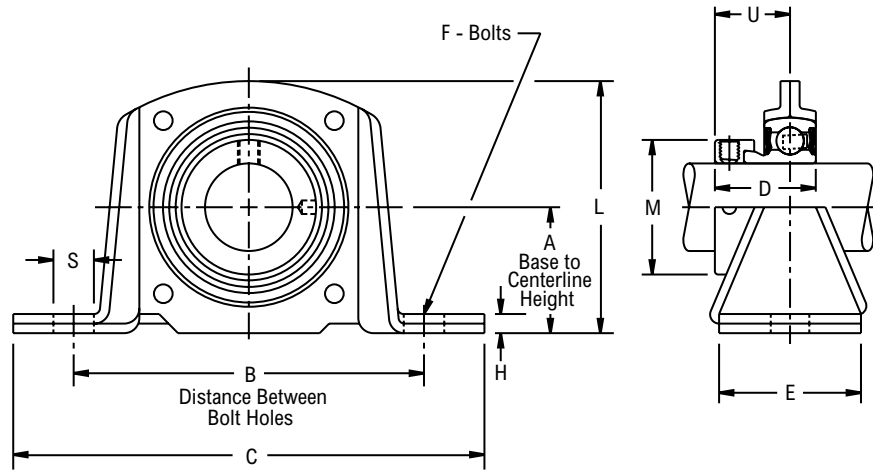
Note: Dimensions subject to change. Certified dimensions of ordered material furnished on request.



Photo Shows a 2-Bolt Ball Bearing Pillow Block Unit with Stamped Steel Housing

Product Features

- Formed steel housing
- Eccentric cam locking device
- Alignable & non-relubricatable
- See Features and Benefits for additional info on pages 286 - 287.



Bearing Dimensions

Size Code	Shaft Diameter	Part Number	Radial Load Rating	A Base to Centerline Height	B Distance Between Bolt Holes	C	D	E	F Bolts	H	L	M	S	U	Approx. Weight
203	1/2	PSW2B08E ▲	600	1 3/16	3 1/2	4 5/8	1 1/8	1 1/16	3/8	7/32	2 11/32	1 1/8	33/64	7/8	0.70
	5/8	PSW210E ▲													
204	3/4	PSW212E ▲	700	1 5/16	3 7/8	5 1/8	1 7/32	1 1/8	3/8	7/32	2 5/8	1 5/16	9/16	59/64	0.90
205	7/8	PSW214E ▲	800	1 7/16	4 1/16	5 3/8	1 7/32	1 7/32	3/8	7/32	2 55/64	1 1/2	1/2	59/64	1.10
	15/16	PSW215E ▲													
	1	PSW216E ▲													
206	1 1/8	PSW218E ▲	985	1 11/16	4 49/64	6 5/16	1 13/32	1 7/16	1/2	5/16	3 5/16	1 3/4	49/64	1 3/64	1.70
	1 3/16	PSW219E ▲													
	1 1/4	PSW2E20E ▲													
207	1 1/4	PSW220E ▲	1,300	1 7/8	5 5/64	6 15/16	1 17/32	1 5/8	1/2	5/16	3 3/4	2 3/16	49/64	1 5/32	2.40
	1 3/8	PSW222E ▲													
	1 7/16	PSW223E ▲													

Additional Notes

- Please call 1-866-REXNORD for availability
- ▲ E lip seals standard
- For the Selection Guide, Load Ratings and Speed Limits, see the Link-Belt 200 Series Ball Bearing Engineering section on pages 290 - 298.
- Note: Dimensions subject to change. Certified dimensions of ordered material furnished on request.

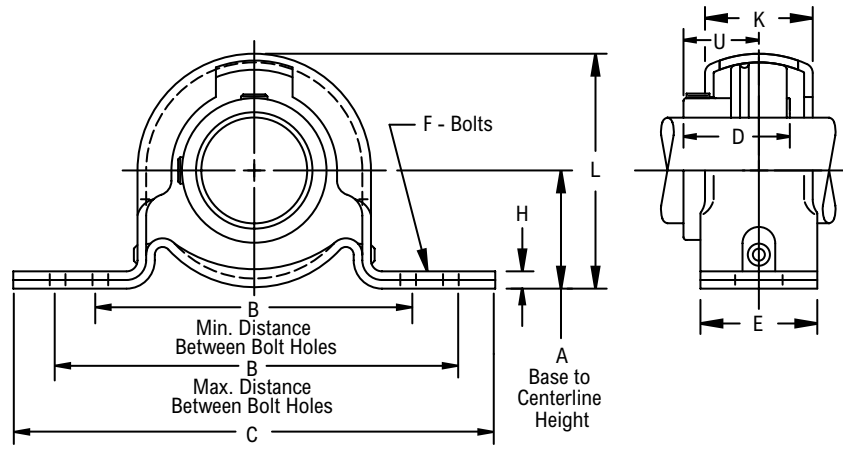
PSS200



Photo Shows a 2-Bolt Ball Bearing Pillow Block Unit with Stamped Steel Housing

Product Features

- Formed steel housing
- Broad range of sealing options
- Spring locking setscrew mount
- Alignable & non-relubricatable
- See Features and Benefits for additional info on pages 286 - 287.



Bearing Dimensions

Size Code	Shaft Diameter	Part Number	A Base to Centerline Height	B Distance Between Bolt Holes		C	D	E	F Bolts	H	K	L	U	Radial Load Rating	Approx. Weight
				Min	Max										
203	1/2	PSS2B08E♦♦ □Δ	7/8	2 1/2	2 7/8	3 5/8	63/64	1	5/16	3/4	13/16	1 3/4	41/64	300	0.50
	5/8	PSS210E♦♦ □Δ													0.46
	11/16	PSS211E♦♦ □Δ													0.44
204	3/4	PSS212E♦♦ □Δ	1	2 7/8	3 1/8	4 1/8	1 1/8	1	3/8	7/8	59/64	2 1/16	23/32	350	0.63
	20.00	PSS2M20E♦♦ □Δ													25.40
205	7/8	PSS214E♦♦ □Δ	1 1/8	3 3/16	3 9/16	4 1/2	1 11/64	1 1/8	3/8	3/4	1 1/16	2 7/32	3/4	400	0.81
	15/16	PSS215E♦♦ □Δ													0.78
	1	PSS216E♦♦ □Δ													0.75
	25.00	PSS2M25E♦♦ □Δ													28.58
206	1 1/8	PSS218E♦♦ □Δ	1 5/16	3 9/16	3 15/16	4 7/8	1 11/32	1 1/8	3/8	7/8	1 3/16	2 5/8	7/8	600	1.19
	1 3/16	PSS219E♦♦ □Δ													1.14
	1 1/4	PSS2E20E♦♦ □Δ													1.11
	30.00	PSS2M30E♦♦ □Δ													33.32
207	1 1/4	PSS220E♦♦ □Δ	1 9/16	3 15/16	4 7/16	5 3/4	1 9/16	1 1/4	1/2	1	1 3/16	3 1/8	1	800	1.65
	1 3/8	PSS222E♦♦ □Δ													1.55
	1 7/16	PSS223E♦♦ □Δ													1.50

Additional Notes

- Please call 1-866-REXNORD for availability
- Lubrication fitting tap size: for size codes 203 thru 205, 1/4-28 UNF; for all other size codes, 1/8 in PT
- Base to centerline tolerance, +/- .005 in (+/- 0.13 mm)
- Lip seals standard
- ♦ Available with E1 viton seals

Available with free running style seals, add suffix ♦♦, FF, □ or HFF or Δ MHFF
 For the Selection Guide, Load Ratings and Speed Limits, see the Link-Belt 200 Series Ball Bearing Engineering section on pages 290 - 298.
 Note: Dimensions subject to change. Certified dimensions of ordered material furnished on request.

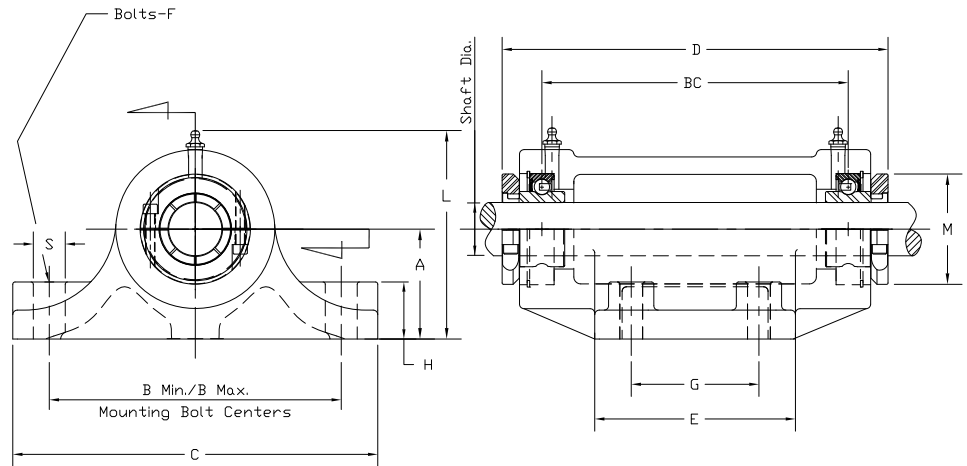
PPCL200

Interchange: F&BDL



Product Features

- Corrosion-resistant powder coating
- Cast iron housing
- Broad range of sealing options
- Wide inner ring for increased shaft stability
- Centrik-Lok CL shaft locking device
- Fan and Blower Interchange
- See Features and Benefits for additional info on pages 286 - 287.



Bearing Dimensions

Size Code	Shaft Diameter	Part Number	A Base to Centerline Height	B Distance Between Bolt Holes		BC	C	D	E	F	G	H	L	M	S	Approx. Weight
				Min	Max											
205	15/16	PPCL215N*■Δ	2 1/2	6 1/16	6 7/16	6 17/64	7 3/4	8	4 1/4	3/8	2 3/4	7/8	4 5/8	2 13/64	5/8	16
206	1 3/16	PPCL219N*■Δ	2 1/2	6 1/16	6 7/16	6 3/32	7 3/4	7 7/8	4 1/4	3/8	2 3/4	7/8	4 5/8	2 19/32	5/8	16
207	1 7/16	PPCL223N*■Δ	3	7 3/4	8 1/4	8 21/32	10	10 11/16	5 1/2	1/2	3 1/2	1	5 11/16	3 3/64	7/8	36
209	1 11/16	PPCL227N*■Δ	3	7 3/4	8 1/4	8 33/64	10	10 59/64	5 1/2	1/2	3 1/2	1	5 11/16	3 3/8	7/8	36
210	1 15/16	PPCL231N*■Δ	3 1/2	9 1/8	9 7/8	11 11/32	12	13 61/64	7	5/8	4 1/2	1 1/4	6 25/64	3 3/4	1 1/8	60
211	2 3/16	PPCL235N*■Δ	3 1/2	9 1/8	9 7/8	11 11/32	12	14	7	5/8	4 1/2	1 1/4	6 25/64	4 5/64	1 1/8	60
212	2 7/16	PPCL239N*■Δ	3 1/2	9 1/8	9 7/8	11 3/8	12	14 35/64	7	5/8	4 1/2	1 1/4	6 19/32	4 9/32	1 1/8	65

Additional Notes

- Please call 1-866-REXNORD for availability
- Lubrication fitting tap size: 1/8 in PT
- Base to centerline tolerance, +.000 in/-0.010 in
- Insert bearing part numbers CLB200XNL, where 00 should be replaced by the shaft size in the part number
- * N lip seals standard

- Available with H labyrinth seals
- Δ Available with E3 triple lip seals
- For the Selection Guide, Load Ratings and Speed Limits, see the Link-Belt 200 Series Ball Bearing Engineering section on pages 290 - 298.
- Note: Dimensions subject to change. Certified dimensions of ordered material furnished on request.

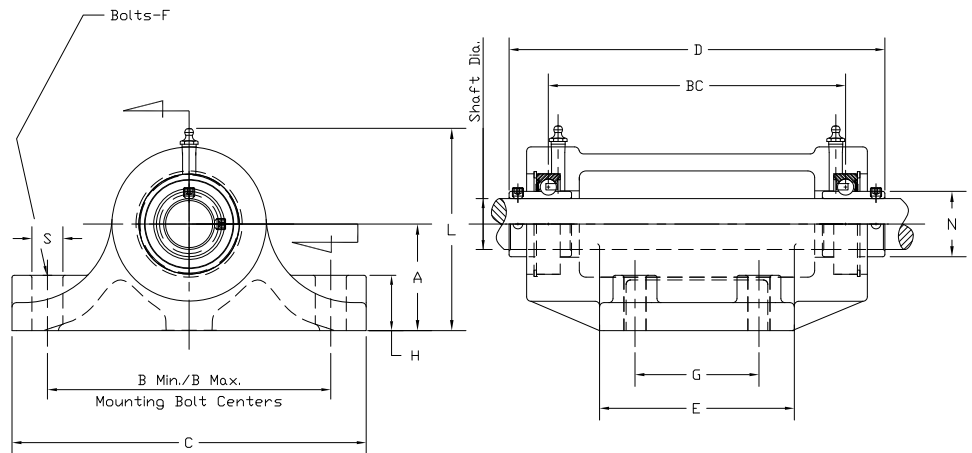
PPU200

Interchange: F&BCC, DRNR



Product Features

- Corrosion-resistant powder coating
- Cast iron housing
- Broad range of sealing options
- Wide inner ring for increased shaft stability
- Spring locking setscrew mount
- Fan and Blower Interchange
- See Features and Benefits for additional info on pages 286 - 287.



Bearing Dimensions

Size Code	Shaft Diameter	Part Number	A Base to Centerline Height	B Distance Between Bolt Holes		BC	C	D	E	F	G	H	L	N	S	Approx. Weight
				Min	Max											
205	15/16	PPU215N* \blacksquare Δ	2 1/2	6 1/16	6 7/16	6 17/64	7 3/4	7 7/8	4 1/4	3/8	2 3/4	7/8	4 5/8	1.313	5/8	16
206	1 3/16	PPU219N* \blacksquare Δ	2 1/2	6 1/16	6 7/16	6 3/32	7 3/4	8	4 1/4	3/8	2 3/4	7/8	4 5/8	1.587	5/8	16
207	1 7/16	PPU223N* \blacksquare Δ	3	7 3/4	8 1/4	8 21/32	10	10 7/8	5 1/2	1/2	3 1/2	1	5 11/16	1.847	7/8	36
209	1 11/16	PPU227N* \blacksquare Δ	3	7 3/4	8 1/4	8 33/64	10	11	5 1/2	1/2	3 1/2	1	5 11/16	2.281	7/8	36
210	1 15/16	PPU231N* \blacksquare Δ	3 1/2	9 1/8	9 7/8	11 11/32	12	13 7/8	7	5/8	4 1/2	1 1/4	6 25/64	2.475	1 1/8	60
211	2 3/16	PPU235N* \blacksquare Δ	3 1/2	9 1/8	9 7/8	11 11/32	12	14 5/32	7	5/8	4 1/2	1 1/4	6 25/64	2.749	1 1/8	60
212	2 7/16	PPU239N* \blacksquare Δ	3 1/2	9 1/8	9 7/8	11 3/8	12	14 1/2	7	5/8	4 1/2	1 1/4	6 19/32	3.012	1 1/8	65

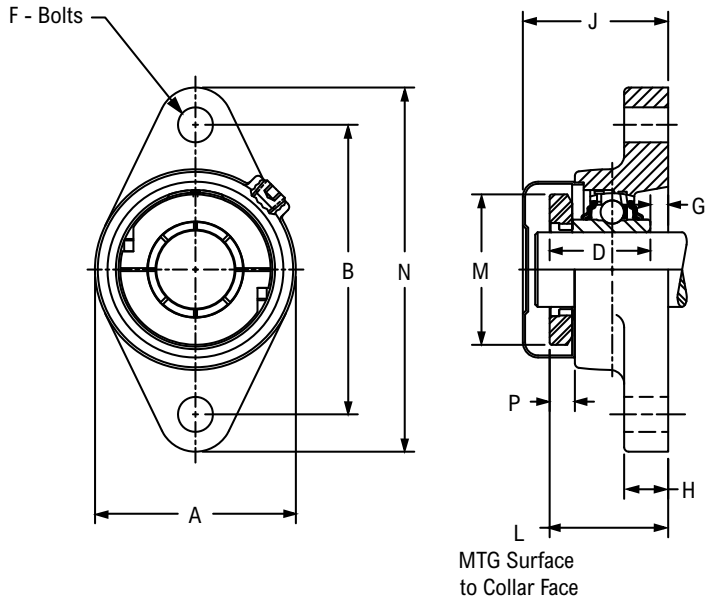
Additional Notes

- Please call 1-866-REXNORD for availability
- Lubrication fitting tap size 1/8 in PT
- Base to centerline tolerance, +.000 in/-0.010 in
- Insert bearing part numbers UB200XNL, where 00 should be replaced by the shaft size in the part number
- *N lip seals standard

- \blacksquare Available with H labyrinth seals
- Δ Available with E3 triple lip seals
- For the Selection Guide, Load Ratings and Speed Limits, see the Link-Belt 200 Series Ball Bearing Engineering section on pages 290 - 298.
- Note: Dimensions subject to change. Certified dimensions of ordered material furnished on request.

FX3CL200

Interchange: F2BDL, GRFT200, SFT-T



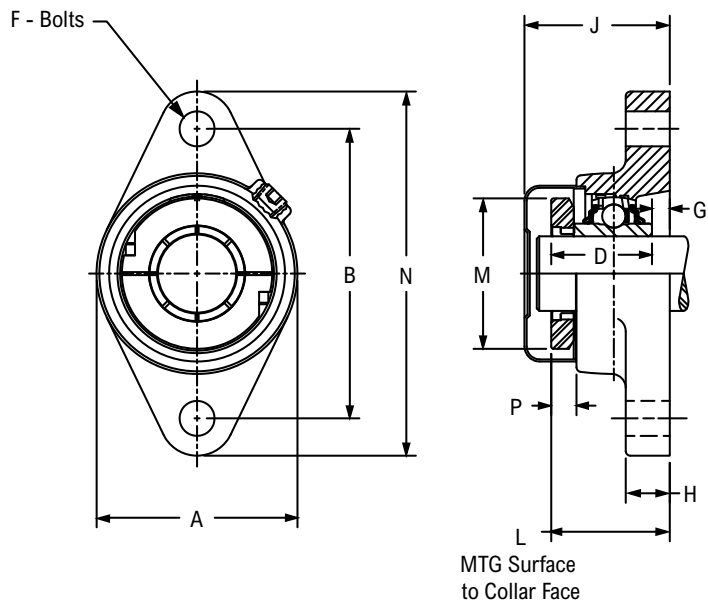
Product Features

- Corrosion-resistant powder coating
- Cast iron housing
- Broad range of sealing options
- Wide inner ring for increased shaft stability
- Alignable & relubricatable
- See Features and Benefits for additional info on pages 286 - 287.

Bearing Dimensions

Size Code	Shaft Diameter	Part Number	B Distance Between Bolt Holes	L Mounting Surface to Collar Face	A	D	F Bolts	G	H	J	M	N	P	Approx. Weight
203	1/2	FX3CL2B08N* ■	3	1 1/4	2 1/8	1 3/32	3/8	5/32	1/2	1 25/32	1 5/8	3 7/8	1/4	0.90
	5/8	FX3CL210N* ■												
	1 1/16	FX3CL211N* ■												
204	3/4	FX3CL212N* ■	3 17/32	1 9/16	2 7/16	1 11/32	3/8	13/64	9/16	2 1/16	1 59/64	4 13/32	3/8	1.20
	20.00	FX3CL2M20N* ■												
205	7/8	FX3CL214N* ■	3 57/64	1 17/32	2 11/16	1 3/8	7/16	3/16	19/32	2 1/16	2 5/64	4 29/32	3/8	1.60
	15/16	FX3CL215N* ▲												
	1	FX3CL216N* ▲												
	25.00	FX3CL2M25N* ▲												
206	1	FX3CL2B16N* ▲	4 19/32	1 47/64	3 3/16	1 9/16	7/16	11/64	19/32	2 1/4	2 15/32	5 19/32	27/64	2.40
	1 1/8	FX3CL218N* ▲												
	1 3/16	FX3CL219N* ▲												
	1 1/4	FX3CL2E20N* ▲												
30.00	FX3CL2M30N* ▲	116.68	43.90	81.00	39.62	10.00	4.40	15.10	57.20	62.48	142.10	10.72	1.08	
207	1 3/16	FX3CL2B19N* ▲	5 1/8	1 29/32	3 5/8	1 3/4	1/2	5/32	5/8	2 25/64	2 7/8	6 1/8	1/2	3.00
	1 1/4	FX3CL220N* ▲												
	1 3/8	FX3CL222N* ▲												
	1 7/16	FX3CL223N* ▲												
35.00	FX3CL2M35N* ▲	130.18	48.30	92.10	44.45	12.00	4.00	15.90	60.70	73.15	155.60	12.70	1.35	
208	1 7/16	FX3CL2B23N* ▲	5 21/32	2 1/8	4	1 15/16	1/2	11/64	5/8	2 37/64	3 3/64	6 25/32	35/64	4.20
	1 1/2	FX3CL224N* ▲												
	1 5/8	FX3CL2E26N* ▲												
40.00	FX3CL2M40N* ▲	143.67	53.90	101.60	49.28	12.00	4.40	15.90	65.50	77.47	172.20	13.72	1.90	
209	1 1/2	FX3CL2B24N* ▲	5 27/32	2 1/8	4 1/4	1 61/64	1/2	7/64	5/8	2 19/32	3 17/64	7 3/32	33/64	5.10
	1 5/8	FX3CL226N* ▲												
	1 11/16	FX3CL227N* ▲												
	1 3/4	FX3CL228N* ▲												
45.00	FX3CL2M45N* ▲	148.30	53.90	108.00	49.53	12.00	2.80	15.90	65.80	82.80	180.20	13.21	2.30	
210	1 11/16	FX3CL2B27N* ▲	6 3/16	2 7/16	4 9/16	2 5/64	9/16	19/64	3/4	2 59/64	3 5/8	7 7/16	39/64	6.30
	1 3/4	FX3CL2B28N* ▲												
	1 7/8	FX3CL230N* ▲												
	1 15/16	FX3CL231N* ▲												

Continued...



Continued...

Bearing Dimensions

Size Code	Shaft Diameter	Part Number	B Distance Between Bolt Holes	L Mounting Surface to Collar Face	A	D	F Bolts	G	H	J	M	N	P	Approx. Weight
210	2	FX3CL2E32N* Δ ■	6 ³ / ₁₆	2 ⁷ / ₁₆	4 ⁹ / ₁₆	2 ⁵ / ₆₄	⁹ / ₁₆	¹⁹ / ₆₄	³ / ₄	2 ⁵⁹ / ₆₄	3 ⁵ / ₈	7 ⁷ / ₁₆	³⁹ / ₆₄	6.30
	50.00	FX3CL2M50N* Δ ■	157.16	62.00	115.90	52.58	14.00	7.50	19.00	75.00	92.20	188.90	15.24	2.84
211	1 ¹⁵ / ₁₆	FX3CL2B31N* Δ ■	7 ¹ / ₄	2 ²¹ / ₃₂	5	2 ¹⁵ / ₆₄	⁵ / ₈	¹³ / ₃₂	¹⁵ / ₁₆	3 ¹¹ / ₆₄	3 ²⁹ / ₃₂	8 ¹ / ₂	²¹ / ₃₂	7.40
	2	FX3CL232N* Δ ■												
	2 ³ / ₁₆	FX3CL235N* Δ ■												
	2 ¹ / ₄	FX3CL2E36N* Δ ■												
55.00	FX3CL2M55N* Δ ■	184.15	67.30	127.00	56.90	16.00	10.30	20.60	80.50	99.31	215.90	16.51	3.33	

Additional Notes

- Please call 1-866-REXNORD for availability
- Lubrication fitting tap size 1/8 in PT
- * N lip seals standard
- Available with H labyrinth seals
- Δ Available with E3 triple lip seals
- Nickel plated housings available, add suffix K75

For the Selection Guide, Load Ratings and Speed Limits, see the Link-Belt 200 Series Ball Bearing Engineering section on pages 290 - 298.

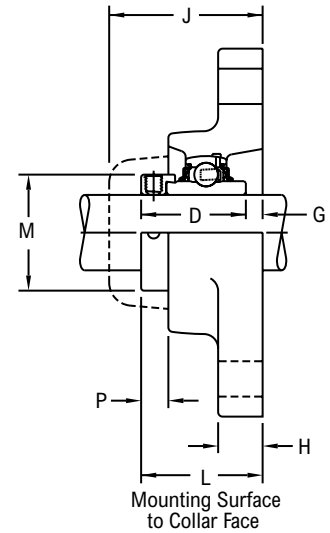
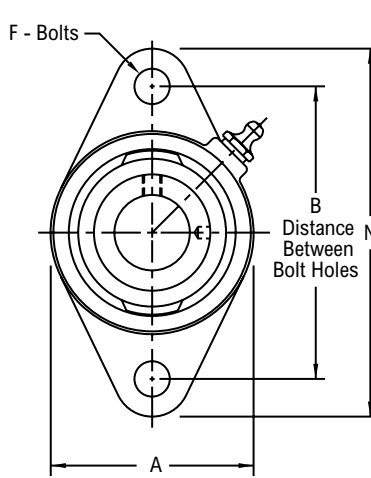
Note: Dimensions subject to change. Certified dimensions of ordered material furnished on request.

FX3Y200

Interchange: F2BSXR, FYT-WF, HCFTS200, RCJT



Photo Shows a 2-Bolt Ball Bearing Flanged Unit



Product Features

- Corrosion-resistant powder coating
- Cast iron housing
- Broad range of sealing options
- Wide inner ring for increased shaft stability
- Eccentric cam locking device
- Alignable & relubricatable
- See Features and Benefits for additional info on pages 286 - 287.

Bearing Dimensions

Size Code	Shaft Diameter	Part Number	B Distance Between Bolt Holes	L Mounting Surface to Collar Face	A	D	F Bolts	G	H	J	M	N	P	Approx. Weight
203	1/2	FX3Y2B08N*■	3	1 17/32	2 1/8	1 15/32	3/8	1/16	1/2	1 25/32	1 1/8	3 7/8	33/64	1.00
	5/8	FX3Y210N*■												
	11/16	FX3Y211N*■												
204	3/4	FX3Y212N*■	3 17/32	1 51/64	2 7/16	1 23/32	3/8	1/16	9/16	2 1/64	1 5/16	4 13/32	37/64	1.30
	7/8	FX3Y214N*△												
205	15/16	FX3Y215N*△	3 57/64	1 13/16	2 11/16	1 3/4	7/16	1/16	19/32	2	1 1/2	4 29/32	35/64	1.70
	1	FX3Y216N*△												
206	1 1/8	FX3Y218N*△	4 19/32	1 31/32	3 3/16	1 29/32	7/16	1/16	19/32	2 15/64	1 3/4	5 19/32	21/32	2.50
	1 3/16	FX3Y219N*△												
	1 1/4	FX3Y2E20N*■												
207	1 1/4	FX3Y220N*△	5 1/8	2 5/64	3 5/8	2 1/64	1/2	1/16	5/8	2 23/64	2 3/16	6 1/8	11/16	3.30
	1 3/8	FX3Y222N*△												
	1 7/16	FX3Y223N*△												
208	1 1/2	FX3Y224N*△	5 21/32	2 9/32	4	2 7/32	1/2	1/16	5/8	2 35/64	2 3/8	6 25/32	45/64	4.50
	1 5/8	FX3Y226N*△												
209	1 11/16	FX3Y227N*△	5 27/32	2 9/32	4 1/4	2 7/32	1/2	1/16	5/8	2 9/16	2 1/2	7 3/32	11/16	5.40
	1 3/4	FX3Y228N*△												
	1 15/16	FX3Y231N*△												
210	2	FX3Y2E32N*■	6 3/16	2 5/8	4 9/16	2 15/32	9/16	5/32	3/4	2 57/64	2 3/4	7 7/16	25/32	6.60
	2	FX3Y232N*△												
211	2 1/16	FX3Y235N*△	7 1/4	2 31/32	5	2 13/16	5/8	5/32	13/16	3 1/4	3	8 1/2	31/32	8.00
	2 3/16	FX3Y235N*△												

Additional Notes

- Please call 1-866-REXNORD for availability
- Lubrication fitting tap size: for size code 203, 1/4 in-28 UNF: for all other size codes, 1/8 in PT
- * N lip seals standard
- Available with H labyrinth seals
- △ Available with E3 triple lip seals

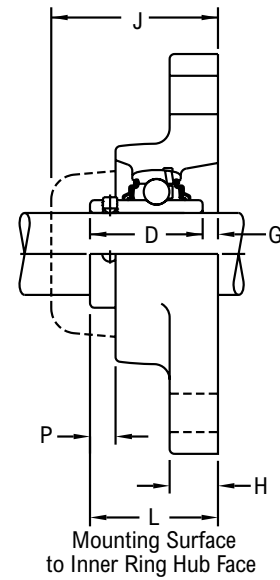
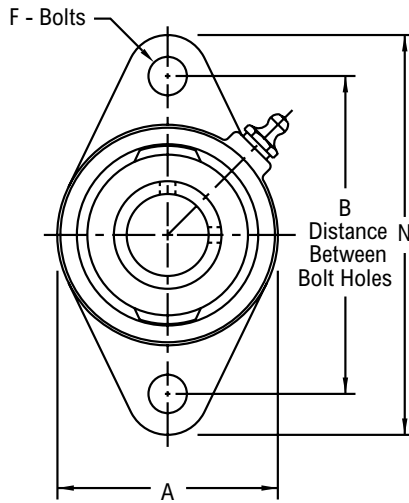
Nickel plated housings available, add suffix K75
 For the Selection Guide, Load Ratings and Speed Limits, see the Link-Belt 200 Series Ball Bearing Engineering section on pages 290 - 298.
 Note: Dimensions subject to change. Certified dimensions of ordered material furnished on request.

FX3U200

Interchange: F2BSC, FYT-TF, UCFT200, SFT, YCJT



Photo Shows a 2-Bolt Ball Bearing Flanged Unit



Product Features

- Corrosion-resistant powder coating
- Cast iron housing
- Broad range of sealing options
- Wide inner ring for increased shaft stability
- Spring locking setscrew mount
- Alignable & relubricatable
- See Features and Benefits for additional info on pages 286 - 287.

Size Code	Shaft Diameter	Part Number	B Distance Between Bolt Holes	L Mounting Surface to Inner Ring Hub Face	A	D	F Bolts	G	H	J	N	P	Approx. Weight
203	1/2	FX3U2B08N*■	3	1 1/4	2 1/8	1 3/32	3/8	5/32	1/2	1 25/32	3 7/8	1/4	0.90
	5/8	FX3U210N*■											
	11/16	FX3U211N*■											
	17.00	FX3U2M17N*■	76.20	31.80	54.00	27.78	10.00	4.00	12.70	45.20	98.40	6.40	0.41
204	3/4	FX3U212N*■	3 17/32	1 31/64	2 7/16	1 9/32	3/8	13/64	9/16	2 1/64	4 13/32	9/32	1.20
	20.00	FX3U2M20N*■	89.69	37.70	61.90	32.54	10.00	5.20	14.30	51.20	111.90	7.10	0.54
205	7/8	FX3U214N*△	3 57/64	1 35/64	2 11/16	1 23/64	7/16	3/16	19/32	2	4 29/32	19/64	1.60
	15/16	FX3U215N*△											
	1	FX3U216N*△											
	25.00	FX3U2M25N*△											
206	1 1/8	FX3U218N*△	4 19/32	1 47/64	3 3/16	1 9/16	7/16	11/64	19/32	2 15/64	5 19/32	27/64	2.40
	1 3/16	FX3U219N*△											
	1 1/4	FX3U2E20N*△											
	30.00	FX3U2M30N*△											
207	1 1/4	FX3U220N*△	5 1/8	1 59/64	3 5/8	1 49/64	1/2	5/32	5/8	2 23/64	6 1/8	33/64	3.00
	1 3/8	FX3U222N*△											
	1 7/16	FX3U223N*△											
	35.00	FX3U2M35N*△											
208	1 1/2	FX3U224N*△	5 21/32	2 5/64	4	1 29/32	1/2	11/64	5/8	2 35/64	6 25/32	1/2	4.20
	40.00	FX3U2M40N*△	143.67	52.80	101.60	48.42	12.00	4.40	15.90	64.70	172.20	12.70	1.90
209	1 5/8	FX3U226N*△	5 27/32	2 9/64	4 1/4	2 1/32	1/2	7/64	5/8	2 9/16	7 3/32	35/64	5.10
	1 11/16	FX3U227N*△											
	1 3/4	FX3U228N*△											
	45.00	FX3U2M45N*△											
210	1 15/16	FX3U231N*△	6 3/16	2 25/64	4 9/16	2 3/32	9/16	19/64	3/4	2 57/64	7 7/16	9/16	6.30
	2	FX3U2E32N*△											
	50.00	FX3U2M50N*△											
211	2	FX3U232N*△	7 1/4	2 21/32	5	2 1/4	5/8	13/32	13/16	3 1/4	8 1/2	21/32	7.40
	2 3/16	FX3U235N*△											
	55.00	FX3U2M55N*△											

Additional Notes

- Please call 1-866-REXNORD for availability
- Lubrication fitting tap size: for size code 203, 1/4 in-28 UNF; for all other size codes, 1/8 in PT
- * N lip seals standard
- Available with H labyrinth seals
- △ Available with E3 triple lip seals

Nickel plated housings available, add suffix K75

For the Selection Guide, Load Ratings and Speed Limits, see the Link-Belt 200 Series Ball Bearing Engineering section on pages 290 - 298.

Note: Dimensions subject to change. Certified dimensions of ordered material furnished on request.

FX3W200

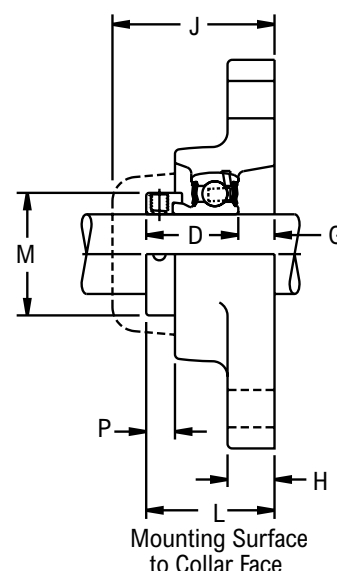
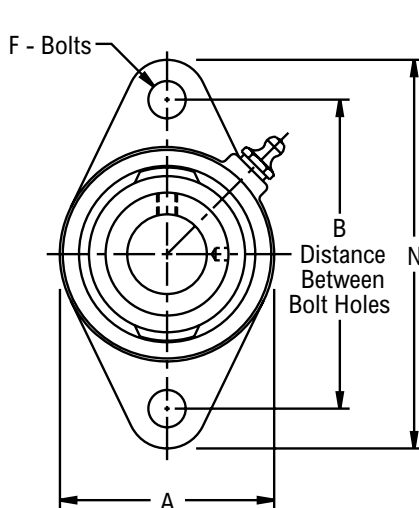
Interchange: F2BSXV, FYT-FM, FHFT200-G, VF2E100, VCJT



Photo Shows a 2-Bolt Ball Bearing Flanged Unit

Product Features

- Corrosion-resistant powder coating
- Cast iron housing
- Eccentric cam locking device
- Alignable & relubricatable
- See Features and Benefits for additional info on pages 286 - 287.



Bearing Dimensions

Size Code	Shaft Diameter	Part Number	B Distance Between Bolt Holes	L Mounting Surface to Collar Face	A	D	F Bolts	G	H	J	M	N	P	Approx. Weight
203	1/2	FX3W2B08E▲	3	1 31/64	2 1/8	1 1/8	3/8	23/64	1/2	1 25/32	1 1/8	3 7/8	15/32	0.60
	5/8	FX3W210E▲												
204	3/4	FX3W212E▲	3 17/32	1 21/32	2 7/16	1 7/32	3/8	7/16	9/16	2 1/64	1 9/16	4 13/32	29/64	1.00
205	7/8	FX3W214E▲	3 57/64	1 43/64	2 11/16	1 7/32	7/16	29/64	19/32	2	1 1/2	4 29/32	27/64	1.40
	15/16	FX3W215E▲												
	1	FX3W216E▲												
206	1 1/8	FX3W218E▲	4 19/32	1 53/64	3 3/16	1 13/32	7/16	27/64	19/32	2 15/64	1 3/4	5 19/32	33/64	2.10
	1 3/16	FX3W219E▲												
	1 1/4	FX3W220E▲												
207	1 1/4	FX3W220E▲	5 1/8	1 31/32	3 5/8	1 17/32	1/2	7/16	5/8	2 23/64	2 3/16	6 1/8	9/16	3.00
	1 3/8	FX3W222E▲												
	1 7/16	FX3W223E▲												
208	1 1/2	FX3W224E▲	5 21/32	2 3/16	4	1 23/32	1/2	15/32	5/8	2 35/64	2 3/8	6 25/32	39/64	4.00
209	1 5/8	FX3W226E▲	5 27/32	2 3/16	4 1/4	1 23/32	1/2	15/32	5/8	2 9/16	2 1/2	7 3/32	19/32	4.70
	1 11/16	FX3W227E▲												
	1 3/4	FX3W228E▲												
210	1 15/16	FX3W231E▲	6 3/16	2 13/32	4 9/16	1 23/32	9/16	11/16	3/4	2 57/64	2 3/4	7 7/16	9/16	5.70
	2	FX3W232E▲												

Additional Notes

- Please call 1-866-REXNORD for availability
- Lubrication fitting tap size: for size code 203, 1/4 in-28 UNF: for all other size codes, 1/8 in PT
- ▲ E lip seals standard
- Nickel plated housings available, add suffix K75

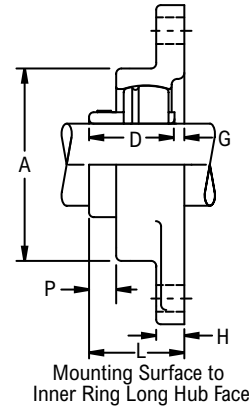
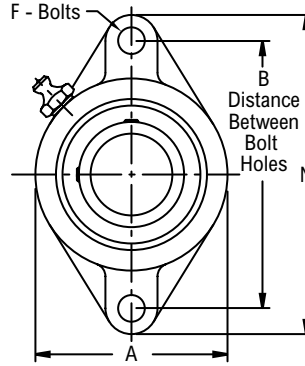
For the Selection Guide, Load Ratings and Speed Limits, see the Link-Belt 200 Series Ball Bearing Engineering section on pages 290 - 298.
Note: Dimensions subject to change. Certified dimensions of ordered material furnished on request.

FX3S200

Interchange: F2BVSC, FYT-RM, FHSFT200-G, VF2S100, SCJT



Photo Shows a 2-Bolt Ball Bearing Flanged Unit



Product Features

- Corrosion-resistant powder coating
- Cast iron housing
- Broad range of sealing options
- Spring locking setscrew mount
- Alignable & relubricatable
- See Features and Benefits for additional info on pages 286 - 287.

Bearing Dimensions

Size Code	Shaft Diameter	Part Number	B Distance Between Bolt Holes	L Mounting Surface to Inner Ring Long Hub Face	A	D	F Bolts	G	H	N	P	Approx. Weight
203	1/2	FX3S2B08E♦♦ □Δ	3	1 1/8	2 5/16	63/64	3/8	9/64	3/8	3 7/8	5/16	0.81
	5/8	FX3S210E♦♦ □Δ										0.77
	11/16	FX3S211E♦♦ □Δ										0.75
204	3/4	FX3S212E♦♦ □Δ	3 17/32	1 9/32	2 3/8	1 1/8	3/8	9/64	7/16	4 13/32	13/32	0.91
	20.00	FX3S2M20E♦♦ □Δ	89.69	32.20	60.30	28.58	10.00	3.60	11.10	111.90	10.30	0.40
205	7/8	FX3S214E♦♦ □Δ	3 57/64	1 5/16	2 3/4	1 11/64	7/16	1/8	1/2	4 7/8	7/16	1.32
	15/16	FX3S215E♦♦ □Δ										1.29
	1	FX3S216E♦♦ □Δ										1.26
	25.00	FX3S2M25E♦♦ □Δ										98.82
206	1 1/8	FX3S218E♦♦ □Δ	4 19/32	1 1/2	3 3/16	1 11/32	7/16	9/64	17/32	5 9/16	9/16	1.79
	1 3/16	FX3S219E♦♦ □Δ										1.75
	1 1/4	FX3S2E20E♦♦ □Δ										1.71
	30.00	FX3S2M30E♦♦ □Δ										116.68
207	1 1/4	FX3S220E♦♦ □Δ	5 1/8	1 23/32	3 11/16	1 9/16	1/2	9/64	9/16	6 1/8	21/32	2.69
	1 3/8	FX3S222E♦♦ □Δ										2.59
	1 7/16	FX3S223E♦♦ □Δ										2.54
	35.00	FX3S2M35E♦♦ □Δ										130.18
208	1 1/2	FX3S224E♦♦ □Δ	5 21/32	1 13/16	4 1/8	1 21/32	1/2	5/32	9/16	6 3/4	21/32	3.47
	1 5/8	FX3S2E26E♦♦ □Δ										3.33
	40.00	FX3S2M40E♦♦ □Δ										143.67
209	1 5/8	FX3S226E♦♦ □Δ	5 27/32	1 29/32	4 3/8	1 49/64	9/16	1/8	9/16	7 1/16	23/32	3.46
	1 11/16	FX3S227E♦♦ □Δ										3.39
	1 3/4	FX3S228E♦♦ □Δ										3.32
	1 7/8	FX3S230E♦♦ □Δ										4.43
210	1 15/16	FX3S231E♦♦ □Δ	6 3/16	1 29/32	4 9/16	1 13/16	9/16	7/64	5/8	7 15/32	23/32	4.34
	2	FX3S2E32E♦♦ □Δ										4.25
	2	FX3S232E♦♦ □Δ										6.04
211	2	FX3S235E♦♦ □Δ	7 1/4	2	5	1 13/16	5/8	11/64	23/32	8 1/2	11/16	5.74
	2 1/4	FX3S2E36E♦♦ □Δ										5.64

Additional Notes

- Please call 1-866-REXNORD for availability
- Lubrication fitting tap size: for size codes 203 thru 205, 1/4-28 UNF; for all other size codes, 1/8 in PT
- Lip seals standard
- ♦ Available with E1 viton seals
- Available with free running style seals, add suffix ♦ FF, □ HFF or Δ MHFF

Nickel plated housings available, add suffix K75

For the Selection Guide, Load Ratings and Speed Limits, see the Link-Belt 200 Series Ball Bearing Engineering section on pages 290 - 298.

Note: Dimensions subject to change. Certified dimensions of ordered material furnished on request.

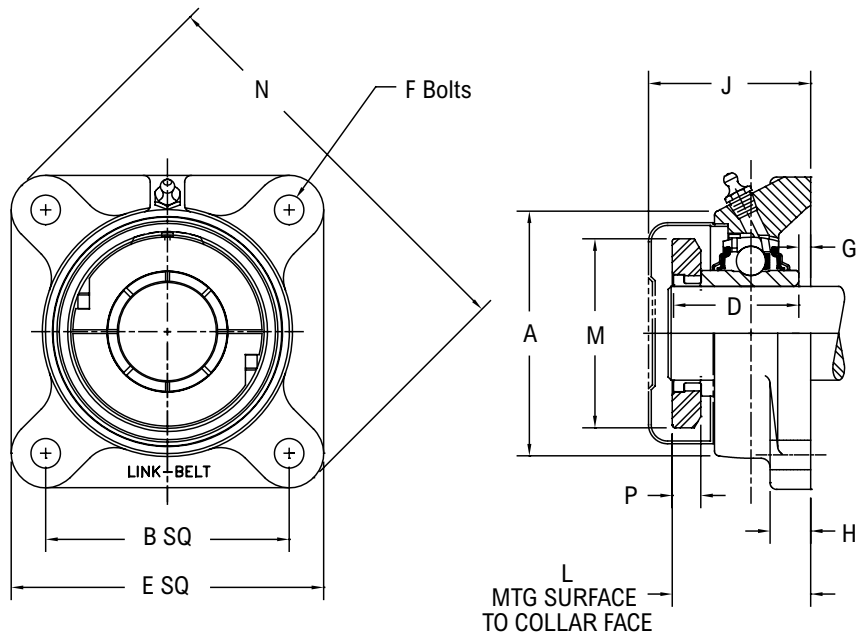
F3CL200

Interchange: F4BDL, GRF200, SF-T



Product Features

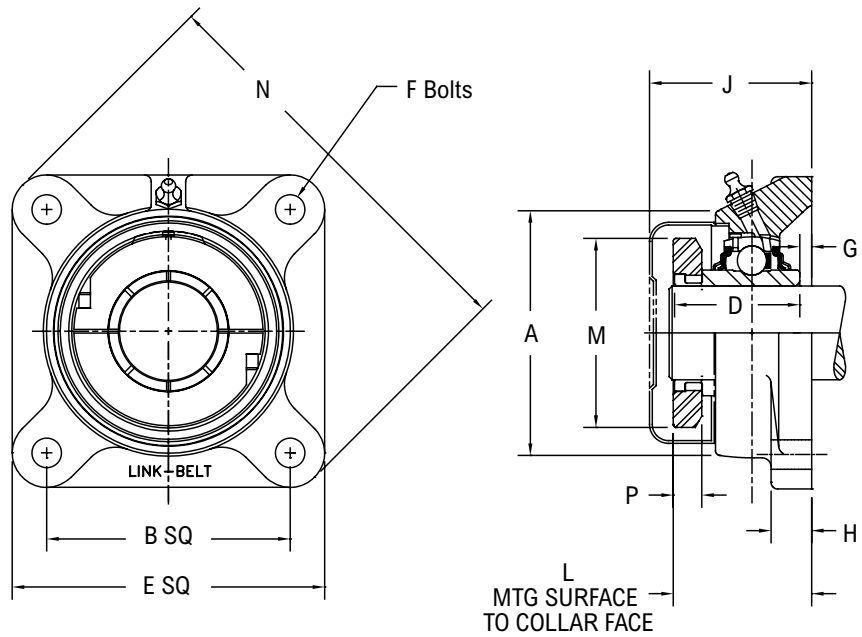
- Corrosion-resistant powder coating
- Cast iron housing
- Broad range of sealing options
- Wide inner ring for increased shaft stability
- Alignable & lubricatable
- See Features and Benefits for additional info on pages 286 - 287.



Bearing Dimensions

Size Code	Shaft Diameter	Part Number	B Distance Between Bolt Holes	L Mounted Surface to Collar Face	A	D	E	F Bolts	G	H	J	M	N	P	Approx. Weight	
204	³ / ₄	F3CL212N* ■	2 ¹ / ₂	1 ⁹ / ₁₆	2 ⁷ / ₁₆	1 ¹¹ / ₃₂	3 ³ / ₈	³ / ₈	¹³ / ₆₄	⁹ / ₁₆	2 ¹ / ₁₆	1 ⁵⁹ / ₆₄	4 ¹³ / ₃₂	³ / ₈	1.50	
	20.00	F3CL2M20N* ■	63.50	39.90	61.90	34.04	85.70	10.00	5.20	14.30	52.30	48.77	111.90	9.53	0.68	
205	⁷ / ₈	F3CL214N* ■	2 ³ / ₄	1 ¹⁷ / ₃₂	2 ¹¹ / ₁₆	1 ³ / ₈	3 ³ / ₄	⁷ / ₁₆	³ / ₁₆	¹⁹ / ₃₂	2 ¹ / ₁₆	2 ⁵ / ₆₄	4 ²⁹ / ₃₂	³ / ₈	1.90	
	¹⁵ / ₁₆	F3CL215N* ■														
	1	F3CL216N* ■	25.00	F3CL2M25N* ■	69.85	38.90	68.30	34.80	95.20	10.00	4.80	15.10	52.30	52.83	124.60	9.53
206	1	F3CL2B16N* ■	3 ¹ / ₄	1 ⁴⁷ / ₆₄	3 ³ / ₁₆	1 ⁹ / ₁₆	4 ¹ / ₄	⁷ / ₁₆	¹¹ / ₆₄	¹⁹ / ₃₂	2 ¹ / ₄	2 ¹⁵ / ₃₂	5 ¹⁹ / ₃₂	²⁷ / ₆₄	3.10	
	¹ / ₈	F3CL218N* ■														
	¹ / ₁₆	F3CL219N* ■														
	¹ / ₄	F3CL2E20N* ■														
30.00	F3CL2M30N* ■	82.55	43.90	81.00	39.62	108.00	10.00	4.40	15.10	57.20	62.48	142.10	10.72	1.40		
207	¹ / ₁₆	F3CL2B19N* ■	3 ⁵ / ₈	1 ²⁹ / ₃₂	3 ⁵ / ₈	1 ³ / ₄	4 ⁵ / ₈	¹ / ₂	⁵ / ₃₂	⁵ / ₈	2 ²⁵ / ₆₄	2 ⁷ / ₈	6 ¹ / ₈	¹ / ₂	3.90	
	¹ / ₄	F3CL220N* ■														
	¹ / ₈	F3CL222N* ■														
	¹ / ₁₆	F3CL223N* ■														
35.00	F3CL2M35N* ■	92.08	48.30	92.10	44.45	117.50	12.00	4.00	15.90	60.70	73.15	155.60	12.70	1.75		
208	¹ / ₁₆	F3CL2B23N* ■	4	2 ¹ / ₈	4	1 ¹⁵ / ₁₆	5 ¹ / ₈	¹ / ₂	¹¹ / ₆₄	⁵ / ₈	2 ³⁷ / ₆₄	3 ³ / ₆₄	6 ²⁵ / ₃₂	³⁵ / ₆₄	5.00	
	¹ / ₂	F3CL224N* ■														
	¹ / ₈	F3CL2E26N* ■														
40.00	F3CL2M40N* ■	101.60	53.90	101.60	49.28	130.20	12.00	4.40	15.90	65.50	77.47	172.20	13.72	2.25		
209	¹ / ₂	F3CL2B24N* ■	4 ¹ / ₈	2 ¹ / ₈	4 ¹ / ₄	1 ⁶¹ / ₆₄	5 ³ / ₈	¹ / ₂	⁷ / ₆₄	⁵ / ₈	2 ¹⁹ / ₃₂	3 ¹⁷ / ₆₄	7 ³ / ₃₂	³³ / ₆₄	6.20	
	¹ / ₈	F3CL226N* ■														
	¹ / ₁₆	F3CL227N* ■														
	¹ / ₄	F3CL228N* ■														
45.00	F3CL2M45N* ■	104.78	53.90	108.00	49.53	136.50	12.00	2.80	15.90	65.80	82.80	180.20	13.21	2.80		
210	¹ / ₁₆	F3CL2B27N* ■	4 ³ / ₈	2 ²³ / ₆₄	4 ¹ / ₂	2 ⁵ / ₆₄	5 ⁵ / ₈	¹ / ₂	¹³ / ₆₄	³ / ₄	2 ⁵³ / ₆₄	3 ⁵ / ₈	7 ⁷ / ₁₆	⁵ / ₈	6.90	
	¹ / ₄	F3CL2B28N* ■														
	¹ / ₈	F3CL230N* ■														
	¹ / ₁₆	F3CL231N* ■														
	2	F3CL2E32N* ■														
50.00	F3CL2M50N* ■	111.12	59.70	114.30	52.58	142.90	12.00	5.20	19.00	71.90	92.20	188.90	15.75	3.10		

Continued...



Continued...

Bearing Dimensions

Size Code	Shaft Diameter	Part Number	B Distance Between Bolt Holes	L Mounted Surface to Collar Face	A	D	E	F Bolts	G	H	J	M	N	P	Approx. Weight
211	1 ¹⁵ / ₁₆	F3CL2B31N*Δ	5 ¹ / ₈	2 ⁹ / ₁₆	4 ¹⁵ / ₁₆	2 ¹⁵ / ₆₄	6 ³ / ₈	5/ ₈	5/ ₁₆	29/ ₃₂	3 ⁵ / ₆₄	3 ²⁹ / ₃₂	8 ¹ / ₂	5/ ₈	8.90
	2	F3CL232N*Δ													
	2 ³ / ₁₆	F3CL235N*Δ													
	2 ¹ / ₄	F3CL2E36N*Δ													
55.00	F3CL2M55N*Δ	130.18	65.00	125.40	56.75	161.90	16.00	7.90	23.00	78.20	99.22	215.90	15.75	4.00	
212	2 ³ / ₁₆	F3CL2B35N*Δ	5 ⁵ / ₈	2 ⁵⁶ / ₆₄	5 ³ / ₈	2 ¹⁹ / ₃₂	6 ⁷ / ₈	5/ ₈	11/ ₃₂	15/ ₁₆	3 ²⁹ / ₆₄	4 ³ / ₁₆	9 ⁷ / ₃₂	21/ ₃₂	11.90
	2 ¹ / ₄	F3CL236N*Δ													
	2 ³ / ₈	F3CL238N*Δ													
	2 ⁷ / ₁₆	F3CL239N*Δ													
60.00	F3CL2M60N*Δ	142.88	72.60	136.50	65.88	174.60	16.00	8.70	23.80	85.30	106.36	234.20	16.76	5.35	
213	2 ¹ / ₂	F3CL240N*Δ	5 ⁷ / ₈	2 ²⁷ / ₃₂	5 ⁷ / ₈	2 ³ / ₄	7 ³ / ₈	5/ ₈	3/ ₃₂	3/ ₄	3 ¹³ / ₆₄	4 ⁵¹ / ₆₄	9 ¹³ / ₁₆	5/ ₈	14.40
	2 ¹¹ / ₁₆	F3CL243N*Δ													
	65.00	F3CL2M65N*Δ													
215	2 ³ / ₄	F3CL244N*Δ	6	3	6	2 ⁵⁹ / ₆₄	7 ³ / ₄	3/ ₄	3/ ₃₂	3/ ₄	3 ³⁷ / ₆₄	5 ¹ / ₄	10 ¹ / ₄	11/ ₁₆	17.40
	2 ¹⁵ / ₁₆	F3CL247N*Δ													
	3	F3CL2E48N*Δ													
75.00	F3CL2M75N*Δ	152.40	76.45	152.40	74.22	196.80	20.00	2.40	19.00	90.88	133.35	260.40	17.50	7.85	
217	3 ⁷ / ₁₆	F3CL255N*Δ	6 ³ / ₄	3 ¹¹ / ₁₆	6 ³ / ₄	3 ³⁹ / ₆₄	8 ⁹ / ₁₆	3/ ₄	3/ ₃₂	1	4 ²⁷ / ₆₄	5 ²³ / ₃₂	11 ³ / ₈	3/ ₄	25.70
	3 ¹ / ₂	F3CL2E56N*Δ													
	85.00	F3CL2M85N*Δ													

Additional Notes

Please call 1-866-REXNORD for availability
 Lubrication fitting tap size: for size code 203, 1/4 in-28 UNF; for all other size codes, 1/8 in PT
 * N lip seals standard
 ■ Available with H labyrinth seals
 Δ Available with E3 triple lip seals

Nickel plated housings available, add suffix K75
 For the Selection Guide, Load Ratings and Speed Limits, see the Link-Belt 200 Series Ball Bearing Engineering section on pages 290 - 298.
 Note: Dimensions subject to change. Certified dimensions of ordered material furnished on request.

F3Y200

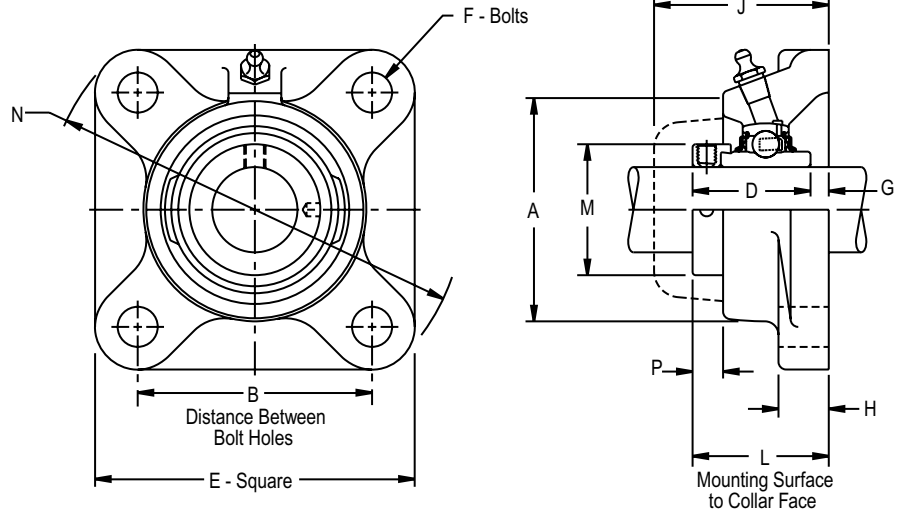
Interchange: F4BSXR, FY-WF, HCFS200, RCJ



Photo Shows a 4-Bolt Ball Bearing Flanged Unit

Product Features

- Corrosion-resistant powder coating
- Cast iron housing
- Broad range of sealing options
- Wide inner ring for increased shaft stability
- Eccentric cam locking device
- Alignable & relubricatable
- See Features and Benefits for additional info on pages 286 - 287.



Bearing Dimensions

Size Code	Shaft Diameter	Part Number	B Distance Between Bolt Holes	L Mounting Surface to Collar Face	A	D	E	F Bolts	G	H	J	M	N	P	Approx. Weight
204	3/4	F3Y212N *■	2 1/2	1 5/64	2 7/16	1 23/32	3 3/8	3/8	1/16	9/16	2 1/64	1 5/16	4 13/32	37/64	1.60
	7/8	F3Y214N *Δ													
205	15/16	F3Y215N *Δ	2 3/4	1 13/16	2 11/16	1 3/4	3 3/4	7/16	1/16	19/32	2	1 1/2	4 29/32	35/64	2.00
	1	F3Y216N *Δ													
206	1 1/8	F3Y218N *Δ	3 1/4	1 31/32	3 3/16	1 29/32	4 1/4	7/16	1/16	19/32	2 15/64	1 3/4	5 19/32	21/32	3.20
	1 3/16	F3Y219N *Δ													
	1 1/4	F3Y220N *Δ													
207	1 1/4	F3Y220N *Δ	3 5/8	2 5/64	3 5/8	2 1/64	4 5/8	1/2	1/16	5/8	2 23/64	2 3/16	6 1/8	11/16	4.20
	1 3/8	F3Y222N *Δ													
	1 7/16	F3Y223N *Δ													
208	1 1/2	F3Y224N *Δ	4	2 9/32	4	2 7/32	5 1/8	1/2	1/16	5/8	2 35/64	2 3/8	6 25/32	45/64	5.30
	1 5/8	F3Y226N *Δ													
209	1 11/16	F3Y227N *Δ	4 1/8	2 9/32	4 1/4	2 7/32	5 3/8	1/2	1/16	5/8	2 9/16	2 1/2	7 3/32	11/16	6.50
	1 3/4	F3Y228N *Δ													
210	1 15/16	F3Y231N *Δ	4 3/8	2 17/32	4 1/2	2 15/32	5 5/8	1/2	1/16	3/4	2 13/16	2 3/4	7 7/16	51/64	7.20
	2	F3Y232N *Δ													
211	2	F3Y232N *Δ	5 1/8	2 7/8	4 15/16	2 13/16	6 3/8	5/8	1/16	29/32	3 11/64	3	8 1/2	15/16	9.50
	2 3/16	F3Y235N *Δ													
212	2 1/4	F3Y236N *Δ	5 5/8	3 1/8	5 3/8	3 1/16	6 7/8	5/8	1/16	15/16	3 25/64	3 5/16	9 7/32	15/16	12.50
	2 3/8	F3Y238N *Δ													
	2 7/16	F3Y239N *Δ													

Additional Notes

- Please call 1-866-REXNORD for availability
- Lubrication fitting tap size: for size code 203, 1/4 in-28 UNF: for all other size codes, 1/8 in PT
- * N lip seals standard
- Available with H labyrinth seals
- Δ Available with E3 triple lip seals

Nickel plated housings available, add suffix K75
 For the Selection Guide, Load Ratings and Speed Limits, see the Link-Belt 200 Series Ball Bearing Engineering section on pages 290 - 298.
 Note: Dimensions subject to change. Certified dimensions of ordered material furnished on request.

F3U200

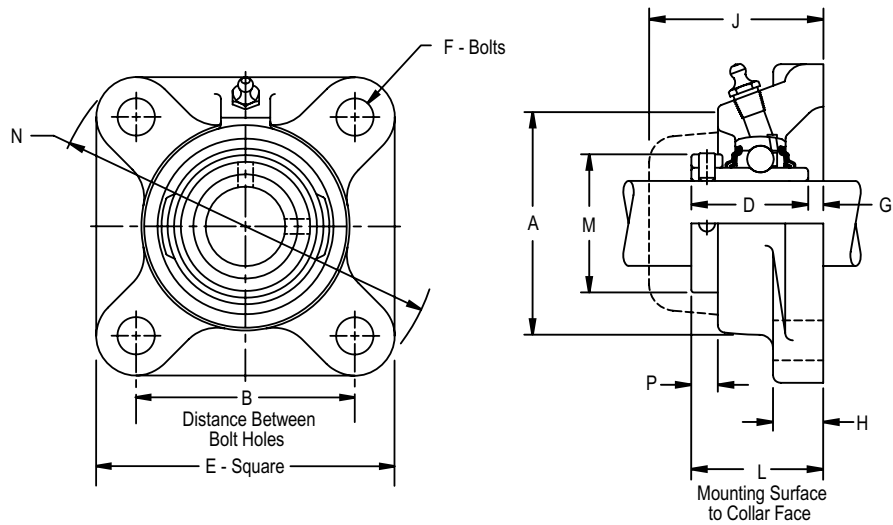
Interchange: F4BSC, FY-TF, UCF200, SF, YCJ



Photo Shows a 4-Bolt Ball Bearing Flanged Unit

Product Features

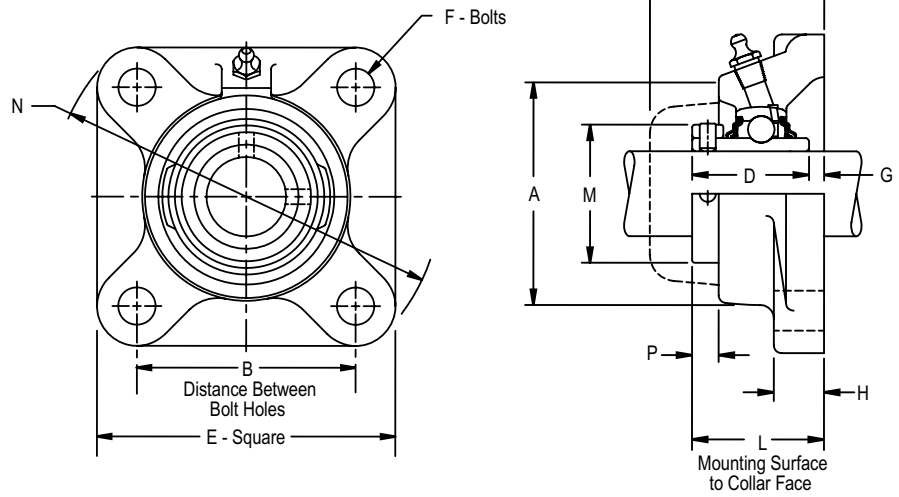
- Corrosion-resistant powder coating
 - Cast iron housing
 - Broad range of sealing options
 - Wide inner ring for increased shaft stability
 - Spring locking setscrew mount
 - Alignable & relubricatable
- See Features and Benefits for additional info on pages 286 - 287.



Bearing Dimensions

Size Code	Shaft Diameter	Part Number	B Distance Between Bolt Holes	L Mounting Surface to Collar Face	A	D	E	F Bolts	G	H	J	M	N	P	Approx. Weight
203	1/2	F3U2B08N *■	2 1/8	1 1/4	2 1/8	1 3/32	3	3/8	5/32	1/2	1 25/32	-	3 7/8	1/4	1.00
	5/8	F3U210N *■													
	11/16	F3U211N *■													
	17.00	F3U2M17N *■	53.98	31.80	54.00	27.78	76.20	10.00	4.00	12.70	45.20	-	98.40	6.40	0.45
204	3/4	F3U212N *■	2 1/2	1 31/64	2 7/16	1 9/32	3 3/8	3/8	13/64	9/16	2 1/64	-	4 13/32	9/32	1.50
	20.00	F3U2M20N *■	63.50	37.70	61.90	32.54	85.70	10.00	5.20	14.30	51.20	-	111.90	7.10	0.68
205	7/8	F3U214N *Δ■	2 3/4	1 35/64	2 11/16	1 23/64	3 3/4	7/16	3/16	19/32	2	-	4 29/32	19/64	1.90
	15/16	F3U215N *Δ■													
	1	F3U216N *Δ■													
	25.00	F3U2M25N *Δ■													
206	1 1/8	F3U218N *Δ■	3 1/4	1 47/64	3 3/16	1 9/16	4 1/4	7/16	11/64	19/32	2 15/64	-	5 19/32	7/16	3.10
	1 3/16	F3U219N *Δ■													
	1 1/4	F3U2E20N *Δ■													
	30.00	F3U2M30N *Δ■													
207	1 1/4	F3U220N *Δ■	3 5/8	1 59/64	3 5/8	1 49/64	4 5/8	1/2	5/32	5/8	2 23/64	-	6 1/8	33/64	3.90
	1 3/8	F3U222N *Δ■													
	1 7/16	F3U223N *Δ■													
	35.00	F3U2M35N *Δ■													
208	1 1/2	F3U224N *Δ■	4	2 5/64	4	1 29/32	5 1/8	1/2	11/64	5/8	2 35/64	-	6 25/32	1/2	5.00
	40.00	F3U2M40N *Δ■	101.60	52.80	101.60	48.42	130.20	12.00	4.40	15.90	64.70	-	172.20	12.70	2.25
209	1 5/8	F3U226N *Δ■	4 1/8	2 9/64	4 1/4	2 1/32	5 3/8	1/2	7/64	5/8	2 9/16	-	7 3/32	35/64	6.20
	1 11/16	F3U227N *Δ■													
	1 3/4	F3U228N *Δ■													
	45.00	F3U2M45N *Δ■													
210	1 15/16	F3U231N *Δ■	4 3/8	2 19/64	4 1/2	2 3/32	5 5/8	1/2	13/64	3/4	2 13/16	-	7 7/16	9/16	6.90
	2	F3U2E32N *Δ■													
	50.00	F3U2M50N *Δ■													
211	2	F3U232N *Δ■	5 1/8	2 9/16	4 15/16	2 1/4	6 3/8	5/8	5/16	29/32	3 11/64	-	8 1/2	5/8	8.90
	2 3/16	F3U235N *Δ■													
	55.00	F3U2M55N *Δ■													
212	2 1/4	F3U236N *Δ■	5 5/8	2 27/32	5 3/8	2 1/2	6 7/8	5/8	11/32	15/16	3 25/64	-	9 7/32	41/64	11.90
	2 3/8	F3U238N *Δ■													
	2 7/16	F3U239N *Δ■													
60.00	F3U2M60N *Δ■	142.88	72.20	136.50	63.50	174.60	16.00	8.70	23.80	86.10	-	234.20	16.30	5.35	

Continued...



Continued...

Bearing Dimensions

Size Code	Shaft Diameter	Part Number	B Distance Between Bolt Holes	L Mounting Surface to Collar Face	A	D	E	F Bolts	G	H	J	M	N	P	Approx. Weight
213	2 1/2	F3U240N *Δ	5 7/8	2 25/32	5 7/8	2 11/16	7 3/8	5/8	3/32	3/4	3 5/32	4 3/16	9 13/16	5/8	14.40
	2 11/16	F3U243N *Δ													
	65.00	F3U2M65N *Δ	149.22	70.60	149.20	68.26	187.30	16.00	2.40	19.00	80.20	106.40	249.20	15.90	6.50
215	2 3/4	F3U244N *Δ	6	2 31/32	6 3/8	2 7/8	7 3/4	3/4	3/32	3/4	3 3/8	4 9/8	10 1/4	11/16	17.40
	2 19/16	F3U247N *Δ													
	3	F3U2E48N *Δ													
	75.00	F3U2M75N *Δ	152.40	75.40	161.90	73.02	196.80	20.00	2.40	19.00	85.70	117.50	260.40	17.50	7.85
217	3 7/16	F3U255N *Δ	6 3/4	3 21/32	7 1/2	3 9/16	8 9/16	3/4	3/32	1	4 1/32	5 3/16	11 3/8	3/4	25.70
	3 1/2	F3U2E56N *Δ													
	85.00	F3U2M85N *Δ													

Additional Notes

- Please call 1-866-REXNORD for availability
- Lubrication fitting tap size: for size code 203, 1/4 in-28 UNF; for all other size codes, 1/8 in PT
- Size codes 203 to 212 don't have mounting collars
- * N lip seals standard
- Available with H labyrinth seals

- Δ Available with E3 triple lip seals
- Nickel plated housings available, add suffix K75
- For the Selection Guide, Load Ratings and Speed Limits, see the Link-Belt 200 Series Ball Bearing Engineering section on pages 290 - 298.
- Note: Dimensions subject to change. Certified dimensions of ordered material furnished on request.

F3W200

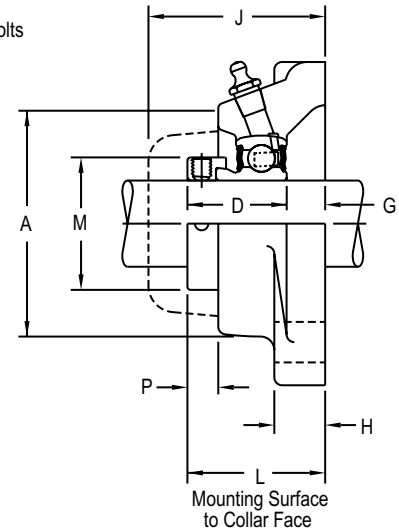
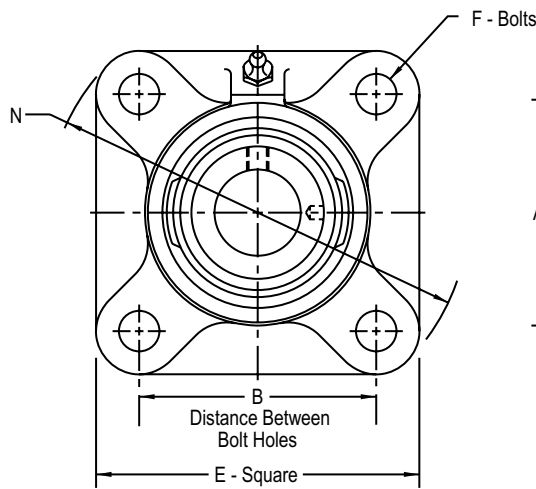
Interchange: F4BSXV, FY-FM, FHF200-G, VF4E100, VCJ



Photo Shows a 4-Bolt Ball Bearing Flanged Unit

Product Features

- Corrosion-resistant powder coating
- Cast iron housing
- Eccentric cam locking device
- Alignable & relubricatable
- See Features and Benefits for additional info on pages 286 - 287.



Bearing Dimensions

Size Code	Shaft Diameter	Part Number	B Distance Between Bolt Holes	L Mounting Surface to Collar Face	A	D	E	F Bolts	G	H	J	M	N	P	Approx. Weight
203	1/2	F3W2B08E▲	2 1/8	1 31/64	2 1/8	1 1/8	3	3/8	23/64	1/2	1 25/32	1 1/8	3 7/8	15/32	0.80
	5/8	F3W210E▲													
204	3/4	F3W212E▲	2 1/2	1 21/32	2 7/16	1 7/32	3 3/8	3/8	7/16	9/16	2 1/64	1 9/16	4 13/32	29/64	1.30
	7/8	F3W214E▲													
205	15/16	F3W215E▲	2 3/4	1 49/64	2 11/16	1 7/32	3 3/4	7/16	29/64	19/32	2	1 1/2	4 29/32	27/64	1.80
	1	F3W216E▲													
	1 1/8	F3W218E▲													
206	1 3/16	F3W219E▲	3 1/4	1 53/64	3 3/16	1 13/32	4 1/4	7/16	27/64	19/32	2 15/64	1 3/4	5 19/32	33/64	2.90
	1 1/4	F3W220E▲													
	1 1/4	F3W220E▲													
207	1 3/8	F3W222E▲	3 5/8	1 31/32	3 5/8	1 17/32	4 5/8	1/2	7/16	5/8	2 23/64	2 3/16	6 1/8	9/16	3.70
	1 7/16	F3W223E▲													
	1 1/2	F3W224E▲													
208	1 5/8	F3W226E▲	4	2 3/16	4	1 23/32	5 1/8	1/2	15/32	5/8	2 35/64	2 3/8	6 25/32	39/64	4.80
	1 11/16	F3W227E▲													
	1 3/4	F3W228E▲													
	1 15/16	F3W231E▲													
210	2	F3W232E▲	4 3/8	2 5/16	4 1/2	1 23/32	5 5/8	1/2	19/32	3/4	2 13/16	2 3/4	7 7/16	37/64	6.10

Additional Notes

- Please call 1-866-REXNORD for availability
- Lubrication fitting tap size: for size code 203, 1/4 in-28 UNF; for all other size codes, 1/8 in PT
- ▲ E lip seals standard
- Nickel plated housings available, add suffix K75

For the Selection Guide, Load Ratings and Speed Limits, see the Link-Belt 200 Series Ball Bearing Engineering section on pages 290 - 298.

Note: Dimensions subject to change. Certified dimensions of ordered material furnished on request.

F3S200

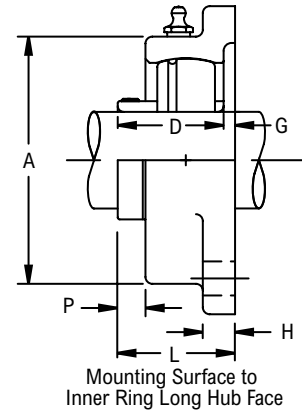
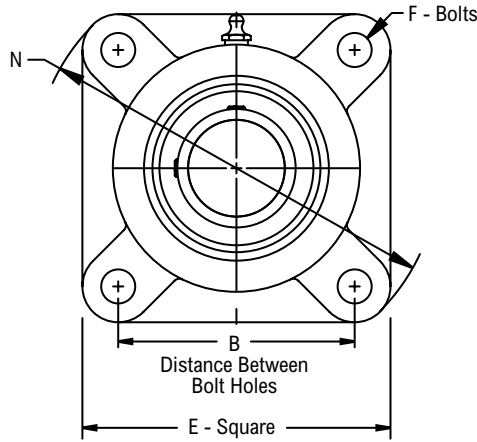
Interchange: F4BVSC, FY-RM, FHSF200-G, VF4S100, SCJ



Photo Shows a 4-Bolt Ball Bearing Flanged Unit

Product Features

- Corrosion-resistant powder coating
- Cast iron housing
- Broad range of sealing options
- Spring locking setscrew mount
- Alignable & relubricatable
- See Features and Benefits for additional info on pages 286 - 287.



Bearing Dimensions

Size Code	Shaft Diameter	Part Number	B Distance Between Bolt Holes	L Mounting Surface to Inner Ring Long Hub Face	A	D	E	F Bolts	G	H	N	P	Approx. Weight
203	1/2	F3S2B08E♦♦ □Δ	2 1/8	1 1/8	2 1/16	63/64	3	3/8	9/64	3/8	3 7/8	5/16	0.99
	5/8	F3S210E♦♦ □Δ											0.95
	1 1/16	F3S211E♦♦ □Δ											0.93
204	3/4	F3S212E♦♦ □Δ	2 1/2	1 9/32	2 5/16	1 1/8	3 3/8	3/8	9/64	3/8	4 13/32	13/32	1.30
	20.00	F3S2M20E♦♦ □Δ											63.50
205	7/8	F3S214E♦♦ □Δ	2 3/4	1 5/16	2 11/16	1 11/64	3 3/4	7/16	1/8	7/16	4 29/32	7/16	1.71
	15/16	F3S215E♦♦ □Δ											1.68
	1	F3S216E♦♦ □Δ											1.65
	25.00	F3S2M25E♦♦ □Δ											69.85
206	1 1/8	F3S218E♦♦ □Δ	3 1/4	1 1/2	3 3/16	1 11/32	4 1/4	7/16	9/64	1/2	5 19/32	9/16	2.50
	1 3/16	F3S219E♦♦ □Δ											2.46
	1 1/4	F3S2E20E♦♦ □Δ											2.42
	30.00	F3S2M30E♦♦ □Δ	82.55	38.10	81.00	34.14	108.00	10.00	3.60	12.70	142.10	14.30	1.10
207	1 1/4	F3S220E♦♦ □Δ	3 5/8	1 29/32	3 11/16	1 9/16	4 5/8	1/2	9/64	1/2	6 1/8	21/32	3.41
	1 3/8	F3S222E♦♦ □Δ											3.31
	1 7/16	F3S223E♦♦ □Δ											3.26
	35.00	F3S2M35E♦♦ □Δ											92.08
208	1 1/2	F3S224E♦♦ □Δ	4	1 13/16	4 1/16	1 21/32	5 1/4	1/2	5/32	9/16	6 25/32	21/32	4.49
	1 5/8	F3S2E26E♦♦ □Δ											4.35
	40.00	F3S2M40E♦♦ □Δ											101.60
209	1 5/8	F3S226E♦♦ □Δ	4 1/8	1 29/32	4 5/16	1 49/64	5 3/8	9/16	1/8	9/16	7 3/32	23/32	4.85
	1 11/16	F3S227E♦♦ □Δ											4.78
	1 3/4	F3S228E♦♦ □Δ											4.70
210	1 7/8	F3S230E♦♦ □Δ	4 3/8	1 29/32	4 1/2	1 13/16	5 5/8	9/16	7/64	9/16	7 7/16	23/32	5.31
	1 15/16	F3S231E♦♦ □Δ											5.22
	2	F3S2E32E♦♦ □Δ											5.13
211	2	F3S232E♦♦ □Δ	5 1/8	2	5 3/16	1 13/16	6 3/8	5/8	11/64	5/8	8 1/2	11/16	7.53
	2 3/16	F3S235E♦♦ □Δ											7.23
	2 1/4	F3S2E36E♦♦ □Δ											7.13
212	2 1/4	F3S236E♦♦ □Δ	5 5/8	2 3/32	5 7/16	1 57/64	6 7/8	5/8	13/64	11/16	9 9/32	21/32	9.25
	2 3/8	F3S238E♦♦ □Δ											9.01
	2 7/16	F3S239E♦♦ □Δ											8.89
215	2 15/16	F3S247E♦♦ □Δ	6	2 13/32	6 7/16	2 17/64	7 3/4	3/4	1/8	3/4	10 1/4	23/32	13.19

Additional Notes

- Please call 1-866-REXNORD for availability
- Lubrication fitting tap size: for size code 203, 1/4 in-28 UNF: for all other size codes, 1/8 in PT
- Lip seals standard
- ♦ Available with E1 viton seals for all size codes
- Available with free running style seals, add suffix ♦ FF, □ HFF or Δ MHFF for all size codes

- Nickel plated housings available, add suffix K75
- For the Selection Guide, Load Ratings and Speed Limits, see the Link-Belt 200 Series Ball Bearing Engineering section on pages 290 - 298.
- Note: Dimensions subject to change. Certified dimensions of ordered material furnished on request.

FB3U200

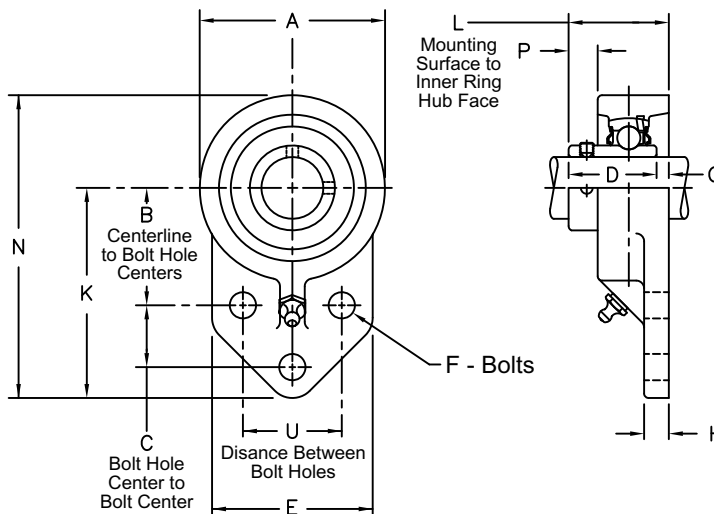
Interchange: *FBSC, UCFB200, FB*



Photo Shows a 3-Bolt Ball Bearing Flanged Bracket Unit

Product Features

- Corrosion-resistant powder coating
- Cast iron housing
- Broad range of sealing options
- Wide inner ring for increased shaft stability
- Spring locking setscrew mount
- Alignable & relubricatable
- See Features and Benefits for additional info on pages 286 - 287.



Bearing Dimensions

Size Code	Shaft Diameter	Part Number	B Centerline to Bolt Hole Centers	C Bolt Hole Center to Bolt Center	L Mounting Surface to Inner Ring Long Hub Face	U Distance Between Bolt Holes	A	D	E	F Bolts	G	H	K	N	P	Approx. Weight
204	³ / ₄	FB3U212N *■	1 ¹¹ / ₁₆	⁷ / ₈	1 ¹¹ / ₃₂	1 ¹ / ₂	2 ¹ / ₂	1 ⁹ / ₃₂	2 ³ / ₈	³ / ₈	¹ / ₁₆	⁵ / ₁₆	3	4 ¹ / ₄	¹¹ / ₃₂	1.40
	20.00	FB3U2M20N *■	42.90	22.20	34.10	38.10	63.50	32.50	60.30	10.00	1.60	7.90	76.20	108.00	8.70	0.63
205	⁷ / ₈	FB3U214N *■	1 ¹³ / ₁₆	1 ¹ / ₈	1 ²⁹ / ₆₄	1 ⁵ / ₈	2 ³ / ₄	1 ²³ / ₆₄	2 ¹ / ₂	³ / ₈	³ / ₃₂	³ / ₈	3 ³ / ₈	4 ³ / ₄	¹⁹ / ₆₄	1.90
	¹⁵ / ₁₆	FB3U215N *■														
	1	FB3U216N *■	46.00	28.60	38.90	41.30	69.80	34.53	63.50	10.00	2.40	9.50	85.70	120.60	7.50	0.86
	25.00	FB3U2M25N *■														
206	1 ¹ / ₈	FB3U218N *■	2 ¹ / ₁₆	1 ¹ / ₄	1 ⁵ / ₈	1 ⁷ / ₈	3 ¹ / ₄	1 ⁹ / ₁₆	2 ³ / ₄	³ / ₈	¹ / ₁₆	³ / ₈	3 ³ / ₄	5 ³ / ₈	³ / ₈	2.50
	1 ³ / ₁₆	FB3U219N *■														
	1 ¹ / ₄	FB3U2E20N *■	52.30	31.80	43.70	47.60	82.60	39.69	69.80	10.00	1.60	9.50	95.20	136.50	9.50	1.13
	30.00	FB3U2M30N *■														
207	1 ¹ / ₄	FB3U220N *■	2 ³ / ₈	1 ¹ / ₄	1 ⁵⁹ / ₆₄	2	3 ³ / ₄	1 ⁴⁹ / ₆₄	3 ¹ / ₄	¹ / ₂	⁵ / ₃₂	¹ / ₂	4 ¹ / ₄	6 ¹ / ₈	³¹ / ₆₄	3.40
	1 ³ / ₈	FB3U222N *■														
	1 ⁷ / ₁₆	FB3U223N *■	60.30	31.80	48.80	50.80	95.20	44.85	82.60	12.00	4.00	12.70	108.00	155.60	12.30	1.53
	35.00	FB3U2M35N *■														

Additional Notes

- Please call 1-866-REXNORD for availability
- Lubrication fitting tap size, 1/4 in-28 UNF
- * N lip seals standard
- Available with H labyrinth seals
- Δ Available with E3 triple lip seals
- Nickel plated housings available, add suffix K75

For the Selection Guide, Load Ratings and Speed Limits, see the Link-Belt 200 Series Ball Bearing Engineering section on pages 290 - 298.

Note: Dimensions subject to change. Certified dimensions of ordered material furnished on request.

FB3S200

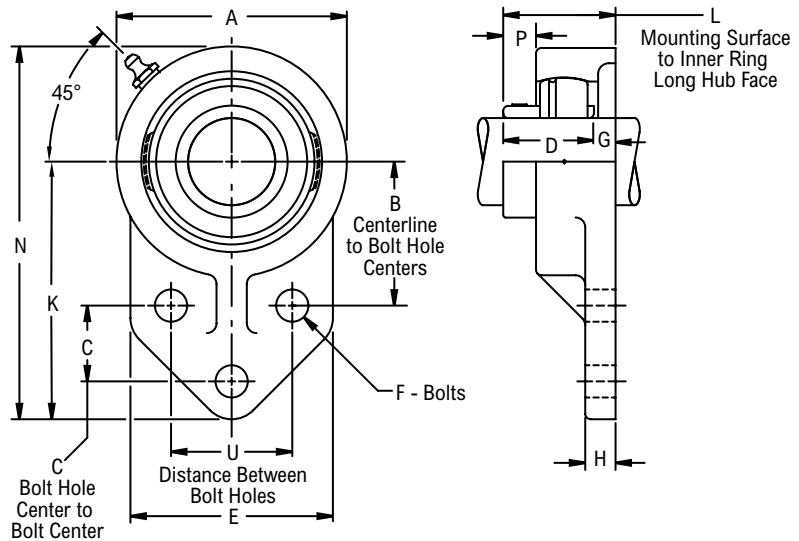
Interchange: *FBVSC*



Photo Shows a 3-Bolt Ball Bearing Flanged Bracket Unit

Product Features

- Corrosion-resistant powder coating
- Cast iron housing
- Broad range of sealing options
- Spring locking setscrew mount
- Alignable & relubricatable
- See Features and Benefits for additional info on pages 286 - 287.



Bearing Dimensions

Size Code	Shaft Diameter	Part Number	B Centerline to Bolt Hole Centers	C Bolt Hole Center to Bolt Center	L Mounting Surface to Inner Ring Long Hub Face	U Distance Between Bolt Holes	A	D	E	F Bolts	G	H	K	N	P	Approx. Weight	
204	³ / ₄	FB3S212E●●□△	1 ¹¹ / ₁₆	⁷ / ₈	1 ³ / ₈	1 ¹ / ₂	2 ¹ / ₂	1 ¹ / ₈	2 ³ / ₈	³ / ₈	¹ / ₄	⁵ / ₁₆	3	4 ¹ / ₄	²⁵ / ₆₄	1.44	
	20.00	FB3S2M20E●●□△	42.90	22.20	34.90	38.10	63.50	28.58	60.30	10.00	6.40	7.90	76.20	108.00	9.90	0.60	
205	⁷ / ₈	FB3S214E●●□△	1 ¹³ / ₁₆	1 ¹ / ₈	1 ¹⁷ / ₃₂	1 ⁵ / ₈	2 ³ / ₄	1 ¹¹ / ₆₄	2 ¹ / ₂	³ / ₈	²³ / ₆₄	³ / ₈	3 ³ / ₈	4 ³ / ₄	²⁷ / ₆₄	1.80	
	¹⁵ / ₁₆	FB3S215E●●□△															
	1	FB3S216E●●□△	25.00	FB3S2M25E●●□△	46.00	28.60	38.90	41.30	69.80	29.77	63.50	10.00	9.10	9.50	85.70	120.60	10.70
206	1 ¹ / ₈	FB3S218E●●□△	2 ¹ / ₁₆	1 ¹ / ₄	1 ⁴⁹ / ₆₄	1 ⁷ / ₈	3 ¹ / ₄	1 ¹¹ / ₃₂	2 ³ / ₄	³ / ₈	¹⁷ / ₆₄	³ / ₈	3 ³ / ₄	5 ³ / ₈	³⁵ / ₆₄	2.10	
	1 ³ / ₁₆	FB3S219E●●□△															
	1 ¹ / ₄	FB3S2E20E●●□△															30.00
207	1 ¹ / ₄	FB3S220E●●□△	2 ³ / ₈	1 ¹ / ₄	1 ⁶¹ / ₆₄	2	3 ³ / ₄	1 ⁹ / ₁₆	3 ¹¹ / ₃₂	¹ / ₂	²⁵ / ₆₄	¹ / ₂	4 ¹ / ₄	6 ¹ / ₈	⁴¹ / ₆₄	3.45	
	1 ³ / ₈	FB3S222E●●□△															
	1 ⁷ / ₁₆	FB3S223E●●□△															35.00

Additional Notes

- Please call 1-866-REXNORD for availability
- Lubrication fitting tap size: for size codes 204 thru 205, 1/4-28 UNF; for all other size codes, 1/8 in PT
- Lip seals standard
- ◆ Available with E1 viton seals
- Available with free running style seals, add suffix ● FF, □ HFF or △ MHFF

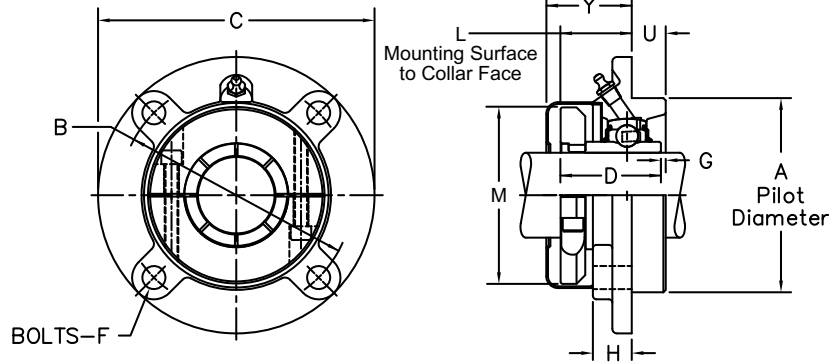
- Nickel plated housings available, add suffix K75
- For the Selection Guide, Load Ratings and Speed Limits, see the Link-Belt 200 Series Ball Bearing Engineering section on pages 290 - 298.
- Note: Dimensions subject to change. Certified dimensions of ordered material furnished on request.

FC3CL200N

Interchange: *FCDL, SFC-T*



Photo Shows a 4-Bolt Ball Bearing Flanged Cartridge Unit



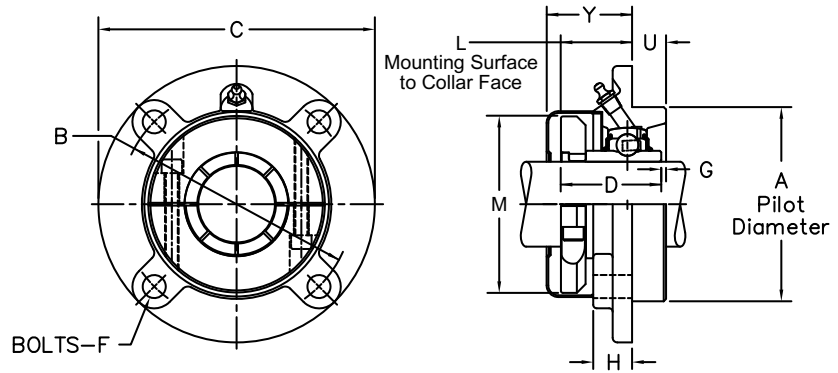
Product Features

- Corrosion resistant powder coating
- Cast iron housing
- Broad range of sealing options
- Wide inner ring for increased shaft stability
- Spring locking setscrew mount
- Alignable and relubricatable
- Black Oxide

Bearing Dimensions

Size Code	Shaft Diameter	Part Number	A Pilot Diameter	B Bolt Hole Circle Diameter	L Mounting Surface to Collar Face	C	D	F Bolts	G	H	M	U	Y	Approx. Weight
205	$\frac{7}{8}$	FC3CL214N* Δ	3.000	$3\frac{5}{8}$	$\frac{61}{64}$	$4\frac{3}{8}$	$1\frac{29}{64}$	$\frac{3}{8}$	-	$\frac{5}{8}$	$2\frac{3}{32}$	$\frac{1}{2}$	$1\frac{29}{64}$	3.00
	$\frac{15}{16}$	FC3CL215N* Δ												
	1	FC3CL216N* Δ												
	25.00	FC3CL2M25N* Δ	76.200	92.08	24.21	111.10	36.91	10.00	-	15.90	53.18	12.70	36.91	1.35
206	$1\frac{1}{8}$	FC3CL218N* Δ	3.375	$4\frac{1}{8}$	$1\frac{5}{64}$	5	$1\frac{17}{32}$	$\frac{7}{16}$	-	$\frac{13}{16}$	$2\frac{15}{32}$	$\frac{27}{64}$	$1\frac{3}{4}$	4.50
	$1\frac{3}{16}$	FC3CL219N* Δ												
	$1\frac{1}{4}$	FC3CL2E20N* Δ												
	30.00	FC3CL2M30N* Δ	85.720	104.78	27.38	127.00	38.89	10.00	-	20.60	62.71	10.70	44.45	2.00
207	$1\frac{1}{4}$	FC3CL220N* Δ	3.625	$4\frac{3}{8}$	$1\frac{13}{32}$	$5\frac{1}{4}$	$1\frac{47}{64}$	$\frac{7}{16}$	$\frac{3}{16}$	$1\frac{1}{16}$	$2\frac{57}{64}$	$\frac{15}{32}$	$2\frac{1}{64}$	4.60
	$1\frac{3}{8}$	FC3CL222N* Δ												
	$1\frac{7}{16}$	FC3CL223N* Δ												
	35.00	FC3CL2M35N* Δ	92.080	111.20	35.72	133.40	44.05	10.00	4.80	27.00	73.42	11.90	51.20	2.10
208	$1\frac{1}{2}$	FC3CL224N* Δ	3.625	$4\frac{3}{8}$	$1\frac{33}{64}$	$5\frac{1}{4}$	$1\frac{31}{32}$	$\frac{7}{16}$	$\frac{1}{32}$	$1\frac{1}{32}$	$3\frac{1}{16}$	$\frac{15}{32}$	$2\frac{1}{32}$	4.30
	40.00	FC3CL2M40N* Δ												
209	$1\frac{5}{8}$	FC3CL226N* Δ	4.250	$5\frac{1}{8}$	$1\frac{17}{32}$	$6\frac{1}{8}$	$1\frac{31}{32}$	$\frac{1}{2}$	-	$1\frac{1}{16}$	$3\frac{17}{64}$	$\frac{15}{32}$	$2\frac{1}{32}$	6.30
	$1\frac{11}{16}$	FC3CL227N* Δ												
	$1\frac{3}{4}$	FC3CL228N* Δ												
	45.00	FC3CL2M45N* Δ	107.950	130.18	38.89	155.60	50.01	12.00	-	27.00	82.95	11.90	51.59	2.84
210	$1\frac{15}{16}$	FC3CL231N* Δ	4.500	$5\frac{3}{8}$	$1\frac{19}{32}$	$6\frac{3}{8}$	$2\frac{5}{64}$	$\frac{1}{2}$	$\frac{11}{64}$	$1\frac{13}{64}$	$3\frac{5}{8}$	$\frac{5}{8}$	$2\frac{7}{16}$	7.40
	50.00	FC3CL2M50N* Δ												
211A	2	FC4CL232N* Δ	4.500	$5\frac{3}{8}$	$1\frac{21}{32}$	$6\frac{3}{8}$	$2\frac{15}{64}$	$\frac{1}{2}$	$\frac{1}{32}$	$1\frac{1}{32}$	$3\frac{29}{32}$	$\frac{5}{8}$	$2\frac{1}{4}$	7.70
	55.00	FC4CL2M55N* Δ												
211B	2	FC3CL232N* Δ	5.000	6	$1\frac{15}{32}$	$7\frac{1}{8}$	$2\frac{15}{64}$	$\frac{9}{16}$	$\frac{5}{32}$	1	$3\frac{29}{32}$	$\frac{7}{8}$	$2\frac{1}{4}$	9.90
	$2\frac{3}{16}$	FC3CL235N* Δ												
	55.00	FC3CL2M55N* Δ												

Continued...



Continued...

Bearing Dimensions

Size Code	Shaft Diameter	Part Number	A Pilot Diameter	B Bolt Hole Circle Diameter	L Mounting Surface to Collar Face	C	D	F Bolts	G	H	M	U	Y	Approx. Weight
212	2 1/4	FC3CL236N*Δ	5.500	6 1/2	1 39/64	7 5/8	2 19/32	9/16	-	1	4 3/16	7/8	2 1/4	12.00
	2 3/8	FC3CL238N*Δ												
	2 7/16	FC3CL239N*Δ												
	60.00	FC3CL2M60N*Δ	139.700	165.10	40.88	193.70	65.88	14.00	-	25.40	106.36	22.20	57.15	5.40
213	2 1/2	FC3CL240N*Δ	6.375	7 1/2	1 7/8	8 3/4	2 3/4	5/8	3/16	1 3/16	4 51/64	1 1/16	2 23/64	17.00
	2 11/16	FC3CL243N*Δ												
	65.00	FC3CL2M65N*Δ												
215	2 3/4	FC3CL244N*Δ	6.375	7 1/2	1 55/64	8 3/4	2 29/32	5/8	3/16	1 1/16	5 1/4	1 1/4	2 23/64	17.70
	2 15/16	FC3CL247N*Δ												
	3	FC3CL2E48N*Δ												
	75.00	FC3CL2M75N*Δ	161.920	190.50	222.20	16.00	4.80	27.00	31.80	8.00				
217	3 7/16	FC3CL255N*Δ	7.375	8 5/8	2 7/16	10 1/4	3 39/64	3/4	-	1 5/8	5 23/32	1 5/32	3 1/8	34.00
	3 1/2	FC3CL2E56N*Δ												
	85.00	FC3CL2M85N*Δ												
220	3 15/16	FC3CL263N*	8.120	9 3/8	3 11/16	10 7/8	4 7/64	3/4	-	2 1/8	6 31/64	1 1/8	3 27/64	41.80
	4	FC3CL2E64N*												
	100.00	FC3CL2M100N*												

Additional Notes

- Please call 1-866-REXNORD for availability
- Lubrication fitting tap size: for size code 203, 1/4 in-28 UNF: for all other size codes, 1/8 in PT
- * N lip seals with flingers standard
- Available with H labyrinth seals

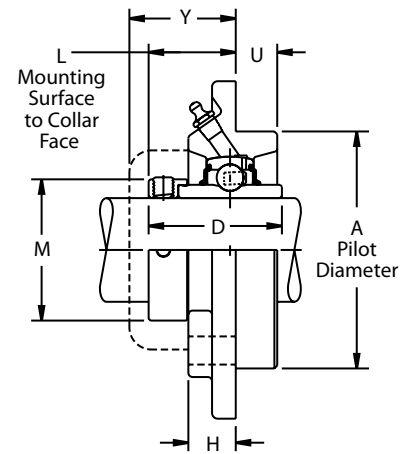
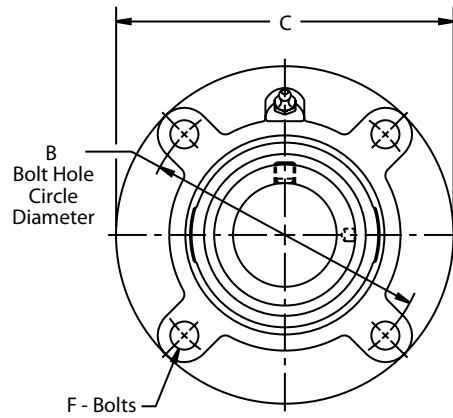
- Δ Available with E3 triple lip seals
- Nickel plated housings available, add suffix K75
- For the Selection Guide, Load Ratings and Speed Limits, see the Link-Belt 200 Series Ball Bearing Engineering section on pages 290 - 298.
- Note: Dimensions subject to change. Certified dimensions of ordered material furnished on request.

FC3Y200

Interchange: FCSXR



Photo Shows a 4-Bolt Ball Bearing Flanged Cartridge Unit



Product Features

- Corrosion-resistant powder coating
- Cast iron housing
- Broad range of sealing options
- Wide inner ring for increased shaft stability
- Eccentric cam locking device
- Alignable & relubricatable
- See Features and Benefits for additional info on pages 286 - 287.

Bearing Dimensions

Size Code	Shaft Diameter	Part Number	A Pilot Diameter	B Bolt Hole Circle Diameter	L Mounting Surface to Collar Face	C	D	F Bolts	H	M	U	Y	Approx. Weight
205	$\frac{7}{8}$	FC3Y214N * Δ	3.000	$3 \frac{5}{8}$	$1 \frac{1}{8}$	$4 \frac{3}{8}$	$1 \frac{3}{4}$	$\frac{3}{8}$	$\frac{5}{8}$	$1 \frac{1}{2}$	$\frac{1}{2}$	$1 \frac{7}{16}$	3.10
	$\frac{15}{16}$	FC3Y215N * Δ											
	1	FC3Y216N * Δ											
206	$1 \frac{1}{8}$	FC3Y218N * Δ	3.375	$4 \frac{1}{8}$	$1 \frac{3}{8}$	5	$1 \frac{29}{32}$	$\frac{7}{16}$	$\frac{13}{16}$	$1 \frac{3}{4}$	$\frac{27}{64}$	$1 \frac{23}{32}$	4.60
	$1 \frac{3}{16}$	FC3Y219N * Δ											
	$1 \frac{1}{4}$	FC3Y220N * Δ											
207	$1 \frac{1}{4}$	FC3Y220N * Δ	3.625	$4 \frac{3}{8}$	$1 \frac{21}{32}$	$5 \frac{1}{4}$	$2 \frac{1}{64}$	$\frac{7}{16}$	$1 \frac{1}{16}$	$2 \frac{3}{16}$	$\frac{15}{32}$	2	4.90
	$1 \frac{3}{8}$	FC3Y222N * Δ											
	$1 \frac{7}{16}$	FC3Y223N * Δ											
208	$1 \frac{1}{2}$	FC3Y224N * Δ	3.625	$4 \frac{3}{8}$	$1 \frac{43}{64}$	$5 \frac{1}{4}$	$2 \frac{7}{32}$	$\frac{7}{16}$	$1 \frac{1}{32}$	$2 \frac{3}{8}$	$\frac{15}{32}$	$2 \frac{1}{16}$	4.60
	$1 \frac{5}{8}$	FC3Y226N * Δ											
	$1 \frac{11}{16}$	FC3Y227N * Δ											
209	$1 \frac{3}{4}$	FC3Y228N * Δ	4.250	$5 \frac{1}{8}$	$1 \frac{45}{64}$	$6 \frac{1}{8}$	$2 \frac{7}{32}$	$\frac{1}{2}$	$1 \frac{1}{16}$	$2 \frac{1}{2}$	$\frac{15}{32}$	$2 \frac{5}{64}$	6.60
	$1 \frac{15}{16}$	FC3Y231N * Δ											
210	$1 \frac{15}{16}$	FC3Y231N * Δ	4.500	$5 \frac{3}{8}$	$1 \frac{7}{8}$	$6 \frac{3}{8}$	$2 \frac{15}{32}$	$\frac{1}{2}$	$1 \frac{13}{64}$	$2 \frac{3}{4}$	$\frac{5}{8}$	$2 \frac{1}{4}$	7.70
211A	2	FC4Y232N * Δ	4.500	$5 \frac{3}{8}$	$1 \frac{31}{32}$	$6 \frac{3}{8}$	$2 \frac{13}{16}$	$\frac{1}{2}$	$1 \frac{1}{32}$	3	$\frac{5}{8}$	$2 \frac{17}{64}$	7.20
211B	2	FC3Y232N * Δ	5.000	6	$1 \frac{27}{32}$	$7 \frac{1}{8}$	$2 \frac{13}{16}$	$\frac{9}{16}$	1	3	$\frac{7}{8}$	$2 \frac{1}{8}$	11.00
	$2 \frac{3}{16}$	FC3Y235N * Δ											
	$2 \frac{1}{4}$	FC3Y236N * Δ											
212	$2 \frac{3}{8}$	FC3Y238N * Δ	5.500	$6 \frac{1}{2}$	$1 \frac{29}{32}$	$7 \frac{5}{8}$	$3 \frac{1}{16}$	$\frac{9}{16}$	1	$3 \frac{5}{16}$	$\frac{7}{8}$	$2 \frac{11}{64}$	12.50
	$2 \frac{7}{16}$	FC3Y239N * Δ											

Additional Notes

- Please call 1-866-REXNORD for availability
- Lubrication fitting tap size: for size codes 206 and below, 1/4 in-28 UNF; for all other size codes, 1/8 in PT
- Pilot Diameter tolerance, +.000 in/-.002 in (+0.00 mm/-0.05 mm)
- Bore tolerance for mounting, +.002 in/-.000 in (+0.05 mm/-0.00 mm)
- * N lip seals standard

- Available with H labyrinth seals
- ▲ Available with E3 triple lip seals
- For the Selection Guide, Load Ratings and Speed Limits, see the Link-Belt 200 Series Ball Bearing Engineering section on pages 290 - 298.
- Note: Dimensions subject to change. Certified dimensions of ordered material furnished on request.

FC3U200

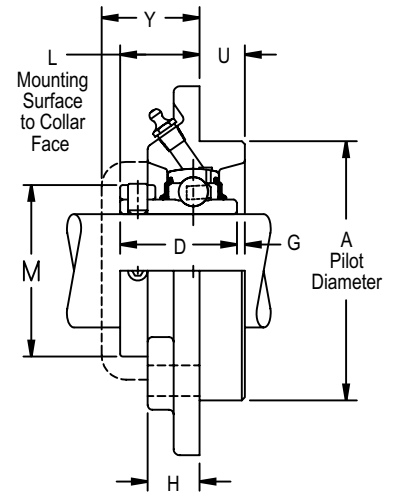
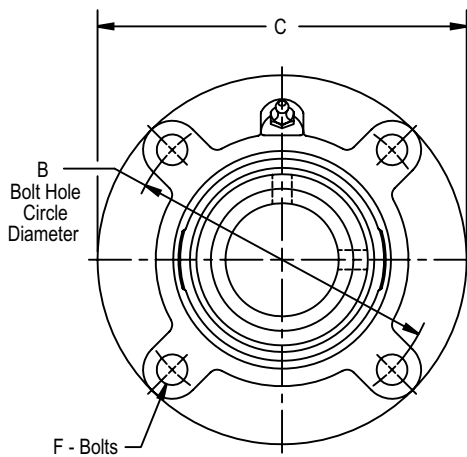
Interchange: FCSC, SFC, RFC



Photo Shows a 4-Bolt Ball Bearing Flanged Cartridge Unit

Product Features

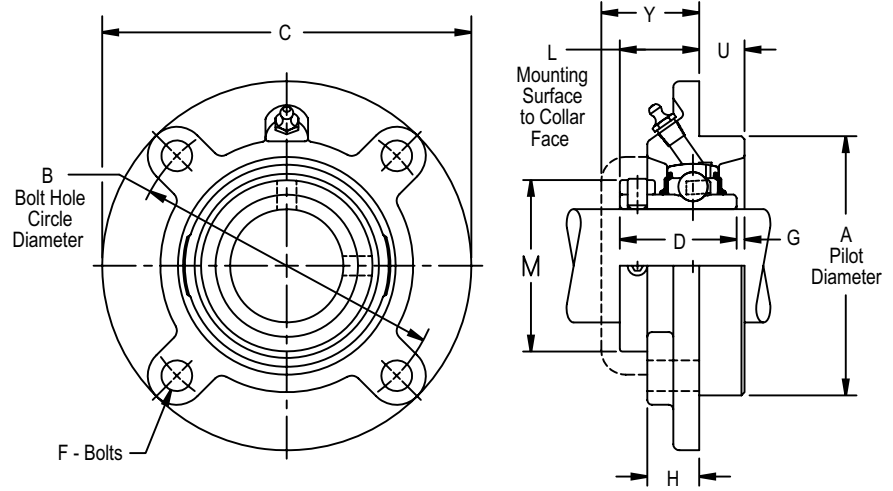
- Corrosion-resistant powder coating
- Cast iron housing
- Broad range of sealing options
- Wide inner ring for increased shaft stability
- Spring locking setscrew mount
- Alignable & relubricatable
- See Features and Benefits for additional info on pages 286 - 287.



Bearing Dimensions

Size Code	Shaft Diameter	Part Number	A Pilot Diameter	B Bolt Hole Circle Diameter	L Mounting Surface to Collar Face	C	D	F Bolts	G	H	M	U	Y	Approx. Weight
205	$\frac{7}{8}$	FC3U214N* Δ	3.000	$3\frac{5}{8}$	$\frac{55}{64}$	$4\frac{3}{8}$	$1\frac{23}{64}$	$\frac{3}{8}$	-	$\frac{5}{8}$	-	$\frac{1}{2}$	$1\frac{7}{16}$	3.00
	$\frac{15}{16}$	FC3U215N* Δ												
	1	FC3U216N* Δ												
	25.00	FC3U2M25N* Δ	76.200	92.08	21.80	111.10	34.53	10.00	-	15.90	-	12.70	36.50	1.35
206	$1\frac{1}{8}$	FC3U218N* Δ	3.375	$4\frac{1}{8}$	$1\frac{9}{64}$	5	$1\frac{9}{16}$	$\frac{7}{16}$	-	$\frac{13}{16}$	-	$\frac{27}{64}$	$1\frac{23}{32}$	4.50
	$1\frac{3}{16}$	FC3U219N* Δ												
	$1\frac{1}{4}$	FC3U2E20N* Δ												
	30.00	FC3U2M30N* Δ	85.720	104.78	29.00	127.00	39.69	10.00	-	20.60	-	10.70	43.70	2.00
207	$1\frac{1}{4}$	FC3U220N* Δ	3.625	$4\frac{3}{8}$	$1\frac{31}{64}$	$5\frac{1}{4}$	$1\frac{49}{64}$	$\frac{7}{16}$	$\frac{3}{16}$	$1\frac{1}{16}$	-	$\frac{15}{32}$	2	4.60
	$1\frac{3}{8}$	FC3U222N* Δ												
	$1\frac{7}{16}$	FC3U223N* Δ												
	35.00	FC3U2M35N* Δ	92.080	111.20	37.70	133.40	44.85	10.00	4.80	27.00	-	11.90	50.80	2.10
208	$1\frac{1}{2}$	FC3U224N* Δ	3.625	$4\frac{3}{8}$	$1\frac{15}{32}$	$5\frac{1}{4}$	$1\frac{29}{32}$	$\frac{7}{16}$	$\frac{1}{32}$	$1\frac{1}{32}$	-	$\frac{15}{32}$	$2\frac{1}{16}$	4.30
	40.00	FC3U2M40N* Δ												
209	$1\frac{5}{8}$	FC3U226N* Δ	4.250	$5\frac{1}{8}$	$1\frac{9}{16}$	$6\frac{1}{8}$	$2\frac{1}{32}$	$\frac{1}{2}$	-	$1\frac{1}{16}$	-	$\frac{15}{32}$	$2\frac{5}{64}$	6.30
	$1\frac{11}{16}$	FC3U227N* Δ												
	$1\frac{3}{4}$	FC3U228N* Δ												
	45.00	FC3U2M45N* Δ	107.950	130.18	39.70	155.60	51.59	12.00	-	27.00	-	11.90	52.80	2.84
210	$1\frac{15}{16}$	FC3U231N* Δ	4.500	$5\frac{3}{8}$	$1\frac{41}{64}$	$6\frac{3}{8}$	$2\frac{3}{32}$	$\frac{1}{2}$	$\frac{11}{64}$	$1\frac{13}{64}$	-	$\frac{5}{8}$	$2\frac{1}{4}$	7.40
	50.00	FC3U2M50N* Δ												
211A	2	FC4U232N* Δ	4.500	$5\frac{3}{8}$	$1\frac{21}{32}$	$6\frac{3}{8}$	$2\frac{1}{4}$	$\frac{1}{2}$	$\frac{1}{32}$	$1\frac{1}{32}$	-	$\frac{5}{8}$	$2\frac{17}{64}$	7.70
	55.00	FC4U2M55N* Δ												
211B	2	FC3U232N* Δ	5.000	6	$1\frac{17}{32}$	$7\frac{1}{8}$	$2\frac{1}{4}$	$\frac{9}{16}$	$\frac{5}{32}$	1	-	$\frac{7}{8}$	$2\frac{1}{8}$	9.90
	$2\frac{3}{16}$	FC3U235N* Δ												
	55.00	FC3U2M55N* Δ	127.000	152.40	38.90	181.00	57.15	14.00	4.00	25.40	-	22.20	54.00	4.45
212	$2\frac{1}{4}$	FC3U236N* Δ	5.500	$6\frac{1}{2}$	$1\frac{5}{8}$	$7\frac{9}{8}$	$2\frac{1}{2}$	$\frac{9}{16}$	-	1	-	$\frac{7}{8}$	$2\frac{11}{64}$	12.00
	$2\frac{3}{8}$	FC3U238N* Δ												
	$2\frac{7}{16}$	FC3U239N* Δ												
	60.00	FC3U2M60N* Δ	139.700	165.10	41.30	193.70	63.50	14.00	-	25.40	-	22.20	55.20	5.40
213	$2\frac{1}{2}$	FC3U240N* Δ	6.375	$7\frac{1}{2}$	$1\frac{13}{16}$	$8\frac{3}{4}$	$2\frac{11}{16}$	$\frac{5}{8}$	$\frac{3}{16}$	$1\frac{3}{16}$	$4\frac{3}{16}$	$1\frac{1}{16}$	$2\frac{3}{16}$	17.00
	$2\frac{11}{16}$	FC3U243N* Δ												
	65.00	FC3U2M65N* Δ	161.920	190.50	46.00	222.20	68.26	16.00	4.80	30.20	106.40	27.00	55.60	7.65
215	$2\frac{3}{4}$	FC3U244N* Δ	6.375	$7\frac{1}{2}$	$1\frac{13}{16}$	$8\frac{3}{4}$	$2\frac{7}{8}$	$\frac{5}{8}$	$\frac{3}{16}$	$1\frac{1}{16}$	$4\frac{5}{8}$	$1\frac{1}{4}$	$2\frac{7}{32}$	17.70
	$2\frac{15}{16}$	FC3U247N* Δ												

Continued...



Continued...

Bearing Dimensions

Size Code	Shaft Diameter	Part Number	A Pilot Diameter	B Bolt Hole Circle Diameter	L Mounting Surface to Collar Face	C	D	F Bolts	G	H	M	U	Y	Approx. Weight
215	3	FC3U2E48N*Δ	6.375	7 1/2	1 13/16	8 3/4	2 7/8	5/8	3/16	1 1/16	4 5/8	1 1/4	2 7/32	17.70
	75.00	FC3U2M75N*Δ	161.920	190.50	46.00	222.20	73.02	16.00	4.80	27.00	117.50	31.80	56.40	8.00
217	3 7/16	FC3U255N*Δ	7.375	8 5/8	2 13/32	10 1/4	3 9/16	3/4	-	1 5/8	5 3/16	1 5/32	2 25/32	34.00
	3 1/2	FC3U2E56N*Δ												
	85.00	FC3U2M85N*Δ	187.320	219.08	61.10	260.40	90.49	20.00	-	41.30	131.80	29.40	70.60	15.30
220	3 15/16	FC3U263N*	8.120	9 3/8	3 1/8	10 7/8	4 1/4	3/4	-	2 1/8	5 15/16	1 1/8	3 9/16	41.80
	4	FC3U2E64N*												
	100.00	FC3U2M100N*	206.250	238.12	79.40	276.20	107.95	20.00	-	54.00	150.80	28.60	90.50	18.80

Additional Notes

Please call 1-866-REXNORD for availability
 Lubrication fitting tap size: for size codes 206 and below, 1/4 in-28 UNF; for all other size codes, 1/8 in PT
 Pilot Diameter tolerance, +.000 in/-.002 in (+0.00 mm/-0.05 mm)
 Bore tolerance for mounting, +.002 in/-.000 in (+0.05 mm/-0.00 mm)
 Size codes 203 to 212 don't have mounting collars
 * N lip seals standard

■ Available with H labyrinth seals
 Δ Available with E3 triple lip seals
 For the Selection Guide, Load Ratings and Speed Limits, see the Link-Belt 200 Series Ball Bearing Engineering section on pages 290 - 298.
 Note: Dimensions subject to change. Certified dimensions of ordered material furnished on request.

FC3S200

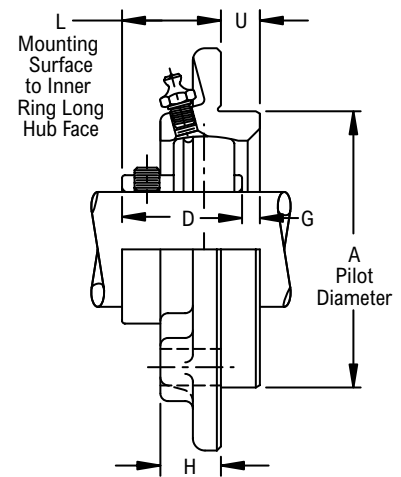
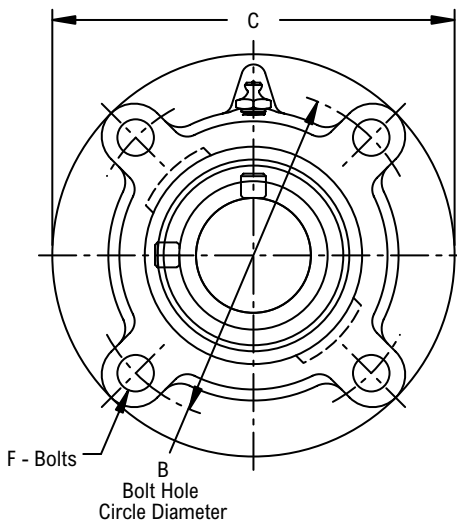
Interchange: FCVSC



Photo Shows a 4-Bolt Ball Bearing Flanged Cartridge Unit

Product Features

- Corrosion-resistant powder coating
- Cast iron housing
- Broad range of sealing options
- Spring locking setscrew mount
- Alignable & relubricatable
- See Features and Benefits for additional info on pages 286 - 287.



Bearing Dimensions

Size Code	Shaft Diameter	Part Number	A Pilot Diameter	B Bolt Hole Circle Diameter	L Mounting Surface to Inner Ring Long Hub Face	C	D	F Bolts	G	H	U	Approx. Weight
207	1 1/4	FC3S220E♦♦ □Δ	3.375	4 1/8	1 33/64	5	1 9/16	7/16	17/64	7/8	3/8	3.13
	1 3/8	FC3S222E♦♦ □Δ										3.03
	1 7/16	FC3S223E♦♦ □Δ										2.97
	35.00	FC3S2M35E♦♦ □Δ	85.720	104.78	38.50	127.00	39.67	10.00	6.80	22.20	9.50	1.40
208	1 1/2	FC3S224E♦♦ □Δ	3.625	4 3/8	1 17/32	5 1/4	1 21/32	7/16	1/4	7/8	7/16	3.63
	1 5/8	FC3S2E26E♦♦ □Δ										3.49
	40.00	FC3S2M40E♦♦ □Δ										92.080
209	1 5/8	FC3S226E♦♦ □Δ	3.625	4 3/8	1 37/64	5 1/4	1 49/64	7/16	3/16	7/8	7/16	3.76
	1 11/16	FC3S227E♦♦ □Δ										3.66
	1 3/4	FC3S228E♦♦ □Δ										3.59
210	1 7/8	FC3S230E♦♦ □Δ	4.250	5 1/8	1 19/32	6 1/8	1 13/16	1/2	13/64	7/8	15/32	4.97
	1 15/16	FC3S231E♦♦ □Δ										4.88
	2	FC3S2E32E♦♦ □Δ										4.79
211	2	FC3S232E♦♦ □Δ	4.500	5 3/8	1 35/64	6 3/8	1 13/16	1/2	19/64	7/8	5/8	5.87
	2 3/16	FC3S235E♦♦ □Δ										5.57
	2 1/4	FC3S2E36E♦♦ □Δ										5.47
212	2 1/4	FC3S236E♦♦ □Δ	5.000	6	1 11/16	7 1/8	1 57/64	9/16	37/64	1	7/8	8.40
	2 3/8	FC3S238E♦♦ □Δ										8.16
	2 7/16	FC3S239E♦♦ □Δ										8.04
215	2 15/16	FC3S247E♦♦ □Δ	6.375	7 1/2	1 23/32	8 3/4	2 17/64	5/8	25/64	1	1	13.44

Additional Notes

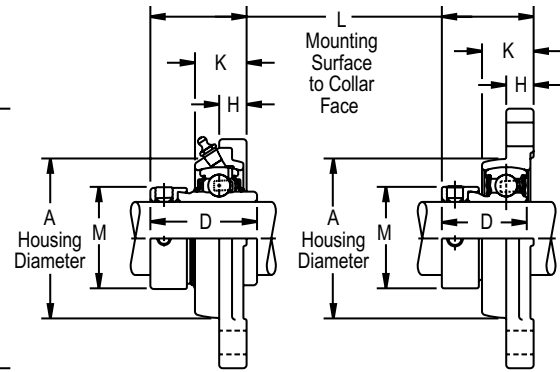
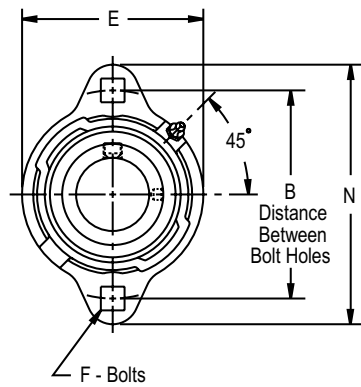
- Please call 1-866-REXNORD for availability
- Lubrication fitting tap size, 1/8 in PT
- Pilot Diameter tolerance, +.000 in/-.002 in (+0.00 mm/-0.05 mm)
- Bore tolerance for mounting, +.002 in/-.000 in (+0.05 mm/-0.00 mm)
- Lip seals standard
- ♦ Available with E1 viton seals for all size codes

Available with free running style seals, add suffix ♦ FF, □ HFF or Δ MHFF for all size codes For the Selection Guide, Load Ratings and Speed Limits, see the Link-Belt 200 Series Ball Bearing Engineering section on pages 290 - 298.
 Note: Dimensions subject to change. Certified dimensions of ordered material furnished on request.

FXYG200, FXYG200



Photo Shows a 2-Bolt Ball Bearing Flanged Unit with High Test Iron Housing



Product Features

- Corrosion-resistant powder coating
- High test iron housing
- Broad range of sealing options
- Wide inner ring for increased shaft stability
- Eccentric cam locking device
- Alignable & optional relubrication feature
- 2-bolt carriage outboard mounting
- See Features and Benefits for additional info on pages 286 - 287.

Bearing Dimensions

Size Code	Shaft Diameter	Non-Relubricatable		Relubricatable		A Housing Diameter	B Distance Between Bolt Holes	L Mounting Surface to Collar Face	D	F Bolts	H	K	M	N	Approx. Weight
		Part Number	E	Part Number	E										
203	1/2	FXY2B08N *■	2 3/16	FXYG2B08N *■	2 3/32	1 25/32	2 1/2	1 19/64	1 15/32	1/4	3/8	45/64	1 1/8	3 3/16	0.60
	5/8	FXY210N *■		FXYG210N *■											
	11/16	FXY211N *■		FXYG211N *■											
204	3/4	FXY212N *■	2 15/32	FXYG212N *■	2 3/8	2 1/16	2 13/16	1 15/32	1 23/32	5/16	27/64	25/32	1 5/16	3 9/16	0.80
	7/8	FXY214N *Δ■	2 23/32	FXYG214N *Δ■	2 5/8	2 9/32	3	1 31/64	1 3/4	5/16	27/64	25/32	1 1/2	3 3/4	1.00
15/16	FXY215N *Δ■	FXYG215N *Δ■													
1	FXY216N *Δ■	FXYG216N *Δ■													
206	1 1/8	FXY218N *Δ■	3 3/32	FXYG218N *Δ■	3 3/32	2 23/32	3 9/16	1 21/32	1 29/32	3/8	15/32	57/64	1 3/4	4 7/16	1.40
	1 3/16	FXY219N *Δ■		FXYG219N *Δ■											
	1 1/4	FXY2E20N *Δ■		FXYG2E20N *Δ■											
207	1 1/4	FXY220N *Δ■	3 1/2	FXYG220N *Δ■	3 1/2	3 1/8	3 15/16	1 25/32	2 1/64	3/8	1/2	15/16	2 3/16	4 13/16	2.00
	1 3/8	FXY222N *Δ■		FXYG222N *Δ■											
	1 7/16	FXY223N *Δ■		FXYG223N *Δ■											

Additional Notes

- Please call 1-866-REXNORD for availability
- Lubrication fitting tap size: for size codes 204 and below, 10-32 UNF; for all other size codes, 1/4 in-28 UNF
- Loading slots are on mounting face side for non-relubricatable units
- * N lip seals standard
- Available with H labyrinth seals

Δ Available with E3 triple lip seals

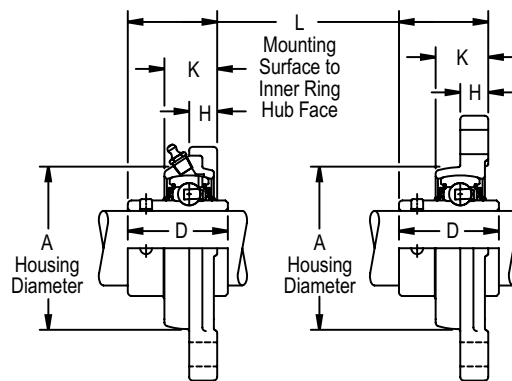
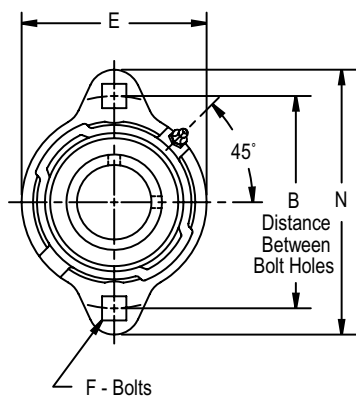
For the Selection Guide, Load Ratings and Speed Limits, see the Link-Belt 200 Series Ball Bearing Engineering section on pages 290 - 298.

Note: Dimensions subject to change. Certified dimensions of ordered material furnished on request.

FXU200, FXUG200



Photo Shows a 2-Bolt Ball Bearing Flanged Unit with High Test Iron Housing



Product Features

- Corrosion-resistant powder coating
- High test iron housing
- Broad range of sealing options
- Wide inner ring for increased shaft stability
- Spring locking setscrew mount
- Alignable & optional relubrication feature
- 2-bolt carriage outboard mounting
- See Features and Benefits for additional info on pages 286 - 287.

Bearing Dimensions

Size Code	Shaft Diameter	Non-Relubricatable		Relubricatable		A Housing Diameter	B Distance Between Bolt Holes	L Mounting Surface to Inner Ring Hub Face	D	F Bolts	H	K	N	Approx. Weight
		Part Number	E	Part Number	E									
203	1/2	FXU2B08N*■	2 3/16	FXUG2B08N*■	2 3/32	1 25/32	2 1/2	1 1/64	1 3/32	1/4	3/8	45/64	3 3/16	0.60
	5/8	FXU210N*■		FXUG210N*■										
	11/16	FXU211N*■		FXUG211N*■										
204	3/4	FXU212N*■	2 15/32	FXUG212N*■	2 3/8	2 1/16	2 13/16	1 11/64	1 9/32	5/16	27/64	25/32	3 9/16	0.80
205	7/8	FXU214N*Δ■	2 23/32	FXUG214N*Δ■	2 5/8	2 9/32	3	1 7/32	1 23/64	5/16	27/64	25/32	3 3/4	1.00
	15/16	FXU215N*Δ■		FXUG215N*Δ■										
	1	FXU216N*Δ■		FXUG216N*Δ■										
206	1 1/8	FXU218N*Δ■	3 3/32	FXUG218N*Δ■	3 3/32	2 23/32	3 9/16	1 27/64	1 9/16	3/8	15/32	57/64	4 7/16	1.40
	1 3/16	FXU219N*Δ■		FXUG219N*Δ■										
	1 1/4	FXU2E20N*Δ■		FXUG2E20N*Δ■										
207	1 1/4	FXU220N*Δ■	3 1/2	FXUG220N*Δ■	3 1/2	3 1/8	3 15/16	1 39/64	1 49/64	3/8	1/2	15/16	4 13/16	2.00
	1 3/8	FXU222N*Δ■		FXUG222N*Δ■										
	1 7/16	FXU223N*Δ■		FXUG223N*Δ■										

Additional Notes

- Please call 1-866-REXNORD for availability
- Lubrication fitting tap size: for size codes 204 and below, 10-32 UNF; for all other size codes, 1/4 in-28 UNF
- Loading slots are on mounting face side for non-relubricatable units
- * N lip seals standard
- Available with H labyrinth seals

- Δ Available with E3 triple lip seals
- For the Selection Guide, Load Ratings and Speed Limits, see the Link-Belt 200 Series Ball Bearing Engineering section on pages 290 - 298.
- Note: Dimensions subject to change. Certified dimensions of ordered material furnished on request.

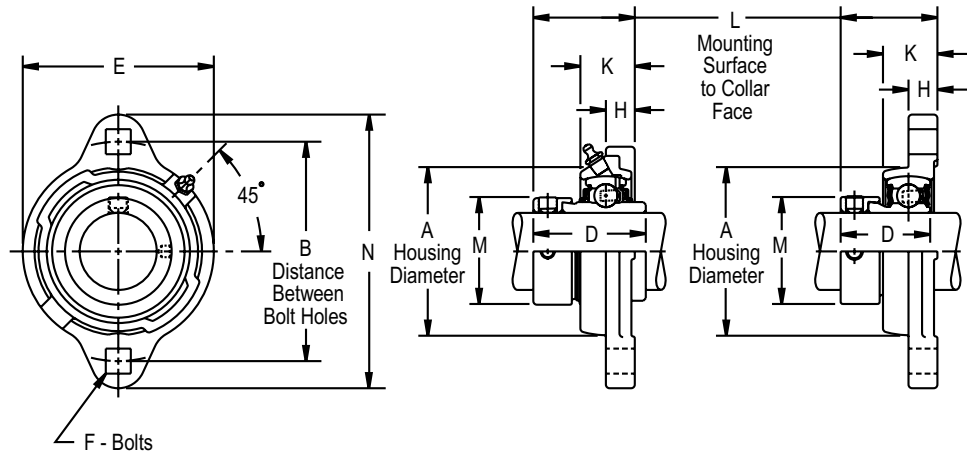
FXW200, FXWG200



Photo Shows a 2-Bolt Ball Bearing Flanged Unit with High Test Iron Housing

Product Features

- Corrosion-resistant powder coating
- High test iron housing
- Eccentric cam locking device
- Alignable & optional relubrication feature
- 2-bolt carriage outboard mounting
- See Features and Benefits for additional info on pages 286 - 287.



Bearing Dimensions

Size Code	Shaft Diameter	Non-Relubricatable		Relubricatable		A Housing Diameter	B Distance Between Bolt Holes	L Mounting Surface to Collar Face	D	F Bolts	H	K	M	N	Approx. Weight
		Part Number	E	Part Number	E										
203	1/2	FXW2B08E▲	2 3/16	FXWG2B08E▲	2 3/32	1 25/32	2 1/2	1 1/4	1 1/8	1/4	3/8	45/64	1 1/8	3 3/16	0.50
	5/8	FXW210E▲		FXWG210E▲											
204	3/4	FXW212E▲	2 15/32	FXWG212E▲	2 3/8	2 1/16	2 13/16	1 11/32	1 7/32	5/16	27/64	25/32	1 5/16	3 9/16	0.70
	7/8	FXW214E▲		FXWG214E▲											
205	15/16	FXW215E▲	2 23/32	FXWG215E▲	2 5/8	2 9/32	3	1 11/32	1 7/32	5/16	27/64	25/32	1 1/2	3 3/4	0.80
	1	FXW216E▲		FXWG216E▲											
206	1 1/8	FXW218E▲	3 3/32	FXWG218E▲	3 3/32	2 23/32	3 9/16	1 17/32	1 13/32	3/8	15/32	57/64	1 3/4	4 7/16	1.20
	1 3/16	FXW219E▲		FXWG219E▲											
207	1 1/4	FXW220E▲	3 1/2	FXWG220E▲	3 1/2	3 1/8	3 15/16	1 21/32	1 17/32	3/8	1/2	15/16	2 3/16	4 13/16	1.80
	1 3/8	FXW222E▲		FXWG222E▲											
	1 7/16	FXW223E▲		FXWG223E▲											

Additional Notes

- Please call 1-866-REXNORD for availability
- Lubrication fitting tap size: for size codes 204 and below, 10-32 UNF; for all other size codes, 1/4 in-28 UNF
- Loading slots are on mounting face side for non-relubricatable units
- ▲ E lip seals standard

For the Selection Guide, Load Ratings and Speed Limits, see the Link-Belt 200 Series Ball Bearing Engineering section on pages 290 - 298.
 Note: Dimensions subject to change. Certified dimensions of ordered material furnished on request.

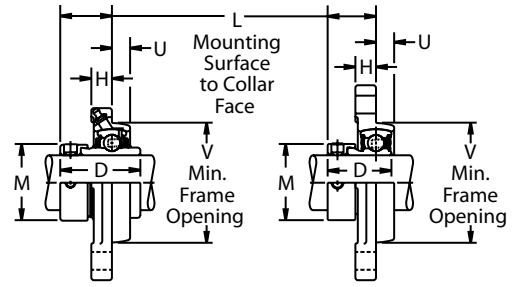
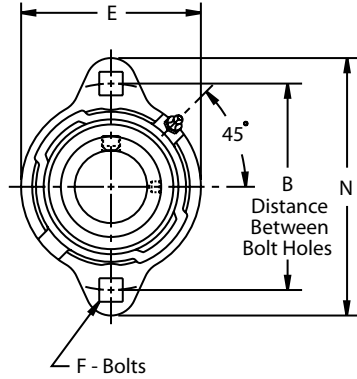
FXRY200, FXRYG200



Photo Shows a 2-Bolt Ball Bearing Flanged Unit with High Test Iron Housing

Product Features

- Corrosion-resistant powder coating
- High test iron housing
- Broad range of sealing options
- Wide inner ring for increased shaft stability
- Eccentric cam locking device
- Alignable & optional relubrication feature
- 2-bolt carriage inboard mounting
- See Features and Benefits for additional info on pages 286 - 287.



Bearing Dimensions

Size Code	Shaft Diameter	Non-Relubricatable	Relubricatable	B Distance Between Bolt Holes	L Mounting Surface to Collar Face	V Frame Opening	D	E	F Bolts	H	M	N	U	Approx. Weight
		Part Number	Part Number											
203	1/2	FXRY2B08N*■	FXRYG2B08N*■	2 1/2	59/64	1 7/8	1 15/32	2 3/16	1/4	3/8	1 1/8	3 3/16	2 1/64	0.60
	5/8	FXRY210N*■	FXRYG210N*■											
	11/16	FXRY211N*■	FXRYG211N*■											
204	3/4	FXRY212N*■	FXRYG212N*■	2 13/16	1 3/64	2 5/32	1 23/32	2 15/32	5/16	27/64	1 5/16	3 9/16	23/64	0.80
205	7/8	FXRY214N*Δ	FXRYG214N*Δ	3	1 1/16	2 3/8	1 3/4	2 23/32	5/16	27/64	1 1/2	3 3/4	23/64	1.00
	15/16	FXRY215N*Δ	FXRYG215N*Δ											
	1	FXRY216N*Δ	FXRYG216N*Δ											
206	1 1/8	FXRY218N*Δ	FXRYG218N*Δ	3 9/16	1 3/16	2 13/16	1 29/32	3 3/32	3/8	15/32	1 3/4	4 7/16	27/64	1.40
	1 3/16	FXRY219N*Δ	FXRYG219N*Δ											
	1 1/4	FXRY2E20N*Δ	FXRYG2E20N*Δ											
207	1 1/4	FXRY220N*Δ	FXRYG220N*Δ	3 15/16	1 9/32	3 7/32	2 1/64	3 1/2	3/8	1/2	2 3/16	4 13/16	7/16	2.00
	1 3/8	FXRY222N*Δ	FXRYG222N*Δ											
	1 7/16	FXRY223N*Δ	FXRYG223N*Δ											

Additional Notes

- Please call 1-866-REXNORD for availability
- Lubrication fitting tap size: for size codes 204 and below, 10-32 UNF: for all other size codes, 1/4 in-28 UNF
- Short shank square neck carriage bolt is not recommended
- * N lip seals standard
- Available with H labyrinth seals

- Δ Available with E3 triple lip seals
- For the Selection Guide, Load Ratings and Speed Limits, see the Link-Belt 200 Series Ball Bearing Engineering section on pages 290 - 298.
- Note: Dimensions subject to change. Certified dimensions of ordered material furnished on request.

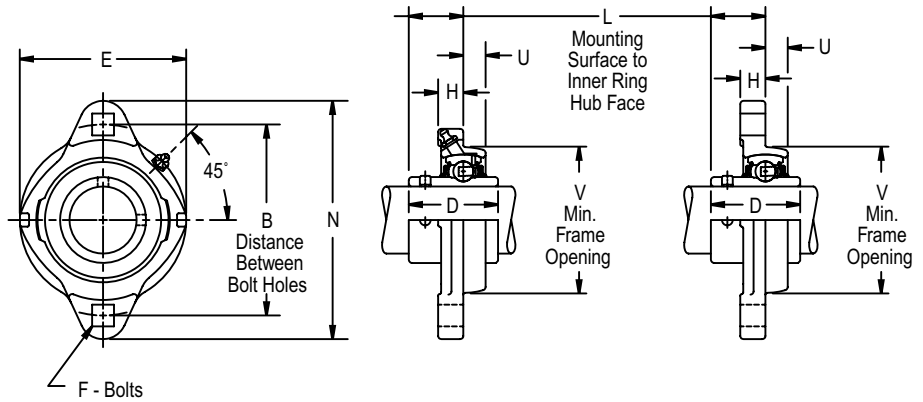
FXRU200, FXRUG200



Photo Shows a 2-Bolt Ball Bearing Flanged Unit with High Test Iron Housing

Product Features

- Corrosion-resistant powder coating
- High test iron housing
- Broad range of sealing options
- Wide inner ring for increased shaft stability
- Spring locking setscrew mount
- Alignable & optional relubrication feature
- 2-bolt carriage inboard mounting
- See Features and Benefits for additional info on pages 286 - 287.



Bearing Dimensions

Size Code	Shaft Diameter	Non-Relubricatable	Relubricatable	B Distance Between Bolt Holes	L Mounting Surface to Inner Ring Hub Face	V Frame Opening	D	E	F Bolts	H	N	U	Approx. Weight
		Part Number	Part Number										
203	1/2	FXRU2B08N*■	FXRUG2B08N*■	2 1/2	41/64	1 7/8	1 3/32	2 3/16	1/4	3/8	3 3/16	21/64	0.60
	5/8	FXRU210N*■	FXRUG210N*■										
	11/16	FXRU211N*■	FXRUG211N*■										
204	3/4	FXRU212N*■	FXRUG212N*■	2 13/16	3/4	2 5/32	1 9/32	2 15/32	5/16	27/64	3 9/16	23/64	0.80
205	7/8	FXRU214N*Δ■	FXRUG214N*Δ■	3	51/64	2 3/8	1 23/64	2 23/32	5/16	27/64	3 3/4	23/64	1.00
	15/16	FXRU215N*Δ■	FXRUG215N*Δ■										
	1	FXRU216N*Δ■	FXRUG216N*Δ■										
206	1 1/8	FXRU218N*Δ■	FXRUG218N*Δ■	3 9/16	61/64	2 13/16	1 9/16	3 3/32	3/8	15/32	4 7/16	27/64	1.40
	1 3/16	FXRU219N*Δ■	FXRUG219N*Δ■										
	1 1/4	FXRU2E20N*Δ■	FXRUG2E20N*Δ■										
207	1 1/4	FXRU220N*Δ■	FXRUG220N*Δ■	3 15/16	1 7/64	3 7/32	1 49/64	3 1/2	3/8	1/2	4 13/16	7/16	2.00
	1 3/8	FXRU222N*Δ■	FXRUG222N*Δ■										
	1 7/16	FXRU223N*Δ■	FXRUG223N*Δ■										

Additional Notes

- Please call 1-866-REXNORD for availability
- Lubrication fitting tap size: for size codes 204 and below, 10-32 UNF; for all other size codes, 1/4 in-28 UNF
- Short shank square neck carriage bolt is not recommended
- * N lip seals standard
- Available with H labyrinth seals

Δ Available with E3 triple lip seals

For the Selection Guide, Load Ratings and Speed Limits, see the Link-Belt 200 Series Ball Bearing Engineering section on pages 290 - 298.

Note: Dimensions subject to change. Certified dimensions of ordered material furnished on request.

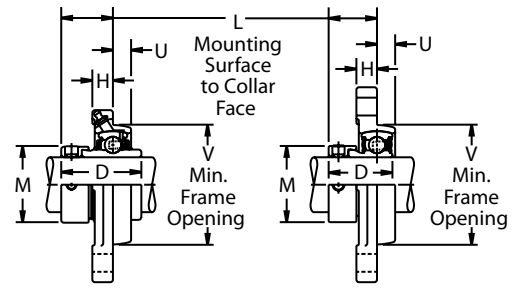
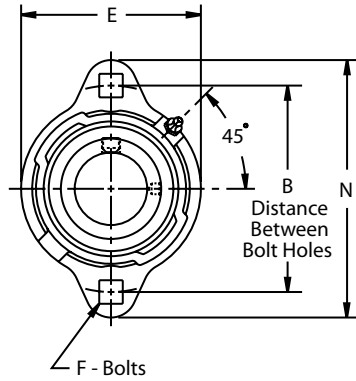
FXRW200, FXRWG200



Photo Shows a 2-Bolt Ball Bearing Flanged Unit with High Test Iron Housing

Product Features

- Corrosion-resistant powder coating
- High test iron housing
- Eccentric cam locking device
- Alignable & optional relubrication feature
- 2-bolt carriage inboard mounting
- See Features and Benefits for additional info on pages 286 - 287.



Bearing Dimensions

Size Code	Shaft Diameter	Non-Relubricatable	Relubricatable	B Distance Between Bolt Holes	L Mounting Surface to Collar Face	V Frame Opening	D	E	F Bolts	H	M	N	U	Approx. Weight
		Part Number	Part Number											
203	1/2	FXRW2B08E▲	FXRWG2B08E▲	2 1/2	7/8	1 7/8	1 1/8	2 3/16	1/4	3/8	1 1/8	3 3/16	21/64	0.50
	5/8	FXRW210E▲	FXRWG210E▲											
204	3/4	FXRW212E▲	FXRWG212E▲	2 13/16	59/64	2 5/32	1 7/32	2 15/32	5/16	27/64	1 5/16	3 9/16	23/64	0.70
205	7/8	FXRW214E▲	FXRWG214E▲	3	59/64	2 3/8	1 7/32	2 23/32	5/16	27/64	1 1/2	3 3/4	23/64	0.80
	15/16	FXRW215E▲	FXRWG215E▲											
	1	FXRW216E▲	FXRWG216E▲											
206	1 1/8	FXRW218E▲	FXRWG218E▲	3 9/16	1 3/64	2 13/16	1 13/32	3 3/32	3/8	15/32	1 3/4	4 7/16	27/64	1.20
	1 3/16	FXRW219E▲	FXRWG219E▲											
	1 1/4	FXRW220E▲	FXRWG220E▲											
207	1 1/4	FXRW220E▲	FXRWG220E▲	3 15/16	1 5/32	3 7/32	1 17/32	3 1/2	3/8	1/2	2 3/16	4 13/16	7/16	1.80
	1 3/8	FXRW222E▲	FXRWG222E▲											
	1 7/16	FXRW223E▲	FXRWG223E▲											

Additional Notes

- Please call 1-866-REXNORD for availability
- Lubrication fitting tap size: for size codes 204 and below, 10-32 UNF: for all other size codes, 1/4 in-28 UNF
- Short shank square neck carriage bolt is not recommended
- ▲ E lip seals standard

For the Selection Guide, Load Ratings and Speed Limits, see the Link-Belt 200 Series Ball Bearing Engineering section on pages 290 - 298.
 Note: Dimensions subject to change. Certified dimensions of ordered material furnished on request.

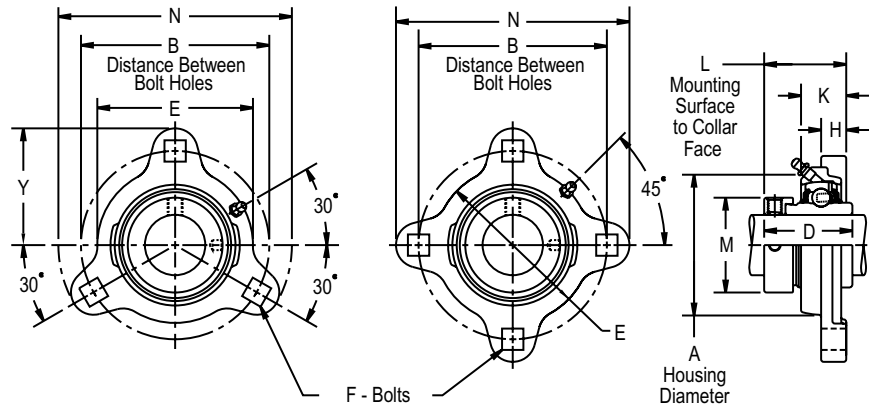
FY200, FYG200



Photo Shows a 3-Bolt Ball Bearing Flanged Unit with High Test Iron Housing

Product Features

- Corrosion-resistant powder coating
- High test iron housing
- Broad range of sealing options
- Wide inner ring for increased shaft stability
- Eccentric cam locking device
- Alignable & optional relubrication feature
- 3 or 4-bolt carriage outboard mounting
- See Features and Benefits for additional info on pages 286 - 287.



Bearing Dimensions

Size Code	Shaft Diameter	Non-Relubricatable		Relubricatable		B Distance Between Bolt Holes	L Mounting Surface to Collar Face	D	E	F Bolts	H	K	M	N	Y	Approx. Weight
		Part Number	A Housing Diameter	Part Number	A Housing Diameter											
3-Bolt																
203	1/2	FY2B08N*■	1 25/32	FYG2B08N*■	1 29/32	2 1/2	1 19/64	1 15/32	2 3/32	1/4	3/8	45/64	1 1/8	3 3/16	1 19/32	0.60
	5/8	FY210N*■		FYG210N*■												
	11/16	FY211N*■		FYG211N*■												
204	3/4	FY212N*■	2 1/16	FYG212N*■	2 3/16	2 13/16	1 15/32	1 23/32	2 3/8	5/16	27/64	25/32	1 5/16	3 9/16	1 25/32	0.80
	7/8	FY214N*Δ■		FYG214N*Δ■												
205	15/16	FY215N*Δ■	2 9/32	FYG215N*Δ■	2 3/8	3	1 31/64	1 3/4	2 5/8	5/16	27/64	25/32	1 1/2	3 3/4	1 7/8	1.00
	1	FY216N*Δ■		FYG216N*Δ■												
	1 1/8	FY218N*Δ■		FYG218N*Δ■												
206	1 3/16	FY219N*Δ■	2 23/32	FYG219N*Δ■	2 13/16	3 9/16	1 21/32	1 29/32	3 3/32	3/8	15/32	57/64	1 3/4	4 7/16	2 7/32	1.40
	1 1/4	FY2E20N*Δ■		FYG2E20N*Δ■												
	1 1/4	FY220N*Δ■		FYG220N*Δ■												
207	1 3/8	FY222N*Δ■	3 1/8	FYG222N*Δ■	3 7/32	3 15/16	1 25/32	2 1/64	3 1/2	3/8	1/2	15/16	2 3/16	4 13/16	2 13/32	2.00
	1 7/16	FY223N*Δ■		FYG223N*Δ■												
4-Bolt																
208	1 1/2	FY224N*Δ■	3 15/32	FYG224N*Δ■	3 21/32	4 11/16	2	2 7/32	3 7/8	1/2	5/8	1 1/8	2 3/8	5 13/16	-	3.00
	1 5/8	FY226N*Δ■		FYG226N*Δ■												
209	1 11/16	FY227N*Δ■	3 11/16	FYG227N*Δ■	3 13/16	4 3/4	2	2 7/32	4 7/32	1/2	5/8	1 1/8	2 1/2	5 7/8	-	3.10
	1 3/4	FY228N*Δ■		FYG228N*Δ■												
210	1 15/16	FY231N*Δ■	3 7/8	FYG231N*Δ■	4 1/16	5	2 1/8	2 15/32	4 15/32	1/2	5/8	1 1/8	2 3/4	6 1/8	-	3.60
	2	FY2E32N*Δ■		FYG2E32N*Δ■												

Additional Notes

- Please call 1-866-REXNORD for availability
- Lubrication fitting tap size: for size codes 204 and below, 10-32 UNF; for all other size codes, 1/4 in-28 UNF
- Loading slots are on mounting face side for non-relubricatable units
- * N lip seals standard
- Available with H labyrinth seals

Δ Available with E3 triple lip seals

For the Selection Guide, Load Ratings and Speed Limits, see the Link-Belt 200 Series Ball Bearing Engineering section on pages 290 - 298.

Note: Dimensions subject to change. Certified dimensions of ordered material furnished on request.

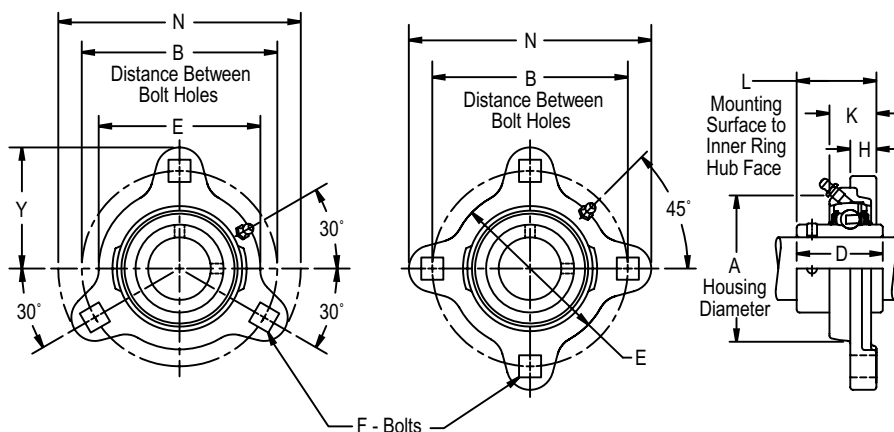
FU200, FUG200



Photo Shows a 3-Bolt Ball Bearing Flanged Unit with High Test Iron Housing

Product Features

- Corrosion-resistant powder coating
- High test iron housing
- Broad range of sealing options
- Wide inner ring for increased shaft stability
- Spring locking setscrew mount
- Alignable & optional relubrication feature
- 3 or 4-bolt carriage outboard mounting
- See Features and Benefits for additional info on pages 286 - 287.



Bearing Dimensions

Size Code	Shaft Diameter	Non-Relubricatable		Relubricatable		B Distance Between Bolt Holes	L Mounting Surface to Inner Ring Hub Face	D	E	F Bolts	H	K	N	Y	Approx. Weight
		Part Number	A Housing Diameter	Part Number	A Housing Diameter										
3-Bolt															
203	1/2	FU2B08N*■	1 25/32	FUG2B08N*■	1 29/32	2 1/2	1 1/64	1 3/32	2 3/32	1/4	3/8	45/64	3 3/16	1 19/32	0.60
	5/8	FU210N*■		FUG210N*■											
	11/16	FU211N*■		FUG211N*■											
204	3/4	FU212N*■	2 1/16	FUG212N*■	2 3/16	2 13/16	1 11/64	1 9/32	2 3/8	5/16	27/64	25/32	3 9/16	1 25/32	0.80
	7/8	FU214N*■		FUG214N*■											
205	15/16	FU215N*Δ	2 9/32	FUG215N*Δ	2 3/8	3	1 7/32	1 23/64	2 5/8	5/16	27/64	25/32	3 3/4	1 7/8	1.00
	1	FU216N*Δ		FUG216N*Δ											
	1 1/8	FU218N*Δ		FUG218N*Δ											
206	1 3/16	FU219N*Δ	2 23/32	FUG219N*Δ	2 13/16	3 9/16	1 27/64	1 9/16	3 3/32	3/8	15/32	57/64	4 7/16	2 7/32	1.40
	1 1/4	FU2E20N*Δ		FUG2E20N*Δ											
	1 3/4	FU220N*Δ		FUG220N*Δ											
207	1 3/8	FU222N*Δ	3 1/8	FUG222N*Δ	3 7/32	3 15/16	1 39/64	1 49/64	3 1/2	3/8	1/2	15/16	4 13/16	2 13/32	2.00
	1 7/16	FU223N*Δ		FUG223N*Δ											
4-Bolt															
208	1 1/2	FU224N*Δ	3 15/32	FUG224N*Δ	3 21/32	4 11/16	1 51/64	1 29/32	3 7/8	1/2	5/8	1 1/8	5 13/16	-	3.00
	1 5/8	FU226N*Δ		FUG226N*Δ											
209	1 11/16	FU227N*Δ	3 11/16	FUG227N*Δ	3 13/16	4 3/4	1 55/64	2 1/32	4 7/32	1/2	5/8	1 1/8	5 7/8	-	3.10
	1 3/4	FU228N*Δ		FUG228N*Δ											
	1 15/16	FU231N*Δ		FUG231N*Δ											
210	2	FU2E32N*Δ	3 7/8	FUG2E32N*Δ	4 1/16	5	1 57/64	2 3/32	4 15/32	1/2	5/8	1 1/8	6 1/8	-	3.60

Additional Notes

- Please call 1-866-REXNORD for availability
- Lubrication fitting tap size: for size codes 204 and below, 10-32 UNF: for all other size codes, 1/4 in-28 UNF
- Loading slots are on mounting face side for non-relubricatable units
- * N lip seals standard
- Available with H labyrinth seals

- Δ Available with E3 triple lip seals
- For the Selection Guide, Load Ratings and Speed Limits, see the Link-Belt 200 Series Ball Bearing Engineering section on pages 290 - 298.
- Note: Dimensions subject to change. Certified dimensions of ordered material furnished on request.

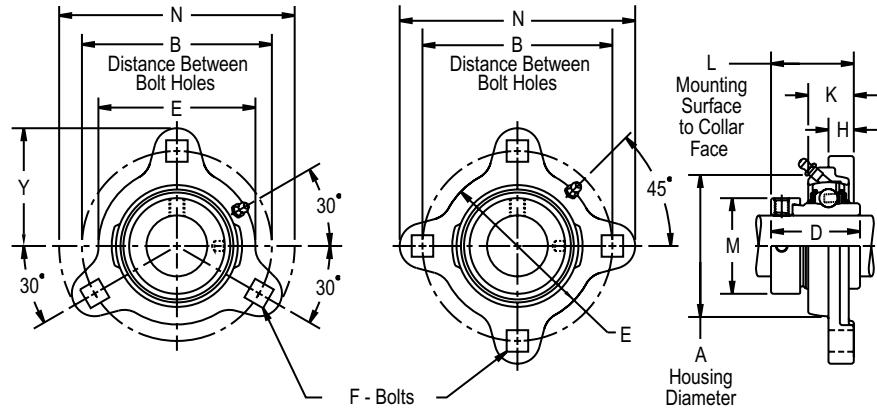
FW200, FWG200



Photo Shows a 3-Bolt Ball Bearing Flanged Unit with High Test Iron Housing

Product Features

- Corrosion-resistant powder coating
- High test iron housing
- Eccentric cam locking device
- Alignable & optional relubrication feature
- 3 or 4-bolt carriage outboard mounting
- See Features and Benefits for additional info on pages 286 - 287.



Bearing Dimensions

Size Code	Shaft Diameter	Non-Relubricatable		Relubricatable		B Distance Between Bolt Holes	L Mounting Surface to Collar Face	D	E	F Bolts	H	K	M	N	Y	Approx. Weight
		Part Number	A Housing Diameter	Part Number	A Housing Diameter											
3-Bolt																
203	1/2	FW2B08E▲	1 25/32	FWG2B08E▲	1 29/32	2 1/2	1 1/4	1 1/8	2 3/32	1/4	3/8	45/64	1 1/8	3 3/16	1 19/32	0.50
	5/8	FW210E▲		FWG210E▲												
204	3/4	FW212E▲	2 1/16	FWG212E▲	2 3/16	2 13/16	1 11/32	1 7/32	2 3/8	5/16	27/64	25/32	1 5/16	3 9/16	1 25/32	0.70
205	7/8	FW214E▲	2 9/32	FWG214E▲	2 3/8	3	1 11/32	1 7/32	2 5/8	5/16	27/64	25/32	1 1/2	3 3/4	1 7/8	0.80
	15/16	FW215E▲		FWG215E▲												
	1	FW216E▲		FWG216E▲												
206	1 1/8	FW218E▲	2 23/32	FWG218E▲	2 13/16	3 9/16	1 17/32	1 13/32	3 3/32	3/8	15/32	57/64	1 3/4	4 7/16	2 7/32	1.20
	1 3/16	FW219E▲		FWG219E▲												
	1 1/4	FW2E20E▲		FWG2E20E▲												
207	1 1/4	FW220E▲	3 1/8	FWG220E▲	3 7/32	3 15/16	1 21/32	1 17/32	3 1/2	3/8	1/2	7/8	2 3/16	4 13/16	2 13/32	1.80
	1 3/8	FW222E▲		FWG222E▲												
	1 7/16	FW223E▲		FWG223E▲												
4-Bolt																
208	1 1/2	FW224E▲	3 15/32	FWG224E▲	3 21/32	4 11/16	1 29/32	1 23/32	3 7/8	1/2	5/8	1 1/8	2 3/8	5 13/16	-	2.80
	1 5/8	FW226E▲		FWG226E▲												
209	1 11/16	FW227E▲	3 11/16	FWG227E▲	3 13/16	4 3/4	1 29/32	1 23/32	4 7/32	1/2	5/8	1 1/8	2 1/2	5 7/8	-	2.90
	1 3/4	FW228E▲		FWG228E▲												
210	1 15/16	FW231E▲	3 7/8	FWG231E▲	4 1/16	5	1 29/32	1 23/32	4 15/32	1/2	5/8	1 1/8	2 3/4	6 1/8	-	3.10
	2	FW2E32E▲		FWG2E32E▲												

Additional Notes

- Please call 1-866-REXNORD for availability
- Lubrication fitting tap size: for size codes 204 and below, 10-32 UNF; for all other size codes, 1/4 in-28 UNF
- Loading slots are on mounting face side for non-relubricatable units
- ▲ E lip seals standard

For the Selection Guide, Load Ratings and Speed Limits, see the Link-Belt 200 Series Ball Bearing Engineering section on pages 290 - 298.
 Note: Dimensions subject to change. Certified dimensions of ordered material furnished on request.

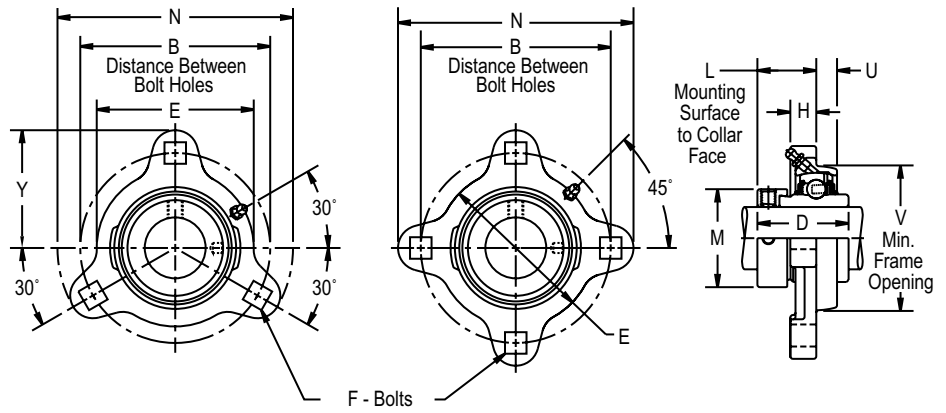
FRY200, FRYG200



Photo Shows a 3-Bolt Ball Bearing Flanged Unit with High Test Iron Housing

Product Features

- Corrosion-resistant powder coating
- High test iron housing
- Broad range of sealing options
- Wide inner ring for increased shaft stability
- Eccentric cam locking device
- Alignable & optional relubrication feature
- 3 or 4-bolt carriage inboard mounting
- See Features and Benefits for additional info on pages 286 - 287.



Bearing Dimensions

Size Code	Shaft Diameter	Non-Relubricatable	Relubricatable	B Distance Between Bolt Holes	L Mounting Surface to Collar Face	V Frame Opening	D	E	F Bolts	H	M	N	U	Y	Approx. Weight
		Part Number	Part Number												
3-Bolt															
203	1/2	FRY2B08N*■	FRYG2B08N*■	2 1/2	59/64	1 7/8	1 15/32	2 3/32	1/4	3/8	1 1/8	3 3/16	21/64	1 19/32	0.60
	5/8	FRY210N*■	FRYG210N*■												
	11/16	FRY211N*■	FRYG211N*■												
204	3/4	FRY212N*■	FRYG212N*■	2 13/16	1 3/64	2 5/32	1 23/32	2 3/8	5/16	27/64	1 5/16	3 9/16	23/64	1 25/32	0.80
205	7/8	FRY214N*Δ	FRYG214N*Δ	3	1 1/16	2 3/8	1 3/4	2 5/8	5/16	27/64	1 1/2	3 3/4	23/64	1 7/8	1.00
	15/16	FRY215N*Δ	FRYG215N*Δ												
	1	FRY216N*Δ	FRYG216N*Δ												
206	1 1/8	FRY218N*Δ	FRYG218N*Δ	3 9/16	1 3/16	2 13/16	1 25/32	3 3/32	3/8	15/32	1 3/4	4 7/16	27/64	2 7/32	1.40
	1 3/16	FRY219N*Δ	FRYG219N*Δ												
	1 1/4	FRY2E20N*Δ	FRYG2E20N*Δ												
207	1 1/4	FRY220N*Δ	FRYG220N*Δ	3 15/16	1 9/32	3 7/32	2 1/64	3 1/2	3/8	1/2	2 3/16	4 13/16	7/16	2 13/32	2.00
	1 3/8	FRY222N*Δ	FRYG222N*Δ												
	1 7/16	FRY223N*Δ	FRYG223N*Δ												
4-Bolt															
208	1 1/2	FRY224N*Δ	FRYG224N*Δ	4 11/16	1 3/8	3 9/16	2 7/32	3 7/8	1/2	5/8	2 3/8	5 13/16	1/2	-	3.00
	1 5/8	FRY226N*Δ	FRYG226N*Δ												
209	1 11/16	FRY227N*Δ	FRYG227N*Δ	4 3/4	1 3/8	3 25/32	2 7/32	4 7/32	1/2	5/8	2 1/2	5 7/8	1/2	-	3.10
	1 3/4	FRY228N*Δ	FRYG228N*Δ												
210	1 15/16	FRY231N*Δ	FRYG231N*Δ	5	1 1/2	3 31/32	2 15/32	4 15/32	1/2	5/8	2 3/4	6 1/8	1/2	-	3.60
	2	FRY2E32N*Δ	FRYG2E32N*Δ												

Additional Notes

- Please call 1-866-REXNORD for availability
- Lubrication fitting tap size: for size codes 204 and below, 10-32 UNF: for all other size codes, 1/4 in-28 UNF
- Short shank square neck carriage bolt is not recommended
- * N lip seals standard
- Available with H labyrinth seals

- Δ Available with E3 triple lip seals
- For the Selection Guide, Load Ratings and Speed Limits, see the Link-Belt 200 Series Ball Bearing Engineering section on pages 290 - 298.
- Note: Dimensions subject to change. Certified dimensions of ordered material furnished on request.

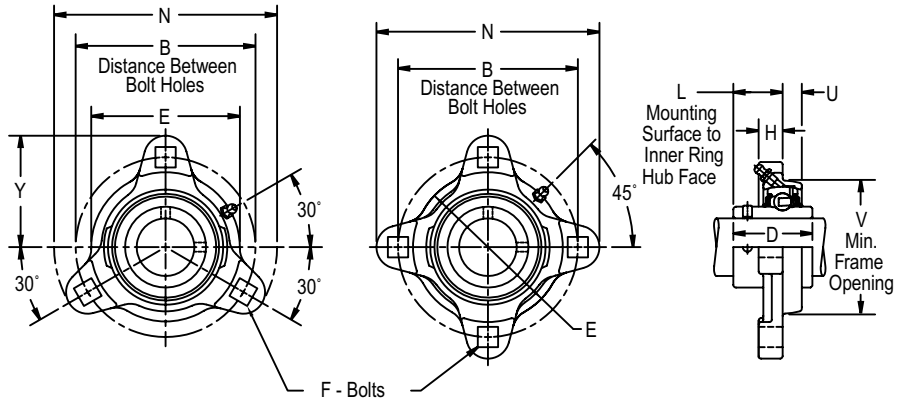
FRU200, FRUG200



Photo Shows a 3-Bolt Ball Bearing Flanged Unit with High Test Iron Housing

Product Features

- Corrosion-resistant powder coating
- High test iron housing
- Broad range of sealing options
- Wide inner ring for increased shaft stability
- Spring locking setscrew mount
- Alignable & optional relubrication feature
- 3 or 4-bolt carriage inboard mounting
- See Features and Benefits for additional info on pages 286 - 287.



Bearing Dimensions

Size Code	Shaft Diameter	Non-Relubricatable	Relubricatable	B Distance Between Bolt Holes	L Mounting Surface to Inner Ring Hub Face	V Frame Opening	D	E	F Bolts	H	N	U	Y	Approx. Weight
		Part Number	Part Number											
3-Bolt														
203	1/2	FRU2B08N*■	FRUG2B08N*■	2 1/2	4 1/64	1 7/8	1 3/32	2 3/32	1/4	3/8	3 3/16	2 1/64	1 19/32	0.60
	5/8	FRU210N*■	FRUG210N*■											
	11/16	FRU211N*■	FRUG211N*■											
204	3/4	FRU212N*■	FRUG212N*■	2 13/16	3/4	2 5/32	1 9/32	2 3/8	5/16	2 1/64	3 9/16	2 3/64	1 25/32	0.80
	7/8	FRU214N*Δ■	FRUG214N*Δ■											
205	15/16	FRU215N*Δ■	FRUG215N*Δ■	3	5 1/64	2 3/8	1 23/64	2 5/8	5/16	2 7/64	3 3/4	2 3/64	1 7/8	1.00
	1	FRU216N*Δ■	FRUG216N*Δ■											
	1 1/8	FRU218N*Δ■	FRUG218N*Δ■											
206	1 3/16	FRU219N*Δ■	FRUG219N*Δ■	3 9/16	6 1/64	2 13/16	1 9/16	3 3/32	3/8	1 5/32	4 7/16	2 7/64	2 7/32	1.40
	1 1/4	FRU2E20N*Δ■	FRUG2E20N*Δ■											
	1 1/4	FRU220N*Δ■	FRUG220N*Δ■											
207	1 3/8	FRU222N*Δ■	FRUG222N*Δ■	3 15/16	1 7/64	3 7/32	1 49/64	3 1/2	3/8	1/2	4 13/16	7/16	2 13/32	2.00
	1 7/16	FRU223N*Δ■	FRUG223N*Δ■											
4-Bolt														
208	1 1/2	FRU224N*Δ■	FRUG224N*Δ■	4 11/16	1 11/64	3 9/16	1 29/32	3 7/8	1/2	5/8	5 13/16	1/2	-	3.00
	1 5/8	FRU226N*Δ■	FRUG226N*Δ■											
209	1 11/16	FRU227N*Δ■	FRUG227N*Δ■	4 3/4	1 15/64	3 25/32	2 1/32	4 7/32	1/2	5/8	5 7/8	1/2	-	3.10
	1 3/4	FRU228N*Δ■	FRUG228N*Δ■											
210	1 15/16	FRU231N*Δ■	FRUG231N*Δ■	5	1 17/64	3 31/32	2 3/32	4 15/32	1/2	5/8	6 1/8	1/2	-	3.60
	2	FRU2E32N*Δ■	FRUG2E32N*Δ■											

Additional Notes

- Please call 1-866-REXNORD for availability
- Lubrication fitting tap size: for size codes 204 and below, 10-32 UNF; for all other size codes, 1/4 in-28 UNF
- Short shank square neck carriage bolt is not recommended
- * N lip seals standard
- Available with H labyrinth seals

Δ Available with E3 triple lip seals

For the Selection Guide, Load Ratings and Speed Limits, see the Link-Belt 200 Series Ball Bearing Engineering section on pages 290 - 298.

Note: Dimensions subject to change. Certified dimensions of ordered material furnished on request.

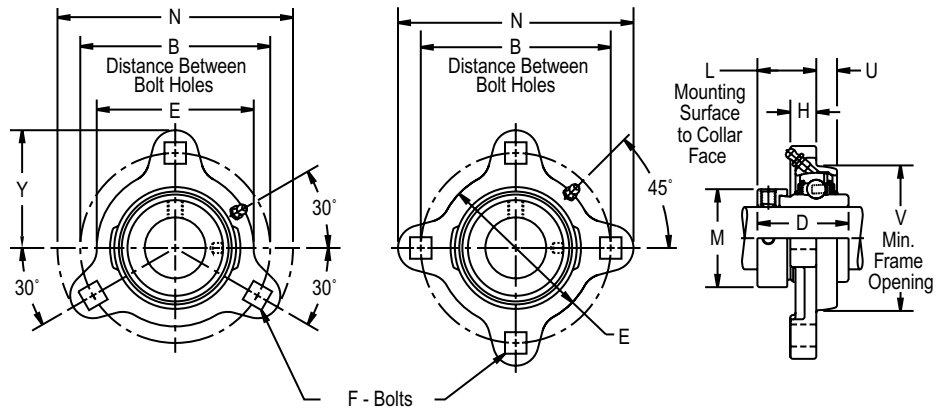
FRW200, FRWG200



Photo Shows a 3-Bolt Ball Bearing Flanged Unit with High Test Iron Housing

Product Features

- Corrosion-resistant powder coating
- High test iron housing
- Eccentric cam locking device
- Alignable & optional relubrication feature
- 3 or 4-bolt carriage inboard mounting
- See Features and Benefits for additional info on pages 286 - 287.



Bearing Dimensions

Size Code	Shaft Diameter	Non-Relubricatable	Relubricatable	B Distance Between Bolt Holes	L Mounting Surface to Collar Face	V Frame Opening	D	E	F Bolts	H	M	N	U	Y	Approx. Weight
		Part Number	Part Number												
3-Bolt															
203	1/2	FRW2B08E▲	FRWG2B08E▲	2 1/2	7/8	1 7/8	1 1/8	2 3/32	1/4	3/8	1 1/8	3 3/16	21/64	1 19/32	0.50
	5/8	FRW210E▲	FRWG210E▲												
204	3/4	FRW212E▲	FRWG212E▲	2 13/16	59/64	2 5/32	1 7/32	2 3/8	5/16	27/64	1 5/16	3 3/16	23/64	1 25/32	0.70
205	7/8	FRW214E▲	FRWG214E▲	3	59/64	2 3/8	1 7/32	2 5/8	5/16	27/64	1 1/2	3 3/4	23/64	1 7/8	0.80
	15/16	FRW215E▲	FRWG215E▲												
206	1	FRW216E▲	FRWG216E▲	3 9/16	1 3/64	2 13/16	1 13/32	3 3/32	3/8	15/32	1 3/4	4 7/16	27/64	2 7/32	1.20
	1 1/8	FRW218E▲	FRWG218E▲												
	1 3/16	FRW219E▲	FRWG219E▲												
207	1 1/4	FRW2E20E▲	FRWG2E20E▲	3 15/16	1 5/32	3 7/32	1 17/32	3 1/2	3/8	1/2	2 3/16	4 13/16	7/16	2 13/32	1.80
	1 1/4	FRW220E▲	FRWG220E▲												
	1 3/8	FRW222E▲	FRWG222E▲												
	1 7/16	FRW223E▲	FRWG223E▲												
4-Bolt															
208	1 1/2	FRW224E▲	FRWG224E▲	4 11/16	1 9/32	3 9/16	1 23/32	3 7/8	1/2	5/8	2 3/8	5 13/16	1/2	-	2.80
209	1 5/8	FRW226E▲	FRWG226E▲	4 3/4	1 9/32	3 25/32	1 23/32	4 7/32	1/2	5/8	2 1/2	5 7/8	1/2	-	2.90
	1 11/16	FRW227E▲	FRWG227E▲												
	1 3/4	FRW228E▲	FRWG228E▲												
210	1 15/16	FRW231E▲	FRWG231E▲	5	1 9/32	3 31/32	1 23/32	4 15/32	1/2	5/8	2 3/4	6 1/8	1/2	-	3.10
	2	FRW2E32E▲	FRWG2E32E▲												

Additional Notes

- Please call 1-866-REXNORD for availability
- Lubrication fitting tap size: for size codes 204 and below, 10-32 UNF: for all other size codes, 1/4 in-28 UNF
- Short shank square neck carriage bolt is not recommended
- ▲ E lip seals standard

For the Selection Guide, Load Ratings and Speed Limits, see the Link-Belt 200 Series Ball Bearing Engineering section on pages 290 - 298.
 Note: Dimensions subject to change. Certified dimensions of ordered material furnished on request.

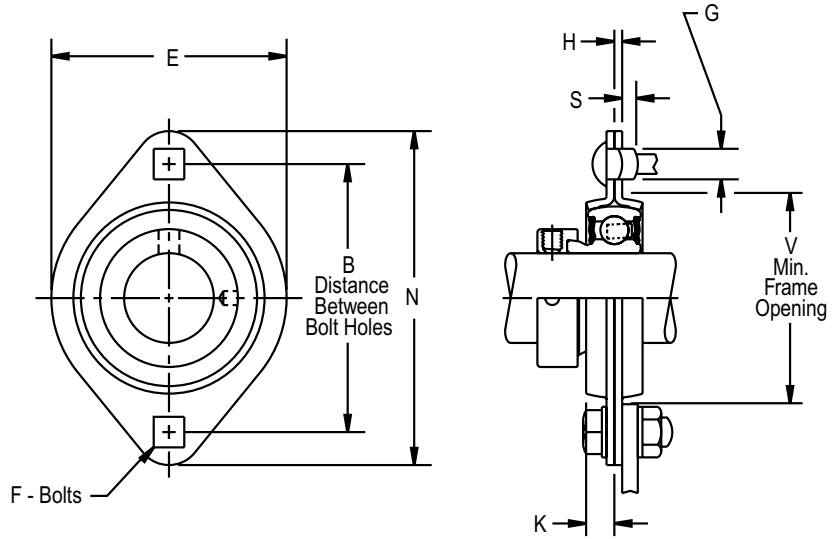
MST



Photo Shows an Formed Steel 2-Bolt Flanged Housing Half

Product Features

- 2-piece formed steel housing
- For collar mounted, round, square or hex bore bearings
- Alignable & non-relubricatable
- 2-bolt carriage mounting
- Bearing not included
- See Features and Benefits for additional info on pages 286 - 287.



Bearing Dimensions

Size Code	Part Number	B Distance Between Bolt Holes	F - Bolts		V Frame Opening	E	G	H	K	N	S Carriage Bolt		Radial Load Rating	Approx. Weight
			Hole Size	Bolt Size							Short Shank	Long Shank		
203	40MST	2 1/2	9/32	1/4	1 15/16	2 5/16	13/32	0.075	9/32	3 3/16	0.006	0.100	600	0.10
204	47MST	2 13/16	11/32	5/16	2 3/16	2 5/8	1/2	0.083	5/16	3 9/16	0.021	0.115	700	0.20
205	52MST	3	11/32	5/16	2 3/8	2 51/64	1/2	0.083	11/32	3 3/4	0.021	0.115	800	0.20
206	62MST	3 9/16	13/32	3/8	2 13/16	3 5/16	19/32	0.104	11/32	4 7/16	0.011	0.104	1,100	0.20

Additional Notes

- Please call 1-866-REXNORD for availability
- Assembly requires two housing halves
- For bearing insert information, see Unmounted Replacement Bearings section on pages 379 - 398.
- Note: Dimensions subject to change. Certified dimensions of ordered material furnished on request.

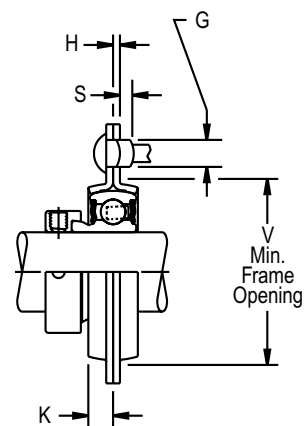
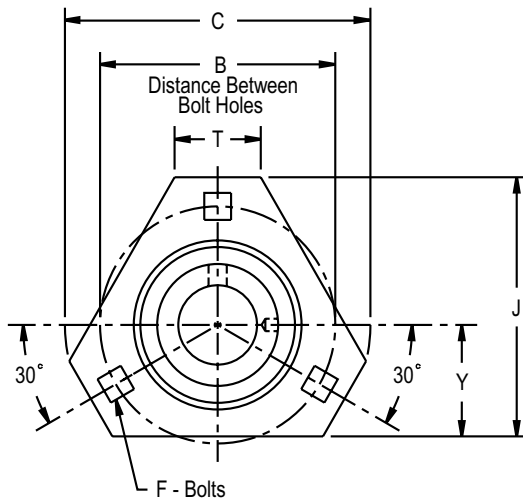
MSTR



Photo Shows a Formed Steel 3-Bolt Triangular Flanged Housing Half

Product Features

- 2-piece formed steel housing
- For collar mounted, round, square or hex bore bearings
- Alignable & non-relubricatable
- 3-bolt carriage mounting
- Bearing not included
- See Features and Benefits for additional info on pages 286 - 287.



Bearing Dimensions

Size Code	Part Number	B Distance Between Bolt Holes	F - Bolts		V Frame Opening	C	G	H	J	K	S Carriage Bolt		T	Y	Radial Load Rating	Approx. Weight
			Hole Size	Bolt Size							Short Shank	Long Shank				
204	47MSTR	2 13/16	11/32	5/16	2 3/16	3 9/16	1/2	0.083	3	5/16	0.021	0.115	1 1/16	1 5/16	700	0.25
205	52MSTR	3	11/32	5/16	2 3/8	3 3/4	1/2	0.083	3 5/32	11/32	0.021	0.115	1 7/64	1 3/8	800	0.50
206	62MSTR	3 9/16	13/32	3/8	2 13/16	4 7/16	19/32	0.104	3 11/16	11/32	0.011	0.104	3 1/32	1 1/2	1,100	0.50

Additional Notes

- Please call 1-866-REXNORD for availability
- Assembly requires two housing halves
- For bearing insert information, see Unmounted Replacement Bearings section on pages 379 - 398.
- Note: Dimensions subject to change. Certified dimensions of ordered material furnished on request.

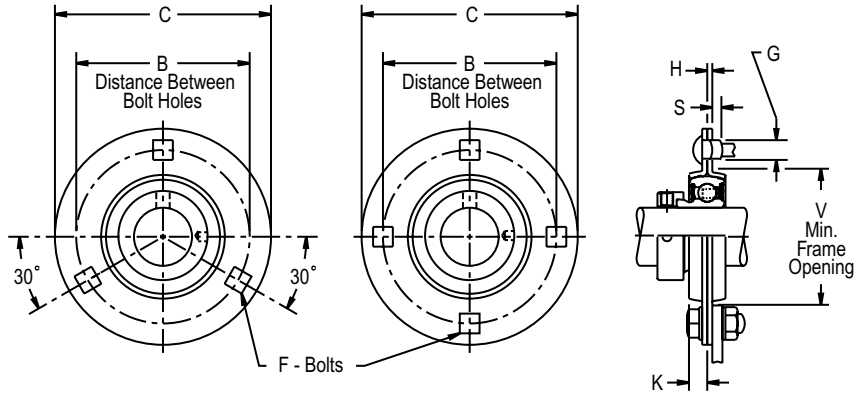
MS, MSC



Photo Shows a Formed Steel 3-Bolt or 4-Bolt Round Flanged Housing Half

Product Features

- 2-piece formed steel housing
- For collar mounted, round, square or hex bore bearings
- Alignable & non-relubricatable
- 3 or 4-bolt carriage mounting
- Bearing not included
- See Features and Benefits for additional info on pages 286 - 287.



Bearing Dimensions

Size Code	Part Number	B Distance Between Bolt Holes	F - Bolts		V Frame Opening	C	G	H	K	S Carriage Bolts		Radial Load Rating	Approx. Weight
			Hole Size	Bolt Size						Short Shank	Long Shank		
3-Bolt													
203	40MSC1	2 1/2	9/32	1/4	1 15/16	3 3/16	13/32	0.075	9/32	0.006	0.100	600	0.13
204	47MSC1	2 13/16	11/32	5/16	2 3/16	3 9/16	1/2	0.083	5/16	0.021	0.115	700	0.20
205	52MS2	3	11/32	5/16	2 3/8	3 3/4	1/2	0.104	11/32	0	0.073	1,100	0.30
	0.083							0.021		0.115	800		
206	62MSC1	3 9/16	13/32	3/8	2 13/16	4 7/16	19/32	0.104	11/32	0.011	0.104	1,100	0.35
207	72MS2	3 15/16	13/32	3/8	3 3/16	4 13/16	19/32	0.134	3/8	0	0.044	1,700	0.50
	0.149							0.014			1,900		
	0.104							0.104			1,400		
4-Bolt													
208	80MSC1	4 11/16	17/32	1/2	3 9/16	5 13/16	49/64	0.134	13/32	0.013	0.107	1,700	0.80
209	85MSC1	4 3/4	17/32	1/2	3 13/16	5 7/8	49/64	0.134	7/16	0.013	0.107	1,700	1.00
210	90MSC1	5	17/32	1/2	4	6 1/8	49/64	0.149	7/16	0	0.077	1,900	1.00
211	100MSC1	5 7/16	17/32	1/2	4 7/16	6 9/16	49/64	0.149	15/32	0	0.077	1,900	1.10

Additional Notes

- Please call 1-866-REXNORD for availability
- Assembly requires two housing halves
- For bearing insert information, see Unmounted Replacement Bearings section on pages 379 - 398.
- Note: Dimensions subject to change. Certified dimensions of ordered material furnished on request.

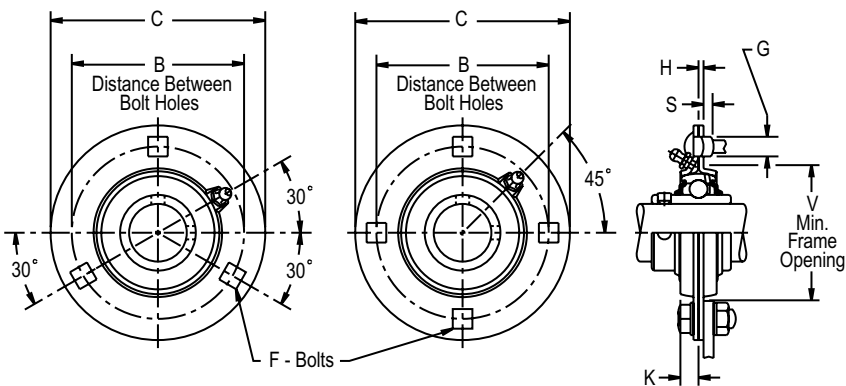
GMSA, GMSB



Photo Shows a Formed Steel 3-Bolt or 4-Bolt Round Flanged Housing Half

Product Features

- 2-piece formed steel housing
- For collar mounted, round, square or hex bore bearings
- Alignable & relubricatable
- 3 or 4-bolt carriage mounting
- Bearing not included
- See Features and Benefits for additional info on pages 286 - 287.



Bearing Dimensions

Size Code	Part Number	B Distance Between Bolt Holes	F - Bolts		V Frame Opening	C	G	H	K	S Carriage Bolts		Radial Load Rating	Approx. Weight
			Hole Size	Bolt Size						Short Shank	Long Shank		
3-Bolt													
205	G52MSA	3	11/32	5/16	2 3/8	3 3/4	1/2	0.083	11/32	0.021	0.115	800	0.30
206	G62MSA	3 9/16	13/32	3/8	2 13/16	4 7/16	19/32	0.104	3/8	0.011	0.104	1,100	0.50
	G62MSA3							0		0.044	1,400		
	G62MSB							0.011		0.104	1,100		
	G62MSB3							0		0.044	1,400		
207	G72MSA	3 15/16	13/32	3/8	3 3/16	4 13/16	13/32	0.134	7/16	0	0.044	1,400	0.50
	G72MSB												
4-Bolt													
208	G80MSA	4 11/16	17/32	1/2	3 9/16	5 13/16	49/64	0.149	5/8	0.013	0.107	1,700	0.90
	G80MSB												
209	G85MSA	4 3/4	17/32	1/2	3 13/16	5 7/8	49/64	0.149	5/8	0.013	0.107	1,700	0.90
	G85MSB												
210	G90MSA	5	17/32	1/2	4	6 1/8	49/64	0.164	1/2	0	0.077	1,900	1.00
	G90MSB												
211	G100MSA	5 7/16	17/32	1/2	4 9/16	6 9/16	49/64	0.164	5/8	0	0.077	2,300	1.20
	G100MSB												

Additional Notes

- Please call 1-866-REXNORD for availability
- Assembly requires one GMSA & one GMSB
- G100MSA & G100MSB hole tolerance +/- .015 in (+/- .038 mm)
- GMSA are housing halves with straight lube fittings
- GMSB are housing halves without fittings

For bearing insert information, see Unmounted Replacement Bearings section on pages 379 - 398.

Note: Dimensions subject to change. Certified dimensions of ordered material furnished on request.

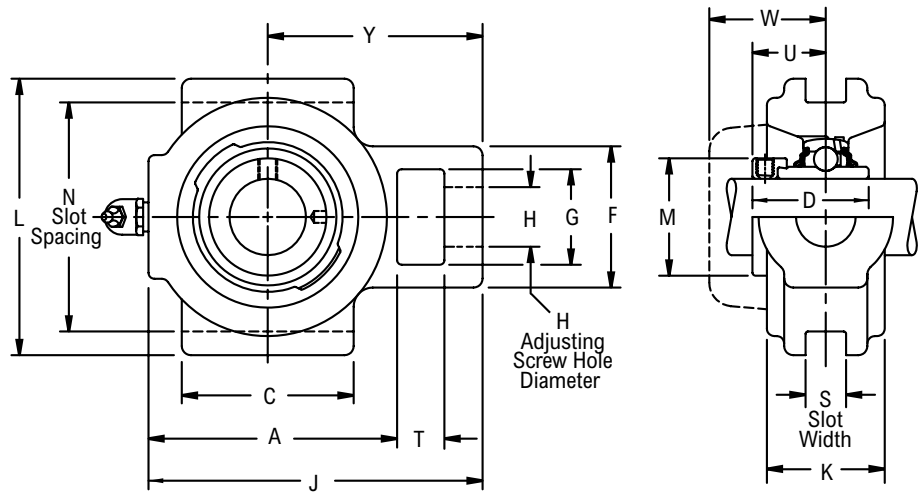
T3Y200



Photo Shows a Ball Bearing Take-up Unit

Product Features

- Corrosion-resistant powder coating
- Cast iron housing
- Standard slot design
- Broad range of sealing options
- Wide inner ring for increased shaft stability
- Eccentric cam locking device
- Alignable & relubricatable
- See Features and Benefits for additional info on pages 286 - 287.



Bearing Dimensions

Size Code	Shaft Diameter	Part Number	H Adjusting Screw Clearance	N Slot Spacing	S Slot Width	A	C	D	F	G	J	K	L	T	U	W	Y	Approx. Weight
203	$\frac{5}{8}$	T3Y210N*■	$\frac{9}{16}$	1.875	0.281	$2\frac{3}{16}$	$1\frac{7}{8}$	$1\frac{15}{32}$	$1\frac{11}{16}$	$1\frac{1}{16}$	3	$1\frac{3}{16}$	$2\frac{1}{4}$	$\frac{1}{2}$	$\frac{59}{64}$	$1\frac{13}{64}$	$1\frac{15}{16}$	1.00
	$\frac{11}{16}$	T3Y211N*■																
	$\frac{1}{2}$	T3Y2B08N*■																
204	$\frac{3}{4}$	T3Y212N*■	$\frac{9}{16}$	2.125	0.281	$2\frac{1}{2}$	$1\frac{7}{8}$	$1\frac{23}{32}$	$1\frac{11}{16}$	$1\frac{1}{16}$	$3\frac{5}{16}$	$1\frac{5}{16}$	$2\frac{5}{8}$	$\frac{1}{2}$	$1\frac{3}{64}$	$1\frac{5}{16}$	$2\frac{3}{32}$	1.50
	$\frac{7}{8}$	T3Y214NΔ*■																
205	$\frac{15}{16}$	T3Y215NΔ*■	$\frac{9}{16}$	2.375	0.281	$2\frac{3}{4}$	2	$1\frac{3}{4}$	$1\frac{11}{16}$	$1\frac{1}{16}$	$3\frac{9}{16}$	1	$2\frac{7}{8}$	$\frac{1}{2}$	$1\frac{1}{16}$	$1\frac{5}{16}$	$2\frac{7}{32}$	2.00
	1	T3Y216NΔ*■																
206	$1\frac{1}{8}$	T3Y218NΔ*■	$\frac{5}{8}$	2.875	0.406	$3\frac{1}{4}$	$2\frac{3}{8}$	$1\frac{29}{32}$	$1\frac{7}{8}$	$1\frac{1}{8}$	$4\frac{3}{16}$	$1\frac{3}{32}$	$3\frac{1}{2}$	$\frac{9}{16}$	$1\frac{3}{16}$	$1\frac{29}{64}$	$2\frac{19}{32}$	3.00
	$1\frac{3}{16}$	T3Y219NΔ*■																
	$1\frac{1}{4}$	T3Y2E20NΔ*■																
207	$1\frac{1}{4}$	T3Y220NΔ*■	$\frac{11}{16}$	3.375	0.406	$3\frac{11}{16}$	$2\frac{5}{8}$	$2\frac{1}{64}$	2	$1\frac{1}{4}$	$4\frac{11}{16}$	$1\frac{3}{16}$	4	$\frac{5}{8}$	$1\frac{9}{32}$	$1\frac{35}{64}$	$2\frac{7}{8}$	3.40
	$1\frac{3}{8}$	T3Y222NΔ*■																
	$1\frac{7}{16}$	T3Y223NΔ*■																
208	$1\frac{1}{2}$	T3Y224NΔ*■	$\frac{11}{16}$	3.500	0.406	$4\frac{1}{16}$	$2\frac{7}{8}$	$2\frac{7}{32}$	2	$1\frac{1}{4}$	$5\frac{1}{8}$	$1\frac{11}{32}$	$4\frac{1}{8}$	$\frac{5}{8}$	$1\frac{3}{8}$	$1\frac{41}{64}$	$3\frac{1}{8}$	4.50
	$1\frac{5}{8}$	T3Y226NΔ*■																
209	$1\frac{11}{16}$	T3Y227NΔ*■	$\frac{7}{8}$	3.750	0.406	$4\frac{5}{16}$	$3\frac{1}{8}$	$2\frac{7}{32}$	$2\frac{1}{4}$	$1\frac{7}{16}$	$5\frac{3}{8}$	$1\frac{3}{8}$	$4\frac{1}{2}$	$\frac{5}{8}$	$1\frac{3}{8}$	$1\frac{21}{32}$	$3\frac{1}{4}$	5.30
	$1\frac{3}{4}$	T3Y228NΔ*■																
210	$1\frac{15}{16}$	T3Y231NΔ*■	$\frac{7}{8}$	4.000	0.406	$4\frac{9}{16}$	$3\frac{1}{4}$	$2\frac{15}{32}$	$2\frac{1}{4}$	$1\frac{7}{16}$	$5\frac{5}{8}$	$1\frac{13}{32}$	$4\frac{3}{4}$	$\frac{5}{8}$	$1\frac{1}{2}$	$1\frac{53}{64}$	$3\frac{3}{8}$	6.00
211	2	T3Y232NΔ*■	$1\frac{1}{8}$	4.500	0.531	5	$3\frac{3}{4}$	$2\frac{13}{16}$	$2\frac{7}{8}$	$1\frac{15}{16}$	$6\frac{1}{4}$	$1\frac{9}{16}$	$5\frac{1}{4}$	$\frac{3}{4}$	$1\frac{23}{32}$	$2\frac{1}{64}$	$3\frac{25}{32}$	7.60
	$2\frac{3}{16}$	T3Y235NΔ*■																

Additional Notes

- Please call 1-866-REXNORD for availability
- Lubrication fitting tap size: for size code 203, 1/4 in-28 UNF: for all other size codes, 1/8 in PT
- * N lip seals standard
- Available with H labyrinth seals
- Δ Available with E3 triple lip seals

For the Selection Guide, Load Ratings and Speed Limits, see the Link-Belt 200 Series Ball Bearing Engineering section on pages 290 - 298.
 Note: Dimensions subject to change. Certified dimensions of ordered material furnished on request.

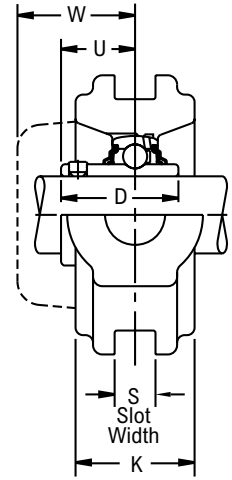
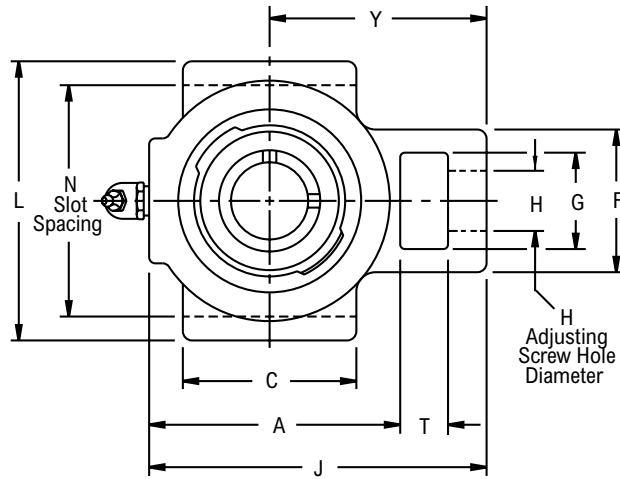
T3U200



Photo Shows a Ball Bearing Take-up Unit

Product Features

- Corrosion-resistant powder coating
 - Cast iron housing
 - Standard slot design
 - Broad range of sealing options
 - Wide inner ring for increased shaft stability
 - Spring locking setscrew mount
 - Alignable & relubricatable
- See Features and Benefits for additional info on pages 286 - 287.



Bearing Dimensions

Size Code	Shaft Diameter	Part Number	H Adjusting Screw Clearance	N Slot Spacing	S Slot Width	A	C	D	F	G	J	K	L	T	U	W	Y	Approx. Weight
203	⁵ / ₈	T3U210N*■	⁹ / ₁₆	1 ⁷ / ₈	0.281	2 ³ / ₁₆	1 ⁷ / ₈	1 ³ / ₃₂	1 ¹¹ / ₁₆	1 ¹ / ₁₆	3	¹³ / ₁₆	2 ¹ / ₄	¹ / ₂	⁴¹ / ₆₄	1 ¹³ / ₆₄	1 ¹⁵ / ₁₆	1.00
	¹¹ / ₁₆	T3U211N*■																
	¹ / ₂	T3U2B08N*■																
204	17.00	T3U2M17N*■	14.30	47.620	7.140	55.60	47.60	27.78	42.90	27.00	76.20	20.60	57.20	12.70	16.30	30.60	49.20	0.45
	³ / ₄	T3U212N*■	⁹ / ₁₆	2 ¹ / ₈	0.281	2 ¹ / ₂	1 ⁷ / ₈	1 ⁹ / ₃₂	1 ¹¹ / ₁₆	1 ¹ / ₁₆	3 ⁵ / ₁₆	¹⁵ / ₁₆	2 ⁵ / ₈	¹ / ₂	³ / ₄	1 ⁵ / ₁₆	2 ³ / ₃₂	1.50
	20.00	T3U2M20N*■	14.30	53.980	7.140	63.50	47.60	32.54	42.90	27.00	84.10	23.80	66.70	12.70	19.00	33.30	53.20	0.68
205	⁷ / ₈	T3U214N*Δ	⁹ / ₁₆	2 ³ / ₈	0.281	2 ³ / ₄	2	1 ²³ / ₆₄	1 ¹¹ / ₁₆	1 ¹ / ₁₆	3 ⁹ / ₁₆	1	2 ⁷ / ₈	¹ / ₂	⁵¹ / ₆₄	1 ⁵ / ₁₆	2 ⁷ / ₃₂	2.00
	¹⁵ / ₁₆	T3U215N*Δ																
	1	T3U216N*Δ																
206	25.00	T3U2M25N*Δ	14.30	60.320	7.140	69.80	50.80	34.53	42.90	27.00	90.50	25.40	73.00	12.70	20.20	33.30	56.40	0.90
	1 ¹ / ₈	T3U218N*Δ	⁵ / ₈	2 ⁷ / ₈	0.406	3 ¹ / ₄	2 ³ / ₈	1 ⁹ / ₁₆	1 ⁷ / ₈	1 ¹ / ₈	4 ³ / ₁₆	1 ³ / ₃₂	3 ¹ / ₂	⁹ / ₁₆	⁶¹ / ₆₄	1 ²⁹ / ₆₄	2 ¹⁹ / ₃₂	3.00
	1 ³ / ₁₆	T3U219N*Δ																
1 ¹ / ₄	T3U2E20N*Δ																	
207	30.00	T3U2M30N*Δ	15.90	73.020	10.310	82.60	60.30	39.69	47.60	28.60	106.40	27.80	88.90	14.30	24.20	36.90	65.90	1.35
	1 ¹ / ₄	T3U220N*Δ	¹¹ / ₁₆	3 ³ / ₈	0.406	3 ¹¹ / ₁₆	2 ⁵ / ₈	1 ⁴⁹ / ₆₄	2	1 ¹ / ₄	4 ¹¹ / ₁₆	1 ³ / ₁₆	4	⁵ / ₈	1 ⁷ / ₆₄	1 ³⁵ / ₆₄	2 ⁷ / ₈	3.40
	1 ³ / ₈	T3U222N*Δ																
1 ⁷ / ₁₆	T3U223N*Δ																	
208	35.00	T3U2M35N*Δ	17.50	85.720	10.310	93.70	66.70	44.85	50.80	31.80	119.10	30.20	101.60	15.90	28.20	39.30	73.00	1.50
	1 ¹ / ₂	T3U224N*Δ	¹¹ / ₁₆	3 ¹ / ₂	0.406	4 ¹ / ₁₆	2 ⁷ / ₈	1 ²⁹ / ₃₂	2	1 ¹ / ₄	5 ¹ / ₈	1 ¹¹ / ₃₂	4 ¹ / ₈	⁵ / ₈	1 ¹¹ / ₆₄	1 ⁴¹ / ₆₄	3 ¹ / ₈	4.50
	40.00	T3U2M40N*Δ	17.50	88.900	10.310	103.20	73.00	48.42	50.80	31.80	130.20	34.10	104.80	15.90	29.80	41.70	79.40	2.00
209	1 ⁵ / ₈	T3U226N*Δ	⁷ / ₈	3 ³ / ₄	0.406	4 ⁵ / ₁₆	3 ¹ / ₈	2 ¹ / ₃₂	2 ¹ / ₄	1 ⁷ / ₁₆	5 ³ / ₈	1 ³ / ₈	4 ¹ / ₂	⁵ / ₈	1 ¹⁵ / ₆₄	1 ²¹ / ₃₂	3 ¹ / ₄	5.30
	1 ¹¹ / ₁₆	T3U227N*Δ																
	1 ³ / ₄	T3U228N*Δ																
210	45.00	T3U2M45N*Δ	22.20	95.250	10.310	109.50	79.40	51.59	57.20	36.50	136.50	34.90	114.30	15.90	31.40	42.10	82.60	2.40
	1 ¹⁵ / ₁₆	T3U231N*Δ	⁷ / ₈	4	0.406	4 ⁹ / ₁₆	3 ¹ / ₄	2 ³ / ₃₂	2 ¹ / ₄	1 ⁷ / ₁₆	5 ⁵ / ₈	1 ¹³ / ₃₂	4 ³ / ₄	⁵ / ₈	1 ¹⁷ / ₆₄	1 ⁵³ / ₆₄	3 ³ / ₈	6.00
	2	T3U2E32N*Δ	22.20	101.600	10.310	115.90	82.60	53.18	57.20	36.50	142.90	35.70	120.60	15.90	32.10	46.40	85.70	2.70
211	50.00	T3U2M50N*Δ	22.20	101.600	10.310	115.90	82.60	53.18	57.20	36.50	142.90	35.70	120.60	15.90	32.10	46.40	85.70	2.70
	2	T3U232N*Δ	1 ¹ / ₈	4 ¹ / ₂	0.531	5	3 ³ / ₄	2 ¹ / ₄	2 ⁷ / ₈	1 ¹⁵ / ₁₆	6 ¹ / ₄	1 ⁹ / ₁₆	5 ¹ / ₄	³ / ₄	1 ¹³ / ₃₂	2 ¹ / ₆₄	3 ²⁵ / ₃₂	7.60
	2 ³ / ₁₆	T3U235N*Δ																
55.00	T3U2M55N*Δ	28.60																

Additional Notes

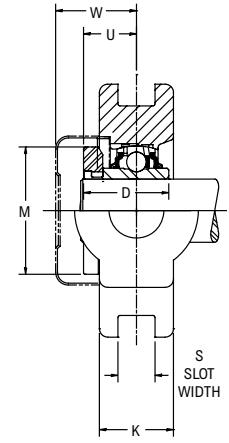
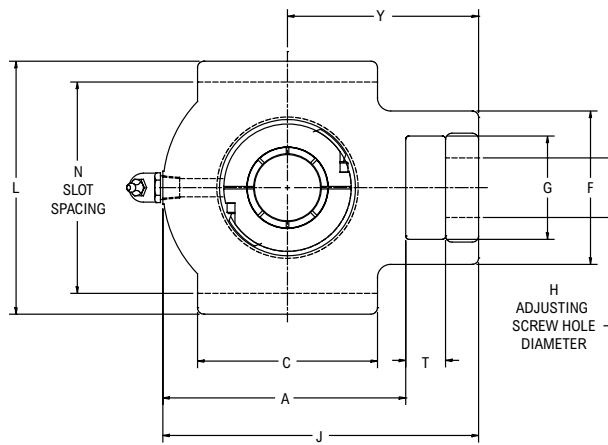
- Please call 1-866-REXNORD for availability
- Lubrication fitting tap size: for size code 203, 1/4 in-28 UNF; for all other size codes, 1/8 in PT
- * N lip seals standard
- Available with H labyrinth seals
- Δ Available with E3 triple lip seals

For the Selection Guide, Load Ratings and Speed Limits, see the Link-Belt 200 Series Ball Bearing Engineering section on pages 290 - 298.

Note: Dimensions subject to change. Certified dimensions of ordered material furnished on request.

TH3CL200

Interchange: WSTUDL, GRT200, ST-T



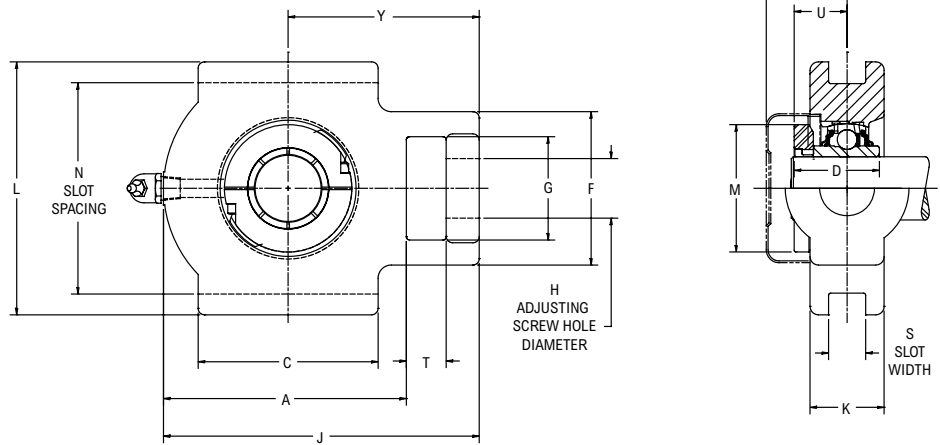
Product Features

- Corrosion-resistant powder coating
- Cast iron housing
- Wide slot design
- Broad range of sealing options
- Wide inner ring for increased shaft stability
- Alignable & relubricatable
- See Features and Benefits for additional info on pages 286 - 287.

Bearing Dimensions

Size Code	Shaft Diameter	Part Number	H Adjusting Screw Clearance	N Slot Spacing	S Slot Width	A	C	D	F	G	J	K	L	M	T	U	Y	W	Approx. Weight
204	1/2	TH3CL2B08N*Δ	3/4	3	0.531	2 ²⁷ / ₃₂	2 1/4	1 11/32	1 7/8	1 1/4	3 ³¹ / ₃₂	1 1/16	3 5/8	2 1/16	5/8	0.84	2 ²¹ / ₃₂	1 ²¹ / ₆₄	2.40
	3/4	TH3CL212N*Δ																	
	20.00	TH3CL2M20N*Δ																	
205	7/8	TH3CL214N*Δ	3/4	3	0.531	2 ²⁹ / ₃₂	2 1/4	1 3/8	1 ²⁷ / ₃₂	1 1/4	4 ¹ / ₃₂	1 3/32	3 5/8	2 ¹³ / ₆₄	5/8	0.81	2 ²¹ / ₃₂	1 ⁹ / ₁₆	2.70
	15/16	TH3CL215N*Δ																	
	1	TH3CL216N*Δ																	
	25.00	TH3CL2M25N*Δ																	
206	1	TH3CL2B16N*Δ	7/8	3 1/2	0.531	3 ¹¹ / ₃₂	2 1/2	1 9/16	2 3/16	1 7/16	4 ¹⁵ / ₃₂	1 3/32	4 1/8	2 ¹⁹ / ₃₂	5/8	0.95	2 ²⁷ / ₃₂	1 ¹⁵ / ₃₂	3.20
	1 1/8	TH3CL218N*Δ																	
	1 3/16	TH3CL219N*Δ																	
	1 1/4	TH3CL2E20N*Δ																	
30.00	TH3CL2M30N*Δ	22.23	88.900	13.490	84.90	63.50	39.62	55.60	36.50	113.50	27.80	104.80	65.88	15.90	24.13	72.20	37.34	1.45	
207	1 3/16	TH3CL2B19N*Δ	7/8	3 1/2	0.531	3 ¹¹ / ₁₆	2 3/4	1 3/4	2 5/16	1 7/16	4 ¹³ / ₁₆	1 3/16	4 1/8	3 ³ / ₆₄	5/8	1.09	2 ³¹ / ₃₂	1 ³⁷ / ₆₄	4.00
	1 1/4	TH3CL220N*Δ																	
	1 3/8	TH3CL222N*Δ																	
	1 7/16	TH3CL223N*Δ																	
35.00	TH3CL2M35N*Δ	22.23	88.900	13.490	93.70	69.90	44.45	58.70	36.50	122.20	30.20	104.80	77.39	15.90	27.69	75.40	40.13	1.80	
208	1 7/16	TH3CL2B23N*Δ	1 1/8	3.969	0.688	4 ³ / ₁₆	3 1/4	1 ¹⁵ / ₁₆	2 ²⁷ / ₃₂	1 ¹⁵ / ₁₆	5 9/16	1 5/16	4 3/4	3 ³ / ₁₆	3/4	1.22	3 ¹⁵ / ₃₂	1 ⁴³ / ₆₄	5.30
	1 1/2	TH3CL224N*Δ																	
	1 5/8	TH3CL2E26N*Δ																	
40.00	TH3CL2M40N*Δ	28.60	100.810	17.480	106.40	82.60	49.28	72.20	49.20	141.30	33.30	120.70	80.96	19.00	30.73	88.10	42.42	2.40	
209	1 1/2	TH3CL2B24N*Δ	1 1/8	3.969	0.688	4 ³ / ₁₆	3 1/4	1 ⁶¹ / ₆₄	2 ⁷ / ₈	1 ¹⁵ / ₁₆	5 9/16	1 3/8	4 3/4	3 ³ / ₈	3/4	1.20	3 ¹⁵ / ₃₂	1 ¹¹ / ₁₆	5.30
	1 5/8	TH3CL226N*Δ																	
	1 11/16	TH3CL227N*Δ																	
	1 3/4	TH3CL228N*Δ																	
45.00	TH3CL2M45N*Δ	28.60	100.810	17.480	106.40	82.60	49.53	73.00	49.20	141.30	34.90	120.70	85.73	19.00	30.48	88.10	42.67	2.40	
210	1 11/16	TH3CL2B27N*Δ	1 1/8	3.969	0.688	4 ⁹ / ₁₆	3 3/8	2 ⁵ / ₆₄	2 ⁷ / ₈	1 ¹⁵ / ₁₆	5 ¹⁵ / ₁₆	1 ⁴³ / ₆₄	4 3/4	3 ³ / ₄	3/4	1.33	3 ¹⁹ / ₃₂	1 ⁵¹ / ₆₄	6.60
	1 3/4	TH3CL2B28N*Δ																	
	1 7/8	TH3CL230N*Δ																	
	1 15/16	TH3CL231N*Δ																	
	2	TH3CL2E32N*Δ																	
50.00	TH3CL2M50N*Δ	28.60	100.810	17.480	115.90	85.70	52.58	73.00	49.20	150.80	42.50	120.70	95.25	19.00	33.53	91.30	45.72	3.00	

Continued...



Continued...

Bearing Dimensions

Size Code	Shaft Diameter	Part Number	H Adjusting Screw Clearance	N Slot Spacing	S Slot Width	A	C	D	F	G	J	K	L	M	T	U	Y	W	Approx. Weight
211	1 15/16	TH3CL2B31N*Δ	1 3/8	5.094	1.062	5 7/16	4	2 15/64	3 19/32	2 1/2	7 7/16	1 3/4	5 7/8	4 5/64	1 1/4	1.41	4 23/32	1 15/16	13.50
	2	TH3CL232N*Δ																	
	2 3/16	TH3CL235N*Δ																	
	2 1/4	TH3CL2E36N*Δ	34.90	129.390	26.970	138.10	101.60	56.90	91.30	63.50	188.90	44.50	149.20	103.58	31.80	35.56	119.90	49.28	6.00
212	2 3/16	TH3CL2B35N*Δ	1 3/8	5.094	1.062	5 7/16	4	3 1/16	3 19/32	2 1/2	7 7/16	2 1/16	5 7/8	4 9/32	1 1/4	2.06	4 23/32	2 13/32	12.90
	2 1/4	TH3CL236N*Δ																	
	2 3/8	TH3CL238N*Δ																	
	2 7/16	TH3CL239N*Δ	34.90	129.390	26.970	138.10	101.60	77.72	91.30	63.50	188.90	52.40	149.20	108.74	31.80	52.32	119.90	60.96	5.80

Additional Notes

Please call 1-866-REXNORD for availability
 Lubrication fitting tap size, 1/8 in PT
 * N lip seals standard
 ■ Available with H labyrinth seals
 Δ Available with E3 triple lip seals

For the Selection Guide, Load Ratings and Speed Limits, see the Link-Belt 200 Series Ball Bearing Engineering section on pages 290 - 298.
 Note: Dimensions subject to change. Certified dimensions of ordered material furnished on request.

TH3Y200

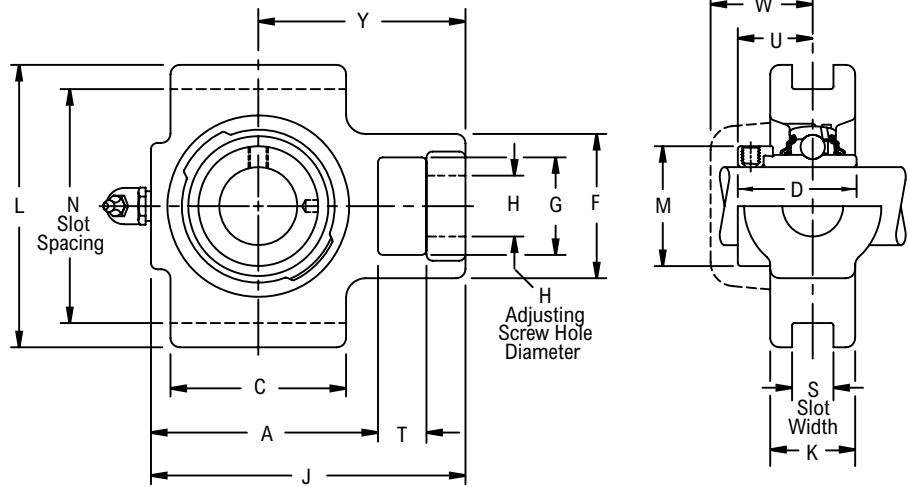
Interchange: WSTUSXR, TU-WF, RTU



Photo Shows a Ball Bearing Take-up Unit

Product Features

- Corrosion-resistant powder coating
- Cast iron housing
- Wide slot design
- Broad range of sealing options
- Wide inner ring for increased shaft stability
- Eccentric cam locking device
- Alignable & relubricatable
- See Features and Benefits for additional info on pages 286 - 287.



Bearing Dimensions

Size Code	Shaft Diameter	Part Number	H Adjusting Screw Clearance	N Slot Spacing	S Slot Width	A	C	D	F	G	J	K	L	M	T	U	W	Y	Approx. Weight
204	3/4	TH3Y212N* \blacksquare	3/4	3	0.531	2 27/32	2 1/4	1 23/32	1 7/8	1 1/4	3 31/32	1 1/16	3 5/8	1 5/16	5/8	1 3/64	1 5/16	2 21/32	2.40
	7/8	TH3Y214N* Δ																	
205	15/16	TH3Y215N* \blacksquare	3/4	3	0.531	2 29/32	2 1/4	1 3/4	1 27/32	1 1/4	4 1/32	1 3/32	3 5/8	1 1/2	5/8	1 1/16	1 5/16	2 21/32	2.70
	1	TH3Y216N* Δ																	
206	1 1/8	TH3Y218N* \blacksquare	7/8	3 1/2	0.531	3 11/32	2 1/2	1 29/32	2 3/16	1 7/16	4 15/32	1 3/32	4 1/8	1 3/4	5/8	1 3/16	1 29/64	2 27/32	3.20
	1 3/16	TH3Y219N* Δ																	
	1 1/4	TH3Y220N* Δ																	
207	1 1/4	TH3Y220N* \blacksquare	7/8	3 1/2	0.531	3 11/16	2 3/4	2 1/64	2 5/16	1 7/16	4 13/16	1 3/16	4 1/8	2 3/16	5/8	1 9/32	1 5/8	2 31/32	4.00
	1 3/8	TH3Y222N* Δ																	
	1 7/16	TH3Y223N* Δ																	
208	1 1/2	TH3Y224N* \blacksquare	1 1/8	3.969	0.688	4 3/16	3 1/4	2 7/32	2 27/32	1 15/16	5 9/16	1 5/16	4 3/4	2 3/8	3/4	1 3/8	1 41/64	3 15/32	5.30
	1 5/8	TH3Y226N* Δ																	
209	1 11/16	TH3Y227N* Δ	1 1/8	3.969	0.688	4 3/16	3 1/4	2 7/32	2 7/8	1 15/16	5 9/16	1 3/8	4 3/4	2 1/2	3/4	1 3/8	1 3/4	3 15/32	5.30
	1 3/4	TH3Y228N* Δ																	
210	1 15/16	TH3Y231N* \blacksquare	1 1/8	3.969	0.688	4 9/16	3 3/8	2 15/32	2 7/8	1 15/16	5 15/16	1 43/64	4 3/4	2 3/4	3/4	1 1/2	1 25/32	3 19/32	6.60
	2	TH3Y232N* Δ																	
211	2	TH3Y232N* \blacksquare	1 3/8	5.094	1.062	5 7/16	4	2 13/16	3 19/32	2 1/2	7 7/16	1 3/4	5 7/8	3	1 1/4	1 23/32	2 1/64	4 23/32	13.50
	2 3/16	TH3Y235N* Δ																	
212	2 1/4	TH3Y236N* Δ																	
	2 3/8	TH3Y238N* \blacksquare	1 3/8	5.094	1.062	5 7/16	4	3 1/16	3 19/32	2 1/2	7 7/16	2 1/16	5 7/8	3 5/16	1 1/4	1 27/32	2 7/64	4 23/32	12.90
	2 7/16	TH3Y239N* Δ																	

Additional Notes

- Please call 1-866-REXNORD for availability
- Lubrication fitting tap size, 1/8 in PT
- * N lip seals standard
- \blacksquare Available with H labyrinth seals
- Δ Available with E3 triple lip seals

For the Selection Guide, Load Ratings and Speed Limits, see the Link-Belt 200 Series Ball Bearing Engineering section on pages 290 - 298.
 Note: Dimensions subject to change. Certified dimensions of ordered material furnished on request.

TH3U200

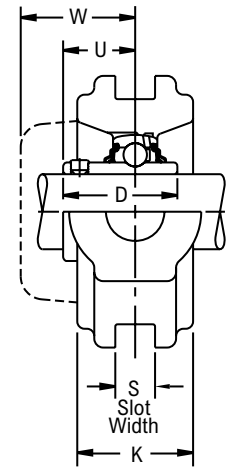
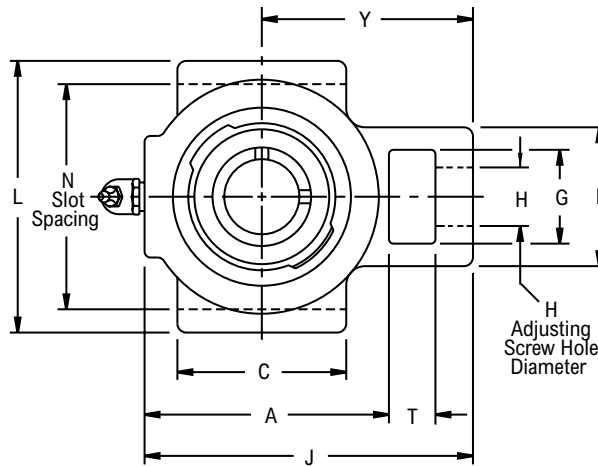
Interchange: WSTUSC, TU-TF, UCT200, ST, YTU



Photo Shows a Ball Bearing Take-up Unit

Product Features

- Corrosion-resistant powder coating
- Cast iron housing
- Wide slot design
- Broad range of sealing options
- Wide inner ring for increased shaft stability
- Spring locking setscrew mount
- Alignable & relubricatable
- See Features and Benefits for additional info on pages 286 - 287.



Bearing Dimensions

Size Code	Shaft Diameter	Part Number	H Adjusting Screw Clearance	N Slot Spacing	S Slot Width	A	C	D	F	G	J	K	L	T	U	W	Y	Approx. Weight
204	3/4	TH3U212N* ■	3/4	3	0.531	2 27/32	2 1/4	1 9/32	1 7/8	1 1/4	3 31/32	1 1/16	3 5/8	5/8	3/4	1 5/16	2 21/32	2.40
	7/8	TH3U214N* Δ																
205	15/16	TH3U215N* ■	3/4	3	0.531	2 29/32	2 1/4	1 23/64	1 27/32	1 1/4	4 1/32	1 3/32	3 5/8	5/8	51/64	1 5/16	2 21/32	2.70
	1	TH3U216N* Δ																
206	1 1/8	TH3U218N* Δ	7/8	3 1/2	0.531	3 11/32	2 1/2	1 9/16	2 3/16	1 7/16	4 15/32	1 3/32	4 1/8	5/8	61/64	1 29/64	2 27/32	3.20
	1 3/16	TH3U219N* ■																
	1 1/4	TH3U220N* Δ																
207	1 1/4	TH3U220N* Δ	7/8	3 1/2	0.531	3 11/16	2 3/4	1 49/64	2 5/16	1 7/16	4 13/16	1 3/16	4 1/8	5/8	1 7/64	1 35/64	2 31/32	4.00
	1 3/8	TH3U222N* ■														1 5/8		
	1 7/16	TH3U223N* Δ														1 35/64		
208	1 1/2	TH3U224N* Δ	1 1/8	3.969	0.688	4 3/16	3 1/4	1 29/32	2 27/32	1 15/16	5 9/16	1 5/16	4 3/4	3/4	1 11/64	1 41/64	3 15/32	5.30
	1 5/8	TH3U226N* ■																
209	1 11/16	TH3U227N* Δ	1 1/8	3.969	0.688	4 3/16	3 1/4	2 1/32	2 7/8	1 15/16	5 9/16	1 3/8	4 3/4	3/4	1 15/64	1 21/32	3 15/32	5.30
	1 3/4	TH3U228N* Δ																
210	1 15/16	TH3U231N* ■	1 1/8	3.969	0.688	4 9/16	3 3/8	2 3/32	2 7/8	1 15/16	5 15/16	1 43/64	4 3/4	3/4	1 17/64	1 25/32	3 19/32	6.60
	2	TH3U232N* Δ																
211	2	TH3U232N* Δ	1 3/8	5.094	1.062	5 7/16	4	2 1/4	3 19/32	2 1/2	7 7/16	1 3/4	5 7/8	1 1/4	1 13/32	2 1/64	4 23/32	13.50
	2 3/16	TH3U235N* ■																
212	2 1/4	TH3U236N* Δ	1 3/8	5.094	1.062	5 7/16	4	2 1/2	3 19/32	2 1/2	7 7/16	2 1/16	5 7/8	1 1/4	1 9/16	2 7/64	4 23/32	12.90
	2 3/8	TH3U238N* Δ																
	2 7/16	TH3U239N* Δ																

Additional Notes

- Please call 1-866-REXNORD for availability
- Lubrication fitting tap size, 1/8 in PT
- * N lip seals standard
- Available with H labyrinth seals
- Δ Available with E3 triple lip seals

For the Selection Guide, Load Ratings and Speed Limits, see the Link-Belt 200 Series Ball Bearing Engineering section on pages 290 - 298.

Note: Dimensions subject to change. Certified dimensions of ordered material furnished on request.

TH3S200

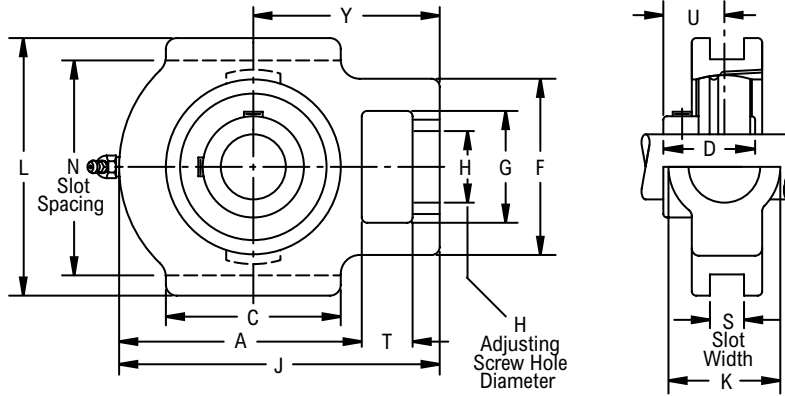
Interchange: WSTUVSC, VTWS100



Photo Shows a Ball Bearing Take-up Unit

Product Features

- Corrosion-resistant powder coating
- Cast iron housing
- Wide slot design
- Broad range of sealing options
- Spring locking setscrew mount
- Alignable & relubricatable
- See Features and Benefits for additional info on pages 286 - 287.



Bearing Dimensions

Size Code	Shaft Diameter	Part Number	H Adjusting Screw Hole Diameter	N Slot Spacing	S Slot Width	A	C	D	F	G	J	K	L	T	U	Y	Approx. Weight
204	³ / ₄	TH3S212E♦♦ □Δ	³ / ₄	3.000	0.531	2 ⁷ / ₈	2	1 ¹ / ₈	2	1 ¹ / ₄	3 ⁷ / ₈	1 ³ / ₈	3 ¹ / ₂	⁵ / ₈	³ / ₄	2 ⁷ / ₁₆	1.86
	20.00	TH3S2M20E♦♦ □Δ	19.00	76.200	13.490	73.02	50.80	28.58	50.80	31.80	98.40	34.90	88.90	15.90	19.00	61.90	0.80
205	⁷ / ₈	TH3S214E♦♦ □Δ	³ / ₄	3.000	0.531	2 ⁷ / ₈	2	1 ¹¹ / ₆₄	2	1 ¹ / ₄	3 ⁷ / ₈	1 ³ / ₈	3 ¹ / ₂	⁵ / ₈	⁵ / ₆₄	2 ⁷ / ₁₆	1.85
	¹⁵ / ₁₆	TH3S215E♦♦ □Δ															1.82
	1	TH3S216E♦♦ □Δ															1.79
	25.00	TH3S2M25E♦♦ □Δ															19.00
206	1 ¹ / ₈	TH3S218E♦♦ □Δ	⁷ / ₈	3.500	0.531	3 ³ / ₈	2 ¹ / ₄	1 ¹¹ / ₃₂	2 ³ / ₁₆	1 ⁷ / ₁₆	4 ¹ / ₂	1 ⁹ / ₁₆	4 ¹ / ₈	¹¹ / ₁₆	⁶¹ / ₆₄	2 ³ / ₄	2.75
	1 ³ / ₁₆	TH3S219E♦♦ □Δ															2.72
	1 ¹ / ₄	TH3S220E♦♦ □Δ															2.69
	30.00	TH3S2M30E♦♦ □Δ															22.20
207	1 ¹ / ₄	TH3S220E♦♦ □Δ	⁷ / ₈	3.500	0.531	4	2 ¹ / ₂	1 ⁹ / ₁₆	2 ³ / ₈	1 ⁷ / ₁₆	5	1 ⁹ / ₁₆	4 ¹ / ₈	¹¹ / ₁₆	1 ⁷ / ₆₄	3 ¹ / ₁₆	3.19
	1 ³ / ₈	TH3S222E♦♦ □Δ															3.09
	1 ⁷ / ₁₆	TH3S223E♦♦ □Δ															3.03
	35.00	TH3S2M35E♦♦ □Δ															22.20
208	1 ¹ / ₂	TH3S224E♦♦ □Δ	1 ¹ / ₈	3.969	0.688	4 ³ / ₁₆	3 ¹ / ₄	1 ²¹ / ₃₂	3 ¹ / ₄	1 ¹⁵ / ₁₆	5 ⁵ / ₈	2 ¹ / ₁₆	4 ³ / ₄	⁷ / ₈	1 ¹¹ / ₆₄	3 ¹ / ₂	5.24
	1 ⁵ / ₈	TH3S226E♦♦ □Δ															5.10
	40.00	TH3S2M40E♦♦ □Δ															28.60
209	1 ³ / ₈	TH3S226E♦♦ □Δ	1 ¹ / ₈	3.969	0.688	4 ³ / ₁₆	3 ¹ / ₄	1 ⁴⁹ / ₆₄	3 ¹ / ₄	1 ¹⁵ / ₁₆	5 ⁵ / ₈	2 ¹ / ₁₆	4 ³ / ₄	⁷ / ₈	1 ¹⁵ / ₆₄	3 ⁷ / ₁₆	4.84
	1 ¹¹ / ₁₆	TH3S227E♦♦ □Δ															4.77
	1 ³ / ₄	TH3S228E♦♦ □Δ															4.70
	1 ⁷ / ₈	TH3S230E♦♦ □Δ															4.96
210	1 ¹⁵ / ₁₆	TH3S231E♦♦ □Δ	1 ¹ / ₈	3.969	0.688	4 ⁷ / ₁₆	3 ¹ / ₄	1 ¹³ / ₁₆	3 ¹ / ₄	1 ¹⁵ / ₁₆	5 ⁷ / ₈	2 ¹ / ₁₆	4 ³ / ₄	⁷ / ₈	1 ¹⁷ / ₆₄	3 ⁹ / ₁₆	4.87
	2	TH3S2E32E♦♦ □Δ															4.78
	2	TH3S232E♦♦ □Δ															8.78
211	2 ³ / ₁₆	TH3S235E♦♦ □Δ	1 ³ / ₈	5.094	1.062	4 ⁷ / ₈	3 ³ / ₄	1 ¹³ / ₁₆	4	2 ¹ / ₂	6 ¹³ / ₁₆	2 ¹ / ₂	5 ⁷ / ₈	1 ³ / ₁₆	1 ⁹ / ₃₂	4 ³ / ₁₆	8.58
	2 ¹ / ₄	TH3S2E36E♦♦ □Δ															8.38
	2 ¹ / ₄	TH3S236E♦♦ □Δ															9.67
212	2 ³ / ₈	TH3S238E♦♦ □Δ	1 ³ / ₈	5.094	1.062	5 ⁵ / ₈	4	1 ⁵⁷ / ₆₄	4	2 ¹ / ₂	7 ⁹ / ₁₆	2 ¹ / ₂	5 ⁷ / ₈	1 ³ / ₁₆	1 ⁵ / ₁₆	4 ¹¹ / ₁₆	9.43
	2 ⁷ / ₁₆	TH3S239E♦♦ □Δ															9.31
215	2 ¹⁵ / ₁₆	TH3S247E♦♦ □Δ	1 ⁵ / ₈	5.906	1.062	6 ²⁷ / ₃₂	4 ³ / ₄	2 ¹⁷ / ₆₄	4 ³ / ₁₆	2 ³ / ₄	8 ¹⁵ / ₁₆	2 ³ / ₄	6 ¹¹ / ₁₆	1 ⁵ / ₁₆	1 ¹⁵ / ₃₂	5 ¹ / ₂	14.24

Additional Notes

- Please call 1-866-REXNORD for availability
- Lubrication fitting tap size, 1/8 in PT
- Lip seals standard
- ♦ Available with E1 viton seals for all size codes
- Available with free running style seals, add suffix ♦ FF, □ HFF or Δ MHFF for all size codes

For the Selection Guide, Load Ratings and Speed Limits, see the Link-Belt 200 Series Ball Bearing Engineering section on pages 290 - 298.
 Note: Dimensions subject to change. Certified dimensions of ordered material furnished on request.

CHBS200

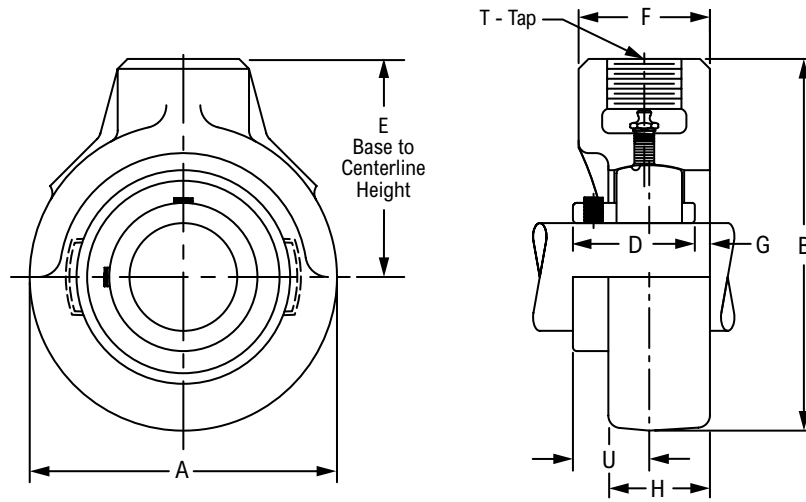
Interchange: SCHB, UCHA200



Photo Shows a Screw Conveyor Hanger Ball Bearing Unit

Product Features

- Corrosion-resistant powder coating
- Cast iron housing
- Broad range of sealing options
- Spring locking setscrew mount
- Alignable & relubricatable
- See Features and Benefits for additional info on pages 286 - 287.



Bearing Dimensions

Size Code	Shaft Diameter	Part Number	E Base to Centerline Height	T		A	B	D	F	G	H	U	Approx. Weight
				Depth	Tap								
206	1 1/8	CHBS218E♦♦ □Δ	2 1/2	5/8	3/4-14	3 3/8	4 3/16	1 11/32	1 21/32	7/16	1 7/32	61/64	2.25
	1 3/16	CHBS219E♦♦ □Δ											2.22
	1 1/4	CHBS2E20E♦♦ □Δ											2.19
	30.00	CHBS2M30E♦♦ □Δ	63.50	15.90	3/4-14	85.70	106.40	34.14	42.10	11.10	31.00	24.20	1.00
207	1 1/4	CHBS220E♦♦ □Δ	2 3/4	5/8	3/4-14	3 7/8	4 11/16	1 9/16	1 21/32	3/8	1 9/32	1 7/64	3.34
	1 3/8	CHBS222E♦♦ □Δ											3.24
	1 7/16	CHBS223E♦♦ □Δ											3.18
	35.00	CHBS2M35E♦♦ □Δ	69.80	15.90	3/4-14	98.40	119.10	39.67	42.10	9.50	32.50	28.20	1.50
208	1 1/2	CHBS224E♦♦ □Δ	2 7/8	5/8	3/4-14	4	4 7/8	1 21/32	1 21/32	11/32	1 11/32	1 11/64	3.39
	1 5/8	CHBS2E26E♦♦ □Δ											3.25
	40.00	CHBS2M40E♦♦ □Δ											73.00
210	1 7/8	CHBS230E♦♦ □Δ	3 1/4	13/16	1-11 1/2	4 5/8	5 9/16	1 13/16	1 7/8	13/32	1 13/32	1 17/64	4.81
	1 15/16	CHBS231E♦♦ □Δ											4.72
	2	CHBS2E32E♦♦ □Δ											4.63
212	2 3/8	CHBS238E♦♦ □Δ	4	1 1/8	1 1/4-11 1/2	5 5/8	6 13/16	1 57/64	2 5/16	37/64	1 5/8	1 5/16	8.08
	2 7/16	CHBS239E♦♦ □Δ											7.96
215	2 3/4	CHBS244E♦♦ □Δ	4 5/8	1 1/4	1 1/2-11 1/2	6 1/2	7 7/8	2 17/64	2 3/4	37/64	1 31/32	1 15/32	12.14
	2 15/16	CHBS247E♦♦ □Δ											11.64

Additional Notes

- Please call 1-866-REXNORD for availability
- Lubrication fitting tap size, 1/8 in PT
- Base to centerline tolerance, +/- .005 in (+/- 0.13 mm)
- Lip seals standard
- ♦ Available with E1 viton seals for all size codes
- ♦ Nickel plated housings available, add suffix K75

Available with free running style seals, add suffix ♦ FF, □ HFF or Δ MHFF for all size codes
 For the Selection Guide, Load Ratings and Speed Limits, see the Link-Belt 200 Series
 Ball Bearing Engineering section on pages 290 - 298.

Note: Dimensions subject to change. Certified dimensions of ordered material furnished on request.

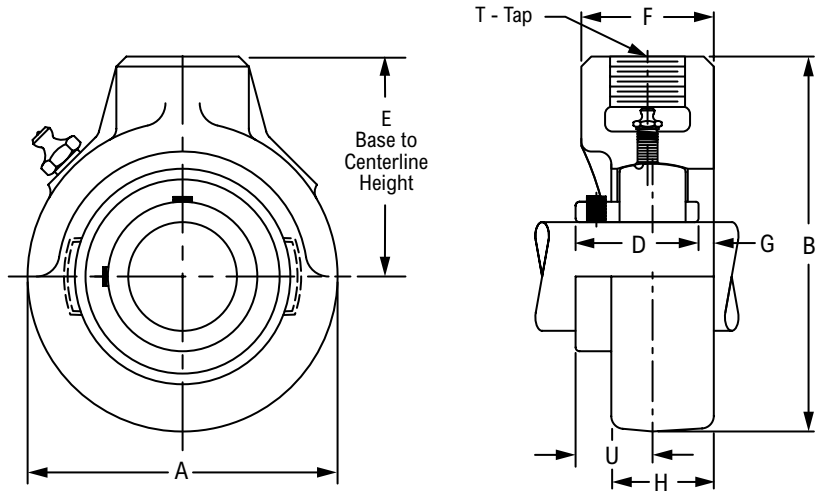
EHBS200
Interchange: *SEHB*



Photo Shows a Screw Conveyor Hanger Ball Bearing Unit

Product Features

- Corrosion-resistant powder coating
- Cast iron housing
- Broad range of sealing options
- Spring locking setscrew mount
- Alignable & relubricatable
- See Features and Benefits for additional info on pages 286 - 287.



Bearing Dimensions

Size Code	Shaft Diameter	Part Number	E Base to Centerline Height	T		A	B	D	F	G	H	U	Approx. Weight
				Depth	Tap								
206	1 1/8	EHBS218E◆●□△	2 1/2	5/8	3/4-14	3 3/8	4 3/16	1 11/32	1 21/32	7/16	1 7/32	61/64	2.25
	1 3/16	EHBS219E◆●□△											2.22
	1 1/4	EHBS2E20E◆●□△											2.19
	30.00	EHBS2M30E◆●□△	63.50	15.90	3/4-14	85.70	106.40	34.14	42.10	11.10	31.00	24.20	1.00
207	1 1/4	EHBS220E◆●□△	2 3/4	5/8	3/4-14	3 7/8	4 11/16	1 9/16	1 21/32	3/8	1 9/32	1 7/64	3.34
	1 3/8	EHBS222E◆●□△											3.24
	1 7/16	EHBS223E◆●□△											3.18
	35.00	EHBS2M35E◆●□△	69.80	15.90	3/4-14	98.40	119.10	39.67	42.10	9.50	32.50	28.20	1.50
208	1 1/2	EHBS224E◆●□△	2 7/8	5/8	3/4-14	4	4 7/8	1 21/32	1 21/32	11/32	1 11/32	1 11/64	3.39
	1 5/8	EHBS2E26E◆●□△											3.25
	40.00	EHBS2M40E◆●□△											73.00
210	1 7/8	EHBS230E◆●□△	3 1/4	13/16	1-11 1/2	4 5/8	5 9/16	1 13/16	1 7/8	13/32	1 13/32	1 17/64	4.81
	1 15/16	EHBS231E◆●□△											4.72
	2	EHBS2E32E◆●□△											4.63
212	2 3/8	EHBS238E◆●□△	4	1 1/8	1 1/4-11 1/2	5 5/8	6 13/16	1 57/64	2 5/16	37/64	1 5/8	1 5/16	8.08
	2 7/16	EHBS239E◆●□△											7.96
215	2 3/4	EHBS244E◆●□△	4 5/8	1 1/4	1 1/2-11 1/2	6 1/2	7 7/8	2 17/64	2 3/4	37/64	1 31/32	1 15/32	12.14
	2 15/16	EHBS247E◆●□△											11.64

Additional Notes

- Please call 1-866-REXNORD for availability
- Lubrication fitting tap size, 1/8 in PT
- Base to centerline tolerance, +/- .005 in (+/- 0.13 mm)
- Lip seals standard
- ◆ Available with E1 viton seals for all size codes
- ◆ Nickel plated housings available, add suffix K75

Available with free running style seals, add suffix ● FF, □ HFF or △ MHFF for all size codes
 For the Selection Guide, Load Ratings and Speed Limits, see the Link-Belt 200 Series Ball Bearing Engineering section on pages 290 - 298.
 Note: Dimensions subject to change. Certified dimensions of ordered material furnished on request.

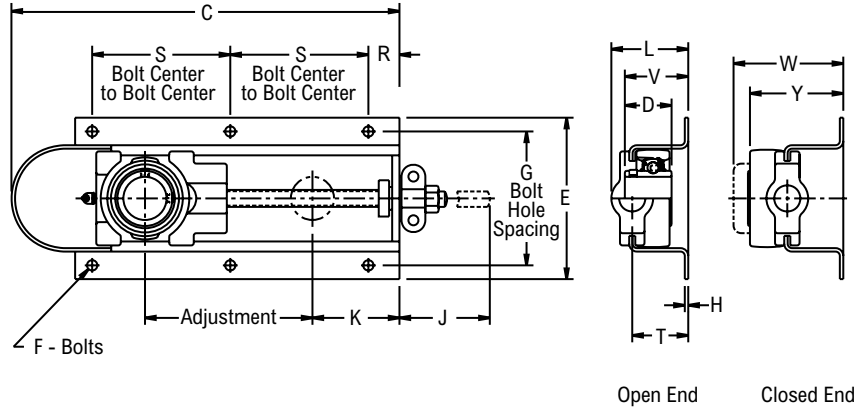
TAS3U200



Photo Shows a Formed Steel Conveyor Take-up Frame with Ball Bearing Take-up Unit

Product Features

- Center pull side mounted steel frame
- Corrosion-resistant powder coating
- Cast iron housing
- Broad range of sealing options
- Wide inner ring for increased shaft stability
- Spring locking setscrew mount
- Alignable & relubricatable
- TAS3U200 take-up unit
- See Features and Benefits for additional info on pages 286 - 287.



Bearing Dimensions

Size Code	Shaft Diameter	Adjust. Length	Part Number	G Bolt Hole Spacing	S Bolt Center to Bolt Center	C	D	E	F Bolts	H	J	K	L	R	T	V	W	Y	Approx. Weight	
205	1 ^{15/16}	6	TAS3U215N6* Δ	4 1/8	4 1/2	13 1/4	1 ^{23/64}	4 7/8	5/16	1/8	7 3/16	3 3/8	2 5/16	1 1/2	1 5/8	1 51/64	3 37/64	2 27/32	7.50	
			TAS3U216N6* Δ																	
	25.00	152	TAS3U2M25N6* Δ	104.80	114.30	336.50	34.53	123.80	8.00	3.20	198.40	85.70	58.70	38.10	41.30	45.60	90.90	72.20	3.40	
206	1 1/8	6	TAS3U218N6* Δ	5 1/4	4 7/8	15	1 9/16	6 1/4	3/8	3/16	8 3/16	3 11/16	2 7/8	1 5/8	2 1/8	2 11/32	4 19/64	3 1/2	11.00	
			TAS3U218N12* Δ																	5 3/8
	1 3/16	6	TAS3U219N6* Δ	5 1/4	4 7/8	15	1 9/16	6 1/4	3/8	3/16	8 3/16	3 11/16	2 7/8	1 5/8	2 1/8	2 11/32	4 19/64	3 1/2	11.00	
			TAS3U219N12* Δ																	5 3/8
	30.00	152	305	TAS3U2M30N6* Δ	133.40	123.80	381.00	39.69	158.80	10.00	4.80	208.00	93.70	73.00	41.30	54.00	59.50	109.10	88.90	4.95
				TAS3U2M30N12* Δ																
207	1 1/4	6	TAS3U220N6* Δ	5 1/4	4 7/8	15	1 49/64	6 1/4	3/8	3/16	8 5/16	3 3/4	2 7/8	1 5/8	2 1/8	2 31/64	4 7/16	3 35/64	13.50	
			TAS3U220N12* Δ																	5 3/8
	1 7/16	6	TAS3U223N6* Δ	5 1/4	4 7/8	15	1 49/64	6 1/4	3/8	3/16	8 5/16	3 3/4	2 7/8	1 5/8	2 1/8	2 31/64	4 7/16	3 35/64	13.00	
			TAS3U223N12* Δ																	5 3/8
	35.00	152	305	TAS3U2M35N6* Δ	133.40	123.80	381.00	44.85	158.80	10.00	4.80	211.10	95.20	73.00	41.30	54.00	63.10	112.70	90.10	6.10
				TAS3U2M35N12* Δ																
208	1 1/2	9	TAS3U224N9* Δ	6 5/8	5	19 3/4	1 29/32	7 7/8	3/8	1/4	11 1/4	4 1/2	3 5/8	1 5/8	2 3/4	3 1/16	5 9/32	4 3/8	24.00	
			TAS3U224N18* Δ																	6
	40.00	229	457	TAS3U2M40N9* Δ	168.30	127.00	501.60	48.42	200.00	10.00	6.40	285.80	114.30	92.10	41.30	69.80	77.80	134.10	111.10	10.80
				TAS3U2M40N18* Δ																
209	1 11/16	9	TAS3U227N9* Δ	6 5/8	5	19 3/4	2 1/32	7 7/8	3/8	1/4	11 3/16	4 5/8	3 5/8	1 5/8	2 3/4	3 1/16	5 7/16	4 1/2	25.50	
			TAS3U227N18* Δ																	6
	1 3/4	9	TAS3U228N9* Δ	6 5/8	5	19 3/4	2 1/32	7 7/8	3/8	1/4	11 3/16	4 5/8	3 5/8	1 5/8	2 3/4	3 1/16	5 7/16	4 1/2	25.00	
			TAS3U228N18* Δ																	6
	45.00	229	457	TAS3U2M45N9* Δ	168.30	127.00	501.60	41.59	200.00	10.00	6.40	284.20	117.50	92.10	41.30	69.80	77.80	138.10	114.30	11.25
				TAS3U2M45N18* Δ																
210	1 15/16	9	TAS3U231N9* Δ	6 5/8	5	19 3/4	2 3/32	7 7/8	3/8	1/4	11 1/4	4 5/8	3 5/8	1 5/8	2 3/4	3 1/16	5 19/32	4 17/32	23.00	
			TAS3U231N18* Δ																	6
	50.00	229	457	TAS3U2M50N9* Δ	168.30	127.00	501.60	53.18	200.00	10.00	6.40	285.80	117.50	92.10	41.30	69.80	77.80	142.10	115.10	10.35
				TAS3U2M50N18* Δ																
211	2	9	TAS3U232N9* Δ	7 1/8	5	21 5/8	2 1/4	8 1/4	1/2	1/4	11 3/16	5 1/2	4 1/4	2 1/2	3 1/4	3 11/16	6 5/16	5 1/16	32.30	
			TAS3U232N18* Δ																	6
	2 3/16	9	TAS3U235N9* Δ	7 1/8	5	21 5/8	2 1/4	8 1/4	1/2	1/4	11 3/16	5 1/2	4 1/4	2 1/2	3 1/4	3 11/16	6 5/16	5 1/16	29.90	
			TAS3U235N18* Δ																	6
	55.00	229	457	TAS3U2M55N9* Δ	181.00	127.00	549.30	57.15	209.60	12.00	6.40	284.20	139.70	108.00	63.50	82.60	93.70	160.30	128.60	13.45
				TAS3U2M55N18* Δ																

Additional Notes

- Please call 1-866-REXNORD for availability
- Lubrication fitting tap size, 1/8 in PT
- Closed end take-ups available, add suffix C
- On closed end take-up, bearing assembly is reversed
- Frames with 6 in (152.40 mm) adjustment have six holes
- Frames with 9 in (228.60 mm) or 12 in (304.80 mm) adjustment have eight holes
- Frames with 18 in (457.20 mm) adjustment have ten holes

* N lip seals standard

- Available with H labyrinth seals
- △ Available with E3 triple lip seals

For the Selection Guide, Load Ratings and Speed Limits, see the Link-Belt 200 Series Ball Bearing Engineering section on pages 290 - 298.

Note: Dimensions subject to change. Certified dimensions of ordered material furnished on request.

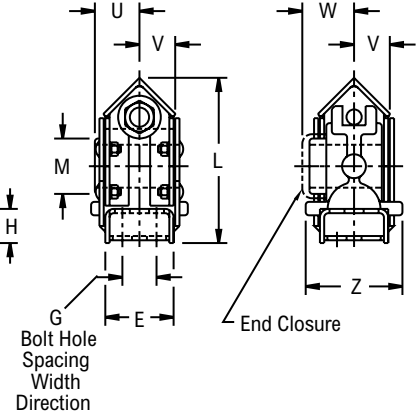
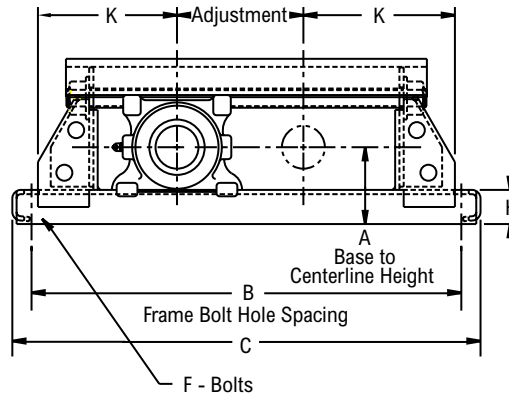
TDS3U200



Photo Shows a Hinged Top, Welded Steel Conveyor Take-up Frame with Ball Bearing Take-up Unit

Product Features

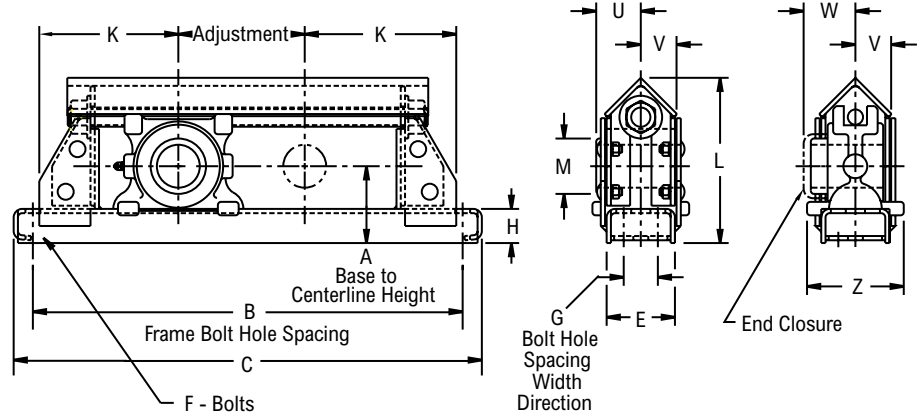
- Protected screw type steel frame
- Corrosion-resistant powder coating
- Cast iron housing
- Broad range of sealing options
- Wide inner ring for increased shaft stability
- Spring locking setscrew mount
- Alignable & relubricatable
- TD3U200 take-up unit
- See Features and Benefits for additional info on pages 286 - 287.



Bearing Dimensions

Size Code	Shaft Diameter	Adjust. Length	Part Number	A Base to Centerline Height	B Frame Bolt Hole Spacing	G Bolt Hole Spacing Width Direction	C	E	F Bolts	H	K	L	M	U	V	W	Z	Approx. Weight
210	1 15/16	12	TDS3U231N12*Δ	3 15/16	26 1/2	-	28 1/2	3	5/8	1 3/4	7 1/4	8 1/4	-	1 17/64	55/64	1 15/16	4 1/8	41.00
		18	TDS3U231N18*Δ		32 1/2		34 1/2											47.00
		24	TDS3U231N24*Δ		38 1/2		40 1/2											52.00
	50.00	305	TDS3U2M50N12*Δ	100.00	673.10	-	723.90	76.20	16.00	44.40	184.20	209.60	-	32.10	21.80	49.20	104.80	18.45
		457	TDS3U2M50N18*Δ		825.50		876.30											21.15
		610	TDS3U2M50N24*Δ		977.90		1,028.70											23.40
211	2 3/16	12	TDS3U235N12*Δ	4 3/16	27 1/2	-	29 1/2	3	5/8	1 3/4	7 3/4	8 11/16	-	1 13/32	55/64	2 3/32	4 1/8	45.00
		18	TDS3U235N18*Δ		33 1/2		35 1/2											51.00
		24	TDS3U235N24*Δ		39 1/2		41 1/2											56.00
	55.00	305	TDS3U2M55N12*Δ	106.40	698.50	-	749.30	76.20	16.00	44.40	196.80	220.70	-	35.70	21.80	53.30	104.80	20.25
		457	TDS3U2M55N18*Δ		850.90		901.70											22.95
		610	TDS3U2M55N24*Δ		1,003.30		1,054.10											25.20
212	2 7/16	12	TDS3U239N12*Δ	4 3/8	28 1/2	-	30 1/2	3	3/4	1 3/4	8 1/4	9 1/8	-	1 9/16	31/32	2 5/32	4 1/8	52.00
		18	TDS3U239N18*Δ		34 1/2		36 1/2											58.00
		24	TDS3U239N24*Δ		40 1/2		42 1/2											63.00
		30	TDS3U239N30*Δ		46 1/2		48 1/2											68.00
	60.00	305	TDS3U2M60N12*Δ	111.10	725.90	-	774.70	76.20	20.00	44.40	209.60	231.80	-	39.70	24.60	54.80	104.80	23.40
		457	TDS3U2M60N18*Δ		876.30		927.10											26.10
215	2 15/16	12	TDSU247N12*Δ	5 1/8	30 1/2	2	32 1/2	4	5/8	2	9 1/4	10 5/8	4 5/8	1 13/16	1 5/32	2 13/64	5 1/8	76.00
		18	TDSU247N18*Δ		36 1/2		38 1/2											85.00
		24	TDSU247N24*Δ		42 1/2		44 1/2											93.00
		30	TDSU247N30*Δ		48 1/2		50 1/2											101.00
	75.00	305	TDSU2M75N12 *Δ	130.20	774.70	50.80	825.50	101.60	16.00	50.80	235.00	269.90	117.50	46.00	29.40	56.00	130.20	34.20
		457	TDSU2M75N18 *Δ		927.10		977.90											38.25
217	3 7/16	12	TDSU255N12*Δ	5 5/8	32	2	34 1/2	4	3/4	2	10	11 13/16	5 3/16	2 1/8	1 7/16	2 1/2	5 5/8	99.00
		18	TDSU255N18*Δ		38		40 1/4											108.00
		24	TDSU255N24*Δ		44		46 1/4											116.00
		30	TDSU255N30*Δ		50		52 1/4											124.00
	85.00	305	TDSU2M85N12 *Δ	142.90	812.80	50.80	870.00	101.60	20.00	50.80	254.00	300.00	131.80	54.00	36.50	63.50	142.90	44.55
		457	TDSU2M85N18 *Δ		965.20		1,022.40											48.60

Continued...



Continued...

Bearing Dimensions

Size Code	Shaft Diameter	Adjust. Length	Part Number	A Base to Centerline Height	B Frame Bolt Hole Spacing	G Bolt Hole Spacing Width Direction	C	E	F Bolts	H	K	L	M	U	V	W	Z	Approx. Weight
217	85.00	610	TDSU2M85N24 *Δ	142.90	1,117.60	50.80	1,174.80	101.60	20.00	50.80	254.00	300.00	131.80	54.00	36.50	63.50	142.90	52.20
		762	TDSU2M85N30 *Δ		1,270.00		1,327.20											55.80
220	3 15/16	12	TDSU263N12*	7	36	2 1/2	38 1/2	5	3/4	2 1/4	12	14 11/16	5 15/16	2 37/64	1 45/64	3 1/64	6 7/8	173.00
		18	TDSU263N18*		42		44 1/2											185.00
		24	TDSU263N24*		48		50 1/2											195.00
		30	TDSU263N30*		54		56 1/2											205.00
		305	TDSU2M100N12*		914.40		977.90											77.85
	100.00	457	TDSU2M100N18*	1,066.80	1,130.30	83.25												
		610	TDSU2M100N24*	1,219.20	1,282.70	87.75												
		762	TDSU2M100N30*	1,371.60	1,435.10	92.25												
				177.80	63.50	127.00	20.00	57.20	304.80	373.10	150.80	65.50	43.20	76.60	174.60			

Additional Notes

Please call 1-866-REXNORD for availability
 Lubrication fitting tap size, 1/8 in PT
 Closed end take-ups available, add suffix C
 Size code 220 has hinged top construction
 Frames with 18 in (457.20 mm) adjustment or more have center supporting pad welded to bottom of frame
 * N lip seals standard

■ Available with H labyrinth seals
 Δ Available with E3 triple lip seals
 For the Selection Guide, Load Ratings and Speed Limits, see the Link-Belt 200 Series Ball Bearing Engineering section on pages 290 - 298.
 Note: Dimensions subject to change. Certified dimensions of ordered material furnished on request.

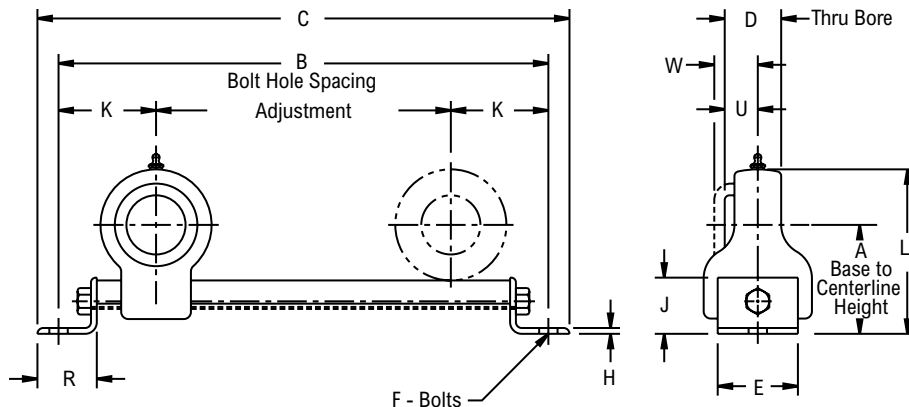
NT3U200



Photo Shows a Welded Channel Conveyor Take-up Frame with Ball Bearing Take-up Unit

Product Features

- Protected screw welded channel frame
- Corrosion-resistant powder coating
- Cast iron housing
- Broad range of sealing options
- Wide inner ring for increased shaft stability
- Spring locking setscrew mount
- Alignable & relubricatable
- See Features and Benefits for additional info on pages 286 - 287.



Bearing Dimensions

Size Code	Shaft Diameter	Adjust. Length	Part Number	A Base to Centerline Height	B Frame Bolt Hole Spacing	C	D	E	F Bolts	H	J	K	L	R	U	W	Approx. Weight	
205	¹⁵ / ₁₆	6	NT3U215N6*	2 ³ / ₄	10 ⁷ / ₈	12 ¹ / ₄	1 ²³ / ₆₄	1 ³ / ₄	1/2	³ / ₁₆	1 1/2	2 ⁷ / ₁₆	4 ³ / ₁₆	2	⁵ / ₆₄	1 ⁹ / ₃₂	4.50	
	1		NT3U216N6*														25.00	152
206	¹ / ₂	6	NT3U219N6*	3	10 ⁷ / ₈	12 ¹ / ₄	1 ⁹ / ₁₆	1 ³ / ₄	1/2	³ / ₁₆	1 1/2	2 ⁷ / ₁₆	4 ¹¹ / ₁₆	2	⁶ / ₆₄	1 ¹⁵ / ₃₂	5.00	
	³ / ₁₆		NT3U2M30N6*														30.00	152
207	¹ / ₂	9	NT3U223N9*	3 ¹¹ / ₁₆	14 ¹ / ₂	16 ¹ / ₂	1 ⁴⁹ / ₆₄	2 ¹ / ₄	1/2	1/4	2	2 ³ / ₄	5 ⁹ / ₁₆	2 1/2	1 ⁷ / ₆₄	1 ⁹ / ₁₆	9.50	
		12	NT3U223N12*		17 ¹ / ₂	19 ¹ / ₂											10.00	
	³ / ₁₆	229	NT3U2M35N9*	93.70	368.30	419.10	44.85	57.20	12.00	6.40	50.80	69.80	141.30	63.50	28.20	39.70	4.30	
		305	NT3U2M35N12*		444.50	495.30											4.50	
210	¹ / ₂	9	NT3U231N9*	4 ²¹ / ₃₂	16	18 ¹ / ₂	2 ³ / ₃₂	3 ¹ / ₄	⁵ / ₈	⁵ / ₁₆	2 1/2	3 1/2	6 ²⁹ / ₃₂	3	1 ¹⁷ / ₆₄	1 ²⁵ / ₃₂	18.00	
		12	NT3U231N12*		19	21 ¹ / ₂											19.00	
		18	NT3U231N18*		25	27 ¹ / ₂											21.00	
	³ / ₁₆	229	NT3U2M50N9*	118.30	406.40	469.90	53.18	82.60	16.00	7.90	63.50	88.90	175.40	76.20	32.10	45.20	8.10	
		305	NT3U2M50N12*		482.60	546.10											8.55	
	457	NT3U2M50N18*		635.00	698.50												9.50	

Additional Notes

Please call 1-866-REXNORD for availability
 Lubrication fitting tap size, 1/8 in PT
 * N lip seals standard

For the Selection Guide, Load Ratings and Speed Limits, see the Link-Belt 200 Series Ball Bearing Engineering section on pages 290 - 298.

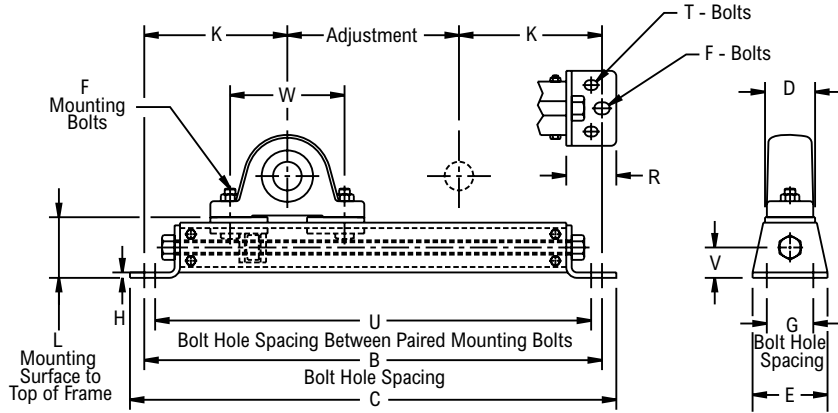
Note: Dimensions subject to change. Certified dimensions of ordered material furnished on request.



Photo Shows a Light Duty Conveyor Take-up Frame

Product Features

- Bolted steel frames
- 2 or 4-bolt frame mounting
- Bolt hole centers adjustable
- Pillow blocks not included
- See Features and Benefits for additional info on pages 286 - 287.



Bearing Dimensions

Size Code	Adjust. Length	Part Number	Bolt Hole Spacing			L Mouting Surface to Top of Frame	C	D	E	F Bolts	H	K	R	T Bolts	V	W min	W max	Approx. Weight
			B Frame	G Width Direction	U Between Pairs													
205	6	LC16	16	1 5/8	15 1/4	2 1/8	17	1 3/4	2 5/8	3/8	3/16	5	1 3/4	5/16	1 1/16	3	5 15/16	5.25
	9	LC19	19		18 1/4		20											6.30
	12	LC112	22		21 1/4		23											6.60
210	6	LC26	19 1/8	2 1/8	18 1/8	2 11/16	20 1/4	2 3/8	3 1/8	1/2	1/4	6 9/16	2 3/16	3/8	1 11/32	3 3/4	7 1/4	10.00
	9	LC29	22 1/8		21 1/8		23 1/4											10.20
	12	LC212	25 1/8		24 1/8		26 1/4											11.50
	18	LC218	31 1/8		30 1/8		32 1/4											13.80
211/212	9	LC39	25 5/16	2 3/4	24 1/16	3 5/16	26 9/16	3	4	5/8	5/16	8 5/32	2 3/4	1/2	1 5/8	4 1/4	9	20.40
	12	LC312	28 5/16		27 1/16		29 9/16											22.25
	18	LC318	34 5/16		33 1/16		35 9/16											26.50
	24	LC324	40 5/16		39 1/16		41 9/16											33.00

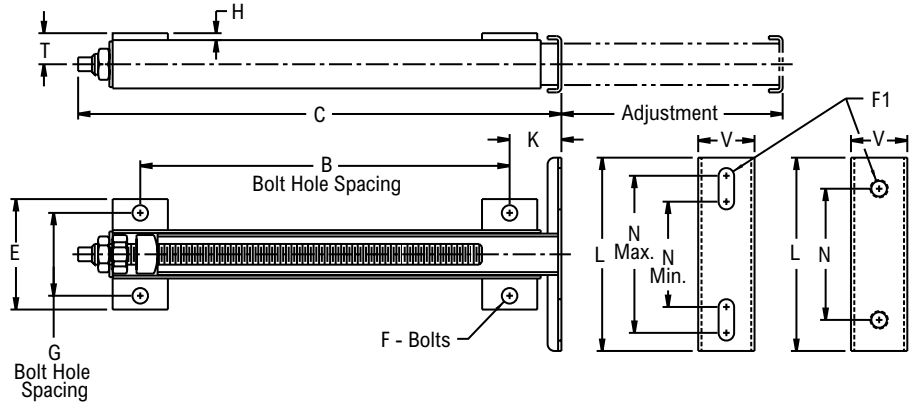
Additional Notes

Please call 1-866-REXNORD for availability
 For pillow block dimensions, see Pillow Block Ball Bearing section
 Note: Dimensions subject to change. Certified dimensions of ordered material furnished on request.

TP, TPT, TSP, TSPT



Photo Shows a T-Frame Protected Screw Take-up Frame for Ball Bearing Pillow Block Mounting



Product Features

- Protected screw T-frame take-up
- Mild steel or AISI 304 stainless steel frame
- Pillow block or tapped base pillow block mounting
- Pillow blocks not included
- See Features and Benefits for additional info on pages 286 - 287.

Bearing Dimensions

Size Code	Adjust. Length	Mild Steel		Stainless Steel		Bolt Hole Spacing		Mounting Plate Bolt Hole Spacing			C	E	F	F1	H	K	L	T	V	Adjust. Screw		
		Part Number	Approx. Weight	Part Number	Approx. Weight	B	G Width Direction	N	N min.	N max										Sq. Drive	Thread Size	
																						N
Pillow Block Mounting																						
203-205	3	TP1003	3.00	TSP1003	2.60	3 9/16	2 5/8	-	2 15/16	4 5/16	6 7/8	1 1/2	3/8	3/8	1/4	1 1/2	5 1/4	3 11/16	7/8	3/8	5/8 - 11	
	6	TP1006	4.00	TSP1006	3.50	7 1/16					10 3/8											14 3/8
	9	TP1009	5.10	TSP1009	4.40	11 1/16					17 1/2											14 3/8
206-209	12	TP25012	9.90	TSP25012	8.10	13 3/8	3	-	3 13/16	5 11/16	8 1/2	2 1/32	1/2	1/2	1/4	1 7/8	7	4	1 1/8	1/2	3/4 - 10	
	3	TP2503	5.80	TSP2503	4.80	4 3/8					11 1/2											14 1/2
	6	TP2506	7.10	TSP2506	5.80	7 3/8					11 1/2											14 1/2
210-212	9	TP2509	8.40	TSP2509	7.00	10 3/8	4	-	5 9/16	8 11/16	19 1/8	2 27/32	5/8	5/8	1/4	2 1/4	10	5 1/4	1 1/2	1/2	7/8 - 9	
	12	TP30012	16.00	TSP30012	16.50	14 1/8					26 1/8											11 1/2
	18	TP30018	20.40	TSP30018	21.60	21 1/8					11 1/2											15 1/8
213-217	6	TP3006	11.00	TSP3006	11.40	6 1/8	5 1/2	-	8 1/2	11 3/4	27 3/4	3 1/2	3/4	3/4	1/4	3 1/2	14	7 1/2	2 1/8	Pinned Nut	1 1/4 - 7	
	9	TP3009	13.10	TSP3009	13.40	10 1/8					33 3/4											39 3/4
	12	TP40012	42.90	-	-	20					39 3/4											39 3/4
Tapped Base Pillow Block Mounting																						
204-205	3	TPT1003	3.00	TSPT1003	2.60	3 9/16	2 5/8	2	-	-	6 7/8	1 1/2	3/8	3/8	1/4	1 1/2	3	3 11/16	7/8	3/8	5/8 - 11	
	6	TPT1006	4.00	TSPT1006	3.50	7 1/16					10 3/8											14 3/8
	9	TPT1009	5.10	TSPT1009	4.40	11 1/16					17 1/2											14 3/8
206	12	TPT250112	9.90	TSPT250112	8.10	13 3/8	3	3	-	-	8 1/2	1 1/2	1/2	7/16	1/4	1 7/8	4	4	1 1/8	1/2	3/4 - 10	
	3	TPT25013	5.80	TSPT25013	4.80	4 3/8					11 1/2											14 1/2
	6	TPT25016	7.10	TSPT25016	5.80	7 3/8					11 1/2											14 1/2
207	9	TPT25019	8.40	TSPT25019	7.00	10 3/8	3	3 1/4	-	-	17 1/2	2	1/2	1/2	1/4	1 7/8	4 1/4	4	1 1/8	1/2	3/4 - 10	
	12	TPT250212	9.90	TSPT250212	8.10	13 3/8					8 1/2											11 1/2
	3	TPT25023	5.80	TSPT25023	4.80	4 3/8					11 1/2											14 1/2
210	6	TPT25026	7.10	TSPT25026	5.80	7 3/8	3	4	-	-	14 1/2	2	1/2	5/8	1/4	1 7/8	5 1/2	4	1 1/8	1/2	3/4 - 10	
	9	TPT25029	8.40	TSPT25029	7.00	10 3/8					8 1/2											11 1/2
	12	TPT250512	9.90	TSPT250512	8.10	13 3/8					11 1/2											14 1/2

Additional Notes

- Please call 1-866-REXNORD for availability
- For pillow block dimensions, see Pillow Block Ball Bearing section
- Note: Dimensions subject to change. Certified dimensions of ordered material furnished on request.

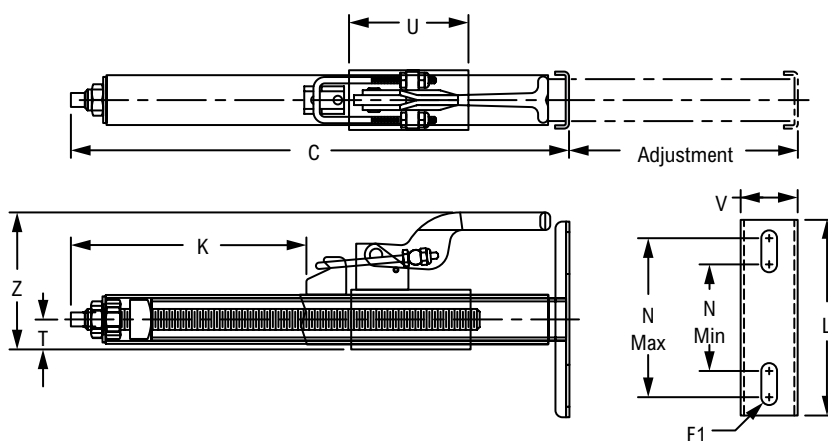
TQP



Photo Shows a T-Frame Quick Release Take-up Frame for Ball Bearing Pillow Block Mounting

Product Features

- Protected screw T-frame take-up
- AISI 304 stainless steel frame
- Pillow block mounting
- Pillow blocks not included
- See Features and Benefits for additional info on pages 286 - 287.



Bearing Dimensions

Size Code	Adjust. Length	Part Number	Bolt Hole Spacing		C	F1	K	L	T	U	V	Z	Adjust. Screw		Approx. Weight
			N min	N max									Sq Drive	Thread Size	
203-205	6	TQP1006	2 15/16	4 5/16	10 3/8	3/8	3 23/32	5 1/4	3/4	3	1 1/2	3 7/16	3/8	5/8 - 11	4.00
	9	TQP1009	2 15/16	4 5/16	14 3/8	3/8	5 23/32	5 1/4	3/4	5	1 1/2	3 7/16			5.00
206-209	6	TQP2506	3 13/16	5 11/16	11 1/2	1/2	1 9/16	7	1	4	2 1/32	4 7/8	1/2	3/4 - 10	7.00
	9	TQP2509	3 13/16	5 11/16	14 1/2	1/2	3 1/16	7	1	6	2 1/32	4 7/8			8.20
	12	TQP25012	3 13/16	5 11/16	17 1/2	1/2	4 9/16	7	1	8	2 1/32	4 7/8			9.50

Additional Notes

Please call 1-866-REXNORD for availability
 For pillow block dimensions, see Pillow Block Ball Bearing section
 Note: Dimensions subject to change. Certified dimensions of ordered material furnished on request.

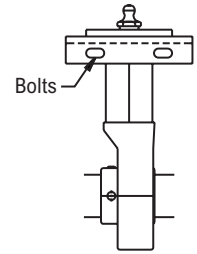
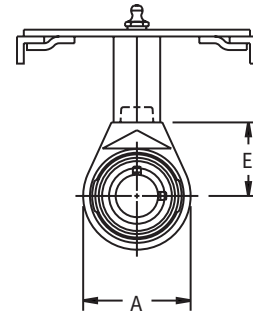
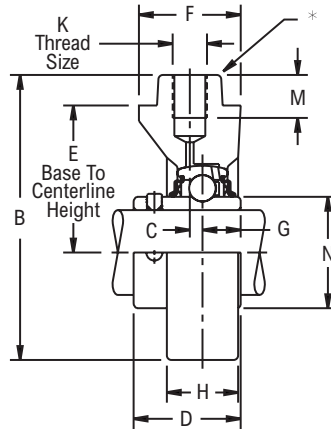
HM3U200



Photo Shows a Screw Conveyor Hanger Ball Bearing Unit

Product Features

- Corrosion-resistant powder coating
- High test iron housing
- Broad range of sealing options
- Wide inner ring for increased shaft stability
- Spring locking setscrew mount
- Alignable & relubricatable
- See Features and Benefits for additional info on pages 286 - 287.



Typical Installation

Bearing Dimensions

Size Code	Shaft Diameter	Part Number	E Base to Centerline Height	K Thread Size	A	B	C	D	F	G	H	M	N	Approx. Weight
208	1 1/2	HM3U224N*Δ■	2 1/2	3/4-10 NC	3 7/8	5.19	0.218	1 29/32	1 3/4	0.7340	0.97	1.00	2.083	5.00
210	2	HM3U2E32N*Δ■	2 1/2	3/4-10 NC	4 3/8	5.44	0.170	2 3/32	1 3/4	0.8280	0.91	1.00	2.475	6.30
212	2 7/16	HM3U239N*Δ■	3 5/8	7/8-9 NC	5 1/4	7.00	0.310	2 1/2	2 1/2	0.9380	1.75	1.06	3.012	11.30
215	3	HM3U2E48N*Δ	3 5/8	7/8-9 NC	6 1/8	7.44	0.375	2 7/8	2 1/2	1.0620	2.00	1.06	3.624	12.90
217	3 7/16	HM3U255N*Δ	4 1/2	1 1/8-12 NF	7 1/2	9.25	0.344	3 9/16	3 9/16	1.4380	2.56	1.88	4.158	24.80

Additional Notes

- Please call 1-866-REXNORD for availability
- Size codes 208 & 210 to fit 1 1/4 in square tubing
- Size codes 212 & 215 to fit 1 3/4 in square tubing
- Size code 217 to fit 2 1/2 in square tubing
- * N lip seals standard
- Available with H labyrinth seals

- Δ Available with E3 triple lip seals
- For the Selection Guide, Load Ratings and Speed Limits, see the Link-Belt 200 Series Ball Bearing Engineering section on pages 290 - 298.
- Note: Dimensions subject to change. Certified dimensions of ordered material furnished on request.

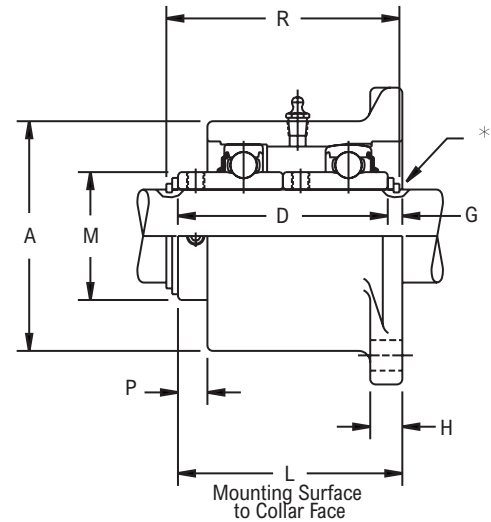
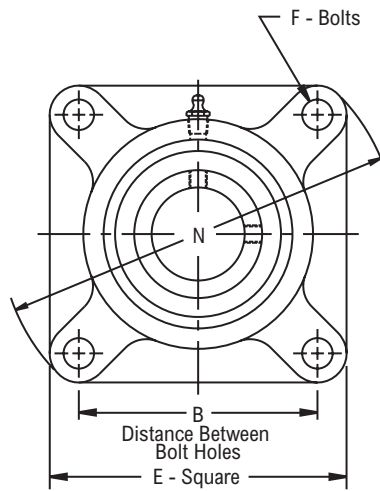
FF200



Photo Shows a 4-Bolt Ball Bearing Screw Conveyor Trough End Flanged Unit

Product Features

- Corrosion-resistant powder coating
- Cast iron housing
- 2 ball bearing inserts in housing
- Spring locking setscrew mount
- Relubricatable
- See Features and Benefits for additional info on pages 286 - 287.



Bearing Dimensions

Size Code	Shaft Diameter	Part Number	Replacement Bearing Number	B Distance Between Bolt Holes	L Mounting Surface to Collar Face	A	D	E	F Bolts	G	H	M	N	P	R	Approx. Weight
208	1 1/2	FF224N*	UR224A	4	4 1/16	4	3 13/16	5 1/8	1/2	1/4	9/16	-	6 25/32	1/2	4 7/32	10.00
	2	FF232N*	UR232A		5 1/8	4 13/16	4 15/16	4 1/2	6 3/8	5/8	5/16	11/16	-	8 1/2	5/8	5 1/32
212	2 7/16	FF239N*	UR239A	5 5/8	5 5/16	5 3/8	5	6 7/8	5/8	5/16	11/16	-	9 7/32	19/32	5 17/32	20.80
	2 3/4	FF244N*	UR244A		6	6 1/16	6 3/8	5 3/4	7 3/4	3/4	5/16	3/4	4 5/8	10 1/4	11/16	6 9/32
215	2 15/16	FF247N*	UR247A	6	6 1/16	6 3/8	5 3/4	7 3/4	3/4	5/16	3/4	4 5/8	10 1/4	11/16	6 9/32	31.10
	3	FF2E48N*	UR2E48A													
217	3 7/16	FF255N*	UR255A	6 3/4	7 5/8	7	7 1/8	8 9/16	3/4	1/2	1	5 3/16	11 3/8	3/4	7 23/32	50.20

Additional Notes

- Please call 1-866-REXNORD for availability
- Lubrication fitting tap size: for size codes 212 and below, 1/4 in PT; for all other size codes, 3/8 in PT
- Support thrust load (preferably in shear) with heavy duty snap ring and square face washer
- Includes two bearings with seals and inner ring setscrews or collar with setscrews

* N lip seals standard

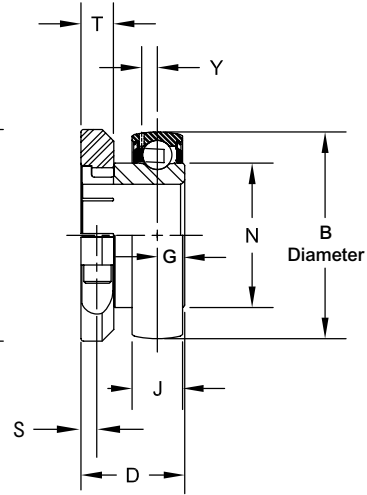
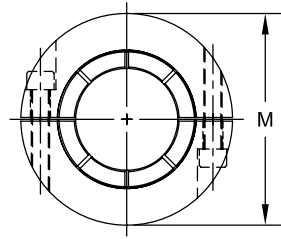
For the Selection Guide, Load Ratings and Speed Limits, see the Link-Belt 200 Series Ball Bearing Engineering section on pages 290 - 298.

Note: Dimensions subject to change. Certified dimensions of ordered material furnished on request.

CLG200NL



Photo Shows an Unmounted Ball Bearing Unit



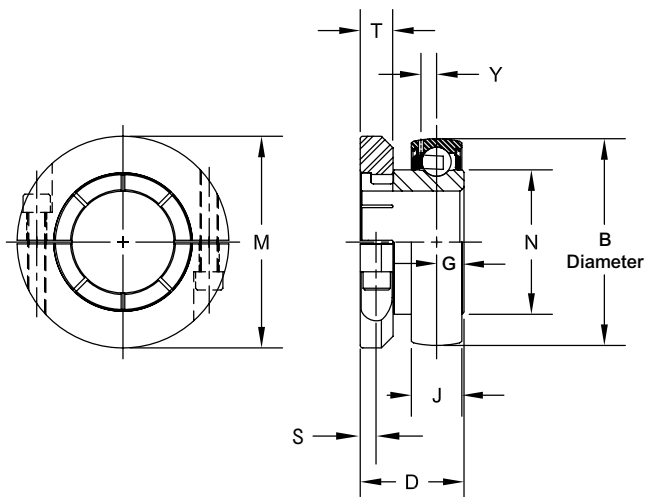
Product Features

- Broad range of sealing options
- Wide inner ring for increased shaft stability
- Spring locking setscrew mount
- Sealed & relubricatable
- Spherical O.D.
- See Features and Benefits for additional info on pages 286 - 287.

Bearing Dimensions

Size Code	Shaft Diameter	Spherical		B O.D.	D	G	M Collar O.D.	N	S	T		Y	Approx. Weight
		Part Number	J Outer Ring Width							Width	Tap		
203	1/2	CLG2B08NL*■	0.5118	1.5748	1 5/32	0.4531	1 5/8	0.941	0.15	9/32	#8-32	0.158	0.25
	5/8	CLG210NL*■											
	11/16	CLG211NL*■											
	17.00	CLG2M17NL*■	13.0000	40.0000	29.37	11.5090	41.28	23.900	3.80			4.010	0.10
204	3/4	CLG212NL*■	0.5906	1.8504	1 5/16	0.5313	2 1/16	1.121	0.19	23/64	#10-32	0.176	0.50
	20.00	CLG2M20NL*■	15.0000	47.0000	33.34	13.4940	52.39	28.470	4.80			4.470	0.20
205	7/8	CLG214NL*▲	0.5906	2.0472	1 29/64	0.5625	2 13/64	1.313	0.22	23/64	#10-32	0.176	0.50
	15/16	CLG215NL*▲											
	1	CLG216NL*▲											
	25.00	CLG2M25NL*▲											
206	1 1/8	CLG218NL*▲	0.7087	2.4409	1 17/32	0.6094	2 19/32	1.587	0.22	23/64	#10-32	0.202	0.80
	1 3/16	CLG219NL*▲											
	1 1/4	CLG2E20NL*▲											
	30.00	CLG2M30NL*▲											
207	1 1/4	CLG220NL*▲	0.7480	2.8346	1 47/64	0.6563	3 3/64	1.847	0.25	7/16	#1/4-28	0.239	1.20
	1 3/8	CLG222NL*▲											
	1 7/16	CLG223NL*▲											
	35.00	CLG2M35NL*▲											
208	1 1/2	CLG224NL*▲	0.8661	3.1496	1 31/32	0.7344	3 3/16	2.083	0.32	7/16	#1/4-28	0.253	1.50
	40.00	CLG2M40NL*▲	22.0000	80.0000	50.01	18.6530	80.96	52.910	8.10			6.430	0.70
209	1 5/8	CLG226NL*▲	0.8661	3.3465	1 31/32	0.7969	3 3/8	2.281	0.32	7/16	#1/4-28	0.254	2.00
	1 11/16	CLG227NL*▲											
	1 3/4	CLG228NL*▲											
	45.00	CLG2M45NL*▲											
210	1 15/16	CLG231NL*▲	0.8661	3.5433	2 5/64	0.8281	3 3/4	2.475	0.38	9/16	#3/8-24	0.268	2.20
	2	CLG2E32NL*▲											
	50.00	CLG2M50NL*▲											

Continued...



Continued...

Bearing Dimensions

Size Code	Shaft Diameter	Spherical		B O.D.	D	G	M Collar O.D.	N	S	T		Y	Approx. Weight
		Part Number	J Outer Ring Width							Width	Tap		
211	2	CLG232NL* Δ	0.9843	3.9370	2 ¹⁵ / ₆₄	0.8438	4 ⁵ / ₆₄	2.749	0.38	9/16	#3/8-24	0.295	2.40
	2 ³ / ₁₆	CLG235NL* Δ										7.490	1.10
	55.00	CLG2M55NL* Δ										25.0000	100.0000
212	2 ¹ / ₄	CLG236NL* Δ	1.0630	4.3307	2 ¹⁹ / ₃₂	0.9375	4 ⁹ / ₃₂	3.012	0.38	9/16	#3/8-24	0.330	3.40
	2 ³ / ₈	CLG238NL* Δ										8.380	1.50
	60.00	CLG2M60NL* Δ										27.0000	110.0000
213	2 ¹ / ₂	CLG240NL* Δ	1.0630	4.7244	2 ³ / ₄	1.0000	4 ⁵ / ₆₄	3.331	-	3/4	#3/8-24	0.343	5.80
	2 ¹¹ / ₁₆	CLG243NL* Δ										8.710	2.60
	65.00	CLG2M65NL* Δ										27.0000	120.0000
215	2 ³ / ₄	CLG244NL* Δ	1.1417	5.1181	2 ⁵⁹ / ₆₄	1.0625	5 ¹ / ₄	3.624	-	3/4	#3/8-24	0.367	7.30
	2 ¹⁵ / ₁₆	CLG247NL* Δ										9.320	3.30
	75.00	CLG2M75NL* Δ										29.0000	130.0000
217	3 ⁷ / ₁₆	CLG255NL* Δ	1.3386	5.9055	3 ³⁹ / ₆₄	1.4375	5 ²³ / ₃₂	4.158	-	3/4	#3/8-24	0.415	9.50
	3 ¹ / ₂	CLG2E56NL* Δ										10.540	4.30
	85.00	CLG2M85NL* Δ										34.0000	150.0000
220	3 ¹⁵ / ₁₆	CLG263NL*	1.5748	7.0866	4 ⁷ / ₆₄	1.6719	6 ¹ / ₂	4.913	-	3/4	#3/8-24	0.504	16.00
	4	CLG2E64NL*										12.800	7.20
	100.00	CLG2M100NL*										40.0000	180.0000

Additional Notes

Please call 1-866-REXNORD for availability

Bearing O.D. tolerance for size code 208 and below, +.0000 in/-.0005 in
(+0.000 mm/-0.013 mm)

Bearing O.D. tolerance for size codes 209 thru 214, +.0000 in/-.0006 in
(+0.000 mm/-0.015 mm)

Bearing O.D. tolerance for size codes 215 thru 217, +.0000 in/-.0008 in
(+0.000 mm/-0.020 mm)

Bearing O.D. tolerance for all other size codes, +.0000 in/-.0010 in
(+0.000 mm/-0.025 mm)

* N lip seals with flingers standard

■ Available with H labyrinth seals

Δ Available with E3 triple lip seals

For the Selection Guide, Load Ratings and Speed Limits, see the Link-Belt 200 Series Ball Bearing Engineering section on pages 290 - 298.

Note: Dimensions subject to change. Certified dimensions of ordered material furnished on request.

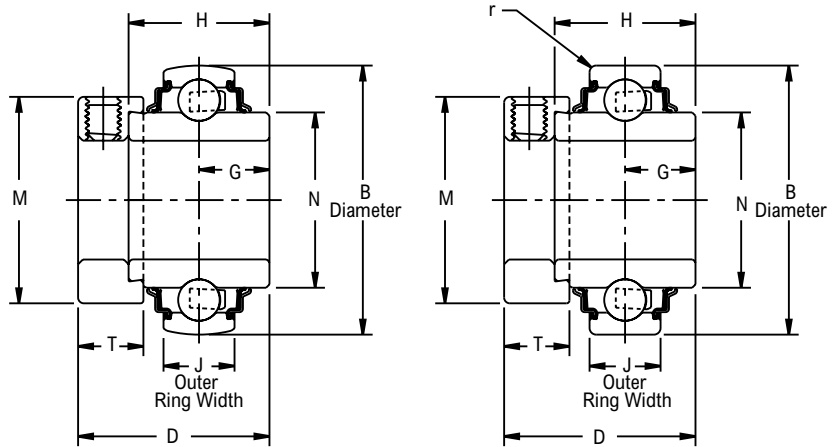
Y200, YB200



Photo Shows an Unmounted Ball Bearing Unit

Product Features

- Broad range of sealing options
- Wide inner ring for increased shaft stability
- Eccentric cam locking device
- Sealed & non-relubricatable
- Spherical or Cylindrical O.D.
- See Features and Benefits for additional info on pages 286 - 287.



Bearing Dimensions

Size Code	Shaft Diameter	Cylindrical		Spherical		B O.D.	D	G	H	M	N	r	T	Approx. Weight
		Part Number	J Outer Ring Width	Part Number	J Outer Ring Width									
203	1/2	YB2B08NL* \blacksquare	0.4724	Y2B08NL* \blacksquare	0.5118	1.5748	1 15/32	0.5469	1.0938	1 1/8	0.941	0.024	17/32	0.30
	5/8	YB210NL* \blacksquare		Y210NL* \blacksquare										
	11/16	YB211NL* \blacksquare		Y211NL* \blacksquare										
204	3/4	YB212NL* \blacksquare	0.5512	Y212NL* \blacksquare	0.5906	1.8504	1 23/32	0.6719	1.3438	1 5/16	1.121	0.039	17/32	0.50
205	7/8	YB214NL* Δ \blacksquare	0.5906	Y214NL* Δ \blacksquare	0.5906	2.0472	1 3/4	0.6875	1.3750	1 1/2	1.313	0.039	17/32	0.70
	15/16	YB215NL* Δ \blacksquare		Y215NL* Δ \blacksquare										
	1	YB216NL* Δ \blacksquare		Y216NL* Δ \blacksquare										
206	1 1/8	YB218NL* Δ \blacksquare	0.6299	Y218NL* Δ \blacksquare	0.7087	2.4409	1 29/32	0.7188	1.4375	1 3/4	1.587	0.039	5/8	0.90
	1 3/16	YB219NL* Δ \blacksquare		Y219NL* Δ \blacksquare										
	1 1/4	YB2E20NL* Δ \blacksquare		Y2E20NL* Δ \blacksquare										
207	1 1/4	YB220NL* Δ \blacksquare	0.6693	Y220NL* Δ \blacksquare	0.7480	2.8346	2 1/64	0.7422	1.4844	2 3/16	1.847	0.039	11/16	1.55
	1 3/8	YB222NL* Δ \blacksquare		Y222NL* Δ \blacksquare										
	1 7/16	YB223NL* Δ \blacksquare		Y223NL* Δ \blacksquare										
208	1 1/2	YB224NL* Δ \blacksquare	0.7087	Y224NL* Δ \blacksquare	0.8661	3.1496	2 7/32	0.8438	1.6875	2 3/8	2.083	0.039	23/32	1.90
209	1 5/8	YB226NL* Δ \blacksquare	0.7480	Y226NL* Δ \blacksquare	0.8661	3.3465	2 7/32	0.8438	1.6875	2 1/2	2.281	0.039	23/32	2.10
	1 11/16	YB227NL* Δ \blacksquare		Y227NL* Δ \blacksquare										
	1 3/4	YB228NL* Δ \blacksquare		Y228NL* Δ \blacksquare										
210	1 15/16	YB231NL* Δ \blacksquare	0.7874	Y231NL* Δ \blacksquare	0.8661	3.5433	2 15/32	0.9688	1.9375	2 3/4	2.475	0.039	23/32	2.10
	2	YB2E32NL* Δ \blacksquare		Y2E32NL* Δ \blacksquare										
211	2	YB232NL* Δ \blacksquare	0.8268	Y232NL* Δ \blacksquare	0.9843	3.9370	2 13/16	1.0938	2.1875	3	2.749	0.059	13/16	3.40
	2 3/16	YB235NL* Δ \blacksquare		Y235NL* Δ \blacksquare										
	2 1/4	YB236NL* Δ \blacksquare		Y236NL* Δ \blacksquare										
212	2 3/8	YB238NL* Δ \blacksquare	0.8661	Y238NL* Δ \blacksquare	1.0630	4.3307	3 1/16	1.2188	2.4375	3 1/4	3.012	0.059	7/8	3.80
	2 7/16	YB239NL* Δ \blacksquare		Y239NL* Δ \blacksquare										

Additional Notes

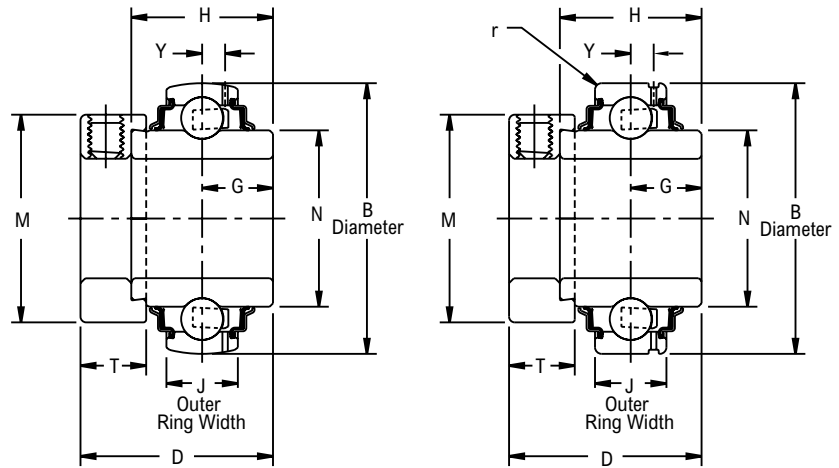
- Please call 1-866-REXNORD for availability
- Dimension "r", max fillet radius of housing to clear bearing corner
- Bearing O.D. tolerance for size code 208 and below, +.0000 in/-.0005 in (+0.000 mm/-0.013 mm); for all other size codes, +.0000 in/-.0006 in (+0.000 mm/-0.015 mm)
- * N lip seals standard
- \blacksquare Available with H labyrinth seals

- Δ Available with E3 triple lip seals
- For the Selection Guide, Load Ratings and Speed Limits, see the Link-Belt 200 Series Ball Bearing Engineering section on pages 290 - 298.
- Note: Dimensions subject to change. Certified dimensions of ordered material furnished on request.

YG200, YBG200



Photo Shows an Unmounted Ball Bearing Unit



Product Features

- Broad range of sealing options
- Wide inner ring for increased shaft stability
- Eccentric cam locking device
- Sealed & relubricatable
- Spherical or Cylindrical O.D.
- See Features and Benefits for additional info on pages 286 - 287.

Bearing Dimensions

Size Code	Shaft Diameter	Cylindrical		Spherical		B O.D.	D	G	H	M	N	r	T	Y	Approx. Weight
		Part Number	J Outer Ring Width	Part Number	J Outer Ring Width										
203	1/2	YBG2B08NL*■	0.4724	YG2B08NL*■	0.5118	1.5748	1 15/32	0.5469	1.0938	1 1/8	0.941	0.024	17/32	0.158	0.30
	5/8	YBG210NL*■		YG210NL*■											
	11/16	YBG211NL*■		YG211NL*■											
204	3/4	YBG212NL*■	0.5512	YG212NL*■	0.5906	1.8504	1 23/32	0.6719	1.3438	1 5/16	1.121	0.039	17/32	0.176	0.50
205	7/8	YBG214NL*Δ	0.5906	YG214NL*Δ	0.5906	2.0472	1 3/4	0.6875	1.3750	1 1/2	1.313	0.039	17/32	0.176	0.70
	15/16	YBG215NL*Δ		YG215NL*Δ											
	1	YBG216NL*Δ		YG216NL*Δ											
206	1 1/8	YBG218NL*Δ	0.7087	YG218NL*Δ	0.7087	2.4409	1 29/32	0.7188	1.4375	1 3/4	1.587	0.039	5/8	0.202	0.90
	1 3/16	YBG219NL*Δ		YG219NL*Δ											
	1 1/4	YBG2E20NL*Δ		YG2E20NL*Δ											
207	1 1/4	YBG220NL*Δ	0.7480	YG220NL*Δ	0.7480	2.8346	2 1/64	0.7422	1.4844	2 3/16	1.847	0.039	11/16	0.239	1.55
	1 3/8	YBG222NL*Δ		YG222NL*Δ											
	1 7/16	YBG223NL*Δ		YG223NL*Δ											
208	1 1/2	YBG224NL*Δ	0.8268	YG224NL*Δ	0.8661	3.1496	2 7/32	0.8438	1.6875	2 3/8	2.083	0.039	23/32	0.253	1.90
	1 5/8	YBG226NL*Δ	0.8661	YG226NL*Δ	0.8661	3.3465	2 7/32	0.8438	1.6875	2 1/2	2.281	0.039	23/32	0.254	2.10
209	1 11/16	YBG227NL*Δ	0.8661	YG227NL*Δ	0.8661	3.5433	2 15/32	0.9688	1.9375	2 3/4	2.475	0.039	23/32	0.268	2.10
	1 3/4	YBG228NL*Δ		YG228NL*Δ											
	1 15/16	YBG231NL*Δ		YG231NL*Δ											
210	2	YBG2E32NL*Δ	0.9055	YG2E32NL*Δ	0.8661	3.5433	2 15/32	0.9688	1.9375	2 3/4	2.475	0.039	23/32	0.268	2.10
	2	YBG232NL*Δ		YG232NL*Δ											
	2 3/16	YBG235NL*Δ		YG235NL*Δ											
211	2 3/16	YBG235NL*Δ	0.9843	YG235NL*Δ	0.9843	3.9370	2 13/16	1.0938	2.1875	3	2.749	0.059	13/16	0.295	3.40
	2 1/4	YBG236NL*Δ		YG236NL*Δ											
	2 3/8	YBG238NL*Δ		YG238NL*Δ											
212	2 3/8	YBG238NL*Δ	1.0630	YG238NL*Δ	1.0630	4.3307	3 1/16	1.2188	2.4375	3 1/4	3.012	0.059	7/8	0.330	3.80
	2 7/16	YBG239NL*Δ		YG239NL*Δ											

Additional Notes

- Please call 1-866-REXNORD for availability
- Dimension "r", max fillet radius of housing to clear bearing corner
- Bearing O.D. tolerance for size code 208 and below, +.0000 in/-0.0005 in (+0.000 mm/-0.013 mm); for all other size codes, +.0000 in/-0.0006 in (+0.000 mm/-0.015 mm)
- * N lip seals standard
- Available with H labyrinth seals

Δ Available with E3 triple lip seals

For the Selection Guide, Load Ratings and Speed Limits, see the Link-Belt 200 Series Ball Bearing Engineering section on pages 290 - 298.

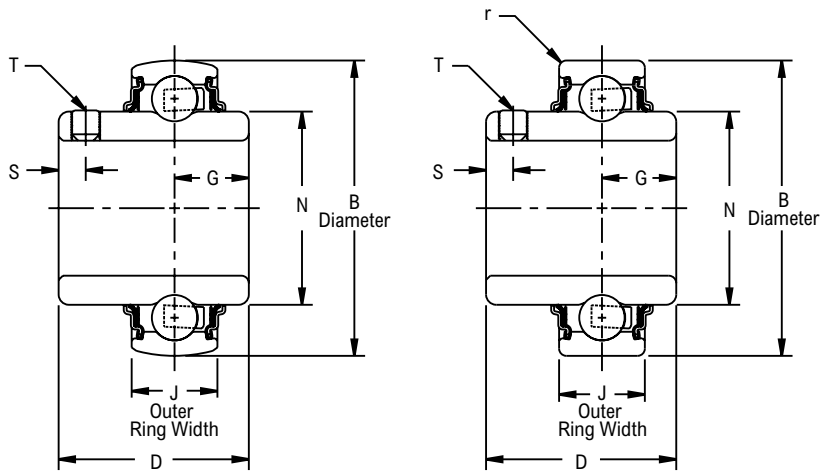
Note: Dimensions subject to change. Certified dimensions of ordered material furnished on request.



Photo Shows an Unmounted Ball Bearing Unit

Product Features

- Broad range of sealing options
- Wide inner ring for increased shaft stability
- Spring locking setscrew mount
- Sealed & non-relubricatable
- Spherical or Cylindrical O.D.
- See Features and Benefits for additional info on pages 286 - 287.



Bearing Dimensions

Size Code	Shaft Diameter	Cylindrical		Spherical		B O.D.	D	G	N	r	S	T	Approx. Weight
		Part Number	J Outer Ring Width	Part Number	J Outer Ring Width								
203	1/2	UB2B08NL*■	0.4724	U2B08NL*■	0.5118	1.5748	1 3/32	0.4531	0.941	0.024	0.15	#10-32	0.25
	5/8	UB210NL*■		U210NL*■									
	11/16	UB211NL*■		U211NL*■									
	17.00	UB2M17NL*■	12.0000	U2M17NL*■	13.0000	40.0000	27.78	11.5090	23.900	0.610	3.80	#10-32	0.10
204	3/4	UB212NL*■	0.5512	U212NL*■	0.5906	1.8504	1 9/32	0.5313	1.121	0.039	0.19	#1/4-28	0.50
	20.00	UB2M20NL*■	14.0000	U2M20NL*■	15.0000	47.0000	32.54	13.4940	28.470	1.000	4.80	#1/4-28	0.20
205	7/8	UB214NL*Δ	0.5906	U214NL*Δ	0.5906	2.0472	1 29/64	0.5625	1.313	0.039	0.22	#1/4-28	0.50
	15/16	UB215NL*Δ		U215NL*Δ									
	1	UB216NL*Δ		U216NL*Δ									
	25.00	UB2M25NL*Δ		15.0000									
206	1 1/8	UB218NL*Δ	0.6299	U218NL*Δ	0.7087	2.4409	1 9/16	0.6094	1.587	0.039	0.22	#1/4-28	0.80
	1 3/16	UB219NL*Δ		U219NL*Δ									
	1 1/4	UB2E20NL*Δ		U2E20NL*Δ									
	30.00	UB2M30NL*Δ		16.0000									
207	1 1/4	UB220NL*Δ	0.6693	U220NL*Δ	0.7480	2.8346	1 49/64	0.6563	1.847	0.039	0.25	#5/16-24	1.20
	1 3/8	UB222NL*Δ		U222NL*Δ									
	1 7/16	UB223NL*Δ		U223NL*Δ									
	35.00	UB2M35NL*Δ	17.0000	U2M35NL*Δ	19.0000	72.0000	44.85	16.6690	46.910	1.000	6.40	#5/16-24	0.55
208	1 1/2	UB224NL*Δ	0.7087	U224NL*Δ	0.8661	3.1496	1 29/32	0.7344	2.083	0.039	0.32	#5/16-24	1.50
	40.00	UB2M40NL*Δ	18.0000	U2M40NL*Δ	22.0000	80.0000	48.42	18.6530	52.910	1.000	8.10	#5/16-24	0.70
209	1 5/8	UB226NL*Δ	0.7480	U226NL*Δ	0.8661	3.3465	2 1/32	0.7969	2.281	0.039	0.32	#5/16-24	2.00
	1 11/16	UB227NL*Δ		U227NL*Δ									
	1 3/4	UB228NL*Δ		U228NL*Δ									
	45.00	UB2M45NL*Δ		19.0000									
210	1 15/16	UB231NL*Δ	0.7874	U231NL*Δ	0.8661	3.5433	2 3/32	0.8261	2.475	0.039	0.38	#3/8-24	2.20
	2	UB2E32NL*Δ		U2E32NL*Δ									
	50.00	UB2M50NL*Δ		20.0000									
211	2	UB232NL*Δ	0.8268	U232NL*Δ	0.9843	3.9370	2 1/4	0.8438	2.749	0.059	0.38	#3/8-24	2.40
	2 3/16	UB235NL*Δ		U235NL*Δ									
	55.00	UB2M55NL*Δ		21.0000									
212	2 1/4	UB236NL*Δ	0.8661	U236NL*Δ	1.0630	4.3307	2 1/2	0.9375	3.012	0.059	0.38	#3/8-24	3.40
	2 3/8	UB238NL*Δ		U238NL*Δ									
	2 7/16	UB239NL*Δ		U239NL*Δ									
	60.00	UB2M60NL*Δ		22.0000									

Additional Notes

- Please call 1-866-REXNORD for availability
- Dimension "r", max fillet radius of housing to clear bearing corner
- Bearing O.D. tolerance for size code 208 and below, +.0000 in/-0.0005 in (+0.000 mm/-0.013 mm); for all other size codes, +.0000 in/-0.0006 in (+0.000 mm/-0.015 mm)
- * N lip seals standard
- Available with H labyrinth seals

- Δ Available with E3 triple lip seals
- For the Selection Guide, Load Ratings and Speed Limits, see the Link-Belt 200 Series Ball Bearing Engineering section on pages 290 - 298.
- Note: Dimensions subject to change. Certified dimensions of ordered material furnished on request.

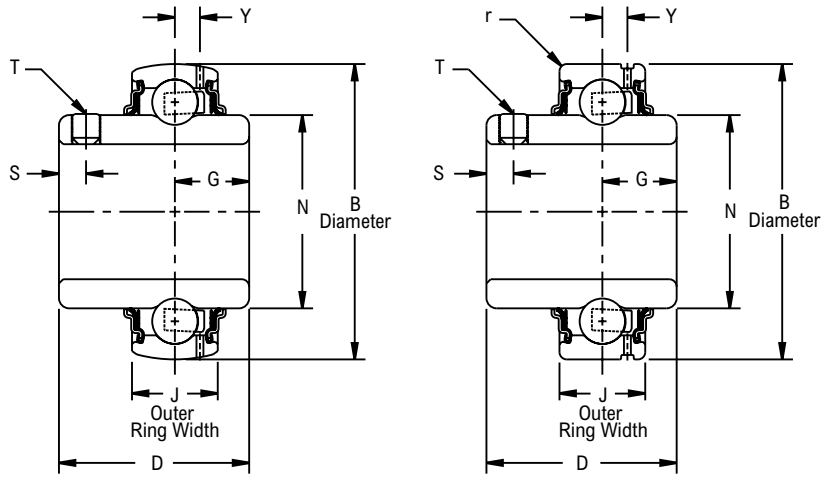
UG200, UBG200



Photo Shows an Unmounted Ball Bearing Unit

Product Features

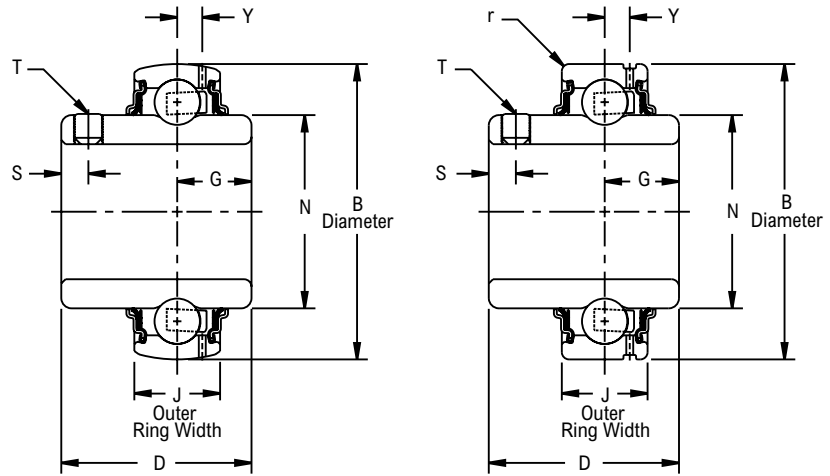
- Broad range of sealing options
- Wide inner ring for increased shaft stability
- Spring locking setscrew mount
- Sealed & relubricatable
- Spherical or Cylindrical O.D.
- See Features and Benefits for additional info on pages 286 - 287.



Bearing Dimensions

Size Code	Shaft Diameter	Cylindrical		Spherical		B O.D.	D	G	M	N	r	S	T	Y	Approx. Weight	
		Part Number	J Outer Ring Width	Part Number	J Outer Ring Width											
203	1/2	UBG2B08NL* \blacksquare	0.4724	UG2B08NL* \blacksquare	0.5118	1.5748	1 3/32	0.4531	-	0.941	0.024	0.15	#10-32	0.158	0.25	
	5/8	UBG210NL* \blacksquare														UG210NL* \blacksquare
	11/16	UBG211NL* \blacksquare														UG211NL* \blacksquare
	17.00	UBG2M17NL*\blacksquare	12.0000	UG2M17NL*\blacksquare	13.0000	40.0000	27.78	11.5090	-	23.900	0.610	3.80	#10-32	4.010	0.10	
204	3/4	UBG212NL* \blacksquare	0.5512	UG212NL* \blacksquare	0.5906	1.8504	1 9/32	0.5313	-	1.121	0.039	0.19	#1/4-28	0.176	0.50	
	20.00	UBG2M20NL*\blacksquare	14.0000	UG2M20NL*\blacksquare	15.0000	47.0000	32.54	13.4940	-	28.470	1.000	4.80	#1/4-28	4.470	0.20	
205	7/8	UBG214NL* Δ	0.5906	UG214NL* Δ	0.5906	2.0472	1 29/64	0.5625	-	1.313	0.039	0.22	#1/4-28	0.176	0.50	
	15/16	UBG215NL* Δ		UG215NL* Δ												
	1	UBG216NL* Δ		UG216NL* Δ												
	25.00	UBG2M25NL*Δ		15.0000												UG2M25NL*Δ
206	1 1/8	UBG218NL* Δ	0.7087	UG218NL* Δ	0.7087	2.4409	1 9/16	0.6094	-	1.587	0.039	0.22	#1/4-28	0.202	0.80	
	1 3/16	UBG219NL* Δ		UG219NL* Δ												
	1 1/4	UBG2E20NL* Δ		UG2E20NL* Δ												
	30.00	UBG2M30NL*Δ		18.0000												UG2M30NL*Δ
207	1 1/4	UBG220NL* Δ	0.7480	UG220NL* Δ	0.7480	2.8346	1 49/64	0.6563	-	1.847	0.039	0.25	#5/16-24	0.239	1.20	
	1 3/8	UBG222NL* Δ		UG222NL* Δ												
	1 7/16	UBG223NL* Δ		UG223NL* Δ												
	35.00	UBG2M35NL*Δ		19.0000												UG2M35NL*Δ
208	1 1/2	UBG224NL* Δ	0.8268	UG224NL* Δ	0.8661	3.1496	1 29/32	0.7344	-	2.083	0.039	0.32	#5/16-24	0.253	1.50	
	40.00	UBG2M40NL*Δ	21.0000	UG2M40NL*Δ	22.0000	80.0000	48.42	18.6530	-	52.910	1.000	8.10	#5/16-24	6.430	0.70	
209	1 5/8	UBG226NL* Δ	0.8661	UG226NL* Δ	0.8661	3.3465	2 1/32	0.7969	-	2.281	0.039	0.32	#5/16-24	0.254	2.00	
	1 11/16	UBG227NL* Δ		UG227NL* Δ												
	1 3/4	UBG228NL* Δ		UG228NL* Δ												
	45.00	UBG2M45NL*Δ		22.0000												UG2M45NL*Δ
210	1 15/16	UBG231NL* Δ	0.9055	UG231NL* Δ	0.8661	3.5433	2 3/32	0.8281	-	2.475	0.039	0.38	#3/8-24	0.268	2.20	
	2	UBG2E32NL* Δ		UG2E32NL* Δ												
	50.00	UBG2M50NL*Δ		23.0000												UG2M50NL*Δ
211	2	UBG232NL* Δ	0.9843	UG232NL* Δ	0.9843	3.9370	2 1/4	0.8438	-	2.749	0.059	0.38	#3/8-24	0.295	2.40	
	2 3/16	UBG235NL* Δ		UG235NL* Δ												
	55.00	UBG2M55NL*Δ		25.0000												UG2M55NL*Δ
212	2 1/4	UBG236NL* Δ	1.0630	UG236NL* Δ	1.0630	4.3307	2 1/2	0.9375	-	3.012	0.059	0.38	#3/8-24	0.330	3.40	
	2 3/8	UBG238NL* Δ		UG238NL* Δ												
	2 7/16	UBG239NL* Δ		UG239NL* Δ												
	60.00	UBG2M60NL*Δ		27.0000												UG2M60NL*Δ

Continued...



Continued...

Bearing Dimensions

Size Code	Shaft Diameter	Cylindrical		Spherical		B O.D.	D	G	M	N	r	S	T	Y	Approx. Weight
		Part Number	J Outer Ring Width	Part Number	J Outer Ring Width										
213	2 1/2	-	-	UG240NL*Δ	1.0630	4.7244	2 11/16	1.0000	4 3/16	3.331	-	-	-	0.343	5.80
	2 11/16	-	-	UG243NL*Δ											
	65.00	-	-	UG2M65NL*Δ	27.0000	120.0000	68.26	25.4000	106.40	84.610	-	-	-	8.710	2.60
215	2 3/4	-	-	UG244NL*Δ											
	2 15/16	-	-	UG247NL*Δ	1.1417	5.1181	2 7/8	1.0625	4 5/8	3.624	-	-	-	0.367	7.30
	3	-	-	UG2E48NL*Δ											
217	75.00	-	-	UG2M75NL*Δ	29.0000	130.0000	73.02	26.9870	117.50	92.050	-	-	-	9.320	3.30
	3 7/16	-	-	UG255NL*Δ	1.3386	5.9055	3 9/16	1.4375	5 3/16	4.158	-	-	-	0.415	9.50
	3 1/2	-	-	UG2E56NL*Δ											
220	85.00	-	-	UG2M85NL*Δ	34.0000	150.0000	90.49	36.5130	131.80	105.610	-	-	-	10.540	4.30
	3 15/16	-	-	UG263NL*	1.5748	7.0866	4 1/4	1.6719	5 15/16	4.913	-	-	-	0.504	16.00
	4	-	-	UG2E64NL*											
	100.00	-	-	UG2M100NL*	40.0000	180.0000	107.95	42.4660	150.80	124.790	-	-	-	12.800	7.20

Additional Notes

Please call 1-866-REXNORD for availability
 Bearing O.D. tolerance for size code 208 and below,
 +.0000 in/-.0005 in (+0.000 mm/-0.013 mm)
 Bearing O.D. tolerance for size codes 209 thru 214,
 +.0000 in/-.0006 in (+0.000 mm/-0.015 mm)
 Bearing O.D. tolerance for size codes 215 thru 217,
 +.0000 in/-.0008 in (+0.000 mm/-0.020 mm)
 Bearing O.D. tolerance for all other size codes,
 +.0000 in/-.0010 in (+0.000 mm/-0.025 mm)

Dimension "r", max fillet radius of housing to clear bearing corner

* N lip seals standard

■ Available with H labyrinth seals

Δ Available with E3 triple lip seals

For the Selection Guide, Load Ratings and Speed Limits, see the Link-Belt 200 Series Ball Bearing Engineering section on pages 290 - 298.

Note: Dimensions subject to change. Certified dimensions of ordered material furnished on request.

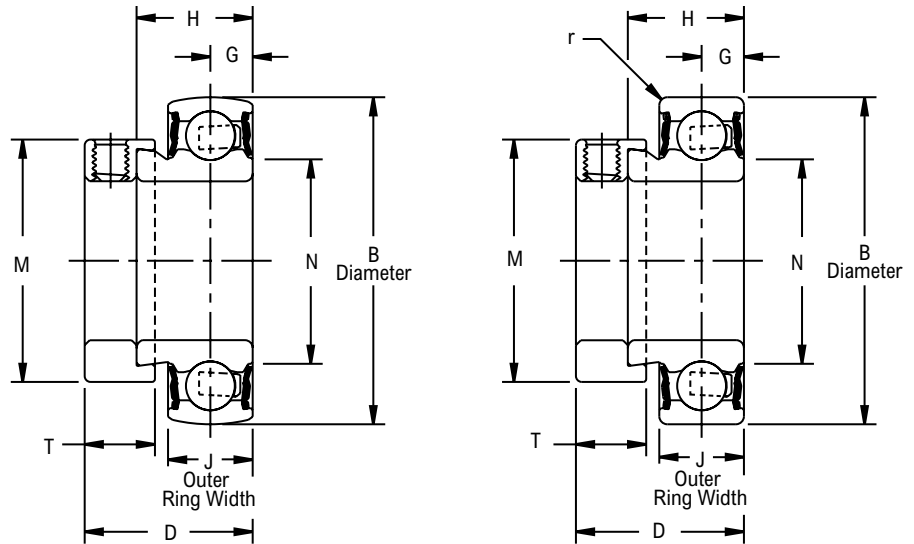
W200, WB200



Photo Shows an Unmounted Ball Bearing Unit

Product Features

- Eccentric cam locking device
- Sealed & non-relubricatable
- Spherical or Cylindrical O.D.
- See Features and Benefits for additional info on pages 286 - 287.



Bearing Dimensions

Size Code	Shaft Diameter	Cylindrical	Spherical	B O.D.	J Outer Ring Width	D	G	H	M	N	r	T	Approx. Weight
		Part Number	Part Number										
203	1/2	WB2B08EL▲	W2B08EL▲	1.5748	0.5118	1 1/8	0.2559	0.7500	1 1/8	0.879	0.024	17/32	0.30
	5/8	WB210EL▲	W210EL▲										
204	3/4	WB212EL▲	W212EL▲	1.8504	0.5906	1 7/32	0.2953	0.8437	1 5/16	1.013	0.039	17/32	0.50
205	7/8	WB214EL▲	W214EL▲	2.0472	0.5906	1 7/32	0.2953	0.8437	1 1/2	1.210	0.039	17/32	0.50
	15/16	WB215EL▲	W215EL▲										
	1	WB216EL▲	W216EL▲										
206	1 1/8	WB218EL▲	W218EL▲	2.4409	0.7087	1 13/32	0.3543	0.9375	1 3/4	1.587	0.039	5/8	0.75
	1 3/16	WB219EL▲	W219EL▲										
	1 1/4	WB2E20EL▲	W2E20EL▲										
207	1 1/4	WB220EL▲	W220EL▲	2.8346	0.7480	1 17/32	0.3740	1.0000	2 3/16	1.847	0.039	11/16	1.30
	1 3/8	WB222EL▲	W222EL▲										
	1 7/16	WB223EL▲	W223EL▲										
208	1 1/2	WB224EL▲	W224EL▲	3.1496	0.8661	1 23/32	0.4330	1.1875	2 3/8	2.083	0.039	23/32	1.60
209	1 5/8	WB226EL▲	W226EL▲	3.3465	0.8661	1 23/32	0.4330	1.1875	2 1/2	2.109	0.039	23/32	1.70
	1 11/16	WB227EL▲	W227EL▲										
	1 3/4	WB228EL▲	W228EL▲										
210	1 15/16	WB231EL▲	W231EL▲	3.5433	0.8661	1 23/32	0.4330	1.1875	2 3/4	2.306	0.039	23/32	1.75
	2	WB2E32EL▲	W2E32EL▲										

Additional Notes

Please call 1-866-REXNORD for availability
 Dimension "r", max fillet radius of housing to clear bearing corner
 Bearing O.D. tolerance for size code 208 and below,
 +.0000 in/- .0005 in (+0.000 mm/-0.013 mm); for all other size codes,
 +.0000 in/- .0006 in (+0.000 mm/-0.015 mm)
 ▲ E lip seals standard

For the Selection Guide, Load Ratings and Speed Limits, see the Link-Belt 200 Series Ball Bearing Engineering section on pages 290 - 298.
 Note: Dimensions subject to change. Certified dimensions of ordered material furnished on request.

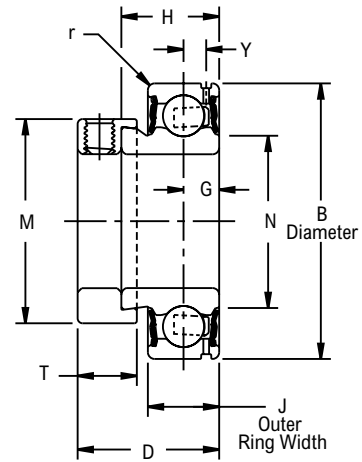
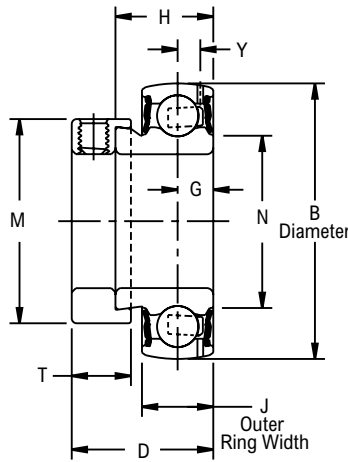
WG200, WBG200



Photo Shows an Unmounted Ball Bearing Unit

Product Features

- Eccentric cam locking device
- Sealed & relubricatable
- Spherical or Cylindrical O.D.
- See Features and Benefits for additional info on pages 286 - 287.



Bearing Dimensions

Size Code	Shaft Diameter	Cylindrical	Spherical	B O.D.	J Outer Ring Width	D	G	H	M	N	r	T	Y	Approx. Weight
		Part Number	Part Number											
203	1/2	WBG2B08EL▲	WG2B08EL▲	1.5748	0.5118	1 1/8	0.2559	0.7500	1 1/8	0.879	0.024	17/32	0.158	0.30
	5/8	WBG210EL▲	WG210EL▲											
204	3/4	WBG212EL▲	WG212EL▲	1.8504	0.5906	1 7/32	0.2953	0.8437	1 5/16	1.013	0.039	17/32	0.176	0.50
205	7/8	WBG214EL▲	WG214EL▲	2.0472	0.5906	1 7/32	0.2953	0.8437	1 1/2	1.210	0.039	17/32	0.176	0.50
	15/16	WBG215EL▲	WG215EL▲											
	1	WBG216EL▲	WG216EL▲											
206	1 1/8	WBG218EL▲	WG218EL▲	2.4409	0.7087	1 13/32	0.3543	0.9375	1 3/4	1.587	0.039	5/8	0.202	0.75
	1 3/16	WBG219EL▲	WG219EL▲											
	1 1/4	WBG2E20EL▲	WG2E20EL▲											
207	1 1/4	WBG220EL▲	WG220EL▲	2.8346	0.7480	1 17/32	0.3740	1.0000	2 3/16	1.847	0.039	11/16	0.239	1.30
	1 3/8	WBG222EL▲	WG222EL▲											
	1 7/16	WBG223EL▲	WG223EL▲											
208	1 1/2	WBG224EL▲	WG224EL▲	3.1496	0.8661	1 23/32	0.4330	1.1875	2 3/8	2.083	0.039	23/32	0.253	1.60
	5/8	WBG226EL▲	WG226EL▲											
209	1 11/16	WBG227EL▲	WG227EL▲	3.3465	0.8661	1 23/32	0.4330	1.1875	2 1/2	2.109	0.039	23/32	0.254	1.70
	3/4	WBG228EL▲	WG228EL▲											
210	1 15/16	WBG231EL▲	WG231EL▲	3.5433	0.8661	1 23/32	0.4330	1.1875	2 3/4	2.306	0.039	23/32	0.268	1.75
	2	WBG2E32EL▲	WG2E32EL▲											

Additional Notes

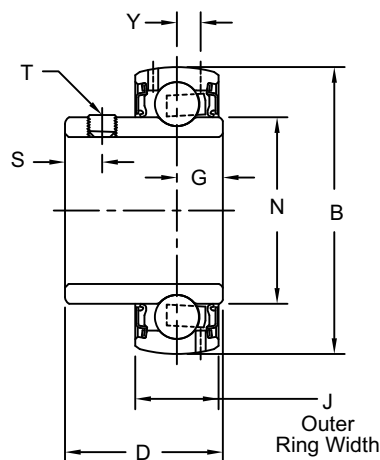
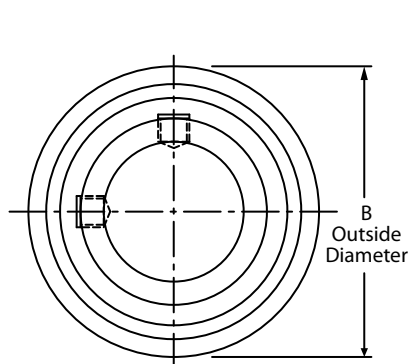
- Please call 1-866-REXNORD for availability
- Dimension "r", max fillet radius of housing to clear bearing corner
- Bearing O.D. tolerance for size code 208 and below, +.0000 in/-0.0005 in (+0.000 mm/-0.013 mm); for all other size codes, +.0000 in/-0.0006 in (+0.000 mm/-0.015 mm)
- ▲ E lip seals standard

For the Selection Guide, Load Ratings and Speed Limits, see the Link-Belt 200 Series Ball Bearing Engineering section on pages 290 - 298.
 Note: Dimensions subject to change. Certified dimensions of ordered material furnished on request.

SG200ELPA



Photo Shows an Unmounted Ball Bearing Unit



Product Features

- Broad range of sealing options
- Spring locking setscrew mount
- Sealed & relubricatable
- Spherical O.D.
- See Features and Benefits for additional info on pages 286 - 287.

Bearing Dimensions

Size Code	Shaft Diameter	Part Number	B O.D.	J Outer Ring Width	D	G	N	S	T	Y	Approx. Weight
203	1/2	SG2B08ELPA◆●□△	1.5748	0.5118	63/64	0.3440	0.941	0.19	#10-32	0.158	0.25
	5/8	SG210ELPA◆●□△									0.21
	11/16	SG211ELPA◆●□△									0.19
204	3/4	SG212ELPA◆●□△	1.8504	0.5906	1 1/8	0.3760	1.121	0.23	1/4-28	0.176	0.32
	20.00	SG2M20ELPA◆●□△	47.0000	15.0000	28.58	9.5500	28.470	5.80	M6X1	4.470	0.10
205	7/8	SG214ELPA◆●□△	2.0472	0.5906	1 11/64	0.3760	1.313	0.25	1/4-28	0.176	0.43
	15/16	SG215ELPA◆●□△									0.40
	1	SG216ELPA◆●□△									0.37
	25.00	SG2M25ELPA◆●□△									52.0000
206	1 1/8	SG218ELPA◆●□△	2.4409	0.7087	1 11/32	0.3920	1.587	0.31	5/16-24	0.202	0.63
	1 3/16	SG219ELPA◆●□△									0.60
	1 1/4	SG2E20ELPA◆●□△									0.57
	30.00	SG2M30ELPA◆●□△	62.0000	18.0000	34.14	9.9600	40.310	7.90	M8X1.25	5.130	0.30
207	1 1/4	SG220ELPA◆●□△	2.8346	0.7480	1 9/16	0.4540	1.847	0.34	5/16-24	0.227	1.02
	1 3/8	SG222ELPA◆●□△									0.92
	1 7/16	SG223ELPA◆●□△									0.86
	35.00	SG2M35ELPA◆●□△	72.0000	19.0000	39.67	11.5300	46.910	8.60	M8X1.25	5.770	0.40
208	1 1/2	SG224ELPA◆●□△	3.1496	0.8661	1 21/32	0.4850	2.083	0.34	5/16-24	0.263	1.27
	1 5/8	SG2E26ELPA◆●□△									1.20
	40.00	SG2M40ELPA◆●□△									80.0000
209	1 5/8	SG226ELPA◆●□△	3.3465	0.8661	1 49/64	0.5320	2.281	0.36	5/16-24	0.256	1.50
	1 11/16	SG227ELPA◆●□△									1.43
	1 3/4	SG228ELPA◆●□△									1.36
210	1 7/8	SG230ELPA◆●□△	3.5433	0.8661	1 13/16	0.5320	2.475	0.38	3/8-24	0.256	1.57
	1 15/16	SG231ELPA◆●□△									1.48
	2	SG2E32ELPA◆●□△									1.39
	2	SG232ELPA◆●□△									2.27
211	2 3/16	SG235ELPA◆●□△	3.9370	0.9843	1 13/16	0.5370	2.749	0.38	3/8-24	0.298	1.97
	2 1/4	SG2E36ELPA◆●□△									1.87
	2 1/4	SG236ELPA◆●□△									2.85
212	2 3/8	SG238ELPA◆●□△	4.3307	1.0630	1 57/64	0.5780	3.012	0.38	3/8-24	0.330	2.61
	2 7/16	SG239ELPA◆●□△									2.49
	2 15/16	SG247ELPA◆●□△									5.1181

Additional Notes

- Please call 1-866-REXNORD for availability
- Bearing O.D. tolerance for size code 203 thru 208, +.0000 in/-.0005 in (+0.000 mm/-0.013 mm); for all other size codes, +.0000 in/-.0006 in (+0.000 mm/-0.015 mm)
- Lip seals standard
- ◆ Available with E1 viton seals for all size codes
- Available with free running style seals, add suffix ● FF, □ HFF or △ MHFF for all size codes

For the Selection Guide, Load Ratings and Speed Limits, see the Link-Belt 200 Series Ball Bearing Engineering section on pages 290 - 298.

Note: Dimensions subject to change. Certified dimensions of ordered material furnished on request.

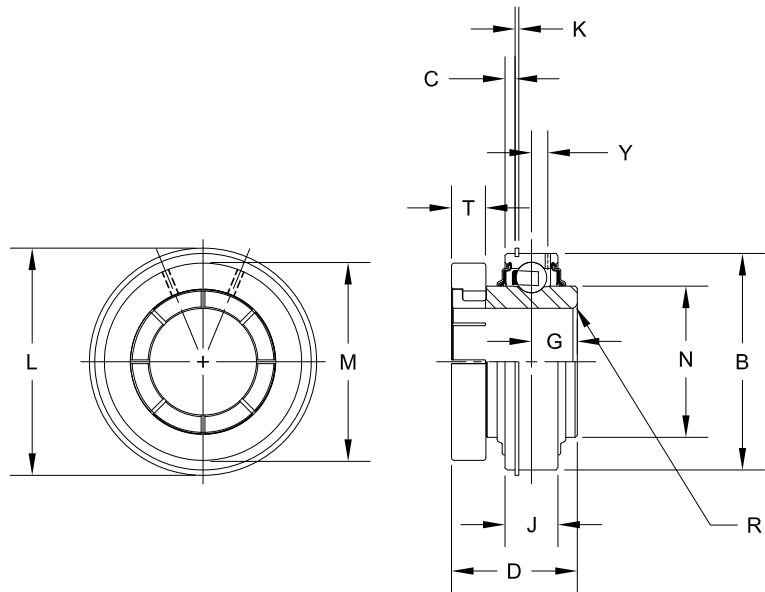
ER-KCL



Photo Shows an ER Adapter Series Ball Bearing Unit

Product Features

- Broad range of sealing options
- Centrik-Lok shaft locking device
- Sealed & relubricatable
- Cylindrical O.D.
- O.D. mounted snap ring
- See Features and Benefits for additional info on pages 286 - 287.



Bearing Dimensions

Size Code	Shaft Diameter	Part Number	B O.D.	J Outer Ring Width	L Snap Ring O.D.	C	D	G	K	M	N	R	T		Y	Approx. Weight
													Width	Tap		
204	1/2	ER8KCL◆●□△	1.8504	0.6240	2 1/16	3/32	1 15/64	0.4050	3/64	1 1/2	1.154	0.04	23/64	#10-32	0.142	0.62
	5/8	ER10KCL◆●□△														0.55
	3/4	ER12KCL◆●□△														0.54
	20.00	ER204KCL △	47.0000	15.8500	52.40	2.40	30.96	10.2900	1.20	38.10	29.310	1.00	8.70	M6X1	3.610	0.20
205	7/8	ER14KCL◆●□△	2.0472	0.7490	2 17/64	3/32	1 13/32	0.5080	3/64	1 5/8	1.313	0.04	23/64	1/4-28	0.185	0.65
	15/16	ER15KCL◆●□△														0.63
	1	ER16KCL◆●□△														0.61
	25.00	ER205KCL △	52.0000	19.0250	57.60	2.40	34.92	12.9000	1.20	41.40	33.350	1.00	8.70	M6X1	4.700	0.30
206	1 1/8	ER18KCL◆●□△	2.4409	0.8740	2 21/32	3/32	1 17/32	0.6250	3/64	2	1.587	0.04	7/16	1/4-28	0.224	0.96
	1 3/16	ER19KCL◆●□△														0.94
	1 1/4	ER20SKCL◆●□△														0.90
	1 1/4	ER20KCL◆●□△	2.8346	0.9365	3 5/64	1/8	1 47/64	0.6880	1/16	2 1/4	1.847	0.04	7/16	5/16-24	0.256	1.75
1 3/8	ER22KCL◆●□△	1.70														
1 7/16	ER23KCL◆●□△	1.62														
208	1 1/2	ER24KCL◆●□△	3.1496	1.0927	3 25/64	1/8	1 31/32	0.7500	1/16	2 9/16	2.083	0.06	7/16	5/16-24	0.297	2.18
	40.00	ER208KCL △	80.0000	27.7550	86.10	3.20	49.22	19.0500	1.60	65.00	52.910	1.60	11.10	M8X1.25	7.540	1.00
209	1 5/8	ER26KCL◆●□△	3.3465	1.0927	3 19/32	1/8	1 31/32	0.7500	1/16	2 3/4	2.281	0.06	7/16	5/16-24	0.297	2.28
	1 11/16	ER27KCL◆●□△														2.22
	1 3/4	ER28KCL◆●□△														2.15
210	1 7/8	ER30KCL◆●□△	3.5433	1.1240	3 25/32	1/8	2 5/64	0.7500	3/32	3	2.475	0.06	9/16	5/16-24	0.265	2.75
	1 15/16	ER31KCL◆●□△														2.61
211	2	ER32KCL◆●□△	3.9370	1.1860	4 11/64	1/8	2 15/64	0.8750	3/32	3 1/4	2.749	0.08	9/16	5/16-24	0.298	3.38
	2 3/16	ER35KCL◆●□△														3.07
212	2 1/4	ER36KCL◆●□△	4.3307	1.2490	4 9/16	1/8	2 19/32	1.0000	3/32	3 1/2	3.012	0.08	9/16	3/8-24	0.330	4.48
	2 3/8	ER38KCL◆●□△														4.38
	2 7/16	ER39KCL◆●□△														4.19
214	2 1/2	ER40KCL◆●□△	4.9213	1.3740	5 9/32	5/32	2 47/64	1.0620	7/64	3 15/16	3.433	0.08	3/4	3/8-24	0.374	5.92
	2 11/16	ER43KCL◆●□△														5.49
215	2 7/8	ER46KCL◆●□△	5.1181	1.4990	5 1/2	5/32	3	1.3130	7/64	4 3/8	3.632	0.08	3/4	3/8-24	0.374	6.60
	2 15/16	ER47KCL◆●□△														6.37
216	3	ER48KCL◆●□△	5.5118	1.6865	5 7/8	5/32	3 3/8	1.3130	7/64	5	3.920	0.12	3/4	3/8-24	0.406	8.05
	3 3/16	ER51KCL◆●□△														7.56

Additional Notes

Please call 1-866-REXNORD for availability
 Bearing O.D. tolerance for size code 204, +.0000 in/- .0005 in (+0.000 mm/-0.013 mm); for size code 205 thru 208, +.0000 in/- .0006 in (+0.000 mm/-0.015 mm); for size code 209 thru 212, +.0000 in/- .0008 in (+0.000 mm/-0.020 mm); for all other size codes, +.0000 in/- .0010 in (+0.000 mm/-0.025 mm)

Lip seals standard

- ◆ Available with E1 viton seals for all size codes

Available with free running style seals, add suffix ◆ FF, □ HFF or △ MHFF for all size codes

For the Selection Guide, Load Ratings and Speed Limits, see the Link-Belt 200 Series Ball Bearing Engineering section on pages 290 - 298.

Note: Dimensions subject to change. Certified dimensions of ordered material furnished on request.

ER-K

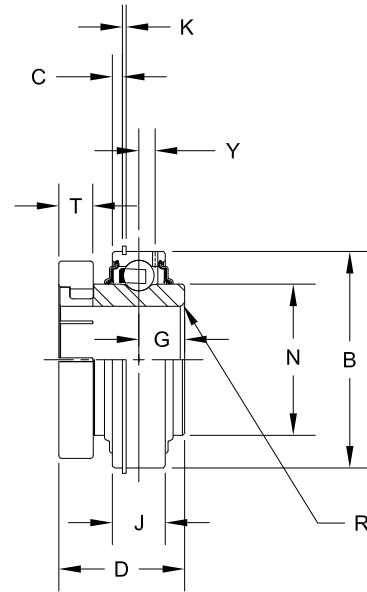
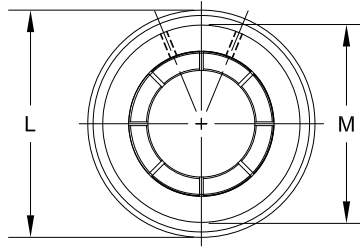
Interchange: GER, ER-T



Photo Shows an ER Adapter Series Ball Bearing Unit

Product Features

- Broad range of sealing options
- Spring locking setscrew mount
- Sealed & relubricatable
- Spherical O.D.
- See Features and Benefits for additional info on pages 286 - 287.



Bearing Dimensions

Size Code	Shaft Diameter	Part Number	B O.D.	J Outer Ring Width	L Snap Ring O.D.	C	D	G	K	M	N	R	T		Y	Approx. Weight
													Width	Tap		
204	1/2	ER8K♦♦ □Δ	1.8504	0.6240	2 1/16	3/32	1 15/64	0.4050	3/64	1 1/2	1.154	0.04	23/64	#10-32	0.142	0.62
	5/8	ER10K♦♦ □Δ														0.55
	3/4	ER12K♦♦ □Δ														0.54
	20.00	ER204K Δ	47.0000	15.8500	52.40	2.40	30.96	10.2900	1.20	38.10	29.310	1.00	8.70	M6X1	3.610	0.20
205	7/8	ER14K♦♦ □Δ	2.0472	0.7490	2 17/64	3/32	1 13/32	0.5080	3/64	1 5/8	1.313	0.04	23/64	1/4-28	0.185	0.65
	15/16	ER15K♦♦ □Δ														0.63
	1	ER16K♦♦ □Δ														0.61
	25.00	ER205K Δ	52.0000	19.0250	57.60	2.40	34.92	12.9000	1.20	41.40	33.350	1.00	8.70	M6X1	4.700	0.30
206	1 1/8	ER18K♦♦ □Δ	2.4409	0.8740	2 21/32	3/32	1 17/32	0.6250	3/64	2	1.587	0.04	7/16	1/4-28	0.224	0.96
	1 3/16	ER19K♦♦ □Δ														0.94
	1 1/4	ER20SK♦♦ □Δ														0.90
207	1 1/4	ER20K♦♦ □Δ	2.8346	0.9365	3 5/64	1/8	1 47/64	0.6880	1/16	2 1/4	1.847	0.04	7/16	5/16-24	0.256	1.75
	1 3/8	ER22K♦♦ □Δ														1.70
	1 7/16	ER23K♦♦ □Δ														1.62
208	1 1/2	ER24K♦♦ □Δ	3.1496	1.0927	3 25/64	1/8	1 31/32	0.7500	1/16	2 9/16	2.083	0.06	7/16	5/16-24	0.297	2.18
	40.00	ER208K Δ	80.0000	27.7550	86.10	3.20	49.22	19.0500	1.60	65.00	52.910	1.60	11.10	M8X1.25	7.540	1.00
209	1 5/8	ER26K♦♦ □Δ	3.3465	1.0927	3 19/32	1/8	1 31/32	0.7500	1/16	2 3/4	2.281	0.06	7/16	5/16-24	0.297	2.28
	1 11/16	ER27K♦♦ □Δ														2.22
	1 3/4	ER28K♦♦ □Δ														2.15
210	1 7/8	ER30K♦♦ □Δ	3.5433	1.1240	3 25/32	1/8	2 5/64	0.7500	3/32	3	2.475	0.06	9/16	5/16-24	0.265	2.75
	1 15/16	ER31K♦♦ □Δ														2.61
211	2	ER32K♦♦ □Δ	3.9370	1.1860	4 11/64	1/8	2 15/64	0.8750	3/32	3 1/4	2.749	0.08	9/16	5/16-24	0.298	3.38
	2 3/16	ER35K♦♦ □Δ														3.07
212	2 1/4	ER36K♦♦ □Δ	4.3307	1.2490	4 9/16	1/8	2 19/32	1.0000	3/32	3 1/2	3.012	0.08	9/16	3/8-24	0.330	4.48
	2 3/8	ER38K♦♦ □Δ														4.38
	2 7/16	ER39K♦♦ □Δ														4.19
214	2 1/2	ER40K♦♦ □Δ	4.9213	1.3740	5 9/32	5/32	2 47/64	1.0620	7/64	3 15/16	3.433	0.08	3/4	3/8-24	0.374	5.92
	2 11/16	ER43K♦♦ □Δ														5.49
215	2 7/8	ER46K♦♦ □Δ	5.1181	1.4990	5 1/2	5/32	3	1.3130	7/64	4 3/8	3.632	0.08	3/4	3/8-24	0.374	6.60
	2 15/16	ER47K♦♦ □Δ														6.37
216	3	ER48K♦♦ □Δ	5.5118	1.6865	5 7/8	5/32	3 3/8	1.3130	7/64	5	3.920	0.12	3/4	3/8-24	0.406	8.05
	3 3/16	ER51K♦♦ □Δ														7.56

Additional Notes

Please call 1-866-REXNORD for availability
 Bearing O.D. tolerance for size code 204, +.0000 in/-.0005 in (+0.000 mm/-0.013 mm); for size code 205 thru 208, +.0000 in/-.0006 in (+0.000 mm/-0.015 mm); for size code 209 thru 212, +.0000 in/-.0008 in (+0.000 mm/-0.020 mm); for all other size codes, +.0000 in/-.0010 in (+0.000 mm/-0.025 mm)

Lip seals standard

♦ Available with E1 viton seals for all size codes

Available with free running style seals, add suffix ♦ FF, □ HFF or Δ MHFF for all size codes

For the Selection Guide, Load Ratings and Speed Limits, see the Link-Belt 200 Series Ball Bearing Engineering section on pages 290 - 298.

Note: Dimensions subject to change. Certified dimensions of ordered material furnished on request.

ER

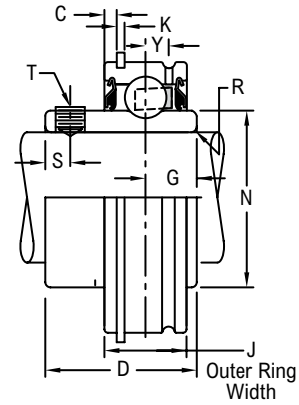
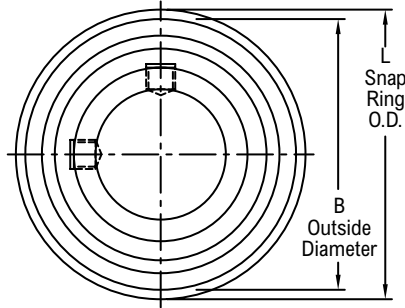
Interchange: SER, ER



Photo Shows an ER Adapter Series Ball Bearing Unit

Product Features

- Broad range of sealing options
- Spring locking setscrew mount
- Sealed & relubricatable
- Cylindrical O.D.
- O.D. mounted snap ring
- See Features and Benefits for additional info on pages 286 - 287.



Bearing Dimensions

Size Code	Shaft Diameter	Part Number	B O.D.	J Outer Ring Width	L Snap Ring O.D.	C	D	G	K	N	R	S	T Tap Size	Y	Approx. Weight
204	1/2	ER8♦ □Δ	1.8504	0.6240	2 1/16	3/32	1 7/32	0.4050	3/64	1.154	0.04	15/64	#10-32	0.142	0.62
	5/8	ER10♦ □Δ													0.55
	3/4	ER12♦ □Δ													0.54
205	7/8	ER14♦ □Δ	2.0472	0.7490	2 17/64	3/32	1 3/8	0.5080	3/64	1.313	0.04	15/64	1/4-28	0.185	0.65
	15/16	ER15♦ □Δ													0.63
	1	ER16♦ □Δ													0.61
	25.00	ER205 Δ	52.0000	19.0250	57.60	2.40	34.92	12.9000	1.20	33.350	1.00	2.00	M6X1	4.700	0.30
206	1 1/8	ER18♦ □Δ	2.4409	0.8740	2 21/32	3/32	1 1/2	0.6250	3/64	1.587	0.04	1/4	1/4-28	0.224	0.96
	1 3/16	ER19♦ □Δ													0.94
	1 1/4	ER20S♦ □Δ													0.90
	30.00	ER206 Δ	62.0000	22.2000	67.50	2.40	38.10	15.8800	1.20	40.310	1.00	6.40	M6X1	5.690	0.40
207	1 1/4	ER20♦ □Δ	2.8346	0.9365	3 5/64	1/8	1 11/16	0.6880	1/16	1.847	0.04	21/64	5/16-24	0.256	1.75
	1 3/8	ER22♦ □Δ													1.70
	1 7/16	ER23♦ □Δ													1.62
208	1 1/2	ER24♦ □Δ	3.1496	1.0927	3 25/64	1/8	1 15/16	0.7500	1/16	2.083	0.06	3/8	5/16-24	0.297	2.18
	40.00	ER208 Δ	80.0000	27.7550	86.10	3.20	49.22	19.0500	1.60	52.910	1.60	9.50	M8X1.25	7.540	1.00
209	1 5/8	ER26♦ □Δ	3.3465	1.0927	3 19/32	1/8	1 15/16	0.7500	1/16	2.281	0.06	3/8	5/16-24	0.297	2.28
	1 11/16	ER27♦ □Δ													2.22
	1 3/4	ER28♦ □Δ													2.15
210	1 7/8	ER30♦ □Δ	3.5433	1.1240	3 25/32	1/8	2 1/32	0.7500	3/32	2.475	0.06	3/8	3/8-24	0.265	2.75
	1 15/16	ER31♦ □Δ													2.61
211	2	ER32♦ □Δ	3.9370	1.1860	4 11/64	1/8	2 3/16	0.8750	3/32	2.749	0.08	3/8	3/8-24	0.298	3.38
	2 3/16	ER35♦ □Δ													3.07
212	2 1/4	ER36♦ □Δ	4.3307	1.2490	4 9/16	1/8	2 9/16	1.0000	3/32	3.012	0.08	3/8	3/8-24	0.330	4.48
	2 3/8	ER38♦ □Δ													4.38
	2 7/16	ER39♦ □Δ													4.19
214	2 1/2	ER40♦ □Δ	4.9213	1.3740	5 9/32	5/32	2 3/4	1.0620	7/64	3.433	0.08	3/8	3/8-24	0.374	5.92
	2 11/16	ER43♦ □Δ													5.49
215	2 7/8	ER46♦ □Δ	5.1181	1.4990	5 1/2	5/32	3 1/16	1.3130	7/64	3.632	0.08	3/8	3/8-24	0.374	6.60
	2 15/16	ER47♦ □Δ													6.37
216	3	ER48♦ □Δ	5.5118	1.6865	5 7/8	5/32	3 1/4	1.3130	7/64	3.920	0.12	3/8	3/8-24	0.406	8.05
	3 3/16	ER51♦ □Δ													7.56

Additional Notes

- Please call 1-866-REXNORD for availability
- Bearing O.D. tolerance for size code 204, +.0000 in/-.0005 in (+0.000 mm/-0.013 mm); for size code 205 thru 208, +.0000 in/-.0006 in (+0.000 mm/-0.015 mm); for size code 209 thru 212, +.0000 in/-.0008 in (+0.000 mm/-0.020 mm); for all other size codes, +.0000 in/-.0010 in (+0.000 mm/-0.025 mm)
- Lip seals standard
- ♦ Available with E1 viton seals

Available with free running style seals, add suffix ♦ FF, □ SFF or Δ MKFF
 For the Selection Guide, Load Ratings and Speed Limits, see the Link-Belt 200 Series Ball Bearing Engineering section on pages 290 - 298.
 Note: Dimensions subject to change. Certified dimensions of ordered material furnished on request.

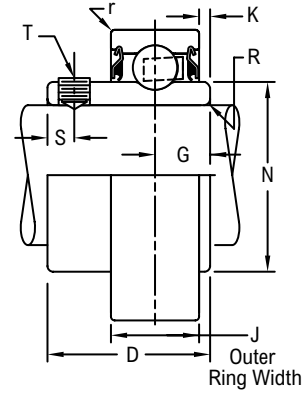
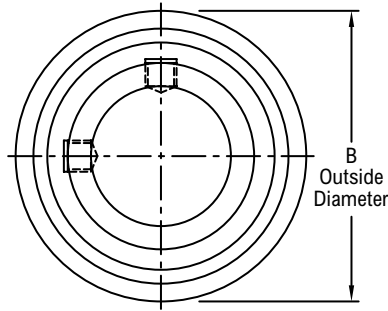
MSL



Photo Shows an Unmounted Ball Bearing Unit with Cylindrical Outside Diameter

Product Features

- Broad range of sealing options
- Wide inner ring for increased shaft stability
- Spring locking setscrew mount
- Sealed & non-relubricatable
- Cylindrical O.D.
- See Features and Benefits for additional info on pages 286 - 287.



Bearing Dimensions

Size Code	Shaft Diameter	Part Number	B O.D.	J Outer Ring Width	D	G	K	N	R	r	S	T	Approx. Weight
203	$\frac{1}{2}$	MSL8♦♦ □Δ	1.5748	0.5118	$\frac{31}{32}$	0.3910	$\frac{7}{64}$	0.941	0.024	0.024	$\frac{3}{16}$	#10-32	0.24
	$\frac{5}{8}$	MSL10♦♦ □Δ											
204	$\frac{3}{4}$	MSL12♦♦ □Δ	1.8504	0.5906	$1\frac{5}{32}$	0.4380	$\frac{9}{64}$	1.121	0.039	0.039	$\frac{3}{16}$	#10-32	0.35
205	1	MSL16♦♦ □Δ	2.0472	0.5906	$1\frac{7}{32}$	0.4520	$\frac{9}{64}$	1.313	0.039	0.039	$\frac{7}{32}$	1/4-28	0.39
207	$1\frac{1}{4}$	MSL20♦♦ □Δ	2.8346	0.7480	$1\frac{17}{32}$	0.5930	$\frac{7}{32}$	1.847	0.039	0.039	$\frac{1}{4}$	1/4-28	1.00
	$1\frac{3}{8}$	MSL22♦♦ □Δ											
	$1\frac{7}{16}$	MSL23♦♦ □Δ											

Additional Notes

- Please call 1-866-REXNORD for availability
- Bearing bore tolerance, +.0005 in/-.0000 in ($+0.013\text{ mm}/-0.000\text{ mm}$)
- Bearing O.D. tolerance for size code 203 thru 204, +.0000 in/-.0005 in ($+0.000\text{ mm}/-0.013\text{ mm}$); for all other size codes, +.0000 in/-.0006 in ($+0.000\text{ mm}/-0.015\text{ mm}$)
- Lip seals standard
- ♦ Available with E1 viton seals

- Available with free running style seals, add suffix ♦ FF, □ HFF or Δ MHFF
- For the Selection Guide, Load Ratings and Speed Limits, see the Link-Belt 200 Series Ball Bearing Engineering section on pages 290 - 298.
- Note: Dimensions subject to change. Certified dimensions of ordered material furnished on request.

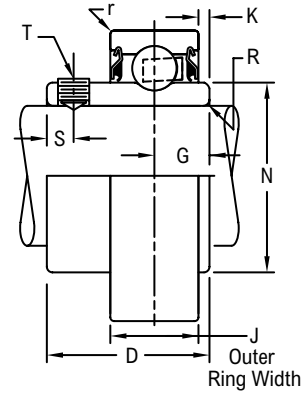
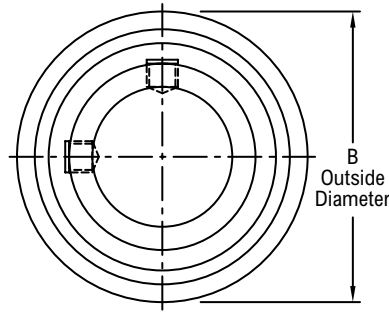
MSLN



Photo Shows an Unmounted Ball Bearing Unit with Cylindrical Outside Diameter

Product Features

- Broad range of sealing options
- Spring locking setscrew mount
- Sealed & non-relubricatable
- Cylindrical O.D.
- See Features and Benefits for additional info on pages 286 - 287.



Bearing Dimensions

Size Code	Shaft Diameter	Part Number	B O.D.	J Outer Ring Width	D	G	K	N	R	r	S	T	Approx. Weight
203	1/2	MSLN8♦●□△	1.5748	0.5118	51/64	0.2770	0	0.941	0.024	0.024	3/16	#10-32	0.22
	5/8	MSLN10♦●□△											
204	3/4	MSLN12♦●□△	1.8504	0.5906	15/16	0.2940	0	1.121	0.039	0.039	3/16	#10-32	0.32
205	1	MSLN16♦●□△	2.0472	0.5906	15/16	0.3090	0	1.313	0.039	0.039	7/32	1/4-28	0.34

Additional Notes

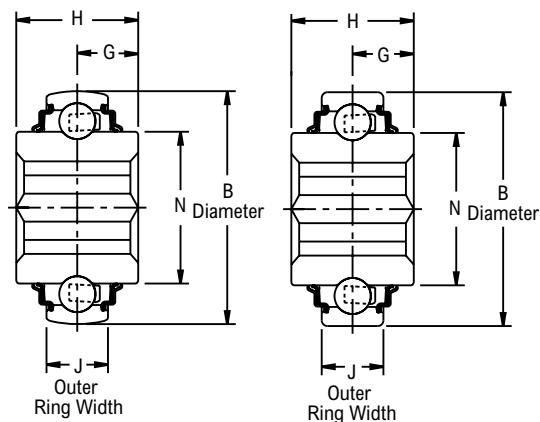
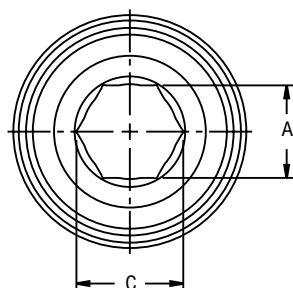
- Please call 1-866-REXNORD for availability
- Bearing bore tolerance, +.0005 in/-.0000 in (*+0.013 mm/-0.000 mm*)
- Bearing O.D. tolerance for size code 203 thru 204, +.0000 in/-.0005 in (*+0.000 mm/-0.013 mm*); for all other size codes, +.0000 in/-.0006 in (*+0.000 mm/-0.015 mm*)
- Lip seals standard
- ♦ Available with E1 viton seals

- Available with free running style seals, add suffix ● FF, □ HFF or △ MHFF
- For the Selection Guide, Load Ratings and Speed Limits, see the Link-Belt 200 Series Ball Bearing Engineering section on pages 290 - 298.
- Note: Dimensions subject to change. Certified dimensions of ordered material furnished on request.

Hex



Photo Shows an Unmounted Hex Bore Ball Bearing Unit



Spherical

Cylindrical

Product Features

Spherical or Cylindrical O.D.
Sealed & non-relubricatable
See Features and Benefits for additional info on pages 286 - 287.

Bearing Dimensions

Size Code	Shaft Diameter	Part Number	Industry Number	B O.D.	J Outer Ring Width	A	C	G	H	N	Approx. Weight
Cylindrical											
204	$\frac{5}{8}$	10KB204N*	204KRR4	1.8504	0.5512	0.626	0.728	0.412	0.8250	1.121	0.30
	$\frac{11}{16}$	11KB204N*	204KRR2			0.695	0.797				
205	$\frac{7}{8}$	14KB205N*Δ	205KRR2	2.0472	0.5906	0.876	1.010	0.500	1.0000	1.313	0.40
206	1	16KB206N*	206KRR6	2.4409	0.6299	1.001	1.153	0.472	0.9449	1.587	0.60
207	$1\frac{1}{8}$	18KB207N*Δ	207KRR9	2.8346	0.6693	1.126	1.299	0.742	1.4844	1.847	1.10
209	$1\frac{1}{2}$	24KB209N*Δ	209KRR2	3.3465	0.7480	1.501	1.732	0.591	1.1811	2.281	1.40
210	$1\frac{5}{8}$	26KB3210E3 Δ	W210PP7	3.5433	1.1875	1.626	1.876	0.594	1.1875	2.475	1.60
Spherical											
204	$\frac{11}{16}$	11K204N*	204KRRB2	1.8504	0.5906	0.695	0.797	0.412	0.8250	1.121	0.30
205	$\frac{7}{8}$	14K205N*Δ	205KRRB2	2.0472	0.5906	0.876	1.010	0.500	1.0000	1.313	0.40
206	1	16K206N*	206KRRB6	2.4409	0.7087	1.001	1.153	0.472	0.9449	1.587	0.60
207	$1\frac{1}{8}$	18K207N*Δ	207KRRB9	2.8346	0.7480	1.126	1.299	0.742	1.4844	1.847	1.10
208	$1\frac{1}{4}$	20K5208E3 Δ	W208PPB16	3.1496	0.7087	1.251	1.450	0.718	1.4375	2.083	1.20
209	$1\frac{1}{2}$	24K209N*Δ	209KRRB2	3.3465	0.8661	1.501	1.732	0.591	1.1811	2.281	1.40
210	$1\frac{5}{8}$	26K3210E3 Δ	W210PPB7	3.5433	1.1875	1.626	1.876	0.594	1.1875	2.475	1.60

Additional Notes

Please call 1-866-REXNORD for availability
Δ E3 triple lip seals are standard for size codes 208 & 210
On size codes 205, 207 & 209, Δ available with E3 triple lip seals
For the Selection Guide, Load Ratings and Speed Limits, see the Link-Belt 200 Series Ball Bearing Engineering section on pages 290 - 298.

Note: Dimensions subject to change. Certified dimensions of ordered material furnished on request.

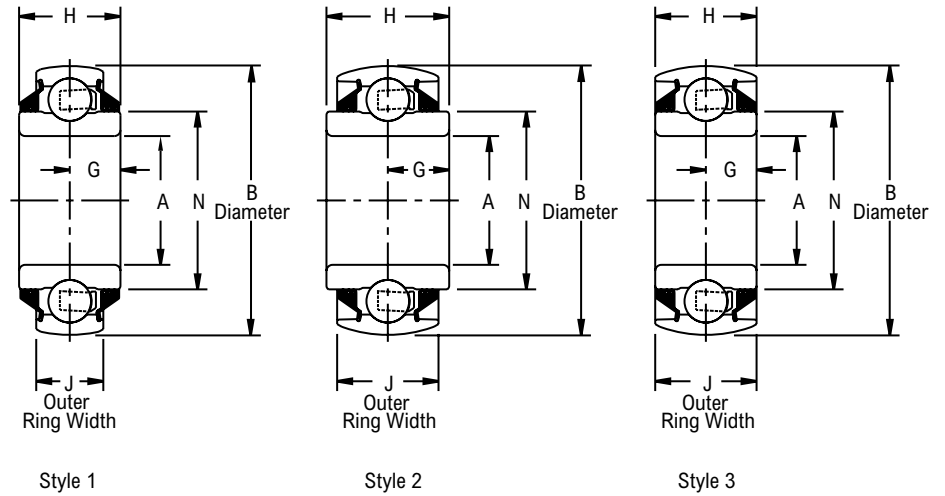
Round



Photo Shows an Unmounted Round Bore Ball Bearing Unit

Product Features

- Spherical or Cylindrical O.D.
- Triple lip seals
- Optional relubrication feature
- See Features and Benefits for additional info on pages 286 - 287.

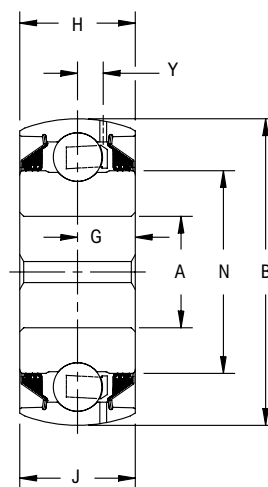


*Note: Drawing represents spherical O.D. bearing

Bearing Dimensions

Size Code	Shaft Diameter	Part Number	Industry Number	Style	B O.D.	J Outer Ring Width	A	G	H	N	Y	Approx. Weight
Non-relubricatable												
Cylindrical												
208	1 3/16	19RB208E3 Δ	W208PP7	1	3.1496	0.7087	1.1880	0.594	1.1875	2.083	-	1.30
		19RB3208E3 Δ	W208PP4	3		1.1875						
	1 1/2	24RB6208E3 Δ	W208PP2	2		0.8268	1.5005	0.844	1.6875			1.50
		24RB8208E3 Δ	W208PP10	1								
210	1 15/16	31RB3210E3 Δ	W210PP2	3	3.5433	1.1875	1.9380	0.594	1.1875	2.475	-	1.50
211	2 3/16	35RB3211E3 Δ	W211PP2	3	3.9370	1.3125	2.1880	0.656	1.3125	2.749	-	2.25
Spherical												
208	7/8	14R4208E3 Δ	W208PPB14	2	3.4380	1.1875	0.8900	0.719	1.4375	2.083	-	1.30
		19R208E3 Δ	W208PPB7	1		0.7087						
	1 3/16	19R3208E3 Δ	W208PPB4	3		1.1875	1.5005	0.844	1.6875			1.50
		24R6208E3 Δ	W208PPB2	2								
209	1 1/2	24R3209E3 Δ	W209PPB4	3	3.3465	1.1875	1.5350	0.594	1.1875	2.281	-	1.50
		24R4209E3 Δ	W209PPB6	2	3.4380			0.719	1.4375			
	45.00	R3209E3 Δ	W209PPB2	3	85.0000	30.1620	45.0000	15.080	30.1620			57.940
210	1 3/4	28R3210E3 Δ	W210PPB5	3	3.5433	1.1875	1.7850	0.594	1.1875	2.475	-	1.60
	1 15/16	31R3210E3 Δ	W210PPB2				1.9380					1.50
211	2 3/16	35R3211E3 Δ	W211PPB2	3	3.9370	1.3125	2.1880	0.656	1.3125	2.749	-	2.25

Continued...



*Note: Drawing represents spherical O.D. bearing

Continued...

Bearing Dimensions

Size Code	Shaft Diameter	Part Number	Industry Number	Style	B O.D.	J Outer Ring Width	A	G	H	N	Y	Approx. Weight
Relubricatable												
Cylindrical												
210	1 3/8	22RBG3210E3 Δ	GW210PP3	3	3.5433	1.1875	1.4065	0.594	1.1875	2.475	0.255	1.40
	1 15/16	31RBG3210E3 Δ	GW210PP2				1.9380					1.50
211	1 5/8	26RBG3211E3 Δ	GW211PP4	3	3.9370	1.3125	1.6600	0.656	1.3125	2.749	0.267	1.60
	2 3/16	35RBG3211E3 Δ	GW211PP2				2.1880					2.25
Spherical												
209	1 1/2	24RG3209E3 Δ	GW209PPB4	3	3.3465	1.1875	1.5350	0.594	1.1875	2.281	0.248	1.50
	45.00	RG3209E3 Δ	GW209PPB2		85.0000	30.1620	45.0000	15.080	30.1620	57.940	6.300	0.60
210	1 3/8	22RG3210E3 Δ	GW210PPB3	3	3.5433	1.1875	1.4065	0.594	1.1875	2.475	0.255	1.40
	1 3/4	28RG3210E3 Δ	GW210PPB5				1.7850					1.60
	1 15/16	31RG3210E3 Δ	GW210PPB2				1.9380					1.50
211	1 5/8	26RG3211E3 Δ	GW211PPB4	3	3.9370	1.3125	1.6600	0.656	1.3125	2.749	0.267	1.60
	2 3/16	35RG3211E3 Δ	GW211PPB2				2.1880					2.25

Additional Notes

Please call 1-866-REXNORD for availability
 Unground spherical O.D. tolerance, +/- .005 in (+/- 0.13 mm).
 Center portion of O.D. is cylindrical
 Δ E3 triple lip seals standard

For the Selection Guide, Load Ratings and Speed Limits, see the Link-Belt 200 Series Ball Bearing Engineering section on pages 290 - 298.

Note: Dimensions subject to change. Certified dimensions of ordered material furnished on request.

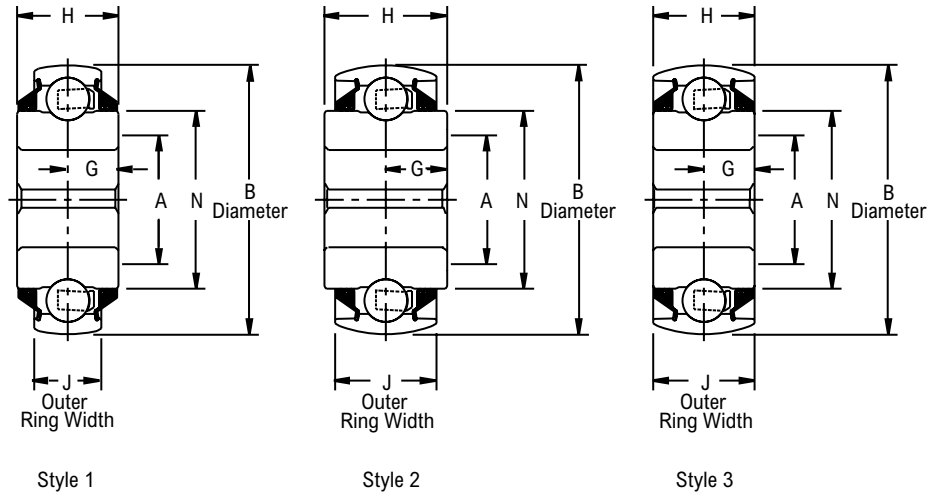
Square



Photo Shows an Unmounted Square Bore Ball Bearing Unit

Product Features

- Spherical or Cylindrical O.D.
- Triple lip seals
- Optional relubrication feature
- See Features and Benefits for additional info on pages 286 - 287.

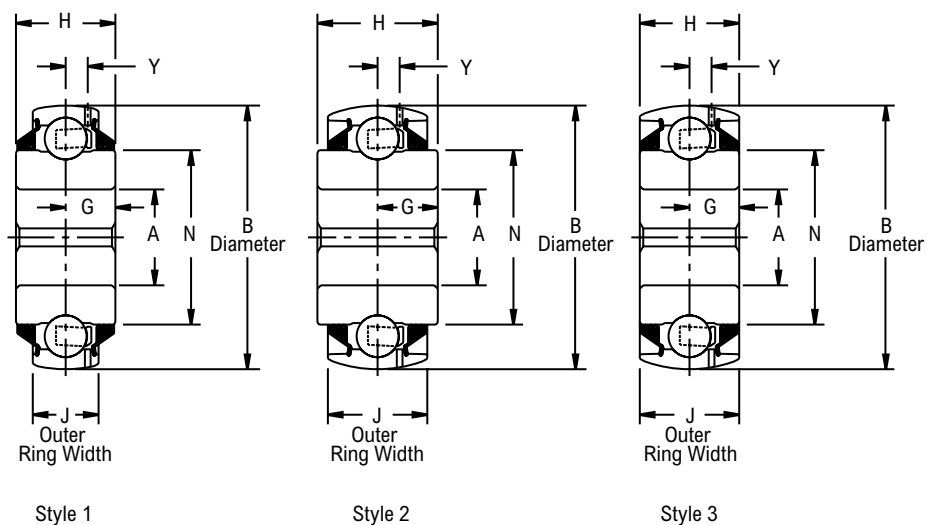


*Note: Drawing represents spherical O.D. bearing

Bearing Dimensions

Size Code	Shaft Diameter	Part Number	Industry Number	Style	B O.D.	J Outer Ring Width	A	G	H	N	Y	Approx. Weight	
Non-relubricatable													
Cylindrical													
208	7/8	14SB5208E3 Δ	W208PP13	1	3.1496	0.7087	0.9050	0.719	1.4375	2.083	-	1.50	
	1	16SB2208E3 Δ	W208PP9	2		1.1875						1.0300	1.70
		16SB5208E3 Δ	W208PP6	1		0.7087	1.1850					1.50	
	1 1/8	18SB22E08E3 Δ	W208PP8	2		1.1875						0.7087	1.50
		18SB52E08E3 Δ	W208PP5	1		0.7087							2.40
211	1 1/2	24SB3211E3 Δ	W211PP3	3	3.9370	1.3125	1.5300	0.656	1.3125	2.749	-	2.40	
Spherical													
208	7/8	14S4208E3 Δ	W208PPB11	2	3.4380	1.1875	0.9050	0.719	1.4375	2.083	-	1.50	
	1	16S2208E3 Δ	W208PPB9		3.1496	0.7087	1.0300					1.70	
		16S5208E3 Δ	W208PPB6	1		3.4380	1.1875					1.1850	1.50
	1 1/8	18S22E08E3 Δ	W208PPB8	2	0.7087		1.1850						
		18S42E08E3 Δ	W208PPB12	1								3.1496	0.7087
209	1 1/4	20S2209E3 Δ	W209PPB5	2	3.3465	1.1875	1.2800	0.719	1.4375	2.281	-	1.85	
		20S4209E3 Δ	W209PPB7		3.4380	1.1875	1.2800	0.719	1.4375	2.281	-	1.85	
211	1 1/2	24S3211E3 Δ	W211PPB3	3	3.9370	1.3125	1.5300	0.656	1.3125	2.749	-	2.40	

Continued...



*Note: Drawing represents spherical O.D. bearing

Continued...

Bearing Dimensions

Size Code	Shaft Diameter	Part Number	Industry Number	Style	B O.D.	J Outer Ring Width	A	G	H	N	Y	Approx. Weight
Relubricatable												
Cylindrical												
209	1 1/4	20SBG5209E3 Δ	GW209PP8	1	3.3465	0.8661	1.2800	0.719	1.4375	2.281	0.254	1.85
211	1 1/2	24SBG3211E3 Δ	GW211PP3	3	3.9370	1.3125	1.5300	0.656	1.3125	2.749	0.267	2.40
Spherical												
208	1	16SG5208E3 Δ	GW208PPB6	1	3.1496	0.8661	1.0300	0.719	1.4375	2.083	0.253	1.70
	1 1/8	18SG22E08E3 Δ	GW208PPB8	2		1.1875						1.50
		18SG52E08E3 Δ	GW208PPB5	1		0.8661						1.1850
209	1 1/4	20SG5209E3 Δ	GW209PPB8	1	3.3465	0.8661	1.2800	0.719	1.4375	2.281	0.254	1.85
211	1 1/2	24SG3211E3 Δ	GW211PPB3	3	3.9370	1.3125	1.5300	0.656	1.3125	2.749	0.267	2.40

Additional Notes

Please call 1-866-REXNORD for availability
 Unground spherical O.D. tolerance, +/- .005 in (+/- 0.13 mm).
 Center portion of O.D. is cylindrical
 Δ E3 triple lip seals standard
 For the Selection Guide, Load Ratings and Speed Limits, see the Link-Belt 200 Series Ball Bearing Engineering section on pages 290 - 298.

Note: Dimensions subject to change. Certified dimensions of ordered material furnished on request.

Ball Bearings Medium Duty (200 Series) Units: Link-Belt



Contents

	Page
Features and Benefits	400
Nomenclature	402
Engineering	404
Dimensions	
Pillow Blocks	409
Flange Blocks	411
Take-up Blocks	417
Hanger Units	419
Unmounted Replacement Bearings	421

Industries Served

Aggregates
Agriculture
Air Handling
Package Handling
Construction
Shipping
Mining
Forest Products



Medium Duty Ball Bearings Designed for Long Life and Precision Performance

200 Series Medium Duty Ball Bearings provide design and performance features developed by decades of experience in supplying precision ball bearing inserts for other major mounted bearing manufacturers and complete mounted units to machinery and equipment manufacturers. They are priced competitively to bearings of comparable construction and design. In addition to sound basic design and construction, special features minimize the three most common

causes of premature bearing failure... loosening of bearings on rotating shafts, entrance of contaminants or loss of lubricant due to seal failure and insufficient housing strength. Medium duty foot-mounted pillow blocks, flange units, take-up blocks and hanger bearings cataloged in the following pages are available from stock. For other sizes, mountings or special requirements to fit your applications, please consult the Rexnord Bearing Products.



Spring Locking

Precision alignable ball bearing of deep groove construction for high capacity and high precision applications. Spring locking collars of setscrew locking security, locks bearing to the shaft.

Centrik-Lok CL Shaft Locking Device

The Centrik-Lok method of fastening the bearing inner race to the shaft provides substantial improvement in holding power compared to spring locking collars. The unique 2-piece collar and 8-tab design offers the best shaft holding force in the industry.

Combination Seal-Flinger System

Optimum protection from loss of lubricant and entrance of dirt and contaminants is achieved with positive lip-type contact seals. The resulting longer seal life extends bearing life significantly.

Rugged, One-Piece Cast Iron Housing

Housings are designed to withstand bearing load ratings, external vibration and shock. Foot mounted pillow block bolt holes are elongated for easy installation and adjustment.

Spherically-Seated Bearing Insert with Anti-Rotation Device

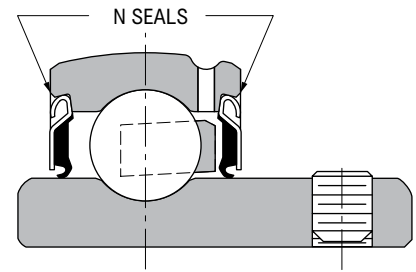
The spherical fit between the outer race O.D. and I.D. of the block is precisely controlled for easy shaft alignment. The anti-rotation device is permanently installed in the bearing insert O.D. It engages one of the housing insertion slots, preventing outer race creep and wear of housing. There is no danger of losing a separable pin during field replacement of bearings and no danger of preloading the bearing as is possible in other designs where a lube fitting is tightened against a locking pin.

Precision Mounted Ball Bearings with Shaft Locking Device

Centrik-Lok precision mounted ball bearings feature a concentric shaft locking device, resulting in a great improvement in the holding power (locking efficiency). Field experience shows substantial improvement in holding power when compared to eccentric locking collars and even greater improvement in locking efficiency when compared to 120° setscrew positioning and other types of locking arrangements.

Standard sealing arrangements

Standard steel clad Type N single lip seals have a useful temperature range of -40°F to $+225^{\circ}\text{F}$ and can withstand temperatures of 250°F for intermittent service. Special sealing arrangements are available for higher temperatures and “free-running” or special contamination resistance.



STANDARD MEDIUM DUTY SEAL

Special optional sealing arrangements

Suffix-MHFF indicates flingers both sides. This provides a sealed, “free-running” bearing with heat shield protection. It is satisfactory for temperatures from -40°F to $+225^{\circ}\text{F}$. Rexnord Bearing Products must be consulted regarding availability of any of these optional sealing configurations.

Examples for ordering:

1. Mounted Unit MPS219MHFF
2. Bearing Insert MSG219MHFFLPA

High temperature ball bearing inserts and housed units

Mounted ball bearings and inserts are available for high temperature applications up to 400°F . The “E1” package provides the following features.

1. Extra Internal Diameters Clearance (DC), based on a 200°F temperature differential between inner and outer races, compensates for the inner race expanding at a faster rate than the outer race and will avoid preloading of the bearings.
2. Steel Retainer (Cage) – 2 piece riveted construction.
3. High Temperature Lubrication – prelubricated with a No.2 consistency bentone-base grease with petroleum oil. When operated near upper limit, (400°F to 450°F) daily relubrication is required.
4. Viton Seals withstand temperatures to 400°F .

Examples for ordering:

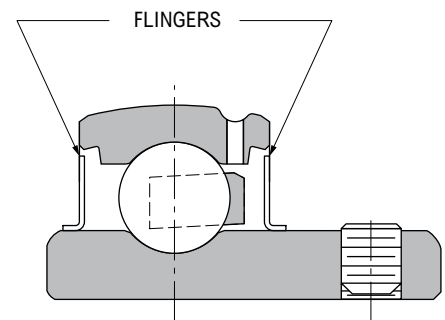
1. Mounted Unit MPS219E1
2. Bearing Insert MSG219E1LPA

Free running applications and applications above 400°F

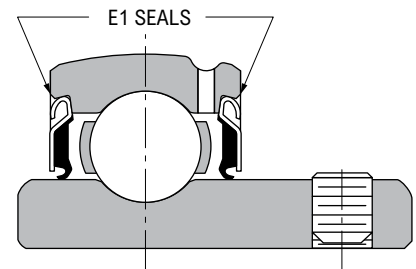
Sealing options such as -FF (flingers only) for “free running” applications and/or temperatures over 400°F where contamination is not severe. The flinger acts as a labyrinth seal. High temperature bearings require a greater amount of diametral clearance (DC) and a higher temperature lubricant. Consult Rexnord Bearing Products for recommendations.

Examples for ordering:

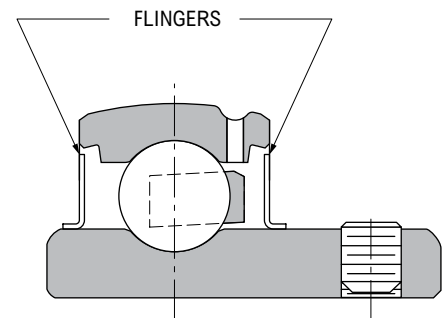
1. Mounted Unit MPS219FF
2. Bearing Insert MSG219FFLPA



-MHFF



-E1



-FF

200 Series Medium Duty Ball Bearing Nomenclature

Symbol	Description	M	P	CL	2	19	N	K 75
M	Medium Duty	_____						
F	Flanged 4-bolt		_____					
FC	Flanged cartridge unit, 4-bolt round		_____					
FX	Flanged unit, 2-bolt		_____					
P	Pillow block, standard backing		_____					
PL	Pillow block, low backing		_____					
TH	Take-up, wide slot		_____					
CHB	Hanger screw conveyor unit		_____					
EHB	Hanger unit		_____					
CL	Narrow inner ring, Centrik-Lok collar			_____				
S	Narrow inner ring, Spring Locking			_____				
2	200 Series ball bearing designation				_____			
19	Shaft size in sixteenths of an inch					_____		
M30	Shaft size, metric series in millimeters					_____		
J	Steel retainers						_____	
E1	Viton seals, Increased Clearance, Steel Retainer, High Temp. Lube						_____	
E	Molded single lip seals						_____	
FF	Flingers only, 50% grease fill						_____	
HFF	Flingers only, 10% oil fill						_____	
MHFF	Flingers only, 10% grease fill						_____	
N	Single lip seals - standard						_____	
K75	Nickel plated housing							_____
K4	100% grease filled							_____
K5	No grease - Preservative only							_____
K6	100% grease filled and housing plugged							_____
18A	SHC100 grease							
18W	SHC460 grease							
18Y	SHC220 grease							
4C	Molykote 44 grease							
99A	Food grade grease							
2, 3, 4, 5	Clearances other than standard							

200 Series Medium Duty Ball Bearing Insert Nomenclature

Symbol	Description	M	S	G	2	20	N	L	PA
M	Medium Duty	_____							
CL	Narrow inner ring, Centrik-Lok collar		_____						
S	Narrow inner ring, Spring Locking			_____					
None	Non-relubricatable bearing				_____				
G	Relubricatable bearing					_____			
2	200 Series ball bearing designation						_____		
20	Shaft size in sixteenths of an inch							_____	
M30	Shaft size, metric series in millimeters								_____
E1	Viton seals, Increased Clearance, Steel Retainer, High Temp. Lube								_____
E	Molded single lip seals								
FF	Flingers only, 50% grease fill								
HFF	Flingers only, 10% oil fill								
MHFF	Flingers only, 10% grease fill								
N	Single lip seals - standard								
L1	Bearing without collar								
L	Bearing with collar & setscrews								
PA	Suffix designation for unmounted replacement bearing insert								

200 Series Medium Duty Ball Bearings Selection Guide

To select a bearing, determine the applied radial load, the applied thrust load, the desired Rating Life, and applicable operating conditions. The procedure shown here will aid in selecting a bearing to meet an L₁₀ design life. The formulas for calculating life expectancy should be used to determine the Rating Life L₁₀ for the bearing selected.

The selection procedures and rating formulas shown here are in agreement with The American Bearing Manufacturers Association Standards and ANSI/ABMA Standards STD 9-1990. Ratings are based on fatigue life. The Rating Life or fatigue life at 90% reliability is the usual basis for bearing selection.

Medium duty bearings have extended inner rings on one side only for compactness and low cost. These series are applicable to light or moderate duty requirements.

Where non-relubricatable bearings are used, bearing life is often limited by grease life, which is in turn affected by operating conditions. Also, economically designed housings must be applied within proportionate load limits. To assure a satisfactory bearing application, fitting practice, mounting, lubrication, sealing, static rating, housing strength, operating conditions and maintenance must be considered.

Steps for Selection

Step 1

Determine an appropriate L₁₀ design life.

Type of service	Operating time, hours per year	Design life, years	L ₁₀ design life, hours
Light seasonal usage	500 to 750	3-5	3,000
Heavy seasonal usage	1,400 to 1,600	4-6	8,000
Industrial—8 hour shift	2,000	10	20,000

Step 2

Determine a required $\left(\frac{C}{P}\right)$ from Table 1.

Step 3

Calculate the required C and select a ball bearing.

a For radial load only:

$$P = F_r$$

$$\text{required } C = \left(\frac{C}{P}\right) P \text{ using } \left(\frac{C}{P}\right) \text{ from Step 2}$$

Select a ball bearing from Table 3 with a basic load rating C equal to or greater than the required C.

b For combined radial and thrust loads when $\frac{F_a}{F_r}$ is 0.19 or less:

$$P = F_r$$

$$\text{required } C = \left(\frac{C}{P}\right) P \text{ using } \left(\frac{C}{P}\right) \text{ from Step 2}$$

Select a ball bearing from Table 3 with a basic load rating C equal to or greater than the required C.

Step 3 (continued)

c For combined radial and thrust loads when $\frac{F_a}{F_r}$ is greater than 0.19, use the following trial method:

$$\text{Maximum } P = .56F_r + 2.30F_a$$

$$\text{Maximum required } C = \left(\frac{C}{P}\right) P \text{ using } \left(\frac{C}{P}\right) \text{ from Step 2}$$

Select a trial ball bearing with a basic load rating C from Table 3 approximately equal to the maximum required C.

With this trial bearing calculate: $\frac{F_a}{Nd^2}$

Determine X and Y from Table 2.

Calculate P for the trial bearing.

$$P = XF_r + YF_a$$

$$\text{required } C = \left(\frac{C}{P}\right) P \text{ for the trial bearing using } \left(\frac{C}{P}\right) \text{ from Step 2}$$

Consult Table 3, basic load rating. If a smaller bearing meets or nearly meets the required C, its life expectancy can be calculated.

Note: If the load P is greater than .15C for series 25 and 35 consult Rexnord Bearing Products.

Selection

Symbols for formulas:

C = basic load rating, pounds (or newtons)	n = speed, revolutions per minute
C ₀ = static load rating, pounds (or newtons)	P = equivalent radial load, pounds (or newtons)
e = a reference value	X = radial factor
F _a = thrust load, pounds (or newtons)	Y = thrust factor
F _r = radial load, pounds (or newtons)	
L ₁₀ = rating life, hours	

Table 1 • Relation of L₁₀ life and speed to $\left(\frac{C}{P}\right)$

Bearing life, hours L ₁₀	$\left(\frac{C}{P}\right)$ ratio								
	Speed, n								
	50	100	200	300	400	500	600	700	800
3000	2.08	2.62	3.30	3.77	4.15	4.47	4.75	5.01	5.23
4000	2.29	2.88	3.63	4.15	4.57	4.92	5.23	5.51	5.76
5000	2.46	3.10	3.91	4.47	4.92	5.30	5.64	5.93	6.20
6000	2.62	3.30	4.15	4.75	5.23	5.64	5.99	6.30	6.59
8000	2.88	3.63	4.57	5.23	5.76	6.20	6.59	6.94	7.25
10000	3.10	3.91	4.92	5.64	6.20	6.68	7.10	7.47	7.81
12000	3.30	4.15	5.23	5.99	6.59	7.10	7.54	7.94	8.30
14000	3.47	4.37	5.51	6.30	6.94	7.47	7.94	8.36	8.74
16000	3.63	4.57	5.76	6.59	7.25	7.81	8.30	8.74	9.14
18000	3.77	4.75	5.99	6.86	7.54	8.13	8.63	9.09	9.50
20000	3.91	4.92	6.20	7.10	7.81	8.42	8.94	9.41	9.84
25000	4.21	5.30	6.68	7.65	8.42	9.07	9.63	10.10	10.60
30000	4.47	5.64	7.10	8.13	8.94	9.63	10.20	10.80	11.30
35000	4.71	5.93	7.47	8.55	9.41	10.10	10.80	11.30	11.90
40000	4.92	6.20	7.81	8.94	9.84	10.60	11.30	11.90	12.40
45000	5.12	6.45	8.13	9.30	10.20	11.00	11.70	12.30	12.90
50000	5.30	6.68	8.42	9.63	10.60	11.40	12.10	12.80	13.40
60000	5.64	7.10	8.94	10.20	11.30	12.10	12.90	13.60	14.20
70000	5.93	7.47	9.41	10.80	11.90	12.80	13.60	14.30	14.90
80000	6.20	7.81	9.84	11.30	12.40	13.40	14.20	14.90	15.60
90000	6.45	8.13	10.20	11.70	12.90	13.90	14.80	15.50	16.20
100000	6.68	8.42	10.60	12.10	13.40	14.40	15.30	16.10	16.80
150000	7.65	9.63	12.10	13.90	15.30	16.50	17.50	18.40	19.30
200000	8.42	10.60	13.40	15.30	16.80	18.10	19.30	20.30	21.20
	Speed, n								
	900	1000	1200	1500	1800	2400	3600	6000	10000
3000	5.44	5.64	5.99	6.45	6.86	7.54	8.63	10.20	12.10
4000	5.99	6.20	6.59	7.10	7.54	8.30	9.50	11.30	13.40
5000	6.45	6.68	7.10	7.65	8.13	8.94	10.20	12.10	14.40
6000	6.86	7.10	7.54	8.13	8.63	9.50	10.90	12.90	15.30
8000	7.54	7.81	8.30	8.94	9.50	10.50	12.00	14.20	16.80
10000	8.13	8.42	8.94	9.63	10.20	11.30	12.90	15.30	18.10
12000	8.63	8.94	9.50	10.20	10.90	12.00	13.70	16.20	19.30
14000	9.09	9.41	10.0	10.80	11.40	12.60	14.40	17.10	20.30
16000	9.50	9.84	10.5	11.30	12.00	13.20	15.10	17.90	21.20
18000	9.88	10.20	10.90	11.70	12.40	13.70	15.70	18.60	22.00
20000	10.20	10.60	11.30	12.10	12.90	14.20	16.20	19.30	22.80
25000	11.00	11.40	12.10	13.10	13.90	15.30	17.50	20.70	24.60
30000	11.70	12.10	12.90	13.90	14.80	16.20	18.60	22.00	26.10
35000	12.30	12.80	13.60	14.60	15.50	17.10	19.60	23.20	27.50
40000	12.90	13.40	14.20	15.30	16.20	17.90	20.50	24.30	28.70
45000	13.40	13.90	14.80	15.90	16.90	18.60	21.30	25.20	29.90
50000	13.90	14.40	15.30	16.50	17.50	19.30	22.00	26.10	31.00
60000	14.80	15.30	16.20	17.50	18.60	20.50	23.40	27.80	32.90
70000	15.50	16.10	17.10	18.40	19.60	21.50	24.60	29.20	34.60
80000	16.20	16.80	17.90	19.30	20.50	22.50	25.80	30.50	36.20
90000	16.90	17.50	18.60	20.00	21.30	23.40	26.80	31.80	37.70
100000	17.50	18.10	19.30	20.70	22.00	24.30	27.80	32.90	39.00
150000	20.00	20.70	22.00	23.70	25.20	27.80	31.80	37.70	44.60
200000	22.00	22.80	24.30	26.10	27.80	30.50	35.00	41.40	49.10

Basic formula

$$\left(\frac{C}{P}\right) = \left(\frac{L_{10} \times n \times 60}{1,000,000}\right)^{1/3}$$

$$L_{10} = \frac{\left(\frac{C}{P}\right)^3 \times 1,000,000}{n \times 60}$$

Life Expectancy

To calculate the Rating Life L₁₀ of any selected or trial bearing:

Step 1

Determine the equivalent radial load P.

a For radial load only:
P = F_r

b For combined radial and thrust load:
P = X F_r + Y F_a using X and Y from Table 2 below.

Step 2

Calculate the ratio of basic load rating C to the equivalent radial load.

$$\left(\frac{C}{P}\right)$$

Step 3

Approximate the bearing life from Table 1.

Table 2 • X and Y factors for ball bearings

F _a Nd ²	e	F _a /F _r ≤ e		F _a /F _r > e	
		X	Y	X	Y
25	.19	1.0	0	.56	2.30
37.5	.21	1.0	0	.56	2.15
50	.22	1.0	0	.56	1.99
75	.24	1.0	0	.56	1.85
100	.26	1.0	0	.56	1.71
125	.27	1.0	0	.56	1.63
150	.28	1.0	0	.56	1.56
200	.30	1.0	0	.56	1.45
300	.34	1.0	0	.56	1.31
500	.38	1.0	0	.56	1.15
750	.42	1.0	0	.56	1.04
1000	.44	1.0	0	.56	1.00

For values between those in the table linear interpolation can be used.

Life Adjustment

The Rating Life, L₁₀, may be modified for some applications in accordance with the formula

$$L'n = a_1 a_2 a_3 L_{10}$$

where L'n = Adjusted life for (100-n) % reliability,

a₁ = Life adjustment factor for reliability

a₂ = Life adjustment factor for material and processing

a₃ = Life adjustment factor for operating conditions.

For most normal applications, all factors will be taken as 1, and the Rating Life used as the selection basis or life estimate. In addition, as long as standard catalog bearings are used, a₂ will be normally set equal to one. The factor a₃ covers such things as lubrication, misalignment, and temperature. Some conditions that could yield a₃ significantly different than unity include speeds less than 20000 DN or greater than 200000 DN, temperatures below -40°F (-40°C) or above 275°F (135°C). For other possible conditions, as well as additional information on life adjustment factors, consult Rexnord Bearing Products.

Table 3 - Load Ratings

Size Code	C Basic load rating		Co Static load rating		Approximate speed limit RPM*			d Ball Diameter	N Number of balls	Nd ²
	Pounds	Newtons	Pounds	Newtons	N Seals	E Seals‡	Flingers	inches		
206	4390	19500	2530	1130	8000	5600	9800	3/8	9	1.27
207	5810	25800	3440	15300	6850	4800	8400	7/16	9	1.72
208	7330	32600	4460	19900	6000	4500	7500	1/2	9	2.25
209	7370	32800	4590	20400	5330	4000	6800	1/2	9	2.25
210	7920	35200	5220	23200	4800	3600	6400	1/2	10	2.50
211	9800	43600	6570	29200	4360	3200	5800	9/16	10	3.16
212	11840	52700	8080	36000	4000	3000	5300	5/8	10	3.91
214	14040	62450	8620	38300	3050	2850	4600	11/16	10	4.73
215	15080	67000	11100	49200	3300	2700	4400	11/16	11	5.20
216	17420	77500	11400	50700	2700	2550	4050	3/4	11	6.19
218	21580	95990	14400	64000	2400	2250	3600	7/8	10	7.66

If the load P is greater than 15% of the C rating for S200 and 25% of the C rating for CL200, consult Rexnord Bearing Division.

For S200 Series reduce C Basic Load Rating by 23%.

For CL200 Series reduce C Basic Load Rating by 15%.

* Based on grease lubrication and moderate load.

‡ E seals operation at higher speeds up to N seal speed limit is allowable providing the lip seal friction does not result in operating temperatures over 225°F (107°C).

Table 4 - Load Ratings

Size Code	L10 Minimum life, hours	Radial Load Ratings, Pounds																		
		Speed, RPM																		
		50	100	200	300	400	500	600	700	800	900	1000	1200	1500	1800	2000	2500	3000	3500	
206	8000	1523	1209	960	838	762	707	665	632	605	581	561	528	490	461	445	413	389	370	
	20000	1122	891	707	618	561	521	490	466	445	428	413	389	361	340	328	305	287	272	
	40000	891	707	561	490	445	413	389	370	354	340	328	309	287	270	260	242	228	216	
	100000	656	521	413	361	328	305	287	272	260	250	242	228	211	199	192	178	168	159	
207	8000	2015	1599	1269	1109	1007	935	880	836	799	769	742	698	648	610	589	547	515	489	
	20000	1484	1178	935	817	742	689	648	616	589	566	547	515	478	450	434	403	379	360	
	40000	1178	935	742	648	589	547	515	489	468	450	434	408	379	357	344	320	301	286	
	100000	868	689	547	478	434	403	379	360	344	331	320	301	279	263	254	236	222	211	
208	8000	2542	2017	1601	1399	1271	1180	1110	1055	1009	970	936	881	818	770	743	690	649	617	
	20000	1873	1486	1180	1031	936	869	818	777	743	715	690	649	603	567	548	508	478	454	
	40000	1486	1180	936	818	743	690	649	617	590	567	548	515	478	450	435	403	380	361	
	100000	1095	869	690	603	548	508	478	454	435	418	403	380	352	332	320	297	280	266	
209	8000	2555	2028	1610	1406	1278	1186	1116	1060	1014	975	941	886	822	774	747	694	653	620	
	20000	1883	1494	1186	1036	941	874	822	781	747	718	694	653	606	570	551	511	481	457	
	40000	1494	1186	941	822	747	694	653	620	593	570	551	518	481	453	437	406	382	363	
	100000	1101	874	694	606	551	511	481	457	437	420	406	382	354	333	322	299	281	267	
210	8000	2745	2178	1729	1510	1372	1274	1199	1139	1089	1047	1011	952	883	831	803	745	701	666	
	20000	2022	1605	1274	1113	1011	939	883	839	803	772	745	701	651	612	591	549	517	491	
	40000	1605	1274	1011	883	803	745	701	666	637	612	591	556	517	486	469	436	410	389	
	100000	1183	939	745	651	591	549	517	491	469	451	436	410	381	358	346	321	302	287	
211	8000	3398	2697	2141	1870	1699	1577	1484	1410	1349	1297	1252	1178	1094	1029	994	922	868	825	
	20000	2504	1987	1577	1378	1252	1162	1094	1039	994	955	922	868	806	758	732	680	640	608	
	40000	1987	1577	1252	1094	994	922	868	825	789	758	732	689	640	602	581	539	508	482	
	100000	1464	1162	922	806	732	680	640	608	581	559	539	508	471	443	428	397	374	355	
212	8000	4106	3259	2586	2259	2053	1906	1793	1704	1629	1567	1513	1423	1321	1243	1201	1114	1049	996	
	20000	3025	2401	1906	1665	1513	1404	1321	1255	1201	1154	1114	1049	974	916	885	821	773	734	
	40000	2401	1906	1513	1321	1201	1114	1049	996	953	916	885	832	773	727	702	652	613	583	
	100000	1769	1404	1114	974	885	821	773	734	702	675	652	613	569	536	517	480	452	429	
214	8000	4867	3863	3066	2679	2434	2259	2126	2020	1932	1857	1793	1687	1566	1474	1423	1321	1243	1181	
	20000	3586	2846	2259	1974	1793	1665	1566	1488	1423	1368	1321	1243	1154	1086	1049	973	916	870	
	40000	2846	2259	1793	1566	1423	1321	1243	1181	1130	1086	1049	987	916	862	832	773	727	691	
	100000	2097	1665	1321	1154	1049	973	916	870	832	800	773	727	675	635	613	569	536	509	
215	8000	5228	4149	3293	2877	2614	2427	2284	2169	2075	1995	1926	1812	1683	1583	1529	1419	1335	1275	
	20000	3852	3057	2427	2120	1926	1788	1683	1598	1529	1470	1419	1335	1240	1167	1126	1046	984	943	
	40000	3057	2427	1926	1683	1529	1419	1335	1269	1213	1167	1126	1060	984	926	894	830	781	741	
	100000	2253	1788	1419	1240	1126	1046	984	935	894	860	830	781	725	682	659	611	575	543	
216	8000	6039	4793	3804	3323	3020	2803	2638	2506	2397	2304	2225	2094	1944	1829	1766	1639	1535	1455	
	20000	4450	3532	2803	2449	2225	2065	1944	1846	1766	1698	1639	1543	1432	1348	1301	1208	1137	1079	
	40000	3532	2803	2225	1944	1766	1639	1543	1465	1402	1348	1301	1224	1137	1070	1033	959	903	859	
	100000	2602	2065	1639	1432	1301	1208	1137	1080	1033	993	959	902	837	788	761	706	659	623	
218	8000	7481	5938	4713	4117	3741	3473	3268	3104	2969	2855	2756	2594	2408	2266	2188	2088	1998	1918	
	20000	5512	4375	3473	3034	2756	2559	2408	2287	2188	2103	2031	1911	1774	1669	1612	1522	1442	1372	
	40000	4375	3473	2756	2408	2188	2031	1911	1815	1736	1669	1612	1517	1408	1325	1279	1209	1149	1099	
	100000	3224	2559	2031	1774	1612	1496	1408	1338	1279	1230	1188	1118	1037	976	943	883	833	793	

If the load P is greater than 15% of the C rating for S200 and 25% of the C rating for CL200, consult Rexnord Bearing Division.

For S200 Series reduce C Basic Load Rating by 23%.

For CL200 Series reduce C Basic Load Rating by 15%.

Operation in the high speed shaded areas requires frequent lubrication.

MPCL200N

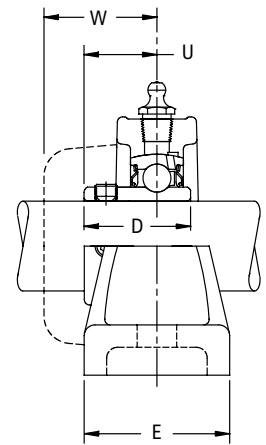
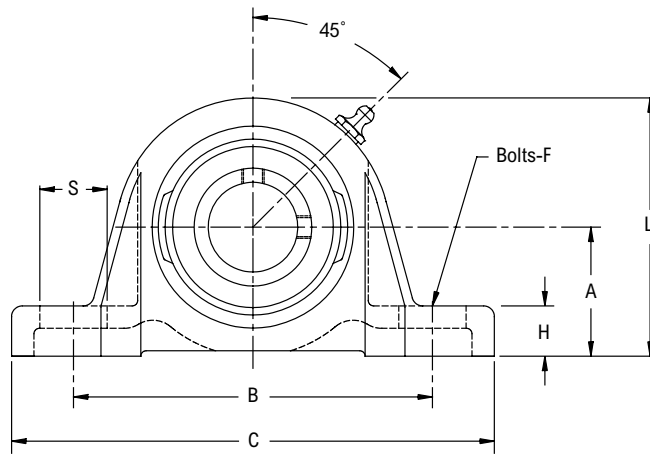
Interchange: P2BDLM, MP-T



Photo Shows a 2-Bolt Ball Bearing Pillow Block Unit

Product Features

- Corrosion-resistant powder coating
- Cast iron housing
- Broad range of sealing options
- Centrik-Lok shaft locking device
- Alignable & relubricatable
- See Features and Benefits for additional info on pages 400 - 401.



Bearing Dimensions

Size Code	Shaft Diameter	Part Number	A Base to Centerline Height	B Distance Between Bolt Holes	C	D	E	F Bolts	H	L	M Collar O.D.	S	U	Approx. Weight
206	1	MPCL216N◆●□△	1 11/16	4 5/8	6 5/16	1 5/16	1 5/8	1/2	11/16	3 5/16	2 19/32	15/16	29/32	2.54
207	1 3/16	MPCL219N◆●□△	1 7/8	4 15/16	6 3/8	1 31/64	1 3/4	1/2	13/16	3 11/16	3 1/16	7/8	1 1/32	3.58
208	1 7/16	MPCL223N◆●□△	2 1/8	5 3/8	7 1/16	1 25/32	1 7/8	1/2	15/16	4 1/8	3 3/16	15/16	1 7/32	4.65
209	1 1/2	MPCL224N◆●□△	2 1/8	5 11/16	7 1/4	1 25/32	2	1/2	13/16	4 5/16	3 3/8	1	1 7/32	5.40
210	1 11/16	MPCL227N◆●□△	2 1/4	6 3/16	7 7/8	1 51/64	2 1/8	5/8	7/8	4 9/16	3 3/4	15/16	1 5/16	6.53
	1 3/4	MPCL228N◆●□△												
211	1 15/16	MPCL231N◆●□△	2 1/2	6 29/32	8 7/8	1 57/64	2 5/16	5/8	1	5	4 3/32	1 7/32	1 11/32	7.87
	2	MPCL232N◆●□△												
212	2 3/16	MPCL235N◆●□△	2 3/4	7 1/2	9 1/2	2 5/32	2 3/8	5/8	1 3/16	5 7/16	4 9/32	1 1/8	1 19/32	10.24
214	2 7/16	MPCL239N●□△◆	3	8 1/4	10 3/4	2 5/16	2 11/16	3/4	1 5/32	6	4 13/16	1 1/2	1 21/32	13.31
	2 1/2	MPCL240N●□△◆												
215	2 11/16	MPCL243N●□△◆	3 1/2	9 1/8	12	2 23/64	2 7/8	7/8	1 7/32	6 21/32	5 1/4	1 7/8	1 11/16	17.36
216	2 15/16	MPCL247N●□△◆	3 1/2	9 1/4	12	2 25/32	3	7/8	1 9/32	6 7/8	5 47/64	1 3/4	2 5/64	19.32
	3	MPCL248N●□△◆												
218	3 3/16	MPCL251N●□△◆	4	10 7/8	14	2 19/32	3 3/8	7/8	1 11/32	7 7/8	5 47/64	1 15/16	1 25/32	27.52
	3 7/16	MPCL255N●□△◆												
	3 1/2	MPCL256N●□△◆												

Additional Notes

- Please call 1-866-REXNORD for availability
- Lubrication fitting tap size, 1/8 in PT
- Base to centerline tolerance, +/- .005 in (+/- 0.13 mm)
- Lip seals standard
- ◆ Available with E1 viton seals
- Available with free running style seals, add suffix ● FF, □ HFF or △ MHFF
- Nickel plated housings available through all size codes, add suffix K75

For the Selection Guide, Load Ratings and Speed Limits, see the Link Belt 200 Series Medium Duty Ball Bearings Engineering section on pages 404 - 407.
 Note: Dimensions subject to change. Certified dimensions of ordered material furnished on request.

MPS200N

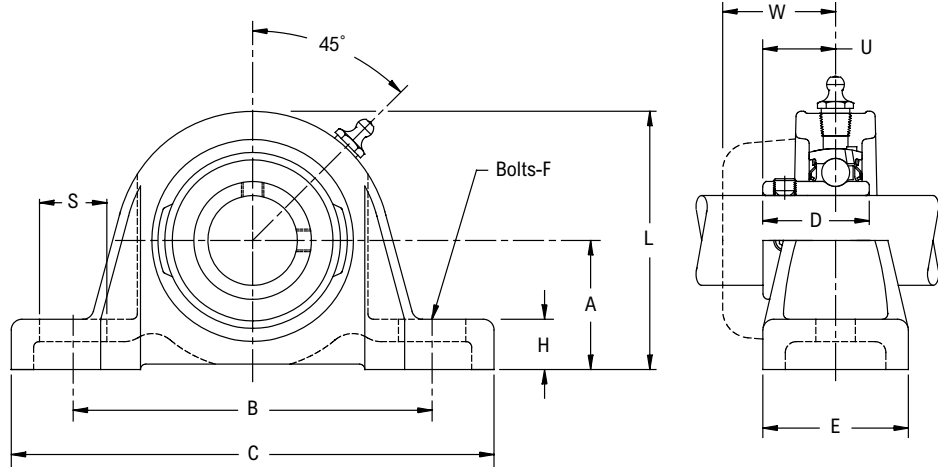
Interchange: P2BSCM, SYM-TF, UCPX, MP, YASM



Photo Shows a 2-Bolt Ball Bearing Pillow Block Unit

Product Features

- Corrosion-resistant powder coating
- Cast iron housing
- Broad range of sealing options
- Spring locking setscrew mount
- Alignable & relubricatable
- See Features and Benefits for additional info on pages 400 - 401.



Bearing Dimensions

Size Code	Shaft Diameter	Part Number	A Base to Centerline Height	B Distance Between Bolt Holes	C	D	E	F Bolts	H	L	S	U	Approx. Weight
206	1	MPS216N◆●□△	1 11/16	4 5/8	6 5/16	1 11/32	1 5/8	1/2	11/16	3 5/16	15/16	61/64	2.54
207	1 3/16	MPS219N◆●□△	1 7/8	4 15/16	6 3/8	1 9/16	1 3/4	1/2	13/16	3 11/16	7/8	1 7/64	3.58
208	1 7/16	MPS223N◆●□△	2 1/8	5 3/8	7 1/16	1 21/32	1 7/8	1/2	15/16	4 1/8	15/16	1 11/64	4.65
209	1 1/2	MPS224N◆●□△	2 1/8	5 11/16	7 1/4	1 49/64	2	1/2	13/16	4 5/16	1	1 15/64	5.40
210	1 11/16	MPS227N◆●□△	2 1/4	6 3/16	7 7/8	1 13/16	2 1/8	5/8	7/8	4 9/16	15/16	1 17/64	6.53
	1 3/4	MPS228N◆●□△											
211	1 15/16	MPS231N◆●□△	2 1/2	6 29/32	8 7/8	1 13/16	2 5/16	5/8	1	5	1 7/32	1 9/32	7.87
	2	MPS232N◆●□△											
212	2 3/16	MPS235N◆●□△	2 3/4	7 1/2	9 1/2	1 57/64	2 3/8	5/8	1 3/16	5 7/16	1 1/8	1 5/16	10.24
214	2 7/16	MPS239N◆●□△	3	8 1/4	10 3/4	2 15/64	2 11/16	3/4	1 5/32	6	1 1/2	1 7/16	13.31
	2 1/2	MPS240N◆●□△											
215	2 11/16	MPS243N◆●□△	3 1/2	9 1/8	12	2 17/64	2 7/8	7/8	1 7/32	6 21/32	1 7/8	1 15/32	17.36
216	2 15/16	MPS247N◆●□△	3 1/2	9 1/4	12	2 23/64	3	7/8	1 9/32	6 7/8	1 3/4	1 1/2	19.32
	3	MPS248N◆●□△											
218	3 3/16	MPS251N◆●□△	4	10 7/8	14	2 33/64	3 3/8	7/8	1 11/32	7 7/8	1 15/16	1 9/16	27.52
	3 7/16	MPS255N◆●□△											
	3 1/2	MPS256N◆●□△											

Additional Notes

- Please call 1-866-REXNORD for availability
- Lubrication fitting tap size, 1/8 in PT
- Base to centerline tolerance, +/- .005 in (+/- 0.13 mm)
- Lip seals standard
- ◆ Available with E1 viton seals for all sizes
- Available with free running style seals, add suffix ● FF, □ HFF or △ MHFF for all size codes

For the Selection Guide, Load Ratings and Speed Limits, see the Link Belt 200 Series Medium Duty Ball Bearings Engineering section on pages 404 - 407.

Note: Dimensions subject to change. Certified dimensions of ordered material furnished on request.

MFXCL200N

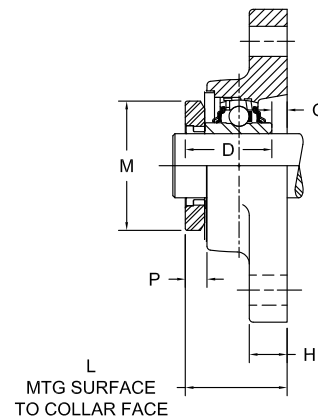
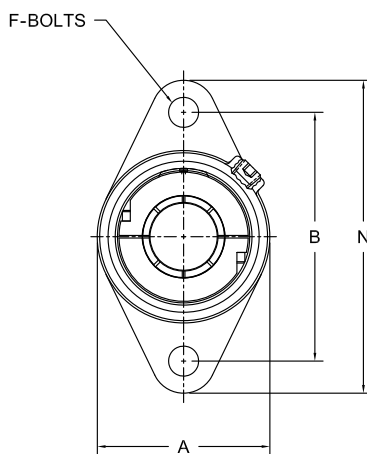
Interchange: F2BDLM, MSFT-T



Photo Shows a 2-Bolt Ball Bearing Flanged Unit

Product Features

- Corrosion-resistant powder coating
- Cast iron housing
- Broad range of sealing options
- Centrik-Lok shaft locking device
- Alignable & relubricatable
- See Features and Benefits for additional info on pages 400 - 401.



Bearing Dimensions

Size Code	Shaft Diameter	Part Number	B Distance Between Bolt Holes	L Mounting Surface to Collar Face	A	D	F Bolts	G	H	M Collar O.D.	N	P	Approx. Weight
206	1	MFXCL216N◆●□△	4 ¹⁹ / ₃₂	1 ⁷ / ₁₆	3 ³ / ₁₆	1 ⁵ / ₁₆	⁷ / ₁₆	¹ / ₈	¹⁷ / ₃₂	2 ¹⁹ / ₃₂	5 ⁹ / ₁₆	⁹ / ₁₆	2.54
207	1 ³ / ₁₆	MFXCL219N◆●□△	5 ¹ / ₈	1 ⁵ / ₈	3 ¹¹ / ₁₆	1 ¹⁵ / ₃₂	¹ / ₂	⁵ / ₃₂	⁹ / ₁₆	3 ¹ / ₁₆	6 ¹ / ₈	²¹ / ₃₂	3.32
208	1 ⁷ / ₁₆	MFXCL223N◆●□△	5 ²¹ / ₃₂	1 ⁵⁵ / ₆₄	4 ¹ / ₈	1 ²⁵ / ₃₂	¹ / ₂	¹¹ / ₆₄	⁹ / ₁₆	3 ³ / ₁₆	6 ³ / ₄	²¹ / ₃₂	4.55
209	1 ¹ / ₂	MFXCL224N◆●□△	5 ²⁷ / ₃₂	1 ⁷ / ₈	4 ³ / ₈	1 ²⁵ / ₃₂	⁹ / ₁₆	¹¹ / ₆₄	⁹ / ₁₆	3 ³ / ₈	7 ¹ / ₁₆	²³ / ₃₂	5.03
210	1 ¹¹ / ₁₆	MFXCL227N◆●□△	6 ³ / ₁₆	1 ⁶¹ / ₆₄	4 ⁹ / ₁₆	1 ⁵¹ / ₆₄	⁹ / ₁₆	⁵ / ₃₂	⁵ / ₈	3 ³ / ₄	7 ¹⁵ / ₃₂	²³ / ₃₂	5.59
	1 ³ / ₄	MFXCL228N◆●□△											
211	1 ¹⁵ / ₁₆	MFXCL231N◆●□△	7 ¹ / ₄	2 ⁵ / ₁₆	5	1 ⁵⁷ / ₆₄	⁵ / ₈	⁵ / ₃₂	⁵ / ₈	4 ³ / ₃₂	8 ¹ / ₂	¹¹ / ₁₆	7.69
	2	MFXCL232N◆●□△											

Additional Notes

- Please call 1-866-REXNORD for availability
- Lubrication fitting tap size, 1/8 in PT
- Lip seals standard
- ◆ Available with E1 viton seals
- Available with free running style seals, add suffix ● FF, □ HFF or △ MHFF
- Nickel plated housings available through all size codes, add suffix K75

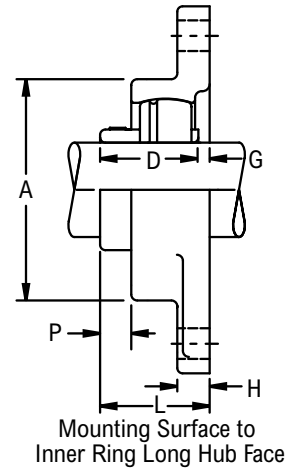
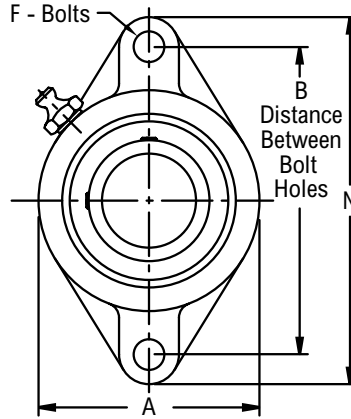
For the Selection Guide, Load Ratings and Speed Limits, see the Link Belt 200 Series Medium Duty Ball Bearings Engineering section on pages 404 - 407.
 Note: Dimensions subject to change. Certified dimensions of ordered material furnished on request.

MFXS200

Interchange: F2BSCM, FYTM-TF, UCFTX, MSFT, YCJTM



Photo Shows a 2-Bolt Ball Bearing Flanged Unit



Product Features

- Corrosion-resistant powder coating
- Cast iron housing
- Broad range of sealing options
- Spring locking setscrew mount
- Alignable & relubricatable
- See Features and Benefits for additional info on pages 400 - 401.

Bearing Dimensions

Size Code	Shaft Diameter	Part Number	B Distance Between Bolt Holes	L Mounting Surface to Inner Ring Long Hub Face	A	D	F Bolts	G	H	N	P	Approx. Weight
206	1	MFXS216N	4 ¹⁹ / ₃₂	1 ¹ / ₂	3 ³ / ₁₆	1 ¹¹ / ₃₂	⁷ / ₁₆	⁹ / ₆₄	¹⁷ / ₃₂	5 ⁹ / ₁₆	⁹ / ₁₆	1.79
	30.00	MFXS2M30N	116.68	38.10	81.00	34.14	10.00	3.60	13.50	141.30	14.30	0.80
207	1 ³ / ₁₆	MFXS219N	5 ¹ / ₈	1 ²³ / ₃₂	3 ¹¹ / ₁₆	1 ⁹ / ₁₆	¹ / ₂	⁵ / ₃₂	⁹ / ₁₆	6 ¹ / ₈	²¹ / ₃₂	2.69
	35.00	MFXS2M35N	130.18	43.70	93.70	39.67	12.00	3.60	14.30	155.60	16.70	1.20
208	1 ⁷ / ₁₆	MFXS223N	5 ²¹ / ₃₂	1 ¹³ / ₁₆	4 ¹ / ₈	1 ²¹ / ₃₂	¹ / ₂	¹¹ / ₆₄	⁹ / ₁₆	6 ³ / ₄	²¹ / ₃₂	3.47
	40.00	MFXS2M40N	143.67	46.00	104.80	42.06	12.00	4.00	14.30	171.40	16.70	1.50
209	1 ¹ / ₂	MFXS224N	5 ²⁷ / ₃₂	1 ²⁹ / ₃₂	4 ³ / ₈	1 ⁴⁹ / ₆₄	⁹ / ₁₆	¹¹ / ₆₄	⁹ / ₁₆	7 ¹ / ₁₆	²³ / ₃₂	3.46
210	1 ¹¹ / ₁₆	MFXS227N	6 ³ / ₁₆	1 ²⁹ / ₃₂	4 ⁹ / ₁₆	1 ¹³ / ₁₆	⁹ / ₁₆	⁵ / ₃₂	⁵ / ₈	7 ¹⁵ / ₃₂	²³ / ₃₂	4.43
	1 ³ / ₄	MFXS228N										4.34
211	1 ¹⁵ / ₁₆	MFXS231N	7 ¹ / ₄	2	5	1 ¹³ / ₁₆	⁵ / ₈	⁵ / ₃₂	²³ / ₃₂	8 ¹ / ₂	¹¹ / ₁₆	5.74
	2	MFXS232N										6.04

Additional Notes

- Please call 1-866-REXNORD for availability
- Lubrication fitting tap size: for size codes 203 thru 205, 1/4-28 UNF; for all other size codes, 1/8 in PT
- Lip seals standard
- ◆ Available with E1 viton seals
- Available with free running style seals, add suffix ● FF, □ HFF or Δ MHFF
- Nickel plated housings available, add suffix K75

For the Selection Guide, Load Ratings and Speed Limits, see the Link Belt 200 Series Medium Duty Ball Bearings Engineering section on pages 404 - 407.

Note: Dimensions subject to change. Certified dimensions of ordered material furnished on request.

MFCL200N

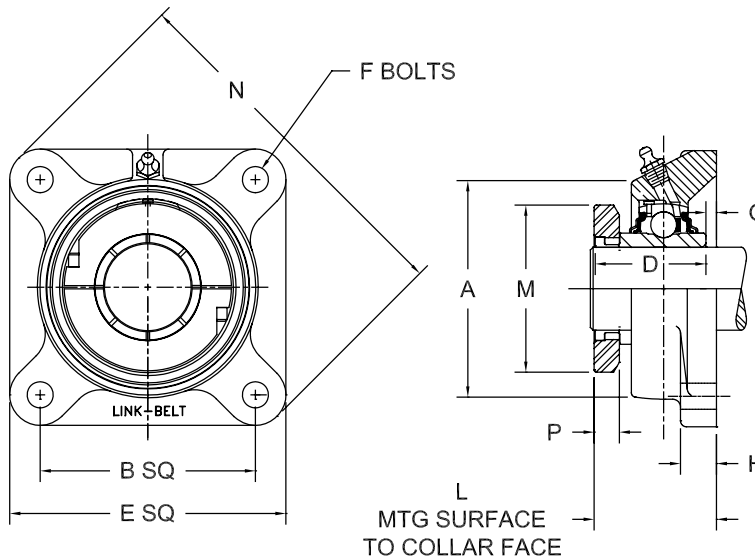
Interchange: F4BDLM, MSF-T



Photo Shows a 4-Bolt Ball Bearing Flanged Unit

Product Features

- Corrosion-resistant powder coating
- Cast iron housing
- Broad range of sealing options
- Centrik-Lok shaft locking device
- Alignable & relubricatable
- See Features and Benefits for additional info on pages 400 - 401.



Bearing Dimensions

Size Code	Shaft Diameter	Part Number	B Distance Between Bolt Holes	L Mounting Surface to Collar Face	A	D	E	F Bolts	G	H	M Collar O.D.	N	P	Approx. Weight
206	1	MFCL216N◆●□△	3 1/4	1 7/16	3 3/16	1 5/16	4 1/4	7/16	1/8	1/2	2 19/32	5 19/32	9/16	2.54
207	1 3/16	MFCL219N◆●□△	3 5/8	1 5/8	3 11/16	1 15/32	4 5/8	1/2	5/32	1/2	3 1/16	6 1/8	21/32	3.32
208	1 7/16	MFCL223N◆●□△	4	1 55/64	4 1/16	1 25/32	5 1/4	1/2	11/64	9/16	3 3/16	6 25/32	21/32	4.55
209	1 1/2	MFCL224N◆●□△	4 1/8	1 7/8	4 5/16	1 25/32	5 3/8	9/16	11/64	9/16	3 3/8	7 3/32	23/32	5.03
210	1 11/16	MFCL227N◆●□△	4 3/8	1 61/64	4 1/2	1 51/64	5 5/8	9/16	5/32	9/16	3 3/4	7 7/16	23/32	5.59
	1 3/4	MFCL228N◆●□△												
211	1 15/16	MFCL231N◆●□△	5 1/8	2 5/16	5 3/16	1 57/64	6 3/8	5/8	5/32	5/8	4 3/32	8 1/2	11/16	7.69
	2	MFCL232N◆●□△												
212	2 3/16	MFCL235N◆●□△	5 5/8	2 3/8	5 7/16	2 5/32	6 7/8	5/8	13/64	11/16	4 9/32	9 9/32	21/32	9.34
	2 1/4	MFCL236N◆●□△												
214	2 7/16	MFCL239N●□△◆	5 7/8	2 19/32	6 1/8	2 5/16	7 3/8	5/8	19/64	11/16	4 13/16	9 13/16	23/32	12.27
	2 1/2	MFCL240N●□△◆												
215	2 11/16	MFCL243N●□△◆	6	2 25/32	6 7/16	2 23/64	7 3/4	3/4	9/32	3/4	5 1/4	10 1/4	23/32	13.75
216	2 15/16	MFCL247N●□△◆	6	3 7/64	6 3/4	2 25/32	7 3/4	3/4	21/64	13/16	5 47/64	10 1/4	11/16	15.25
	3	MFCL248N●□△◆												
218	3 3/16	MFCL251N●□△◆	6 3/4	2 31/32	7 3/4	2 19/32	8 7/16	3/4	3/8	15/16	5 47/64	11 1/4	11/16	21.10
	3 7/16	MFCL255N●□△◆												
	3 1/2	MFCL256N●□△◆												

Additional Notes

- Please call 1-866-REXNORD for availability
- Lubrication fitting tap size, 1/8 in PT
- Lip seals standard
- ◆ Available with E1 viton seals
- Available with free running style seals, add suffix ● FF, □ HFF or △ MHFF
- Nickel plated housings available through all size codes, add suffix K75

For the Selection Guide, Load Ratings and Speed Limits, see the Link Belt 200 Series Medium Duty Ball Bearings Engineering section on pages 404 - 407.
 Note: Dimensions subject to change. Certified dimensions of ordered material furnished on request.

MFS200N

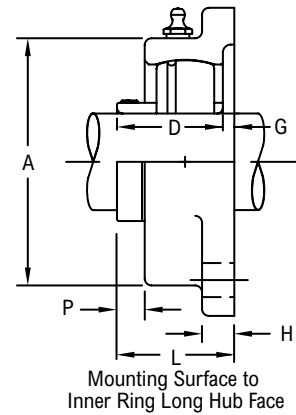
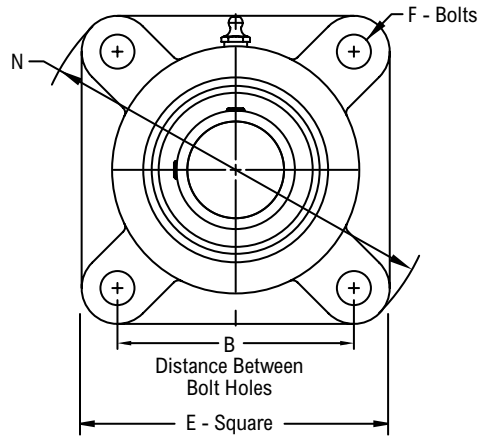
Interchange: F4BSCM, FYM-TF, UCFX, MSF, YCJM



Photo Shows a 4-Bolt Ball Bearing Flanged Unit

Product Features

- Corrosion-resistant powder coating
- Cast iron housing
- Broad range of sealing options
- Spring locking setscrew mount
- Alignable & relubricatable
- See Features and Benefits for additional info on pages 400 - 401.



Bearing Dimensions

Size Code	Shaft Diameter	Part Number	B Distance Between Bolt Holes	L Mounting Surface to Inner Ring Long Hub Face	A	D	E	F Bolts	G	H	N	P	Approx. Weight
206	1	MFS216N◆●□△	3 1/4	1 1/2	3 3/16	1 11/32	4 1/4	7/16	9/64	1/2	5 19/32	9/16	2.58
207	1 3/16	MFS219N◆●□△	3 5/8	1 23/32	3 11/16	1 9/16	4 5/8	1/2	9/64	1/2	6 1/8	21/32	3.32
208	1 7/16	MFS223N◆●□△	4	1 13/16	4 1/16	1 21/32	5 1/4	1/2	5/32	9/16	6 25/32	21/32	4.55
209	1 1/2	MFS224N◆●□△	4 1/8	1 29/32	4 5/16	1 49/64	5 3/8	1/2	1/8	9/16	7 3/32	23/32	5.03
210	1 11/16	MFS227N◆●□△	4 3/8	1 29/32	4 1/2	1 13/16	5 5/8	9/16	7/64	9/16	7 7/16	23/32	5.59
	1 3/4	MFS228N◆●□△											
211	1 15/16	MFS231N◆●□△	5 1/8	2	5 3/16	1 13/16	6 3/8	5/8	11/64	5/8	8 1/2	11/16	7.69
	2	MFS232N◆●□△											
212	2 3/16	MFS235N◆●□△	5 5/8	2 3/32	5 7/16	1 57/64	6 7/8	5/8	13/64	11/16	9 9/32	21/32	9.34
214	2 7/16	MFS239N◆●□△	5 7/8	2 3/8	6 1/8	2 15/64	7 3/8	5/8	1/8	11/16	9 13/16	23/32	12.27
	2 1/2	MFS240N◆●□△											
215	2 11/16	MFS243N◆●□△	6	2 13/32	6 7/16	2 17/64	7 3/4	3/4	1/8	3/4	10 1/4	23/32	13.75
216	2 15/16	MFS247N◆●□△	6	2 17/32	6 3/4	2 23/64	7 3/4	3/4	11/64	13/16	10 1/4	11/16	15.25
	3	MFS248N◆●□△											
218	3 3/16	MFS251N◆●□△	6 3/4	2 47/64	7 3/4	2 33/64	8 7/16	3/4	7/32	15/16	11 1/4	21/32	21.10
	3 7/16	MFS255N◆●□△											
	3 1/2	MFS256N◆●□△											

Additional Notes

- Please call 1-866-REXNORD for availability
- Lubrication fitting tap size, 1/8 in PT
- Lip seals standard
- ◆ Available with E1 viton seals for all sizes
- Available with free running style seals, add suffix ● FF, □ HFF or △ MHFF for all size codes

For the Selection Guide, Load Ratings and Speed Limits, see the Link Belt 200 Series Medium Duty Ball Bearings Engineering section on pages 404 - 407.

Note: Dimensions subject to change. Certified dimensions of ordered material furnished on request.

MFCCL200N

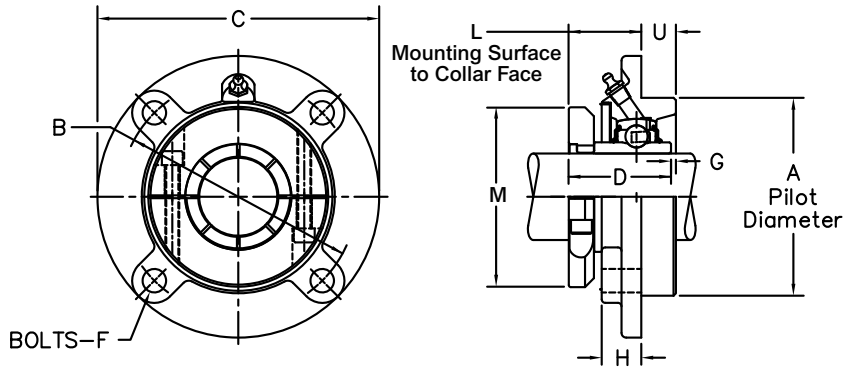
Interchange: FCDLM, MFC-T



Photo Shows a 4-Bolt Ball Bearing Flanged Cartridge Unit

Product Features

- Corrosion-resistant powder coating
- Cast iron housing
- Broad range of sealing options
- Centrik-Lok shaft locking device
- Alignable & relubricatable
- See Features and Benefits for additional info on pages 400 - 401.



Bearing Dimensions

Size Code	Shaft Diameter	Part Number	A Pilot Diameter	B Bolt Hole Circle Diameter	L Mounting Surface to Collar Face	C	D	F Bolts	G & G1	H	M Collar O.D.	U	Approx. Weight
207	1 3/16	MFCCL219N◆●□△	3.375	4 1/8	1 7/16	5	1 15/32	7/16	11/64	7/8	3 1/16	3/8	3.14
208	1 7/16	MFCCL223N◆●□△	3.625	4 3/8	1 37/64	5 1/4	1 25/32	7/16	5/32	7/8	3 3/16	7/16	3.69
209	1 1/2	MFCCL224N◆●□△	3.625	4 3/8	1 9/16	5 1/4	1 25/32	7/16	11/64	7/8	3 3/8	7/16	3.85
210	1 11/16	MFCCL227N◆●□△	4.250	5 1/8	1 21/32	6 1/8	1 51/64	1/2	11/64	7/8	3 3/4	15/32	5.72
	1 3/4	MFCCL228N◆●□△											
211	1 15/16	MFCCL231N◆●□△	4.500	5 3/8	1 39/64	6 3/8	1 57/64	1/2	15/64	7/8	4 3/32	5/8	5.96
	2	MFCCL232N◆●□△											
212	2 3/16	MFCCL235N◆●□△	5.000	6	1 15/16	7 1/8	2 5/32	9/16	37/64	1	4 9/32	1	8.52
	2 1/4	MFCCL236N◆●□△											
214	2 7/16	MFCCL239N◆●□△	5.500	6 1/2	1 15/16	7 5/8	2 5/16	9/16	1/4	1	4 13/16	1	10.27
	2 1/2	MFCCL240N◆●□△											
215	2 11/16	MFCCL243N◆●□△	6.375	7 1/2	1 15/16	8 3/4	2 23/64	5/8	1/4	1	5 1/4	1	14.07
216	2 15/16	MFCCL247N◆●□△	6.375	7 1/2	2 17/64	8 3/4	2 25/32	5/8	11/64	1 1/8	5 47/64	1	14.28
	3	MFCCL248N◆●□△											
218	3 3/16	MFCCL251N◆●□△	7.375	8 5/8	2 1/64	10 1/4	2 19/32	3/4	5/32	1 1/8	5 47/64	1 1/8	21.90
	3 7/16	MFCCL255N◆●□△											
	3 1/2	MFCCL256N◆●□△											

Additional Notes

- Please call 1-866-REXNORD for availability
- Lubrication fitting tap size, 1/8 in PT
- Pilot Diameter tolerance, +.000 in/- .002 in (+0.00 mm/-0.05 mm)
- Bore tolerance for mounting, +.002 in/- .000 in (+0.05 mm/-0.00 mm)
- For size codes 207 & 212, use the G dimension; for all other size codes use G1
- Lip seals standard
- ◆ Available with E1 viton seals
- Available with free running style seals, add suffix ● FF, □ HFF or △ MHFF

Nickel plated housings available through all size codes, add suffix K75
 For the Selection Guide, Load Ratings and Speed Limits, see the Link Belt 200 Series Medium Duty Ball Bearings Engineering section on pages 404 - 407.
 Note: Dimensions subject to change. Certified dimensions of ordered material furnished on request.

MFCS200N

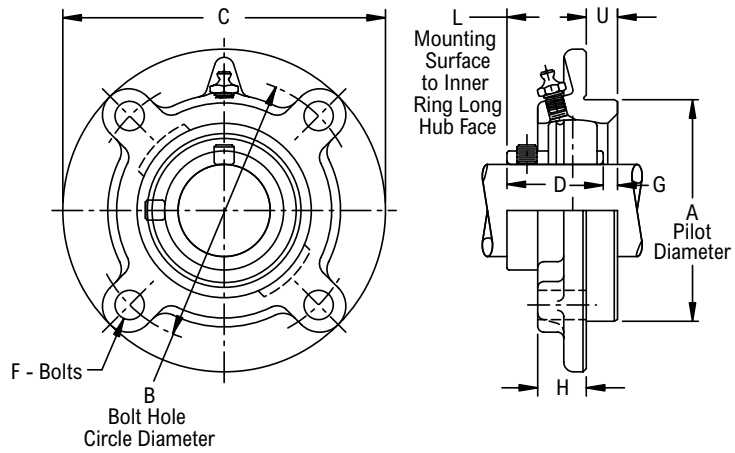
Interchange: FCSCM, MFC, RFC



Photo Shows a 4-Bolt Ball Bearing Flanged Cartridge Unit

Product Features

- Corrosion-resistant powder coating
- Cast iron housing
- Broad range of sealing options
- Spring locking setscrew mount
- Alignable & relubricatable
- See Features and Benefits for additional info on pages 400 - 401.



Bearing Dimensions

Size Code	Shaft Diameter	Part Number	A Pilot Diameter	B Bolt Hole Circle Diameter	L Mounting Surface to Inner Ring Long Hub Face	C	D	F Bolts	G	H	U	Approx. Weight
207	1 3/16	MFCS219N◆●□△	3.375	4 1/8	1 33/64	5	1 9/16	7/16	17/64	7/8	3/8	3.14
208	1 7/16	MFCS223N◆●□△	3.625	4 3/8	1 17/32	5 1/4	1 21/32	7/16	1/4	7/8	7/16	3.69
209	1 1/2	MFCS224N◆●□△	3.625	4 3/8	1 37/64	5 1/4	1 49/64	7/16	3/16	7/8	7/16	3.85
210	1 11/16	MFCS227N◆●□△	4.250	5 1/8	1 19/32	6 1/8	1 13/16	1/2	13/64	7/8	15/32	5.72
	1 3/4	MFCS228N◆●□△										
211	1 15/16	MFCS231N◆●□△	4.500	5 3/8	1 35/64	6 3/8	1 13/16	1/2	19/64	7/8	5/8	5.96
	2	MFCS232N◆●□△										
212	2 3/16	MFCS235N◆●□△	5.000	6	1 11/64	7 1/8	1 57/64	9/16	37/64	1	1	8.52
214	2 7/16	MFCS239N◆●□△	5.500	6 1/2	1 23/32	7 5/8	2 15/64	9/16	27/64	1	1	10.27
	2 1/2	MFCS240N◆●□△										
215	2 11/16	MFCS243N◆●□△	6.375	7 1/2	1 23/32	8 3/4	2 17/64	5/8	25/64	1	1	14.07
216	2 15/16	MFCS247N◆●□△	6.375	7 1/2	1 11/16	8 3/4	2 23/64	5/8	21/64	1 1/8	1	13.92
	3	MFCS248N◆●□△										
218	3 3/16	MFCS251N◆●□△	7.375	8 5/8	1 51/64	10 1/4	2 33/64	3/4	25/64	1 1/8	1 1/8	21.50
	3 7/16	MFCS255N◆●□△										
	3 1/2	MFCS256N◆●□△										

Additional Notes

- Please call 1-866-REXNORD for availability
- Lubrication fitting tap size, 1/8 in PT
- Pilot Diameter tolerance, +.000 in/- .002 in (*+0.00 mm/-0.05 mm*)
- Bore tolerance for mounting, +.002 in/- .000 in (*+0.05 mm/-0.00 mm*)
- Lip seals standard
- ◆ Available with E1 viton seals for all sizes
- Available with free running style seals, add suffix ● FF, □ HFF or △ MHFF for all size codes

For the Selection Guide, Load Ratings and Speed Limits, see the Link Belt 200 Series Medium Duty Ball Bearings Engineering section on pages 404 - 407.
 Note: Dimensions subject to change. Certified dimensions of ordered material furnished on request.

MTHCL200N

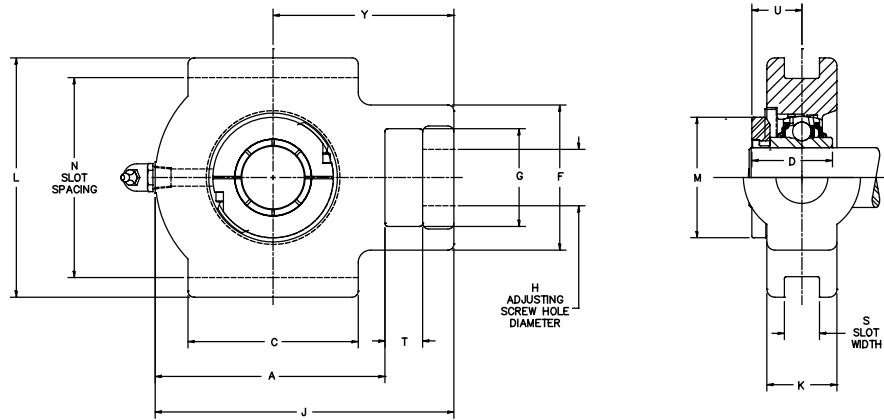
Interchange: WSTUDLM, MST-T



Photo Shows a Ball Bearing Take-up Unit

Product Features

- Corrosion-resistant powder coating
- Cast iron housing
- Wide slot design
- Broad range of sealing options
- Centrik-Lok shaft locking device
- Alignable & relubricatable
- See Features and Benefits for additional info on pages 400 - 401.



Bearing Dimensions

Size Code	Shaft Diameter	Part Number	H Adjusting Screw Hole Diameter	N Slot Spacing	S Slot Width	A	C	D	F	G	J	K	L	M Collar O.D.	T	U	Y	Approx. Weight
206	1	MTHCL216N◆●□Δ	7/8	3.500	0.531	3 3/8	2 1/4	1 5/16	2 3/16	1 7/16	4 1/2	1 9/16	4 1/8	2 19/32	1 11/16	2 29/32	2 3/4	2.88
207	1 3/16	MTHCL219N◆●□Δ	7/8	3.500	0.531	4	2 1/2	1 31/64	2 3/8	1 7/16	5	1 9/16	4 1/8	3 1/16	1 11/16	1 1/32	3 1/16	3.20
208	1 7/16	MTHCL223N◆●□Δ	1 1/8	3.969	0.688	4 3/16	3 1/4	1 45/64	3 1/4	1 15/16	5 5/8	2 1/16	4 3/4	3 3/16	7/8	1 7/32	3 1/2	5.29
209	1 1/2	MTHCL224N◆●□Δ	1 1/8	3.969	0.688	4 3/16	3 1/4	1 45/64	3 1/4	1 15/16	5 5/8	2 1/16	4 3/4	3 3/8	7/8	1 7/32	3 7/16	4.96
210	1 11/16	MTHCL227N◆●□Δ	1 1/8	3.969	0.688	4 7/16	3 1/4	1 51/64	3 1/4	1 15/16	5 7/8	2 1/16	4 3/4	3 3/4	7/8	1 5/16	3 9/16	5.21
	1 3/4	MTHCL228N◆●□Δ																
211	1 15/16	MTHCL231N◆●□Δ	1 3/8	5.094	1.062	4 7/8	3 3/4	1 57/64	4	2 1/2	6 13/16	2 1/2	5 7/8	4 3/32	1 3/16	1 11/32	4 3/16	8.87
	2	MTHCL232N◆●□Δ																
212	2 3/16	MTHCL235N◆●□Δ	1 3/8	5.094	1.062	5 5/8	4	2 5/32	4	2 1/2	7 9/16	2 1/2	5 7/8	4 9/32	1 3/16	1 19/32	4 11/16	8.79
214	2 7/16	MTHCL239N◆●□Δ◆	1 5/8	5.906	1.062	6 19/32	4 3/4	2 5/16	4 3/8	2 3/4	8 11/16	2 3/4	6 11/16	4 13/16	1 5/16	1 21/32	5 3/8	15.09
	2 1/2	MTHCL240N◆●□Δ◆																
215	2 11/16	MTHCL243N◆●□Δ◆	1 5/8	5.906	1.062	6 27/32	4 3/4	2 23/64	4 3/8	2 3/4	8 15/16	2 3/4	6 11/16	5 1/4	1 5/16	1 7/16	5 1/2	14.87

Additional Notes

- Please call 1-866-REXNORD for availability
- Lubrication fitting tap size, 1/8 in PT
- Lip seals standard
- ◆ Available with E1 viton seals
- Available with free running style seals, add suffix ● FF, □ HFF or Δ MHFF
- Nickel plated housings available through all size codes, add suffix K75

For the Selection Guide, Load Ratings and Speed Limits, see the Link Belt 200 Series Medium Duty Ball Bearings Engineering section on pages 404 - 407.
 Note: Dimensions subject to change. Certified dimensions of ordered material furnished on request.

MTHS200N

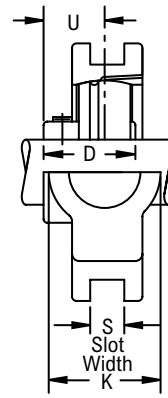
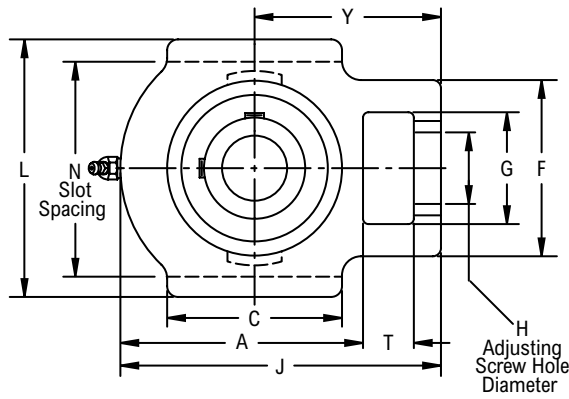
Interchange: WSTUSCM, TUM-TF, MST



Photo Shows a Ball Bearing Take-up Unit

Product Features

- Corrosion-resistant powder coating
- Cast iron housing
- Wide slot design
- Broad range of sealing options
- Spring locking setscrew mount
- Alignable & relubricatable
- See Features and Benefits for additional info on pages 400 - 401.



Bearing Dimensions

Size Code	Shaft Diameter	Part Number	H Adjusting Screw Hole Diameter	N Slot Spacing	S Slot Width	A	C	D	F	G	J	K	L	T	U	Y	Approx. Weight
206	1	MTHS216N●●□Δ	7/8	3.500	0.531	3 3/8	2 1/4	1 11/32	2 3/16	1 7/16	4 1/2	1 9/16	4 1/8	11/16	61/64	2 3/4	2.88
207	1 3/16	MTHS219N●●□Δ	7/8	3.500	0.531	4	2 1/2	1 9/16	2 3/8	1 7/16	5	1 9/16	4 1/8	11/16	1 7/64	3 1/16	3.20
208	1 7/16	MTHS223N●●□Δ	1 1/8	3.969	0.688	4 3/16	3 1/4	1 21/32	3 1/4	1 15/16	5 5/8	2 1/16	4 3/4	7/8	1 11/64	3 1/2	5.29
209	1 1/2	MTHS224N●●□Δ	1 1/8	3.969	0.688	4 3/16	3 1/4	1 49/64	3 1/4	1 15/16	5 5/8	2 1/16	4 3/4	7/8	1 15/64	3 7/16	4.96
210	1 11/16	MTHS227N●●□Δ	1 1/8	3.969	0.688	4 7/16	3 1/4	1 13/16	3 1/4	1 15/16	5 7/8	2 1/16	4 3/4	7/8	1 17/64	3 9/16	5.21
	1 3/4	MTHS228N●●□Δ															
211	1 15/16	MTHS231N●●□Δ	1 3/8	5.094	1.062	4 7/8	3 3/4	1 13/16	4	2 1/2	6 13/16	2 1/2	5 7/8	1 3/16	1 9/32	4 3/16	8.87
	2	MTHS232N●●□Δ															
212	2 3/16	MTHS235N●●□Δ	1 3/8	5.094	1.062	5 5/8	4	1 57/64	4	2 1/2	7 9/16	2 1/2	5 7/8	1 3/16	1 5/16	4 11/16	8.79
	2 1/4	MTHS236N●□◆															
214	2 7/16	MTHS239N●□◆	1 5/8	5.906	1.062	6 19/32	4 3/4	2 15/64	4 3/8	2 3/4	8 11/16	2 3/4	6 11/16	1 5/16	1 7/16	5 3/8	15.09
	2 1/2	MTHS240N●□◆															
215	2 11/16	MTHS243N●□◆	1 5/8	5.906	1.062	6 27/32	4 3/4	2 17/64	4 3/8	2 3/4	8 15/16	2 3/4	6 11/16	1 5/16	1 15/32	5 1/2	14.87

Additional Notes

Please call 1-866-REXNORD for availability
 Lubrication fitting tap size, 1/8 in PT
 Lip seals standard

◆ Available with E1 viton seals for all sizes
 Available with free running style seals, add suffix ● FF, □ HFF or Δ MHFF for all size codes

For the Selection Guide, Load Ratings and Speed Limits, see the Link Belt 200 Series Medium Duty Ball Bearings Engineering section on pages 404 - 407.

Note: Dimensions subject to change. Certified dimensions of ordered material furnished on request.

MCHBS200

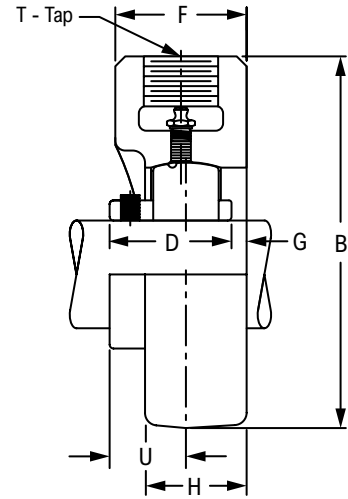
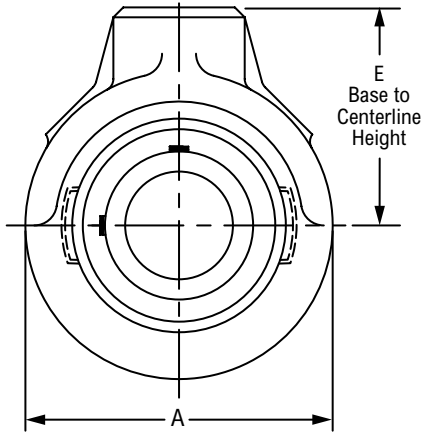
Interchange: SCHB, UCHA200



Photo Shows a Screw Conveyor Hanger Ball Bearing Unit

Product Features

- Corrosion-resistant powder coating
- Cast iron housing
- Broad range of sealing options
- Spring locking setscrew mount
- Alignable & relubricatable
- See Features and Benefits for additional info on pages 400 - 401.



Bearing Dimensions

Size Code	Shaft Diameter	Part Number	E Base to Centerline Height	T		A	B	D	F	G	H	U	Approx. Weight
				Depth	Tap								
206	1	MCHBS216N◆●□△	2 1/2	5/8	3/4-14	3 3/8	4 3/16	1 11/32	1 21/32	7/16	1 7/32	61/64	2.34
207	1 3/16	MCHBS219N◆●□△	2 3/4	5/8	3/4-14	3 7/8	4 11/16	1 9/16	1 21/32	3/8	1 9/32	1 7/64	3.35
208	1 7/16	MCHBS223N◆●□△	2 7/8	5/8	3/4-14	4	4 7/8	1 21/32	1 21/32	11/32	1 11/32	1 11/64	3.44
210	1 11/16	MCHBS227N◆●□△	3 1/4	13/16	1-11 1/2	4 5/8	5 9/16	1 13/16	1 7/8	13/32	1 13/32	1 17/64	5.06
	1 3/4	MCHBS228N◆●□△											4.98
212	2 3/16	MCHBS235N◆●□△	4	1 1/8	1 1/4-11 1/2	5 5/8	6 13/16	1 57/64	2 5/16	37/64	1 5/8	1 5/16	8.44
215	2 11/16	MCHBS243N◆●□△	4 5/8	1 1/4	1 1/2-11 1/2	6 1/2	7 7/8	2 17/64	2 3/4	37/64	1 31/32	1 15/32	12.27
216	2 15/16	MCHBS247N◆●□△	4 7/8	1 1/4	1 1/2-11 1/2	7	8 3/8	2 23/64	2 13/16	35/64	2 1/16	1 1/2	16.00
	3	MCHBS248N◆●□△											15.82
218	3 3/16	MCHBS251N◆●□△	6	1 3/4	2-11 1/2	8 5/16	10 5/32	2 33/64	3 1/2	25/32	2 1/8	1 9/16	25.66
	3 7/16	MCHBS255N◆●□△											24.77
	3 1/2	MCHBS256N◆●□△											24.58

Additional Notes

Please call 1-866-REXNORD for availability
 Lubrication fitting tap size, 1/8 in PT
 Lip seals standard

◆ Available with E1 viton seals for all sizes

Available with free running style seals, add suffix ● FF, □ HFF or △ MHFF for all size codes

For the Selection Guide, Load Ratings and Speed Limits, see the Link Belt 200 Series Medium Duty Ball Bearings Engineering section on pages 404 - 407.

Note: Dimensions subject to change. Certified dimensions of ordered material furnished on request.

MEHBS200

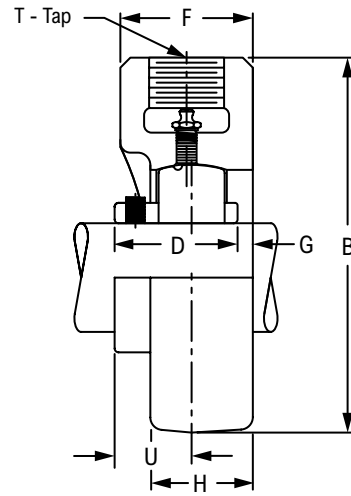
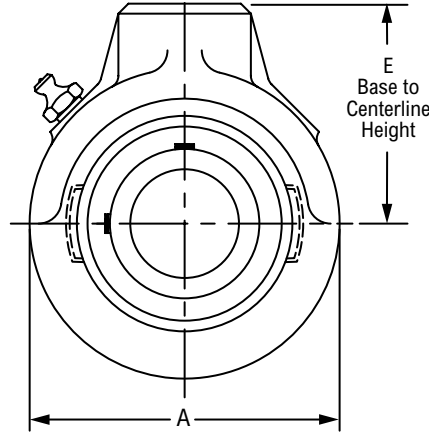
Interchange: SEHB



Photo Shows a Screw Conveyor Hanger Ball Bearing Unit

Product Features

- Corrosion-resistant powder coating
- Cast iron housing
- Broad range of sealing options
- Spring locking setscrew mount
- Alignable & relubricatable
- See Features and Benefits for additional info on pages 400 - 401.



Bearing Dimensions

Size Code	Shaft Diameter	Part Number	E Base to Centerline Height	T		A	B	D	F	G	H	U	Approx. Weight
				Depth	Tap								
206	1	MEHBS216N◆●□△	2 1/2	5/8	3/4-14	3 3/8	4 3/16	1 11/32	1 21/32	7/16	1 7/32	61/64	2.34
207	1 3/16	MEHBS219N◆●□△	2 3/4	5/8	3/4-14	3 7/8	4 11/16	1 9/16	1 21/32	3/8	1 9/32	1 7/64	3.35
208	1 7/16	MEHBS223N◆●□△	2 7/8	5/8	3/4-14	4	4 7/8	1 21/32	1 21/32	11/32	1 11/32	1 11/64	3.44
210	1 11/16	MEHBS227N◆●□△	3 1/4	13/16	1-11 1/2	4 5/8	5 9/16	1 13/16	1 7/8	13/32	1 13/32	1 17/64	5.06
	1 3/4	MEHBS228N◆●□△											4.98
212	2 3/16	MEHBS235N◆●□△	4	1 1/8	1 1/4-11 1/2	5 5/8	6 13/16	1 57/64	2 5/16	37/64	1 5/8	1 5/16	8.44
215	2 11/16	MEHBS243N◆●□△	4 5/8	1 1/4	1 1/2-11 1/2	6 1/2	7 7/8	2 17/64	2 3/4	37/64	1 31/32	1 15/32	12.27
216	2 15/16	MEHBS247N◆●□△	4 7/8	1 1/4	1 1/2-11 1/2	7	8 3/8	2 23/64	2 13/16	35/64	2 1/16	1 1/2	16.00
	3	MEHBS248N◆●□△											15.82
218	3 3/16	MEHBS251N◆●□△	6	1 3/4	2-11 1/2	8 5/16	10 5/32	2 33/64	3 1/2	25/32	2 1/8	1 9/16	25.66
	3 7/16	MEHBS255N◆●□△											24.77
	3 1/2	MEHBS256N◆●□△											24.58

Additional Notes

Please call 1-866-REXNORD for availability
 Lubrication fitting tap size, 1/8 in PT
 Lip seals standard

◆ Available with E1 viton seals for all sizes

Available with free running style seals, add suffix ● FF, □ HFF or △ MHFF for all size codes

For the Selection Guide, Load Ratings and Speed Limits, see the Link Belt 200 Series Medium Duty Ball Bearings Engineering section on pages 404 - 407.

Note: Dimensions subject to change. Certified dimensions of ordered material furnished on request.

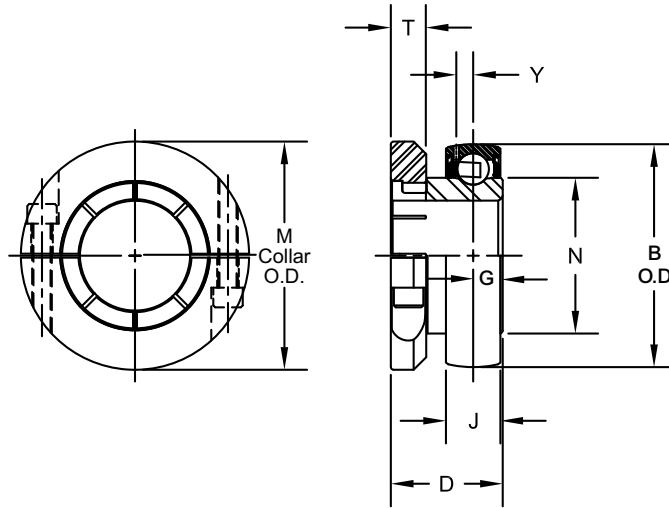
MCLG200NLPA



Photo Shows an Unmounted Ball Bearing Unit

Product Features

- Broad range of sealing options
- Centrik-Lok shaft locking device
- Sealed & relubricatable
- Spherical O.D.
- See Features and Benefits for additional info on pages 400 - 401.



Bearing Dimensions

Size Code	Shaft Diameter	Part Number	B O.D.	J Outer Ring Width	D	G	M Collar O.D.	N	T		Y	Approx. Weight
									Width	Tap		
206	1	MCLG216NLPA◆●□△	2.4409	0.7087	1 5/16	0.3970	2 19/32	1.587	23/64	#10-32	0.202	0.92
207	1 3/16	MCLG219NLPA◆●□△	2.8346	0.7480	1 15/32	0.4420	3 1/16	1.847	7/16	1/4-28	0.227	1.30
208	1 7/16	MCLG223NLPA◆●□△	3.1496	0.8661	1 25/32	0.4740	3 3/16	2.083	7/16	1/4-28	0.263	1.61
209	1 1/2	MCLG224NLPA◆●□△	3.3465	0.8661	1 25/32	0.4770	3 3/8	2.281	7/16	1/4-28	0.256	1.93
210	1 11/16	MCLG227NLPA◆●□△	3.5433	0.8661	1 51/64	0.4860	3 3/4	2.475	9/16	5/16-24	0.256	2.29
	1 3/4	MCLG228NLPA◆●□△										
211	1 15/16	MCLG231NLPA◆●□△	3.9370	0.9843	1 57/64	0.5410	4 3/32	2.749	9/16	5/16-24	0.298	2.58
	2	MCLG232NLPA◆●□△										
212	2 3/16	MCLG235NLPA◆●□△	4.3307	1.0630	2 5/32	0.5820	4 9/32	3.012	9/16	5/16-24	0.330	3.44
	2 1/4	MCLG236NLPA◆●□△										
214	2 7/16	MCLG239NLPA◆●□△	4.9213	1.1545	2 5/16	0.6440	4 13/16	3.433	3/4	3/8-24	0.266	4.67
	2 1/2	MCLG240NLPA◆●□△										
215	2 11/16	MCLG243NLPA◆●□△	5.1181	1.1835	2 23/64	0.6590	5 1/4	3.632	3/4	3/8-24	0.266	4.78
216	2 15/16	MCLG247NLPA◆●□△	5.5118	1.2575	2 25/32	0.6960	5 47/64	3.920	3/4	3/8-24	0.282	5.80
	3	MCLG248NLPA◆●□△										
218	3 3/16	MCLG251NLPA◆●□△	6.2992	1.3945	2 19/32	0.8040	5 47/64	4.396	3/4	3/8-24	0.313	8.71
	3 7/16	MCLG255NLPA◆●□△										8.25
	3 1/2	MCLG256NLPA◆●□△										7.63

Additional Notes

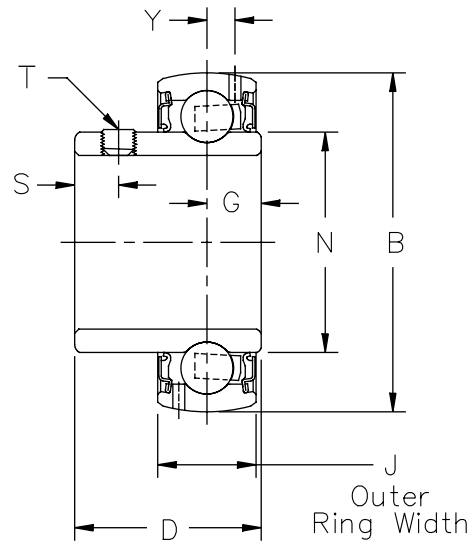
- Please call 1-866-REXNORD for availability
- Bearing O.D. tolerance for size code 206 thru 208, +.0000 in/-0.0005 in (+0.000 mm/-0.013 mm); for size code 209 thru 215, +.0000 in/-0.0006 in (+0.000 mm/-0.015 mm); for all other size codes, +.0000 in/-0.0008 in (+0.000 mm/-0.020 mm)
- Lip seals standard
- ◆ Available with E1 viton seals
- Available with free running style seals, add suffix ● FF, □ HFF or △ MHFF

For the Selection Guide, Load Ratings and Speed Limits, see the Link Belt 200 Series Medium Duty Ball Bearings Engineering section on pages 404 - 407.
 Note: Dimensions subject to change. Certified dimensions of ordered material furnished on request.

MSG200NLPA



Photo Shows an Unmounted Ball Bearing Unit



Product Features

- Broad range of sealing options
- Spring locking setscrew mount
- Sealed & relubricatable
- Spherical O.D.
- See Features and Benefits for additional info on pages 400 - 401.

Bearing Dimensions

Size Code	Shaft Diameter	Part Number	B O.D.	J Outer Ring Width	D	G	N	S	T	Y	Approx. Weight
206	1	MSG216NLPA◆●□△	2.4409	0.7087	1 11/32	0.3920	1.587	0.31	1/4-28	0.202	0.72
207	1 3/16	MSG219NLPA◆●□△	2.8346	0.7480	1 9/16	0.4540	1.847	0.34	5/16-24	0.227	1.03
208	1 7/16	MSG223NLPA◆●□△	3.1496	0.8661	1 21/32	0.4850	2.083	0.34	5/16-24	0.263	1.32
209	1 1/2	MSG224NLPA◆●□△	3.3465	0.8661	1 49/64	0.5320	2.281	0.36	5/16-24	0.256	1.62
210	1 11/16	MSG227NLPA◆●□△	3.5433	0.8661	1 13/16	0.5320	2.475	0.38	3/8-24	0.256	1.82
	1 3/4	MSG228NLPA◆●□△									1.74
211	1 15/16	MSG231NLPA◆●□△	3.9370	0.9843	1 13/16	0.5370	2.749	0.38	3/8-24	0.298	2.36
	2	MSG232NLPA◆●□△									
212	2 3/16	MSG235NLPA◆●□△	4.3307	1.0630	1 57/64	0.5780	3.012	0.38	3/8-24	0.330	2.97
	2 1/4	MSG236NLPA◆●□△									
214	2 7/16	MSG239NLPA●□△◆	4.9213	1.1545	2 15/64	0.8040	3.433	0.37	3/8-24	0.266	4.39
	2 1/2	MSG240NLPA●□△◆									4.25
215	2 11/16	MSG243NLPA●□△◆	5.1181	1.1835	2 17/64	0.8040	3.632	0.37	3/8-24	0.266	4.49
216	2 15/16	MSG247NLPA●□△◆	5.5118	1.2575	2 23/64	0.8630	3.920	0.37	3/8-24	0.282	5.53
	3	MSG248NLPA●□△◆									5.40
218	3 3/16	MSG251NLPA●□△◆	6.2992	1.3945	2 33/64	0.9620	4.396	0.37	3/8-24	0.313	8.23
	3 7/16	MSG255NLPA●□△◆									7.34
	3 1/2	MSG256NLPA●□△◆									7.15

Additional Notes

- Please call 1-866-REXNORD for availability
- Bearing O.D. tolerance for size code 206 thru 208, +.0000 in/-.0005 in (+0.000 mm/-0.013 mm); for size code 209 thru 215, +.0000 in/-.0006 in (+0.000 mm/-0.015 mm); for all other size codes, +.0000 in/-.0008 in (+0.000 mm/-0.020 mm)
- Lip seals standard
- ◆ Available with E1 viton seals for all sizes
- Available with free running style seals, add suffix ● FF, □ HFF or △ MHFF for all size codes

For the Selection Guide, Load Ratings and Speed Limits, see the Link Belt 200 Series Medium Duty Ball Bearings Engineering section on pages 404 - 407.
 Note: Dimensions subject to change. Certified dimensions of ordered material furnished on request.

Ball Bearings Heavy Duty (300 Series) Units: Link-Belt



Contents

	Page
Features and Benefits	424
Nomenclature	425
Engineering	426
Dimensions	
Pillow Blocks	431
Flange Blocks	436
Cartridge Blocks	442
Take-up Blocks	445
Take-up Frames	447
Unmounted Replacement Bearings	448
SHURLOK Installation Tools	452

Industries Served

Aggregates
Air Handling
Forestry
Mining
Steel
Package Handling



300 Series Heavy Duty Ball Bearing Units

300 Series wide inner ring ball bearing units are designed for heavy duty applications requiring high capacity and/or high speed in a compact footprint. Manufactured from quality alloy bearing steel to precision tolerances, these bearings are used extensively on general industrial equipment, high speed fans and blowers and heavier duty power transmission and material handling equipment.

Super-finished Raceways

- Provides a cool running, quiet, high-speed and high-load capacity bearing

Spyglass Optical Strain Sensor (OSS)

- Provides instant feedback for optimal shaft grip
- Eliminates damage to the shaft and bearing because of improper tightness on the mounting.
- Quick installation: Simply tighten collar until the Spyglass shows a back-to-color pattern.

Seal Choice

- Choice of steel-clad molded type H clearance seal or type N double lip seal.

Wide Inner Ring

- Wide inner ring is for greater contact surface between shaft and bearing.

Prelubricated and Relubricatable

Rugged One-piece Housing

Positive Locking System

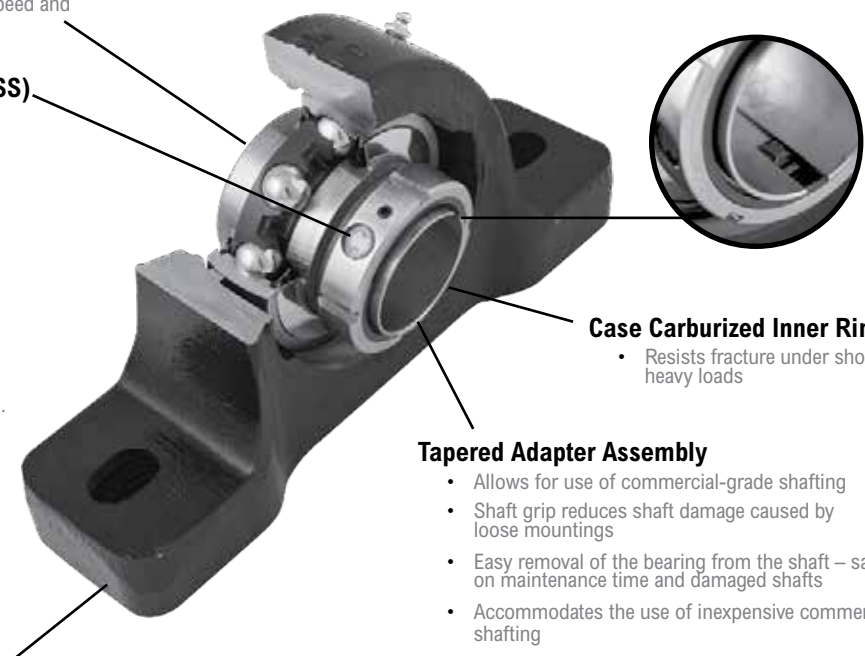
- Minimizes vibration; does not require mounting inspections

Case Carburized Inner Ring

- Resists fracture under shock and heavy loads

Tapered Adapter Assembly

- Allows for use of commercial-grade shafting
- Shaft grip reduces shaft damage caused by loose mountings
- Easy removal of the bearing from the shaft – saves on maintenance time and damaged shafts
- Accommodates the use of inexpensive commercial grade shafting



Heavy Duty Ball Bearings

Heavy series precision alignable ball bearings of deep groove construction with larger balls and thicker rings for high capacity and longer life. The extra inner ring width furnishes ultimate shaft and load support and concentricity for high speed precision application.

The spring locking collar design provides a secure grip of the wide inner ring bearing to the shaft. The two setscrews extend through the inner ring of the bearing and lock firmly into the shaft. Tightening the two setscrews produces elastic strain in the spring locking collar resulting in a continuous pressure on the shaft.

The eccentric cam locking collar design provides a secure grip of the wide inner ring bearing to the shaft and further tightens with bearing rotation. The adapter mount design provides better concentricity and shaft control, increasing service life. The adapter mount allows for easy installation/removal and enables the use of commercial grade shafting.

Furnished with anti-rotation pin in the outer ring to prevent the outer ring from spinning in the bearing housing.

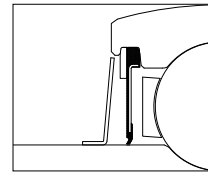
One-piece Cast Iron Housings

Compact, one-piece cast iron housings provide strength with minimum size and weight, and excellent rigidity. All housings are designed with standard mounting dimensions and have finished mounting surfaces for proper installation stability. Pillow blocks have slotted bolt holes with ample space provided for drilling dowel pin holes and are also available with high backing dimensions. Flanged and flanged cartridge units have drilled mounting holes. Take-up units have machined slots for accurate adjustment.

Bearing Mounted Molded Rubber Seal

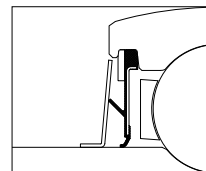
Type H Seal

These molded rubber seals effectively retain lubricant and protect against contamination. An external seal guard enhances protection against contamination and protects the molded rubber seal. A snap ring locates and retains the molded rubber seal in the outer ring to ensure proper operation. This is an excellent non-contact seal for grease lubrication.



Type N Seal

These molded rubber double lip seals have two full land riding lips that effectively retain lubricant and protect against contamination. These seals ride on a precision ground surface of the bearing inner ring for smooth operation and tightness.



300 Series Nomenclature

Symbol	Description	P	E	-U	3	K	27	J	N	C	17H	4
C	Cartridge unit											
F	Flanged unit, 4-bolt square											
FC	Flanged cartridge unit, 4-bolt round											
P	Pillow block, standard backing											
PL	Pillow block, low backing											
P2	Pillow block, high backing											
T	Take-up, slotted guides											
E	Expansion unit											
A	Bearing sealed unit, SHURLOK adapter, relubricatable											
U	Bearing sealed unit, spring locking, relubricatable											
Y	Bearing sealed unit, eccentric cam locking collar, relubricatable											
3	300 Series ball bearing designation											
K	Adapter mounted											
27	Shaft size in sixteenths of an inch											
J	Steel retainers											
None	Steel clad clearance seal											
N	Molded double lip seals											
C	Closed end unit											
17H	Grease designation											
4	Clearance, other than standard											

Replacement Ball Bearing Nomenclature

		UG	3	K	47	N	L
AG	Wide inner ring, bearing seals, SHURLOK adapter						
UG	Wide inner ring, bearing seals, spring locking collar						
YG	Wide inner ring, bearing seals, eccentric cam locking collar						
3	300 Series ball bearing designation						
K	Adapter mounted						
47	Shaft size in sixteenths of an inch						
None	Steel clad clearance seal						
N	Molded double lip seals						
L1	Bearing without collar						
L	Bearing with collar & setscrews						

300 Series Ball Bearings Selection Guide

To select a bearing, determine the applied radial load, the applied thrust load, the desired Rating Life, and applicable operating conditions. The procedure shown here will aid in selecting a bearing to meet an L_{10} design life. The formulas for calculating life expectancy should be used to determine the Rating Life L_{10} for the bearing selected.

The selection procedures and rating formulas shown here are in agreement with The American Bearing Manufacturers Association Standards and ANSI/ABMA STD 9-1990. Ratings are based on fatigue life. The Rating Life L_{10} or fatigue life at 90% reliability is the usual basis for bearing selection. To assure a satisfactory bearing application, fitting practice, mounting, lubrication, sealing, static rating, housing strength, operating conditions and maintenance must be considered.

Steps for Selection

Step 1

Determine an appropriate L_{10} design life.

Type of service	Operating time, hours per year	Design life, years	L_{10} design life, hours
Light seasonal usage	500 to 750	3-5	3,000
Heavy seasonal usage	1,400 to 1,600	4-6	8,000
Industrial—8 hour shift	2,000	10	20,000
Industrial—16 hour shift	4,000	10	40,000
Industrial—Continuous	8,700	10	80,000 to 100,000

Step 2

Determine a required $\left(\frac{C}{P}\right)$ from Table 1.

Step 3

Calculate the required C and select a ball bearing.

a For radial load only:

$$P = F_r$$

$$\text{required } C = \left(\frac{C}{P}\right) P \text{ using } \left(\frac{C}{P}\right) \text{ from Step 2}$$

Select a ball bearing from Table 3 with a basic load rating C equal to or greater than the required C.

b For combined radial and thrust loads when $\frac{F_a}{F_r}$ is 0.19 or less:

$$P = F_r$$

$$\text{required } C = \left(\frac{C}{P}\right) P \text{ using } \left(\frac{C}{P}\right) \text{ from Step 2}$$

Select a ball bearing from Table 3 with a basic load rating C equal to or greater than the required C.

Step 3 (continued)

c For combined radial and thrust loads when $\frac{F_a}{F_r}$ is greater than 0.19, use the following trial method:

$$\text{Maximum } P = .56F_r + 2.30F_a$$

$$\text{Maximum required } C = \left(\frac{C}{P}\right) P \text{ using } \left(\frac{C}{P}\right) \text{ from Step 2}$$

Select a trial ball bearing with a basic load rating C from Table 3 approximately equal to the maximum required C.

With this trial bearing calculate: $\frac{F_a}{Nd^2}$

Determine X and Y from Table 2.

Calculate P for the trial bearing.

$$P = XF_r + YF_a$$

$$\text{required } C = \left(\frac{C}{P}\right) P \text{ for the trial bearing using } \left(\frac{C}{P}\right) \text{ from Step 2}$$

Consult Table 3, basic load rating. If a smaller bearing meets or nearly meets the required C, its life expectancy can be calculated.

Note: If the load P is greater than .25C, consult Rexnord Bearing Products.

Selection

Symbols for formulas:

C = basic load rating, pounds (or newtons)
 C₀ = static load rating, pounds (or newtons)
 e = a reference value
 F_a = thrust load, pounds (or newtons)
 F_r = radial load, pounds (or newtons)
 L₁₀ = rating life, hours

n = speed, revolutions per minute
 P = equivalent radial load, pounds (or newtons)
 X = radial factor
 Y = thrust factor

Table 1 • Relation of L₁₀ life and speed to $\left(\frac{C}{P}\right)$

Bearing life, hours L ₁₀	$\left(\frac{C}{P}\right)$ ratio									
	Speed, n									
	50	100	200	300	400	500	600	700	800	
3000	2.08	2.62	3.30	3.77	4.15	4.47	4.75	5.01	5.23	
4000	2.29	2.88	3.63	4.15	4.57	4.92	5.23	5.51	5.76	
5000	2.46	3.10	3.91	4.47	4.92	5.30	5.64	5.93	6.20	
6000	2.62	3.30	4.15	4.75	5.23	5.64	5.99	6.30	6.59	
8000	2.88	3.63	4.57	5.23	5.76	6.20	6.59	6.94	7.25	
10000	3.10	3.91	4.92	5.64	6.20	6.68	7.10	7.47	7.81	
12000	3.30	4.15	5.23	5.99	6.59	7.10	7.54	7.94	8.30	
14000	3.47	4.37	5.51	6.30	6.94	7.47	7.94	8.36	8.74	
16000	3.63	4.57	5.76	6.59	7.25	7.81	8.30	8.74	9.14	
18000	3.77	4.75	5.99	6.86	7.54	8.13	8.63	9.09	9.50	
20000	3.91	4.92	6.20	7.10	7.81	8.42	8.94	9.41	9.84	
25000	4.21	5.30	6.68	7.65	8.42	9.07	9.63	10.1	10.6	
30000	4.47	5.64	7.10	8.13	8.94	9.63	10.2	10.8	11.3	
35000	4.71	5.93	7.47	8.55	9.41	10.1	10.8	11.3	11.9	
40000	4.92	6.20	7.81	8.94	9.84	10.6	11.3	11.9	12.4	
45000	5.12	6.45	8.13	9.30	10.2	11.0	11.7	12.3	12.9	
50000	5.30	6.68	8.42	9.63	10.6	11.4	12.1	12.8	13.4	
60000	5.64	7.10	8.94	10.2	11.3	12.1	12.9	13.6	14.2	
70000	5.93	7.47	9.41	10.8	11.9	12.8	13.6	14.3	14.9	
80000	6.20	7.81	9.84	11.3	12.4	13.4	14.2	14.9	15.6	
90000	6.45	8.13	10.2	11.7	12.9	13.9	14.8	15.5	16.2	
100000	6.68	8.42	10.6	12.1	13.4	14.4	15.3	16.1	16.8	
150000	7.65	9.63	12.1	13.9	15.3	16.5	17.5	18.4	19.3	
200000	8.42	10.6	13.4	15.3	16.8	18.1	19.3	20.3	21.2	

	Speed, n									
	900	1000	1200	1500	1800	2400	3600	6000	10000	
3000	5.44	5.64	5.99	6.45	6.86	7.54	8.63	10.2	12.1	
4000	5.99	6.20	6.59	7.10	7.54	8.30	9.50	11.3	13.4	
5000	6.45	6.68	7.10	7.65	8.13	8.94	10.2	12.1	14.4	
6000	6.86	7.10	7.54	8.13	8.63	9.50	10.9	12.9	15.3	
8000	7.54	7.81	8.30	8.94	9.50	10.5	12.0	14.2	16.8	
10000	8.13	8.42	8.94	9.63	10.2	11.3	12.9	15.3	18.1	
12000	8.63	8.94	9.50	10.2	10.9	12.0	13.7	16.2	19.3	
14000	9.09	9.41	10.0	10.8	11.4	12.6	14.4	17.1	20.3	
16000	9.50	9.84	10.5	11.3	12.0	13.2	15.1	17.9	21.2	
18000	9.88	10.2	10.9	11.7	12.4	13.7	15.7	18.6	22.0	
20000	10.2	10.6	11.3	12.1	12.9	14.2	16.2	19.3	22.8	
25000	11.0	11.4	12.1	13.1	13.9	15.3	17.5	20.7	24.6	
30000	11.7	12.1	12.9	13.9	14.8	16.2	18.6	22.0	26.1	
35000	12.3	12.8	13.6	14.6	15.5	17.1	19.6	23.2	27.5	
40000	12.9	13.4	14.2	15.3	16.2	17.9	20.5	24.3	28.7	
45000	13.4	13.9	14.8	15.9	16.9	18.6	21.3	25.2	29.9	
50000	13.9	14.4	15.3	16.5	17.5	19.3	22.0	26.1	31.0	
60000	14.8	15.3	16.2	17.5	18.6	20.5	23.4	27.8	32.9	
70000	15.5	16.1	17.1	18.4	19.6	21.5	24.6	29.2	34.6	
80000	16.2	16.8	17.9	19.3	20.5	22.5	25.8	30.5	36.2	
90000	16.9	17.5	18.6	20.0	21.3	23.4	26.8	31.8	37.7	
100000	17.5	18.1	19.3	20.7	22.0	24.3	27.8	32.9	39.0	
150000	20.0	20.7	22.0	23.7	25.2	27.8	31.8	37.7	44.6	
200000	22.0	22.8	24.3	26.1	27.8	30.5	35.0	41.4	49.1	

Basic formula

$$\left(\frac{C}{P}\right) = \left(\frac{L_{10} \times n \times 60}{1,000,000}\right)^{1/3}$$

$$L_{10} = \frac{\left(\frac{C}{P}\right)^3 \times 1,000,000}{n \times 60}$$

Life Expectancy

To calculate the Rating Life L₁₀ of any selected or trial bearing:

Step 1 Determine the equivalent radial load P.

a For radial load only:
 P = F_r

b For combined radial and thrust load:
 P = X F_r + Y F_a using X and Y from Table 2 below.

Step 2 Calculate the ratio of basic load rating C to the equivalent radial load.

$$\left(\frac{C}{P}\right)$$

Step 3 Approximate the bearing life from Table 1.

Table 2 • X and Y factors for ball bearings

F _a Nd ²	e	F _a F _r ≤ e		F _a F _r > e	
		X	Y	X	Y
25	.19	1.0	0	.56	2.30
37.5	.21	1.0	0	.56	2.15
50	.22	1.0	0	.56	1.99
75	.24	1.0	0	.56	1.85
100	.26	1.0	0	.56	1.71
125	.27	1.0	0	.56	1.63
150	.28	1.0	0	.56	1.56
200	.30	1.0	0	.56	1.45
300	.34	1.0	0	.56	1.31
500	.38	1.0	0	.56	1.15
750	.42	1.0	0	.56	1.04
1000	.44	1.0	0	.56	1.00

For values between those in the table linear interpolation can be used.

Life Adjustment

The Rating Life, L₁₀, may be modified for some applications in accordance with the formula

$$L'n = a_1 a_2 a_3 L_{10}$$

where L'n = Adjusted life for (100-n) % reliability,

a₁ = Life adjustment factor for reliability

a₂ = Life adjustment factor for material and processing

a₃ = Life adjustment factor for operating conditions.

For most normal applications, all factors will be taken as 1, and the Rating Life used as the selection basis or life estimate. In addition, as long as standard catalog bearings are used, a₂ will be normally set equal to one. The factor a₃ covers such things as lubrication, misalignment, and temperature. Some conditions that could yield a₃ significantly different than unity include speeds less than 20000 DN or greater than 200000 DN, temperatures below -40°F (-40°C) or above 275°F (135°C). For other possible conditions, as well as additional information on life adjustment factors, consult Rexnord Bearing Products.

Table 3 • Load Ratings, Speed Limits and Ball Data

Size Code	C Basic load rating		Co Static load rating		Approximate speed limit RPM*		d Ball Diameter inches	N Number of balls	ND ²
	Pounds	Newtons	Pounds	Newtons	Std. Seals	N Seals			
312	3614	16050	1770	7890	10950	...	3/8	7	0.98
316	4810	21400	2450	10900	9350	...	7/16	7	1.34
319	6320	28150	3530	15700	8300	6100	31/64	8	1.88
323	7490	33300	4290	19100	7550	5400	17/32	8	2.26
324	9126	40600	5390	24000	7200	...	19/32	8	2.82
328	11870	52950	7110	31600	6200	4300	11/16	8	3.78
331	13900	61800	8500	37800	5600	3900	3/4	8	4.50
335	16070	71480	1000	11600	4950	3550	13/16	8	5.28
339	18390	81550	11700	51900	4450	3250	7/8	8	6.12
344	23420	104150	15300	68100	3950	2800	1	8	8.00
347	26140	113450	17300	77100	3700	2650	1-1/16	8	9.03
351	28990	122980	19500	86600	3400	...	1-1/8	8	10.10
356	35070	142700	24100	107200	3100	...	1-1/4	8	12.50
363	45000	173100	31600	140500	2750	...	1-7/16	8	16.50

If the load P is greater than 25% of the C rating, consult Rexnord Bearing Division.

For U300 and Y300 Series reduce C Basic Load Rating by 23%

*Based on grease lubrication and moderate load.

Table 4 • Radial Load Ratings In Pounds At Various RPM For Appropriate L₁₀ Life Hours

Bearing Size Number		Radial Load Ratings, Pounds																	
Size Code	L ₁₀ Minimum life, hours	Speed, RPM																	
		50	100	200	300	400	500	600	700	800	900	1000	1200	1500	1800	2000	2500	3000	3500
312	8000	1253	994	789	689	626	582	547	520	497	478	462	434	403	379	366	340	320	304
	20000	923	733	582	508	462	428	403	383	366	352	340	320	297	280	270	251	236	224
	40000	733	582	462	403	366	340	320	304	291	280	270	254	236	222	214	199	187	178
	100000	540	428	340	297	270	251	236	224	214	206	199	187	174	163	158	147	138	131
316	8000	1668	1324	1050	918	834	774	728	692	662	636	614	578	537	505	488	453	426	405
	20000	1229	975	774	676	614	570	537	510	488	469	453	426	395	372	359	334	314	298
	40000	975	774	614	537	488	453	426	405	387	372	359	338	314	295	285	265	249	237
	100000	719	570	453	395	359	334	314	298	285	274	265	249	231	218	210	195	184	174
319	8000	2195	1742	1383	1208	1097	1019	959	911	871	837	809	761	706	665	642	596	561	533
	20000	1617	1284	1019	890	809	751	706	671	642	617	596	561	520	490	473	439	413	392
	40000	1284	1019	809	706	642	596	561	533	509	490	473	445	413	389	375	348	328	311
	100000	946	751	596	520	473	439	413	392	375	361	348	328	304	286	277	257	242	229
323	8000	2596	2060	1635	1429	1298	1205	1134	1077	1030	991	956	900	835	786	759	705	663	630
	20000	1913	1518	1205	1053	956	888	835	794	759	730	705	663	616	579	559	519	489	464
	40000	1518	1205	956	835	759	705	663	630	602	579	559	526	489	460	444	412	388	368
	100000	1119	888	705	616	559	519	489	464	444	427	412	388	360	339	327	304	286	271
324	8000	3164	2511	1993	1741	1582	1469	1382	1313	1256	1207	1166	1097	1018	958	925	859	808	768
	20000	2331	1850	1469	1283	1166	1082	1018	967	925	889	859	808	750	706	682	633	595	566
	40000	1850	1469	1166	1018	925	859	808	768	734	706	682	641	595	560	541	502	473	449
	100000	1363	1082	859	750	682	633	595	566	541	520	502	473	439	413	399	370	348	331
328	8000	4128	3277	2601	2272	2064	1916	1803	1713	1638	1575	1521	1431	1329	1250	1207	1121	1055	1002
	20000	3042	2414	1916	1674	1521	1412	1329	1262	1207	1161	1121	1055	979	921	889	826	777	738
	40000	2414	1916	1521	1329	1207	1121	1055	1002	958	921	889	837	777	731	706	655	617	586
	100000	1779	1412	1121	979	889	826	777	738	706	679	655	617	572	539	520	483	454	432
331	8000	4822	3827	3038	2654	2411	2238	2106	2001	1914	1840	1777	1672	1552	1460	1410	1309	1232	1170
	20000	3553	2820	2238	1955	1777	1649	1552	1474	1410	1356	1309	1232	1144	1076	1039	964	908	862
	40000	2820	2238	1777	1552	1410	1309	1232	1170	1119	1076	1039	978	908	854	825	765	720	684
	100000	2078	1649	1309	1144	1039	964	908	862	825	793	765	720	669	629	608	564	531	504
335	8000	5588	4436	3521	3075	2794	2594	2441	2319	2218	2132	2059	1937	1799	1692	1634	1517	1428	1356
	20000	4118	3268	2594	2266	2059	1911	1799	1708	1634	1571	1517	1428	1325	1247	1204	1118	1052	999
	40000	3268	2594	2059	1799	1634	1517	1428	1356	1297	1247	1204	1133	1052	990	956	887	835	793
	100000	2408	1911	1517	1325	1204	1118	1052	999	956	919	887	835	775	729	704	654	615	584
339	8000	6355	5044	4003	3497	3177	2950	2776	2637	2522	2425	2341	2203	2045	1925	1858	1725	1623	
	20000	4682	3716	2950	2577	2341	2173	2045	1943	1858	1787	1725	1623	1507	1418	1369	1271	1196	
	40000	3716	2950	2341	2045	1858	1725	1623	1542	1475	1418	1369	1288	1196	1125	1087	1009	949	
	100000	2738	2173	1725	1507	1369	1271	1196	1136	1087	1045	1009	949	881	829	801	743	699	
344	8000	8112	6439	5110	4464	4056	3765	3543	3366	3219	3095	2989	2812	2611	2457	2372	2202		
	20000	5977	4744	3765	3289	2989	2774	2611	2480	2372	2281	2202	2072	1924	1810	1748	1622		
	40000	4744	3765	2989	2611	2372	2202	2072	1968	1883	1810	1748	1645	1527	1437	1387	1288		
	100000	3495	2774	2202	1924	1748	1622	1527	1450	1387	1334	1288	1212	1125	1059	1022	949		
347	8000	8924	7083	5621	4911	4462	4142	3898	3703	3541	3405	3287	3094	2872	2703	2609	2422		
	20000	6575	5219	4142	3618	3287	3052	2872	2728	2609	2509	2422	2279	2116	1991	1923	1785		
	40000	5219	4142	3287	2872	2609	2422	2279	2165	2071	1991	1923	1809	1679	1580	1526	1417		
	100000	3845	3052	2422	2116	1923	1785	1679	1595	1526	1467	1417	1333	1237	1164	1124	1044		
351	8000	9509	7548	5991	5233	4755	4414	4154	3946	3774	3629	3503	3297	3060	2880	2781	2581		
	20000	7007	5561	4414	3856	3503	3252	3060	2907	2781	2674	2581	2429	2255	2122	2049	1902		
	40000	5561	4414	3503	3060	2781	2581	2429	2307	2207	2122	2049	1928	1790	1684	1626	1510		
	100000	4097	3252	2581	2255	2049	1902	1790	1700	1626	1563	1510	1421	1319	1241	1198	1112		
356	8000	11087	8800	6984	6101	5543	5146	4843	4600	4400	4230	4084	3844	3568	3358	3242			
	20000	8169	6484	5146	4495	4084	3792	3568	3389	3242	3117	3009	2832	2629	2474	2389			
	40000	6484	5146	4084	3568	3242	3009	2832	2690	2573	2474	2389	2248	2087	1964	1896			
	100000	4777	3792	3009	2629	2389	2217	2087	1982	1896	1823	1760	1656	1537	1447	1397			
363	8000	13521	10731	8517	7441	6760	6276	5906	5610	5366	5159	4981	4687	4351	4095	3953			
	20000	9962	7907	6276	5482	4981	4624	4351	4133	3953	3801	3670	3454	3206	3017	2913			
	40000	7907	6276	4981	4351	3953	3670	3454	3281	3138	3017	2913	2741	2545	2395	2312			
	100000	5826	4624	3670	3206	2913	2704	2545	2417	2312	2223	2146	2020	1875	1764	1703			

If the load P is greater than 25% of the C rating, consult Rexnord Bearing Division.

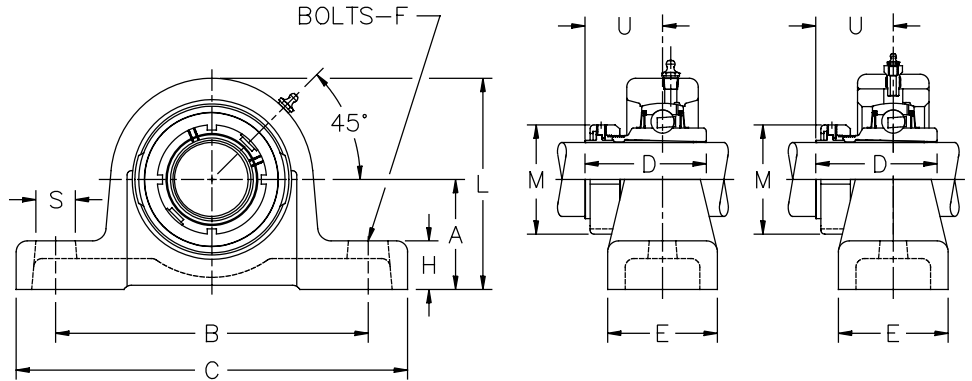
For U300 and Y300 Series reduce C Basic Load Rating by 23%

PA300, PEA300



Product Features

- Spyglass Optical Strain Sensor (OSS) Technology
- Positive locking system
- Tapered adapter sleeve
- Corrosion-resistant powder coating
- Cast iron housing
- Fixed or Expansion - Up to 3/8 in expansion
- Alignable & relubricatable
- See Features and Benefits for additional info on page 424.



Bearing Dimensions

Size Code	Shaft Diameter	Expansion		Fixed		A Base to Centerline Height	B Distance Between Bolt Holes	C	D	E	F Bolts	H	M	S	U	Total Axial Expansion	Approx. Weight
		Part Number	L	Part Number	L												
319	1 3/16	PEA319	4 1/4	PA319	4 1/16	2 1/8	6 7/16	8 1/4	2 3/4	2 1/4	1/2	15/16	2 5/32	1 1/16	1.98	3/16	5.50
323	1 7/16	PEA323	4 11/16	PA323	4 1/2	2 3/8	7 3/8	9 1/4	2 47/64	2 3/8	5/8	1	2 3/8	1 1/8	1.91	3/16	7.77
328	1 11/16	PEA327	5 5/8	PA327	5 1/2	2 7/8	8 1/4	10 1/4	3 1/8	3	5/8	1 5/16	2 41/64	1 1/8	2.22	3/16	13.35
331	1 15/16	PEA331	6 7/32	PA331	6	3 1/8	8 7/8	11 1/8	3 7/32	3 1/8	5/8	1 3/8	2 55/64	1 1/8	2.13	1/4	16.00
335	2 3/16	PEA335	6 13/16	PA335	6 5/8	3 1/2	10 1/4	12 5/8	3 23/64	3 3/8	3/4	1 1/2	3 15/64	1 1/4	2.14	9/32	24.00
339	2 7/16	PEA339	7 3/16	PA339	7 1/8	3 5/8	11 1/4	13 3/4	3 27/32	3 1/2	3/4	1 5/8	3 19/32	1 3/8	2.39	9/32	27.00
344	2 11/16	PEA343	7 15/16	PA343	7 3/4	4	11 13/16	14 5/8	4 1/4	3 3/4	7/8	1 5/8	4 3/32	1 5/8	2.69	7/32	36.00
	2 3/4	PEA344		PA344													
347	2 15/16	PEA347	8 3/8	PA347	8 3/8	4 1/4	12	15 1/8	4 17/32	4	7/8	1 3/4	4 3/32	1 5/8	2.80	7/32	44.00
351	3 3/16	PEA351	9	PA351	9	4 9/16	12 1/4	15 3/8	5 1/2	4 5/16	7/8	1 15/16	4 61/64	1 5/8	3.69	11/32	55.00
356	3 7/16	PEA355	10 1/16	PA355	9 7/8	5 1/8	12 7/8	16 1/8	5 23/64	5	1	2 1/4	4 61/64	1 5/8	3.33	11/32	68.00
363	3 15/16	PEA363	11 1/16	PA363	11 1/16	5 11/16	14 1/2	17 5/16	5 29/32	5	1	2 9/16	5 43/64	1 1/2	3.97	11/32	98.00

Additional Notes

- Please call 1-866-REXNORD for availability
- Lubrication fitting tap size: for expansion units with shaft sizes 2 7/16 in and below, 1/4 in-28 UNF; for other expansion units and all fixed units, 1/8 in PT
- Base to centerline tolerance, +0.000 in/-0.010 in (+0.00 mm/-0.25 mm)
- 1 3/16 in thru 2 15/16 in shaft sizes also available with dual contact lip seals, add suffix N
- For the Selection Guide, Load Ratings and Speed Limits, see the Link-Belt 300 Series Heavy Duty Ball Bearings Engineering section on pages 426 - 429.
- Note: Dimensions subject to change. Certified dimensions of ordered material furnished on request.

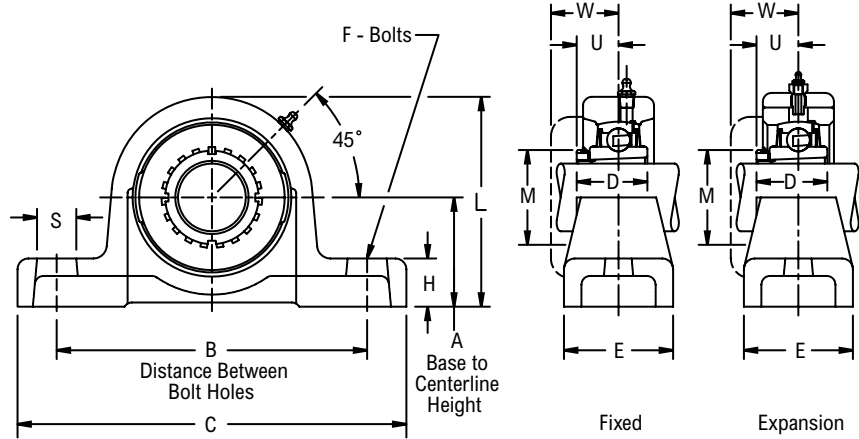
PU3K00, PEU3K00



Photo Shows a 2-Bolt Ball Bearing Pillow Block Unit

Product Features

- Corrosion-resistant powder coating
- Cast iron housing
- Enhanced life mounting style
- Fixed or Expansion - Up to 11/32 in expansion
- Alignable & relubricatable
- See Features and Benefits for additional info on page 424.



Bearing Dimensions

Size Code	Shaft Diameter	Expansion		Fixed		A Base to Centerline Height	B Distance Between Bolt Holes	C	D	E	F Bolts	H	M	S	U	W	Total Axial Expansion	Approx. Weight
		Part Number	L	Part Number	L													
331	1 11/16	PEU3K27	6 7/32	PU3K27	6	3 1/8	8 7/8	11 1/8	2 17/32	3 1/8	5/8	1 3/8	2 11/16	1 1/8	1 35/64	1 27/32	1/4	17.00
335	1 15/16	PEU3K31	6 13/16	PU3K31	6 5/8	3 1/2	10 1/4	12 5/8	2 19/32	3 3/8	3/4	1 1/2	2 31/32	1 1/4	1 43/64	1 31/32	9/32	23.00
344	2 3/16	PEU3K35	7 15/16	PU3K35	7 3/4	4	11 13/16	14 5/8	3 1/32	3 3/4	7/8	1 5/8	3 3/8	1 5/8	1 27/32	2 3/16	7/32	35.00
347	2 7/16	PEU3K39	8 3/8	PU3K39	8 3/8	4 1/4	12	15 1/8	3 3/16	4	7/8	1 3/4	3 7/8	1 5/8	1 15/16	2 7/16	7/32	41.00
351	2 11/16	PEU3K43	9	PU3K43	9	4 9/16	12 1/4	15 3/8	3 5/16	4 5/16	7/8	1 15/16	4 5/32	1 5/8	2 1/4	2 5/8	11/32	50.00
356	2 15/16	PEU3K47	10 1/16	PU3K47	9 7/8	5 1/8	12 7/8	16 1/8	3 17/32	5	1	2 1/4	4 13/32	1 5/8	2 3/8	2 3/4	11/32	60.00
363	3 7/16	PEU3K55	11 1/16	PU3K55	11 1/16	5 11/16	14 1/2	17 5/16	3 31/32	5	1	2 9/16	5 3/16	1 1/2	2 29/32	3 9/32	11/32	82.00

Additional Notes

- Please call 1-866-REXNORD for availability
- Lubrication fitting tap size: for expansion units with shaft sizes 1 15/16 in and below, 1/4 in-28 UNF; for other expansion units and all fixed units, 1/8 in PT
- Base to centerline tolerance, +.000 in/-0.010 in (+0.00 mm/-0.25 mm)
- 1 11/16 in thru 2 7/16 in shaft sizes also available with dual contact lip seals, add suffix N
- For the Selection Guide, Load Ratings and Speed Limits, see the Link-Belt 300 Series Heavy Duty Ball Bearings Engineering section on pages 426 - 429.

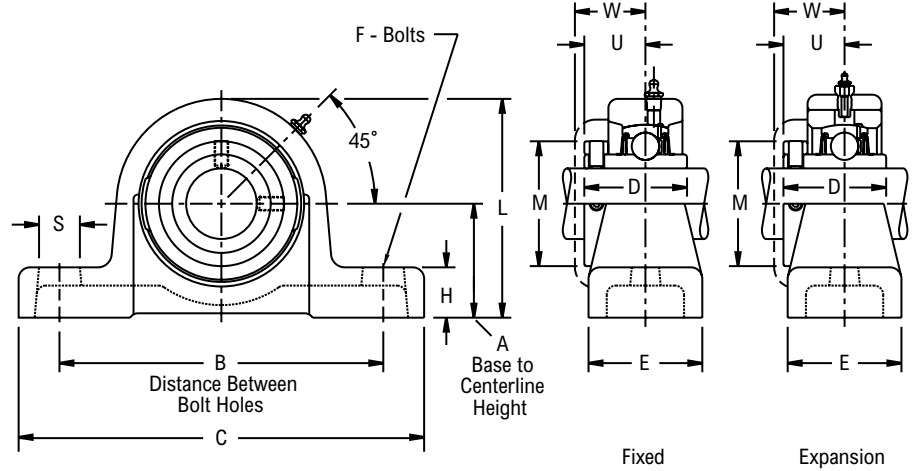
Note: Dimensions subject to change. Certified dimensions of ordered material furnished on request.



Photo Shows a 2-Bolt Ball Bearing Pillow Block Unit

Product Features

- Corrosion-resistant powder coating
- Cast iron housing
- Spring locking setscrew mount
- Fixed or Expansion - Up to 11/32 in expansion
- Alignable & relubricatable
- See Features and Benefits for additional info on page 424.



Bearing Dimensions

Size Code	Shaft Diameter	Expansion		Fixed		A Base to Centerline Height	B Distance Between Bolt Holes	C	D	E	F Bolts	H	M	S	U	W	Total Axial Expansion	Approx. Weight
		Part Number	L	Part Number	L													
312	3/4	PEU312	3 3/16	PU312	3 1/16	1 5/8	5	6 1/2	1 15/32	1 3/4	1/2	13/16	1 5/8	7/8	27/32	1 3/64	3/16	3.00
	7/8	PEU314		PU314														
316	15/16	PEU315	3 23/32	PU315	3 9/16	1 7/8	5 1/2	7	1 43/64	2	1/2	7/8	2	7/8	63/64	1 15/64	3/16	4.00
	1	PEU316		PU316														
319	1 1/8	PEU318	4 1/4	PU318	4 1/16	2 1/8	6 7/16	8 1/4	1 59/64	2 1/4	1/2	15/16	2 5/16	1 1/16	1 9/64	1 13/32	3/16	5.90
	1 3/16	PEU319		PU319														
323	1 1/4	PEU320		PU320														7.50
	1 3/8	PEU322	4 11/16	PU322	4 1/2	2 3/8	7 3/8	9 1/4	2 3/32	2 3/8	5/8	1	2 9/16	1 1/8	1 1/4	1 1/2	3/16	
	1 7/16	PEU323		PU323														
324	1 1/2	PEU324	5 7/32	PU324	5	2 5/8	8	10 1/8	2 5/16	2 5/8	5/8	1 1/4	3 1/16	1 1/4	1 25/64	1 39/64	3/16	11.50
	1 5/8	PEU326		PU326														
328	1 11/16	PEU327	5 5/8	PU327	5 1/2	2 7/8	8 1/4	10 1/4	2 19/32	3	5/8	1 5/16	3 1/4	1 1/8	1 35/64	1 27/32	3/16	13.00
	1 3/4	PEU328		PU328														
331	1 15/16	PEU331	6 7/32	PU331	6	3 1/8	8 7/8	11 1/8	2 13/16	3 1/8	5/8	1 3/8	3 7/16	1 1/8	1 43/64	1 31/32	1/4	17.20
	2	PEU332		PU332														
335	2 1/8	PEU334	6 13/16	PU334	6 5/8	3 1/2	10 1/4	12 5/8	3 1/16	3 3/8	3/4	1 1/2	3 15/16	1 1/4	1 27/32	2 3/16	9/32	21.50
	2 3/16	PEU335		PU335														
339	2 1/4	PEU336	7 3/16	PU336	7 1/8	3 5/8	11 1/4	13 3/4	3 5/16	3 1/2	3/4	1 5/8	4 3/16	1 3/8	1 15/16	2 7/16	9/32	27.50
	2 7/16	PEU339		PU339														
344	2 11/16	PEU343	7 15/16	PU343	7 3/4	4	11 13/16	14 5/8	3 13/16	3 3/4	7/8	1 5/8	4 3/4	1 5/8	2 1/4	2 5/8	7/32	39.00
	2 3/4	PEU344		PU344														
347	2 15/16	PEU347	8 3/8	PU347	8 3/8	4 1/4	12	15 1/8	4 3/32	4	7/8	1 3/4	4 15/16	1 5/8	2 3/8	2 3/4	7/32	44.50
351	3	PEU348	9	PU348	9	4 9/16	12 1/4	15 3/8	4 13/32	4 5/16	7/8	1 15/16	5 11/16	1 5/8	2 19/32	3	11/32	53.00
	3 3/16	PEU351		PU351														
356	3 7/16	PEU355	10 1/16	PU355	9 7/8	5 1/8	12 7/8	16 1/8	4 15/16	5	1	2 1/4	6	1 5/8	2 29/32	3 9/32	11/32	70.00
	3 1/2	PEU356		PU356														
363	3 15/16	PEU363	11 1/16	PU363	11 1/16	5 11/16	14 1/2	17 5/16	5 9/16	5	1	2 9/16	7	1 1/2	3 9/32	3 11/16	11/32	98.00

Additional Notes

- Please call 1-866-REXNORD for availability
- Lubrication fitting tap size: for expansion units with shaft sizes 2 7/16 in and below, 1/4 in-28 UNF; for other expansion units and all fixed units, 1/8 in PT
- Base to centerline tolerance, +.000 in/-0.010 in (+0.00 mm/-0.25 mm)
- 1 1/8 in thru 1 7/16 in & 1 5/8 in thru 2 15/16 in shaft sizes also available with dual contact lip seals, add suffix N
- For the Selection Guide, Load Ratings and Speed Limits, see the Link-Belt 300 Series Heavy Duty Ball Bearings Engineering section on pages 426 - 429.

Note: Dimensions subject to change. Certified dimensions of ordered material furnished on request.

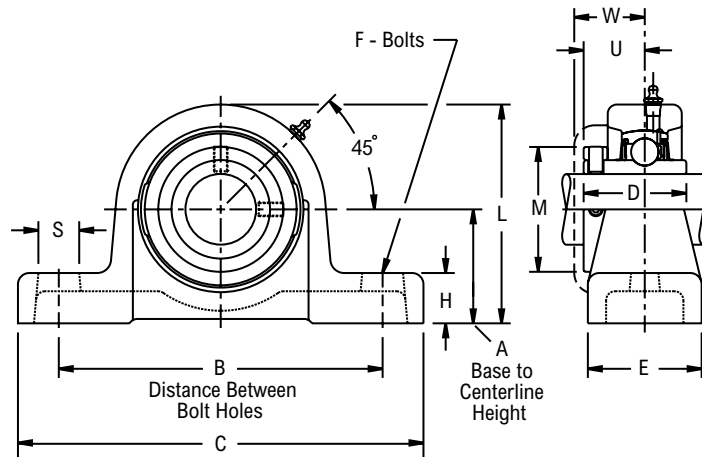
P2U300



Photo Shows a 2-Bolt Ball Bearing Pillow Block Unit

Product Features

- Corrosion-resistant powder coating
- Cast iron housing
- Spring locking setscrew mount
- Alignable & relubricatable
- High base to center height
- See Features and Benefits for additional info on page 424.



Bearing Dimensions

Size Code	Shaft Diameter	Part Number	A Base to Centerline Height	B Distance Between Bolt Holes	C	D	E	F Bolts	H	L	M	S	U	W	Approx. Weight
316	$\frac{7}{8}$	P2U314	2	$5\frac{1}{2}$	7	$1\frac{43}{64}$	2	$\frac{1}{2}$	$\frac{7}{8}$	$3\frac{11}{16}$	2	$\frac{7}{8}$	$\frac{63}{64}$	$1\frac{15}{64}$	4.20
	$\frac{15}{16}$	P2U315													
	1	P2U316													
319	$1\frac{1}{8}$	P2U318	$2\frac{3}{8}$	$6\frac{5}{8}$	$8\frac{1}{4}$	$1\frac{59}{64}$	$2\frac{3}{8}$	$\frac{1}{2}$	$\frac{7}{8}$	$4\frac{5}{16}$	$2\frac{5}{16}$	1	$1\frac{9}{64}$	$1\frac{13}{32}$	6.50
	$1\frac{3}{16}$	P2U319													
323	$1\frac{1}{4}$	P2U320	$2\frac{3}{4}$	$8\frac{1}{4}$	$10\frac{1}{8}$	$2\frac{3}{32}$	$2\frac{3}{4}$	$\frac{5}{8}$	$\frac{15}{16}$	$4\frac{7}{8}$	$2\frac{9}{16}$	$1\frac{1}{8}$	$1\frac{1}{4}$	$1\frac{1}{2}$	8.90
	$1\frac{3}{8}$	P2U322													
	$1\frac{7}{16}$	P2U323													
328	$1\frac{5}{8}$	P2U326	$3\frac{1}{8}$	9	11	$2\frac{19}{32}$	3	$\frac{5}{8}$	$1\frac{3}{16}$	$5\frac{3}{4}$	$3\frac{1}{4}$	$1\frac{1}{8}$	$1\frac{35}{64}$	$1\frac{27}{32}$	14.00
	$1\frac{11}{16}$	P2U327													
	$1\frac{3}{4}$	P2U328													
335	2	P2U332	$3\frac{3}{4}$	$10\frac{1}{4}$	$12\frac{5}{8}$	$3\frac{1}{16}$	$3\frac{3}{8}$	$\frac{3}{4}$	$1\frac{7}{16}$	$6\frac{7}{8}$	$3\frac{15}{16}$	$1\frac{3}{8}$	$1\frac{27}{32}$	$2\frac{3}{16}$	22.90
	$2\frac{1}{8}$	P2U334													
	$2\frac{3}{16}$	P2U335													
339	$2\frac{1}{4}$	P2U336	$4\frac{1}{8}$	$11\frac{1}{4}$	$13\frac{3}{4}$	$3\frac{5}{16}$	4	$\frac{3}{4}$	$1\frac{1}{2}$	$7\frac{1}{2}$	$4\frac{3}{16}$	$1\frac{3}{8}$	$1\frac{15}{16}$	$2\frac{7}{16}$	31.10
	$2\frac{7}{16}$	P2U339													
344	$2\frac{11}{16}$	P2U343	$4\frac{9}{16}$	12	$14\frac{13}{16}$	$3\frac{13}{16}$	$4\frac{3}{8}$	$\frac{7}{8}$	$1\frac{3}{4}$	$8\frac{7}{16}$	$4\frac{3}{4}$	$1\frac{3}{8}$	$2\frac{1}{4}$	$2\frac{5}{8}$	44.00
	$2\frac{3}{4}$	P2U344													
347	$2\frac{15}{16}$	P2U347	$4\frac{9}{16}$	$12\frac{3}{8}$	$15\frac{3}{8}$	$4\frac{3}{32}$	$4\frac{3}{8}$	$\frac{7}{8}$	$1\frac{7}{8}$	$8\frac{11}{16}$	$4\frac{15}{16}$	$1\frac{3}{8}$	$2\frac{3}{8}$	$2\frac{3}{4}$	47.20

Additional Notes

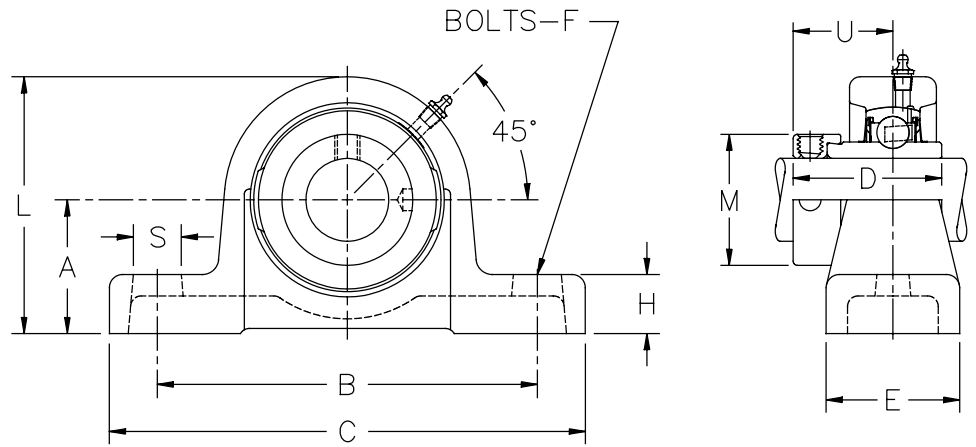
- Please call 1-866-REXNORD for availability
- Lubrication fitting tap size, 1/8 in PT
- Base to centerline tolerance, +.000 in/-.010 in ($+0.00\text{ mm}/-0.25\text{ mm}$)
- $1\frac{1}{8}$ in thru $1\frac{7}{16}$ in & $1\frac{5}{8}$ in thru $2\frac{15}{16}$ in shaft sizes also available with dual contact lip seals, add suffix N
- For the Selection Guide, Load Ratings and Speed Limits, see the Link-Belt 300 Series Heavy Duty Ball Bearings Engineering section on pages 426 - 429.
- Note: Dimensions subject to change. Certified dimensions of ordered material furnished on request.



Photo Shows a 2-Bolt Ball Bearing Pillow Block Unit

Product Features

- Corrosion-resistant powder coating
- Cast iron housing
- Eccentric cam locking device
- Alignable & relubricatable
- Low base to center height
- See Features and Benefits for additional info on page 424.



Bearing Dimensions

Size Code	Shaft Diameter	Part Number	A Base to Centerline Height	B Distance Between Bolt Holes	C	D	E	F Bolts	H	L	M	S	U	Approx. Weight
319	1 3/16	PLY319N	1 7/8	5 3/8	6 13/16	2 1/32	1 15/16	1/2	7/8	3 11/16	1 15/16	3/4	1 1/4	4.60
323	1 7/16	PLY323N	2 1/8	6	7 9/16	2 5/32	2 1/8	1/2	15/16	4 3/32	2 3/16	3/4	1 5/16	5.90
328	1 11/16	PLY327N	2 5/8	7 1/2	9 7/16	2 9/16	2 5/8	5/8	1 3/16	5 1/8	2 3/4	1	1 33/64	11.30
331	1 15/16	PLY331N	2 13/16	8 1/4	10 7/16	2 25/32	2 7/8	5/8	1 9/16	5 9/16	3	1	1 41/64	15.00
335	2 3/16	PLY335N	3 1/16	9	11 5/16	2 15/16	3 1/8	3/4	1 7/16	6 1/32	3 1/4	1 1/8	1 23/32	18.50
339	2 7/16	PLY339N	3 5/16	9 3/4	12 5/16	3 3/32	3 5/16	3/4	1 1/2	6 17/32	3 1/2	1 1/8	1 25/32	23.20
344	2 11/16	PLY343N	3 13/16	11 1/4	14 3/16	3 9/16	3 13/16	7/8	1 3/4	7 9/16	4	1 5/16	2	36.10
347	2 15/16	PLY347N	4 1/8	12	15 1/8	3 15/16	4 1/16	7/8	1 7/8	8 1/8	4 7/16	1 5/16	2 7/32	43.40

Additional Notes

- Please call 1-866-REXNORD for availability
- Lubrication fitting tap size, 1/8 in PT
- Base to centerline tolerance, +.000 in/-0.010 in (+0.00 mm/-0.25 mm)
- N dual contact lip seals standard
- For the Selection Guide, Load Ratings and Speed Limits, see the Link-Belt 300 Series Heavy Duty Ball Bearings Engineering section on pages 426 - 429.
- Note: Dimensions subject to change. Certified dimensions of ordered material furnished on request.

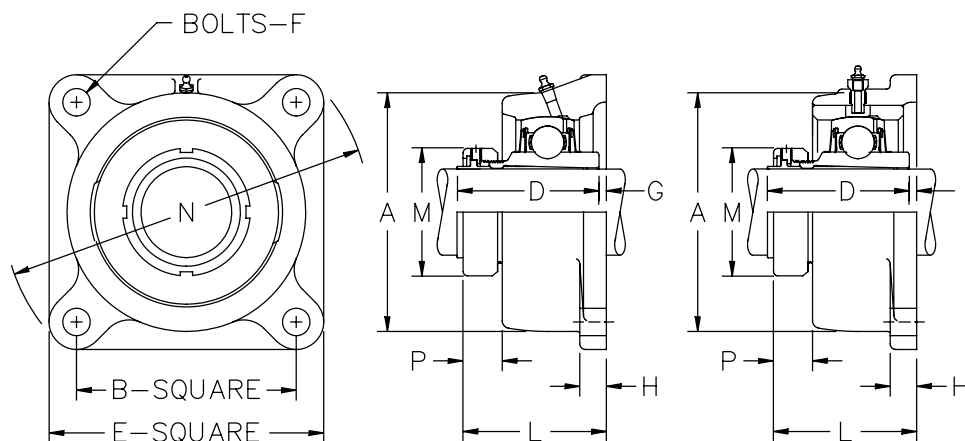
FA300, FEA300



Photo Shows a 4-Bolt Ball Bearing Flanged Unit

Product Features

- Spyglass Optical Strain Sensor (OSS) Technology
 - Positive locking system
 - Tapered adapter sleeve
 - Corrosion-resistant powder coating
 - Cast iron housing
 - Fixed or Expansion - up to 3/8 in. Expansion
 - Alignable & relubricatable
- See Features and Benefits for additional info on page 424.



Bearing Dimensions

Size Code	Shaft Diameter	Expansion		Fixed		B Distance Between Bolt Holes	L Mounting Surface to Collar Face	D	E	F Bolts	G	H	M	N	P	Total Axial Expansion	Approx. Weight
		Part Number	A	Part Number	A												
319	1 ³ / ₁₆	FEA319	4 ¹ / ₈	FA319	3 ⁵ / ₈	3 ¹³ / ₁₆	2 ⁷ / ₈	2 ³ / ₄	4 ¹⁵ / ₁₆	1 ¹ / ₂	1 ¹ / ₈	5 ⁵ / ₈	2 ⁵ / ₃₂	6 ¹⁷ / ₃₂	1 ⁷ / ₃₂	3 ³ / ₁₆	5.00 lb
323	1 ⁷ / ₁₆	FEA323	4 ¹⁵ / ₃₂	FA323	4 ¹ / ₁₆	4	2 ²⁹ / ₃₂	2 ⁴⁷ / ₆₄	5 ¹ / ₈	5 ⁵ / ₈	5 ⁵ / ₃₂	5 ⁵ / ₈	2 ³ / ₈	6 ²⁵ / ₃₂	1 ³ / ₃₂	3 ³ / ₁₆	6.20 lb
328	1 ¹¹ / ₁₆	FEA327	5 ¹ / ₂	FA327	5	4 ⁷ / ₈	3 ²⁵ / ₆₄	3 ¹ / ₈	6 ¹ / ₄	5 ⁵ / ₈	1 ¹ / ₄	1 ¹¹ / ₁₆	2 ⁴¹ / ₆₄	8 ⁹ / ₃₂	1 ⁹ / ₃₂	3 ³ / ₁₆	10.40 lb
331	1 ¹⁵ / ₁₆	FEA331	5 ¹⁵ / ₁₆	FA331	5 ¹ / ₂	5 ¹ / ₈	3 ²⁷ / ₆₄	3 ⁷ / ₃₂	6 ¹ / ₂	5 ⁵ / ₈	5 ⁵ / ₃₂	1 ¹¹ / ₁₆	2 ⁵⁵ / ₆₄	8 ⁵ / ₈	1 ⁷ / ₆₄	1 ¹ / ₄	12.50 lb
335	2 ³ / ₁₆	FEA335	6 ³ / ₈	FA335	6	5 ³ / ₄	3 ³³ / ₆₄	3 ²³ / ₆₄	7 ⁵ / ₁₆	3 ³ / ₄	5 ⁵ / ₃₂	3 ³ / ₄	3 ¹⁵ / ₆₄	9 ¹¹ / ₁₆	6 ¹ / ₆₄	9 ⁹ / ₃₂	17.00 lb
339	2 ⁷ / ₁₆	FEA339	6 ¹³ / ₁₆	FA339	6 ³ / ₈	6	3 ⁵⁹ / ₆₄	3 ²⁷ / ₃₂	7 ⁵ / ₈	3 ³ / ₄	5 ⁵ / ₃₂	3 ³ / ₄	3 ¹⁹ / ₃₂	10 ¹ / ₈	1 ¹ / ₈	9 ⁹ / ₃₂	19.00 lb
344	2 ¹¹ / ₁₆	FEA343	7 ³ / ₄	FA343	7 ⁵ / ₁₆	7	4 ¹³ / ₃₂	4 ¹ / ₄	8 ⁷ / ₈	7 ⁷ / ₈	5 ⁵ / ₃₂	7 ⁷ / ₈	4 ³ / ₃₂	11 ²⁵ / ₃₂	1 ³ / ₁₆	7 ⁷ / ₃₂	30.00 lb
	2 ³ / ₄	FEA344		FA344													
347	2 ¹⁵ / ₁₆	FEA347	8 ¹ / ₄	FA347	7 ⁷ / ₈	7 ¹ / ₄	4 ⁴⁷ / ₆₄	4 ¹⁷ / ₃₂	9 ¹ / ₁₆	7 ⁷ / ₈	7 ⁷ / ₃₂	7 ⁷ / ₈	4 ³ / ₃₂	12 ¹⁷ / ₁₆	1 ¹⁹ / ₆₄	7 ⁷ / ₃₂	34.00 lb
356	3 ⁷ / ₁₆	FEA355	9 ⁷ / ₈	FA355	9 ¹ / ₄	8 ¹ / ₂	5 ³⁷ / ₆₄	5 ²³ / ₆₄	11	1	7 ⁷ / ₃₂	1 ¹ / ₄	4 ⁶¹ / ₆₄	14 ¹⁷ / ₃₂	1 ²⁷ / ₆₄	11 ¹¹ / ₃₂	50.00 lb
363	3 ¹⁵ / ₁₆	FEA363	10 ¹⁵ / ₁₆	FA363	10 ³ / ₈	9 ¹ / ₂	6 ¹ / ₈	5 ²⁹ / ₃₂	12 ¹ / ₈	1	7 ⁷ / ₃₂	1 ³ / ₈	5 ⁴³ / ₆₄	16 ¹ / ₁₆	1 ²⁷ / ₆₄	11 ¹¹ / ₃₂	82.00 lb

Additional Notes

- Please call 1-866-REXNORD for availability
- Lubrication fitting tap size: for expansion units with shaft sizes 2 7/16 in and below, 1/4 in-28 UNF; for other expansion units and all fixed units, 1/8 in PT
- 1 1/8 in thru 1 7/16 in & 1 5/8 in thru 2 15/16 shaft sizes also available with dual contact lip seals, add suffix N
- For the Selection Guide, Load Ratings and Speed Limits, see the Link-Belt 300 Series Heavy Duty Ball Bearings Engineering section on pages 426 - 429.
- Note: Dimensions subject to change. Certified dimensions of ordered material furnished on request.

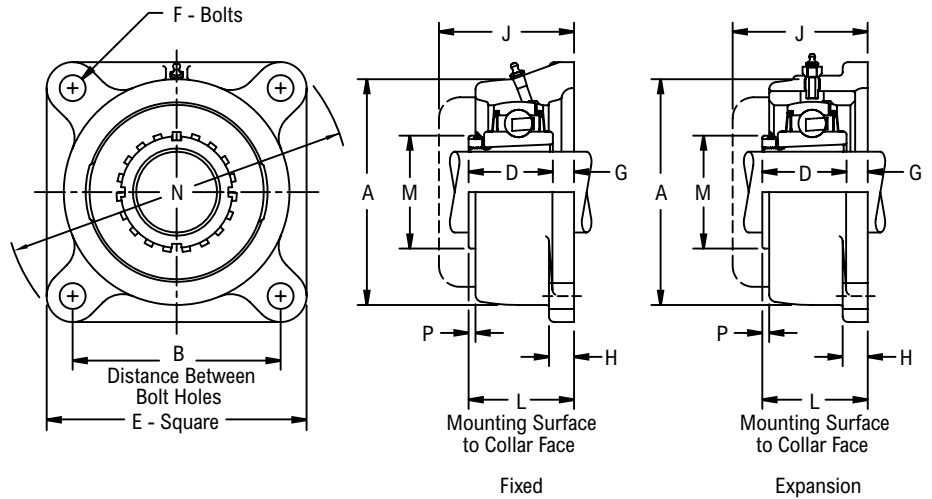
FU3K00, FEU3K00



Photo Shows a 4-Bolt Ball Bearing Flanged Unit

Product Features

- Corrosion-resistant powder coating
- Cast iron housing
- Enhanced life mounting style
- Fixed or Expansion - Up to 11/32 in expansion
- Alignable & relubricatable
- See Features and Benefits for additional info on page 424.



Bearing Dimensions

Size Code	Shaft Diameter	Expansion		Fixed		B Distance Between Bolt Holes	L Mounting Surface to Collar Face	D	E	F Bolts	G	H	J	M	N	P	Total Axial Expansion	Approx. Weight
		Part Number	A	Part Number	A													
331	1 11/16	FEU3K27	5 15/16	FU3K27	5 1/2	5 1/8	2 27/32	2 17/32	6 1/2	5/8	2 1/64	1 1/16	3 17/64	2 11/16	8 5/8	1 17/32	1/4	12.00
335	1 15/16	FEU3K31	6 3/8	FU3K31	6	5 3/4	2 61/64	2 19/32	7 5/16	3/4	23/64	3/4	3 9/16	2 31/32	9 11/16	2 25/64	9/32	17.60
344	2 3/16	FEU3K35	7 3/4	FU3K35	7 5/16	7	3 35/64	3 1/32	8 7/8	7/8	17/32	7/8	4 11/32	3 7/8	11 25/32	2 1/64	7/32	26.90
347	2 7/16	FEU3K39	8 1/4	FU3K39	7 7/8	7 1/4	3 7/8	3 3/16	9 1/16	7/8	11/16	7/8	4 11/16	3 7/8	12 1/16	7/32	7/32	30.80
356	2 15/16	FEU3K47	9 7/8	FU3K47	9 1/4	8 1/2	4 3/8	3 17/32	11	1	27/32	1 1/4	5 17/32	4 13/32	14 17/32	7/32	1 1/32	49.70
363	3 7/16	FEU3K55	10 15/16	FU3K55	10 3/8	9 1/2	4 59/64	3 31/32	12 1/8	1 1/8	15/16	1 3/8	6 3/16	5 3/16	16 1/16	15/64	1 1/32	65.30

Additional Notes

- Please call 1-866-REXNORD for availability
- Lubrication fitting tap size: for expansion units with shaft sizes 1 15/16 in and below, 1/4 in-28 UNF; for other expansion units and all fixed units, 1/8 in PT
- 1 11/16 in thru 2 7/16 in shaft sizes also available with dual contact lip seals, add suffix N
- For the Selection Guide, Load Ratings and Speed Limits, see the Link-Belt 300 Series Heavy Duty Ball Bearings Engineering section on pages 426 - 429.
- Note: Dimensions subject to change. Certified dimensions of ordered material furnished on request.

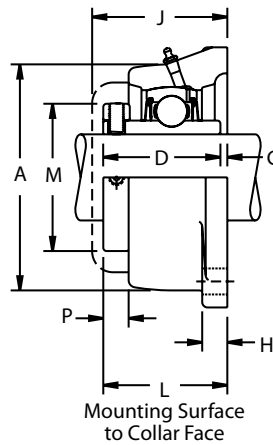
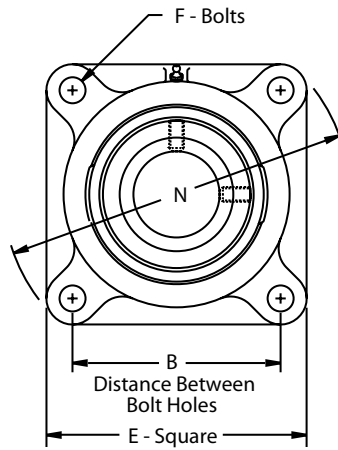
FU300, FEU300



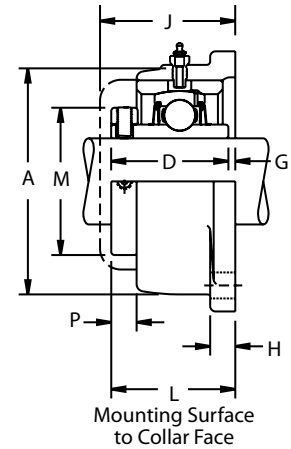
Photo Shows a 4-Bolt Ball Bearing Flanged Unit

Product Features

- Corrosion-resistant powder coating
- Cast iron housing
- Spring locking setscrew mount
- Fixed or Expansion - Up to 11/32 in expansion
- Alignable & relubricatable
- See Features and Benefits for additional info on page 424.



Fixed



Expansion

Bearing Dimensions

Size Code	Shaft Diameter	Expansion		Fixed		B Distance Between Bolt Holes	L Mounting Surface to Collar Face	D	E	F Bolts	G	H	J	M	N	P	Total Axial Expansion	Approx. Weight
		Part Number	A	Part Number	A													
316	7/8	FEU314	3 11/16	FU314	3 1/4	3 1/2	1 51/64	1 43/64	4 5/8	1/2	1/8	9/16	2 3/64	2	6 1/16	19/64	3/16	4.00
	15/16	FEU315		FU315														
	1	FEU316		FU316														
319	1 1/8	FEU318	4 1/8	FU318	3 5/8	3 13/16	2 3/64	1 59/64	4 15/16	1/2	1/8	5/8	2 5/16	2 5/16	6 17/32	25/64	3/16	4.70
	1 3/16	FEU319		FU319														
323	1 1/4	FEU320	4 15/32	FU320	4 1/16	4	2 1/4	2 3/32	5 1/8	1/2	5/32	5/8	2 1/2	2 9/16	6 25/32	7/16	9/32	6.00
	1 3/8	FEU322		FU322														
	1 7/16	FEU323		FU323														
324	1 1/2	FEU324	5	FU324	4 9/16	4 5/8	2 15/32	2 5/16	6	5/8	5/32	5/8	2 11/16	3 1/16	7 29/32	1/2	9/32	8.50
	1 5/8	FEU326		FU326														
328	1 11/16	FEU327	5 1/2	FU327	5	4 7/8	2 3/4	2 19/32	6 1/4	5/8	5/32	11/16	3 3/64	3 1/4	8 9/32	35/64	3/16	10.20
	1 3/4	FEU328		FU328														
	1 15/16	FEU331		FU331														
331	2	FEU332	5 15/16	FU332	5 1/2	5 1/8	2 31/32	2 13/16	6 1/2	5/8	5/32	11/16	3 17/64	3 7/16	8 5/8	37/64	1/4	12.20
	2 1/8	FEU334		FU334														
	2 3/16	FEU335		FU335														
335	2 1/4	FEU336	6 3/8	FU336	6	5 3/4	3 7/32	3 1/16	7 5/16	3/4	5/32	3/4	3 9/16	3 15/16	9 11/16	21/32	9/32	16.50
	2 7/16	FEU339		FU339														
339	2 1/4	FEU336	6 13/16	FU336	6 3/8	6	3 15/32	3 5/16	7 5/8	3/4	5/32	3/4	3 31/32	4 3/16	10 1/8	21/32	9/32	19.20
	2 7/16	FEU339		FU339														
344	2 11/16	FEU343	7 3/4	FU343	7 5/16	7	3 31/32	3 13/16	8 7/8	7/8	5/32	7/8	4 11/32	4 3/4	11 25/32	3/4	7/32	30.00
	2 3/4	FEU344		FU344														
347	2 15/16	FEU347	8 1/4	FU347	7 7/8	7 1/4	4 5/16	4 3/32	9 1/16	7/8	7/32	7/8	4 11/16	4 15/16	12 1/16	7/8	7/32	33.50
	3 7/16	FEU355		FU355														
356	3 1/2	FEU356	9 7/8	FU356	9 1/4	8 1/2	5 5/32	4 15/16	11	1	7/32	1 1/4	5 17/32	6	14 17/32	1	11/32	58.00
	3 15/16	FEU363		FU363														
363	3 15/16	FEU363	10 15/16	FU363	10 3/8	9 1/2	5 25/32	5 9/16	12 1/8	1 1/8	7/32	1 3/8	6 3/16	7	16 1/16	1 3/32	11/32	78.00

Additional Notes

- Please call 1-866-REXNORD for availability
- Lubrication fitting tap size: for expansion units with shaft sizes 2 7/16 in and below, 1/4 in-28 UNF; for other expansion units and all fixed units, 1/8 in PT
- 1 1/8 in thru 1 7/16 in & 1 5/8 in thru 2 15/16 in shaft sizes also available with dual contact lip seals, add suffix N
- For the Selection Guide, Load Ratings and Speed Limits, see the Link-Belt 300 Series Heavy Duty Ball Bearings Engineering section on pages 426 - 429.
- Note: Dimensions subject to change. Certified dimensions of ordered material furnished on request.

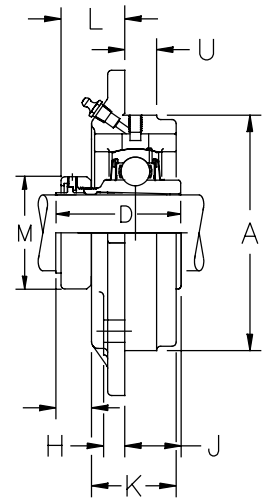
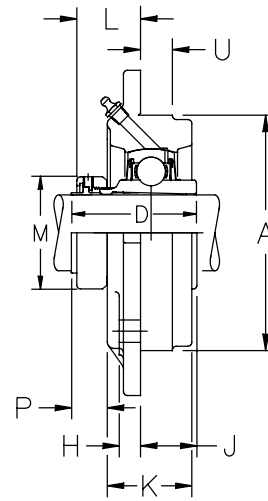
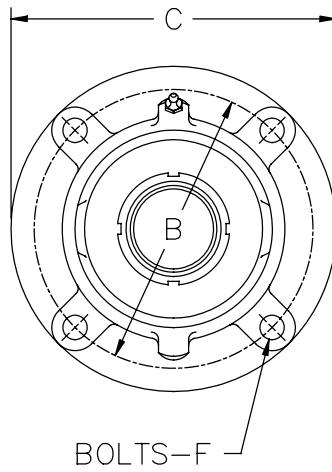
FCA300, FCEA300



Photo Shows a 4-Bolt Ball Bearing Flanged Cartridge Unit

Product Features

- Spyglass Optical Strain Sensor (OSS) Technology
- Positive locking system
- Tapered adapter sleeve
- Corrosion-resistant powder coating
- Cast iron housing
- Fixed or Expansion - up to 3/8 in. Expansion
- Alignable & relubricatable
- See Features and Benefits for additional info on page 424.



Bearing Dimensions

Size Code	Shaft Diameter	Expansion		A Pilot Diameter	B Bolt Hole Circle Diameter	L Mounting Surface to Collar Face	C	D	F Bolts	H	J	K	M	P	U	Total Axial Expansion	Approx. Weight
		Part Number	Part Number														
319	1 3/16	-	FCA319	4.125	5	1 7/8	6	2 3/4	7/16	7/16	3 1/32	1 7/16	2 5/32	1 7/32	5/8	-	5.50 lb
323	1 7/16	FCEA323	FCA323	4.500	5 3/8	1 21/32	6 3/8	2 47/64	7/16	7/16	1 3/32	1 9/16	2 3/8	1 3/32	5/8	3/16	6.20 lb
328	1 11/16	FCEA327	FCA327	5.500	6 1/2	1 63/64	7 5/8	3 1/8	1/2	1/2	1 5/32	1 59/64	2 41/64	1 5/8	3/4	3/16	11.25 lb
331	1 15/16	FCEA331	FCA331	6.000	7	1 7/8	8 1/8	3 7/32	1/2	9/16	1 25/64	2 1/8	2 55/64	1 1/64	7/8	1/4	15.00 lb
335	2 3/16	FCEA335	FCA335	6.375	7 5/8	1 53/64	9	3 23/64	5/8	5/8	1 17/32	2 9/32	3 15/64	1 61/64	15/16	9/32	19.00 lb
339	2 7/16	FCEA339	FCA339	6.875	8 1/8	1 5/64	9 1/2	3 27/32	5/8	5/8	1 11/16	2 15/32	3 19/32	1 7/64	15/16	9/32	22.00 lb
344	2 11/16	FCEA343	FCA343	7.750	9	2 5/16	10 3/8	4 1/4	5/8	3/4	1 15/16	2 27/32	4 3/32	1 15/64	1 1/8	7/32	33.00 lb
	2 3/4	FCEA344	FCA344														
347	2 15/16	FCEA347	FCA347	8.250	9 1/2	2 7/16	10 7/8	4 17/32	5/8	3/4	2 3/32	3 1/8	4 3/32	1 3/16	1 1/8	7/32	37.00 lb
356	3 7/16	FCEA355	FCA355	9.875	11 3/8	2 53/64	12 7/8	5 23/64	3/4	7/8	2 17/32	3 11/16	4 61/64	1 27/64	1 1/4	11/32	64.00 lb
363	3 15/16	FCEA363	FCA363	11.000	12 1/2	3 1/8	14	5 29/32	3/4	7/8	2 25/32	4 7/32	5 43/64	1 27/64	1 3/8	11/32	85.00 lb

Additional Notes

- Please call 1-866-REXNORD for availability
- Lubrication fitting tap size: for shaft sizes 1 3/16 in and below, 1/4 in-28 UNF; for all other shaft sizes, 1/8 in PT
- Pilot Diameter tolerance, +.000 in/- .002 in (+0.00 mm/-0.05 mm)
- Bore tolerance for mounting, +.002 in/- .000 in (+0.05 mm/-0.00 mm)
- 1 1/8 in thru 1 7/16 in & 1 5/8 in thru 2 15/16 in shaft sizes also available with dual contact lip seals, add suffix N

For the Selection Guide, Load Ratings and Speed Limits, see the Link-Belt 300 Series Heavy Duty Ball Bearings Engineering section on pages 426 - 429.
 Note: Dimensions subject to change. Certified dimensions of ordered material furnished on request.

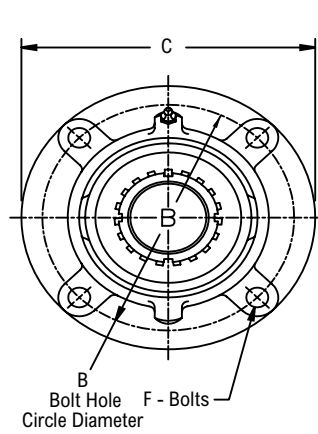
FCU3K00, FCEU3K00



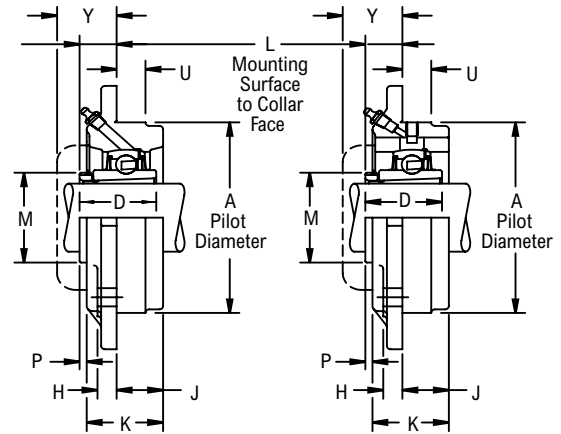
Photo Shows a 4-Bolt Ball Bearing Flanged Cartridge Unit

Product Features

- Corrosion-resistant powder coating
- Cast iron housing
- Enhanced life mounting style
- Fixed or Expansion - Up to 13/32 in expansion
- Alignable & relubricatable
- See Features and Benefits for additional info on page 424.



B Bolt Hole Circle Diameter
F - Bolts



Fixed

Expansion

Bearing Dimensions

Size Code	Shaft Diameter	Expansion		Fixed		A Pilot Diameter	B Bolt Hole Circle Diameter	L Mounting Surface to Collar Face	C	D	F Bolts	H	J	K	M	P	U	Y	Total Axial Expansion	Approx. Weight
		Part Number	Part Number																	
331	1 11/16	FCEU3K27	FCU3K27	6.000	7	1 5/16	8 1/8	2 17/32	1/2	9/16	1 13/64	2 1/8	2 11/16	39/64	7/8	1 23/32	1/4	14.80		
335	1 15/16	FCEU3K31	FCU3K31	6.375	7 5/8	1 17/64	9	2 19/32	5/8	5/8	1 5/16	2 9/32	2 31/32	25/64	15/16	1 7/8	1/4	20.90		
344	2 3/16	FCEU3K35	FCU3K35	7.750	9	1 29/64	10 3/8	3 1/32	5/8	3/4	1 9/16	2 27/32	3 3/8	3/8	1 1/8	2 1/4	13/32	30.50		
347	2 7/16	FCEU3K39	FCU3K39	8.250	9 1/2	1 9/16	10 7/8	3 3/16	5/8	3/4	1 5/8	3 1/8	3 7/8	5/16	1 1/8	2 3/8	13/32	31.80		
356	2 15/16	FCEU3K47	FCU3K47	9.875	11 3/8	1 5/8	12 7/8	3 17/32	3/4	7/8	1 29/32	3 11/16	4 13/32	7/32	1 1/4	2 25/32	13/32	55.00		
363	3 7/16	FCEU3K55	FCU3K55	11.000	12 1/2	1 59/64	14	3 31/32	3/4	7/8	2 1/16	4 7/32	5 3/16	15/64	1 3/8	3 3/16	13/32	71.40		

Additional Notes

- Please call 1-866-REXNORD for availability
- Lubrication fitting tap size, 1/8 in PT
- Pilot Diameter tolerance, +.000 in/-0.002 in (*+0.00 mm/-0.05 mm*)
- Bore tolerance for mounting, +.002 in/-0.000 in (*+0.05 mm/-0.00 mm*)
- 1 11/16 in thru 2 7/16 in shaft sizes also available with dual contact lip seals, add suffix N
- For the Selection Guide, Load Ratings and Speed Limits, see the Link-Belt 300 Series Heavy Duty Ball Bearings Engineering section on pages 426 - 429.

Note: Dimensions subject to change. Certified dimensions of ordered material furnished on request.

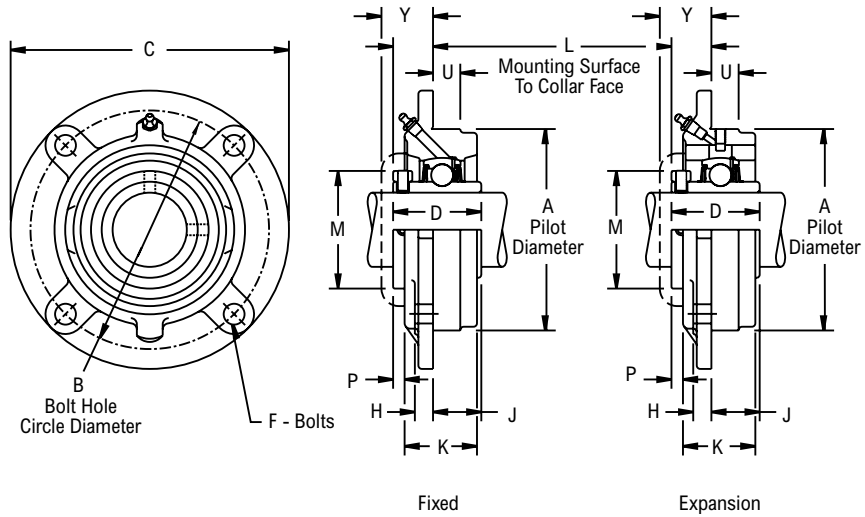
FCU300, FCEU300



Photo Shows a 4-Bolt Ball Bearing Flanged Cartridge Unit

Product Features

- Corrosion-resistant powder coating
- Cast iron housing
- Spring locking setscrew mount
- Fixed or Expansion - Up to 13/32 in expansion
- Alignable & relubricatable
- See Features and Benefits for additional info on page 424.



Bearing Dimensions

Size Code	Shaft Diameter	Expansion	Fixed	A Pilot Diameter	B Bolt Hole Circle Diameter	L Mounting Surface to Collar Face	C	D	F Bolts	H	J	K	M	P	U	Y	Total Axial Expansion	Approx. Weight
		Part Number	Part Number															
312	3/4	-	FCU312	3.125	3 3/4	21/32	4 1/2	1 15/32	5/16	7/16	13/16	1 7/32	1 5/8	13/64	1/2	55/64	-	3.00
316	7/8	-	FCU314	3.688	4 1/2	51/64	5 3/8	1 43/64	3/8	7/16	7/8	1 5/16	2	19/64	5/8	1 3/64	-	4.50
	15/16	-	FCU315															
319	1	-	FCU316	4.125	5	61/64	6	1 59/64	7/16	7/16	31/32	1 7/16	2 5/16	25/64	5/8	1 7/32	-	6.00
	1 1/8	-	FCU318															
323	1 1/4	FCEU320	FCU320	4.500	5 3/8	1	6 3/8	2 3/32	7/16	7/16	1 3/32	1 9/16	2 9/16	7/16	5/8	1 1/4	1/4	7.50
	1 3/8	FCEU322	FCU322															
	1 7/16	FCEU323	FCU323															
324	1 1/2	FCEU324	FCU324	5.000	6	1 9/64	7 1/8	2 5/16	1/2	1/2	1 11/64	1 23/32	3 1/16	1/2	5/8	1 23/64	1/4	10.00
	1 5/8	FCEU326	FCU326															
	1 11/16	FCEU327	FCU327															
328	1 3/4	FCEU328	FCU328	5.500	6 1/2	1 19/64	7 5/8	2 19/32	1/2	1/2	1 19/64	1 59/64	3 1/4	35/64	3/4	1 19/32	1/4	12.20
	1 15/16	FCEU331	FCU331															
	2	FCEU332	FCU332															
331	1 15/16	FCEU331	FCU331	6.000	7	1 27/64	8 1/8	2 13/16	1/2	9/16	1 25/64	2 1/8	3 7/16	9/16	7/8	1 23/32	1/4	15.00
	2	FCEU332	FCU332															
	2 1/8	FCEU334	FCU334															
335	2 3/16	FCEU335	FCU335	6.375	7 5/8	1 17/32	9	3 1/16	5/8	5/8	1 17/32	2 9/32	3 15/16	21/32	15/16	1 7/8	1/4	19.50
	2 1/4	FCEU336	FCU336															
339	2 7/16	FCEU339	FCU339	6.875	8 1/8	1 5/8	9 1/2	3 5/16	5/8	5/8	1 11/16	2 15/32	4 3/16	21/32	15/16	2 1/8	1/4	23.50
	2 11/16	FCEU343	FCU343															
344	2 3/4	FCEU344	FCU344	7.750	9	1 7/8	10 3/8	3 13/16	5/8	3/4	1 15/16	2 27/32	4 3/4	25/32	1 1/8	2 1/4	13/32	32.50
	2 15/16	FCEU347	FCU347															
347	3 7/16	FCEU355	FCU355	8.250	9 1/2	2	10 7/8	4 3/32	5/8	3/4	2 3/32	3 1/8	4 15/16	3/4	1 1/8	2 3/8	13/32	37.00
	3 1/2	FCEU356	FCU356															
356	3 7/16	FCEU355	FCU355	9.875	11 3/8	2 13/32	12 7/8	4 15/16	3/4	7/8	2 17/32	3 11/16	6	1	1 1/4	2 25/32	13/32	64.00
	3 1/2	FCEU356	FCU356															
363	3 15/16	FCEU363	FCU363	11.000	12 1/2	2 25/32	14	5 9/16	3/4	7/8	2 25/32	4 7/32	7	1 3/32	1 3/8	3 3/16	13/32	85.00

Additional Notes

- Please call 1-866-REXNORD for availability
- Lubrication fitting tap size: for shaft sizes 1 3/16 in and below, 1/4 in-28 UNF: for all other shaft sizes, 1/8 in PT
- Pilot Diameter tolerance, +.000 in/--.002 in (+0.00 mm/-0.05 mm)
- Bore tolerance for mounting, +.002 in/--.000 in (+0.05 mm/-0.00 mm)
- 1 1/8 in thru 1 7/16 in & 1 5/8 in thru 2 15/16 in shaft sizes also available with dual contact lip seals, add suffix N

For the Selection Guide, Load Ratings and Speed Limits, see the Link-Belt 300 Series Heavy Duty Ball Bearings Engineering section on pages 426 - 429.
 Note: Dimensions subject to change. Certified dimensions of ordered material furnished on request.

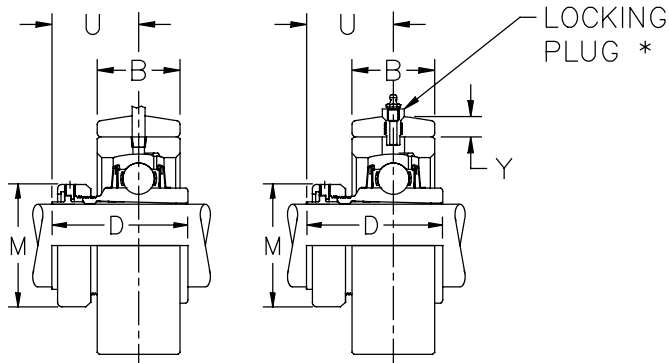
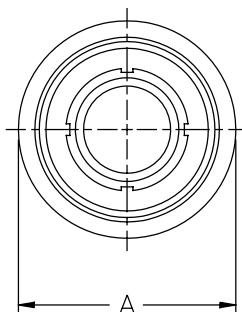
CA300, CEA300



Photo Shows a Ball Bearing Cartridge Unit with Steel Housing

Product Features

- Spyglass Optical Strain Sensor (OSS) Technology
- Positive locking system
- Tapered adapter sleeve
- Corrosion-resistant powder coating
- Cast iron housing
- Fixed or Expansion - up to 3/8 in. Expansion
- Alignable & relubricatable
- See Features and Benefits for additional info on page 424.



Bearing Dimensions

Size Code	Shaft Diameter	Expansion		Fixed		A O.D.	B Cartridge Housing Width	D	M	U	Y	Total Axial Expansion	Approx. Weight
		Part Number	Part Number										
319	1 3/16	-	CA319	3.4380	1 3/8	2 3/4	2 5/32	1 63/64	13/32	-	2.68 lb		
323	1 7/16	CEA323	CA323	3.7500	1 1/2	2 47/64	2 3/8	1 29/32	9/16	3/16	3.30 lb		
328	1 11/16	CEA327	CA327	4.5940	1 27/32	3 1/8	2 41/64	2 7/32	9/16	3/16	6.20 lb		
331	1 15/16	CEA331	CA331	5.0000	2 1/32	3 7/32	2 55/64	2 1/8	19/32	1/4	8.00 lb		
335	2 3/16	CEA335	CA335	5.3750	2 3/16	3 23/64	3 15/64	2 9/64	11/16	9/32	10.00 lb		
339	2 7/16	CEA339	CA339	5.7810	2 3/8	3 27/32	3 19/32	2 25/64	23/32	9/32	11.50 lb		
344	2 11/16	CEA343	CA343	6.5620	2 3/4	4 1/4	4 3/32	2 11/16	13/16	7/32	17.00 lb		
	2 3/4	CEA344	CA344										
347	2 15/16	CEA347	CA347	6.9690	3	4 17/32	4 3/32	2 51/64	13/16	7/32	20.00 lb		
351	3 3/16	CEA351	CA351	7.5940	3 3/16	5 1/2	4 61/64	3 11/16	1	11/32	27.00 lb		
356	3 7/16	CEA355	CA355	8.3750	3 9/16	5 23/64	4 61/64	3 21/64	1	11/32	36.00 lb		
363	3 15/16	CEA363	CA363	9.3750	4 1/16	5 29/32	5 43/64	3 5/8	1	11/32	50.00 lb		

Additional Notes

- Please call 1-866-REXNORD for availability
- Lubrication fitting tap size: for expansion units with shaft sizes 2 7/16 in and below, 1/4 in-28 UNF; for other expansion units and all fixed units, 1/8 in PT
- O.D. tolerance, +.000 in/- .002 in (+0.00 mm/-0.05 mm)
- Bore tolerance for mounting, +.002 in/- .000 in (+0.05 mm/-0.00 mm)
- 1 1/8 in thru 1 7/16 in & 1 5/8 in thru 2 15/16 in shaft sizes also available with dual contact lip seals, add suffix N

Locking plug thread sizes: for shaft sizes 2 7/16 in and below, 7/16 in-20 UNF; for all other shaft sizes, 5/8 in-18 UNF

For the Selection Guide, Load Ratings and Speed Limits, see the Link-Belt 300 Series Heavy Duty Ball Bearings Engineering section on pages 426 - 429.

Note: Dimensions subject to change. Certified dimensions of ordered material furnished on request.

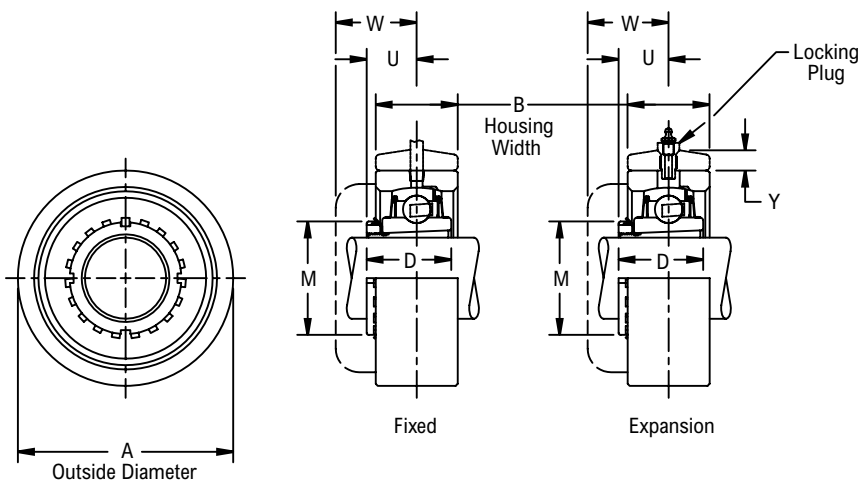
CU3K00, CEU3K00



Photo Shows a Ball Bearing Cartridge Unit with Steel Housing

Product Features

- Steel housing
- Enhanced life mounting style
- Fixed or Expansion - Up to 11/32 in expansion
- Alignable & relubricatable
- See Features and Benefits for additional info on page 424.



Bearing Dimensions

Size Code	Shaft Diameter	Expansion	Fixed	A O.D.	B Cartridge Housing Width	D	M	U	W	Y	Total Axial Expansion	Approx. Weight
		Part Number	Part Number									
331	1 11/16	CEU3K27	CU3K27	5.0000	2 1/32	2 17/32	2 11/16	1 35/64	1 31/32	19/32	1/4	7.70
335	1 15/16	CEU3K31	CU3K31	5.3750	2 3/16	2 19/32	2 31/32	1 37/64	2 3/16	11/16	9/32	9.70
344	2 3/16	CEU3K35	CU3K35	6.5620	2 3/4	3 1/32	3 3/8	1 53/64	2 5/8	13/16	7/32	17.00
347	2 7/16	CEU3K39	CU3K39	6.9690	3	3 3/16	3 7/8	1 15/16	2 3/4	13/16	7/32	19.70
351	2 11/16	CEU3K43	CU3K43	7.5940	3 3/16	3 5/16	4 5/32	2	3	1	11/32	26.90
356	2 15/16	CEU3K47	CU3K47	8.3750	3 9/16	3 17/32	4 13/32	2 1/8	3 9/32	1	11/32	35.50
363	3 7/16	CEU3K55	CU3K55	9.3750	4 1/16	3 31/32	5 3/16	2 27/64	3 11/16	1	11/32	49.50

Additional Notes

- Please call 1-866-REXNORD for availability
- Lubrication fitting tap size: for expansion units with shaft sizes 1 15/16 in and below, 1/4 in-28 UNF; for other expansion units and all fixed units, 1/8 in PT
- O.D. tolerance, +.000 in/-0.002 in (+0.00 mm/-0.05 mm)
- Bore tolerance for mounting, +.002 in/-0.000 in (+0.05 mm/-0.00 mm)
- 1 11/16 in thru 2 7/16 in shaft sizes also available with dual contact lip seals, add suffix N
- Locking plug thread sizes: for shaft sizes 1 15/16 in and below, 7/16 in-20 UNF; for all other shaft sizes, 5/8 in-18 UNF

For the Selection Guide, Load Ratings and Speed Limits, see the Link-Belt 300 Series Heavy Duty Ball Bearings Engineering section on pages 426 - 429.
 Note: Dimensions subject to change. Certified dimensions of ordered material furnished on request.

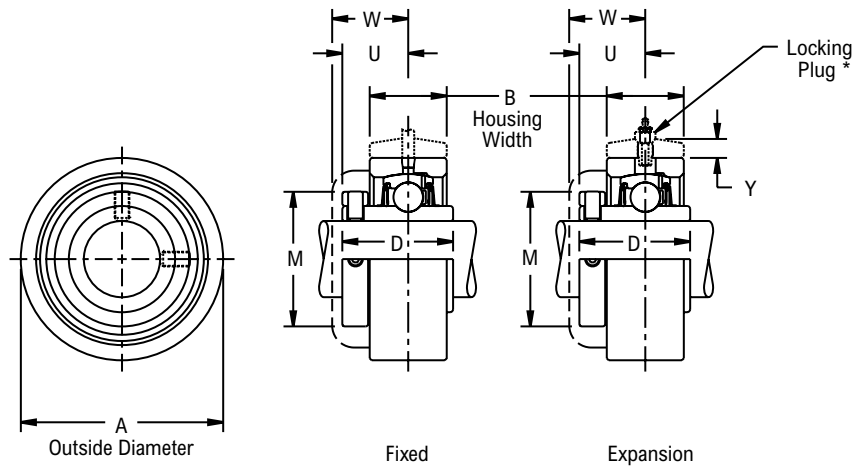
CU300, CEU300



Photo Shows a Ball Bearing Cartridge Unit with Steel Housing

Product Features

- Steel housing
- Spring locking setscrew mount
- Fixed or Expansion - Up to 11/32 in expansion
- Alignable & relubricatable
- See Features and Benefits for additional info on page 424.



Bearing Dimensions

Size Code	Shaft Diameter	Expansion	Fixed	A O.D.	B Cartridge Housing Width	D	M	U	W	Y	Total Axial Expansion	Approx. Weight
		Part Number	Part Number									
312	3/4	CEU312	CU312	2.4690	1 5/32	1 15/32	1 5/8	27/32	1 3/64	3/8	3/16	1.20
	7/8	CEU314	CU314									
316	15/16	CEU315	CU315	3.0000	1 1/4	1 43/64	2	63/64	1 15/64	3/8	3/16	2.00
	1	CEU316	CU316									
319	1 1/8	CEU318	CU318	3.4380	1 3/8	1 59/64	2 5/16	1 9/64	1 13/32	13/32	3/16	2.70
	1 3/16	CEU319	CU319									
323	1 1/4	CEU320	CU320	3.7500	1 1/2	2 3/32	2 9/16	1 1/4	1 1/2	9/16	3/16	3.50
	1 3/8	CEU322	CU322									
324	1 7/16	CEU323	CU323	4.1880	1 21/32	2 5/16	3 1/16	1 25/64	1 39/64	9/16	3/16	5.00
	1 1/2	CEU324	CU324									
328	1 5/8	CEU326	CU326	4.5940	1 27/32	2 19/32	3 1/4	1 35/64	1 27/32	9/16	3/16	6.50
	1 11/16	CEU327	CU327									
331	1 3/4	CEU328	CU328	5.0000	2 1/32	2 13/16	3 7/16	1 43/64	1 31/32	19/32	1/4	7.70
	1 15/16	CEU331	CU331									
335	2	CEU332	CU332	5.3750	2 3/16	3 1/16	3 15/16	1 27/32	2 3/16	11/16	9/32	9.70
	2 1/8	CEU334	CU334									
339	2 3/16	CEU335	CU335	5.7810	2 3/8	3 5/16	4 3/16	1 15/16	2 7/16	23/32	9/32	12.00
	2 1/4	CEU336	CU336									
344	2 7/16	CEU339	CU339	6.5620	2 3/4	3 13/16	4 3/4	2 1/4	2 5/8	13/16	7/32	17.00
	2 11/16	CEU343	CU343									
347	2 3/4	CEU344	CU344	6.9690	3	4 3/32	4 15/16	2 3/8	2 3/4	13/16	7/32	19.70
	2 15/16	CEU347	CU347									
351	3	CEU348	CU348	7.5940	3 3/16	4 13/32	5 11/16	2 19/32	3	1	11/32	26.90
	3 3/16	CEU351	CU351									
356	3 7/16	CEU355	CU355	8.3750	3 9/16	4 15/16	6	2 29/32	3 9/32	1	11/32	35.50
	3 1/2	CEU356	CU356									
363	3 15/16	CEU363	CU363	9.3750	4 1/16	5 9/16	7	3 9/32	3 11/16	1	11/32	49.50

Additional Notes

- Please call 1-866-REXNORD for availability
- Lubrication fitting tap size: for expansion units with shaft sizes 2 7/16 in and below, 1/4 in-28 UNF; for other expansion units and all fixed units, 1/8 in PT
- O.D. tolerance, +.000 in/- .002 in (+0.00 mm/-0.05 mm)
- Bore tolerance for mounting, +.002 in/- .000 in (+0.05 mm/-0.00 mm)
- 1 1/8 in thru 1 7/16 in & 1 5/8 in thru 2 15/16 in shaft sizes also available with dual contact lip seals, add suffix N

Locking plug thread sizes: for shaft sizes 2 7/16 in and below, 7/16 in-20 UNF; for all other shaft sizes, 5/8 in-18 UNF

For the Selection Guide, Load Ratings and Speed Limits, see the Link-Belt 300 Series Heavy Duty Ball Bearings Engineering section on pages 426 - 429.

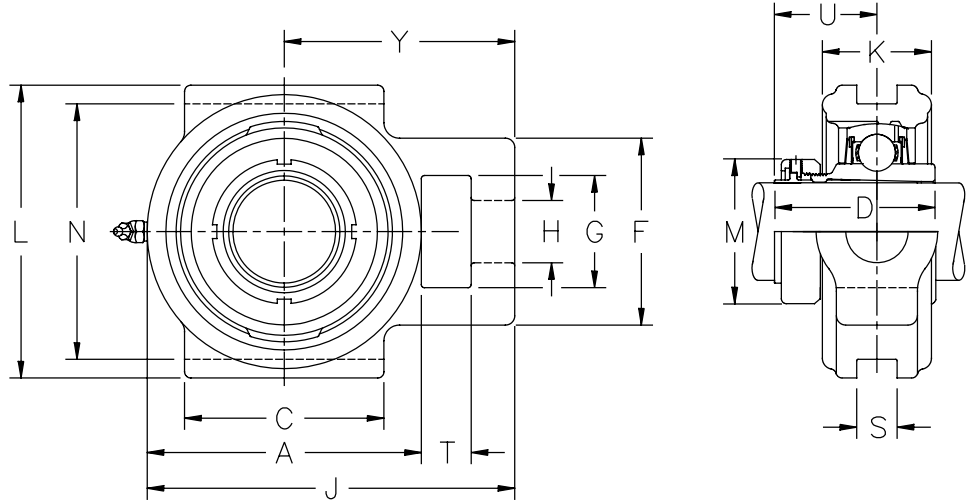
Note: Dimensions subject to change. Certified dimensions of ordered material furnished on request.



Photo Shows a Ball Bearing Take-Up Unit

Product Features

- Spyglass Optical Strain Sensor (OSS) Technology
- Positive locking system
- Tapered adapter sleeve
- Corrosion-resistant powder coating
- Cast iron housing
- Fixed or Expansion - up to 3/8 in. Expansion
- Alignable & relubricatable
- See Features and Benefits for additional info on page 424.



Bearing Dimensions

Size Code	Shaft Diameter	Part Number	H Adjusting Screw Hole Diameter	N Slot Spacing	S Slot Width	A	C	D	F	G	J	K	L	M	T	U	Y	Approx. Weight
323	1 7/16	TA323	7/8	3.500	0.531	4	2 3/4	2 47/64	2 3/8	1 7/16	5 1/4	1 5/8	4 1/8	2 3/8	5/8	1 29/32	3 1/4	5.00 lb
331	1 15/16	TA331	1 1/4	5.125	0.812	5 1/2	4	3 7/32	3 3/4	2 1/4	7 3/8	2 3/16	5 7/8	2 55/64	1	2 1/8	4 5/8	13.50 lb
335	2 3/16	TA335	1 1/4	5.500	0.812	5 13/16	4 1/8	3 23/64	3 3/4	2 1/4	7 3/4	2 3/8	6 1/4	3 15/64	1	2 9/64	4 27/32	16.00 lb
339	2 7/16	TA339	1 3/8	6.000	1.062	6 1/4	4 1/2	3 27/32	4 1/8	2 1/2	8 5/8	2 9/16	6 3/4	3 19/32	1 3/8	2 25/64	5 7/16	20.00 lb
347	2 15/16	TA347	1 5/8	7.500	1.312	8	5 3/4	4 17/32	4 3/4	2 3/4	10 1/2	3 1/4	8 1/4	4 3/32	1 1/4	2 51/64	6 1/2	38.00 lb

Additional Notes

- Please call 1-866-REXNORD for availability
- Lubrication fitting tap size, 1/8 in PT
- Take-up slot spacing & width tolerance, +.000 in/-0.015 in (+0.00 mm/-0.38 mm)
- 1 1/8 in thru 1 7/16 in & 1 5/8 in thru 2 15/16 in shaft sizes also available with dual contact lip seals, add suffix N
- For the Selection Guide, Load Ratings and Speed Limits, see the Link-Belt 300 Series Heavy Duty Ball Bearings Engineering section on pages 426 - 429.
- Note: Dimensions subject to change. Certified dimensions of ordered material furnished on request.

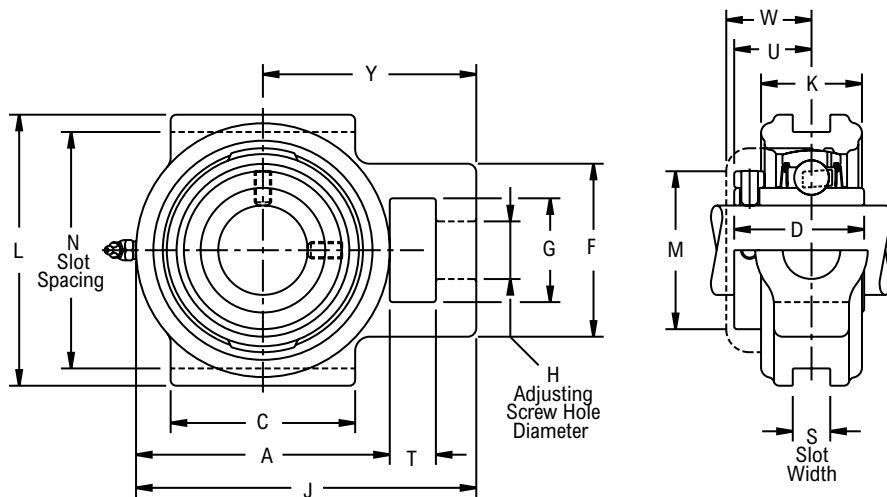
TU300



Photo Shows a Ball Bearing Take-Up Unit

Product Features

- Corrosion-resistant powder coating
- Cast iron housing
- Spring locking setscrew mount
- Alignable & relubricatable
- Machined slots
- See Features and Benefits for additional info on page 424.



Bearing Dimensions

Size Code	Shaft Diameter	Part Number	H Adjusting Screw Hole Diameter	N Slot Spacing	S Slot Width	A	C	D	F	G	J	K	L	M	T	U	W	Y	Approx. Weight
316	7/8	TU314	3/4	3.000	0.531	3 5/16	2 1/4	1 43/64	2	1 1/4	4 3/8	1 3/8	3 5/8	2	5/8	63/64	1 15/64	2 3/4	3.20
	15/16	TU315																	
	1	TU316																	
323	1 1/4	TU320	7/8	3.500	0.531	4	2 3/4	2 3/32	2 3/8	1 7/16	5 1/4	1 5/8	4 1/8	2 9/16	5/8	1 1/4	1 1/2	3 1/4	5.50
	1 3/8	TU322																	
	1 7/16	TU323																	
324	1 1/2	TU324	1 1/8	4.125	0.687	4 5/8	3 1/4	2 5/16	3 3/16	1 15/16	6 1/8	1 25/32	4 7/8	3 1/16	3/4	1 25/64	1 39/64	3 13/16	8.50
331	1 15/16	TU331	1 1/4	5.125	0.812	5 1/2	4	2 13/16	3 3/4	2 1/4	7 3/8	2 3/16	5 7/8	3 7/16	1	1 43/64	1 31/32	4 5/8	13.70
	2	TU332																	
	2 1/8	TU334																	
335	2 3/16	TU335	1 1/4	5.500	0.812	5 13/16	4 1/8	3 1/16	3 3/4	2 1/4	7 3/4	2 3/8	6 1/4	3 15/16	1	1 27/32	2 3/16	4 27/32	17.20
	2 1/4	TU336																	
339	2 7/16	TU339	1 3/8	6.000	1.062	6 1/4	4 1/2	3 5/16	4 1/8	2 1/2	8 5/8	2 9/16	6 3/4	4 3/16	1 3/8	1 15/16	2 7/16	5 7/16	20.00
	2 15/16	TU347																	
347	2 15/16	TU347	1 5/8	7.500	1.312	8	5 3/4	4 3/32	4 3/4	2 3/4	10 1/2	3 1/4	8 1/4	4 15/16	1 1/4	2 3/8	2 3/4	6 1/2	37.50

Additional Notes

- Please call 1-866-REXNORD for availability
- Lubrication fitting tap size, 1/8 in PT
- Take-up slot spacing & width tolerance, +.000 in/-.015 in (+0.00 mm/-0.38 mm)
- 1 1/8 in thru 1 7/16 in & 1 5/8 in thru 2 15/16 in shaft sizes also available with dual contact lip seals, add suffix N
- For the Selection Guide, Load Ratings and Speed Limits, see the Link-Belt 300 Series Heavy Duty Ball Bearings Engineering section on pages 426 - 429.
- Note: Dimensions subject to change. Certified dimensions of ordered material furnished on request.

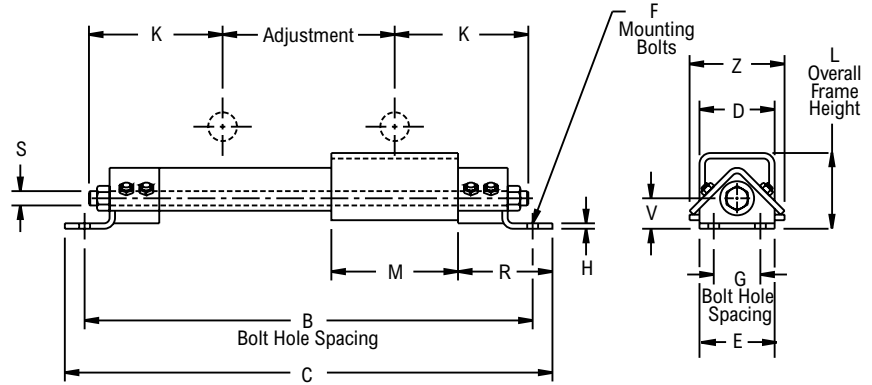
LHD FRAME



Photo Shows a Protected Screw Type Frame

Product Features

- Protected screw type frame
- Welded steel frame



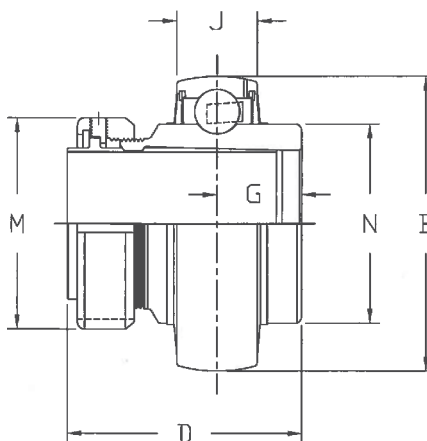
Bearing Dimensions

Size Code	Shaft Size	Part Number	Adjustment Length	B Bolt Hole Spacing	G Bolt Hole Spacing in Width Direction	L Overall Frame Height	C	D	E	F	H	K	M	R	S	V	Z	Approx. Weight
LHD20	7/8-1 15/16	LHD2012	12	29	2 1/2	5 1/4	31	4	5	5/8	1/4	8 1/2	11	4	3/4	2	6 1/4	48.00
		LHD2018	18	35			37											52.00
		LHD2024	24	41			43											56.00
		LHD2030	30	47			49											65.00
		LHD2036	36	53			55											70.00
		LHD2048	48	65			67											81.00
LHD25	2-2 3/16	LHD2512	12	32 3/4	3	6 1/4	35 1/4	5	5 1/2	5/8	3/8	10 3/8	13 1/4	5	1	2 9/16	7 1/8	81.00
		LHD2518	18	38 3/4			41 1/4											100.00
		LHD2524	24	44 3/4			47 1/4											110.00
		LHD2530	30	50 3/4			53 1/4											115.00
		LHD2536	36	56 3/4			59 1/4											120.00
		LHD2548	48	68 3/4			71 1/4											127.00
LHD30	2 1/4-2 7/16	LHD3012	12	35 1/2	3	7	38 1/4	6	6 1/2	3/4	1/2	11 3/4	14 1/4	6	1	2 1/2	9	158.00
		LHD3018	18	41 1/2			44 1/4											162.00
		LHD3024	24	47 1/2			50 1/4											166.00
		LHD3030	30	53 1/2			56 1/4											173.00
		LHD3036	36	59 1/2			62 1/4											183.00
		LHD3048	48	71 1/2			74 1/4											214.00
LHD35	2 11/16-3 3/16	LHD3512	12	37 1/4	3	7	40	6	6 1/2	3/4	1/2	12 5/8	16	6	1 1/4	2 1/2	9	173.00
		LHD3518	18	43 1/4			46											190.00
		LHD3524	24	49 1/4			52											195.00
		LHD3530	30	55 1/4			58											200.00
		LHD3536	36	61 1/4			64											210.00
		LHD3548	48	73 1/4			76											234.00
LHD40	3 7/16-3 15/16	LHD4012	12	41 1/4	3	7	44	7	6 1/2	3/4	1/2	14 5/8	20	6	1 1/2	2 1/2	9 13/16	175.00
		LHD4018	18	47 1/4			50											220.00
		LHD4024	24	53 1/4			56											265.00
		LHD4030	30	59 1/4			62											270.00
		LHD4036	36	65 1/4			68											290.00
		LHD4048	48	77 1/4			80											300.00

Additional Notes

- Please call 1-866-REXNORD for availability
- Note: Dimensions subject to change. Certified dimensions of ordered material furnished on request.

AG300L



Product Features

- Spyglass Optical Strain Sensor (OSS) Technology
 - Positive locking system
 - Tapered adapter sleeve
 - Enhanced life mounting style
 - Sealed & relubricatable
 - Alignable spherical O.D.
- See Features and Benefits for additional info on page 424.

Bearing Dimensions

Size Code	Shaft Diameter	Part Number	B O.D.	J Outer Ring Width	D	G	M	N	Approx. Weight
319	1 ³ / ₁₆	AG319L	2.8346	0.9449	2 ³ / ₄	²⁵ / ₃₂	2 ⁵ / ₃₂	1.708	1.50
323	1 ⁷ / ₁₆	AG323L	3.1496	1.0236	2 ⁴⁷ / ₆₄	²⁷ / ₃₂	2 ³ / ₈	1.946	1.90
328	1 ¹¹ / ₁₆	AG327L	3.937	1.1811	3 ¹ / ₈	⁵⁹ / ₆₄	2 ⁴¹ / ₆₄	2.443	3.80
331	1 ¹⁵ / ₁₆	AG331L	4.3307	1.2598	3 ⁷ / ₃₂	1 ⁹ / ₆₄	2 ⁵⁵ / ₆₄	2.701	5.00
335	2 ³ / ₁₆	AG335L	4.7244	1.3386	3 ²³ / ₆₄	1 ⁷ / ₃₂	3 ¹⁵ / ₆₄	2.959	6.00
339	2 ⁷ / ₁₆	AG339L	5.1181	1.4173	3 ²⁷ / ₃₂	1 ³ / ₈	3 ¹⁹ / ₃₂	3.216	7.50
344	2 ¹¹ / ₁₆	AG343L	5.9055	1.6142	4 ¹ / ₄	1 ⁹ / ₁₆	4 ³ / ₃₂	3.732	11.50
	2 ³ / ₄	AG344L							
347	2 ¹⁵ / ₁₆	AG347L	6.2992	1.6929	4 ¹⁷ / ₃₂	1 ²³ / ₃₂	4 ³ / ₃₂	3.990	13.00
351	3 ³ / ₁₆	AG351L	6.6929	1.7717	5 ¹ / ₂	1 ¹³ / ₁₆	4 ⁶¹ / ₆₄	4.247	17.00
356	3 ⁷ / ₁₆	AG355L	7.4806	1.9291	5 ²³ / ₆₄	2 ¹ / ₃₂	4 ⁶¹ / ₆₄	4.763	23.50
363	3 ¹⁵ / ₁₆	AG363L	8.4646	2.1654	5 ²⁹ / ₃₂	2 ⁹ / ₃₂	5 ⁴³ / ₆₄	5.339	33.00

Additional Notes

- Please call 1-866-REXNORD for availability
- 1 11/16 in thru 2 7/16 in shaft sizes also available with dual contact lip seals, add suffix N
- For the Selection Guide, Load Ratings and Speed Limits, see the Link-Belt 300 Series Heavy Duty Ball Bearings Engineering section on pages 426 - 429.
- Note: Dimensions subject to change. Certified dimensions of ordered material furnished on request.

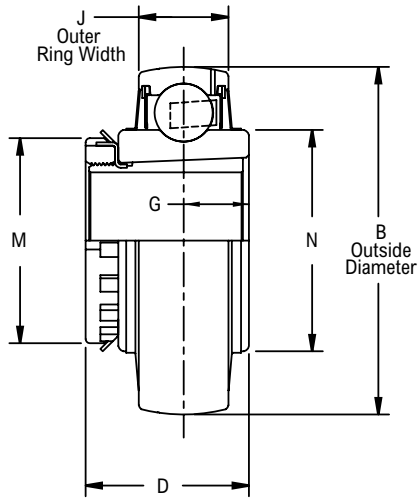
UG3K00L



Photo Shows an Unmounted Ball Bearing Unit

Product Features

- Enhanced life mounting style
- Sealed & relubricatable
- Alignable spherical O.D.
- See Features and Benefits for additional info on page 424.



Bearing Dimensions

Size Code	Shaft Diameter	Part Number	B O.D.	J Outer Ring Width	D	G	M	N	Approx. Weight
331	1 11/16	UG3K27L	4.3307	1.2598	2 19/32	31/32	2 11/16	2.702	5.70
335	1 15/16	UG3K31L	4.7244	1.3386	2 13/16	1	2 31/32	2.959	6.60
344	2 3/16	UG3K35L	5.9055	1.6142	3 1/16	1 3/16	3 3/8	3.732	11.50
347	2 7/16	UG3K39L	6.2992	1.6929	3 5/16	1 1/4	3 7/8	3.990	14.40
351	2 11/16	UG3K43L	6.6929	1.7717	3 13/16	1 5/16	4 5/32	4.247	21.50
356	2 15/16	UG3K47L	7.4806	1.9291	4 3/32	1 13/32	4 13/32	4.763	23.50
363	3 7/16	UG3K55L	8.4646	2.1654	4 15/16	1 9/16	5 3/16	5.339	33.00

Additional Notes

- Please call 1-866-REXNORD for availability
- 1 11/16 in thru 2 7/16 in shaft sizes also available with dual contact lip seals, add suffix N
- For the Selection Guide, Load Ratings and Speed Limits, see the Link-Belt 300 Series Heavy Duty Ball Bearings Engineering section on pages 426 - 429.
- Note: Dimensions subject to change. Certified dimensions of ordered material furnished on request.

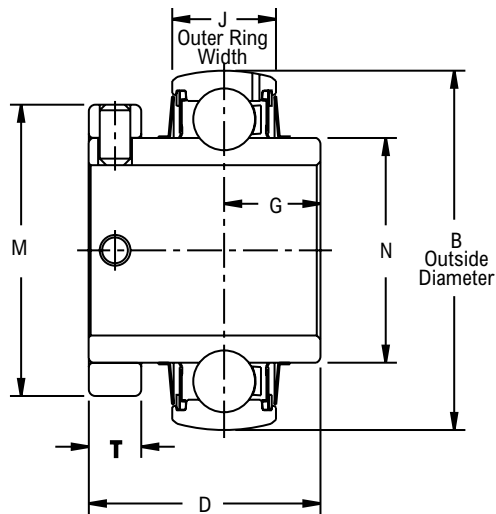
UG300L



Photo Shows an Unmounted Ball Bearing Unit

Product Features

- Spring locking setscrew mount
- Sealed & relubricatable
- Alignable spherical O.D.
- See Features and Benefits for additional info on page 424.



Bearing Dimensions

Size Code	Shaft Diameter	Part Number	B O.D.	J Outer Ring Width	D	G	M	N	T	Approx. Weight
312	3/4	UG312L	2.0472	0.7874	1 15/32	5/8	1 5/8	1.194	11/32	1.00
316	7/8	UG314L	2.4409	0.8661	1 43/64	11/16	2	1.451	13/32	1.50
	15/16	UG315L								
	1	UG316L								
319	1 1/8	UG318L	2.8346	0.9449	1 59/64	25/32	2 5/16	1.708	1/2	1.70
	1 3/16	UG319L								
323	1 1/4	UG320L	3.1496	1.0236	2 3/32	27/32	2 9/16	1.946	1/2	2.10
	1 3/8	UG322L								
	1 7/16	UG323L								
324	1 1/2	UG324L	3.5433	1.1024	2 5/16	59/64	3 1/16	2.204	9/16	2.90
	1 5/8	UG326L								
328	1 11/16	UG327L	3.9370	1.1811	2 19/32	1 3/4	3 1/2	2.443	5/8	3.95
	1 3/4	UG328L								
331	1 15/16	UG331L	4.3307	1.2598	2 13/16	1 9/64	3 7/16	2.701	21/32	4.70
	2	UG332L								
335	2 1/8	UG334L	4.7244	1.3386	3 1/16	1 7/32	3 15/16	2.959	3/4	6.60
	2 3/16	UG335L								
339	2 1/4	UG336L	5.1181	1.4173	3 5/16	1 3/8	4 3/16	3.216	3/4	7.95
	2 7/16	UG339L								
344	2 11/16	UG343L	5.9055	1.6142	3 13/16	1 9/16	4 3/4	3.732	7/8	11.50
	2 3/4	UG344L								
347	2 15/16	UG347L	6.2992	1.6929	4 3/32	1 23/32	4 15/16	3.990	7/8	13.00
351	3	UG348L	6.6929	1.7717	4 13/32	1 13/16	5 11/16	4.247	1	18.00
	3 3/16	UG351L								
356	3 7/16	UG355L	7.4806	1.9291	4 15/16	2 1/32	6	4.763	1 1/8	23.50
	3 1/2	UG356L								
363	3 15/16	UG363L	8.4646	2.1654	5 9/16	2 9/32	5.339	5.339	1 1/4	33.00

Additional Notes

Please call 1-866-REXNORD for availability

1 1/8 in thru 1 7/16 in & 1 5/8 in thru 2 15/16 in shaft sizes also available with dual contact lip seals, add suffix N

For the Selection Guide, Load Ratings and Speed Limits, see the Link-Belt 300 Series Heavy Duty Ball Bearings Engineering section on pages 426 - 429.

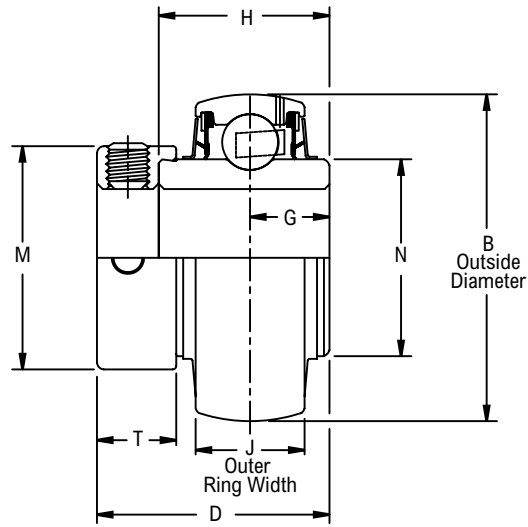
Note: Dimensions subject to change. Certified dimensions of ordered material furnished on request.



Photo Shows an Unmounted Ball Bearing Unit

Product Features

- Eccentric cam locking device
- Sealed & relubricatable
- Alignable spherical O.D.
- See Features and Benefits for additional info on page 424.



Bearing Dimensions

Size Code	Shaft Diameter	Part Number	B O.D.	J Outer Ring Width	D	G	H	M	N	T	Approx. Weight
319	1 3/16	YG319NL	2.8346	0.9449	2 1/32	25/32	1.48	1 15/16	1.708	11/16	1.70
323	1 7/16	YG323NL	3.1496	1.0236	2 5/32	27/32	1.62	2 3/16	1.946	11/16	2.10
328	1 11/16	YG327NL	3.9370	1.1811	2 9/16	1 3/64	1.94	2 3/4	2.443	13/16	3.95
331	1 15/16	YG331NL	4.3307	1.2598	2 25/32	1 9/64	2.08	3	2.701	7/8	4.70
335	2 3/16	YG335NL	4.7244	1.3386	2 15/16	1 7/32	2.24	3 1/4	2.959	7/8	6.60
339	2 7/16	YG339NL	5.1181	1.4173	3 5/32	1 3/8	2.47	3 1/2	3.216	15/16	7.95
344	2 11/16	YG343NL	5.9055	1.6142	3 9/16	1 9/16	2.74	4	3.732	1 1/16	11.50
347	2 15/16	YG347NL	6.2992	1.6929	3 15/16	1 23/32	2.93	4 7/16	3.990	1 1/4	13.00

Additional Notes

- Please call 1-866-REXNORD for availability
- N dual contact lip seals standard
- For the Selection Guide, Load Ratings and Speed Limits, see the Link-Belt 300 Series Heavy Duty Ball Bearings Engineering section on pages 426 - 429.
- Note: Dimensions subject to change. Certified dimensions of ordered material furnished on request.



SHURLOK Installation Tools

We are pleased to offer a quick installation tool for the SHURLOK bearing. This tool is designed as a supplement to the spanner wrench or drift pin method. The installation tool can be attached to a 3/4" or 1/2" drive ratchet, torque wrench, or breaker bar which can be used as a lever arm. Simply fit the installation tool over the locknut by placing the tool's teeth into the locknut slots. The tool's unique shape allows it to be used from the side or the top of the bearing. To order, refer to the table below for the installation tool that fits your shaft size.

Bearing Size	Wrench Style Installation Tool Part Number	Impact Style Installation Tool Part Number
323	N6107-SPN	N6107-IMP
327	N6111-SPN	N6111-IMP
331	105-90420-11	105-90425-11
335	105-90420-21	105-90425-21
339	105-90420-31	105-90425-31
343/344/347	105-90420-41	105-90425-41
351/355	105-90420-51	105-90425-51
363	105-90420-61	105-90425-61



Ball Bearings

Units: Klean-Gard & Dura-Klean



Contents

	Page
Features and Benefits	454
Nomenclature	455
Engineering	456
Dimensions	
Klean-Gard Pillow Blocks	459
Klean-Gard Flange Blocks	460
Dura-Klean Pillow Blocks	463
Dura-Klean Flange Blocks	465
Dura-Klean Take-up Blocks	468
Klean-Gard Accessory Kits	469

Industries Served

Food and Beverage



Klean-Gard & Dura-Klean Ball Bearings For Beverage & Food Conveying Applications

Klean-Gard

Available in polypropylene (white) housings with stainless steel inserts. Housing styles available in pillow blocks, 2-bolt, 3-bolt & 4-bolt flanges. Snap-on cap (open or closed) available. Solid-back housings are designed to inhibit the growth of bacteria, mold, and mildew that may cause discoloration, odor, or degradation.

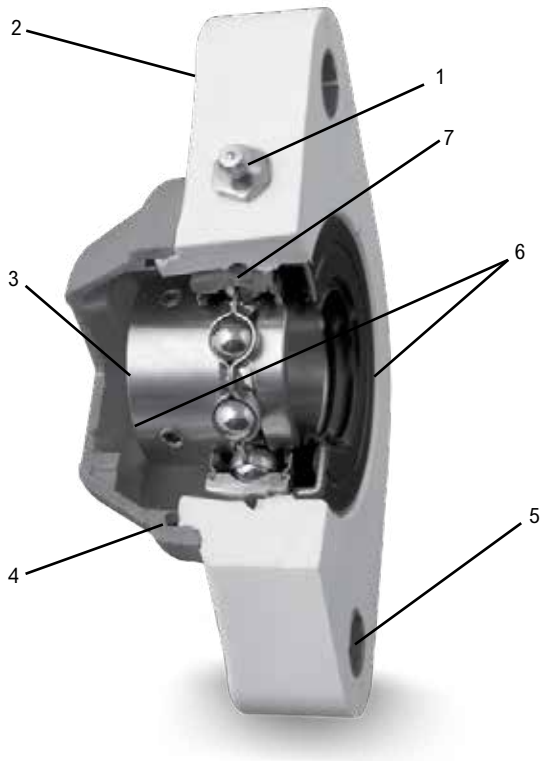
Always maintain good hygiene; proper cleaning procedures are still required.

Interchangeable with cast iron units. Beverage bearing configuration available upon request, add the prefix "W."

Dura-Klean

Rilsan nylon coated with black oxide inserts and food grade grease.

Available in pillow blocks, 2-bolt, 3-bolt & 4-bolt flanges and take-up units up to 1 15/16" bore size.



1. Corrosion Resistant Fittings for Relubrication

Bearing insert factory prelubricated with food-grade grease.

2. Reinforced Housing Material

Rugged, reinforced housing material available in Polypropylene (white) for extreme corrosion resistance.

3. Inch or Metric Shaft Sizes Available

4. Auxiliary Caps

Both open and closed auxiliary safety caps fit tightly to the machined housing and are sealed with heavy duty O-rings.

5. Stainless Steel Bushings and Washers

AISI 316 stainless steel spacer bushing and washer for trouble-free, positive mounting.

6. Rotary Shaft Seals

Front and rear auxiliary rotary shaft seals provided with spring loaded double lip seal to guard critical bearing components and prevent conveyor contamination.

7. Stainless Steel Ball Bearings

Alignable, high capacity, stainless steel ball bearing mounted with setscrews to the shaft. Integral bearing lip seals.



Klean-Gard Nomenclature

Symbol	Description	KL	FX	SS	2	E	20	DC	V
KL	Polypropylene (White) housing material	_____	_____	_____	_____	_____	_____	_____	_____
W	Beverage unit with water drainage features	_____	_____	_____	_____	_____	_____	_____	_____
F	Flanged unit, 4-bolt	_____	_____	_____	_____	_____	_____	_____	_____
FB	Flanged bracket unit, 3-bolt	_____	_____	_____	_____	_____	_____	_____	_____
FX	Flanged unit, 2-bolt	_____	_____	_____	_____	_____	_____	_____	_____
P	Pillow block, standard backing	_____	_____	_____	_____	_____	_____	_____	_____
SS	Extended inner ring, stainless steel insert, molded lip seals	_____	_____	_____	_____	_____	_____	_____	_____
2	Series 200 ball bearing designation	_____	_____	_____	_____	_____	_____	_____	_____
E	Inner ring bore equal to a bore of the next larger bearing group	_____	_____	_____	_____	_____	_____	_____	_____
20	Shaft size in sixteenths of an inch	_____	_____	_____	_____	_____	_____	_____	_____
M30	Shaft size in millimeters	_____	_____	_____	_____	_____	_____	_____	_____
None	Open end unit, basic unit	_____	_____	_____	_____	_____	_____	_____	_____
C	Closed end unit, no auxiliary seals	_____	_____	_____	_____	_____	_____	_____	_____
D	Open end unit, end cap with seal and rear auxiliary dual lip seal	_____	_____	_____	_____	_____	_____	_____	_____
DC	Closed end unit, end cap and rear auxiliary dual lip seal	_____	_____	_____	_____	_____	_____	_____	_____
V	Viton auxiliary seals	_____	_____	_____	_____	_____	_____	_____	_____
K4	100% Grease filled	_____	_____	_____	_____	_____	_____	_____	_____
K6	Lubed for Life	_____	_____	_____	_____	_____	_____	_____	_____

Dura-Klean Nomenclature

Symbol	Description	W	F	3	S	2	E	20	E
W	Dura-Klean (White) housing	_____	_____	_____	_____	_____	_____	_____	_____
F	Flanged unit, 3 and 4-bolt	_____	_____	_____	_____	_____	_____	_____	_____
FB	Flanged bracket unit, 3-bolt	_____	_____	_____	_____	_____	_____	_____	_____
FX	Flanged unit, 2-bolt	_____	_____	_____	_____	_____	_____	_____	_____
P	Pillow block, standard backing	_____	_____	_____	_____	_____	_____	_____	_____
PT	Pillow block, tapped base	_____	_____	_____	_____	_____	_____	_____	_____
TH	Take-up, wide slot	_____	_____	_____	_____	_____	_____	_____	_____
3	Integral bearing seals	_____	_____	_____	_____	_____	_____	_____	_____
S	Extended inner ring, spring locking, black oxide coated rings	_____	_____	_____	_____	_____	_____	_____	_____
2	Series 200 ball bearing designation	_____	_____	_____	_____	_____	_____	_____	_____
E	Inner ring bore equal to a bore of the next larger bearing group	_____	_____	_____	_____	_____	_____	_____	_____
20	Shaft size in sixteenths of an inch	_____	_____	_____	_____	_____	_____	_____	_____
M30	Shaft size in millimeters	_____	_____	_____	_____	_____	_____	_____	_____
E	Molded single lip seals	_____	_____	_____	_____	_____	_____	_____	_____
K4	100% Grease filled	_____	_____	_____	_____	_____	_____	_____	_____
K6	100% Grease filled and housing plugged	_____	_____	_____	_____	_____	_____	_____	_____

Klean-Gard & Dura-Klean Ball Bearings Selection Guide

To select a bearing, determine the applied radial load, the applied thrust load, the desired Rating Life, and applicable operating conditions. The procedure shown here will aid in selecting a bearing to meet an L₁₀ design life. The formulas for calculating life expectancy should be used to determine the Rating Life L₁₀ for the bearing selected.

The selection procedures and rating formulas shown here are in agreement with The American Bearing Manufacturers Association Standards and ANSI/ABMA Standards STD 9-1990. Ratings are based on fatigue life. The Rating Life or fatiguelife at 90% reliability is the usual basis for bearing selection.

Steps for Selection

Step 1

Determine an appropriate L₁₀ design life.

Type of service	Operating time, hours per year	Design life, years	L ₁₀ design life, hours
Light seasonal usage	500 to 750	3-5	3,000
Heavy seasonal usage	1,400 to 1,600	4-6	8,000
Industrial—8 hour shift	2,000	10	20,000

Step 2

Determine a required $\left(\frac{C}{P}\right)$ from Table 1.

Step 3

Calculate the required C and select a ball bearing.

a For radial load only:

$$P = F_r$$

$$\text{required } C = \left(\frac{C}{P}\right)P \text{ using } \left(\frac{C}{P}\right) \text{ from Step 2}$$

Select a ball bearing from Table 3 with a basic load rating C equal to or greater than the required C.

b For combined radial and thrust loads when $\frac{F_a}{F_r}$ is 0.19 or less:

$$P = F_r$$

$$\text{required } C = \left(\frac{C}{P}\right)P \text{ using } \left(\frac{C}{P}\right) \text{ from Step 2}$$

Select a ball bearing from Table 3 with a basic load rating C equal to or greater than the required C.

Series S200 and SS200 are extended on one side only for compactness and low cost. In combination with its companion line of economically designed housings, this series is applicable to light or moderate duty requirements. Also, economically designed housings must be applied within proportionate load limits.

To assure a satisfactory bearing application, fitting practice, mounting, lubrication, sealing, static rating, housing strength, operating conditions and maintenance must be considered.

Step 3 (continued)

c For combined radial and thrust loads when $\frac{F_a}{F_r}$ is greater than 0.19, use the following trial method:

$$\text{Maximum } P = .56F_r + 2.30F_a$$

$$\text{Maximum required } C = \left(\frac{C}{P}\right)P \text{ using } \left(\frac{C}{P}\right) \text{ from Step 2}$$

Select a trial ball bearing with a basic load rating C from Table 3 approximately equal to the maximum required C.

With this trial bearing calculate: $\frac{F_a}{Nd^2}$

Determine X and Y from Table 2.

Calculate P for the trial bearing.

$$P = XF_r + YF_a$$

$$\text{required } C = \left(\frac{C}{P}\right)P \text{ for the trial bearing using } \left(\frac{C}{P}\right) \text{ from Step 2}$$

Consult Table 3, basic load rating. If a smaller bearing meets or nearly meets the required C, its life expectancy can be calculated.

Note: If the load P is greater than .15C for series S200 and SS200, consult Rexnord Bearing Products.

Selection

Symbols for formulas:

C = basic load rating, pounds (or newtons)	n = speed, revolutions per minute
Co = static load rating, pounds (or newtons)	P = equivalent radial load, pounds (or newtons)
e = a reference value	X = radial factor
Fa = thrust load, pounds (or newtons)	Y = thrust factor
Fr = radial load, pounds (or newtons)	
L10 = rating life, hours	

Table 1 • Relation of L10 life and speed to $\left(\frac{C}{P}\right)$

Bearing life, hours L10	$\left(\frac{C}{P}\right)$ ratio									
	Speed, n									
	50	100	200	300	400	500	600	700	800	
3000	2.08	2.62	3.30	3.77	4.15	4.47	4.75	5.01	5.23	
4000	2.29	2.88	3.63	4.15	4.57	4.92	5.23	5.51	5.76	
5000	2.46	3.10	3.91	4.47	4.92	5.30	5.64	5.93	6.20	
6000	2.62	3.30	4.15	4.75	5.23	5.64	5.99	6.30	6.59	
8000	2.88	3.63	4.57	5.23	5.76	6.20	6.59	6.94	7.25	
10000	3.10	3.91	4.92	5.64	6.20	6.68	7.10	7.47	7.81	
12000	3.30	4.15	5.23	5.99	6.59	7.10	7.54	7.94	8.30	
14000	3.47	4.37	5.51	6.30	6.94	7.47	7.94	8.36	8.74	
16000	3.63	4.57	5.76	6.59	7.25	7.81	8.30	8.74	9.14	
18000	3.77	4.75	5.99	6.86	7.54	8.13	8.63	9.09	9.50	
20000	3.91	4.92	6.20	7.10	7.81	8.42	8.94	9.41	9.84	
25000	4.21	5.30	6.68	7.65	8.42	9.07	9.63	10.1	10.6	
30000	4.47	5.64	7.10	8.13	8.94	9.63	10.2	10.8	11.3	
35000	4.71	5.93	7.47	8.55	9.41	10.1	10.8	11.3	11.9	
40000	4.92	6.20	7.81	8.94	9.84	10.6	11.3	11.9	12.4	
45000	5.12	6.45	8.13	9.30	10.2	11.0	11.7	12.3	12.9	
50000	5.30	6.68	8.42	9.63	10.6	11.4	12.1	12.8	13.4	
60000	5.64	7.10	8.94	10.2	11.3	12.1	12.9	13.6	14.2	
70000	5.93	7.47	9.41	10.8	11.9	12.8	13.6	14.3	14.9	
80000	6.20	7.81	9.84	11.3	12.4	13.4	14.2	14.9	15.6	
90000	6.45	8.13	10.2	11.7	12.9	13.9	14.8	15.5	16.2	
100000	6.68	8.42	10.6	12.1	13.4	14.4	15.3	16.1	16.8	
150000	7.65	9.63	12.1	13.9	15.3	16.5	17.5	18.4	19.3	
200000	8.42	10.6	13.4	15.3	16.8	18.1	19.3	20.3	21.2	

Bearing life, hours L10	Speed, n									
	900	1000	1200	1500	1800	2400	3600	6000	10000	
	3000	5.44	5.64	5.99	6.45	6.86	7.54	8.63	10.2	12.1
4000	5.99	6.20	6.59	7.10	7.54	8.30	9.50	11.3	13.4	
5000	6.45	6.68	7.10	7.65	8.13	8.94	10.2	12.1	14.4	
6000	6.86	7.10	7.54	8.13	8.63	9.50	10.9	12.9	15.3	
8000	7.54	7.81	8.30	8.94	9.50	10.5	12.0	14.2	16.8	
10000	8.13	8.42	8.94	9.63	10.2	11.3	12.9	15.3	18.1	
12000	8.63	8.94	9.50	10.2	10.9	12.0	13.7	16.2	19.3	
14000	9.09	9.41	10.0	10.8	11.4	12.6	14.4	17.1	20.3	
16000	9.50	9.84	10.5	11.3	12.0	13.2	15.1	17.9	21.2	
18000	9.88	10.2	10.9	11.7	12.4	13.7	15.7	18.6	22.0	
20000	10.2	10.6	11.3	12.1	12.9	14.2	16.2	19.3	22.8	
25000	11.0	11.4	12.1	13.1	13.9	15.3	17.5	20.7	24.6	
30000	11.7	12.1	12.9	13.9	14.8	16.2	18.6	22.0	26.1	
35000	12.3	12.8	13.6	14.6	15.5	17.1	19.6	23.2	27.5	
40000	12.9	13.4	14.2	15.3	16.2	17.9	20.5	24.3	28.7	
45000	13.4	13.9	14.8	15.9	16.9	18.6	21.3	25.2	29.9	
50000	13.9	14.4	15.3	16.5	17.5	19.3	22.0	26.1	31.0	
60000	14.8	15.3	16.2	17.5	18.6	20.5	23.4	27.8	32.9	
70000	15.5	16.1	17.1	18.4	19.6	21.5	24.6	29.2	34.6	
80000	16.2	16.8	17.9	19.3	20.5	22.5	25.8	30.5	36.2	
90000	16.9	17.5	18.6	20.0	21.3	23.4	26.8	31.8	37.7	
100000	17.5	18.1	19.3	20.7	22.0	24.3	27.8	32.9	39.0	
150000	20.0	20.7	22.0	23.7	25.2	27.8	31.8	37.7	44.6	
200000	22.0	22.8	24.3	26.1	27.8	30.5	35.0	41.4	49.1	

Basic formula

$$\left(\frac{C}{P}\right) = \left(\frac{L_{10} \times n \times 60}{1,000,000}\right)^{1/3}$$

$$L_{10} = \frac{\left(\frac{C}{P}\right)^3}{n \times 60} \times 1,000,000$$

Life Expectancy

To calculate the Rating Life L10 of any selected or trial bearing:

Step 1 Determine the equivalent radial load P.

- a For radial load only:
P = Fr
- b For combined radial and thrust load:
P = XFr + YFa using X and Y from Table 2 below.

Step 2 Calculate the ratio of basic load rating C to the equivalent radial load.

$$\left(\frac{C}{P}\right)$$

Step 3 Approximate the bearing life from Table 1.

Table 2 • X and Y factors for ball bearings

Fa Nd ²	e	Fa Fr ≤ e		Fa Fr > e	
		X	Y	X	Y
25	.19	1.0	0	.56	2.30
37.5	.21	1.0	0	.56	2.15
50	.22	1.0	0	.56	1.99
75	.24	1.0	0	.56	1.85
100	.26	1.0	0	.56	1.71
125	.27	1.0	0	.56	1.63
150	.28	1.0	0	.56	1.56
200	.30	1.0	0	.56	1.45
300	.34	1.0	0	.56	1.31
500	.38	1.0	0	.56	1.15
750	.42	1.0	0	.56	1.04
1000	.44	1.0	0	.56	1.00

For values between those in the table linear interpolation can be used.

Life Adjustment

The Rating Life, L10, may be modified for some applications in accordance with the formula

$$L_n = a_1 a_2 a_3 L_{10}$$

where L_n = Adjusted life for (100-n) % reliability,

a₁ = Life adjustment factor for reliability

a₂ = Life adjustment factor for material and processing

a₃ = Life adjustment factor for operating conditions.

For most normal applications, all factors will be taken as 1, and the Rating Life used as the selection basis or life estimate. In addition, as long as standard catalog bearings are used, a₂ will be normally set equal to one. The factor a₃ covers such things as lubrication, misalignment, and temperature. Some conditions that could yield a₃ significantly different than unity include speeds less than 20000 DN or greater than 200000 DN, temperatures below -40°F (-40°C) or above 275°F (135°C). For other possible conditions, as well as additional information on life adjustment factors, consult Rexnord Bearing Products.

Table 3 • Load ratings, speed limits and ball data

Size Code	C Basic Load Rating		Co Static Load Rating		Approximate Speed Limit RPM*	d Ball diameter inches	N Number of balls	Nd ²
	pounds	newtons	pounds	newtons				
204	2870	12,800	1480	6,590	7500	5/16	8	.781
205	3150	14,000	1760	7,830	6800	5/16	9	.879
206	4390	19,500	2530	11,300	5600	3/8	9	1.27
207	5810	25,800	3440	15,300	4800	7/16	9	1.72
208	7330	32,600	4460	19,900	4500	1/2	9	2.25
209	7370	32,800	4590	20,400	4000	1/2	9	2.25
210	7920	35,200	5220	23,200	3600	1/2	10	2.50

If the load P is greater than 15% of C rating for S200 and SS200, consult Rexnord Bearing Products.

For S200 and SS200 Series, reduce C Basic Load Rating by 23%.

*Based on grease lubrication and moderate load.

Table 4 • Radial load ratings in pounds at various RPM for appropriate L10 life hours

Size Code	L10 Minimum life, hours	Radial Load Ratings, Pounds/Speed, RPM																			
		50	100	200	300	400	500	600	700	800	900	1000	1200	1500	1800	2000	2500	3000	3500	4000	5000
204	8000	996	791	627	548	498	462	435	413	395	380	367	345	321	302	291	270	254	242	231	215
	20000	734	582	462	404	367	341	321	304	291	280	270	254	236	222	215	199	187	178	170	158
	40000	582	462	367	321	291	270	254	242	231	222	215	202	187	176	170	158	149	141	135	125
	100000	429	341	270	236	215	199	187	178	170	164	158	149	138	130	125	116	110	104	100	92
205	8000	1095	869	690	603	548	508	478	454	435	418	403	380	352	332	320	297	280	266	254	236
	20000	807	640	508	444	403	375	352	335	320	308	297	280	260	244	236	219	206	196	187	174
	40000	640	508	403	352	320	297	280	266	254	244	236	222	206	194	187	174	164	155	149	138
	100000	472	375	297	260	236	219	206	196	187	180	174	164	152	143	138	128	121	115	110	102
206	8000	1523	1209	960	838	762	707	665	632	605	581	561	528	490	461	445	413	389	370	354	328
	20000	1122	891	707	618	561	521	490	466	445	428	413	389	361	340	328	305	287	272	260	242
	40000	891	707	561	490	445	413	389	370	354	340	328	309	287	270	260	242	228	216	207	192
	100000	656	521	413	361	328	305	287	272	260	250	242	228	211	199	192	178	168	159	152	141
207	8000	2015	1599	1269	1109	1007	935	880	836	799	769	742	698	648	610	589	547	515	489	468	434
	20000	1484	1178	935	817	742	689	648	616	589	566	547	515	478	450	434	403	379	360	344	320
	40000	1178	935	742	648	589	547	515	489	468	450	434	408	379	357	344	320	301	286	273	254
	100000	868	689	547	478	434	403	379	360	344	331	320	301	279	263	254	236	222	211	201	187
208	8000	2542	2017	1601	1399	1271	1180	1110	1055	1009	970	936	881	818	770	743	690	649	617	590	548
	20000	1873	1486	1180	1031	936	869	818	777	743	715	690	649	603	567	548	508	478	454	435	403
	40000	1486	1180	936	818	743	690	649	617	590	567	548	515	478	450	435	403	380	361	345	320
	100000	1095	869	690	603	548	508	478	454	435	418	403	380	352	332	320	297	280	266	254	236
209	8000	2555	2028	1610	1406	1278	1186	1116	1060	1014	975	941	886	822	774	747	694	653	620	593	551
	20000	1883	1494	1186	1036	941	874	822	781	747	718	694	653	606	570	551	511	481	457	437	406
	40000	1494	1186	941	822	747	694	653	620	593	570	551	518	481	453	437	406	382	363	347	322
	100000	1101	874	694	606	551	511	481	457	437	420	406	382	354	333	322	299	281	267	256	237
210	8000	2745	2178	1729	1510	1372	1274	1199	1139	1089	1047	1011	952	883	831	803	745	701	666	637	598
	20000	2022	1605	1274	1113	1011	939	883	839	803	772	745	701	651	612	591	549	517	491	469	437
	40000	1605	1274	1011	883	803	745	701	666	637	612	591	556	517	486	469	436	410	389	373	347
	100000	1183	939	745	651	591	549	517	491	469	451	436	410	381	358	346	321	302	287	274	254

Operation in the high speed shaded areas requires frequent relubrication.

Heavy lines define recommended speed ranges of bearing and seal variations.

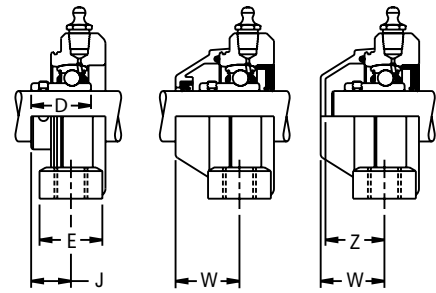
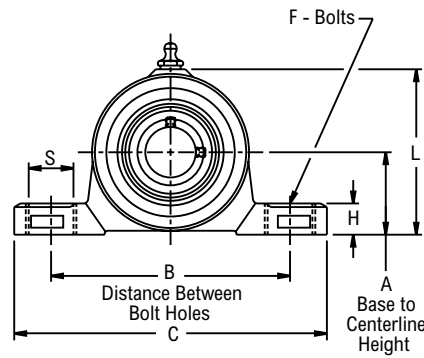
If the load P is greater than 15% of C rating for S200 and SS200, consult Rexnord Bearing Products.

KLPSS200

Interchange: P2BSCEZ, SUCP200-PBT, KAS



Photo Shows a 2-Bolt Ball Bearing Pillow Block Unit with Stainless Steel Insert and Polypropylene Housing



Basic Unit	Open Unit with Auxiliary Seals	Closed Unit with End Cap and Seal
KLP-SS200	KLP-SS200D	KLP-SS200DC

Product Features

- Reinforced Polypropylene housing
- Stainless steel bearing insert
- Stainless steel bushing & washers
- Alignable & relubricatable
- Spring locking setscrew mount
- Prelubricated with food grade grease
- See Features and Benefits for additional info on page 454.

Bearing Dimensions

Size Code	Shaft Diameter	Polypropylene		A Base to Centerline Height	B Distance Between Bolt Holes	C	D	E	F Bolts	H	J	L	S	W	Z	Approx. Weight
		Part Number														
204	3/4	KLPSS212		1 5/16	3 25/32	5 1/32	1 1/8	1 3/16	3/8	43/64	3/4	3 1/32	7/8	1 7/32	1 1/8	1.50
	20.00	KLPSS2M20		33.30	96.00	128.00	28.58	30.00	10.00	17.00	19.00	77.00	22.00	30.80	28.80	0.68
205	1	KLPSS216		1 7/16	4 11/64	5 31/64	1 3/16	1 23/64	3/8	43/64	13/16	3 11/32	7/8	1 9/32	1 13/64	1.80
	25.00	KLPSS2M25		36.50	106.00	140.00	30.17	34.50	10.00	17.00	20.60	85.00	22.00	32.70	30.70	0.80
206	1 3/16	KLPSS219		1 11/16	4 49/64	6 27/64	1 11/32	1 27/64	1/2	25/32	61/64	3 55/64	15/16	1 3/8	1 19/64	1.80
	1 1/4	KLPSS2E20														
	30.00	KLPSS2M30		42.90	121.00	163.00	34.13	36.00	12.00	20.00	24.20	98.00	24.00	35.00	33.00	0.80
207	1 1/4	KLPSS220		1 7/8	4 31/32	6 37/64	1 9/16	1 33/64	1/2	25/32	1 7/64	4 1/4	15/16	1 9/16	1 15/32	2.00
	1 3/8	KLPSS222														
	35.00	KLPSS2M35														
208	1 1/2	KLPSS224		2	5 11/32	7 9/32	1 11/16	1 33/64	1/2	25/32	1 13/64	4 13/32	15/16	1 41/64	1 9/16	2.20
	40.00	KLPSS2M40														

Additional Notes

- Please call 1-866-REXNORD for availability
- Lubrication fitting tap size, Rp 1/8" parallel thread per ISO 7/1 latest revision
- Note: 1/8" PT external thread will not fit
- Polypropylene housings furnished with nitrile rubber seals, o-ring & AISI 316 stainless steel bushings and washers
- For the Selection Guide, Load Ratings and Speed Limits, see the Klean-Gard & Dura-Klean Ball Bearings Engineering section on pages 456 - 458.

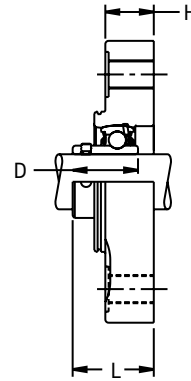
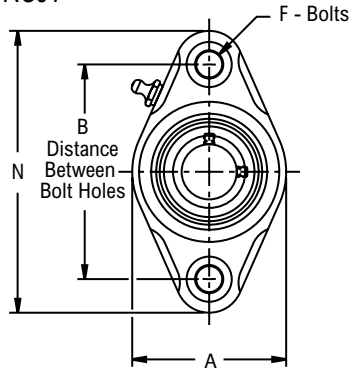
Note: Dimensions subject to change. Certified dimensions of ordered material furnished on request.

KLFXSS200

Interchange: F2BSCEZ, SUCFT200-PBT, KCJT



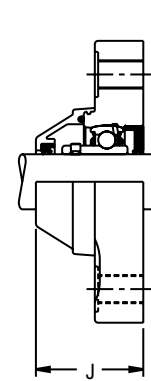
Photo Shows a 2-Bolt Ball Bearing Flanged Unit with Stainless Steel Insert and Polypropylene Housing



Mounting Surface to Inner Ring Hub Face

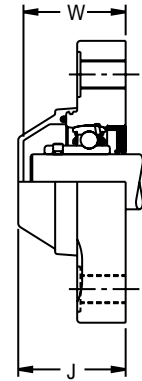
Basic Unit

KLFX-SS200



Open Unit with Auxiliary Seals

KLFX-SS200D



Closed Unit with End Cap and Seal

KLFX-SS200DC

Product Features

- Reinforced Polypropylene housing
- Stainless steel bearing insert
- Stainless steel bushing & washers
- Spring locking setscrew mount
- Alignable & relubricatable
- Prelubricated with food grade grease
- See Features and Benefits for additional info on page 454.

Bearing Dimensions

Size Code	Shaft Diameter	Polypropylene	B Distance Between Bolt Holes	L Mounting Surface to Inner Ring Hub Face	A	D	F Bolts	H	J	N	W	Approx. Weight
		Part Number										
204	$\frac{3}{4}$	KLFXSS212	3.54	$1\frac{23}{64}$	$2\frac{7}{16}$	$1\frac{1}{8}$	$\frac{7}{16}$	$\frac{51}{64}$	$1\frac{13}{16}$	$4\frac{9}{16}$	$1\frac{11}{16}$	0.90
	20.00	KLFXSS2M20	90.00	34.30	62.00	28.58	11.00	20.00	46.00	116.00	43.00	0.41
205	1	KLFXSS216	3.90	$1\frac{15}{32}$	$2\frac{13}{16}$	$1\frac{3}{16}$	$\frac{7}{16}$	$\frac{7}{8}$	$1\frac{57}{64}$	$5\frac{1}{8}$	$1\frac{7}{8}$	1.00
	25.00	KLFXSS2M25	99.00	37.30	71.00	30.17	11.00	22.50	49.50	130.00	47.50	0.45
206	$1\frac{3}{16}$	KLFXSS219	4.61	$1\frac{3}{4}$	$3\frac{11}{32}$	$1\frac{11}{32}$	$\frac{7}{16}$	$1\frac{1}{64}$	$2\frac{11}{64}$	$5\frac{53}{64}$	$2\frac{3}{32}$	1.25
	$1\frac{1}{4}$	KLFXSS2E20										
	30.00	KLFXSS2M30										
207	$1\frac{1}{4}$	KLFXSS220	5.12	$1\frac{7}{8}$	$3\frac{21}{32}$	$1\frac{9}{16}$	$\frac{7}{16}$	$1\frac{1}{64}$	$2\frac{21}{64}$	$6\frac{3}{8}$	$2\frac{1}{4}$	1.50
	$1\frac{3}{8}$	KLFXSS222										
	$1\frac{7}{16}$	KLFXSS223										
208	$1\frac{1}{2}$	KLFXSS224	5.67	$2\frac{1}{16}$	$4\frac{1}{64}$	$1\frac{11}{16}$	$\frac{7}{16}$	$1\frac{3}{16}$	$2\frac{37}{64}$	$6\frac{59}{64}$	$2\frac{15}{32}$	2.00
	40.00	KLFXSS2M40	144.00	52.40	102.00	42.87	11.00	30.00	65.50	176.00	62.50	0.90

Additional Notes

- Please call 1-866-REXNORD for availability
- Lubrication fitting tap size, Rp $1/8"$ parallel thread per ISO 7/1 latest revision
- Note: $1/8"$ PT external thread will not fit
- Polypropylene housings furnished with nitrile rubber seals, o-ring & AISI 316 stainless steel bushings and washers

For the Selection Guide, Load Ratings and Speed Limits, see the Klean-Gard & Dura-Klean Ball Bearings Engineering section on pages 456 - 458.

Note: Dimensions subject to change. Certified dimensions of ordered material furnished on request.

KLFSS200

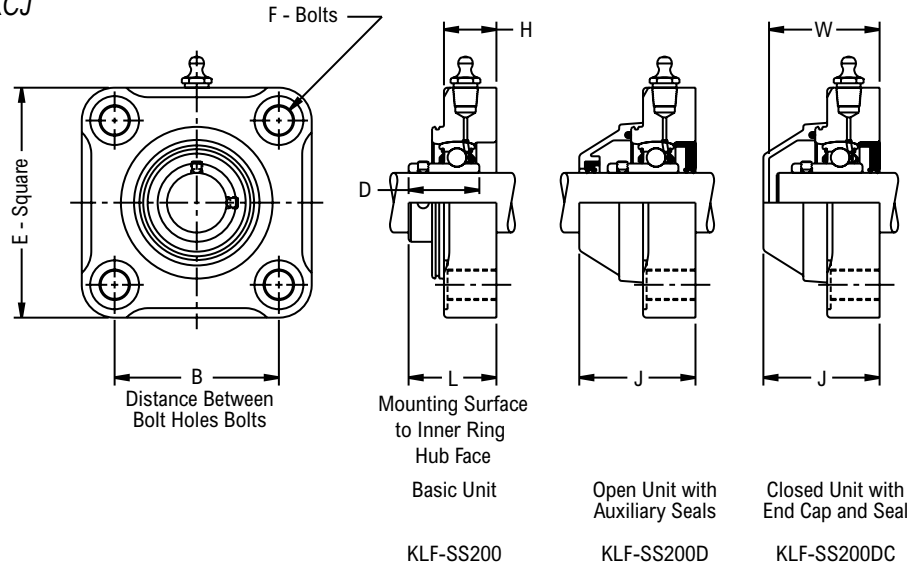
Interchange: F4BSCEZ, SUCF200-PBT, KCJ



Photo Shows a 4-Bolt Ball Bearing Flanged Unit with Stainless Steel Insert and Polypropylene Housing

Product Features

- Reinforced Polypropylene housing
- Stainless steel bearing insert
- Stainless steel bushing & washers
- Spring locking setscrew mount
- Alignable & relubricatable
- Prelubricated with food grade grease
- See Features and Benefits for additional info on page 454.



Bearing Dimensions

Size Code	Shaft Diameter	Polypropylene		B Distance Between Bolt Holes	L Mounting Surface to Inner Ring Hub Face	D	E	F Bolts	H	J	W	Approx. Weight
		Part Number										
205	1	KLFSS216		2.76	1 ¹⁵ / ₃₂	1 ³ / ₁₆	3 ⁵⁵ / ₆₄	7/16	7/8	1 ⁶¹ / ₆₄	1 ⁷ / ₈	0.90
	25.00	KLFSS2M25		70.00	37.30	30.17	98.00	11.00	22.50	49.50	47.50	0.41
206	1 ³ / ₁₆	KLFSS219		3.27	1 ³ / ₄	1 ¹¹ / ₃₂	4 ²¹ / ₆₄	7/16	1 ¹ / ₆₄	2 ¹¹ / ₆₄	2 ³ / ₃₂	1.40
	1 ¹ / ₄	KLFSS2E20										
	30.00	KLFSS2M30		83.00	44.20	34.13	110.00	11.00	26.00	55.00	53.00	0.63
207	1 ¹ / ₄	KLFSS220		3.62	1 ⁷ / ₈	1 ⁹ / ₁₆	4 ²³ / ₃₂	7/16	1 ¹ / ₆₄	2 ²¹ / ₆₄	2 ¹ / ₄	1.90
	1 ³ / ₈	KLFSS222										
	1 ⁷ / ₁₆	KLFSS223										
	35.00	KLFSS2M35		92.00	47.70	39.67	120.00	11.00	26.00	59.00	57.00	0.86
208	1 ¹ / ₂	KLFSS224		4.02	2 ¹ / ₁₆	1 ¹¹ / ₁₆	5 ⁵ / ₃₂	7/16	1 ³ / ₁₆	2 ³⁷ / ₆₄	2 ¹⁵ / ₃₂	2.50
	40.00	KLFSS2M40		102.00	52.40	42.87	131.00	11.00	30.00	65.50	62.50	1.13

Additional Notes

- Please call 1-866-REXNORD for availability
- Lubrication fitting tap size, Rp 1/8" parallel thread per ISO 7/1 latest revision
- Note: 1/8" PT external thread will not fit
- Polypropylene housings furnished with nitrile rubber seals, o-ring & AISI 316 stainless steel bushings and washers

For the Selection Guide, Load Ratings and Speed Limits, see the Klean-Gard & Dura-Klean Ball Bearings Engineering section on pages 456 - 458.
 Note: Dimensions subject to change. Certified dimensions of ordered material furnished on request.

KLFBS200

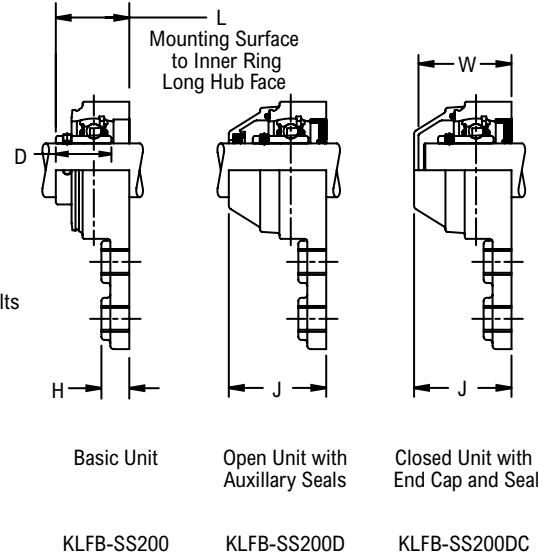
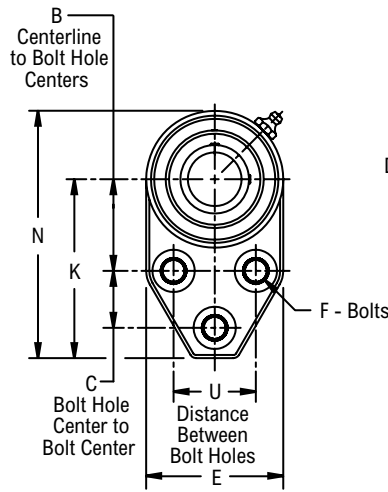
Interchange: FBSCEZ, SUCFB200-PBT



Photo Shows a 3-Bolt Ball Bearing Flanged Bracket Unit with Stainless Steel Insert and Polypropylene Housing

Product Features

- Reinforced Polypropylene housing
- Stainless steel bearing insert
- Stainless steel bushing & washers
- Spring locking setscrew mount
- Alignable & relubricatable
- Prelubricated with food grade grease
- See Features and Benefits for additional info on page 454.



Bearing Dimensions

Size Code	Shaft Diameter	Polypropylene	B Centerline to Bolt Hole Center	C Bolt Hole Center to Bolt Center	L Mounting Surface to Inner Ring	U Distance Between Bolt Holes	D	E	F Bolts	H	J	K	N	W	Approx. Weight
		Part Number													
205	1	KLFBS216	1 13/16	1 1/8	1 17/32	1 5/8	1 3/16	2 23/32	7/16	9/16	2 1/64	3 17/32	4 57/64	1 15/16	0.60
	25.00	KLFBS2M25	46.00	28.58	38.90	41.28	30.17	69.00	11.00	14.00	51.20	89.80	124.00	49.20	0.27
206	1 3/16	KLFBS219	2 1/16	1 1/4	1 3/4	1 7/8	1 11/32	3 13/64	7/16	9/16	2 11/64	3 55/64	5 15/32	2 3/32	1.10
	1 1/4	KLFBS2E20													
	30.00	KLFBS2M30	52.40	31.70	44.20	47.60	34.13	81.00	11.00	14.00	55.20	97.90	139.00	53.20	0.50
207	1 1/4	KLFBS220	2 3/8	1 1/4	1 7/8	2	1 9/16	3 11/16	7/16	9/16	2 21/64	4 15/64	6 5/64	2 1/4	1.60
	1 3/8	KLFBS222													
	1 7/16	KLFBS223													
	35.00	KLFBS2M35	60.30	31.70	47.70	50.80	39.67	94.00	11.00	14.00	59.10	107.60	154.00	57.20	0.72

Additional Notes

- Please call 1-866-REXNORD for availability
- Lubrication fitting tap size, Rp 1/8" parallel thread per ISO 7/1 latest revision
- Note: 1/8" PT external thread will not fit
- Polypropylene housings furnished with nitrile rubber seals, o-ring & AISI 316 stainless steel bushings and washers

For the Selection Guide, Load Ratings and Speed Limits, see the Klean-Gard & Dura-Klean Ball Bearings Engineering section on pages 456 - 458.
 Note: Dimensions subject to change. Certified dimensions of ordered material furnished on request.

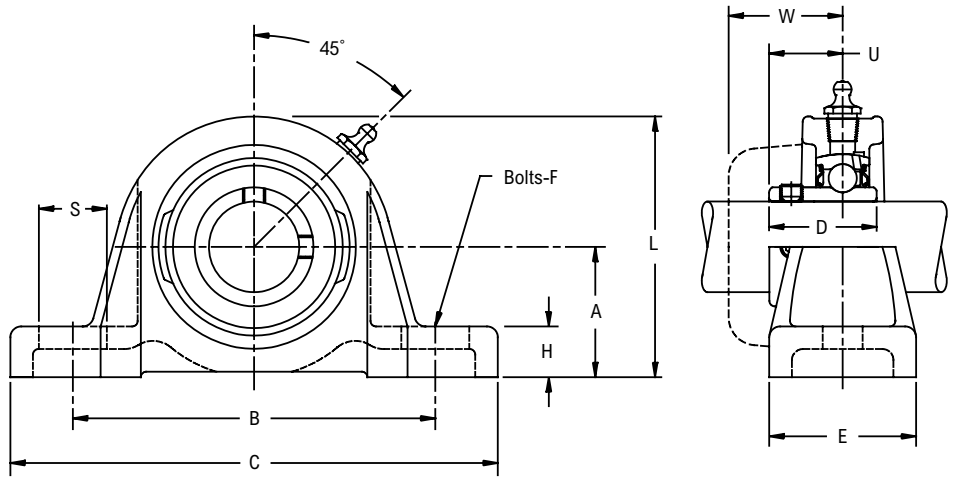
WP3S200



Photo Shows a 2-Bolt Ball Bearing Pillow Block Unit with Nylon Coated Housing

Product Features

- Corrosion resistant nylon coating
- Cast iron housing
- Inner & outer rings black oxide coated
- Spring locking setscrew mount
- Alignable & relubricatable
- Prelubricated with food grade grease
- See Features and Benefits for additional info on page 454.



Bearing Dimensions

Size Code	Shaft Diameter	Part Number	A Base to Centerline Height	B Distance Between Bolt Holes	C	D	E	F Bolts	H	L	S	U	W	Approx. Weight
204	³ / ₄	WP3S212E	1 ⁵ / ₁₆	3 ⁷ / ₈	5 ¹ / ₈	1 ¹ / ₈	1 ¹ / ₂	³ / ₈	¹ / ₂	2 ¹⁹ / ₃₂	¹¹ / ₁₆	³ / ₄	1 ¹⁹ / ₆₄	1.60
	20.00	WP3S2M20E	33.34	98.40	130.20	28.58	38.10	10.00	12.70	65.90	17.50	19.00	32.90	0.72
205	⁷ / ₈	WP3S214E	1 ⁷ / ₁₆	4	5 ³ / ₈	1 ¹¹ / ₆₄	1 ⁵ / ₈	³ / ₈	⁹ / ₁₆	2 ⁷ / ₈	¹¹ / ₁₆	¹³ / ₁₆	1 ⁹ / ₃₂	1.90
	¹⁵ / ₁₆	WP3S215E												
	1	WP3S216E												
	25.00	WP3S2M25E	36.51	101.60	136.50	30.17	41.30	10.00	14.30	73.00	17.50	20.60	32.50	0.86
206	1 ¹ / ₈	WP3S218E	1 ¹¹ / ₁₆	4 ⁵ / ₈	6 ⁵ / ₁₆	1 ¹¹ / ₃₂	1 ³ / ₄	¹ / ₂	¹¹ / ₁₆	3 ⁵ / ₁₆	¹⁵ / ₁₆	⁶ / ₆₄	1 ²⁹ / ₆₄	2.80
	1 ³ / ₁₆	WP3S219E												
	1 ¹ / ₄	WP3S2E20E												
	30.00	WP3S2M30E	42.86	117.50	160.30	34.13	44.40	12.00	17.50	84.10	23.80	24.20	36.90	1.26
207	1 ¹ / ₄	WP3S220E	1 ⁷ / ₈	4 ¹⁵ / ₁₆	6 ³ / ₈	1 ⁹ / ₁₆	1 ⁷ / ₈	¹ / ₂	¹³ / ₁₆	3 ¹¹ / ₁₆	¹³ / ₁₆	1 ⁷ / ₆₄	1 ³⁵ / ₆₄	3.50
	1 ³ / ₈	WP3S222E												
	1 ⁷ / ₁₆	WP3S223E												
	35.00	WP3S2M35E	47.62	125.40	161.90	39.67	47.60	12.00	20.60	93.70	20.60	28.20	39.30	1.58
208	1 ¹ / ₂	WP3S224E	2	5 ³ / ₈	7 ⁷ / ₁₆	1 ¹¹ / ₁₆	1 ⁷ / ₈	¹ / ₂	¹³ / ₁₆	4	¹⁵ / ₁₆	1 ¹³ / ₆₄	1 ⁴¹ / ₆₄	4.40
	40.00	WP3S2M40E	50.80	136.50	179.40	42.87	47.60	12.00	20.60	101.60	23.80	30.60	41.70	1.98
209	1 ⁵ / ₈	WP3S226E	2 ¹ / ₈	5 ⁵ / ₈	7 ¹ / ₄	1 ⁴⁹ / ₆₄	2	¹ / ₂	¹³ / ₁₆	4 ⁵ / ₁₆	⁷ / ₈	1 ¹⁵ / ₆₄	1 ²¹ / ₃₂	5.50
	1 ¹¹ / ₁₆	WP3S227E												
	1 ³ / ₄	WP3S228E												
210	1 ¹⁵ / ₁₆	WP3S231E	2 ¹ / ₄	6 ³ / ₁₆	7 ⁷ / ₈	1 ⁵¹ / ₆₄	2 ¹ / ₈	⁵ / ₈	⁷ / ₈	4 ¹ / ₂	¹⁵ / ₁₆	1 ¹⁷ / ₆₄	1 ²⁵ / ₃₂	5.80

Additional Notes

- Please call 1-866-REXNORD for availability
- Lubrication fitting tap size, 1/8" PT
- Base to centerline tolerance, +.000 in/-0.010 in (+0.00 mm/-0.25 mm)
- For the Selection Guide, Load Ratings and Speed Limits, see the Klean-Gard & Dura-Klean Ball Bearings Engineering section on pages 456 - 458.

Note: Dimensions subject to change. Certified dimensions of ordered material furnished on request.

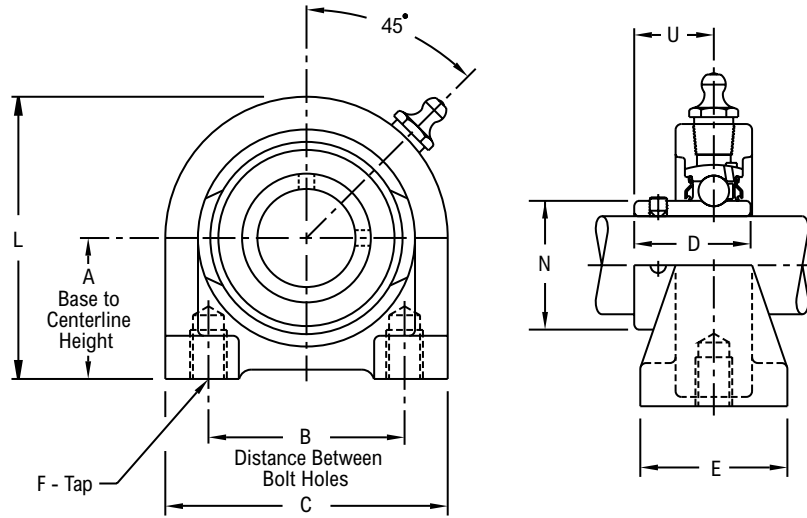
WPT3S200



Photo Shows a 2-Bolt Ball Bearing Tapped Base Pillow Block with Nylon Coated Housing

Product Features

- Corrosion resistant nylon coating
- Cast iron tapped base housing
- Inner & outer rings black oxide coated
- Spring locking setscrew mount
- Alignable & relubricatable
- Prelubricated with food grade grease
- See Features and Benefits for additional info on page 454.



Bearing Dimensions

Size Code	Shaft Diameter	Part Number	A Base to Centerline Height	B Distance Between Bolt Holes	C	D	E	F Depth	F Tap	L	N	U	Approx. Weight
204	³ / ₄	WPT3S212E	1 ⁵ / ₁₆	2	2 ⁷ / ₈	1 ¹ / ₈	1 ¹ / ₂	¹ / ₂	3/8-16	2 ¹⁹ / ₃₂	1 ¹ / ₈	³ / ₄	1.30
	20.00	WPT3S2M20E	33.34	50.80	73.00	28.58	38.10	12.70	3/8-16	65.90	28.600	19.00	0.59
205	⁷ / ₈	WPT3S214E	1 ⁷ / ₁₆	2	2 ⁷ / ₈	1 ¹¹ / ₆₄	1 ¹ / ₂	¹ / ₂	3/8-16	2 ⁷ / ₈	1 ⁵ / ₁₆	⁵ / ₆₄	1.50
	¹⁵ / ₁₆	WPT3S215E											
	1	WPT3S216E											
	25.00	WPT3S2M25E	36.51	50.80	73.00	29.77	38.10	12.70	3/8-16	73.00	33.300	20.20	0.68
206	1 ¹ / ₈	WPT3S218E	1 ¹¹ / ₁₆	3	4	1 ¹¹ / ₃₂	1 ¹ / ₂	⁵ / ₈	7/16-14	3 ⁵ / ₁₆	1 ¹⁹ / ₃₂	⁶ / ₆₄	2.50
	1 ³ / ₁₆	WPT3S219E											
	1 ¹ / ₄	WPT3S2E20E											
	30.00	WPT3S2M30E	42.86	76.20	101.60	34.13	38.10	15.90	7/16-14	84.10	40.500	24.20	1.13
207	1 ¹ / ₄	WPT3S220E	1 ⁷ / ₈	3 ¹ / ₄	4 ¹³ / ₃₂	1 ⁹ / ₁₆	1 ⁷ / ₈	³ / ₄	1/2-13	3 ¹¹ / ₁₆	1 ²⁷ / ₃₂	1 ⁷ / ₆₄	3.60
	1 ³ / ₈	WPT3S222E											
	1 ⁷ / ₁₆	WPT3S223E											
	35.00	WPT3S2M35E	47.62	82.55	111.90	39.67	47.60	19.00	1/2-13	93.70	46.900	28.20	1.62
210	1 ¹⁵ / ₁₆	WPT3S231E	2 ¹ / ₄	4	5 ⁷ / ₁₆	1 ¹³ / ₁₆	2	⁷ / ₈	5/8-11	4 ¹ / ₂	2 ¹⁵ / ₃₂	1 ¹⁷ / ₆₄	5.70

Additional Notes

- Please call 1-866-REXNORD for availability
- Lubrication fitting tap size, 1/8" PT
- Base to centerline tolerance, +.000 in/- .010 in (**+0.00 mm/-0.25 mm**)
- For the Selection Guide, Load Ratings and Speed Limits, see the Klean-Gard & Dura-Klean Ball Bearings Engineering section on pages 456 - 458.

Note: Dimensions subject to change. Certified dimensions of ordered material furnished on request.

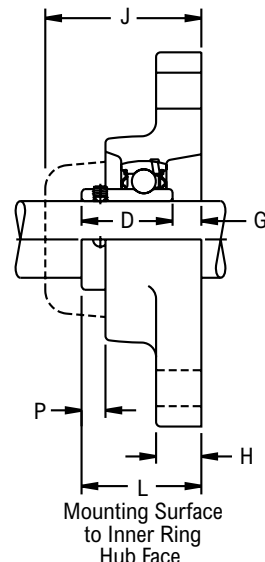
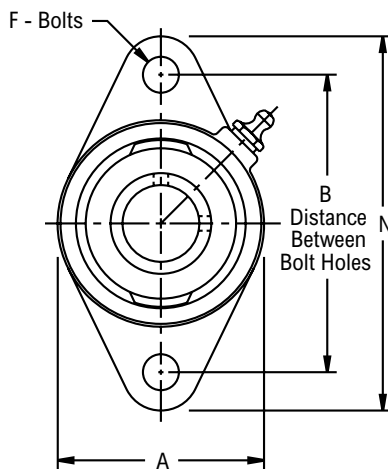
WFX3S200



Photo Shows a 2-Bolt Ball Bearing Flanged Unit with Nylon Coated Housing

Product Features

- Corrosion resistant nylon coating
- Cast iron housing
- Inner & outer rings black oxide coated
- Spring locking setscrew mount
- Alignable & relubricatable
- Prelubricated with food grade grease
- See Features and Benefits for additional info on page 454.



Bearing Dimensions

Size Code	Shaft Diameter	Part Number	B Distance Between Bolt Holes	L Mounting Surface to Inner Ring Hub Face	A	D	F Bolts	G	H	J	N	P	Approx. Weight	
204	$\frac{3}{4}$	WFX3S212E	$3 \frac{17}{32}$	$1 \frac{31}{64}$	$2 \frac{7}{16}$	$1 \frac{1}{8}$	$\frac{3}{8}$	$\frac{23}{64}$	$\frac{9}{16}$	$2 \frac{1}{64}$	$4 \frac{13}{32}$	$\frac{9}{32}$	1.10	
	20.00	WFX3S2M20E	89.69	37.70	61.90	28.58	10.00	9.10	14.30	51.20	111.90	7.10	0.50	
205	$\frac{7}{8}$	WFX3S214E	$3 \frac{57}{64}$	$1 \frac{35}{64}$	$2 \frac{11}{16}$	$1 \frac{11}{64}$	$\frac{7}{16}$	$\frac{3}{8}$	$\frac{19}{32}$	2	$4 \frac{29}{32}$	$\frac{19}{64}$	1.50	
	$\frac{15}{16}$	WFX3S215E												
	1	WFX3S216E	25.00	WFX3S2M25E	98.82	39.30	68.30	29.77	10.00	9.50	15.10	50.80	124.60	7.50
206	$1 \frac{1}{8}$	WFX3S218E	$4 \frac{19}{32}$	$1 \frac{47}{64}$	$3 \frac{3}{16}$	$1 \frac{11}{32}$	$\frac{7}{16}$	$\frac{25}{64}$	$\frac{19}{32}$	$2 \frac{15}{64}$	$5 \frac{19}{32}$	$\frac{27}{64}$	2.20	
	$1 \frac{3}{16}$	WFX3S219E												
	$1 \frac{1}{4}$	WFX3S2E20E	30.00	WFX3S2M30E	116.68	44.00	81.00	34.13	10.00	9.90	15.10	56.70	142.10	10.70
207	$1 \frac{1}{4}$	WFX3S220E	$5 \frac{1}{8}$	$1 \frac{59}{64}$	$3 \frac{5}{8}$	$1 \frac{9}{16}$	$\frac{1}{2}$	$\frac{23}{64}$	$\frac{5}{8}$	$2 \frac{23}{64}$	$6 \frac{1}{8}$	$\frac{33}{64}$	2.70	
	$1 \frac{3}{8}$	WFX3S222E												
	$1 \frac{7}{16}$	WFX3S223E	35.00	WFX3S2M35E	130.18	48.80	92.10	39.69	12.00	9.10	15.90	59.90	155.60	13.10
208	$1 \frac{1}{2}$	WFX3S224E	$5 \frac{21}{32}$	$2 \frac{5}{64}$	4	$1 \frac{21}{32}$	$\frac{1}{2}$	$\frac{27}{64}$	$\frac{5}{8}$	$2 \frac{35}{64}$	$6 \frac{25}{32}$	$\frac{1}{2}$	3.80	
	40.00	WFX3S2M40E	143.67	52.80	101.60	42.06	12.00	10.70	15.90	65.10	172.20	12.70	1.70	
209	$1 \frac{5}{8}$	WFX3S226E	$5 \frac{27}{32}$	$2 \frac{9}{64}$	$4 \frac{1}{4}$	$1 \frac{49}{64}$	$\frac{1}{2}$	$\frac{3}{8}$	$\frac{5}{8}$	$2 \frac{9}{16}$	$7 \frac{3}{32}$	$\frac{35}{64}$	4.40	
	$1 \frac{11}{16}$	WFX3S227E												
	$1 \frac{3}{4}$	WFX3S228E	119.10	48.80	101.60	42.06	12.00	10.70	15.90	65.10	172.20	12.70	1.70	
210	$1 \frac{15}{16}$	WFX3S231E	$6 \frac{3}{16}$	$2 \frac{25}{64}$	$4 \frac{9}{16}$	$1 \frac{13}{16}$	$\frac{9}{16}$	$\frac{37}{64}$	$\frac{3}{4}$	$2 \frac{57}{64}$	$7 \frac{7}{16}$	$\frac{35}{64}$	5.60	

Additional Notes

- Please call 1-866-REXNORD for availability
- Lubrication fitting tap size, 1/8" PT
- For the Selection Guide, Load Ratings and Speed Limits, see the Klean-Gard & Dura-Klean Ball Bearings Engineering section on pages 456 - 458.
- Note: Dimensions subject to change. Certified dimensions of ordered material furnished on request.

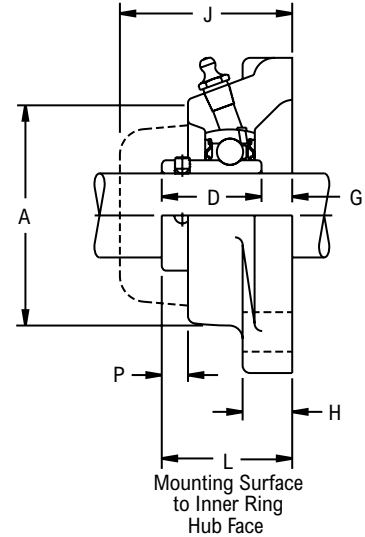
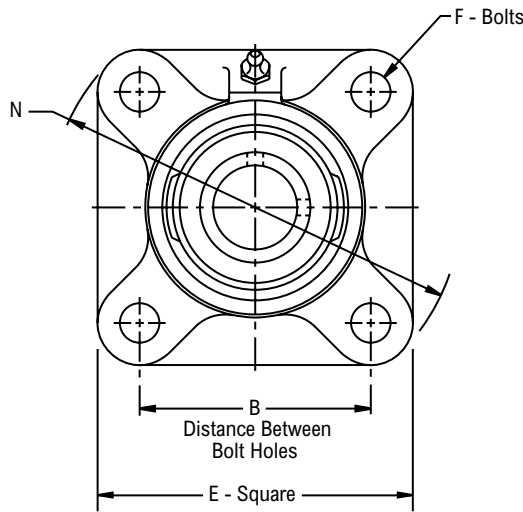
WF3S200



Photo Shows a 4-Bolt Ball Bearing Flanged Unit with Nylon Coated Housing

Product Features

- Corrosion resistant nylon coating
- Cast iron housing
- Inner & outer rings black oxide coated
- Spring locking setscrew mount
- Alignable & relubricatable
- Prelubricated with food grade grease
- See Features and Benefits for additional info on page 454.



Bearing Dimensions

Size Code	Shaft Diameter	Part Number	B Distance Between Bolt Holes	L Mounting Surface to Inner Ring Hub Face	A	D	E	F Bolts	G	H	J	N	P	Approx. Weight
204	³ / ₄	WF3S212E	2 ¹ / ₂	1 ³¹ / ₆₄	2 ⁷ / ₁₆	1 ¹ / ₈	3 ³ / ₈	³ / ₈	²³ / ₆₄	⁹ / ₁₆	2 ¹ / ₆₄	4 ¹³ / ₃₂	⁹ / ₃₂	1.60
	20.00	WF3S2M20E	63.50	37.70	61.90	28.58	85.70	10.00	9.10	14.30	51.20	111.90	7.10	0.72
205	⁷ / ₈	WF3S214E	2 ³ / ₄	1 ³⁵ / ₆₄	2 ¹¹ / ₁₆	1 ¹¹ / ₆₄	3 ³ / ₄	⁷ / ₁₆	³ / ₈	¹⁹ / ₃₂	2	4 ²⁹ / ₃₂	¹⁹ / ₆₄	1.90
	¹⁵ / ₁₆	WF3S215E												
	1	WF3S216E												
	25.00	WF3S2M25E												
206	1 ¹ / ₈	WF3S218E	3 ¹ / ₄	1 ⁴⁷ / ₆₄	3 ³ / ₁₆	1 ¹¹ / ₃₂	4 ¹ / ₄	⁷ / ₁₆	²⁵ / ₆₄	¹⁹ / ₃₂	2 ¹⁵ / ₆₄	5 ¹⁹ / ₃₂	²⁷ / ₆₄	2.60
	1 ³ / ₁₆	WF3S219E												
	1 ¹ / ₄	WF3S2E20E												
	30.00	WF3S2M30E												
207	1 ¹ / ₄	WF3S220E	3 ⁵ / ₈	1 ⁵⁹ / ₆₄	3 ⁵ / ₈	1 ⁹ / ₁₆	4 ⁵ / ₈	¹ / ₂	²³ / ₆₄	⁵ / ₈	2 ²³ / ₆₄	6 ¹ / ₈	³⁷ / ₆₄	3.40
	1 ³ / ₈	WF3S222E												
	1 ⁷ / ₁₆	WF3S223E												
	35.00	WF3S2M35E												
208	1 ¹ / ₂	WF3S224E	4	2 ⁵ / ₆₄	4	1 ²¹ / ₃₂	5 ¹ / ₈	¹ / ₂	²⁷ / ₆₄	⁵ / ₈	2 ³⁵ / ₆₄	6 ²⁵ / ₃₂	¹ / ₂	4.70
	40.00	WF3S2M40E	101.60	52.80	101.60	42.06	130.20	12.00	10.70	15.90	64.70	172.20	12.70	2.12
209	1 ⁵ / ₈	WF3S226E	4 ¹ / ₈	2 ⁹ / ₆₄	4 ¹ / ₄	1 ⁴⁹ / ₆₄	5 ³ / ₈	¹ / ₂	³ / ₈	⁵ / ₈	2 ⁹ / ₁₆	7 ³ / ₃₂	³⁵ / ₆₄	5.40
	1 ¹¹ / ₁₆	WF3S227E												
	1 ³ / ₄	WF3S228E												
210	1 ¹⁵ / ₁₆	WF3S231E	4 ³ / ₈	2 ¹⁹ / ₆₄	4 ¹ / ₂	1 ¹³ / ₁₆	5 ⁵ / ₈	¹ / ₂	¹ / ₂	³ / ₄	2 ¹³ / ₁₆	7 ⁷ / ₁₆	⁹ / ₁₆	6.20

Additional Notes

- Please call 1-866-REXNORD for availability
- Lubrication fitting tap size, 1/8" PT
- For the Selection Guide, Load Ratings and Speed Limits, see the Klean-Gard & Dura-Klean Ball Bearings Engineering section on pages 456 - 458.
- Note: Dimensions subject to change. Certified dimensions of ordered material furnished on request.

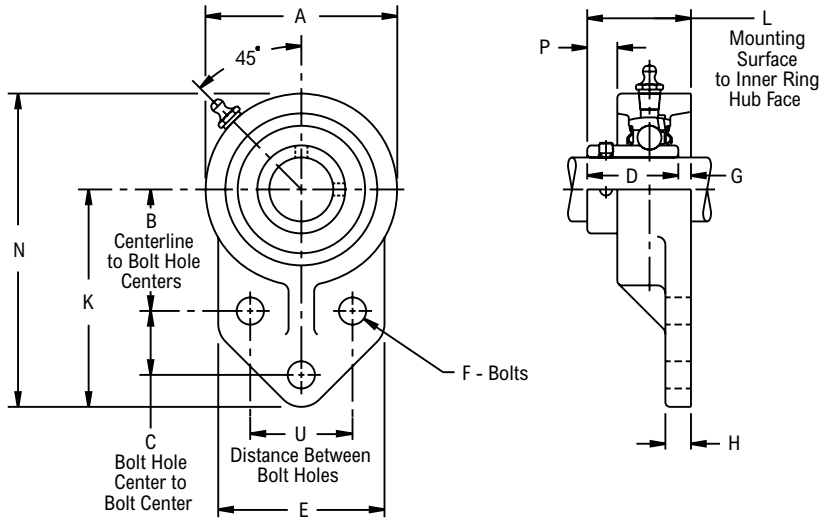
WFB3S200



Photo Shows a 3-Bolt Ball Bearing Flanged Bracket Unit with Nylon Coated Housing

Product Features

- Corrosion resistant nylon coating
- Cast iron housing
- Inner & outer rings black oxide coated
- Spring locking setscrew mount
- Alignable & relubricatable
- Prelubricated with food grade grease
- See Features and Benefits for additional info on page 454.



Bearing Dimensions

Size Code	Shaft Diameter	Part Number	B Centerline to Bolt Hole Centers	C Bolt Hole Center to Bolt Center	L Mounting Surface to Inner Ring	U Distance Between Bolt Holes	A	D	E	F Bolts	G	H	K	N	P	Approx. Weight
204	³ / ₄	WFB3S212E	1 ¹¹ / ₁₆	⁷ / ₈	1 ¹¹ / ₃₂	1 ¹ / ₂	2 ¹ / ₂	1 ¹ / ₈	2 ³ / ₈	³ / ₈	⁷ / ₃₂	⁵ / ₁₆	3	4 ¹ / ₄	¹¹ / ₃₂	1.20
	20.00	WFB3S2M20E	42.90	22.20	34.10	38.10	63.50	28.58	60.30	10.00	5.50	7.90	76.20	108.00	8.70	0.54
205	⁷ / ₈	WFB3S214E	1 ¹³ / ₁₆	1 ¹ / ₈	1 ²⁹ / ₆₄	1 ⁵ / ₈	2 ³ / ₄	1 ¹¹ / ₆₄	2 ¹ / ₂	³ / ₈	⁹ / ₃₂	³ / ₈	3 ³ / ₈	4 ³ / ₄	¹⁹ / ₆₄	1.70
	¹⁵ / ₁₆	WFB3S215E														
	1	WFB3S216E	25.00	46.00	28.60	38.90	41.30	69.80	29.77	63.50	10.00	7.10	9.50	85.70	120.60	7.50
206	1 ¹ / ₈	WFB3S218E	2 ¹ / ₁₆	1 ¹ / ₄	1 ⁵ / ₈	1 ⁷ / ₈	3 ¹ / ₄	1 ¹¹ / ₃₂	2 ³ / ₄	³ / ₈	⁹ / ₃₂	³ / ₈	3 ³ / ₄	5 ³ / ₈	³ / ₈	2.20
	1 ³ / ₁₆	WFB3S219E														
	1 ¹ / ₄	WFB3S2E20E	30.00	52.30	31.80	43.70	47.60	82.60	34.13	69.80	10.00	7.10	9.50	95.20	136.50	9.50
207	1 ¹ / ₄	WFB3S220E	2 ³ / ₈	1 ¹ / ₄	1 ⁵⁹ / ₆₄	2	3 ³ / ₄	1 ⁹ / ₁₆	3 ¹ / ₄	¹ / ₂	²³ / ₆₄	¹ / ₂	4 ¹ / ₄	6 ¹ / ₈	³¹ / ₆₄	3.20
	1 ³ / ₈	WFB3S222E														
	1 ⁷ / ₁₆	WFB3S223E	35.00	60.30	31.80	48.80	50.80	95.20	39.67	82.60	12.00	9.10	12.70	108.00	155.60	12.30

Additional Notes

- Please call 1-866-REXNORD for availability
- Lubrication fitting tap size, 1/4"-28 UNF
- For the Selection Guide, Load Ratings and Speed Limits, see the Klean-Gard & Dura-Klean Ball Bearings Engineering section on pages 456 - 458.
- Note: Dimensions subject to change. Certified dimensions of ordered material furnished on request.

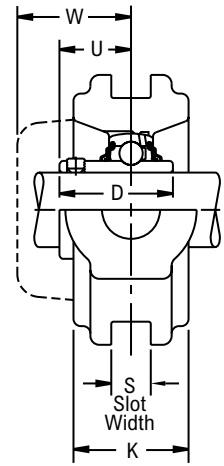
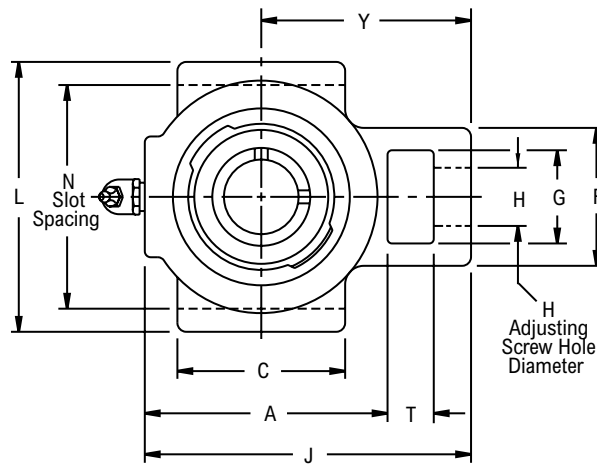
WTH3S200



Photo Shows a Ball Bearing Take-Up Unit with Nylon Coated Housing

Product Features

- Corrosion resistant nylon coating
- Cast iron housing
- Inner & outer rings black oxide coated
- Spring locking setscrew mount
- Alignable & relubricatable
- Pretubricated with food grade grease
- See Features and Benefits for additional info on page 454.



Bearing Dimensions

Size Code	Shaft Diameter	Part Number	H Adjusting Screw Hole Diameter	N Slot Spacing	S Slot Width	A	C	D	F	G	J	K	L	T	U	W	Y	Approx. Weight
204	3/4	WTH3S212E	3/4	3.000	0.531	2 27/32	2 1/4	1 1/8	1 7/8	1 1/4	3 31/32	1 1/16	3 5/8	5/8	3/4	1 5/16	2 21/32	2.40
	20.00	WTH3S2M20E	19.00	76.200	13.490	72.20	57.20	28.58	47.60	31.80	100.80	27.00	92.10	15.90	19.00	33.30	67.50	1.10
205	7/8	WTH3S214E	3/4	3.000	0.531	2 29/32	2 1/4	1 11/64	1 27/32	1 1/4	4 1/32	1 3/32	3 5/8	5/8	51/64	1 5/16	2 21/32	2.70
	15/16	WTH3S215E																
	1	WTH3S216E																
	25.00	WTH3S2M25E	19.00	76.200	13.490	73.80	57.20	29.77	46.80	31.80	102.40	27.80	92.10	15.90	20.20	33.30	67.50	1.20
206	1 1/8	WTH3S218E	7/8	3.500	0.531	3 11/32	2 1/2	1 11/32	2 3/16	1 7/16	4 15/32	1 3/32	4 1/8	5/8	61/64	1 29/64	2 27/32	3.20
	1 3/16	WTH3S219E																
	1 1/4	WTH3S2E20E																
	30.00	WTH3S2M30E	22.20	88.900	13.490	84.90	63.50	34.13	55.60	36.50	113.50	27.80	104.80	15.90	24.20	36.90	72.20	1.44
207	1 1/4	WTH3S220E	7/8	3.500	0.531	3 11/16	2 3/4	1 9/16	2 5/16	1 7/16	4 13/16	1 3/16	4 1/8	5/8	1 7/64	1 35/64	2 31/32	4.00
	1 3/8	WTH3S222E																
	1 7/16	WTH3S223E																
	35.00	WTH3S2M35E	22.20	88.900	13.490	93.70	69.80	39.67	58.70	36.50	122.20	30.20	104.80	15.90	28.20	39.30	75.40	1.80
208	1 1/2	WTH3S224E	1 1/8	3.969	0.688	4 3/16	3 1/4	1 21/32	2 27/32	1 15/16	5 9/16	1 5/16	4 3/4	3/4	1 11/64	1 41/64	3 15/32	5.30
	40.00	WTH3S2M40E	28.60	100.810	17.480	106.40	82.60	42.06	72.20	49.20	141.30	33.30	120.60	19.00	29.80	41.70	88.60	2.38
209	1 5/8	WTH3S226E	1 1/8	3.969	0.688	4 3/16	3 1/4	1 49/64	2 7/8	1 15/16	5 9/16	1 3/8	4 3/4	3/4	1 15/64	1 21/32	3 15/32	5.30
	1 11/16	WTH3S227E																
	1 3/4	WTH3S228E																
	1 15/16	WTH3S231E	1 1/8	3.969	0.688	4 9/16	3 3/8	1 13/16	2 7/8	1 15/16	5 15/16	1 43/64	4 3/4	3/4	1 17/64	1 25/32	3 19/32	6.60

Additional Notes

- Please call 1-866-REXNORD for availability
- Lubrication fitting tap size, 1/8" PT
- For the Selection Guide, Load Ratings and Speed Limits, see the Klean-Gard & Dura-Klean Ball Bearings Engineering section on pages 456 - 458.
- Note: Dimensions subject to change. Certified dimensions of ordered material furnished on request.



Rear Auxiliary Seal



Open Cap with Seal & O-ring



Closed Cap with O-ring

Klean-Gard Accessory Kit Part Numbers

Shaft Size	Basic Unit Number	KL Polypropylene Hsg (White) DC - Closed Cap with O-ring	KL Polypropylene Hsg D - Open Cap with Seal & O-ring	KL Polypropylene Rear Auxiliary Seal
$\frac{3}{4}$	212	K2126	KL2126D	KL212E
<i>20.00</i>	<i>2M20</i>	<i>K2126</i>	<i>KL2M206D</i>	<i>KL2M20E</i>
1	216	K2166	KL2166D	KL216E
<i>25.00</i>	<i>2M25</i>	<i>K2166</i>	<i>KLM256D</i>	<i>KL2M25E</i>
$1 \frac{3}{16}$	219	K2196	KL2196D	KL219E
$1 \frac{1}{4}$	2E20	K2196	KL2E206D	KL2E20E
<i>30.00</i>	<i>2M30</i>	<i>K2196</i>	<i>KL2M306D</i>	<i>KL2M30E</i>
$1 \frac{1}{4}$	220	K2236	KL2206D	KL220E
$1 \frac{3}{8}$	222	K2236	KL2226D	KL222E
$1 \frac{7}{16}$	223	K2236	KL2236D	KL223E
<i>35.00</i>	<i>2M35</i>	<i>K2236</i>	<i>KL2M356D</i>	<i>KL2M35E</i>
$1 \frac{1}{2}$	224	K2256	KL2246D	KL224E
<i>40.00</i>	<i>2M40</i>	<i>K2256</i>	<i>KL2M406D</i>	<i>KL2M40E</i>

Cylindrical Roller Bearings: Link-Belt



Contents

	Page
Features and Benefits	472
Nomenclature	473
Engineering	474
Dimensions	
Single Row	491
Double Row	499

Industries Served

Heavy-Duty Truck
Fluid Handling
Off-Highway Vehicles
Military
Oil/Natural Gas
Steel



Series M1000, 1200, 1300, 1900, 5200, 5300, 6200, 7300 Cylindrical Roller Bearings

Metric series cylindrical roller bearings are manufactured to ABMA boundary dimensions. These bearings require minimum space and provide maximum rated capacity. Various configurations including separable inner or outer ring combinations offer ample application flexibility.



High Quality Rings

Rings of high quality bearing steel for strength, toughness and durability.

Microfinished Raceways Assure Smooth Operations

Optimized Raceway Contact Area

Exclusive honed crown on roller profile for optimized raceway contact area and high capacity.

Positive Roller Spacing

- Structural design segmented retainer provides high strength, positive roller spacing and guidance.
- One-piece formed Steel Retainer provides positive roller spacing and controlled roller guidance.

Polymeric Retainer

Polymeric retainer of glass fiber reinforced nylon 6/6 provides full roller guidance, superior lubrication and reduced noise.

Segmented Retainers

Rigid structural design segmented Steel Retainer provides high strength, positive roller spacing and guidance.

All contact surfaces are contoured to minimize the wiping action between retainer segments and rollers, assuring full roller lubrication. Precision spacer segments contact the rollers above and below pitch diameter resulting in low friction loss and positive roller control.



Polymeric Retainers

Made of glass fiber reinforced nylon 6/6, molded polymeric retainers provide close control of roller "drop," low noise, full roller guidance and superior lubrication, at a competitive price.

Extensive testing has established compatibility with a broad range of standard lubricants and satisfactory operation at sustained temperatures to 275°F.



Formed Steel Retainers

One-piece deep coined formed Steel Retainer combines strength with positive roller spacing and roller guidance.

The retainer guides the rollers below the pitch line and provides control of roller drop. Line contact of rollers on guidance surfaces minimizes wiping action and promotes hydrodynamic lubrication.



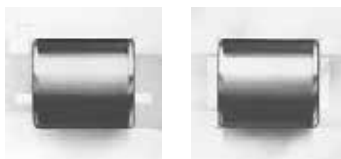
Optional Series and Configurations

Series M cylindrical roller bearings are available in seven series with segmented retainers, five series with formed Steel Retainers, several series with polymeric retainers, and five series of the full roller complement type. Various configurations, including separable inner or outer ring combinations are offered.



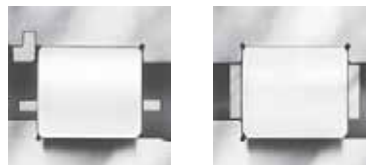
Rollers

Exclusively crowned honed rollers provide optimized contact at the raceway. This assures efficient bearing performance under load, provides controlled stress distribution under all loads within the design capacity and compensates for shaft deflection.



Rings

Rings are manufactured from high quality bearing steel to enhance fatigue resistance, strength, toughness and hardenability.



Bearings and ring and roller assemblies for omitted-ring applications are ABMA standard boundary plan for bore, outside diameter, and width... standard tolerances are RBEC-1. Precision tolerances to RBEC-5 are available.

Nomenclature

Symbol	Description	M	A	1	2	05	GEA	X	C0	
M	Metric series designation									
A	Plain cylindrical inner ring									
R	Single rib inner ring									
SN	Short, single rib w/inner ring side plate									
U	Double rib inner ring									
S	Metric bore size of next smaller bearing									
None	Standard capacity									
6	High capacity series									
1	Narrow width									
5	Wide width									
7	Intermediate width									
0	Extra light series									
2	Light series									
3	Medium series									
9	Extra extra light series									
05	One-fifth of bore diameter (mm)									
G	Snap ring groove in outer ring O.D.									
GG	Two snap ring grooves in outer ring O.D.									
R	Snap ring groove in outer ring O.D. snap ring included									
RR	Two snap ring grooves in outer ring O.D.; snap rings included									
C	Plain cylindrical outer ring									
D	Single rib outer ring									
E	Double rib outer ring									
SN	Short single rib w/outer ring side plate									
T	Outer ring w/two retaining rings in I.D.									
U	Single rib outer ring, one retaining ring in I.D.									
A	Oversize O.D. outer ring									
H	Blind dowel hole in outer ring O.D.									
X	Segmented retainer									
M	Full complement (no retainer)									
V	Formed Steel Retainer									
B	Polymeric retainer									
Wxxx	This suffix specifies special bearing features									
None	Standard commercial clearance									
C2	Less than basic clearance									
C0	Basic clearance									
C3	Greater than basic clearance									
C4	Greater than C3 clearance									
C5	Greater than standard clearance (STANDARD FOR ASSEMBLY WITH "A" OUTER RING AND OMITTED IN MODEL NUMBER)									
Cxxx	Special specific clearance or range—i.e. /C002 or /C35-49 or C3549									

Cylindrical Roller Bearings Selection Guide

To select a bearing, determine the applied radial load, any applied thrust load, the desired Rating Life, and applicable operating conditions. The procedure shown here will aid in selecting a bearing to meet an L₁₀ design life. The formulas for calculating life expectancy should be used to determine the Rating Life L₁₀ for the bearing selected. Cylindrical roller bearings are available in various series with cylindrical bores for direct shaft mounting.

Bearings in several series may fulfill the L₁₀ life requirements. Speed limits, minimum shaft diameters, arrangement requirements and space limitations may be determining factors in final bearing selection. The selection procedures and rating formulas shown here are in agreement with The American Bearing Manufacturers Association Standards and ANSI/ABMA STD 11. Ratings are based on fatigue life. The Rating Life L₁₀ or fatigue life at 90% reliability is the usual basis for bearing selection. Cylindrical roller bearings are essentially radial bearings. Nevertheless those styles where integral

ribs are in the proper location on inner and outer rings will also support thrust loading. In fact, most such styles do support incidental, axial locating loads. Whenever applied thrust loading is known to exist, the guidelines given for Thrust Loads on the next page must be carefully followed.

Selection and life expectancy formulas shown here are also valid for inner ring and roller assemblies and for outer ring and roller assemblies provided they are run directly on bearing quality steel shafts or housings properly hardened and ground. To assure a satisfactory bearing application, fitting practice, mounting, lubrication, sealing, static rating, housing strength, operating conditions and maintenance must be considered.

Steps for Selection

Step 1

Determine an appropriate L₁₀ design life.

Type of service	Operating time, hours per year	Design life, years	L ₁₀ design life, hours
Light seasonal usage	500 to 750	3-5	3,000
Heavy seasonal usage	1,400 to 1,600	4-6	8,000
Industrial—8 hour shift	2,000	10	20,000
Industrial—16 hour shift	4,000	10	40,000
Industrial—continuous	8,700	10	80,000 to 100,000
Continuous—high reliability	—	—	120,000 to 300,000

Step 2

Determine a required $\left(\frac{C}{P}\right)$ from Table 1.

Step 3

Calculate the required C and select a cylindrical roller bearing.

$$P = Fr$$

required $C = \left(\frac{C}{P}\right)P$ using $\left(\frac{C}{P}\right)$ from Step 2.

Select a cylindrical roller bearing of the desired type having a Basic Load Rating C equal to or greater than the required C from the appropriate series. The life expectancy of other sizes and series of cylindrical roller bearings can be calculated. When thrust load is present, check the individual bearing thrust capacity and follow the requirements for lubrication under thrust conditions.

Step 4

Determine the permissible speed limit of the bearing through the following procedure:

Permissible speed limits are of practical value only when considered with other factors of bearing operation. Not every application functions satisfactorily at the listed speeds. Load, lubrication, and temperature factors influence the performance. Bearing operation at the listed speed limit demands excellent lubrication, moderate load, and reasonable temperature environment.

Permissible speed can be approximated from the limiting DN value, which is the product of the bearing bore in millimeters and the speed in RPM. The DN values shown below are nominal. For higher permissible speeds, consult Rexnord Bearing Division.

Bearing series	Limit of DN Value*
DN value = Bearing bore (mm) x speed (RPM)	
Series 1900, 1000, 1200, 1300 & 7300	
with segmented or polymeric retainer	450,000
with formed Steel Retainer	250,000
Series 5200, 6200, and 5300	
with segmented or polymeric retainer (5200, 5300 only)	330,000
with formed Steel Retainer	180,000
Full complement	150,000

*These values assume oil lubrication

Selection

Symbols for formulas:

- C = Basic Load Rating, pounds (or newtons)
- Co = static Load Rating, pounds (or newtons)
- Fr = radial load, pounds (or newtons)
- L10 = rating life, hours
- n = speed, revolutions per minute
- P = equivalent radial load, pounds (or newtons)

Table 1 • Relation of L10 life and speed to $\left(\frac{C}{P}\right)$

Bearing Life Hours L10	Ratio $\left(\frac{C}{P}\right)$									
	Speed, n									
	50	100	200	300	400	500	600	700	800	
3000	1.93	2.38	2.93	3.31	3.61	3.86	4.07	4.27	4.44	
4000	2.11	2.59	3.19	3.61	3.93	4.20	4.44	4.65	4.84	
5000	2.25	2.77	3.42	3.86	4.20	4.50	4.75	4.97	5.18	
6000	2.38	2.93	3.61	4.07	4.44	4.75	5.02	5.25	5.47	
8000	2.59	3.19	3.93	4.44	4.84	5.18	5.47	5.73	5.96	
10000	2.77	3.42	4.20	4.75	5.18	5.54	5.85	6.12	6.37	
12000	2.93	3.61	4.44	5.02	5.47	5.85	6.18	6.47	6.73	
14000	3.07	3.78	4.65	5.25	5.73	6.12	6.47	6.77	7.05	
16000	3.19	3.93	4.84	5.47	5.96	6.37	6.73	7.05	7.34	
18000	3.31	4.07	5.02	5.66	6.18	6.60	6.97	7.30	7.60	
20000	3.42	4.20	5.18	5.85	6.37	6.81	7.20	7.54	7.85	
25000	3.65	4.50	5.54	6.25	6.81	7.29	7.70	8.06	8.39	
30000	3.86	4.75	5.85	6.60	7.20	7.70	8.13	8.51	8.86	
35000	4.04	4.97	6.12	6.92	7.54	8.06	8.51	8.92	9.28	
40000	4.20	5.18	6.37	7.20	7.85	8.39	8.86	9.28	9.66	
45000	4.36	5.36	6.60	7.46	8.13	8.69	9.18	9.61	10.00	
50000	4.50	5.54	6.81	7.70	8.39	8.97	9.48	9.92	10.30	
60000	4.75	5.85	7.20	8.13	8.86	9.48	10.00	10.5	10.90	
70000	4.97	6.12	7.54	8.51	9.28	9.92	10.50	11.00	11.40	
80000	5.18	6.37	7.85	8.86	9.66	10.30	10.90	11.40	11.90	
90000	5.36	6.60	8.13	9.18	10.00	10.70	11.30	11.80	12.30	
100000	5.54	6.81	8.39	9.48	10.30	11.00	11.70	12.20	12.70	
150000	6.25	7.70	9.48	10.70	11.70	12.50	13.20	13.80	14.40	
200000	6.81	8.39	10.30	11.70	12.70	13.60	14.40	15.00	15.70	
	Speed, n									
	900	1000	1200	1500	1800	2400	3000	3600	6000	
3000	4.60	4.75	5.02	5.36	5.66	6.18	6.60	6.97	8.13	
4000	5.02	5.18	5.47	5.85	6.18	6.73	7.20	7.60	8.86	
5000	5.36	5.54	5.85	6.25	6.60	7.20	7.70	8.13	9.48	
6000	5.66	5.85	6.18	6.60	6.97	7.60	8.13	8.59	10.00	
8000	6.18	6.37	6.73	7.20	7.60	8.29	8.86	9.36	10.90	
10000	6.60	6.81	7.20	7.70	8.13	8.86	9.48	10.00	11.70	
12000	6.97	7.20	7.60	8.13	8.59	9.36	10.00	10.60	12.30	
14000	7.30	7.54	7.96	8.51	8.99	9.80	10.50	11.10	12.90	
16000	7.60	7.85	8.29	8.86	9.36	10.20	10.90	11.50	13.40	
18000	7.88	8.13	8.59	9.18	9.70	10.60	11.30	11.90	13.90	
20000	8.13	8.39	8.86	9.48	10.00	10.90	11.70	12.30	14.40	
25000	8.69	8.97	9.48	10.10	10.70	11.70	12.50	13.20	15.40	
30000	9.18	9.48	10.00	10.70	11.30	12.30	13.20	13.90	16.20	
35000	9.61	9.92	10.50	11.20	11.80	12.90	13.80	14.60	17.00	
40000	10.00	10.30	10.90	11.70	12.30	13.40	14.40	15.20	17.70	
45000	10.40	10.70	11.30	12.10	12.80	13.90	14.90	15.70	18.30	
50000	10.70	11.00	11.70	12.50	13.20	14.40	15.40	16.20	18.90	
60000	11.30	11.70	12.30	13.20	13.90	15.20	16.20	17.10	20.00	
70000	11.80	12.20	12.90	13.80	14.60	15.90	17.00	17.90	20.90	
80000	12.30	12.70	13.40	14.40	15.20	16.50	17.70	18.70	21.80	
90000	12.80	13.20	13.90	14.90	15.70	17.10	18.30	19.40	22.60	
100000	13.20	13.60	14.40	15.40	16.20	17.70	18.90	20.00	23.30	
150000	14.90	15.40	16.20	17.30	18.30	20.00	21.40	22.60	26.30	
200000	16.20	16.70	17.70	18.90	20.00	21.80	23.30	24.60	28.70	

Basic Formulas

$$\left(\frac{C}{P}\right) = \left(\frac{L_{10} \times n \times 60}{1,000,000}\right)^{3/10}$$

$$L_{10} = \frac{\left(\frac{C}{P}\right)^{10/3} \times 1,000,000}{n \times 60}$$

Life Expectancy

To calculate the Rating Life L10 of any pair of selected or trial bearings:

Step 1

Determine the equivalent radial load P.

$$P = F_r$$

Step 2 Calculate the ratio of the bearing Basic Load Rating C to the equivalent radial load.

$$\frac{C}{P}$$

Step 3

Approximate the bearing life from Table 1.

Thrust Loads

The integral guiding ribs on standard cylindrical roller bearing inner and outer rings will support limited thrust loads. In addition, special tolerances and processing can be used to substantially increase axial load capacity. In either case, excellent lubrication (preferably with an EP lubricant) and a stabilizing radial load are required. For standard bearings, the allowable thrust load is estimated as

$$TM = \frac{C_A}{3n^{0.3}}$$

- where
- TM Maximum allowable thrust load, pounds (or newtons)
 - CA Load rating C (pounds or newtons) of the narrowest series for the given annulus (O.D. and bore) at 33 1/3 RPM and 500L10 hours.
 - n Operating speed, RPM

In addition, the thrust load should be no greater than 25% of the radial load. Where application conditions exceed either of these limits, Rexnord Bearing Division should be consulted.

Life Adjustment

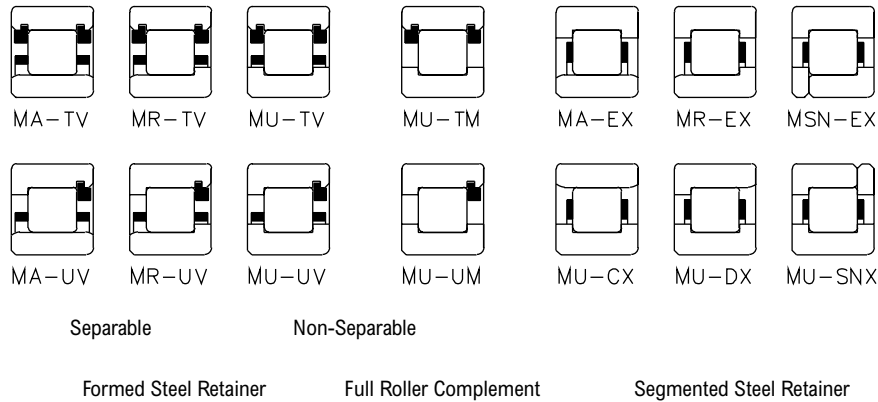
The Rating Life, L10, may be modified for some applications in accordance with the formula

$$L_n = a_1 a_2 a_3 L_{10}$$

- where
- Ln = Adjusted life for (100-n) % reliability,
 - a1 = Life adjustment factor for reliability
 - a2 = Life adjustment factor for material and processing
 - a3 = Life adjustment factor for operating conditions.

For most normal applications, all factors will be taken as 1, and the Rating Life used as the selection basis or life estimate. In addition, as long as standard catalog bearings are used, a2 will be normally set equal to one. The factor a3 covers such things as lubrication, misalignment, and temperature. Some conditions that could yield a3 significantly different than unity include speeds less than 20000 DN or greater than 200000 DN, temperatures below -40°F (-40°C) or above 275°F (135°C), or misalignment greater than 0.0005 radians. For other possible conditions, as well as additional information on life adjustment factors, consult Rexnord Bearing Division.

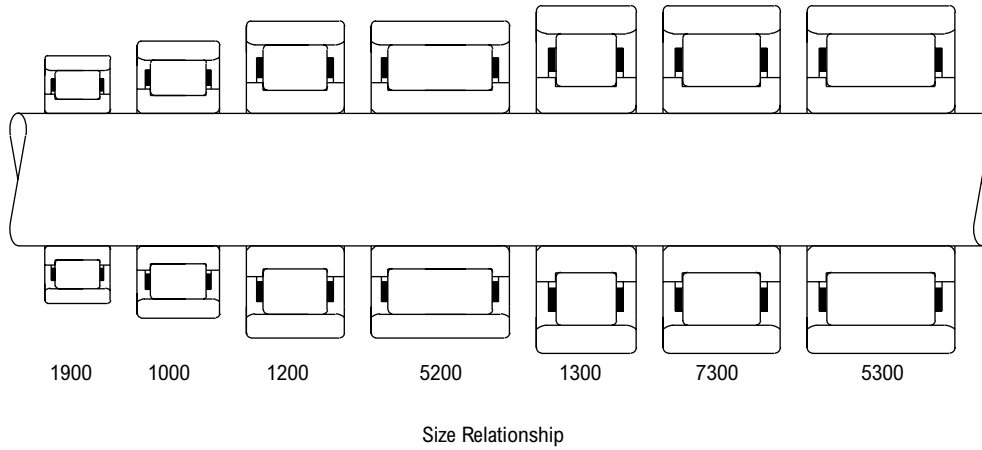
Ratings 25 mm, 30 mm, 35 mm, 40 mm Bores



Load Ratings (pounds/newtons)

Basic Bearing Number	Formed Steel Retainer						Segmented Steel Retainer			Full Roller Complement		
	Separable			Non-separable			C Basic Load Rating	Bearing Capacity 500 RPM, 3000 Hrs. L10	Co Basic Static Load Rating	C Basic Load Rating	Bearing Capacity 500 RPM, 3000 Hrs. L10	Co Basic Static Load Rating
	C Basic Load Rating	Bearing Capacity 500 RPM, 3000 Hrs. L10	Co Basic Static Load Rating	C Basic Load Rating	Bearing Capacity 500 RPM, 3000 Hrs. L10	Co Basic Static Load Rating						
1205	4330	1120	5220	5280	1370	5220	6170	1600	6430	7020	1820	7630
	19200	4980	23200	23500	6080	23200	27500	7110	28600	31200	8090	33900
5205	5930	1540	7830	7240	1880	7830	8460	2190	9640	9620	2490	11400
	26400	6830	34800	32200	8340	34800	37600	9750	42900	42800	11100	50900
1305	6310	1630	6690	7710	2000	6690	8840	2290	8030	9920	2570	9370
	28100	7270	29800	34300	8880	29800	39300	10200	35700	44100	11400	41700
7305	8070	2090	9180	9850	2550	9180	11300	2930	11000	12700	3280	12800
	35900	9300	40800	43800	11400	40800	50200	13000	49000	56400	14600	57100
5305	9720	2520	11700	11900	3070	11700	13600	3530	14000	15300	3960	16300
	43200	11200	51900	52800	13700	51900	60500	15700	62300	68100	17600	72500
1206	5990	1550	7170	7320	1900	7170	8150	2110	8270	9340	2420	9930
	26700	6910	31900	32600	8430	31900	36200	9390	36800	41600	10800	44200
5206	9040	2340	12200	11000	2860	12200	12300	3180	14000	14100	3650	16800
	40200	10400	54100	49100	12700	54100	54700	14200	62500	62700	16200	74900
1306	7970	2060	9270	9730	2520	9270	10300	2680	10000	12100	3130	12400
	35400	9180	41200	43300	11200	41200	45900	11900	44700	53700	13900	55000
7306	10500	2720	13200	12800	3320	13200	13600	3530	14400	15900	4130	17700
	46800	12100	58900	57100	14800	58900	60600	15700	63800	70700	18400	78700
5306	12800	3320	17100	15700	4060	17100	16600	4310	18500	19400	5030	22800
	57000	14800	76100	69600	18000	76100	74000	19200	82400	86400	22400	101000
1207	6840	1770	8030	8350	2160	8030	9290	2410	9270	10700	2760	11100
	30400	7870	35700	37100	9610	35700	41300	10700	41200	47400	12300	49500
5207	11300	2920	15300	13800	3570	15300	15300	3970	17700	17600	4560	21200
	50200	13000	68100	61300	15900	68100	68300	17700	78600	78300	20300	94300
1307	9840	2550	12000	12000	3110	12000	13500	3490	14000	15600	4040	17000
	43800	11300	53400	53400	13800	53400	60000	15500	62400	69400	18000	75700
7307	13800	3580	18700	16900	4380	18700	17900	4630	20100	20700	5350	24400
	61500	15900	83100	75100	19500	83100	79400	20600	89500	91900	23800	109000
5307	15900	4120	22400	19400	5030	22400	20500	5320	24100	23800	6150	29200
	70800	18300	99400	86400	22400	99400	91400	23700	107000	106000	27400	130000
1208	8270	2140	10200	10100	2620	10200	11200	2890	11600	12700	3290	13800
	36800	9530	45300	44900	11600	45300	49700	12900	51800	56500	14600	61500
5208	14300	3710	20700	17500	4530	20700	19400	5010	23600	22000	5700	28000
	63800	16500	91900	77900	20200	91900	86100	22300	105000	97900	25400	125000
1308	12600	3260	15200	15400	3980	15200	16300	4230	16400	19100	4940	20200
	56000	14500	67500	68400	17700	67500	72600	18800	73100	84800	22000	90000
7308	17900	4630	23800	21800	5660	23800	23200	6010	25800	27100	7020	31800
	79600	20600	106000	97200	25200	106000	103000	26700	115000	121000	31200	141000
5308	20000	5190	27600	24500	6330	27600	26000	6720	29900	30300	7860	36800
	89100	23100	123000	109000	28200	123000	115000	29900	133000	135000	35000	163000

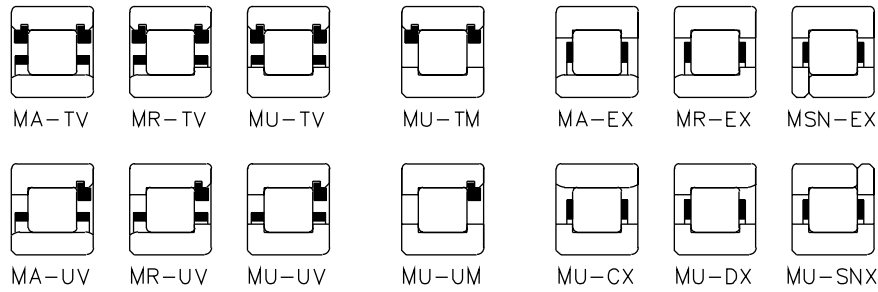
Ratings 45 mm, 50 mm, 55 mm Bores



Load Ratings (pounds/newtons)

Basic Bearing Number	Formed Steel Retainer						Segmented Steel Retainer			Full Roller Complement		
	Separable			Non-separable			C Basic Load Rating	Bearing Capacity 500 RPM, 3000 Hrs. L10	Co Basic Static Load Rating	C Basic Load Rating	Bearing Capacity 500 RPM, 3000 Hrs. L10	Co Basic Static Load Rating
	C Basic Load Rating	Bearing Capacity 500 RPM, 3000 Hrs. L10	Co Basic Static Load Rating	C Basic Load Rating	Bearing Capacity 500 RPM, 3000 Hrs. L10	Co Basic Static Load Rating						
1209	9670	2500	12900	11800	3060	12900	12900	3340	14500	14500	3750	16900
5209	43000	11100	57300	52500	13600	57300	57400	14900	64500	64400	16700	75200
	15600	4030	23800	19000	4920	23800	20800	5380	26700	23300	6040	31200
1309	69200	17900	106000	84500	21900	106000	92300	23900	119000	104000	26800	139000
	15900	4120	20400	19400	5040	20400	20600	5320	22000	23800	6160	26700
7309	70800	18300	90900	86500	22400	90900	91400	23700	97900	106000	27400	119000
	20300	5260	28000	24800	6430	28000	26200	6790	30100	30300	7860	36600
5309	90400	23400	124000	110000	28600	124000	117000	30200	134000	135000	35000	163000
	24800	6440	36200	30300	7860	36200	32100	8310	39000	37100	9610	47400
1010	111000	28600	161000	135000	35000	161000	143000	37000	174000	165000	42700	211000
	8840	2290	11100
1210	39300	10200	49400
	9830	2550	13600	12000	3110	13600	13000	3380	15200	15100	3900	18400
5210	43700	11300	60600	53400	13800	60600	58000	15000	67700	67000	17300	82000
	15800	4100	25100	19300	5000	25100	21000	5440	28100	24200	6280	34000
1310	70400	18200	112000	85900	22300	112000	93400	24200	125000	108000	27900	151000
	18600	4810	24000	22700	5870	24000	23900	6200	25900	27700	7170	31400
7310	82500	21400	107000	101000	26100	107000	107000	27600	115000	123000	31900	140000
	24000	6220	33500	29300	7590	33500	31000	8030	36000	35900	9290	43800
5310	107000	27700	149000	130000	33800	149000	138000	35700	160000	159000	41300	195000
	29300	7600	43300	35800	9280	43300	37900	9810	46600	43800	11300	56600
1911	131000	33800	193000	159000	41300	193000	169000	43600	207000	195000	50500	252000
	6960	1800	9570
1011	31000	8020	42600
	11200	2890	14300
1211	49800	12900	63400
	11700	3040	16400	1430	3710	16400	15600	4030	18400	18000	4650	22300
5211	52200	13500	73200	63700	16500	73200	69200	17900	81800	79900	20700	99000
	19200	4960	30900	23400	6060	30900	25400	6590	34600	29400	7600	41900
1311	85300	22100	138000	104000	27000	138000	113000	29300	154000	131000	33800	186000
	21900	5680	28800	26800	6930	28800	26800	6930	28800	31000	8020	35000
7311	97500	25300	128000	119000	30800	128000	119000	30800	128000	138000	35700	156000
	29300	7590	41800	35800	9270	41800	35800	9270	41800	41400	10700	50800
5311	130000	33800	186000	159000	41200	186000	159000	41200	186000	184000	47700	226000
	38100	9860	58600	46500	12000	58600	46500	12000	58600	53800	13900	71100
	169000	43900	260000	207000	53500	260000	207000	53500	260000	239000	61900	316000

Ratings 60 mm, 65 mm, 70 mm Bores



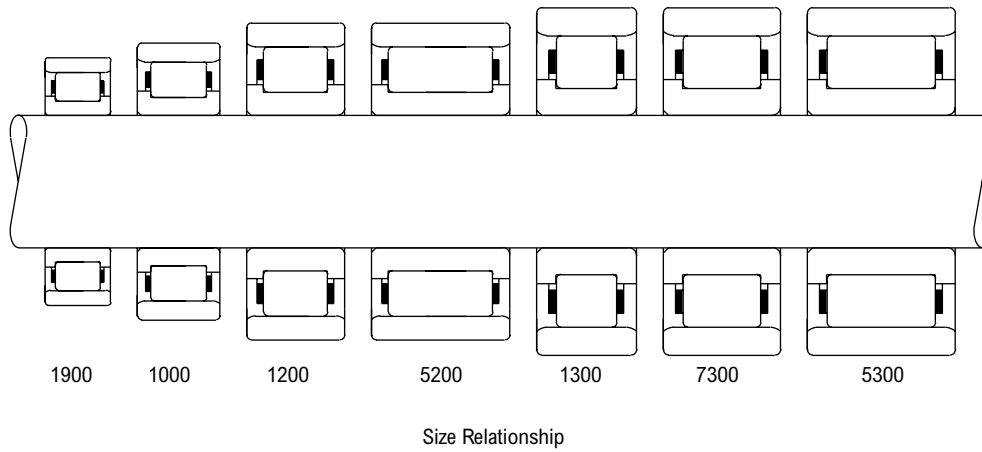
Separable Non-Separable

Formed Steel Retainer Full Roller Complement Segmented Steel Retainer

Load Ratings (pounds/newtons)

Basic Bearing Number	Formed Steel Retainer						Segmented Steel Retainer			Full Roller Complement		
	Separable			Non-separable			C Basic Load Rating	Bearing Capacity 500 RPM, 3000 Hrs. L10	Co Basic Static Load Rating	C Basic Load Rating	Bearing Capacity 500 RPM, 3000 Hrs. L10	Co Basic Static Load Rating
	C Basic Load Rating	Bearing Capacity 500 RPM, 3000 Hrs. L10	Co Basic Static Load Rating	C Basic Load Rating	Bearing Capacity 500 RPM, 3000 Hrs. L10	Co Basic Static Load Rating						
1912	7200	1870	10300
	32000	8300	45600
1012	11700	3040	15600
	52200	13500	69200
1212	14500	3760	19600	17700	4590	19600	19400	5020	22100	21700	5630	25800
	64600	16700	87400	78900	20400	87400	86100	22300	98300	96700	25000	115000
5212	24700	6390	38900	30100	7800	38900	32900	8520	43700	36900	9570	51000
	110000	28400	173000	134000	34700	173000	146000	37900	194000	164000	42600	227000
1312	24900	6450	32800	30400	7880	32800	32100	8330	35300	37200	9630	42900
	111000	28700	146000	135000	35500	146000	143000	37000	157000	165000	42800	191000
7312	32600	8450	46400	39800	10300	46400	42100	10900	50000	48700	12600	60700
	145000	37600	206000	177000	45900	206000	187000	48500	222000	217000	56100	270000
5312	43900	11400	68000	53600	13900	68000	56600	14700	73200	65500	17000	88900
	195000	50500	302000	238000	61700	302000	252000	65200	326000	291000	75500	395000
1913	7600	1970	11200
	33800	8750	50000
1013	12000	3100	16300
	53200	13800	72400
1213	16800	4360	24400	20500	5320	24400	21400	5540	25800	24700	6390	31200
	74800	19400	109000	91400	23700	109000	95100	24600	115000	110000	28400	139000
5213	26800	6930	44400	32700	8460	44400	34000	8810	46800	39300	10200	56700
	119000	30800	197000	145000	37600	197000	151000	39200	208000	175000	45200	252000
1313	30800	7970	41900	37600	9730	41900	37600	9730	41900	43400	11300	50900
	137000	35400	186000	167000	43300	186000	167000	43300	186000	193000	50100	226000
7313	39200	10100	57200	47800	12400	57200	47800	12400	57200	55300	14300	69400
	174000	45100	254000	213000	55100	254000	213000	55100	254000	246000	63700	309000
5313	54900	14200	88200	67000	17300	88200	67000	17300	88200	77500	20100	107000
	244000	63200	392000	298000	77200	392000	298000	77200	392000	345000	89300	476000
1914	10900	2810	15800
	48300	12500	70400
1014	14600	3770	18600
	64800	16800	82800
1214	18100	4700	26300	22100	5730	26300	24100	6230	29400	27900	7190	35600
	80600	20900	117000	98500	25500	117000	107000	27700	131000	124000	32000	158000
5214	29900	7750	50100	36600	9470	50100	39700	10300	56000	45900	11900	67800
	133000	34500	223000	163000	42100	223000	177000	45800	249000	204000	52800	302000
1314	35300	9130	48800	43000	11100	48800	43000	11100	48800	49800	12900	59200
	157000	40600	217000	191000	49600	217000	191000	49600	217000	221000	57400	263000
7314	43800	11300	64400	53500	13800	64400	53500	13800	64400	61800	16000	78200
	195000	50400	287000	238000	61600	287000	238000	61600	287000	275000	71300	348000
5314	57600	14900	91700	70400	18200	91700	70400	18200	91700	81400	21100	111000
	256000	66400	408000	313000	81100	408000	313000	81100	408000	362000	93800	495000

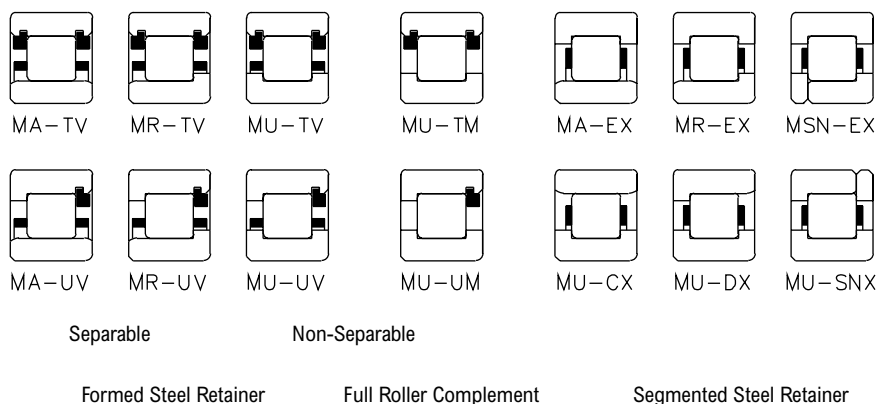
Ratings 75 mm, 80 mm, 85 mm Bores



Load Ratings (pounds/newtons)

Basic Bearing Number	Formed Steel Retainer						Segmented Steel Retainer			Full Roller Complement		
	Separable			Non-separable			C Basic Load Rating	Bearing Capacity 500 RPM, 3000 Hrs. L10	Co Basic Static Load Rating	C Basic Load Rating	Bearing Capacity 500 RPM, 3000 Hrs. L10	Co Basic Static Load Rating
	C Basic Load Rating	Bearing Capacity 500 RPM, 3000 Hrs. L10	Co Basic Static Load Rating	C Basic Load Rating	Bearing Capacity 500 RPM, 3000 Hrs. L10	Co Basic Static Load Rating						
1915	11200	2910	16900
.....	50000	13000	75200
1015	15300	3970	20300
.....	68200	17700	90300
1215	18800	4880	28000	23000	5960	28000	24900	6450	31100	28600	7390	37400
.....	83800	21700	125000	102000	26500	125000	111000	28700	139000	157000	32900	166000
5215	32500	8430	56600	39700	10300	56600	43000	11100	62900	49300	12800	75500
.....	145000	37500	252000	177000	45800	252000	191000	49500	280000	219000	56800	336000
1315	36600	9470	49700	44600	11600	49700	44600	11600	49700	51600	13400	60300
.....	163000	42100	221000	199000	51400	221000	199000	51400	221000	230000	59500	268000
7315	48500	12600	71500	59300	15400	71500	59300	15400	71500	68600	17800	86900
.....	216000	55900	318000	264000	68300	318000	264000	68300	318000	305000	79000	386000
5315	70900	18400	116000	86600	22400	116000	86600	22400	116000	100000	25900	141000
.....	315000	81700	518000	385000	99800	518000	385000	99800	518000	446000	115000	629000
1916	11600	3010	18000
.....	51700	13400	80000
1016	19200	4970	25800
.....	85300	22100	115000
1216	20600	5330	30100	25100	6500	30100	27200	7040	33400	30200	7820	38400
.....	91500	23700	134000	112000	28900	134000	121000	31300	149000	134000	34800	171000
5216	36800	9540	63700	45000	11600	63700	48700	12600	70700	54000	14000	81300
.....	164000	42400	283000	200000	51800	283000	216000	56100	315000	240000	62300	362000
1316	41500	10800	57300	50700	13100	57300	50700	13100	57300	58700	15200	69600
.....	185000	47900	255000	226000	58400	255000	226000	58400	255000	261000	67600	309000
7316	55100	14300	82400	67300	17400	82400	67300	17400	82400	77900	20200	100000
.....	245000	63500	367000	299000	77500	367000	299000	77500	367000	346000	89700	445000
5316	73300	19000	119000	89400	23200	119000	89400	23200	119000	103000	26800	144000
.....	326000	84400	528000	398000	103000	528000	398000	103000	528000	460000	119000	642000
1917	13700	3550	20900
.....	60900	15800	93100
1017	19700	5100	27000
.....	87500	22700	120000
1217	24800	6410	36700	30200	7830	36700	31500	8160	38700	36300	9410	46900
.....	110000	28500	163000	134000	34800	163000	140000	36300	172000	162000	41900	208000
5217	45300	11700	79700	55300	14300	79700	57600	14900	84100	66400	17200	102000
.....	201000	52200	354000	246000	63700	354000	356000	66300	374000	296000	76500	453000
1317	44600	11500	61200	54400	14100	61200	54400	14100	61200	63000	16300	74300
.....	198000	51300	272000	242000	62700	272000	242000	62700	272000	280000	72500	330000
7317	61700	16000	92900	75400	19500	92900	75400	19500	92900	87200	22600	113000
.....	275000	71100	413000	335000	86800	413000	335000	86900	413000	388000	100000	502000
5317	86300	22400	143000	105000	27300	143000	105000	27300	143000	122000	31600	174000
.....	384000	99500	636000	469000	121000	636000	469000	121000	636000	542000	140000	773000

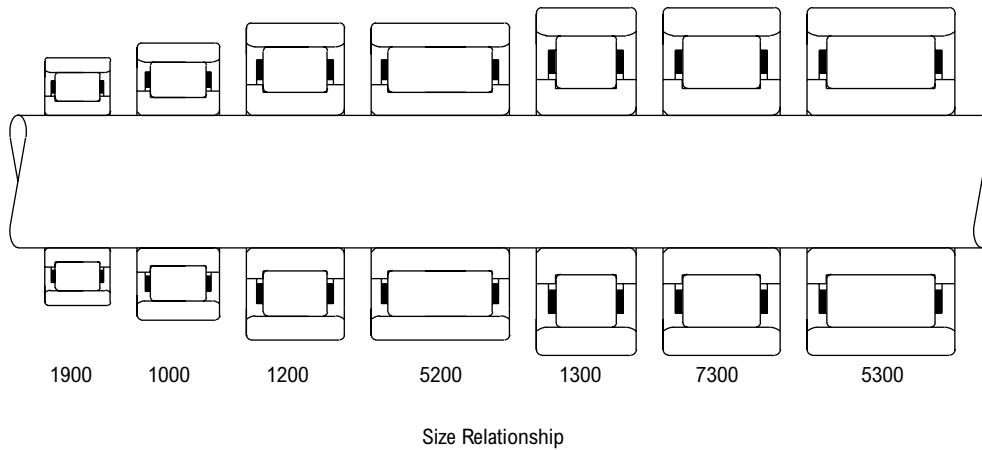
Ratings 90 mm, 95 mm, 100 mm Bores



Load Ratings (pounds/newtons)

Basic Bearing Number	Formed Steel Retainer						Segmented Steel Retainer			Full Roller Complement		
	Separable			Non-separable			C Basic Load Rating	Bearing Capacity 500 RPM, 3000 Hrs. L10	Co Basic Static Load Rating	C Basic Load Rating	Bearing Capacity 500 RPM, 3000 Hrs. L10	Co Basic Static Load Rating
	C Basic Load Rating	Bearing Capacity 500 RPM, 3000 Hrs. L10	Co Basic Static Load Rating	C Basic Load Rating	Bearing Capacity 500 RPM, 3000 Hrs. L10	Co Basic Static Load Rating						
1918	14200	3670	22200
	6300	16300	98900
1018	24900	6440	33500
	111000	28600	149000
1218	28700	7440	42600	35100	9090	42600	38100	9880	47600	42600	11000	55100
	128000	33100	190000	156000	40400	190000	170000	43900	212000	189000	49000	245000
5218	51000	13200	89100	62300	16100	89100	67700	17500	99600	75500	19600	115000
	227000	58700	396000	277000	71700	396000	301000	78000	443000	336000	87000	513000
1318	52600	13600	74200	64200	16600	74200	64200	16600	74200	74200	19200	90100
	234000	60600	330000	285000	73900	330000	285000	73900	330000	330000	85500	401000
7318	69000	17900	105000	84300	21800	105000	84300	21800	105000	97500	25300	128000
	307000	79500	469000	375000	97100	469000	375000	97100	469000	434000	112000	569000
5318	88400	22900	145000	108000	27900	145000	108000	27900	145000	125000	32300	176000
	393000	102000	644000	480000	124000	644000	480000	124000	644000	556000	144000	783000
1919	14600	3790	23600
	65100	16900	105000
1019	25500	6600	35100
	113000	29400	156000
1219	33400	8650	50000	40800	10600	50000	42600	11000	53000	49500	12800	64700
	149000	38500	222000	181000	47000	222000	189000	49000	236000	220000	57000	288000
5219	58500	15200	103000	71400	18500	103000	74600	19300	109000	86700	22400	133000
	260000	67400	457000	318000	82300	457000	332000	85900	484000	386000	99800	592000
1319	55300	14300	80500	67600	17500	80500	67600	17500	80500	77400	20100	96600
	246000	63700	358000	300000	77800	358000	300000	77800	358000	344000	89200	430000
7319	75800	19600	121000	92600	24000	121000	92600	24000	121000	106000	27500	145000
	337000	87400	537000	412000	107000	537000	412000	107000	537000	472000	122000	644000
5319	93000	24100	157000	114000	29400	157000	114000	29400	157000	130000	33700	188000
	414000	107000	698000	505000	131000	698000	505000	131000	698000	579000	150000	838000
1920	17300	4470	25600
	76800	19900	114000
1020	26100	6760	36700
	116000	30100	163000
1220	36500	9470	54800	44600	11600	54800	46600	12100	58000	54100	14000	70900
	163000	42100	244000	198000	51400	244000	207000	53700	258000	241000	62400	315000
5220	65900	17100	117000	80500	20800	117000	84000	21800	124000	97700	25300	151000
	293000	76000	520000	358000	92700	520000	374000	96800	551000	434000	113000	674000
1320	60600	15700	88300	74000	19200	88300	74000	19200	88300	84800	22000	106000
	270000	69800	393000	329000	85300	393000	329000	85300	393000	377000	97700	472000
7320	82500	21400	131000	101000	26100	131000	101000	26100	131000	115000	29900	157000
	367000	95000	584000	448000	116000	584000	448000	116000	584000	513000	133000	700000
5320	111000	28700	192000	135000	35100	192000	135000	35100	192000	155000	40200	231000
	493000	128000	855000	602000	156000	855000	602000	156000	855000	691000	179000	1030000

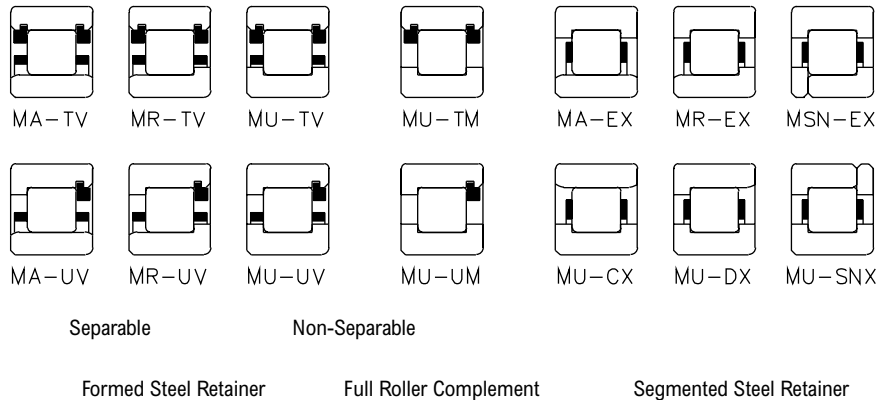
Ratings 105 mm, 110 mm, 120 mm Bores



Load Ratings (pounds/newtons)

Basic Bearing Number	Formed Steel Retainer						Segmented Steel Retainer			Full Roller Complement		
	Separable			Non-separable			C Basic Load Rating	Bearing Capacity 500 RPM, 3000 Hrs. L10	Co Basic Static Load Rating	C Basic Load Rating	Bearing Capacity 500 RPM, 3000 Hrs. L10	Co Basic Static Load Rating
	C Basic Load Rating	Bearing Capacity 500 RPM, 3000 Hrs. L10	Co Basic Static Load Rating	C Basic Load Rating	Bearing Capacity 500 RPM, 3000 Hrs. L10	Co Basic Static Load Rating						
1921	17900	4650	27300
.....	79800	20700	121000
1021	31000	8040	45000
.....	138000	35800	200000
1221	38600	9990	57800	47100	12200	57800	49200	12700	61200	57200	14800	74800
.....	172000	44400	257000	210000	54300	257000	219000	56600	272000	254000	65800	333000
5221	73400	19000	132000	89600	23200	132000	93600	24200	140000	109000	28200	171000
.....	327000	84600	588000	399000	103000	588000	416000	108000	622000	484000	125000	760000
1321	71700	18600	108000	87500	22700	108000	87500	22700	108000	100000	26000	129000
.....	319000	82500	479000	389000	101000	479000	389000	101000	479000	446000	116000	575000
7321	90500	23400	145000	110000	28600	145000	110000	28600	145000	127000	32800	174000
.....	403000	104000	647000	491000	127000	647000	491000	127000	647000	563000	146000	776000
5321	118000	30500	204000	144000	37200	204000	144000	37200	204000	165000	42700	244000
.....	523000	136000	906000	639000	165000	906000	639000	165000	906000	734000	190000	1090000
1922	18200	4720	28200
.....	81200	21000	125000
1022	35300	9150	50600
.....	157000	40700	225000
1222	43600	11300	67300	53200	13800	67300	55400	14400	71100	61900	16000	82300
.....	194000	50200	299000	237000	61300	299000	247000	63900	316000	275000	71300	366000
5222	79900	20700	147000	97600	25300	147000	102000	26300	155000	113000	29400	179000
.....	356000	92100	653000	434000	112000	653000	452000	117000	689000	505000	131000	798000
1322	72800	18900	107000	88900	23000	107000	88900	23000	107000	102000	26400	129000
.....	324000	83800	477000	395000	102000	477000	395000	102000	477000	453000	117000	572000
7322	99800	25800	161000	122000	31500	161000	122000	31500	161000	140000	36200	193000
.....	444000	115000	715000	542000	140000	715000	542000	140000	715000	621000	161000	858000
5322	138000	35700	244000	169000	43600	244000	169000	43600	244000	193000	50000	293000
.....	614000	159000	1090000	750000	194000	1090000	750000	194000	1090000	859000	223000	1300000
1924	23800	6160	37300
.....	106000	27400	166000
1024	37000	9590	55100
.....	165000	42700	245000
1224	49400	12800	77900	60300	15600	77900	62800	16300	82300	72500	18800	99600
.....	220000	56900	347000	268000	69500	347000	279000	72400	366000	323000	83500	443000
5224	97200	25200	186000	119000	30700	186000	124000	32000	196000	143000	36900	238000
.....	432000	112000	827000	528000	137000	827000	550000	142000	873000	634000	164000	1060000
1324	84600	21900	126000	103000	26700	126000	103000	26700	126000	118000	30700	151000
.....	376000	97400	562000	459000	119000	562000	459000	119000	562000	527000	136000	674000
7324	118000	30500	193000	144000	37300	193000	144000	37300	193000	165000	42700	232000
.....	524000	136000	861000	640000	166000	861000	640000	166000	861000	734000	190000	1030000
5324	170000	44100	310000	208000	53900	310000	208000	53900	310000	238000	61700	373000
.....	757000	196000	1380000	925000	240000	1380000	925000	240000	1380000	1060000	275000	1660000

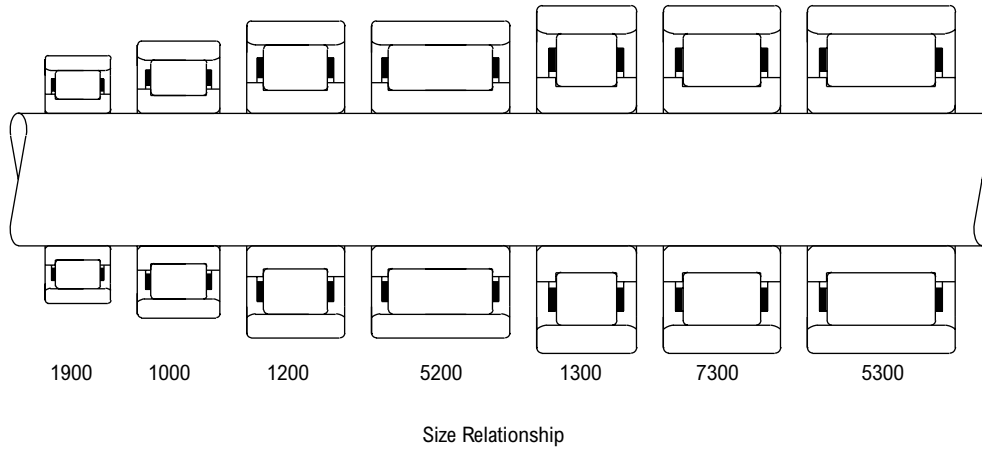
Ratings 130 mm, 140 mm, 150 mm Bores



Load Ratings (pounds/newtons)

Basic Bearing Number	Formed Steel Retainer						Segmented Steel Retainer			Full Roller Complement		
	Separable			Non-separable			C Basic Load Rating	Bearing Capacity 500 RPM, 3000 Hrs. L10	Co Basic Static Load Rating	C Basic Load Rating	Bearing Capacity 500 RPM, 3000 Hrs. L10	Co Basic Static Load Rating
	C Basic Load Rating	Bearing Capacity 500 RPM, 3000 Hrs. L10	Co Basic Static Load Rating	C Basic Load Rating	Bearing Capacity 500 RPM, 3000 Hrs. L10	Co Basic Static Load Rating						
1926	30100	7800	47600
	134000	34700	212000
1026	47500	12300	69100
	211000	54700	307000
1226	55300	14300	85200	67500	17500	85200	67500	17500	85200	78500	20300	104000
	246000	63700	379000	300000	77800	379000	300000	77800	379000	349000	90400	463000
5226	104000	26900	192000	127000	32800	192000	127000	32800	192000	147000	38200	234000
	462000	120000	852000	564000	146000	852000	564000	146000	852000	655000	170000	1040000
1326	100000	25900	151000	122000	31700	151000	122000	31700	151000	140000	36300	182000
	446000	115000	674000	544000	141000	674000	544000	141000	674000	624000	162000	808000
7326	138000	35700	228000	168000	43600	228000	168000	43600	228000	193000	50000	274000
	613000	159000	1020000	749000	194000	1020000	749000	194000	1020000	858000	222000	1220000
5326	190000	49300	346000	232000	60200	346000	232000	60200	346000	267000	69000	415000
	847000	219000	1540000	1030000	268000	1540000	1030000	268000	1540000	1190000	307000	1850000
1928	31100	8060	50800
	138000	35900	226000
1028	49900	12900	75100
	222000	57400	334000
1228	61700	16000	95000	75300	19500	95000	75300	19500	95000	87600	22700	116000
	274000	71100	422000	335000	86800	422000	335000	86800	422000	390000	101000	516000
5228	129000	33400	244000	157000	40700	244000	157000	40700	244000	183000	47300	299000
	573000	148000	1090000	699000	181000	1090000	699000	181000	1090000	813000	211000	1330000
1328	111000	28800	170000	136000	35200	170000	136000	35200	170000	156000	40400	204000
	495000	128000	756000	605000	157000	756000	605000	157000	756000	693000	180000	907000
7328	158000	40800	266000	192000	49800	266000	192000	49800	266000	221000	57100	319000
	701000	182000	1180000	856000	222000	1180000	856000	222000	1180000	981000	254000	1420000
5328	209000	54200	383000	256000	66200	383000	256000	66200	383000	293000	75900	460000
	931000	241000	1700000	1140000	295000	1700000	1140000	295000	1700000	1300000	338000	2050000
1930	41800	10800	68600
	186000	48100	305000
1030	56700	14700	85800
	252000	65300	382000
1230	71000	18400	111000	86700	22500	111000	86700	22500	111000	101000	26100	135000
	316000	81800	492000	386000	99900	492000	386000	99900	492000	448000	116000	601000
5230	150000	38900	289000	183000	47500	289000	183000	47500	289000	213000	55200	354000
	668000	173000	1290000	815000	211000	1290000	815000	211000	1290000	948000	245000	1570000

Ratings 160 mm, 170 mm, 180 mm, 190 mm, 200 mm Bores



Load Ratings (pounds/newtons)

Basic Bearing Number	Formed Steel Retainer						Segmented Steel Retainer			Full Roller Complement		
	Separable			Non-separable			C Basic Load Rating	Bearing Capacity 500 RPM, 3000 Hrs. L10	Co Basic Static Load Rating	C Basic Load Rating	Bearing Capacity 500 RPM, 3000 Hrs. L10	Co Basic Static Load Rating
	C Basic Load Rating	Bearing Capacity 500 RPM, 3000 Hrs. L10	Co Basic Static Load Rating	C Basic Load Rating	Bearing Capacity 500 RPM, 3000 Hrs. L10	Co Basic Static Load Rating						
1932	43200	11200	73100
1032	192000	49800	325000
1232	78300	20300	120000	95600	24800	120000	99800	25800	127000	112000	29000	148000
5232	348000	90200	534000	425000	110000	534000	444000	115000	565000	498000	129000	660000
1934	289000	74800	444000
1034	222000	57500	356000	249000	64600	415000
1234	174000	45100	336000	213000	55100	336000	988000	256000	1580000	1110000	287000	1850000
5234	775000	201000	1490000	946000	245000	1490000	43700	11300	75500
1936	195000	50400	336000
1036	81400	21100	130000
1236	95700	24800	149000	117000	30300	149000	362000	93800	577000
5236	426000	110000	664000	520000	135000	664000	122000	31600	158000	137000	35500	184000
1938	202000	52400	391000	247000	64000	391000	543000	141000	703000	609000	158000	820000
1038	900000	233000	1740000	1100000	285000	1740000	258000	66800	414000	290000	75000	483000
1238	195000	50600	379000	239000	61800	379000	1150000	297000	1840000	1290000	334000	2150000
5238	870000	225000	1690000	1060000	275000	1690000	56000	14500	93700
1940	249000	64500	417000
1040	97900	25400	154000
1240	99600	25800	159000	122000	31500	159000	436000	113000	685000
5240	443000	115000	708000	541000	140000	708000	122000	31500	159000	136000	35300	186000
1942	195000	50600	379000	239000	61800	379000	541000	140000	708000	607000	157000	826000
1042	870000	225000	1690000	1060000	275000	1690000	239000	61800	379000	268000	69400	442000
1242	195000	50600	379000	239000	61800	379000	1060000	275000	1690000	1190000	309000	1970000
5242	870000	225000	1690000	1060000	275000	1690000	56800	14700	97000
1944	253000	65500	431000
1044	100000	26000	161000
1244	143200	37000	239400	175400	45600	239400	446000	115000	716000
5244	637000	164900	1065000	780000	203000	1065000	190600	49300	267700	205000	53000	299000
1946	242000	62800	489000	296000	76600	489000	848000	219500	1191000	912000	236000	1330000
1046	1080000	279000	2170000	1320000	341000	2170000	296000	76600	489000	332000	86000	570000
1246	123000	31900	201000	150000	38900	201000	1320000	341000	2170000	1480000	383000	254000
5246	547000	142000	893000	668000	173000	893000	73700	19100	125000
1948	270000	69900	551000	329000	85300	551000	328000	84900	556000
1048	1200000	311000	2450000	1460000	379000	2450000	121000	31300	193000
1248	123000	31900	201000	150000	38900	201000	538000	139000	859000
5248	547000	142000	893000	668000	173000	893000	150000	38900	201000	175000	45200	246000
1950	270000	69900	551000	329000	85300	551000	668000	173000	893000	777000	201000	1090000
1050	1200000	311000	2450000	1460000	379000	2450000	329000	85300	551000	383000	99200	673000
1250	1200000	311000	2450000	1460000	379000	2450000	1460000	379000	2450000	1700000	441000	2990000

Shaft Bearing Seat Diameters

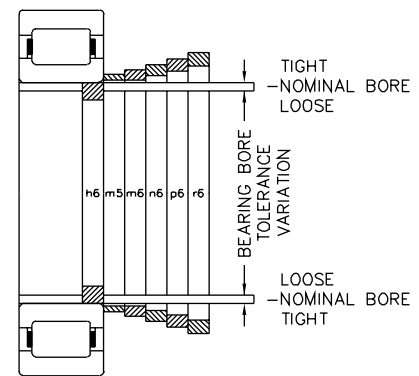
Bearing bore tolerances are in accordance with the system of tolerancing established by the International Standards Organization (ISO) and adopted by the American Bearing Manufacturers Association (ABMA) and the American National Standards Institute (ANSI).

A system of limits and fits has been established by ISO for shafts. A portion of this system has been adopted by ABMA to provide flexibility in selecting shaft fits. Shaft fits are designated by a lower case letter and a number, such as h6. The letter indicates the location of the shaft tolerance limits with respect to the nominal bearing bore. The number indicates the size of the tolerance zone.

Shaft fits recommended for various types of applications are listed in the table at right. A graphic relationship of various shaft fits is illustrated in the figure at the left.

Many factors influence the proper fit of the bearing inner ring on a shaft. The magnitude of the load and its direction with respect to bearing inner or outer rings are generally the first factors considered in shaft fit selection. The effects of other factors such as vibration, shock, temperature, speed, etc., are of secondary importance but sometimes need to be considered. Where assembly or disassembly requirements are of prime importance special shaft fits may be required.

Appropriate diameter shafting is determined (as shown) from the tables below.



Class of Fit and Shaft Diameters (inches/μm)

Bearing Series, 1000, 1200, 1300, 1900, 5200, 5300, 7300	Nominal Bearing Bore And Shaft Diameter		Bearing Bore Tolerance ▲	Bearing/Shaft Diameter Fits ▲				
				H6		M5		
				Tolerance		Tolerance		
Basic Size	mm	inches	um	inches	Fit	Shaft Dia.	Fit	Shaft Dia.
					.0004T	-.0000	.0011T	0.0007
04	20.000	0.7874	0	0.0000	.0005L	-.0005	.0003T	0.0003
05	25.000	0.9843	-10	-.0004	10T	0	27T	17
06	30.000	1.1811			13L	-13	8T	8
07	35.000	1.3780			.0005T	0.0000	.0013T	0.0008
08	40.000	1.5748	0	0.0000	.0006L	-.0006	.0004T	0.0004
09	45.000	1.7717	-12	-.0005	12T	0	33T	20
10	50.000	1.9685			16L	-16	9T	9
11	55.000	2.1654						
12	60.000	2.3622			.0006T	0.0000	.0016T	0.001
13	65.000	2.5591	0	0.0000	.0007L	0.0007	.0005T	0.0005
14	70.000	2.7559	-15	-.0006	15T	0	39T	24
15	75.000	2.9528			19L	-19	11T	11
16	80.000	3.1496						
17	85.000	3.3465						
18	90.000	3.5433			.0008T	-.0000	.0019T	0.0011
19	95.000	3.7402	0	0.0000	.0009L	-.0009	.0005T	0.0005
20	100.000	3.9370	-20	-.0008	20T	0	48T	28
21	105.000	4.1339			22L	-22	13T	13
22	110.000	4.3307						
24	120.000	4.7244						
26	130.000	5.1181						
28	140.000	5.5118			.0010T	-.0000	.0023T	0.0013
30	150.000	5.9055	0	0.0000	.0010L	-.0010	.0006T	0.0006
32	160.000	6.2992	-25	-.0010	25T	0	58T	33
34	170.000	6.6929			25L	-25	15T	13
36	180.000	7.0866						
					.0012T	0.000	.0026T	0.0014
38	190.000	7.4803	0	0.0000	.0012L	-.0012	.0006T	0.0006
40	200.000	7.8740	-30	-.0012	30T	0	67T	37
					29L	-29	17T	17

Class of Fit Selection

Operating conditions ■	Nominal shaft dia.		Class of fit	Remarks
	mm	inches		
Inner ring stationary in relation to direction of load	<i>All diameters</i>		h6	Tap fit inner ring
Inner ring rotating in relation to direction of load (Normal load $m=0.18C$)●	17-40	0.67-1.57	m5	Press fit inner ring
	40-65	1.57-2.56	m6	
	65-140	2.56-5.52	n6	
	140-200	5.52-7.88	p6	
Inner ring rotating in relation to direction of load (Heavy load $>.018C$)●	35-65	1.37-2.56	n6	Heavy press fit inner ring
	65-140	2.56-5.52	p6	
	140-200	5.52-7.88	r6	

Bearing/Shaft Diameter Fit

Bearing Series 1000, 1200, 1300, 1900, 5200, 5300, 7300	m6		n6		p6		r6		
	Tolerance		Tolerance		Tolerance		Tolerance		
	Basic size	Fit	Shaft dia.	Fit	Shaft dia.	Fit	Shaft dia.	Fit	Shaft dia.
04
05
06
07	.0015T	0.0010	.0018T	0.0013
thru	.0004T	0.0004	.0007T	0.0007
10	38T	25	46T	33
	9T	9	17T	17
11	.0018T	0.0012	.0021T	0.0015	.0027T	0.0021
thru	.0005T	0.0005	.0008T	0.0008	.0014T	0.0014
16	45T	30	54T	39	66T	51
	11T	11	20T	20	32T	32
17	.0022T	0.0014	.0027T	0.0019	.0033T	0.0025	.0037T	0.0029	0.0029
thru	.0005T	0.0005	.0010T	0.0010	.0016T	0.0016	.0020T	0.0020	0.0020
24	55T	35	65T	45	79T	59	96T	76	76
	13T	13	23T	23	37T	37	54T	54	54
26	.0026T	0.0016	.0032T	0.0022	.0038T	0.0028	.0045T	0.0035	0.0035
thru	.0006T	0.0006	.0012T	0.0012	.0018T	0.0018	.0025T	0.0025	0.0025
36	65T	40	77T	52	93T	68	118T	93	93
	15T	15	27T	27	43T	43	68T	68	68
	.0030T	0.0018	.0038T	0.0026	.0044T	0.0032	.0054T	0.0042	0.0042
38	.0006T	0.0006	.0014T	0.0014	.0020T	0.0020	.0030T	0.0030	0.0030
40	76T	46	90T	60	109T	79	136T	106	106
	17T	17	31T	31	50T	50	77T	77	77

▲ Symbol L indicates a loose or clearance fit. Symbol T indicates a tight or interference fit. The appropriate shaft diameter for any class of fit can be easily determined by applying the shaft tolerance to the nominal shaft diameter. Example: (Using basic bearing size 03 and fit class h6)

	inches		mm	
Nominal shaft diameter	= .6693	.6693	= 17.000	17.000
Shaft diameter tolerance	= +.0000	-.0004	= + 0.000	-0.010

Resultant shaft diameter = .6693 .6689 = 17.000 16.989

1 μ m = .001 mm

■ For solid steel shafts.

● C = Basic Load Rating of bearing.

▲ The arithmetical mean of the largest and smallest single diameter to be within tolerance shown. Allowable deviations from mean diameter per ANSI/ABMA STD 20, latest printing.

Housing Bearing Seat Diameters

Bearing outside diameter tolerances are in accordance with the system of tolerancing established by the International Standards Organization (ISO) and adopted by the American Bearing Manufacturers Association (ABMA) and the American National Standards Institute (ANSI).

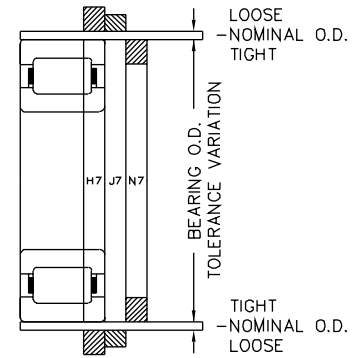
A system of limits and fits has been established by ISO for holes. A portion of this system has been adopted by ABMA to provide flexibility in selecting housing fits. Housing fits are designated by a capital letter and a number such as H7. The letter indicates the location of the housing bore tolerance limits with respect to the nominal bearing O.D. The number indicates the size of the tolerance zone.

Housing fits recommended for various types of applications are listed in the table at the right. A graphic relationship of various housing fits is illustrated in the figure at the left. The class of fit is determined by nature of loading (oscillating, vibrating, reversing, etc.), axial movement requirements, temperature conditions, housing material and cross section of housing.

Shaft expansion increases bearing center distances and requires all but one bearing on a shaft to be movable axially in the housing. In most bearings the outer rings are subjected to stationary loads which permit a loose housing fit.

Operating temperature may affect the housing fit, as the housing may dissipate heat rapidly and not expand with the outer ring. However, the loose fit must never be greater than necessary. Excessive looseness results in less accurate shaft centering and additional ring deformation under load.

The appropriate housing bores are determined (as shown) from the tables below.



Class of Fit and Housing Bores (inches/ μ m)

Bearing Series						Bearing/Housing Diameter Fits Δ						
1900	1000	1200	1300	Nominal Bearing O.D. And Housing Bore	Bearing O.D. Tolerance Δ	H7		J7		N7		
		5200	5300			7300	Tolerance		Tolerance		Tolerance	
Basic Size					mm	inches	Fit	Housing Bore	Fit	Housing Bore	Fit	Housing Bore
...	...	205	304	52	2.0472	0	0	0	.0004T	-0.0004	.0002L	-0.0003
...	...	206	305	62	2.4409	-.0005	.0017L	0.0012	.0013L	\neq .0008	.0015T	-0.0015
...	...	207	306	72	2.8346	0	0	0	12T	-12	4L	-9
911	010	208	307	80	3.1496	-13	43L	30	31L	-18	39T	-39
912	...	209	...	85	3.3465							
913	011	210	308	90	3.5433	0	0	0	.0005T	-0.0005	.0002L	-0.0004
...	012	95	3.7402							
914	013	211	309	100	3.9370	-.0006	.0020L	0.0014	.0015L	0.0009	.0018T	-0.0018
915	105	4.1339	0	0	0	13T	-13	5L	-10
916	014	212	310	110	4.3307	-15	50L	35	37L	22	45T	-45
...	015	115	4.5276							
917	...	213	311	120	4.7244							
918	016	214	...	125	4.9213	0	0	0	.0006T	-0.0006	.0002L	-0.0006
919	017	215	312	130	5.1181	-.0008	.0024L	0.0016	.0018L	0.0010	.0022T	-0.0002
920	018	216	313	140	5.5118	0	0	0	14T	-14	6L	-12
921	019	145	5.7087	-20	61L	41	44L	26	52T	-52
922	020	217	314	150	5.9055							
...	021	218	315	160	6.2992	0	0	0	.0006T	-0.0006	.0004L	-0.0006
924	165	6.4961	-.0010	.0026L	0.0016	.0020L	0.001	.0022T	-0.0022
...	022	219	316	170	6.6929	0	0	0	14T	-14	13L	-12
926	024	220	317	180	7.0866	-25	65L	40	51L	26	57T	-52
928	...	221	318	190	7.4803							
...	026	222	319	200	7.8740							
930	028	210	8.2677	0	0	0	.0007T	-0.0007	.0004L	-0.0008
...	...	224	320	215	8.4646	-0.0012	.0030L	0.0018	.0023L	0.0011	.0026T	-0.0026
932	321	220	8.6614	0	0	0	16T	-16	16L	-14
...	030	225	8.8583							
934	...	226	322	230	9.0551	-30	76L	46	60L	30	60T	-60
...	032	240	9.4488							
936	...	228	...	250	9.8425							
938	034	...	324	260	10.2362	0	0	0	.0007T	-0.0007	.0006L	-0.0008
...	...	230	...	270	10.6299	-.0014	.0034L	0.002	.0027L	0.0013	.0028T	-0.0028
940	036	...	326	280	11.0236	0	0	0	16T	-16	21L	-14
...	038	232	...	290	11.4173	-35	87L	52	71L	36	66T	-66
...	328	300	11.8110							
...	040	234	...	310	12.2047							
...	...	236	330	320	12.5984	-.0016	.0038L	0.0022	.0030L	0.0014	.0030T	-0.0008
...	...	238	...	340	13.3858	0	0	0	8T	-18	24L	-16
...	...	240	...	360	14.1732	-40	97L	57	79L	39	73T	-73

1 μ m = .001 mm

□ Minimum housing bore is same as ABMA fit class; tolerance is within ABMA range.

■ Style A outer ring has oversize O.D. designed to give a heavy press fit with a tap fit housing bore. Inner ring to be press fit for values.

Δ The arithmetical mean of the largest and smallest single diameter to be within tolerance shown.

Allowable deviations from mean diameter per ANSI/ABMA STD 20, latest printing.

Class of Fit Selection

Operating conditions	Class of fit	Remarks
Housing stationary in relation to direction of load	H7	Push fit outer ring for non-separable bearing styles MU...UV and MU...UM
Housing stationary in relation to direction of load	J7□	Tap fit outer ring
Housing rotating in relation to direction of load	N7□	Press fit outer ring
	■	Heavy press fit with Style A outer ring

Heavy Press Fit With Style A Outer Ring (inches/μm)

Bearing Series				Nominal Bearing O.D. And Housing Bore Style A Outer Ring		Bearing O.D. Tolerance Δ	Bearing/Housing Diameter Fits ▲			
1900	1000	1200 5200	1300 5300 7300	mm	inches		Tolerance			Housing Bore
Basic Size							Fit			
...	...	205	304	52.024	2.0482	0.0000	.00000	0	-.0005	-13
...	...	206	305	62.029	2.4421	-0.0005	.0014T	35T	-.0014	-35
...	...	207	306	72.032	2.8359	0	.0001T	2T	-.0006	-15
...	...	207	306	72.032	2.8359	-13	.0016T	40T	-.0016	-40
...	...	207	306	72.032	2.8359	0	.0002T	5T	-.0007	-18
911	010	208	307	80.035	3.151	0	.0017T	43T	-.0017	-43
...	...	208	307	80.035	3.151	0	.0003T	7T	-.0008	-20
...	...	208	307	80.035	3.151	0	.0018T	45T	-.0018	-45
912	...	209	...	85.039	3.348	0	.0004T	10T	-.0010	-25
...	...	209	...	85.039	3.348	0	.0020T	50T	-.0020	-50
913	011	210	308	90.04	3.5449	0	.0005T	13T	-.0011	-28
...	...	210	308	90.04	3.5449	0	.0021T	53T	-.0021	-53
...	012	95.044	3.7419	0.0000	.0006T	15T	-.0012	-30
...	...	210	308	90.04	3.5449	-0.0006	.0022T	56T	-.0022	-56
914	013	211	309	100.046	3.9388	0	.0007T	18T	-.0013	-33
...	...	211	309	100.046	3.9388	-15	.0023T	58T	-.0023	-58
915	105.049	4.1358	0	.0008T	20T	-.0014	-35
...	...	211	309	100.046	3.9388	0	.0024T	61T	-.0024	-61
916	014	212	310	110.056	4.3329	0	.0009T	23T	-.0017	-38
...	015	115.057	4.5298	0	.0027T	69T	-.0027	-69
917	...	213	311	120.056	4.7266	0	.0009T	23T	-.0017	-43
918	016	214	...	125.059	4.9236	0.0000	.0029T	74T	-.0029	-74
919	017	215	312	130.058	5.1204	-0.0008	.0010T	25T	-.0018	-45
920	018	216	313	140.058	5.5141	0	.0032T	81T	-.0032	-81
921	019	145.067	5.7113	-20	.0010T	25T	-.0020	-50
922	020	217	314	150.066	5.9081	0	.0034T	86T	-.0034	-86
...	021	218	315	160.071	6.302	0.0000	.0010T	25T	-.0020	-50
924	165.072	6.4989	-0.0010	.0012T	30T	-.0024	-60
...	022	219	316	170.071	6.6957	0	.0038T	97T	-.0038	-97
926	024	220	317	180.071	7.0894	-25	.0013T	33T	-.0025	-63
928	...	221	318	190.076	7.4833	0	.0039T	99T	-.0039	-99
...	026	222	319	200.078	7.8771	-0.0012	.0013T	33T	-.0025	-63
930	028	210.081	8.2709	0	.0039T	99T	-.0039	-99
...	...	224	320	215.087	8.468	0	.0013T	33T	-.0025	-63
932	220.088	8.6649	0	.0041T	104T	-.0041	-104
...	030	...	321	225.09	8.8618	0	.0014T	36T	-.0026	-66
934	...	226	...	230.091	9.0587	-30	.0042T	107T	-.0042	-107
...	032	...	322	240.096	9.4526	0	.0015T	38T	-.0027	-68
936	...	228	...	250.096	9.8463	0	.0043T	109T	-.0043	-109
...	...	228	...	250.096	9.8463	0	.0015T	38T	-.0027	-68
...	...	228	...	250.096	9.8463	0	.0045T	114T	-.0045	-114
938	034	...	324	260.101	10.2402	0.0000	.0015T	38T	-.0029	-73
...	...	230	...	270.101	10.6339	-0.0014	.0047T	119T	-.0047	-119
940	036	...	326	280.101	11.0276	0	.0016T	41T	-.0030	-76
...	038	232	...	290.109	11.4216	-35	.0050T	127T	-.0050	-127
...	328	300.111	11.8154	0	.0017T	43T	-.0031	-78
...	040	234	...	310.111	12.2091	0	.0051T	130T	-.0051	-130
...	...	236	330	320.121	12.6032	0.0000	.0017T	43T	-.0033	-83
...	...	238	...	340.121	13.3906	-0.0016	.0055T	140T	-.0055	-140
...	...	240	...	360.124	14.1781	0	.0018T	46T	-.0043	-86
...	...	240	...	360.124	14.1781	-40	.0056T	142T	-.0056	-142

▲ Symbol L indicates a loose or clearance fit. Symbol T indicates a tight or interference fit. The appropriate housing bore for any class of fit can be easily determined by applying the housing tolerance to the nominal housing bore. Example: (Using basic bearing size 926 and fit class N7)

Nominal housing bore	inches = 7.0866	mm = 180.000
Housing bore tolerance	= -.0006 - .0022	= -.012 - .052
Resultant housing bore	= 7.0860	= 179.988

Operation Without Inner Ring/Outer Ring

Outer Ring and Roller Assembly

for Series M-EX, M-EAX, M-EB, M-EAB, M-TV, M-TAV, M-UV and M-UAV

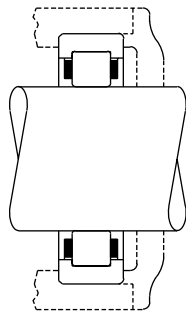
Cylindrical roller bearings with the inner ring omitted may be installed so that the rollers operate directly on the surface of the shaft.

This type of design is useful for applications where space is limited or a larger shaft is required. Surface hardness of shaft must be Rockwell C59 to C64 to achieve full bearing capacity. Where the required hardness cannot be attained, the bearing rating must be reduced accordingly. Where the shaft is case hardened, the combination of case depth and core hardness must be adequate. Consult Rexnord Bearing Division for a specific recommendation. Shaft surface should be finished to a roughness value of 13 micro-inches, RMS, maximum (.33 μm).

Maximum and minimum shaft diameter values for tap fit and press fit outer rings are listed below.

Hardness Factor

If operation at rated capacity is desired when cylindrical roller bearings are used with either ring omitted, the surface on which the rollers operate must have a hardness of Rockwell C59 to C64 or equivalent Brinell hardness (see chart below). If this hardness cannot be attained, the bearing C capacity must be reduced by a rating reduction factor determined from chart on facing page.



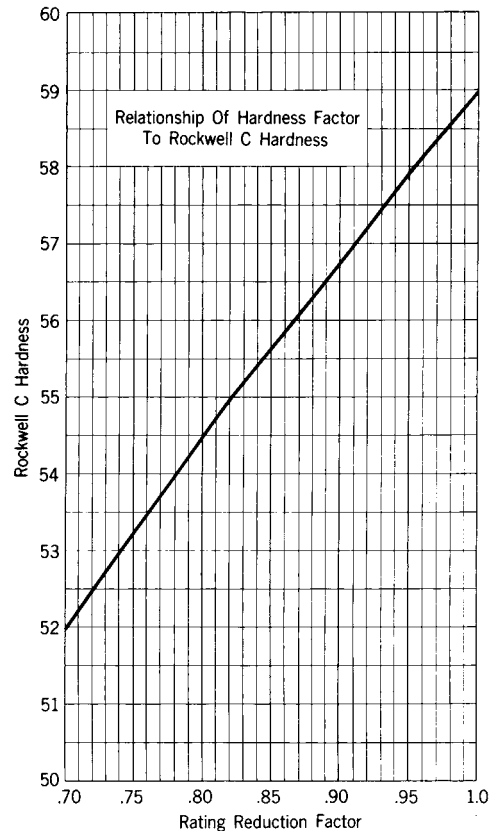
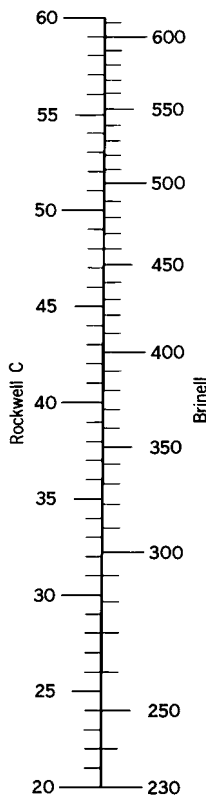
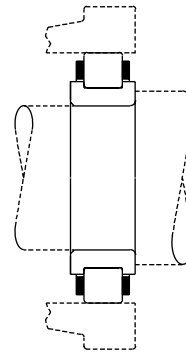
Inner Ring and Roller Assembly

for Series MU-X, MU-B

Cylindrical roller bearings with the outer ring omitted may be installed so that the rollers operate directly on the hardened and ground surface of a bore in an alloy steel housing.

This type of design is useful for applications where space is limited and a smaller housing bore or a larger bearing and shaft are required. Housing surface hardness must be Rockwell C59 to C64 or Brinell equivalent to achieve full bearing capacity. Where the required hardness cannot be attained, the bearing rating must be reduced accordingly. See graph for rating reduction factor. Where the housing bore is case hardened, the combination of case depth and core hardness must be adequate. Consult Rexnord Bearing Division for a specific recommendation. Housing surface should be finished to a roughness value of 13 micro-inches, A.A., maximum (.33 μm).

Maximum and minimum housing bore values for tap fit and press fit inner rings are listed on the next page.



Shaft Diameters for Outer Ring

Shaft Diameter for Tap Fit Outer Ring ▲									Shaft Diameter for Press Fit Outer Ring							
Bearing series	1900		1000		1200-5200		1300-5300-7300		1900	1000		1200-5200		1300-5300-7300		
Basic size	(max-min)								inches							
									(max-min)							
03	0.8757	0.8753	0.8725	0.8721	0.9803	0.9799	0.8750	0.8746	0.8718	0.8714	0.9796	0.9792
04	0.9769	0.9765	1.0329	1.0325	1.1092	1.1087	1.1013	1.1008	0.9762	0.9758	1.0322	1.0318	1.1085	1.1080	1.1005	1.1000
05	1.1759	1.1754	1.2259	1.2254	1.2672	1.2667	1.3383	1.3378	1.1753	1.1748	1.2253	1.2248	1.2665	1.2660	1.3376	1.3371
06	1.3710	1.3705	1.4523	1.4518	1.4994	1.4989	1.6024	1.6019	1.3704	1.3699	1.4515	1.4510	1.4986	1.4981	1.6016	1.6011
07	1.6112	1.6107	1.6611	1.6606	1.7322	1.7317	1.8452	1.8447	1.6104	1.6099	1.6603	1.6598	1.7314	1.7309	1.8444	1.8439
08	1.8061	1.8056	1.8777	1.8772	1.9667	1.9662	2.0600	2.0595	1.8054	1.8049	1.8770	1.8765	1.9660	1.9655	2.0590	2.0585
09	2.0263	2.0258	2.0831	2.0825	2.1870	2.1864	2.3382	2.3376	2.0255	2.0250	2.0823	2.0817	2.1861	2.1855	2.3373	2.3367
10	2.2014	2.2008	2.2802	2.2796	2.3816	2.3810	2.5660	2.5654	2.2006	2.2000	2.2794	2.2788	2.3807	2.3801	2.5651	2.5645
11	2.4316	2.4310	2.5408	2.5402	2.6354	2.6348	2.8136	2.8130	2.4308	2.4302	2.5398	2.5392	2.6344	2.6338	2.8127	2.8121
12	2.6316	2.6310	2.7377	2.7371	2.8511	2.8505	3.0545	3.0538	2.6307	2.6301	2.7368	2.7362	2.8502	2.8496	3.0534	3.0527
13	2.8267	2.8261	2.9348	2.9341	3.1677	3.1670	3.2957	3.2950	2.8258	2.8252	2.9339	2.9332	3.1668	3.1661	3.2946	3.2939
14	3.0719	3.0712	3.1588	3.1581	3.3392	3.3385	3.5132	3.5125	3.0710	3.0703	3.1579	3.1572	3.3381	3.3374	3.5120	3.5113
15	3.2669	3.2662	3.3569	3.3562	3.5063	3.5056	3.7780	3.7772	3.2660	3.2653	3.3560	3.3553	3.5052	3.5045	3.7769	3.7761
16	3.4619	3.4612	3.5969	3.5962	3.7532	3.7525	4.0031	4.0023	3.4610	3.4603	3.5958	3.5951	3.7520	3.7513	4.0020	4.0012
17	3.7274	3.7267	3.7944	3.7936	4.0182	4.0174	4.2746	4.2738	3.7265	3.7258	3.7933	3.7925	4.0171	4.0163	4.2735	4.2727
18	3.9225	3.9217	4.0324	4.0316	4.2235	4.2227	4.4915	4.4907	3.9214	3.9206	4.0313	4.0305	4.2224	4.2216	4.4902	4.4894
19	4.1174	4.1166	4.2284	4.2276	4.4714	4.4706	4.8113	4.8105	4.1163	4.1155	4.2273	4.2265	4.4703	4.4695	4.8099	4.8091
20	4.3330	4.3322	4.4254	4.4246	4.7663	4.7655	5.1267	5.1258	4.3319	4.3311	4.4243	4.4235	4.7652	4.7644	5.1254	5.1245

Housing Bore for Outer Ring

Housing Bore for Tap Fit Inner Ring									Housing Bore for Press Fit Inner Ring							
Bearing series	1900		1000		1200-5200		1300-5300-7300		1900	1000		1200-5200		1300-5300-7300		
Basic size	(max-min)								inches							
									(max-min)							
03	1.1992	1.1988	1.3708	1.3704	1.5402	1.5398	1.1996	1.1992	1.3712	1.3708	1.5406	1.5402
04	1.2689	1.2685	1.4383	1.4379	1.6075	1.6070	1.7305	1.7300	1.2694	1.2690	1.4388	1.4384	1.6080	1.6075	1.7309	1.7304
05	1.4680	1.4675	1.6314	1.6309	1.7656	1.7651	2.1031	2.1026	1.4686	1.4681	1.6320	1.6315	1.7661	1.7656	2.1036	2.1031
06	1.6631	1.6626	2.9090	1.9085	2.1285	2.1280	2.3780	2.3775	1.6637	1.6632	1.9096	1.9091	2.1291	2.1286	2.3785	2.3780
07	1.9346	1.9341	2.1594	2.1589	2.4591	2.4586	2.6745	2.6740	1.9353	1.9348	2.1600	2.1595	2.4597	2.4592	2.6751	2.6746
08	2.2116	2.2111	2.3760	2.3755	2.7405	2.7400	3.0572	3.0567	2.2123	2.2118	2.3767	2.3762	2.7411	2.7406	3.0578	3.0573
09	2.4317	2.4312	2.6430	2.6424	2.9517	2.9511	3.3894	3.3888	2.4325	2.4320	2.6438	2.6432	2.9526	2.9520	3.3902	3.3896
10	2.6068	2.6062	2.8400	2.8394	3.1311	3.1305	3.7195	3.7189	2.6077	2.6071	2.8409	2.8403	3.1319	3.1313	3.7203	3.7197
11	2.8881	2.8875	3.1697	3.1691	3.4646	3.4640	4.0784	4.0778	2.8892	2.8886	3.1707	3.1701	3.4656	3.4650	4.0793	4.0787
12	3.0882	3.0876	3.3668	3.3662	3.8481	3.8475	4.4280	4.4273	3.0893	3.0887	3.3678	3.3672	3.8491	3.8485	4.4289	4.4282
13	3.2832	3.2826	3.5639	3.5632	4.1649	4.1642	4.7775	4.7768	3.2843	3.2837	3.5649	3.5642	4.1658	4.1651	4.7758	4.7751
14	3.6316	3.6309	3.9323	3.9316	4.3902	4.3895	5.0926	5.0919	3.6329	3.6322	3.9337	3.9330	4.3915	4.3908	5.0938	5.0931
15	3.8266	3.8259	4.1304	4.1297	4.5573	4.5566	5.4770	5.4762	3.8280	3.8273	4.1317	4.1310	4.5585	4.5578	5.4782	5.4774
16	4.0217	4.0210	Δ	Δ	4.9068	4.9061	5.8033	5.8025	4.0230	4.0223	Δ	Δ	4.9081	4.9074	5.8045	5.8037
17	4.3561	4.3554	4.6515	4.6507	5.2829	5.2821	6.1966	6.1958	4.3578	4.3571	4.6772	4.6764	5.2845	5.2837	6.1981	6.1973
18	4.5512	4.5504	5.0292	5.0284	5.5968	5.5960	6.5109	6.5101	4.5529	4.5521	5.0309	5.0301	5.5984	5.5976	6.5124	6.5116
19	4.7463	4.7455	5.2253	5.2245	5.9532	5.9524	6.8308	6.8300	4.7480	4.7472	5.2269	5.2261	5.9548	5.9540	6.8322	6.8314
20	5.1064	5.1056	Δ	Δ	6.3459	6.3451	7.2787	7.2778	5.1082	5.1074	Δ	Δ	6.3474	6.3466	7.2802	7.2793

For shaft diameters larger than above, consult Rexnord Bearing Division.

Δ For size, consult Rexnord Bearing Division.

▲ Shaft diameter limits also apply to Style A outer ring bearings.

■ Hultgren 10 mm ball penetrator; 3000 kg load.

□ Brale penetrator; 150 kg load.

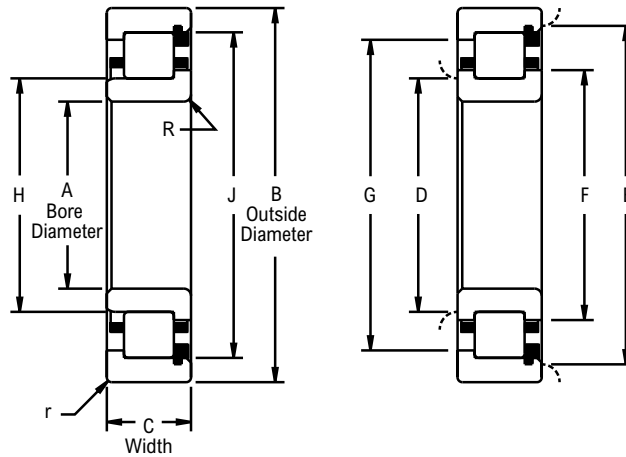
25 mm, 30 mm, 35 mm, 40 mm Bores



Photo Shows an Unmounted Cylindrical Roller Bearing Assembly

Product Features

- Fully crowned rollers
- Precision ground ribs
- Contoured roller pockets
- Rollers individually separated
- Optional full complement
- See Features and Benefits for additional info on page 472.



Bearing Dimensions

Basic Bearing Number	A Bore Diameter		B Outside Diameter		C Bearing Width		D		E		F	G	H	J	R	r
	mm	in	mm	in	mm	in	Plain	Ribbed	Plain	Ribbed						
1205	25.0000	0.9843	52.0000	2.0472	15.0000	0.5906	30.50	32.00	47.00	44.70	34.32	42.95	32.166	44.854	1.02	1.02
5205					20.6380	0.8125										
1305					17.0000	0.6693										
7305					21.0000	0.8268										
5305					25.4000	1.0000										
1206	30.0000	1.1811	62.0000	2.4409	16.0000	0.6299	36.10	37.80	56.40	53.80	40.87	51.48	38.062	54.074	1.02	1.02
5206					23.8120	0.9375										
1306					19.0000	0.7480										
7306					23.0000	0.9055										
5306					30.1620	1.1875										
1207	35.0000	1.3780	72.0000	2.8346	17.0000	0.6693	41.60	43.90	65.30	62.20	47.29	59.51	43.970	62.471	1.02	1.02
5207					26.9980	1.0629										
1307					21.0000	0.8268										
7307					26.0000	1.0236										
5307					34.9250	1.3750										
1208	40.0000	1.5748	80.0000	3.1496	18.0000	0.7087	47.20	49.80	72.90	69.60	53.44	66.42	49.929	69.619	1.52	1.02
5208					30.1620	1.1875										
1308					23.0000	0.9055										
7308					30.0000	1.1811										
5308					36.5120	1.4375										

Additional Notes

- Please call 1-866-REXNORD for availability
- Dimensions "R" & "r", largest fillet radius that will clear bearing corners
- For the Selection Guide, Load Ratings and Speed Limits, see the Link-Belt Cylindrical Roller Bearing Engineering section on pages 474 - 489.
- For shaft and housing bearing seat diameters, see Link-Belt Cylindrical Roller Bearing Shaft & Housing Seat Diameters section on pages 484 - 487.
- Note: Dimensions subject to change. Certified dimensions of ordered material furnished on request.

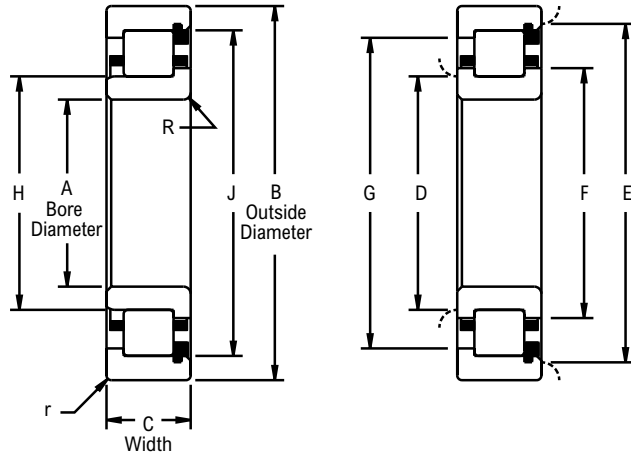
45 mm, 50 mm, 55 mm Bores



Photo Shows an Unmounted Cylindrical Roller Bearing Assembly

Product Features

- Fully crowned rollers
- Precision ground ribs
- Contoured roller pockets
- Rollers individually separated
- Optional full complement
- See Features and Benefits for additional info on page 472.



Bearing Dimensions

Basic Bearing Number	A Bore Diameter		B Outside Diameter		C Bearing Width		D		E		F	G	H	J	R	r										
	mm	in	mm	in	mm	in	Plain	Ribbed	Plain	Ribbed																
1209	45.0000	1.7717	85.0000	3.3465	19.0000	0.7480	52.80	55.40	78.20	74.90	59.03	71.80	55.519	74.988	1.52	1.02										
5209					30.1620	1.1875																				
1309					25.0000	0.9843																				
7309					31.0000	1.2205																				
5309					39.6880	1.5625																				
1010	50.0000	1.9685	80.0000	3.1496	16.0000	0.6299	56.10	57.60	74.40	72.10	60.43	69.62	57.882	72.151	1.52	1.02										
1210					20.0000	0.7874																				
5210					30.1620	1.1875																				
1310					27.0000	1.0630																				
7310					33.0000	1.2992																				
5310	44.4500	1.7500																								
1911	55.0000	2.1654	80.0000	3.1496	13.0000	0.5118	59.90	61.70	75.20	73.20	64.26	70.84	61.722	73.378	1.02	1.02										
1011					18.0000	0.7087																				
1211					21.0000	0.8268																				
5211					33.3380	1.3125																				
1311					29.0000	1.1417																				
7311					36.0000	1.4173																				
5311					49.2120	1.9375											66.50	71.40	108.70	103.40	77.34	98.04	71.432	103.607	2.03	2.03

Additional Notes

- Please call 1-866-REXNORD for availability
- Dimensions "R" & "r", largest fillet radius that will clear bearing corners
- For the Selection Guide, Load Ratings and Speed Limits, see the Link-Belt Cylindrical Roller Bearing Engineering section on pages 474 - 489.
- For shaft and housing bearing seat diameters, see Link-Belt Cylindrical Roller Bearing Shaft & Housing Seat Diameters section on pages 484 - 487.
- Note: Dimensions subject to change. Certified dimensions of ordered material furnished on request.

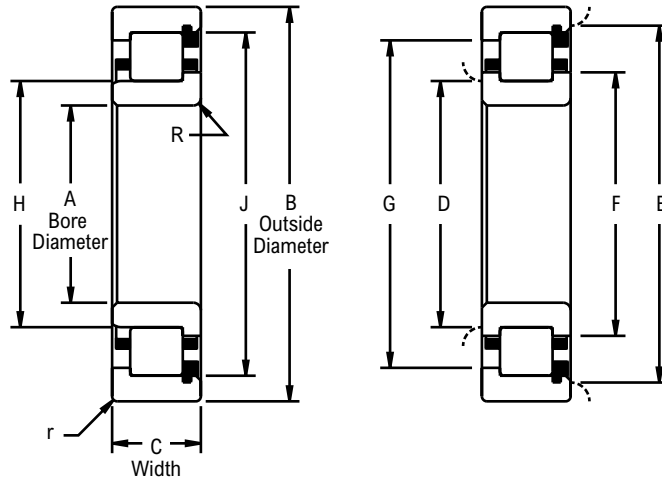
60 mm, 65 mm, 70 mm Bores



Photo Shows an Unmounted Cylindrical Roller Bearing Assembly

Product Features

- Fully crowned rollers
- Precision ground ribs
- Contoured roller pockets
- Rollers individually separated
- Optional full complement
- See Features and Benefits for additional info on page 472.



Bearing Dimensions

Basic Bearing Number	A Bore Diameter		B Outside Diameter		C Bearing Width		D		E		F	G	H	J	R	r	
	mm	in	mm	in	mm	in	Plain	Ribbed	Plain	Ribbed							
1912	60.0000	2.3622	85.0000	3.3465	13.0000	0.5118	65.00	66.80	80.30	78.20	69.34	75.92	66.802	78.461	1.02	1.02	
1012			95.0000	3.7402	18.0000	0.7087	67.00	69.30	88.60	85.30	72.69	82.35	69.499	85.534	1.52		
1212			110.0000	4.3307	22.0000	0.8661	69.30	72.10	101.30	97.50	76.94	93.50	72.380	97.762	2.03		1.52
5212			36.5120	1.4375													
1312			130.0000	5.1181	31.0000	1.2205	72.90	77.50	117.80	112.30	84.02	106.35	77.551	112.486	2.54		2.03
7312					38.0000	1.4961											
5312	53.9750	2.1250															
1913	65.0000	2.5591	90.0000	3.5433	13.0000	0.5118	70.10	71.60	85.30	83.30	74.30	80.87	71.755	83.416	1.02	1.02	
1013			100.0000	3.9370	18.0000	0.7087	72.10	74.40	93.70	90.40	77.72	87.35	74.503	90.541	1.52		
1213			120.0000	4.7244	23.0000	0.9055	77.00	80.30	110.00	105.70	85.34	101.24	80.421	105.804	2.54		1.52
5213			38.1000	1.5000													
1313			140.0000	5.5118	33.0000	1.2992	78.70	83.60	127.00	121.20	90.70	114.68	83.675	121.366	2.03		
7313					40.0000	1.5748											
5313	58.7380	2.3125															
1914	70.0000	2.7559	100.0000	3.9370	16.0000	0.6299	75.90	78.00	94.50	92.20	80.82	89.41	77.978	92.268	1.02	1.02	
1014			110.0000	4.3307	20.0000	0.7874	77.50	80.00	103.40	99.80	84.12	95.99	80.188	99.906	2.03		
1214			125.0000	4.9213	24.0000	0.9449	81.80	84.60	115.60	111.50	89.61	107.01	84.772	111.536	2.54		1.52
5214			39.6880	1.5625													
1314			150.0000	5.9055	35.0000	1.3780	84.30	89.20	135.60	129.30	96.72	122.20	89.192	129.375	3.18		2.03
7314					43.0000	1.6929											
5314	63.6000	2.5039															

Additional Notes

- Please call 1-866-REXNORD for availability
- Dimensions "R" & "r", largest fillet radius that will clear bearing corners
- For the Selection Guide, Load Ratings and Speed Limits, see the Link-Belt Cylindrical Roller Bearing Engineering section on pages 474 - 489.
- For shaft and housing bearing seat diameters, see Link-Belt Cylindrical Roller Bearing Shaft & Housing Seat Diameters section on pages 484 - 487.
- Note: Dimensions subject to change. Certified dimensions of ordered material furnished on request.

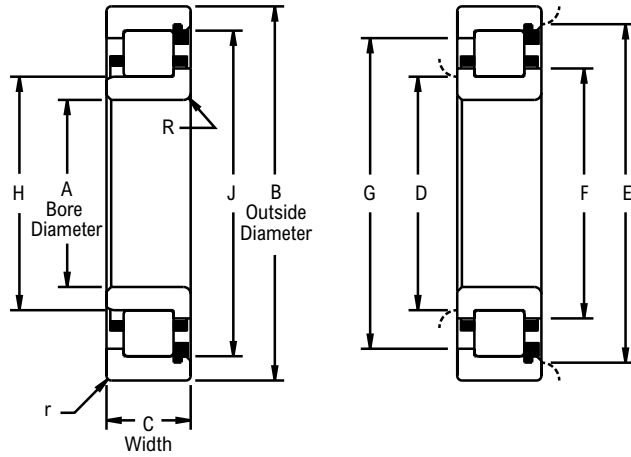
75 mm, 80 mm, 85 mm Bores



Photo Shows an Unmounted Cylindrical Roller Bearing Assembly

Product Features

- Fully crowned rollers
- Precision ground ribs
- Contoured roller pockets
- Rollers individually separated
- Optional full complement
- See Features and Benefits for additional info on page 472.



Bearing Dimensions

Basic Bearing Number	A Bore Diameter		B Outside Diameter		C Bearing Width		D		E		F	G	H	J	R	r	
	mm	in	mm	in	mm	in	Plain	Ribbed	Plain	Ribbed							
1915	75.0000	2.9528	105.0000	4.1339	16.0000	0.6299	80.80	82.80	99.60	97.00	85.78	94.39	82.931	97.221	1.02	1.02	
1015			115.0000	4.5276	20.0000	0.7874	82.60	85.10	108.40	104.90	89.15	101.02	85.217	104.938	2.03		
1215			130.0000	5.1181	25.0000	0.9843	85.60	88.90	120.10	115.60	93.85	111.25	89.014	115.781	2.54		1.52
5215			41.2750	1.6250													
1315			160.0000	6.2992	37.0000	1.4567	90.40	95.80	145.80	138.90	104.04	131.37	95.920	139.136	3.18		2.03
7315					46.0000	1.8110											
5315					68.2620	2.6875											
1916	80.0000	3.1496	110.0000	4.3307	16.0000	0.6299	85.80	87.90	104.40	102.10	90.73	99.34	87.884	102.176	1.02	1.02	
1016			125.0000	4.9213	22.0000	0.8661	88.40	91.20	117.60	113.50	95.71	109.45	91.313	113.088	2.03		
1216			140.0000	5.5118	26.0000	1.0236	91.20	95.20	129.30	124.50	100.79	119.38	95.286	124.658	2.54		
5216			44.4500	1.7500													
1316			170.0000	6.6929	39.0000	1.5354	96.00	101.60	154.40	147.30	110.29	139.19	101.636	147.424	3.18		2.03
7316					49.0000	1.9291											
5316					68.2620	2.6875											
1917	85.0000	3.3465	120.0000	4.7244	18.0000	0.7087	92.20	94.50	113.80	101.50	97.82	107.47	94.615	110.678	1.52	1.02	
1017			130.0000	5.1181	22.0000	0.8661	93.50	96.30	122.70	118.60	100.63	114.48	96.317	118.173	2.03		
1217			150.0000	5.9055	28.0000	1.1024	98.00	101.80	139.20	134.10	108.05	128.42	102.006	134.216	3.18		2.03
5217			49.2120	1.9375													
1317			180.0000	7.0866	41.0000	1.6142	102.90	108.40	164.30	157.20	118.24	148.64	108.522	157.422	3.96		2.54
7317					51.0000	2.0079											
5317					73.0250	2.8750											

Additional Notes

- Please call 1-866-REXNORD for availability
- Dimensions "R" & "r", largest fillet radius that will clear bearing corners
- For the Selection Guide, Load Ratings and Speed Limits, see the Link-Belt Cylindrical Roller Bearing Engineering section on pages 474 - 489.
- For shaft and housing bearing seat diameters, see Link-Belt Cylindrical Roller Bearing Shaft & Housing Seat Diameters section on pages 484 - 487.
- Note: Dimensions subject to change. Certified dimensions of ordered material furnished on request.

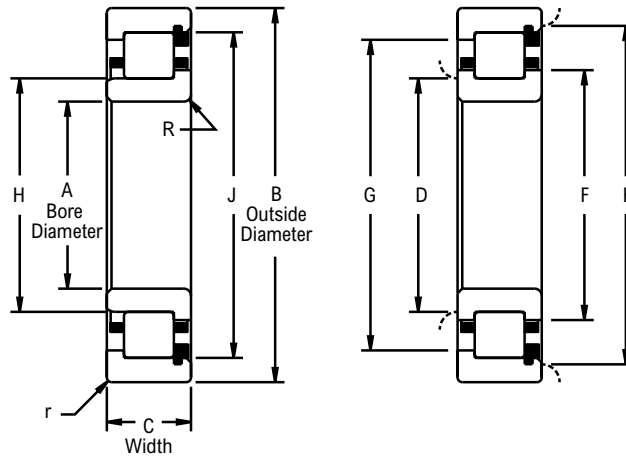
90 mm, 95 mm, 100 mm Bores



Photo Shows an Unmounted Cylindrical Roller Bearing Assembly

Product Features

- Fully crowned rollers
- Precision ground ribs
- Contoured roller pockets
- Rollers individually separated
- Optional full complement
- See Features and Benefits for additional info on page 472.



Bearing Dimensions

Basic Bearing Number	A Bore Diameter		B Outside Diameter		C Bearing Width		D		E		F	G	H	J	R	r		
	mm	in	mm	in	mm	in	Plain	Ribbed	Plain	Ribbed								
1918	90.0000	3.5433	125.0000	4.9213	18.0000	0.7087	97.00	99.60	118.60	115.60	102.77	112.92	99.568	115.636	1.52	1.02		
1018			140.0000	5.5118	24.0000	0.9449	99.60	102.40	131.60	127.80	107.42	122.71	102.362	127.775	2.54	1.52		
1218			160.0000	6.2992	30.0000	1.1811	52.3880	2.0625	103.10	107.20	147.60	142.00	114.17	135.89	107.218	142.189	3.18	2.03
5218			1318	43.0000	1.6929													
7318			190.0000	7.4803	54.0000	2.1260	73.0250	2.8750	108.20	113.80	172.70	165.40	124.33	156.16	114.031	165.047	3.96	2.54
5318			1919	130.0000	5.1181	18.0000												
1019			95.0000	3.7402	145.0000	5.7087	24.0000	0.9449	104.40	107.20	136.60	132.60	112.40	127.68	107.340	132.756	2.54	1.52
1219	170.0000	6.6929			32.0000	1.2598	55.5620	2.1875	109.00	113.30	157.00	151.10	121.03	144.48	113.518	151.242	3.18	2.03
5219	1319	45.0000			1.7717													
7319	200.0000	7.8740			56.0000	2.2047	77.7780	3.0621	115.10	121.90	181.90	173.50	132.46	164.29	122.154	173.530	3.96	2.54
5319	1920	140.0000			5.5118	20.0000												
1020	100.0000	3.9370			150.0000	5.9055	24.0000	0.9449	109.50	112.30	141.70	137.70	117.52	132.59	112.344	137.759	2.54	1.52
1220			180.0000	7.0866	34.0000	1.3386	60.3250	2.3750	116.10	120.90	167.10	161.00	128.45	154.18	121.006	161.216	3.96	2.03
5220			1320	47.0000	1.8504													
7320			215.0000	8.4646	60.0000	2.3622	82.5500	3.2500	122.40	130.00	194.60	184.60	140.46	175.06	130.165	184.907	4.75	2.54
5320																		

Additional Notes

- Please call 1-866-REXNORD for availability
- Dimensions "R" & "r", largest fillet radius that will clear bearing corners
- For the Selection Guide, Load Ratings and Speed Limits, see the Link-Belt Cylindrical Roller Bearing Engineering section on pages 474 - 489.
- For shaft and housing bearing seat diameters, see Link-Belt Cylindrical Roller Bearing Shaft & Housing Seat Diameters section on pages 484 - 487.
- Note: Dimensions subject to change. Certified dimensions of ordered material furnished on request.

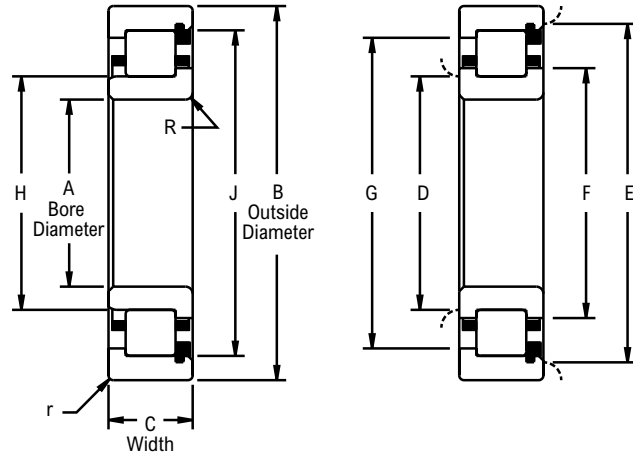
105 mm, 110 mm, 120 mm Bores



Photo Shows an Unmounted Cylindrical Roller Bearing Assembly

Product Features

- Fully crowned rollers
- Precision ground ribs
- Contoured roller pockets
- Rollers individually separated
- Optional full complement
- See Features and Benefits for additional info on page 472.



Bearing Dimensions

Basic Bearing Number	A Bore Diameter		B Outside Diameter		C Bearing Width		D		E		F	G	H	J	R	r
	mm	in	mm	in	mm	in	Plain	Ribbed	Plain	Ribbed						
1921	105.0000	4.1339	145.0000	5.7087	20.0000	0.7874	112.00	114.80	138.20	134.60	118.92	130.81	114.996	134.739	1.52	1.02
1021			160.0000	6.2992	26.0000	1.0236	115.80	119.10	150.10	145.80	124.48	140.61	119.151	145.941	2.54	2.03
1221			190.0000	7.4803	36.0000	1.4173	121.40	126.50	175.30	168.40	134.87	161.01	126.520	168.562	3.96	
5221			65.0880	2.5625	49.0000	1.9291										
1321			225.0000	8.8583	63.0000	2.4803	128.00	136.10	203.40	193.30	147.17	183.16	136.185	193.456	4.75	
7321			87.3120	3.4375												
5321																
1922	110.0000	4.3307	150.0000	5.9055	20.0000	0.7874	117.10	119.90	143.20	139.70	123.93	135.81	119.995	139.741	1.52	1.02
1022			170.0000	6.6929	28.0000	1.1024	121.90	125.20	159.20	154.70	131.09	149.00	125.349	154.744	2.54	2.03
1222			200.0000	7.8740	38.0000	1.4961	127.20	132.80	183.90	176.00	141.60	168.43	132.951	176.192	3.96	
5222			69.8500	2.7500	50.0000	1.9685										
1322			240.0000	9.4488	65.0000	2.5591	135.90	145.00	217.20	206.20	157.48	195.38	145.255	206.337	4.75	
7322			92.0750	3.6250												
5322																
1924	120.0000	4.7244	165.0000	6.4961	22.0000	0.8661	129.80	131.30	157.70	153.90	135.97	149.50	131.498	153.985	2.03	1.02
1024			180.0000	7.0866	28.0000	1.1024	132.10	135.10	169.20	164.60	141.22	158.90	135.357	164.754	3.18	2.03
1224			215.0000	8.4646	40.0000	1.5748	139.20	145.00	198.90	190.80	154.30	182.73	145.138	190.952	4.75	
5224			76.2000	3.0000	55.0000	2.1654										
1324			260.0000	10.2362	71.0000	2.7953	147.80	157.00	223.00	223.00	170.18	211.20	157.023	223.053	6.35	
7324			104.7750	4.1250												
5324																

Additional Notes

- Please call 1-866-REXNORD for availability
- Dimensions "R" & "r", largest fillet radius that will clear bearing corners
- For the Selection Guide, Load Ratings and Speed Limits, see the Link-Belt Cylindrical Roller Bearing Engineering section on pages 474 - 489.
- For shaft and housing bearing seat diameters, see Link-Belt Cylindrical Roller Bearing Shaft & Housing Seat Diameters section on pages 484 - 487.
- Note: Dimensions subject to change. Certified dimensions of ordered material furnished on request.

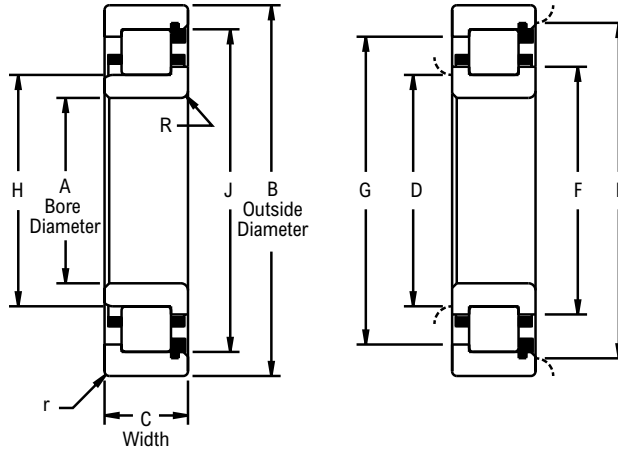
130 mm, 140 mm, 150 mm Bores



Photo Shows an Unmounted Cylindrical Roller Bearing Assembly

Product Features

- Fully crowned rollers
- Precision ground ribs
- Contoured roller pockets
- Rollers individually separated
- Optional full complement
- See Features and Benefits for additional info on page 472.



Bearing Dimensions

Basic Bearing Number	A Bore Diameter		B Outside Diameter		C Bearing Width		D		E		F	G	H	J	R	r
	mm	in	mm	in	mm	in	Plain	Ribbed	Plain	Ribbed						
1926	130.0000	5.1181	180.0000	7.0866	24.0000	0.9449	139.20	142.20	171.70	167.60	147.42	162.99	142.367	167.085	2.03	1.52
1026			200.0000	7.8740	33.0000	1.2992	143.00	147.60	188.20	182.40	154.56	175.59	147.574	182.570	3.18	2.03
1226			230.0000	9.0551	40.0000	1.5748	149.10	154.90	213.90	206.20	164.72	197.13	154.973	206.375	4.75	2.54
5226			79.3750	3.1250												
1326			280.0000	11.0236	58.0000	2.2835	160.30	170.40	254.50	242.60	184.91	229.77	170.536	242.755	6.35	3.18
7326					75.0000	2.9528										
5326					111.1250	4.3750										
1928	190.0000	7.4803			24.0000	0.9449										
1028	140.0000	5.5118	210.0000	8.2677	33.0000	1.2992	153.70	157.50	198.10	192.50	164.54	185.60	157.556	192.557	3.96	2.03
1228			250.0000	9.8425	42.0000	1.6535	161.50	168.40	232.40	224.30	179.07	214.38	168.460	224.417	4.75	2.54
5228			82.5500	3.2500												
1328			300.0000	11.8110	62.0000	2.4409	172.00	181.60	271.30	258.10	196.98	244.35	181.684	258.082	7.92	3.18
7328					83.0000	3.2677										
5328					114.3000	4.5000										
1930	150.0000	5.9055	210.0000	8.2677	28.0000	1.1024	161.50	165.40	199.10	194.60	171.22	188.92	165.354	194.790	3.18	2.03
1030			225.0000	8.8583	35.0000	1.3780	164.30	168.60	212.30	206.20	176.20	198.93	168.681	206.454	3.96	
1230			270.0000	10.6299	45.0000	1.7717	174.20	181.40	251.00	241.80	193.04	231.01	181.544	241.854	6.35	2.54
5230			88.9000	3.5000												

Additional Notes

- Please call 1-866-REXNORD for availability
- Dimensions "R" & "r", largest fillet radius that will clear bearing corners
- For the Selection Guide, Load Ratings and Speed Limits, see the Link-Belt Cylindrical Roller Bearing Engineering section on pages 474 - 489.
- For shaft and housing bearing seat diameters, see Link-Belt Cylindrical Roller Bearing Shaft & Housing Seat Diameters section on pages 484 - 487.
- Note: Dimensions subject to change. Certified dimensions of ordered material furnished on request.

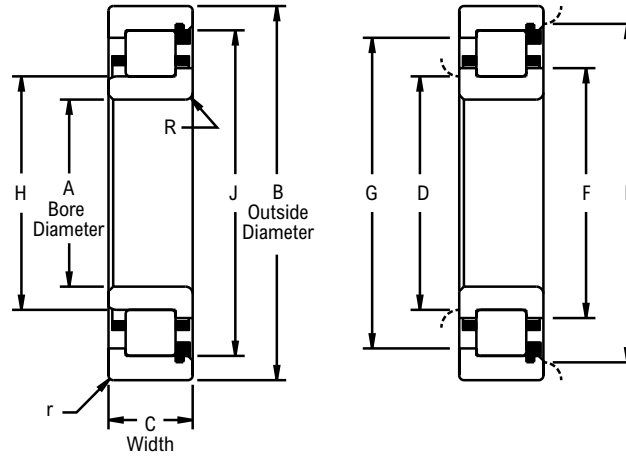
160 mm, 170 mm, 180 mm, 190 mm, 200 mm Bores



Photo Shows an Unmounted Cylindrical Roller Bearing Assembly

Product Features

- Fully crowned rollers
- Precision ground ribs
- Contoured roller pockets
- Rollers individually separated
- Optional full complement
- See Features and Benefits for additional info on page 472.



Bearing Dimensions

Basic Bearing Number	A Bore Diameter		B Outside Diameter		C Bearing Width		D		E		F	G	H	J	R	r
	mm	in	mm	in	mm	in	Plain	Ribbed	Plain	Ribbed						
1932	160.0000	6.2992	220.0000	8.6614	28.0000	1.1024	171.70	175.30	209.30	204.70	181.25	198.96	175.387	204.828	3.18	2.03
1032			240.0000	9.4488	38.0000	1.4961	175.50	179.80	226.60	220.00	187.96	212.17	179.934	220.193	3.96	
1232			290.0000	11.4173	48.0000	1.8898	185.70	193.50	269.50	259.60	205.87	247.83	193.634	259.705	6.35	
5232			98.4250	3.8750												
1934	170.0000	6.6929	230.0000	9.0551	28.0000	1.1024	181.60	185.40	219.20	214.60	191.29	208.99	185.420	214.866	3.18	2.03
1034			260.0000	10.2362	42.0000	1.6535	188.20	193.30	244.10	236.50	202.31	227.81	193.421	236.710	4.75	
1234			310.0000	12.2047	52.0000	2.0472	197.10	205.20	287.50	277.60	219.08	264.74	205.483	277.734	6.35	
5234			104.7750	4.1250												
1936	180.0000	7.0866	250.0000	9.8425	33.0000	1.2992	193.00	197.60	238.20	232.40	204.60	225.68	197.612	232.644	3.96	2.03
1036			280.0000	11.0236	46.0000	1.8110	199.60	205.50	262.90	254.50	215.34	244.80	205.588	254.551	4.75	
1236			320.0000	12.5984	52.0000	2.0472	207.50	216.20	298.20	288.50	229.87	275.56	216.289	288.544	6.35	
5236			107.9500	4.2500												
1938	190.0000	7.4803	260.0000	10.2362	33.0000	1.2992	202.90	182.10	248.40	242.60	214.71	235.79	207.719	242.768	3.96	2.03
1038			290.0000	11.4173	46.0000	1.8110	209.60	215.40	272.80	264.40	225.93	254.23	215.595	264.576	4.75	
1238			340.0000	13.3858	55.0000	2.1654	220.10	229.10	320.37	309.63	244.11	290.48	229.276	309.723	7.42	
5238			114.3000	4.5000												
1940	200.0000	7.8740	280.0000	11.0236	38.0000	1.4961	215.40	220.00	266.40	260.10	227.99	252.22	219.964	260.256	4.75	2.03
1040			310.0000	12.2047	51.0000	2.0079	221.00	227.60	291.30	282.40	238.61	271.58	227.686	282.506	7.92	
1240			360.0000	14.1732	58.0000	2.2835	232.40	242.10	334.50	322.60	257.43	308.20	242.197	322.651	7.92	
5240			120.6500	4.7500												

Additional Notes

- Please call 1-866-REXNORD for availability
- Dimensions "R" & "r", largest fillet radius that will clear bearing corners
- For the Selection Guide, Load Ratings and Speed Limits, see the Link-Belt Cylindrical Roller Bearing Engineering section on pages 474 - 489.
- For shaft and housing bearing seat diameters, see Link-Belt Cylindrical Roller Bearing Shaft & Housing Seat Diameters section on pages 484 - 487.
- Note: Dimensions subject to change. Certified dimensions of ordered material furnished on request.

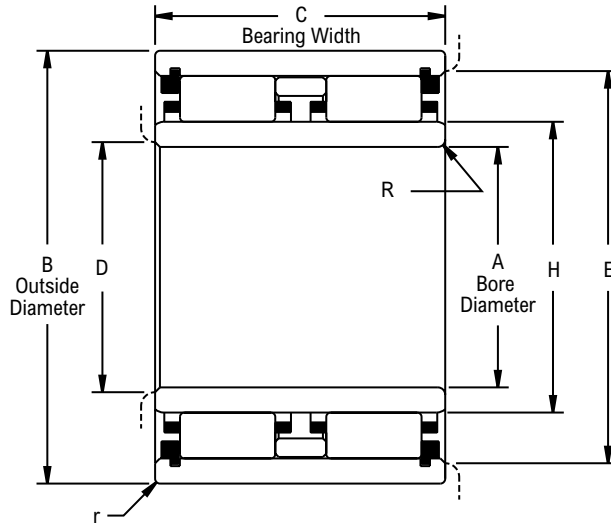
25 mm thru 95 mm Bores



Photo Shows an Unmounted Cylindrical Roller Bearing Assembly

Product Features

- Double row
- Fully crowned rollers
- Contoured roller pockets
- Rollers individually separated
- See Features and Benefits for additional info on page 472.



Bearing Dimensions

Basic Bearing Number	A Bore Diameter		B Outside Diameter		C Bearing Width		D	E	H	J O.R. Raceway I.D.	R	r	C Basic Load Rating	Co Basic Static Load Rating
	mm	in	mm	in	mm	in								
6205	25.0000	0.9843	52.0000	2.0472	41.2750	1.6250	30.50	47.00	32.166	44.854	1.02	1.02	10,200	15,700
6206	30.0000	1.1811	62.0000	2.4409	47.6250	1.8750	36.10	56.40	38.062	54.074	1.02	1.02	15,500	24,300
6207	35.0000	1.3780	72.0000	2.8346	53.9750	2.1250	41.60	65.30	43.970	62.471	1.02	1.02	19,400	30,600
6208	40.0000	1.5748	80.0000	3.1496	60.3250	2.3750	47.20	72.90	49.929	69.619	1.52	1.02	24,600	41,300
6209	45.0000	1.7717	85.0000	3.3465	60.3250	2.3750	52.80	78.20	55.519	74.988	1.52	1.02	26,700	47,500
6210	50.0000	1.9685	90.0000	3.5433	60.3250	2.3750	57.60	82.80	60.460	79.545	1.52	1.02	27,100	50,300
6211	55.0000	2.1654	100.0000	3.9370	66.6750	2.6250	64.00	87.90	66.901	88.019	2.03	1.52	32,900	61,900
6212	60.0000	2.3622	110.0000	4.3307	73.0250	2.8750	69.30	101.30	72.380	97.762	2.03	1.52	42,300	77,700
6213	65.0000	2.5591	120.0000	4.7244	76.2000	3.0000	77.00	110.00	80.421	105.804	2.54	1.52	45,900	88,700
6214	70.0000	2.7559	125.0000	4.9213	79.3750	3.1250	81.80	115.60	84.772	111.536	2.54	1.52	51,300	100,000
6215	75.0000	2.9528	130.0000	5.1181	82.5500	3.2500	85.60	120.10	89.014	115.781	2.54	1.52	55,800	113,000
6216	80.0000	3.1496	140.0000	5.5118	88.9000	3.5000	91.20	129.30	95.286	124.658	2.54	2.03	63,100	127,000
6217	85.0000	3.3465	150.0000	5.9055	98.4250	3.8750	98.00	101.80	102.006	134.216	3.18	2.03	77,600	159,000
6218	90.0000	3.5433	160.0000	6.2992	104.7750	4.1250	103.10	147.60	107.218	142.189	3.18	2.03	87,400	178,000
6219	95.0000	3.7402	170.0000	6.6929	111.1250	4.3750	109.00	157.00	113.518	151.242	3.18	2.03	100,000	206,000

Additional Notes

- Please call 1-866-REXNORD for availability
- Dimensions "R" & "r", largest fillet radius that will clear bearing corners
- For the Selection Guide, Load Ratings and Speed Limits, see the Link-Belt Cylindrical Roller Bearing Engineering section on pages 474 - 489.
- Note: Dimensions subject to change. Certified dimensions of ordered material furnished on request.

Filament Bearings

Standard Sleeves: Rex RPT



Contents

Features and Benefits
Nomenclature
Engineering
Dimensions
 Straight Sleeve

Page

502
503
504
506

Industries Served

Construction
Agriculture
Food
Marine
General Industrial



Rex RPT Bearings

Rex RPT bearings are self-lubricating, non-metallic straight sleeve, round bore bearings in industry standard outside diameter, inside diameter and length dimensions. Ideal for a wide range of wet and dry applications, including aerial lifts, pallet and reach trucks, boat lifts, seeders, tillers, plows, sprayers, fillers and cappers, valves and many more, our bearings offer customers a competitive economical solution for all of their toughest problems. Additionally, customers can count on Rexnord to deliver these in-stock bearings in industry-leading turnaround times of five business days to three weeks.

General Bearing Information:

- Typical dynamic loading from 500 to 12,000 psi
- Operating temperatures from -320 °F to 325 °F (-195.6 °C to 162.8 °C)
- Static and dynamic coefficient of friction from .12 to .06



Features and Benefits

Range of in-stock standard diameter, lengths and wall dimension options

Diameter sizes range from 1/2 inch to 5 inches; lengths are available from 1/4 inch to 10 inches; with wall thicknesses of 1/8 inch and 1/4 inch.

Unique Composition

The non-metallic design combination of Teflon™ fiber, fiberglass and resin offers a corrosion-, moisture-, seizure-, chemical- and fretting-resistant product which reduces downtime and improves productivity.

Rugged Performance

The non-metallic combination is an alternative to metallic bushings that require lubrication in low to moderate load applications. The self-lubricated design maintains peak performance throughout the product life while allowing the customer to eliminate costly lubrication systems.

Lightweight Solution

Rex RPT bearings weigh 77 percent less than steel bearings and 30 percent less than aluminum bearings. This reduced weight offers easier handling and installation and a reduced equipment weight which will lower maintenance costs and provide an extra-long product life.

Variety of Uses

The non-metallic combination allows the Rex RPT bearing to provide electrical insulation as well as reduced noise levels compared to metallic bushings. This bearing can be used on a wide variety of equipment, including underwater applications and other hard to access locations.



▼ Teflon™ is a trademark of The Chemours Company FC, LLC used under license by Toray Fluorofibers (America), Inc.

Nomenclature

Symbol	Description	
		7GP1 - 08 12 - 028
7GP1	Rex RPT Straight Sleeve Bearing	
08	Bearing Nominal ID in sixteenths of an inch (1 inch = 16)	
12	Bearing Nominal OD in sixteenths of an inch (1 inch = 16)	
028	Bearing Length in sixteenths of an inch (1 inch = 016)	

Design and Application Guidelines

The overall performance of filament wound bearings is directly affected by operating factors such as applied loads, operating motions, duty cycle, environmental conditions, installation methods, shaft finish and hardness. While specific design criteria are not available for all applications, certain guidelines must be followed to provide the rated life.

Loads and Ratings

The filament wound back-up material in RPT journal bearings is capable of withstanding static radial load levels as high as 60,000 psi on the projected bearing area. This is in excess of the fabric liner capability of 50,000 psi based on previous experiences. The load deflection relationship of RPT journal bearings and metal-backed Teflon[™] lined bearings is very similar. The yield point and ultimate strength of the filament wound back-up material are approximately equal.

Project Bearing Area (PBA) = I.D. x Length

$$\text{Bearing Stress (PSI)} = \frac{\text{Bearing Load}}{\text{PBA}}$$

Load-life Relationship

Since accumulated wear terminates the useful life of a properly selected Teflon[™] liner bearing, the RPT selection procedure is based on the use of Bearing Area Factors (BAF), rather than load ratings, to select a bearing which meets the combined load-life requirements of the application. The Bearing Area Factor (BAF) is a numerical index of a bearing's dynamic performance ability and is based upon effective bearing area.

RPT bearings are rated on the basis of L10 life expectancy which means that 90% of a given group of bearings will exceed the predicted life. The correlation of load and life is shown in the lower half of the Selection Chart which relates the BAF to cycle of life.

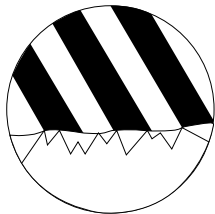
Bearing Area Factor

$$\text{BAF} = \text{I.D.}^{0.491} \times (W - .090)$$

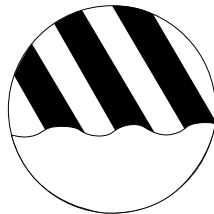
I.D. = Bearing Inner Diameter

W = Bearing Length

All dimensions are in inches



Sharp Machining Marks



Polished Machining Marks

Surface roughness values do not define the character of the finish. Polished shafting (right) normally produces longer bearing life.

Full Rotation

Full rotation can be accommodated if load and speed are below the curve in the following graph. See reference formula for pressure and velocity.

Formulae used in the selection of RPT bearings.

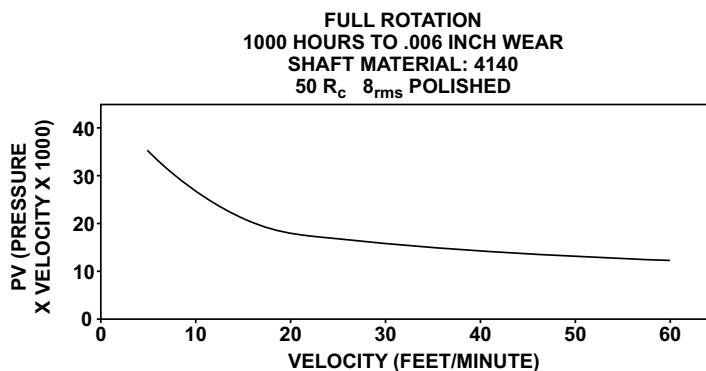
$$\text{Bearing Pressure} \quad \text{PSI} = \frac{\text{Load lbs.}}{\text{I.D.} \times \text{W}}$$

Speed (Surface Velocity)

Full Rotation

$$\text{Surface velocity (Ft/Min)} = .262 \times \text{I.D.} \times \text{RPM}$$

*All dimensions are in inches



Friction

Rex RPT bearings offer low-friction operation. Friction coefficients vary from .12 to .06 depending on the load level. Increased loading results in significant decrease in coefficient of friction. Also, as the bearing "breaks in", the coefficient of friction decreases.

Motion

RPT bearings can withstand various degrees of motion, depending upon speed and load. They will operate under all degrees of motion normally encountered in applications. Note that the degree of oscillation can affect bearing performance and must be taken into account when making a bearing selection, as shown on the nomograph.

Laboratory testing of filament journal bearings has shown their capacity to operate successfully under the low speeds, (less than 90 cycles per minute), high load conditions, (up to 20,000 psi), as well as the high speeds, (up to 300 cpm), light load (less than 5,000 psi) conditions.

Temperature

The normal operating temperature range for RPT bearings is -320 °F to 325 °F. Satisfactory operation can be obtained with limited exposure to temperatures as high as 400 °F. However, at continuous temperatures above 325 °F, an increase in wear rates will be experienced. Contact a Rexnord engineer for applications at cryogenic temperature, as well as for applications.

Shaft Recommendations

Since the shaft surface significantly affects the operation of the journal bearing design, its selection in regard to material, hardness, coating and surface roughness is crucial.

High loads require smooth surfaces with hardened and heat-treated shafts. With stress levels above 8,000 psi, shafting should have a surface finish of 8 micro inch or better to achieve optimum performance. However, tests have been run on 25-30 micro inch finishes with 55 Rc shafts at 4,000 psi with acceptable results.

Shafting Materials

A number of shaft materials have been used in conjunction with RPT bearings:

1. 52100 high carbon steel
2. 4140 chrome and nickel plated steel
3. 300 and 400 series stainless steel
4. Precipitation hardened grades 17-4PH, 15-5PH, 13-8PH Moly chrome and nickel plated stainless steel
5. 2000 and 7000 series aluminum grade hard-anodized
6. Low to high carbon steels

Rex RPT Bearing Selection

The RPT selection graph is designed to handle general applications described by the following parameters:

- Speed not exceeding 60 cycles per minute (12FPM)
- Pressures not exceeding 25,000 psi
- Oscillations 10° and greater, up to 90° included angle

For application requirements exceeding these parameters – consult a Rexnord engineer.

RPT selection problems are typically either: (a) a life calculation where load and size are known or (b) a size selection, where load and required life are known.

Using the selection graph, and following the steps outlined can handle either situation:

Life Calculation – (known load, oscillation and bearing size)

1. Convert oscillation angle to included angle, then follow that line horizontally until it intersects load level.
2. From that point, drop vertically down the chart until the BAF value is intersected. See section Design and Application Guidelines - Load-life relationship for complete explanation of BAF.
3. From that point, follow horizontally and read resulting cycles of life (to .006 wear).

Size Selection – (known load, oscillation and required life)

1. Locate the intersection of the oscillation angle and load lines.
2. Drop vertically down the chart until the required life value is intersected.
3. Determine the required capacity BAF by following the inclined line from that point.
4. Select appropriate size bearing from the thin or heavy series with a BAF in excess of that value, incorporating any known size restrictions – and checking to assure that pin strength (bending) is adequate.

Example – Life Calculation – See graph “BLACK LINES (Dashed)” for example below

Information required to use the selection chart is as follows:

- Oscillation angle ±25 degrees
- Radial Load 15,000 lbs
- Bearing size 1" dia, 5/8" long

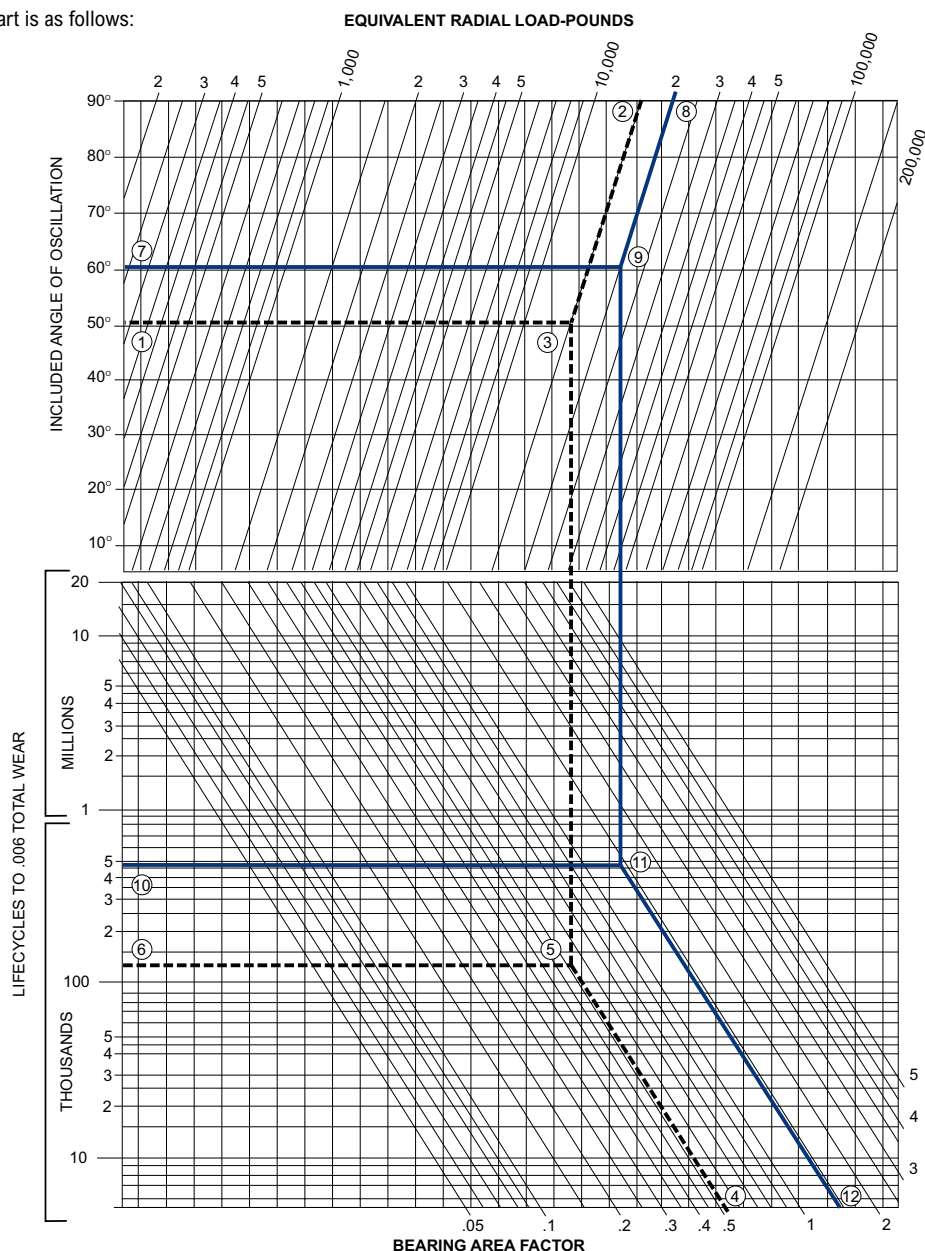
1. Included angle equals the plus and minus motion although the midpoint of the cycle, ±25 degrees equals an included angle of 50 degrees (point 1)
 - a. Radial load equals 15,000 lbs (point 2). These two intersect at (point 3).
2. The BAF for a 1" dia., with 5/8" (.625) width bearing is .536, as found (point 4). This line intersects that (point 3) requirement at (point 5).
3. To determine life to .006 inch wear from chart read the vertical axis value (point 6), which equals 130,000 cycles. Information required to use the selection chart is as follows:

Example – Size Selection – See graph “BLUE LINES (Bolded)” for example below

Information to use chart is as follows:

- Oscillation angle ±30 degrees
- Radial Load 20,000 lbs
- Required life 500,000 cycles
- Size restriction Cannot exceed 1-1/4" dia pin

1. Included angle equals the plus and minus motion through the midpoint of the cycle, thus ±30 degrees equals an included angle of 60 degrees (point 7), the radial load is 20,000 pounds (point 8), and the intersection of angle and load is (point 9).
2. Move down the chart vertically until the 500,000 cycle life (point 10) line is intersected - (point 11).
3. Follow the inclined line and read the required BAF value (point 12) or 1.5.
4. With a required BAF of 1.5, any bearing from the Product Data Sheets that exceeds the value could be selected ie. with a 1-1/4" dia. pin, a 1-1/2" length is required, thus a 7GP1-2024-024. However, if a 1" dia. pin will accept the load, a longer 1-3/4" length is required (7GP1-1620-028). Checking of pin bending strength is appropriate.

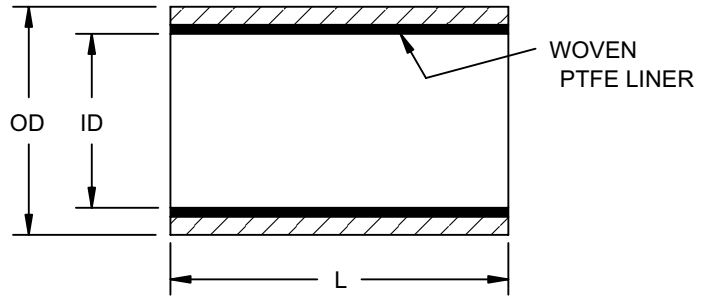


1/8 Inch Wall Straight Sleeve Bearing



Product Features

- Corrosion Resistant
- Self-Lubricating
- Wide Range of Bore sizes and lengths
- Lightweight Teflon and Polyester Construction
- Operating Temps: -320 °F to 325 °F
- Underwater Operation Capability

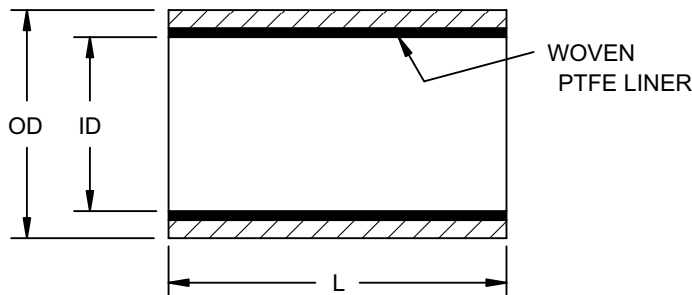


Bearing Dimensions

Bore Size	Part Number	ID	OD	Recommended Sizes			Model Number Suffix													Maximum Length
				Housing Bore	Max Shaft Dia	Wt (Ref) Lb/in.	L= Length Suffix in Multiples of 1/16" (Tolerance +/- .010)													
							0.250	0.500	0.750	1.000	1.250	1.500	1.0750	2.000	2.250	2.500	2.750	3.000		
1/2	7GP1-0812-XXX	0.506	0.7535	0.7500	0.5000	0.0173	-004	-008	-012	-016	-020	-024	-028	-032	-036	-040	-044	-048	6.000	
		0.507	0.7525	0.7505			-004	-008	-012	-016	-020	-024	-028	-032	-036	-040	-044	-048		
5/8	7GP1-1014-XXX	0.631	0.8785	0.8750	0.6250	0.0207	-004	-008	-012	-016	-020	-024	-028	-032	-036	-040	-044	-048	10.000	
		0.632	0.8775	0.8755			-004	-008	-012	-016	-020	-024	-028	-032	-036	-040	-044	-048		
3/4	7GP1-1216-XXX	0.756	1.0035	1.0000	0.7500	0.0242	-004	-008	-012	-016	-020	-024	-028	-032	-036	-040	-044	-048	10.000	
		0.757	1.0025	1.0005			-004	-008	-012	-016	-020	-024	-028	-032	-036	-040	-044	-048		
7/8	7GP1-1418-XXX	0.881	1.1285	1.1250	0.8750	0.0276	-004	-008	-012	-016	-020	-024	-028	-032	-036	-040	-044	-048	10.000	
		0.882	1.1275	1.1255			-004	-008	-012	-016	-020	-024	-028	-032	-036	-040	-044	-048		
1	7GP1-1620-XXX	1.006	1.2535	1.2500	1.0000	0.0311	-004	-008	-012	-016	-020	-024	-028	-032	-036	-040	-044	-048	10.000	
		1.007	1.2525	1.2505			-004	-008	-012	-016	-020	-024	-028	-032	-036	-040	-044	-048		
1 1/8	7GP1-1822-XXX	1.131	1.3785	1.3750	1.1250	0.0345	-004	-008	-012	-016	-020	-024	-028	-032	-036	-040	-044	-048	10.000	
		1.132	1.3775	1.3755			-004	-008	-012	-016	-020	-024	-028	-032	-036	-040	-044	-048		
1 1/4	7GP1-2024-XXX	1.256	1.5035	1.5000	1.2500	0.0379	-004	-008	-012	-016	-020	-024	-028	-032	-036	-040	-044	-048	10.000	
		1.257	1.5025	1.5005			-004	-008	-012	-016	-020	-024	-028	-032	-036	-040	-044	-048		
1 3/8	7GP1-2226-XXX	1.381	1.6285	1.6250	1.3750	0.0414	-004	-008	-012	-016	-020	-024	-028	-032	-036	-040	-044	-048	10.000	
		1.382	1.6275	1.6255			-004	-008	-012	-016	-020	-024	-028	-032	-036	-040	-044	-048		
1 1/2	7GP1-2428-XXX	1.506	1.7535	1.7500	1.5000	0.0448	-004	-008	-012	-016	-020	-024	-028	-032	-036	-040	-044	-048	10.000	
		1.507	1.7525	1.7505			-004	-008	-012	-016	-020	-024	-028	-032	-036	-040	-044	-048		
1 5/8	7GP1-2630-XXX	1.631	1.8785	1.8750	1.6250	0.0482	-004	-008	-012	-016	-020	-024	-028	-032	-036	-040	-044	-048	10.000	
		1.632	1.8775	1.8755			-004	-008	-012	-016	-020	-024	-028	-032	-036	-040	-044	-048		
1 3/4	7GP1-2832-XXX	1.757	2.0035	2.0000	1.7500	0.0515	-004	-008	-012	-016	-020	-024	-028	-032	-036	-040	-044	-048	10.000	
		1.758	2.0025	2.0005			-004	-008	-012	-016	-020	-024	-028	-032	-036	-040	-044	-048		
1 7/8	7GP1-3034-XXX	1.882	2.1285	2.1250	1.8750	0.0549	-004	-008	-012	-016	-020	-024	-028	-032	-036	-040	-044	-048	10.000	
		1.883	2.1275	2.1255			-004	-008	-012	-016	-020	-024	-028	-032	-036	-040	-044	-048		
2	7GP1-3236-XXX	2.0085	2.2545	2.2500	2.0000	0.0582	-004	-008	-012	-016	-020	-024	-028	-032	-036	-040	-044	-048	10.000	
		2.0095	2.2535	2.2510			-004	-008	-012	-016	-020	-024	-028	-032	-036	-040	-044	-048		
2 1/8	7GP1-3438-XXX	2.1335	2.3795	2.3750	2.1250	0.0614	-004	-008	-012	-016	-020	-024	028	-032	-036	-040	-044	-048	10.000	
		2.1345	2.3785	2.3760			-004	-008	-012	-016	-020	-024	-028	-032	-036	-040	-044	-048		
2 1/4	7GP1-3640-XXX	2.2585	2.5045	2.5000	2.2500	0.0648	-004	-008	-012	-016	-020	-024	-028	-032	-036	-040	-044	-048	10.000	
		2.2595	2.5035	2.5010			-004	-008	-012	-016	-020	-024	-028	-032	-036	-040	-044	-048		
2 3/8	7GP1-3842-XXX	2.3835	2.6295	2.6250	2.3750	0.0682	-004	-008	-012	-016	-020	-024	-028	-032	-036	-040	-044	-048	10.000	
		2.3845	2.6285	2.6260			-004	-008	-012	-016	-020	-024	-028	-032	-036	-040	-044	-048		
2 1/2	7GP1-4044-XXX	2.509	2.7545	2.7500	2.5000	0.0714	-004	-008	-012	-016	-020	-024	-028	-032	-036	-040	-044	-048	10.000	
		2.510	2.7535	2.7510			-004	-008	-012	-016	-020	-024	-028	-032	-036	-040	-044	-048		
2 3/4	7GP1-4448-XXX	2.759	3.005	3.0000	2.7500	0.0784	-004	-008	-012	-016	-020	-024	-028	-032	-036	-040	-044	-048	10.000	
		2.760	3.004	3.0015			-004	-008	-012	-016	-020	-024	-028	-032	-036	-040	-044	-048		
3	7GP1-4852-XXX	3.0080	3.255	3.2500	3.0000	0.0854		-008	-012	-016	-020	-024	-028	-032	-036	-040	-044	-048	10.000	
		3.0105	3.254	3.2515				-008	-012	-016	-020	-024	-028	-032	-036	-040	-044	-048		
3 1/4	7GP1-5256-XXX	3.2580	3.5055	3.5000	3.2500	0.0925		-008	-012	-016	-020	-024	-028	-032	-036	-040	-044	-048	10.000	
		3.2605	3.5045	3.5020				-008	-012	-016	-020	-024	-028	-032	-036	-040	-044	-048		
3 1/2	7GP1-5660-XXX	3.5080	3.7555	3.7500	3.5000	0.0994		-008	-012	-016	-020	-024	-028	-032	-036	-040	-044	-048	10.000	
		3.5105	3.7545	3.7520				-008	-012	-016	-020	-024	-028	-032	-036	-040	-044	-048		
3 3/4	7GP1-6064-XXX	3.7580	4.0055	4.0000	3.7500	0.1062		-008	-012	-016	-020	-024	-028	-032	-036	-040	-044	-048	10.000	
		3.7605	4.0045	4.0020				-008	-012	-016	-020	-024	-028	-032	-036	-040	-044	-048		
4	7GP1-6468-XXX	4.011	4.257	4.2500	4.0000	0.1124		-008	-012	-016	-020	-024	-028	-032	-036	-040	-044	-048	10.000	
		4.014	4.256	4.2520				-008	-012	-016	-020	-024	-028	-032	-036	-040	-044	-048		
4 1/4	7GP1-6872-XXX	4.261	4.507	4.5000	4.2500	0.1186		-008	-012	-016	-020	-024	-028	-032	-036	-040	-044	-048	10.000	
		4.264	4.506	4.5020				-008	-012	-016	-020	-024	-028	-032	-036	-040	-044	-048		
4 1/2	7GP1-7276-XXX	4.511	4.757	4.7500	4.5000	0.1253		-008	-012	-016	-020	-024	-028	-032	-036	-040	-044	-048	10.000	
		4.514	4.756	4.7520				-008	-012	-016	-020	-024	-028	-032	-036	-040	-044	-048		
4 3/4	7GP1-7680-XXX	4.761	5.007	5.0000	4.7500	0.1321		-008	-012	-016	-020	-024	-028	-032	-036	-040	-044	-048	10.000	
		4.764	5.006	5.0020				-008	-012	-016	-020	-024	-028	-032	-036	-040	-044	-048		
5	7GP1-8084-XXX	5.0105	5.257	5.2500	5.0000	0.1391		-008	-012	-016	-020	-024	-028	-032	-036	-040	-044	-048	10.000	
		5.0140	5.256	5.2520				-008	-012	-016	-020	-024	-028	-032	-036	-040	-044	-048		

Standard MODEL SIZES are noted in BLACK. For MODEL SIZES in (BOLD) and shaded (Gray) consult with Rexnord Rex RPT Engineering.

1/8 Inch Wall Straight Sleeve Bearing (Continued)



Continued...

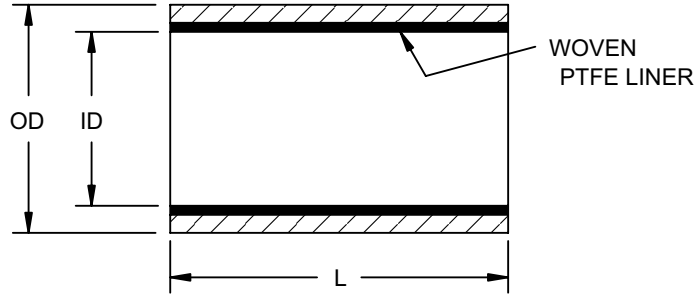
Bearing Dimensions

Bore Size	Part Number	ID	OD	Recommended Sizes			Model Number Suffix													Maximum Length
				Housing Bore	Max Shaft Dia	Wt (Ref) Lb/In.	L= Length Suffix in Multiples of 1/16" (Tolerance +/- .010)													
							3.250	3.500	3.750	4.000	4.250	4.500	4.750	5.000	5.250	5.500	5.750	6.000		
1/2	7GP1-0812-XXX	0.506	0.7535	0.7500	0.5000	0.0173	-052	-056	-060	-064	-068	-072	-076	-080	-084	-088	-092	-096	6.000	
		0.507	0.7525	0.7505																
5/8	7GP1-1014-XXX	0.631	0.8785	0.8750	0.6250	0.0207	-052	-056	-060	-064	-068	-072	-076	-080	-084	-088	-092	-096	10.000	
		0.632	0.8775	0.8755																
3/4	7GP1-1216-XXX	0.756	1.0035	1.0000	0.7500	0.0242	-052	-056	-060	-064	-068	-072	-076	-080	-084	-088	-092	-096	10.000	
		0.757	1.0025	1.0005																
7/8	7GP1-1418-XXX	0.881	1.1285	1.1250	0.8750	0.0276	-052	-056	-060	-064	-068	-072	-076	-080	-084	-088	-092	-096	10.000	
		0.882	1.1275	1.1255																
1	7GP1-1620-XXX	1.006	1.2535	1.2500	1.0000	0.0311	-052	-056	-060	-064	-068	-072	-076	-080	-084	-088	-092	-096	10.000	
		1.007	1.2525	1.2505																
1 1/8	7GP1-1822-XXX	1.131	1.3785	1.3750	1.1250	0.0345	-052	-056	-060	-064	-068	-072	-076	-080	-084	-088	-092	-096	10.000	
		1.132	1.3775	1.3755																
1 1/4	7GP1-2024-XXX	1.256	1.5035	1.5000	1.2500	0.0379	-052	-056	-060	-064	-068	-072	-076	-080	-084	-088	-092	-096	10.000	
		1.257	1.5025	1.5005																
1 3/8	7GP1-2226-XXX	1.381	1.6285	1.6250	1.3750	0.0414	-052	-056	-060	-064	-068	-072	-076	-080	-084	-088	-092	-096	10.000	
		1.382	1.6275	1.6255																
1 1/2	7GP1-2428-XXX	1.506	1.7535	1.7500	1.5000	0.0448	-052	-056	-060	-064	-068	-072	-076	-080	-084	-088	-092	-096	10.000	
		1.507	1.7525	1.7505																
1 5/8	7GP1-2630-XXX	1.631	1.8785	1.8750	1.6250	0.0482	-052	-056	-060	-064	-068	-072	-076	-080	-084	-088	-092	-096	10.000	
		1.632	1.8775	1.8755																
1 3/4	7GP1-2832-XXX	1.757	2.0035	2.0000	1.7500	0.0515	-052	-056	-060	-064	-068	-072	-076	-080	-084	-088	-092	-096	10.000	
		1.758	2.0025	2.0005																
1 7/8	7GP1-3034-XXX	1.882	2.1285	2.1250	1.8750	0.0549	-052	-056	-060	-064	-068	-072	-076	-080	-084	-088	-092	-096	10.000	
		1.883	2.1275	2.1255																
2	7GP1-3236-XXX	2.0085	2.2545	2.2500	2.0000	0.0582	-052	-056	-060	-064	-068	-072	-076	-080	-084	-088	-092	-096	10.000	
		2.0095	2.2535	2.2510																
2 1/8	7GP1-3438-XXX	2.1335	2.3795	2.3750	2.1250	0.0614	-052	-056	-060	-064	-068	-072	-076	-080	-084	-088	-092	-096	10.000	
		2.1345	2.3785	2.3760																
2 1/4	7GP1-3640-XXX	2.2585	2.5045	2.5000	2.2500	0.0648	-052	-056	-060	-064	-068	-072	-076	-080	-084	-088	-092	-096	10.000	
		2.2595	2.5035	2.5010																
2 3/8	7GP1-3842-XXX	2.3835	2.6295	2.6250	2.3750	0.0682	-052	-056	-060	-064	-068	-072	-076	-080	-084	-088	-092	-096	10.000	
		2.3845	2.6285	2.6260																
2 1/2	7GP1-4044-XXX	2.509	2.7545	2.7500	2.5000	0.0714	-052	-056	-060	-064	-068	-072	-076	-080	-084	-088	-092	-096	10.000	
		2.510	2.7535	2.7510																
2 3/4	7GP1-4448-XXX	2.759	3.005	3.0000	2.7500	0.0784	-052	-056	-060	-064	-068	-072	-076	-080	-084	-088	-092	-096	10.000	
		2.760	3.004	3.0015																
3	7GP1-4852-XXX	3.0080	3.255	3.2500	3.0000	0.0854	-052	-056	-060	-064	-068	-072	-076	-080	-084	-088	-092	-096	10.000	
		3.0105	3.254	3.2515																
3 1/4	7GP1-5256-XXX	3.2580	3.5055	3.5000	3.2500	0.0925	-052	-056	-060	-064	-068	-072	-076	-080	-084	-088	-092	-096	10.000	
		3.2605	3.5045	3.5020																
3 1/2	7GP1-5660-XXX	3.5080	3.7555	3.7500	3.5000	0.0994	-052	-056	-060	-064	-068	-072	-076	-080	-084	-088	-092	-096	10.000	
		3.5105	3.7545	3.7520																
3 3/4	7GP1-6064-XXX	3.7580	4.0055	4.0000	3.7500	0.1062	-052	-056	-060	-064	-068	-072	-076	-080	-084	-088	-092	-096	10.000	
		3.7605	4.0045	4.0020																
4	7GP1-6468-XXX	4.011	4.257	4.2500	4.0000	0.1124	-052	-056	-060	-064	-068	-072	-076	-080	-084	-088	-092	-096	10.000	
		4.014	4.256	4.2520																
4 1/4	7GP1-6872-XXX	4.261	4.507	4.5000	4.2500	0.1186	-052	-056	-060	-064	-068	-072	-076	-080	-084	-088	-092	-096	10.000	
		4.264	4.506	4.5020																
4 1/2	7GP1-7276-XXX	4.511	4.757	4.7500	4.5000	0.1253	-052	-056	-060	-064	-068	-072	-076	-080	-084	-088	-092	-096	10.000	
		4.514	4.756	4.7520																
4 3/4	7GP1-7680-XXX	4.761	5.007	5.0000	4.7500	0.1321	-052	-056	-060	-064	-068	-072	-076	-080	-084	-088	-092	-096	10.000	
		4.764	5.006	5.0020																
5	7GP1-8084-XXX	5.0105	5.257	5.2500	5.0000	0.1391	-052	-056	-060	-064	-068	-072	-076	-080	-084	-088	-092	-096	10.000	
		5.0140	5.256	5.2520																

Standard MODEL SIZES are noted in BLACK. For MODEL SIZES in (BOLD) and shaded (Gray) consult with Rexnord Rex RPT Engineering.

Continued...

1/8 Inch Wall Straight Sleeve Bearing (Continued)



Continued...

Bearing Dimensions

Bore Size	Part Number	ID	OD	Recommended Sizes			Model Number Suffix								Maximum Length
				Housing Bore	Max Shaft Dia	Wt (Ref) Lb/in.	L= Length Suffix in Multiples of 1/16" (Tolerance +/- .010)								
							6.500	7.000	7.500	8.000	8.500	9.000	9.500	10.000 +/- .025	
1/2	7GP1-0812-XXX	0.506	0.7535	0.7500	0.5000	0.0173									6.000
		0.507	0.7525	0.7505											
5/8	7GP1-1014-XXX	0.631	0.8785	0.8750	0.6250	0.0207	-104	-112	-120	-128	-136	-144	-152	-160	10.000
		0.632	0.8775	0.8755											
3/4	7GP1-1216-XXX	0.756	1.0035	1.0000	0.7500	0.0242	-104	-112	-120	-128	-136	-144	-152	-160	10.000
		0.757	1.0025	1.0005											
7/8	7GP1-1418-XXX	0.881	1.1285	1.1250	0.8750	0.0276	-104	-112	-120	-128	-136	-144	-152	-160	10.000
		0.882	1.1275	1.1255											
1	7GP1-1620-XXX	1.006	1.2535	1.2500	1.0000	0.0311	-104	-112	-120	-128	-136	-144	-152	-160	10.000
		1.007	1.2525	1.2505											
1 1/8	7GP1-1822-XXX	1.131	1.3785	1.3750	1.1250	0.0345	-104	-112	-120	-128	-136	-144	-152	-160	10.000
		1.132	1.3775	1.3755											
1 1/4	7GP1-2024-XXX	1.256	1.5035	1.5000	1.2500	0.0379	-104	-112	-120	-128	-136	-144	-152	-160	10.000
		1.257	1.5025	1.5005											
1 3/8	7GP1-2226-XXX	1.381	1.6285	1.6250	1.3750	0.0414	-104	-112	-120	-128	-136	-144	-152	-160	10.000
		1.382	1.6275	1.6255											
1 1/2	7GP1-2428-XXX	1.506	1.7535	1.7500	1.5000	0.0448	-104	-112	-120	-128	-136	-144	-152	-160	10.000
		1.507	1.7525	1.7505											
1 5/8	7GP1-2630-XXX	1.631	1.8785	1.8750	1.6250	0.0482	-104	-112	-120	-128	-136	-144	-152	-160	10.000
		1.632	1.8775	1.8755											
1 3/4	7GP1-2832-XXX	1.757	2.0035	2.0000	1.7500	0.0515	-104	-112	-120	-128	-136	-144	-152	-160	10.000
		1.758	2.0025	2.0005											
1 7/8	7GP1-3034-XXX	1.882	2.1285	2.1250	1.8750	0.0549	-104	-112	-120	-128	-136	-144	-152	-160	10.000
		1.883	2.1275	2.1255											
2	7GP1-3236-XXX	2.0085	2.2545	2.2500	2.0000	0.0582	-104	-112	-120	-128	-136	-144	-152	-160	10.000
		2.0095	2.2535	2.2510											
2 1/8	7GP1-3438-XXX	2.1335	2.3795	2.3750	2.1250	0.0614	-104	-112	-120	-128	-136	-144	-152	-160	10.000
		2.1345	2.3785	2.3760											
2 1/4	7GP1-3640-XXX	2.2585	2.5045	2.5000	2.2500	0.0648	-104	-112	-120	-128	-136	-144	-152	-160	10.000
		2.2595	2.5035	2.5010											
2 3/8	7GP1-3842-XXX	2.3835	2.6295	2.6250	2.3750	0.0682	-104	-112	-120	-128	-136	-144	-152	-160	10.000
		2.3845	2.6285	2.6260											
2 1/2	7GP1-4044-XXX	2.509	2.7545	2.7500	2.5000	0.0714	-104	-112	-120	-128	-136	-144	-152	-160	10.000
		2.510	2.7535	2.7510											
2 3/4	7GP1-4448-XXX	2.759	3.005	3.0000	2.7500	0.0784	-104	-112	-120	-128	-136	-144	-152	-160	10.000
		2.760	3.004	3.0015											
3	7GP1-4852-XXX	3.0080	3.255	3.2500	3.0000	0.0854	-104	-112	-120	-128	-136	-144	-152	-160	10.000
		3.0105	3.254	3.2515											
3 1/4	7GP1-5256-XXX	3.2580	3.5055	3.5000	3.2500	0.0925	-104	-112	-120	-128	-136	-144	-152	-160	10.000
		3.2605	3.5045	3.5020											
3 1/2	7GP1-5660-XXX	3.5080	3.7555	3.7500	3.5000	0.0994	-104	-112	-120	-128	-136	-144	-152	-160	10.000
		3.5105	3.7545	3.7520											
3 3/4	7GP1-6064-XXX	3.7580	4.0055	4.0000	3.7500	0.1062	-104	-112	-120	-128	-136	-144	-152	-160	10.000
		3.7605	4.0045	4.0020											
4	7GP1-6468-XXX	4.011	4.257	4.2500	4.0000	0.1124	-104	-112	-120	-128	-136	-144	-152	-160	10.000
		4.014	4.256	4.2520											
4 1/4	7GP1-6872-XXX	4.261	4.507	4.5000	4.2500	0.1186	-104	-112	-120	-128	-136	-144	-152	-160	10.000
		4.264	4.506	4.5020											
4 1/2	7GP1-7276-XXX	4.511	4.757	4.7500	4.5000	0.1253	-104	-112	-120	-128	-136	-144	-152	-160	10.000
		4.514	4.756	4.7520											
4 3/4	7GP1-7680-XXX	4.761	5.007	5.0000	4.7500	0.1321	-104	-112	-120	-128	-136	-144	-152	-160	10.000
		4.764	5.006	5.0020											
5	7GP1-8084-XXX	5.0105	5.257	5.2500	5.0000	0.1391	-104	-112	-120	-128	-136	-144	-152	-160	10.000
		5.0140	5.256	5.2520											

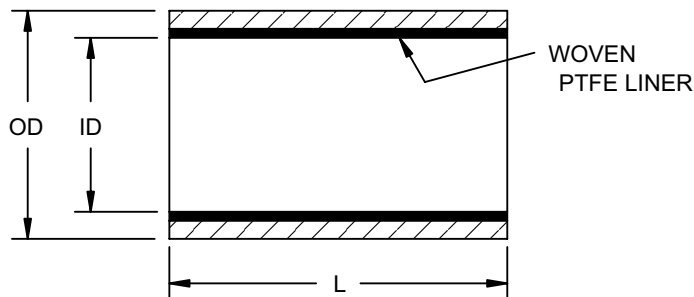
Standard MODEL SIZES are noted in BLACK. For MODEL SIZES in (BOLD) and shaded (Gray) consult with Rexnord Rex RPT Engineering.

1/4 Inch Wall Straight Sleeve Bearing



Product Features

- Corrosion Resistant
- Self-Lubricating
- Wide Range of Bore sizes and lengths
- Lightweight Teflon™ and Polyester Construction
- Operating Temps: -320 °F to 325 °F
- Underwater Operation Capability



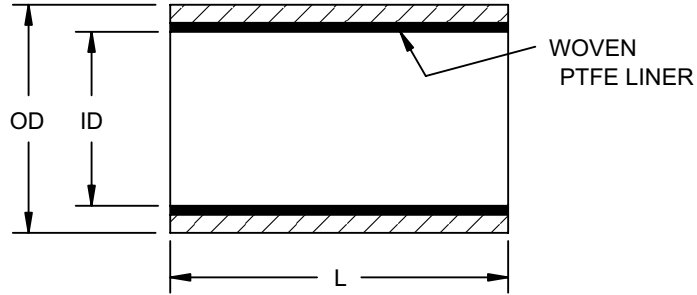
Bearing Dimensions

Bore Size	Part Number	ID	OD	Recommended Sizes			Model Number Suffix													Maximum Length
				Housing Bore	Max Shaft Dia	Wt (Ref) Lb/In.	L= Length Suffix in Multiples of 1/16" (Tolerance +/- .010)													
							0.250	0.500	0.750	1.000	1.250	1.500	1.0750	2.000	2.250	2.500	2.750	3.000		
1/2	7GP1-0816-XXX	0.506	1.0035	1.0000	0.5000	0.0417	-004	-008	-012	-016	-020	-024	-028	-032	-036	-040	-044	-048	6.000	
		0.507	1.0025	1.0005																
5/8	7GP1-1018-XXX	0.631	1.1285	1.1250	0.6250	0.0486	-004	-008	-012	-016	-020	-024	-028	-032	-036	-040	-044	-048	10.000	
		0.632	1.1275	1.1255																
3/4	7GP1-1220-XXX	0.756	1.2535	1.2500	0.7500	0.0555	-004	-008	-012	-016	-020	-024	-028	-032	-036	-040	-044	-048	10.000	
		0.757	1.2525	1.2505																
7/8	7GP1-1422-XXX	0.881	1.3785	1.3750	0.8750	0.0624	-004	-008	-012	-016	-020	-024	-028	-032	-036	-040	-044	-048	10.000	
		0.882	1.3775	1.3755																
1	7GP1-1624-XXX	1.006	1.5035	1.5000	1.0000	0.0693	-004	-008	-012	-016	-020	-024	-028	-032	-036	-040	-044	-048	10.000	
		1.007	1.5025	1.5005																
1 1/8	7GP1-1826-XXX	1.131	1.6285	1.6250	1.1250	0.0762	-004	-008	-012	-016	-020	-024	-028	-032	-036	-040	-044	-048	10.000	
		1.132	1.6275	1.6255																
1 1/4	7GP1-2028-XXX	1.256	1.7535	1.7500	1.2500	0.0831	-004	-008	-012	-016	-020	-024	-028	-032	-036	-040	-044	-048	10.000	
		1.257	1.7525	1.7505																
1 3/8	7GP1-2230-XXX	1.381	1.8785	1.8750	1.3750	0.0900	-004	-008	-012	-016	-020	-024	-028	-032	-036	-040	-044	-048	10.000	
		1.382	1.8775	1.8755																
1 1/2	7GP1-2432-XXX	1.506	2.0035	2.0000	1.5000	0.0970	-004	-008	-012	-016	-020	-024	-028	-032	-036	-040	-044	-048	10.000	
		1.507	2.0025	2.0005																
1 5/8	7GP1-2634-XXX	1.631	2.1285	2.1250	1.6250	0.1039	-004	-008	-012	-016	-020	-024	-028	-032	-036	-040	-044	-048	10.000	
		1.632	1.1275	1.1255																
1 3/4	7GP1-2836-XXX	1.757	2.2545	2.2500	1.7500	0.1108	-004	-008	-012	-016	-020	-024	-028	-032	-036	-040	-044	-048	10.000	
		1.758	2.2535	2.2510																
1 7/8	7GP1-3038-XXX	1.882	2.3795	2.3750	1.8750	0.1177	-004	-008	-012	-016	-020	-024	-028	-032	-036	-040	-044	-048	10.000	
		1.883	2.3785	2.3760																
2	7GP1-3240-XXX	2.0085	2.5045	2.5000	2.0000	0.1243	-004	-008	-012	-016	-020	-024	-028	-032	-036	-040	-044	-048	10.000	
		2.0095	2.5035	2.5010																
2 1/8	7GP1-3442-XXX	2.1335	2.6295	2.6250	2.1250	0.1306	-004	-008	-012	-016	-020	-024	028	-032	-036	-040	-044	-048	10.000	
		2.1345	2.6285	2.6260																
2 1/4	7GP1-3644-XXX	2.2585	2.7545	2.7500	2.2500	0.1374	-004	-008	-012	-016	-020	-024	-028	-032	-036	-040	-044	-048	10.000	
		2.2595	2.7535	2.7510																
2 3/8	7GP1-3846-XXX	2.3835	2.8795	2.8750	2.3750	0.1442	-004	-008	-012	-016	-020	-024	-028	-032	-036	-040	-044	-048	10.000	
		2.3845	2.8785	2.8760																
2 1/2	7GP1-4048-XXX	2.509	3.005	3.0000	2.5000	0.1511	-004	-008	-012	-016	-020	-024	-028	-032	-036	-040	-044	-048	10.000	
		2.510	3.004	3.0015																
2 3/4	7GP1-4452-XXX	2.759	3.255	3.2500	2.7500	0.1648	-004	-008	-012	-016	-020	-024	-028	-032	-036	-040	-044	-048	10.000	
		2.760	3.254	3.2515																
3	7GP1-4856-XXX	3.0080	3.5055	3.5000	3.0000	0.1790		-008	-012	-016	-020	-024	-028	-032	-036	-040	-044	-048	10.000	
		3.0105	3.5045	3.5020																
3 1/4	7GP1-5260-XXX	3.2580	3.3755	3.7500	3.2500	0.1928		-008	-012	-016	-020	-024	-028	-032	-036	-040	-044	-048	10.000	
		3.2605	3.3745	3.7520																
3 1/2	7GP1-5664-XXX	3.5080	4.0055	4.0000	3.5000	0.2066		-008	-012	-016	-020	-024	-028	-032	-036	-040	-044	-048	10.000	
		3.5105	4.0045	4.0020																
3 3/4	7GP1-6068-XXX	3.7580	4.2555	4.2500	3.7500	0.2203		-008	-012	-016	-020	-024	-028	-032	-036	-040	-044	-048	10.000	
		3.7605	4.2545	4.2520																
4	7GP1-6472-XXX	4.011	4.507	4.5000	4.0000	0.2334		-008	-012	-016	-020	-024	-028	-032	-036	-040	-044	-048	10.000	
		4.014	4.506	4.5020																
4 1/4	7GP1-6876-XXX	4.261	4.757	4.7500	4.2500	0.2459		-008	-012	-016	-020	-024	-028	-032	-036	-040	-044	-048	10.000	
		4.264	4.756	4.7520																
4 1/2	7GP1-7280-XXX	4.511	5.007	5.0000	4.5000	0.2596		-008	-012	-016	-020	-024	-028	-032	-036	-040	-044	-048	10.000	
		4.514	5.006	5.0020																
4 3/4	7GP1-7684-XXX	4.761	5.257	5.2500	4.7500	0.2732		-008	-012	-016	-020	-024	-028	-032	-036	-040	-044	-048	10.000	
		4.764	5.256	5.2520																
5	7GP1-8088-XXX	5.0105	5.507	5.5000	5.0000	0.2871		-008	-012	-016	-020	-024	-028	-032	-036	-040	-044	-048	10.000	
		5.0140	5.506	5.5020																

Standard MODEL SIZES are noted in BLACK. For MODEL SIZES in (BOLD) and shaded (Gray) consult with Rexnord Rex RPT Engineering.

Continued...

1/4 Inch Wall Straight Sleeve Bearing (Continued)



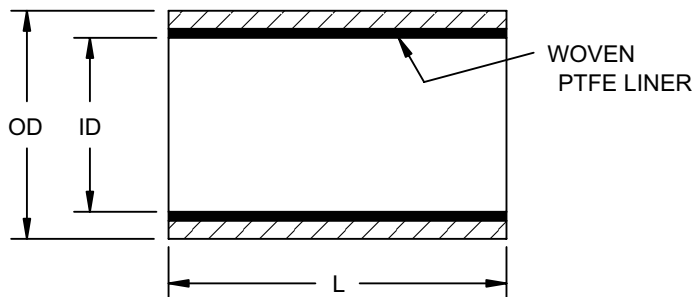
Continued..

Bearing Dimensions

Bore Size	Part Number	ID	OD	Recommended Sizes			Model Number Suffix												Maximum Length
				Housing Bore	Max Shaft Dia	Wt (Ref) Lb/in.	L= Length Suffix in Multiples of 1/16" (Tolerance +/- .010)												
							3.250	3.500	3.750	4.000	4.250	4.500	4.750	5.000	5.250	5.500	5.750	6.000	
1/2	7GP1-0816-XXX	0.506	1.0035	1.0000	0.5000	0.0417	-052	-056	-060	-064	-068	-072	-076	-080	-084	-088	-092	-096	6.000
		0.507	1.0025	1.0005															
5/8	7GP1-1018-XXX	0.631	1.1285	1.1250	0.6250	0.0486	-052	-056	-060	-064	-068	-072	-076	-080	-084	-088	-092	-096	10.000
		0.632	1.1275	1.1255															
3/4	7GP1-1220-XXX	0.756	1.2535	1.2500	0.7500	0.0555	-052	-056	-060	-064	-068	-072	-076	-080	-084	-088	-092	-096	10.000
		0.757	1.2525	1.2505															
7/8	7GP1-1422-XXX	0.881	1.3785	1.3750	0.8750	0.0624	-052	-056	-060	-064	-068	-072	-076	-080	-084	-088	-092	-096	10.000
		0.882	1.3775	1.3755															
1	7GP1-1624-XXX	1.006	1.5035	1.5000	1.0000	0.0693	-052	-056	-060	-064	-068	-072	-076	-080	-084	-088	-092	-096	10.000
		1.007	1.5025	1.5005															
1 1/8	7GP1-1826-XXX	1.131	1.6285	1.6250	1.1250	0.0762	-052	-056	-060	-064	-068	-072	-076	-080	-084	-088	-092	-096	10.000
		1.132	1.6275	1.6255															
1 1/4	7GP1-2028-XXX	1.256	1.7535	1.7500	1.2500	0.0831	-052	-056	-060	-064	-068	-072	-076	-080	-084	-088	-092	-096	10.000
		1.257	1.7525	1.7505															
1 3/8	7GP1-2230-XXX	1.381	1.8785	1.8750	1.3750	0.0900	-052	-056	-060	-064	-068	-072	-076	-080	-084	-088	-092	-096	10.000
		1.382	1.8775	1.8755															
1 1/2	7GP1-2432-XXX	1.506	2.0035	2.0000	1.5000	0.0970	-052	-056	-060	-064	-068	-072	-076	-080	-084	-088	-092	-096	10.000
		1.507	2.0025	2.0005															
1 5/8	7GP1-2634-XXX	1.631	2.1285	2.1250	1.6250	0.1039	-052	-056	-060	-064	-068	-072	-076	-080	-084	-088	-092	-096	10.000
		1.632	1.1275	2.1255															
1 3/4	7GP1-2836-XXX	1.757	2.2545	2.2500	1.7500	0.1108	-052	-056	-060	-064	-068	-072	-076	-080	-084	-088	-092	-096	10.000
		1.758	2.2535	2.2510															
1 7/8	7GP1-3038-XXX	1.882	2.3795	2.3750	1.8750	0.1177	-052	-056	-060	-064	-068	-072	-076	-080	-084	-088	-092	-096	10.000
		1.883	2.3785	2.3760															
2	7GP1-3240-XXX	2.0085	2.5045	2.5000	2.0000	0.1243	-052	-056	-060	-064	-068	-072	-076	-080	-084	-088	-092	-096	10.000
		2.0095	2.5035	2.5010															
2 1/8	7GP1-3442-XXX	2.1335	2.6295	2.6250	2.1250	0.1306	-052	-056	-060	-064	-068	-072	-076	-080	-084	-088	-092	-096	10.000
		2.1345	2.6285	2.6260															
2 1/4	7GP1-3644-XXX	2.2585	2.7545	2.7500	2.2500	0.1374	-052	-056	-060	-064	-068	-072	-076	-080	-084	-088	-092	-096	10.000
		2.2595	2.7535	2.7510															
2 3/8	7GP1-3846-XXX	2.3835	2.8795	2.8750	2.3750	0.1442	-052	-056	-060	-064	-068	-072	-076	-080	-084	-088	-092	-096	10.000
		2.3845	2.8785	2.8760															
2 1/2	7GP1-4048-XXX	2.509	3.005	3.0000	2.5000	0.1511	-052	-056	-060	-064	-068	-072	-076	-080	-084	-088	-092	-096	10.000
		2.510	3.004	3.0015															
2 3/4	7GP1-4452-XXX	2.759	3.255	3.2500	2.7500	0.1648	-052	-056	-060	-064	-068	-072	-076	-080	-084	-088	-092	-096	10.000
		2.760	3.254	3.2515															
3	7GP1-4856-XXX	3.0080	3.5055	3.5000	3.0000	0.1790	-052	-056	-060	-064	-068	-072	-076	-080	-084	-088	-092	-096	10.000
		3.0105	3.5045	3.5020															
3 1/4	7GP1-5260-XXX	3.2580	3.7555	3.7500	3.2500	0.1928	-052	-056	-060	-064	-068	-072	-076	-080	-084	-088	-092	-096	10.000
		3.2605	3.7545	3.7520															
3 1/2	7GP1-5664-XXX	3.5080	4.0055	4.0000	3.5000	0.2066	-052	-056	-060	-064	-068	-072	-076	-080	-084	-088	-092	-096	10.000
		3.5105	4.0045	4.0020															
3 3/4	7GP1-6068-XXX	3.7580	4.2555	4.2500	3.7500	0.2203	-052	-056	-060	-064	-068	-072	-076	-080	-084	-088	-092	-096	10.000
		3.7605	4.2545	4.2520															
4	7GP1-6472-XXX	4.011	4.507	4.5000	4.0000	0.2334	-052	-056	-060	-064	-068	-072	-076	-080	-084	-088	-092	-096	10.000
		4.014	4.506	4.5020															
4 1/4	7GP1-6876-XXX	4.261	4.757	4.7500	4.2500	0.2459	-052	-056	-060	-064	-068	-072	-076	-080	-084	-088	-092	-096	10.000
		4.264	4.756	4.7520															
4 1/2	7GP1-7280-XXX	4.511	5.007	5.0000	4.5000	0.2596	-052	-056	-060	-064	-068	-072	-076	-080	-084	-088	-092	-096	10.000
		4.514	5.006	5.0020															
4 3/4	7GP1-7684-XXX	4.761	5.257	5.2500	4.7500	0.2732	-052	-056	-060	-064	-068	-072	-076	-080	-084	-088	-092	-096	10.000
		4.764	5.256	5.2520															
5	7GP1-8088-XXX	5.0105	5.507	5.5000	5.0000	0.2871	-052	-056	-060	-064	-068	-072	-076	-080	-084	-088	-092	-096	10.000
		5.0140	5.506	5.5020															

Standard MODEL SIZES are noted in BLACK. For MODEL SIZES in (BOLD) and shaded (Gray) consult with Rexnord Rex RPT Engineering.

1/4 Inch Wall Straight Sleeve Bearing (Continued)



Continued...

Bearing Dimensions

Bore Size	Part Number	ID	OD	Recommended Sizes			Model Number Suffix									Maximum Length
				Housing Bore	Max Shaft Dia	Wt (Ref) Lb/In.	L = Length Suffix in Multiples of 1/16" (Tolerance +/- .010)									
							6.500	7.000	7.500	8.000	8.500	9.000	9.500	10.000 +/- .025		
1/2	7GP1-0816-XXX	0.506	1.0035	1.0000	0.5000	0.0417										6.000
		0.507	1.0025	1.0005												
5/8	7GP1-1018-XXX	0.631	1.1285	1.1250	0.6250	0.0486	-104	-112	-120	-128	-136	-144	-152	-160	10.000	
		0.632	1.1275	1.1255												
3/4	7GP1-1220-XXX	0.756	1.2535	1.2500	0.7500	0.0555	-104	-112	-120	-128	-136	-144	-152	-160	10.000	
		0.757	1.2525	1.2505												
7/8	7GP1-1422-XXX	0.881	1.3785	1.3750	0.8750	0.0624	-104	-112	-120	-128	-136	-144	-152	-160	10.000	
		0.882	1.3775	1.3755												
1	7GP1-1624-XXX	1.006	1.5035	1.5000	1.0000	0.0693	-104	-112	-120	-128	-136	-144	-152	-160	10.000	
		1.007	1.5025	1.5005												
1 1/8	7GP1-1826-XXX	1.131	1.6285	1.6250	1.1250	0.0762	-104	-112	-120	-128	-136	-144	-152	-160	10.000	
		1.132	1.6275	1.6255												
1 1/4	7GP1-2028-XXX	1.256	1.7535	1.7500	1.2500	0.0831	-104	-112	-120	-128	-136	-144	-152	-160	10.000	
		1.257	1.7525	1.7505												
1 3/8	7GP1-2230-XXX	1.381	1.8785	1.8750	1.3750	0.0900	-104	-112	-120	-128	-136	-144	-152	-160	10.000	
		1.382	1.8775	1.8755												
1 1/2	7GP1-2432-XXX	1.506	2.0035	2.0000	1.5000	0.0970	-104	-112	-120	-128	-136	-144	-152	-160	10.000	
		1.507	2.0025	2.0005												
1 5/8	7GP1-2634-XXX	1.631	2.1285	2.1250	1.6250	0.1039	-104	-112	-120	-128	-136	-144	-152	-160	10.000	
		1.632	1.1275	2.1255												
1 3/4	7GP1-2836-XXX	1.757	2.2545	2.2500	1.7500	0.1108	-104	-112	-120	-128	-136	-144	-152	-160	10.000	
		1.758	2.2535	2.2510												
1 7/8	7GP1-3038-XXX	1.882	2.3795	2.3750	1.8750	0.1177	-104	-112	-120	-128	-136	-144	-152	-160	10.000	
		1.883	2.3785	2.3760												
2	7GP1-3240-XXX	2.0085	2.5045	2.5000	2.0000	0.1243	-104	-112	-120	-128	-136	-144	-152	-160	10.000	
		2.0095	2.5035	2.5010												
2 1/8	7GP1-3442-XXX	2.1335	2.6295	2.6250	2.1250	0.1306	-104	-112	-120	-128	-136	-144	-152	-160	10.000	
		2.1345	2.6285	2.6260												
2 1/4	7GP1-3644-XXX	2.2585	2.7545	2.7500	2.2500	0.1374	-104	-112	-120	-128	-136	-144	-152	-160	10.000	
		2.2595	2.7535	2.7510												
2 3/8	7GP1-3846-XXX	2.3835	2.8795	2.8750	2.3750	0.1442	-104	-112	-120	-128	-136	-144	-152	-160	10.000	
		2.3845	2.8785	2.8760												
2 1/2	7GP1-4048-XXX	2.509	3.005	3.0000	2.5000	0.1511	-104	-112	-120	-128	-136	-144	-152	-160	10.000	
		2.510	3.004	3.0015												
2 3/4	7GP1-4452-XXX	2.759	3.255	3.2500	2.7500	0.1648	-104	-112	-120	-128	-136	-144	-152	-160	10.000	
		2.760	3.254	3.2515												
3	7GP1-4856-XXX	3.0080	3.5055	3.5000	3.0000	0.1790	-104	-112	-120	-128	-136	-144	-152	-160	10.000	
		3.0105	3.5045	3.5020												
3 1/4	7GP1-5260-XXX	3.2580	3.3755	3.7500	3.2500	0.1928	-104	-112	-120	-128	-136	-144	-152	-160	10.000	
		3.2605	3.3745	3.7520												
3 1/2	7GP1-5664-XXX	3.5080	4.0055	4.0000	3.5000	0.2066	-104	-112	-120	-128	-136	-144	-152	-160	10.000	
		3.5105	4.0045	4.0020												
3 3/4	7GP1-6068-XXX	3.7580	4.2555	4.2500	3.7500	0.2203	-104	-112	-120	-128	-136	-144	-152	-160	10.000	
		3.7605	4.2545	4.2520												
4	7GP1-6472-XXX	4.011	4.507	4.5000	4.0000	0.2334	-104	-112	-120	-128	-136	-144	-152	-160	10.000	
		4.014	4.506	4.5020												
4 1/4	7GP1-6876-XXX	4.261	4.757	4.7500	4.2500	0.2459	-104	-112	-120	-128	-136	-144	-152	-160	10.000	
		4.264	4.756	4.7520												
4 1/2	7GP1-7280-XXX	4.511	5.007	5.0000	4.5000	0.2596	-104	-112	-120	-128	-136	-144	-152	-160	10.000	
		4.514	5.006	5.0020												
4 3/4	7GP1-7684-XXX	4.761	5.257	5.2500	4.7500	0.2732	-104	-112	-120	-128	-136	-144	-152	-160	10.000	
		4.764	5.256	5.2520												
5	7GP1-8088-XXX	5.0105	5.507	5.5000	5.0000	0.2871	-104	-112	-120	-128	-136	-144	-152	-160	10.000	
		5.0140	5.506	5.5020												

Standard MODEL SIZES are noted in BLACK. For MODEL SIZES in (BOLD) and shaded (Gray) consult with Rexnord Rex RPT Engineering.

Filament Bearings Custom: Duralon



Contents

	Page
Features and Benefits	514
Nomenclature	515
Engineering	516
Dimensions	
Sleeve	517
Annular	524
Flange	525
Thrust Washers	526
Annular	527
Mounting	528

Industries Served

Construction
Agriculture
Food
Marine



Filament Bearings

Rexnord Duralon Filament Bearings are a self-lubricated bearing, normally used between 4,000 and 30,000 psi in sliding and oscillating linkages. It is constructed from woven Teflon[™] high strength fiber and bondable yarns to make up the bearing element. Continuous strands of fiberglass and epoxy resin make up the matrix of the composite bearing material.

Features and Benefits

Strength

Applications that have 30,000 psi dynamically
Optimizes strength/weight ratio

Corrosion Resistance

Resists galvanic and fretting corrosion

Self-Lubricating

Eliminates contaminating lubricants
Operates above or below useful
temperature of lubricants
Eliminates complex lubrication systems
Minimizes slipstick problems

Seizure Resistance

Minimizes galling and scoring

Lightweight

77% of steel weight, 30% of aluminum –
easier handling, reduces equipment weight

Non-Metallic

Electrical insulation
Reduces noise volumes
USDA approved for non-contact use



Sizes and Shapes Available

Straight Sleeve Bearings

Round, Square and Hex Bore
Round Bore Diameter – 1/8" to 26"
PTFE fabric on ID bore and optional on OD

Linear Bearings

Bore Diameter – 1/4" to 4"
Available in open configuration to
clear pedestal shaft mounts

Flange Bearings

Bore Diameter – 1/8" to 26"
Available with or without woven
PTFE liner on the flange face

Thrust Washers

Outer Diameter – 3/8" to 18"

Spherical Annular

Bore Diameter – 1/4" to 6"

Actuator Bearing

Bore Diameter – consult Rexnord Engineering
Bore Shapes – Helical and threaded



▼ Teflon[™] is a trademark of The Chemours Company FC, LLC used under license by Toray Fluorofibers (America), Inc.

Nomenclature

Symbol	Description	
701	Straight Sleeve Bearing	<div style="text-align: right; font-weight: bold; font-size: 1.2em;">7010 - 000 008 - 016</div>
702	Flange Sleeve, No PTFE Fabric on the Flange Face	
703	Flange Sleeve, PTFE Fabric on the Flange Face	
706	Actuator Nut	
707	Thrust Washer, PTFE Fabric on one face or both	
708	OD lined Sleeve Bearing, Cylindrical O.D.	
710	Ball Bearing Replacement, Cylindrical O.D.	
711	Ball Bearing Replacement, Spherical O.D., without Fabric on the O.D.	
718	Ball Bearing Replacement, Spherical O.D., PTFE Fabric on the O.D.	
799	Special Bearing Configuration	
00	Catalog Thinwall Bearing	
01	Catalog Heavywall Bearing	
61	Open Linear Replacement Bearing	
66	Catalog Linear Replacement Bearing	
70	Catalog Square Bore Bearing	
90	Catalog Hex Bore Bearing	
008	Bore Size (1 inch = 016)	
016	Bearing Length The length of the bearing in 1/32 of an inch increments	

Design and Application Guidelines

The overall performance of filament wound bearings is directly affected by operating factors such as applied loads, operating motions, duty cycle, environmental conditions, installation methods, shaft finish and hardness. While specific design criteria are not available for all applications, certain guidelines must be followed to provide the rated life.

Loads and Ratings

The filament wound back-up material in Duralon journal bearings is capable of withstanding static radial load levels as high as 60,000 psi on the projected bearing area. This is in excess of the fabric liner capability of (50,000 psi) based on previous experiences. The load deflection relationship of Duralon journal bearings and metal-backed Teflon[™] lined bearings is very similar. The yield point and ultimate strength of the filament wound back-up material are approximately equal.

$$\text{PSI} = \frac{\text{Load lbs.}}{\text{I.D.} \times \text{W}}$$

Load-life Relationship

Since accumulated wear terminates the useful life of a properly selected Teflon[™] liner bearing, the Duralon selection procedure is based on the use of Bearing Area Factors (BAF), rather than load ratings, to select a bearing which meets the combined load-life requirements of the application. The Bearing Area Factor (BAF) is a numerical index of a bearing's dynamic performance ability and is based upon effective bearing area.

Duralon bearings are rated on the basis of L10 life expectancy which means that 90% of a given group of bearings will exceed the predicted life. The correlation of load and life is shown in the lower half of the Selection Chart which relates the BAF to cycle of life. BAF values for bearings involving standard combinations of bore and length, are shown in the bearing listings.

Bearing Area Factor

$$\text{BAF} = \text{I.D.}^{0.491} \times (\text{W} - .090)$$

I.D. = Bearing Inner Diameter

W = Bearing Length

All dimensions are in inches

Motion

Duralon bearings can withstand various degrees of motion, depending upon speed and load. They will operate under all degrees of motion normally encountered in applications. Note that the degree of oscillation can affect bearing performance and must be taken into account when making a bearing selection, as shown on the nomograph.

Laboratory testing of Filament journal bearings has shown their capacity to operate successfully under the low speeds, (less than 90 cycles per minute), high load conditions, (up to 30,000 psi), as well as the high speeds (up to 300 cpm), light load (less than 5,000 psi) conditions.

Temperature

The normal operating temperature range for Duralon bearings is -65° to 325° F. Satisfactory operation can be obtained with limited exposure to temperatures as high as 400° F. However, at continuous temperatures above 325° F an increase in wear rates will be experienced. Contact a Rexnord engineer for applications at cryogenic temperature, as well as for applications.

Shaft Recommendations

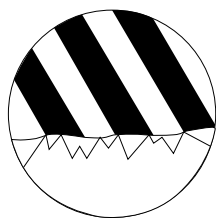
Since the shaft surface significantly affects the operation of the journal bearing design, its selection in regard to material, hardness, coating and surface roughness is crucial.

High loads require smooth surfaces with hardened and heat treated shafts. With stress levels of 8,000 to 30,000 psi shafting should have a surface finish of 8 micro inch or better to achieve optimum performance. However, tests have been run on 25-30 micro inch finishes with 55 Rc shafts at 4,000 psi with acceptable results.

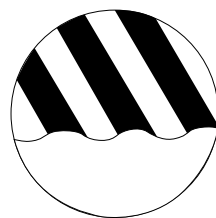
Shafting Materials

A number of shaft materials have been used in conjunction with Duralon bearings:

1. 52100 high carbon steel
2. 4140 chrome and nickel plated steel
3. 300 and 400 series stainless steel
4. Precipitation hardened grades 17-4PH, 15-5PH, 13-8PH
Moly chrome and nickel plated stainless steel
5. 2000 and 7000 series aluminum grade hard-anodized
6. Low to high carbon steels



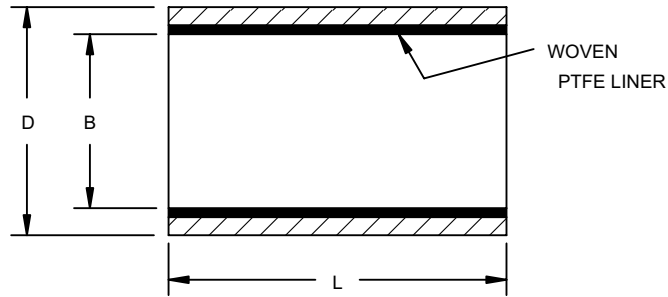
Sharp surface scratches



Smooth surface scratches

Surface roughness values do not define the character of the finish. Polished shafting (right) normally produces longer bearing life.

Thinwall Straight Sleeve Bearing



Product Features

The bearing consists of a self-lubricating woven Teflon ▼ fiber and polyester liner supported by a filament wound continuous fiberglass fiber and epoxy resin matrix.

Bearing Dimensions

Part Number	Thinwall					Model Number Suffix										Maximum Length		
	B ±.0005	D ±.0005	Hsg Bore ±.0005	Max Shaft Dia	Wt (Ref) Lb/In.	L= Length Suffix in Multiples of 1/32" (Tolerance +.000/-0.020)												
	0.250	0.375	0.500	0.625	0.750	0.875	1.000	1.125	1.250	1.375	1.500	1.750	2.000					
701-00004-XXX	0.2535	0.3762	0.3750	0.2500	0.0043													3.000
701-00006-XXX	0.3785	0.5012	0.5000	0.3750	0.0060	008						040	044					6.000
701-00008-XXX	0.5035	0.6262	0.6250	0.5000	0.0077		012							048				6.000
701-00010-XXX	0.6285	0.7512	0.7500	0.6250	0.0094			016							056	064		10.000
701-00012-XXX	0.7535	0.8762	0.8750	0.7500	0.0111				020									10.000
701-00014-XXX	0.8785	1.0637	1.0625	0.8750	0.0199					024								10.000
701-00016-XXX	1.0035	1.1887	1.1875	1.0000	0.0224						028							10.000
701-00018-XXX	1.1285	1.3137	1.3125	1.1250	0.0250							032						10.000
701-00020-XXX	1.2535	1.4387	1.4375	1.2500	0.0276								036					10.000
701-00022-XXX	1.3785	1.5637	1.5625	1.3750	0.0301													10.000
701-00024-XXX	1.5035	1.6887	1.6775	1.5000	0.0325													10.000
701-00026-XXX	1.6285	1.8137	1.8125	1.6250	0.0352	008						040	044					10.000
701-00028-XXX	1.7535	1.9387	1.9375	1.7500	0.0378		012							048				10.000
701-00030-XXX	1.8785	2.0637	2.0625	1.8750	0.0404			016							056	064		10.000
701-00032-XXX	2.0035	2.1887	2.1875	2.0000	0.0429				020									10.000
701-00034-XXX	2.1285	2.3137	2.3125	2.1250	0.0455					024								10.000
701-00036-XXX	2.2535	2.4387	2.4375	2.2500	0.0480						028							10.000
701-00040-XXX	2.5035	2.6887	2.6875	2.5000	0.0532							032						10.000
701-00044-XXX	2.7545	2.9487	2.9475	2.7500	0.0612								036					10.000

Additional Notes

- Size:** Standard & Metric sizes - from .250" to 2.750" inside diameter
- Load:** Typical dynamic loads - 4,000 to 30,000 psi, Ultimate 77,000 psi
- Motion:** Oscillatory, pivot, linear sliding and slow speed full rotation
- Friction:** Coefficients vary from .16 @ 500 psi to .07 @ 20,000 psi
- Electrical:** Filament wound back-up material is an electrical insulator
- Chemical:** Resistant to most chemicals, see Appendix or consult Rexnord engineer
- Temperature:** -65°F to +325°F for Continuous, 400°F for Intermittent

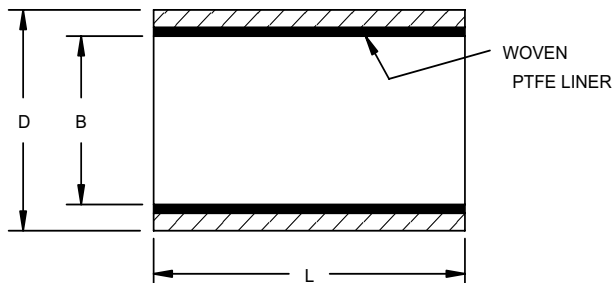
For part number sizes shaded in gray please consult Rexnord Bearing Engineering

Thinwall Straight Sleeve Bearing (Inch)



Product Features

The bearing consists of a self-lubricating woven Teflon™ fiber and polyester liner supported by a filament wound continuous fiberglass fiber and epoxy resin matrix.



Bearing Dimensions

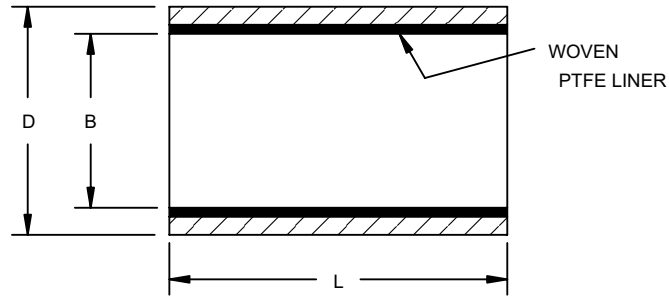
Thinwall - Metric					Model Number Suffix									
Part Number	B ±.0005	D ±.0005	Hsg Bore ±.0003	Max Shaft Dia	L= Length Suffix in Multiples of 1mm (Tolerance +.000/- .500)									
					0.250	0.375	0.500	0.625	0.750	0.875	1.000	1.125	1.250	1.375
7MM1-02006-XXX	0.2397	0.3163	0.3153	0.2358	010	020	030	040	050	060	070	080	090	100
7MM1-03006-XXX	0.2397	0.3556	0.3546	0.2358										
7MM1-02008-XXX	0.3185	0.3950	0.3940	0.3144										
7MM1-03008-XXX	0.3185	0.4344	0.4334	0.3144										
7MM1-02010-XXX	0.3972	0.4738	0.4727	0.3932										
7MM1-03010-XXX	0.3972	0.5132	0.5121	0.3932										
7MM1-02012-XXX	0.4759	0.5526	0.5515	0.4718										
7MM1-03012-XXX	0.4759	0.592	0.5909	0.4718										
7MM1-02014-XXX	0.5547	0.6313	0.6302	0.5506										
7MM1-03014-XXX	0.5547	0.7101	0.7090	0.5506										
7MM1-02016-XXX	0.6334	0.7101	0.7090	0.6293										
7MM1-03016-XXX	0.6334	0.7889	0.7878	0.6293										
7MM1-02018-XXX	0.7122	0.7889	0.7878	0.7080										
7MM1-03018-XXX	0.7122	0.8677	0.8665	0.7080										
7MM1-02020-XXX	0.7909	0.9070	0.9059	0.7866										
7MM1-03020-XXX	0.7909	0.9464	0.9453	0.7866										
7MM1-02022-XXX	0.8696	0.9858	0.9846	0.8654										
7MM1-03022-XXX	0.8696	1.0645	1.0634	0.8654										
7MM1-02025-XXX	0.9877	1.1039	1.1028	0.9835										
7MM1-03025-XXX	0.9877	1.1826	1.1815	0.9835										
7MM1-02030-XXX	1.1846	1.3403	1.3391	1.1803										
7MM1-03030-XXX	1.1846	1.3795	1.3784	1.1803										
7MM1-02040-XXX	1.5783	1.7340	1.7328	1.5738										
7MM1-03040-XXX	1.5783	1.8127	1.8115	1.5738										
7MM1-02045-XXX	1.7751	1.9702	1.9690	1.7707										
7MM1-03045-XXX	1.7751	2.0096	2.0084	1.7707										
7MM1-02050-XXX	1.9720	2.1672	2.1659	1.9675										
7MM1-03050-XXX	1.9720	2.2851	2.2839	1.9675										

Additional Notes

- Size:** Metric sizes - from 1/8" to 26" inside diameter
- Load:** Typical dynamic loads - 4,000 to 30,000 psi, Ultimate 77,000 psi
- Motion:** Oscillatory, pivot, linear sliding and slow speed full rotation
- Friction:** Coefficients vary from .16 @ 500 psi to .07 @ 20,000 psi
- Electrical:** Filament wound back-up material is an electrical insulator
- Chemical:** Resistant to most chemicals, see Appendix or consult Rexnord engineer
- Temperature:** -65°F to +325°F for Continuous, 400°F for Intermittent

For part number sizes shaded in gray please consult Rexnord Bearing Engineering

Thinwall Straight Sleeve Bearing (Metric)



Product Features

The bearing consists of a self-lubricating woven Teflon[®] fiber and polyester liner supported by a filament wound continuous fiberglass fiber and epoxy resin matrix.

Bearing Dimensions

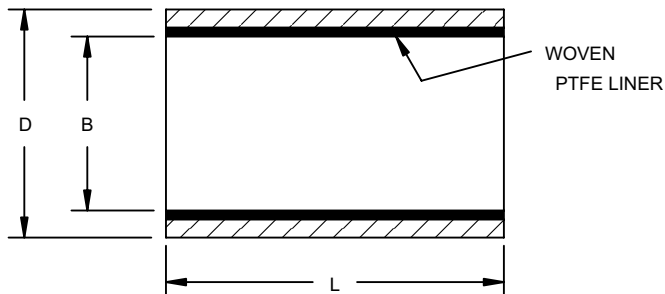
Thinwall - Metric							Model Number Suffix																
Part Number	B	Tolerance	D	Tolerance	Max Hsg Bore	Max Shaft Dia	L= Length Suffix in Multiples of 1mm (Tolerance +.000/- .500)																
							10	20	30	40	50	60	70	80	90	100							
7MM1-02006-XXX	6,0855	,0125	8,034	,013	,8000	5,978																	
7MM1-03006-XXX	6,0855	,0125	9,032	,012	,9000	5,978															080	090	100
7MM1-02008-XXX	8,0900	,0130	10,033	,013	,10000	7,972																	
7MM1-03008-XXX	8,0900	,0130	11,033	,012	,11000	7,972																	
7MM1-02010-XXX	10,0890	,0130	12,034	,012	,12000	9,972																	
7MM1-03010-XXX	10,0890	,0130	13,035	,012	,13000	9,972																	
7MM1-02012-XXX	12,0880	,0130	14,036	,013	,14000	11,966																	
7MM1-03012-XXX	12,0880	,0130	15,037	,013	,15000	11,966																	
7MM1-02014-XXX	14,0895	,0125	16,035	,013	,16000	13,966																	
7MM1-03014-XXX	14,0895	,0125	18,036	,012	,18000	15,966																	
7MM1-02016-XXX	16,0885	,0125	18,036	,012	,18000	15,966	010																
7MM1-03016-XXX	16,0885	,0125	20,038	,013	,20000	15,966																	
7MM1-02018-XXX	18,0900	,0130	20,038	,013	,20000	17,966		020															
7MM1-03018-XXX	18,0900	,0130	22,039	,012	,22000	17,966																	
7MM1-02020-XXX	20,0890	,0130	23,038	,013	,23000	19,959																	
7MM1-03020-XXX	20,0890	,0130	23,038	,012	,24000	19,959				030	040	050	060	070							080	090	100
7MM1-02022-XXX	22,0880	,0130	25,039	,012	,25000	21,959																	
7MM1-03022-XXX	22,0880	,0130	27,038	,012	,27000	21,959																	
7MM1-02025-XXX	25,0875	,0125	28,039	,013	,28000	24,959																	
7MM1-03025-XXX	25,0875	,0125	30,038	,013	,30000	24,959																	
7MM1-02030-XXX	30,0890	,0130	34,043	,013	,34000	29,959																	
7MM1-03030-XXX	30,0890	,0130	35,039	,012	,35000	29,959																	
7MM1-02040-XXX	40,0890	,0130	44,043	,013	,44000	39,950																	
7MM1-03040-XXX	40,0890	,0130	46,043	,012	,46000	39,950																	
7MM1-02045-XXX	45,0875	,0125	50,043	,013	,50000	44,950																	
7MM1-03045-XXX	45,0875	,0125	51,044	,013	,51000	44,950																	
7MM1-02050-XXX	50,0890	,0130	55,047	,013	,55000	49,950																	
7MM1-03050-XXX	50,0890	,0130	58,041	,012	,58000	49,950																	

Additional Notes

- Size:** Metric sizes - from 4mm to 660mm
- Load:** Typical dynamic loads - 4,000 to 30,000 psi, Ultimate 77,000 psi
- Motion:** Oscillatory, pivot, linear sliding and slow speed full rotation
- Friction:** Coefficients vary from .16 @ 500 psi to .07 @ 20,000 psi
- Electrical:** Filament wound back-up material is an electrical insulator
- Chemical:** Resistant to most chemicals, see Appendix or consult Rexnord engineer
- Temperature:** -65°F to +325°F for Continuous, 400°F for Intermittent

For part number sizes shaded in gray please consult Rexnord Bearing Engineering

Heavywall Straight Sleeve Bearing



Product Features

The bearing consists of a self-lubricating woven Teflon™ fiber and polyester liner supported by a filament wound continuous fiberglass fiber and epoxy resin matrix.

Bearing Dimensions

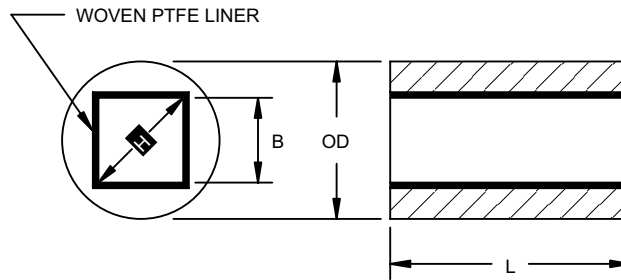
Part Number	B	Tolerance	D	Tolerance	Housing Bore	Tolerance	Max Shaft Dia	Wt (Ref) Lb/in.	Model Number Suffix										
									L= Length Suffix in Multiples of 1/32" (Tolerance +.000/- .020)										
									1.000	1.250	1.500	1.750	2.000	2.500	3.000	3.500	4.000	6.000	10.000
701-01028-XXX	1.7590	±.0010	2.2505	±.0005	2.2470	±.001	1.7500	0.1086	032	040	048	056	064	080	096	112	128	192	320
701-01032-XXX	2.0090		2.5005		2.4970		2.0000	0.1222											
701-01036-XXX	2.2590		2.7505		2.7470		2.2500	0.1357											
701-01040-XXX	2.5090	3.0005	2.9970	2.5000	0.1493														
701-01044-XXX	2.7590	3.2505	3.2470	2.7500	0.1628														
701-01048-XXX	3.0097	3.5005	3.4970	3.0000	0.1762														
701-01052-XXX	3.2597	+0.0013	3.7505	3.7470	3.2500	0.1898													
701-01056-XXX	3.5097	-0.0012	4.0005	3.9970	3.5000	0.2033													
701-01060-XXX	3.7597	4.2505	4.2470	3.7500	0.2169														
701-01064-XXX	4.0105	4.5005	4.4970	4.0000	0.2302														
701-01068-XXX	4.2605	±.0015	4.7505	4.7470	4.2500	0.2437													
701-01072-XXX	4.5125		5.0005	4.9970	4.5000	0.2562													
701-01076-XXX	4.7615		5.2505	5.2470	4.7500	0.2702													
701-01080-XXX	5.0112	+0.0018	5.5005	5.4970	5.0000	0.2840													
701-01084-XXX	5.2612		5.7505	5.7470	5.2500	0.2975													
701-01088-XXX	5.5142		6.0008	5.9960	5.5000	0.3095													
701-01092-XXX	5.7642	6.2508	6.2460	5.7500	0.3230														
701-01096-XXX	6.0140	6.5008	6.4960	6.0000	0.3367														
701-01100-XXX	6.2640	±.0020	6.7508	6.7460	6.2500	0.3502													
701-01104-XXX	6.5140		7.0008	6.9955	6.5000	0.3636													
701-01108-XXX	6.7640		7.2508	7.2455	6.7500	0.3771													
701-01112-XXX	7.0137	+0.0023	7.5008	7.4955	7.0000	0.3910													
701-01120-XXX	7.5137	-0.0022	8.0008	7.9955	7.5000	0.4179													
701-01128-XXX	8.0135	8.2508	8.4955	8.0000	0.4453														
701-01136-XXX	8.5135	9.0010	8.9955	8.5000	0.4727														
701-01144-XXX	9.0135	±.0025	9.5010	9.4955	9.0000	0.4997													
701-01152-XXX	9.5135		10.0010	9.9955	9.5000	0.5267													
701-01160-XXX	10.0135		10.5010	10.4955	10.0000	0.5537													
701-01168-XXX	10.5135	±.0010	11.0010	10.9955	10.5000														
701-01176-XXX	11.0135		11.5010	11.4955	11.0000														
701-01184-XXX	11.5135		12.0010	11.9955	11.5000														
701-01192-XXX	12.0135		12.5010	12.4955	12.0000														

Additional Notes

- Size:** Standard & Metric sizes - from 1.750" to 12.000" inside diameter
- Load:** Typical dynamic loads - 4,000 to 30,000 psi, Ultimate 77,000 psi
- Motion:** Oscillatory, pivot, linear sliding and slow speed full rotation
- Friction:** Coefficients vary from .16 @ 500 psi to .07 @ 20,000 psi
- Electrical:** Filament wound back-up material is an electrical insulator
- Chemical:** Resistant to most chemicals, see Appendix or consult Rexnord engineer
- Temperature:** -65°F to +325°F for Continuous, 400°F for Intermittent

For part number sizes shaded in gray please consult Rexnord Bearing Engineering

Square Bore Bearing



Bearing Dimensions

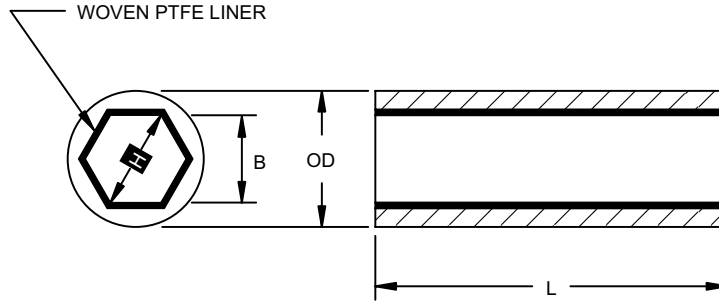
Part Number	Square Bore			Model Number Suffix												Maximum Length		
	B ±.001	D ±.0005	H Min	L= Length Suffix in Multiples of 1/32" (Tolerance +.000/-0.020)														
				0.250	0.375	0.500	0.625	0.750	0.875	1.000	1.125	1.250	1.375	1.500	1.750		2.000	
701-70004-XXX	0.254	0.5012	0.313															3.000
701-70006-XXX	0.379	0.7512	0.490	008								040	044					6.000
701-70008-XXX	0.504	0.8762	0.667		012									048	056	064		6.000
701-70010-XXX	0.629	1.0012	0.843			016												10.000
701-70012-XXX	0.754	1.2512	1.020				020											10.000
701-70014-XXX	0.879	1.5012	1.197					024	028	032	036							10.000
701-70016-XXX	1.004	1.6262	1.374	008								040	044					10.000
701-70018-XXX	1.129	1.8762	1.551											048				10.000
701-70020-XXX	1.254	2.0012	1.727		012										056	064		10.000
701-70022-XXX	1.379	2.2512	1.904			016												10.000
701-70024-XXX	1.504	2.5012	2.081				020											10.000

Additional Notes

- Size:** Standard sizes - from .250" to 1.500" inside diameter, larger sizes available
- Load:** Typical dynamic loads - 4,000 to 30,000 psi, Ultimate 77,000 psi
- Motion:** Linear sliding and/or torque transmission
- Friction:** Coefficients vary from .16 @ 500 psi to .07 @ 20,000 psi
- Electrical:** Filament wound back-up material is an electrical insulator
- Chemical:** Resistant to most chemicals, see Appendix or consult Rexnord engineer
- Temperature:** -65°F to +325°F for Continuous, 400°F for Intermittent

For part number sizes shaded in gray please consult Rexnord Bearing Engineering

Hex Bore Bearing



Product Features

The bearing consists of a self-lubricating woven Teflon™ fiber and polyester liner supported by a filament wound continuous fiberglass fiber and epoxy resin matrix.

Bearing Dimensions

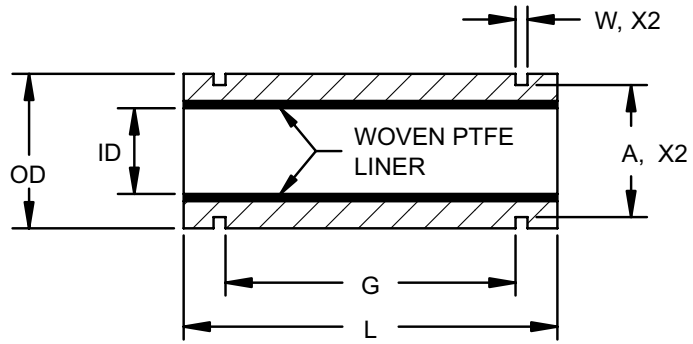
Hex Bore					Model Number Suffix												Maximum Length	
Part Number	B	Tolerance	OD ± .0005	H Min.	L= Length Suffix in Multiples of 1/32" (Tolerance +.000/-.020)													
					0.250	0.375	0.500	0.625	0.750	0.875	1.000	1.125	1.250	1.375	1.500	1.750		2.000
701-90004-XXX	0.255	±.001	0.5012	0.248	008	012	016	020	024	028	032	036	040	044	048	056	064	3.000
701-90006-XXX	0.380		0.6262	0.392														6.000
701-90008-XXX	0.505		0.7512	0.537														6.000
701-90010-XXX	0.630		0.8762	0.681														10.000
701-90012-XXX	0.755		1.0012	0.825														10.000
701-90014-XXX	0.880		1.2512	0.970														10.000
701-90016-XXX	1.005		1.5004	1.114														10.000
701-90018-XXX	1.130	±.002	1.6262	1.259	008	012	016	020	024	028	032	036	040	044	048	056	064	10.000
701-90020-XXX	1.255		1.7512	1.403														10.000
701-90022-XXX	1.380		1.8762	1.547														10.000
701-90024-XXX	1.505		2.0012	1.692														10.000
																		10.000

Additional Notes

- Size:** Standard sizes - from .250" to 1.500" inside diameter
- Load:** Typical dynamic loads - 4,000 to 30,000 psi, Ultimate 77,000 psi
- Motion:** Linear sliding and/or torque transmission
- Friction:** Coefficients vary from .16 @ 500 psi to .07 @ 20,000 psi
- Electrical:** Filament wound back-up material is an electrical insulator
- Chemical:** Resistant to most chemicals, see Appendix or consult Rexnord engineer
- Temperature:** -65°F to +325°F for Continuous, 400°F for Intermittent

For part number sizes shaded in gray please consult Rexnord Bearing Engineering

Linear Composite Bearings



Product Features

The bearing consists of a self-lubricating woven Teflon™ fiber and polyester liner supported by a filament wound continuous fiberglass fiber and epoxy resin matrix. Open Linear bearings for pedestal shaft mounts available.

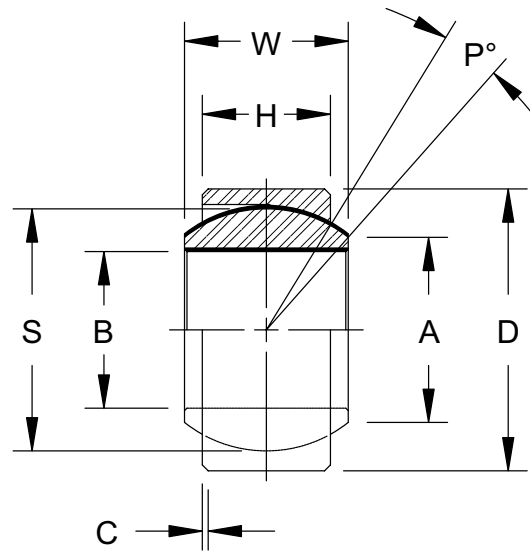
Bearing Dimensions

Part Number	I.D.	Tolerance	OD ±.0005	L +.000 -.020	G	Tolerance	Snap Ring Groove				O.D to I.D. Concentricity
							W	Tolerance	A	Tolerance	
701-66004-024	0.2510	±.0005	0.5006	0.750	0.437	±.010	0.0405	±.0015	0.468	±.002	.001 TIR
701-66006-028	0.3760		0.6256	0.875	0.562		0.0405		0.588	±.003	
701-66008-040	0.5010		0.8756	1.250	0.875		0.0475	0.821	±.004		
701-66010-048	0.6260		1.1256	1.500	1.000		0.0580	1.059			
701-66012-052	0.7510		1.2506	1.625	1.062	0.0580	1.176	±.005			
701-66016-072	1.0010		1.5631	2.250	1.625	0.0700	1.468				
701-66020-084	1.2510		2.0006	2.625	1.875	0.0700	1.886	±.006			
701-66024-096	1.5010		2.3756	3.000	2.250	0.0885	2.239				
701-66032-128	2.0010		3.0006	4.000	3.000	0.1055	2.838	±.006			
701-60040-160	2.5055		3.7506	5.000	3.750	0.1225	3.493				
701-60048-192	3.0060	±.0010	4.5006	6.000	4.500	0.1225	4.190	±.006			
701-60064-256	4.0065	±.0015	6.0006	8.000	6.000	±.020	0.1420		±.0030	5.745	.003 TIR

Additional Notes

- Size:** Standard sizes - from .250" to 4.000" inside diameter
- Load:** Typical dynamic loads - 4,000 to 30,000 psi, Ultimate 77,000 psi
- Motion:** Oscillatory, pivot, linear sliding and slow speed full rotation
- Friction:** Coefficients vary from .16 @ 500 psi to .07 @ 20,000 psi
- Electrical:** Filament wound back-up material is an electrical insulator
- Chemical:** Resistant to most chemicals, see Appendix or consult Rexnord engineer
- Temperature:** -65°F to +325°F for Continuous, 400°F for Intermittent

Split Metallic Outer Race Annular Bearings



Product Features

The self-lubricating composite ball consists of a woven Teflon™ fiber and polyester fiber liner supported by a filament wound continuous fiberglass fiber and epoxy resin matrix. The split metallic outer race is carbon steel.

Bearing Dimensions

Part Number	Part Number	B Min	Tolerance	D Max	Tolerance	W +.000 -.005	H +.000 -.005	A (Ref)	C +.010 -.010	P Deg. Min	S Ball O.D.	Limit Load Rating- Lbs.	
831-08-14-01	838-08-14-01	0.5030	+.001	0.8750	+.000 -.0005	0.437	0.375	0.571	0.022	6	0.719	3,750	
831-12-20-01	838-12-20-01	0.7530		1.2500		0.656	0.562	0.858			1.080	8,430	
831-14-23-01	838-14-23-01	0.8780		1.4375		0.765	0.656	0.999			1.258	11,480	
831-16-26-01	838-16-26-01	1.0030		1.6250		0.875	0.750	1.140			1.437	15,000	
831-20-32-01	838-20-32-01	1.2530		2.0000	1.093	0.937	1.424	1.795			23,425		
831-22-35-01	838-22-35-01	1.3780		2.1875	1.187	1.031	1.531	1.937			28,350		
831-24-39-01	838-24-39-01	1.5030		2.4375	1.312	1.125	1.710	2.155			33,750		
831-28-45-01	838-28-45-01	1.7530		2.8125	1.531	1.312	1.995	2.515			45,925		
831-32-51-01	838-32-51-01	2.0030		3.1875	1.750	1.500	2.281	2.875			60,000		
831-36-57-01	838-36-57-01	2.2530		3.5625	1.969	1.687	2.567	3.235			75,900		
831-40-63-01	838-40-63-01	2.5030		3.9375	2.187	1.875	2.847	3.590			93,750		
831-48-76-01	838-48-76-01	3.0030		4.7500	2.625	2.250	3.421	4.312			135,000		
831-64-100-01	838-64-100-01	4.0030		+0.003	6.2500	+0.010	3.500	3.000			4.562	5.750	240,000
831-80-124-01	838-80-124-01	5.0020		+0.005	7.7500	+.0022	4.375	3.750			5.706	7.190	375,000
831-96-140-01	838-96-140-01	6.0030	+0.004	8.7500	4.750		4.125	6.630	5	8.156	495,000		

Additional Notes

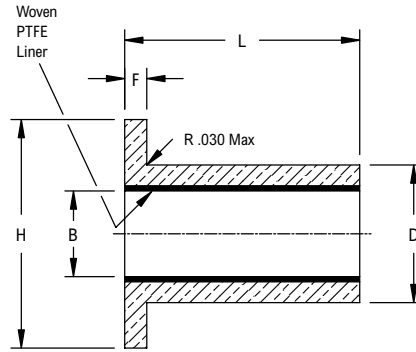
- Size:** Standard & Metric sizes - from .500" to 6.000" inside diameter
- Load:** Typical dynamic loads - 4,000 to 20,000 psi
- Motion:** Oscillatory, pivot, slow speed full rotation, for linear consult Rexnord engineer
- Friction:** Coefficients vary from .16 @ 500 psi to .07 @ 20,000 psi
- Electrical:** Filament wound back-up material of the ball is an electrical insulator
- Chemical:** Consult Rexnord engineer
- Temperature:** -65°F to +325°F for Continuous, 400°F for Intermittent

Flange Bearings

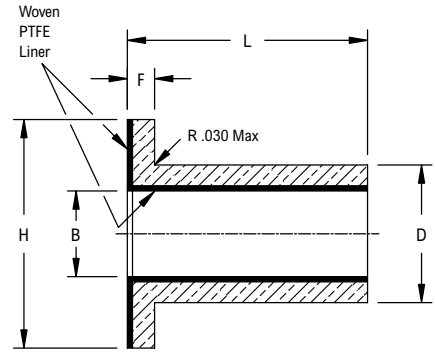


Product Features

The bearing consists of a self-lubricating woven Teflon[®] fiber and polyester liner supported by a filament wound continuous fiberglass fiber and epoxy resin matrix.



STYLE-702



STYLE-703

Bearing Dimensions

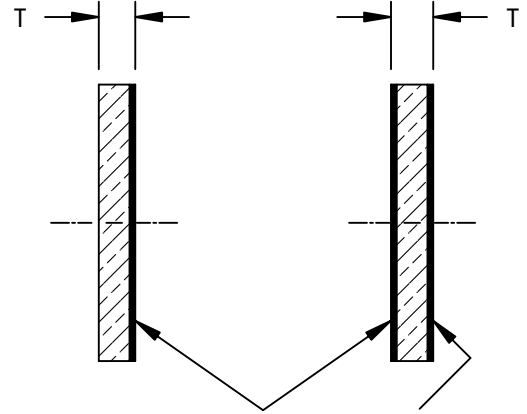
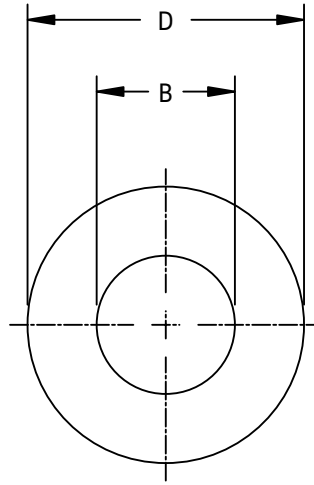
Part Number		B ± .0005	D ± .0005	F ± .005	H ± .010	Model Number Suffix																		
Unlined Face	Lined Face					L = Length Suffix in Multiples of 1/32" (Tolerance + .000 / - .020)																		
												0.250	0.375	0.500	0.625	0.750	0.875	1.000	1.125	1.250	1.375	1.500	1.750	2.000
702-00004-XXX	703-00004-XXX	0.2535	0.3762	0.094	0.625	008	012	016	020	024	028	032	036	040	044	048	056	064						
702-00006-XXX	703-00006-XXX	0.3785	0.5012	0.125	0.750																			
702-00008-XXX	703-00008-XXX	0.5035	0.6262	0.125	0.875																			
702-00010-XXX	703-00010-XXX	0.6285	0.7512	0.125	1.000																			
702-00012-XXX	703-00012-XXX	0.7535	0.8762	0.125	1.125																			
702-00014-XXX	703-00014-XXX	0.8785	1.0637	0.125	1.312																			
702-00016-XXX	703-00016-XXX	1.0035	1.1887	0.156	1.438																			
702-00018-XXX	703-00018-XXX	1.1285	1.3137	0.156	1.562																			
702-00020-XXX	703-00020-XXX	1.2535	1.4387	0.156	1.688																			
702-00022-XXX	703-00022-XXX	1.3785	1.5637	0.156	1.812																			
702-00024-XXX	703-00024-XXX	1.5035	1.6887	0.156	1.938																			
702-00026-XXX	703-00026-XXX	1.6285	1.8137	0.156	2.062																			
702-00028-XXX	703-00028-XXX	1.7535	1.9387	0.188	2.188																			
702-00030-XXX	703-00030-XXX	1.8785	2.0637	0.188	2.312																			
702-00032-XXX	703-00032-XXX	2.0035	2.1887	0.188	2.438																			
702-00034-XXX	703-00034-XXX	2.1285	2.3137	0.188	2.562																			
702-00036-XXX	703-00036-XXX	2.2535	2.4387	0.188	2.688																			
702-00040-XXX	703-00040-XXX	2.5035	2.6887	0.188	2.938																			

Additional Notes

- Size:** Standard sizes - from .250" to 2.500" inside diameter
- Load:** Typical dynamic loads - 4,000 to 30,000 psi, Ultimate 77,000 psi
- Motion:** Oscillatory, pivot, linear sliding and slow speed full rotation
- Friction:** Coefficients vary from .16 @ 500 psi to .07 @ 20,000 psi
- Electrical:** Filament wound back-up material is an electrical insulator
- Chemical:** Resistant to most chemicals, see Appendix or consult Rexnord engineer
- Temperature:** -65°F to +325°F for Continuous, 400°F for Intermittent - Style 702
-65°F to +250°F for Continuous or Intermittent - Style 703

For part number sizes shaded in gray please consult Rexnord Bearing Engineering

Thrust Washers



Woven PTFE Liner

Product Features

The thrust washer is constructed by bonding woven Teflon™ fiber fabric liner to one or both faces of a washer substrate. The substrate may be metallic, such as low carbon steel, stainless steel or aluminum. It may also be a non-metallic substrate such as NEMA grade G-10 or NEMA grade C. Standard washers are made with G-10 substrate.

Bearing Dimensions

Nominal Shaft Diameter	Part Number - 1/16" Thickness		B + .020 - .000	D + .000 - .020	T ± .005
	Lined One Face	Lined Both Faces			
0.250	707-00008-002	707-20008-002	0.270	0.500	0.062
0.312	707-00010-002	707-20010-002	0.332	0.625	0.062
0.375	707-00012-002	707-20012-002	0.395	0.750	0.062
0.437	707-00014-002	707-20014-002	0.457	0.875	0.062
0.500	707-00016-002	707-20016-002	0.520	1.000	0.062
0.625	707-00020-002	707-20020-002	0.645	1.250	0.062
0.750	707-00024-002	707-20024-002	0.770	1.500	0.062
0.875	707-00028-002	707-20028-002	0.895	1.750	0.062
1.000	707-00032-002	707-20032-002	1.020	2.000	0.062
1.125	707-00034-002	707-20034-002	1.145	2.125	0.062
1.250	707-00036-002	707-20036-002	1.270	2.250	0.062
1.375	707-00040-002	707-20040-002	1.395	2.500	0.062
1.500	707-00042-002	707-20042-002	1.520	2.625	0.062
1.625	707-00044-002	707-20044-002	1.645	2.750	0.062
1.750	707-00046-002	707-20046-002	1.770	2.875	0.062
1.875	707-00048-002	707-20048-002	1.895	3.000	0.062
2.000	707-00052-002	707-20052-002	2.020	3.250	0.062

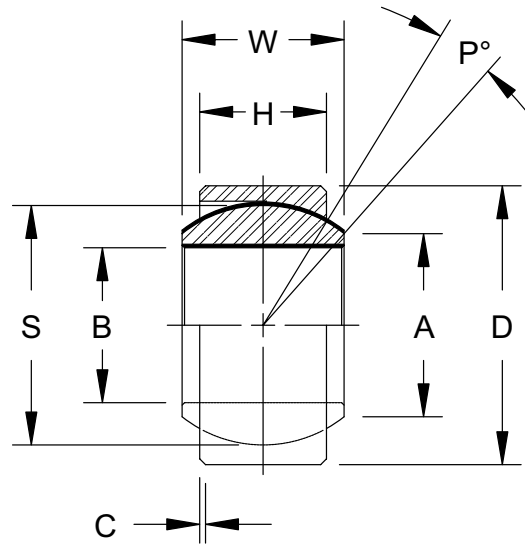
Nominal Shaft Diameter	Part Number - 1/8" Thickness		B + .020 - .000	D + .000 - .020	T ± .005
	Lined One Face	Lined Both Faces			
0.250	707-00008-004	707-20008-004	0.270	0.500	0.125
0.312	707-00010-004	707-20010-004	0.332	0.625	0.125
0.375	707-00012-004	707-20012-004	0.395	0.750	0.125
0.437	707-00014-004	707-20014-004	0.457	0.875	0.125
0.500	707-00016-004	707-20016-004	0.520	1.000	0.125
0.625	707-00020-004	707-20020-004	0.645	1.250	0.125
0.750	707-00024-004	707-20024-004	0.770	1.500	0.125
0.875	707-00028-004	707-20028-004	0.895	1.750	0.125
1.000	707-00032-004	707-20032-004	1.020	2.000	0.125
1.125	707-00034-004	707-20034-004	1.145	2.125	0.125
1.250	707-00036-004	707-20036-004	1.270	2.250	0.125
1.375	707-00040-004	707-20040-004	1.395	2.500	0.125
1.500	707-00042-004	707-20042-004	1.520	2.625	0.125
1.625	707-00044-004	707-20044-004	1.645	2.750	0.125
1.750	707-00046-004	707-20046-004	1.770	2.875	0.125
1.875	707-00048-004	707-20048-004	1.895	3.000	0.125
2.000	707-00052-004	707-20052-004	2.020	3.250	0.125

Additional Notes

- Size:** Standard sizes - from .250" to 2.000" inside diameter
- Load:** Typical dynamic loads - 4,000 to 20,000 psi, Ultimate 60,000 psi
- Motion:** Oscillatory and slow speed full rotation
- Friction:** Coefficients vary from .16 @ 500 psi to .07 @ 20,000 psi
- Electrical:** G-10 substrate material is an electrical insulator
- Chemical:** Resistant to most chemicals, see Appendix or consult Rexnord engineer
- Temperature:** Cryogenic to +250°F

For part number sizes shaded in gray please consult Rexnord Bearing Engineering

Annular Bearings



Product Features

The self-lubricating bearing element consists of a woven Teflon[™] fiber and polyester fiber liner supported by a filament wound continuous fiberglass fiber and epoxy resin matrix. The mating element (wear surface) is metallic.

Bearing Dimensions

Part Number	B +.000 -.001	D +.001 -.000	W +.000 -.005	H +.000 -.005	A (Ref)	C +.010 -.010	P Deg. Max	S Ball O.D.	Limit Load Rating- Lbs.
801-08-14-01	0.500	0.8750	0.437	0.375	0.571	0.015	6	0.719	5,400
801-12-20-01	0.750	1.2500	0.656	0.562	0.858			1.080	12,140
801-14-23-01	0.875	1.4375	0.765	0.656	0.999			1.258	16,500
801-16-26-01	1.000	1.6250	0.875	0.750	1.140			1.437	21,560
801-20-32-01	1.250	2.0000	1.093	0.937	1.424			1.795	33,640
801-22-35-01	1.375	2.1875	1.187	1.031	1.531			1.937	40,000
801-24-39-01	1.500	2.4375	1.312	1.125	1.710			2.155	48,480
801-28-45-01	1.750	2.8125	1.531	1.312	1.995			2.515	66,000
801-32-51-01	2.000	3.1875	1.750	1.500	2.281			2.875	86,250
801-36-57-01	2.250	3.5625	1.969	1.687	2.567			3.235	109,150
801-40-63-01	2.500	3.9375	2.187	1.875	2.847			3.590	134,620
801-48-76-01	3.000	4.7500	2.625	2.250	3.421			4.312	194,040
801-64-100-01	4.000	6.2500	3.500	3.000	4.562			5.750	345,000
801-80-124-01	5.000	7.7500	4.375	3.750	5.706			7.190	539,250
801-96-140-01	6.000	8.7500	4.750	4.125	6.630			8.156	672,870
821-04-10-01	0.2520	0.6562	0.3430	0.2500	0.4050			0.0200	12
821-05-12-01	0.3150	0.7500	0.3750	0.2810	0.4190	11	0.5625		7,490
821-06-13-01	0.3770	0.8125	0.4060	0.3120	0.4750	0.0250	10	0.6250	9,060
821-07-14-01	0.4400	0.9062	0.4370	0.3430	0.5290		9	0.6855	11,380
821-08-16-01	0.5020	1.0000	0.5000	0.3900	0.6400	0.0300	9	0.8125	15,750
821-09-18-01	0.5650	1.0937	0.5620	0.4370	0.6710		10	0.8750	18,980
821-10-19-01	0.6270	1.1875	0.6250	0.5000	0.7390	0.0300	9	0.9680	24,180
821-12-23-01	0.7520	1.4375	0.7500	0.5930	0.9200			1.1870	36,170
821-14-25-01	0.8770	1.5625	0.8750	0.7030	0.9780			1.3120	48,160
821-16-28-01	1.0020	1.7500	1.0000	0.7970	1.1180			1.5000	63,100
801-40-63-01	2.500	3.9375	2.187	1.875	2.847	0.015	6	3.590	134,620
801-48-76-01	3.000	4.7500	2.625	2.250	3.421			4.312	194,040
801-64-100-01	4.000	6.2500	3.500	3.000	4.562			5.750	345,000
801-80-124-01	5.000	7.7500	4.375	3.750	5.706			7.190	539,250
801-96-140-01	6.000	8.7500	4.750	4.125	6.630			8.156	672,870
								5	

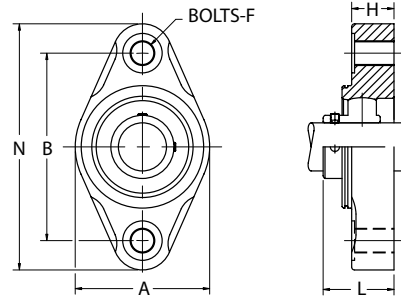
Additional Notes

Size: Standard sizes - from .250" (821 Series) to 6.000" (801 Series) inside diameter
Load: Typical dynamic loads - 4,000 to 20,000 psi
Motion: Oscillatory, pivot, slow speed full rotation, for linear consult Rexnord engineer
Friction: Coefficients vary from .16 @ 500 psi to .07 @ 20,000 psi
Electrical: The composite component filament wound back-up material is an electrical insulator
Chemical: Resistant to most chemicals, consult Rexnord engineer
Temperature: -65°F to +325°F for Continuous, 400°F for Intermittent

(801) bearings are supplied with 17- 4 PH Stainless Steel Ball. Consult Rexnord Engineering for other available materials

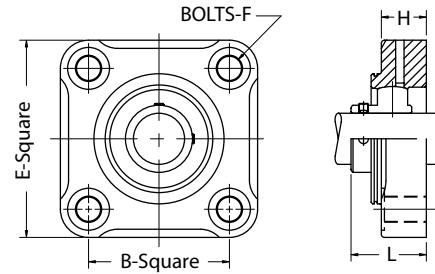
(821) Replaceable composite ball with metallic loader slot outer race

2-Bolt Flange Mounting



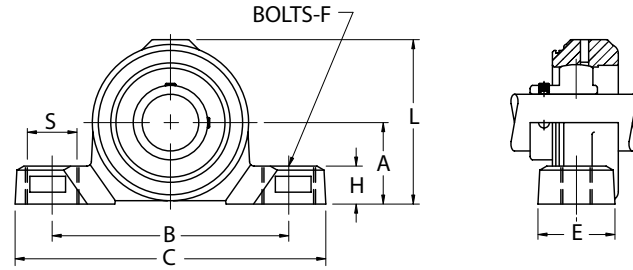
Part Number	Shaft Diameter	A	B	F Bolts	H	L Shaft Protector Length	N
DKLFXM012SP	3/4	2 7/16	3.543	3/8	51/64	1.44	4 9/16
DKLFXM013SP	13/16	2 13/16	3.898		7/8	1.5	5 1/8
DKLFXM014SP	7/8	2 13/16	3.898		7/8	1.5	5 1/8
DKLFXM015SP	15/16	2 13/16	3.898		7/8	1.5	5 1/8
DKLFXM016SP	1	2 13/16	3.898		7/8	1.5	5 1/8
DKLFXM017SP	1 1/16	3 11/32	4.606		1 1/64	1.82	5 53/64
DKLFXM018SP	1 1/8	3 11/32	4.606		1 1/64	1.82	5 53/64
DKLFXM019SP	1 3/16	3 11/32	4.606		1 1/64	1.82	5 53/64
DKLFXM02E20SP	1 1/4S	3 11/32	4.606		1 1/64	1.82	5 53/64
DKLFXM220SP	1 1/4	3 21/32	5.118		1 1/64	1.96	6 3/8
DKLFXM221SP	1 5/16	3 21/32	5.118		1 1/64	1.96	6 3/8
DKLFXM222SP	1 3/8	3 21/32	5.118		1 1/64	1.96	6 3/8
DKLFXM223SP	1 7/16	3 21/32	5.118		1 1/64	1.96	6 3/8
DKLFXM224SP	1 1/2	4 1/64	5.672		1 3/16	2.03	6 59/64

4-Bolt Flange Mounting



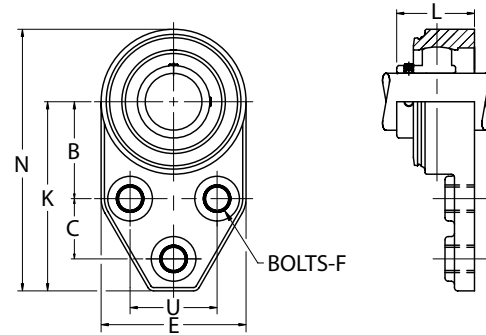
Part Number	Shaft Diameter	B	E	F Bolts	H	L Shaft Protector Length
DKLFM013SP	13/16	2.756	3 55/64	3/8	7/8	1.5
DKLFM014SP	7/8	2.756	3 55/64		7/8	1.5
DKLFM015SP	15/16	2.756	3 55/64		7/8	1.5
DKLFM016SP	1	2.756	3 55/64		7/8	1.5
DKLFM017SP	1 1/16	3.268	4 21/64		1 1/64	1.82
DKLFM018SP	1 1/8	3.268	4 21/64		1 1/64	1.82
DKLFM019SP	1 3/16	3.268	4 21/64		1 1/64	1.82
DKLFM02E20SP	1 1/4S	3.268	4 21/64		1 1/64	1.82
DKLFM220SP	1 1/4	3.622	4 23/32		1 1/64	1.96
DKLFM221SP	1 5/16	3.622	4 23/32		1 1/64	1.96
DKLFM222SP	1 3/8	3.622	4 23/32		1 1/64	1.96
DKLFM223SP	1 7/16	3.622	4 23/32		1 1/64	1.96
DKLFM224SP	1 1/2	4.016	5 5/32		1 3/16	2.03

Pillow Block



Part Number	Shaft Diameter	A	B	C	E	F Bolts	H	J	L	L Shaft Protector Length	S
DKLPM012SP	3/4	1 5/16	3 25/32	5 1/32	1 3/16	3/8	43/64	3/4	3 1/32	1.44	7/8
DKLPM013SP	13/16	1 7/16	4 11/16	5 31/64	1 23/64		43/64	13/16	3 11/32	1.5	7/8
DKLPM014SP	7/8	1 7/16	4 11/16	5 31/64	1 23/64		43/64	13/16	3 11/32	1.5	7/8
DKLPM015SP	15/16	1 7/16	4 11/16	5 31/64	1 23/64		43/64	13/16	3 11/32	1.5	7/8
DKLPM016SP	1	1 7/16	4 11/16	5 31/64	1 23/64		43/64	13/16	3 11/32	1.5	7/8
DKLPM017SP	1 1/16	1 11/16	4 49/64	6 27/64	1 27/64		25/32	61/64	3 55/64	1.82	15/16
DKLPM018SP	1 1/8	1 11/16	4 49/64	6 27/64	1 27/64		25/32	61/64	3 55/64	1.82	15/16
DKLPM019SP	1 3/16	1 11/16	4 49/64	6 27/64	1 27/64		25/32	61/64	3 55/64	1.82	15/16
DKLPM02E20SP	1 1/4S	1 11/16	4 49/64	6 27/64	1 27/64		25/32	61/64	3 55/64	1.82	15/16
DKLPM220SP	1 1/4	1 7/8	4 31/32	6 37/64	1 33/64		25/32	1 7/16	4 1/4	1.96	15/16
DKLPM221SP	1 5/16	1 7/8	4 31/32	6 37/64	1 33/64		25/32	1 7/16	4 1/4	1.96	15/16
DKLPM222SP	1 3/8	1 7/8	4 31/32	6 37/64	1 33/64		25/32	1 7/16	4 1/4	1.96	15/16
DKLPM223SP	1 7/16	1 7/8	4 31/32	6 37/64	1 33/64		25/32	1 7/16	4 1/4	1.96	15/16
DKLPM224SP	1 1/2	2	5 11/32	7 9/32	1 33/64		25/32	1 13/64	4 13/32	2.03	15/16

3 Bolt Flange Bracket



Part Number	Shaft Diameter	B	C	D	E	F Bolts	K	L Shaft Protector Length	N	U
DKLFBM013SP	13/16	1 13/16	1 1/8	1 11/64	2 23/32	3/8	3 17/32	1.5	4 57/64	1 5/8
DKLFBM014SP	7/8	1 13/16	1 1/8	1 11/64	2 23/32		3 17/32	1.5	4 57/64	1 5/8
DKLFBM015SP	15/16	1 13/16	1 1/8	1 11/64	2 23/32		3 17/32	1.5	4 57/64	1 5/8
DKLFBM016SP	1	1 13/16	1 1/8	1 11/64	2 23/32		3 17/32	1.5	4 57/64	1 5/8
DKLFBM017SP	1 1/16	2 1/16	1 1/4	1 11/32	3 13/64		3 55/64	1.82	5 15/32	1 7/8
DKLFBM018SP	1 1/8	2 1/16	1 1/4	1 11/32	3 13/64		3 55/64	1.82	5 15/32	1 7/8
DKLFBM019SP	1 3/16	2 1/16	1 1/4	1 11/32	3 13/64		3 55/64	1.82	5 15/32	1 7/8
DKLFBM02E20SP	1 1/4S	2 1/16	1 1/4	1 11/32	3 13/64		3 55/64	1.82	5 15/32	1 7/8
DKLFBM220SP	1 1/4	2 3/8	1 1/4	1 9/16	3 11/16	7/16	4 15/64	1.96	6 5/64	2
DKLFBM221SP	1 5/16	2 3/8	1 1/4	1 9/16	3 11/16		4 15/64	1.96	6 5/64	2
DKLFBM222SP	1 3/8	2 3/8	1 1/4	1 9/16	3 11/16		4 15/64	1.96	6 5/64	2
DKLFBM223SP	1 7/16	2 3/8	1 1/4	1 9/16	3 11/16		4 15/64	1.96	6 5/64	2

Sleeve Bearings

Rigid: Link-Belt



Contents

	Page
Features and Benefits	532
Nomenclature	533
Engineering	534
Dimensions	
Pillow Block	539
Flange Blocks	545
Take-up Assemblies	546
Replacement Parts	547

Industries Served

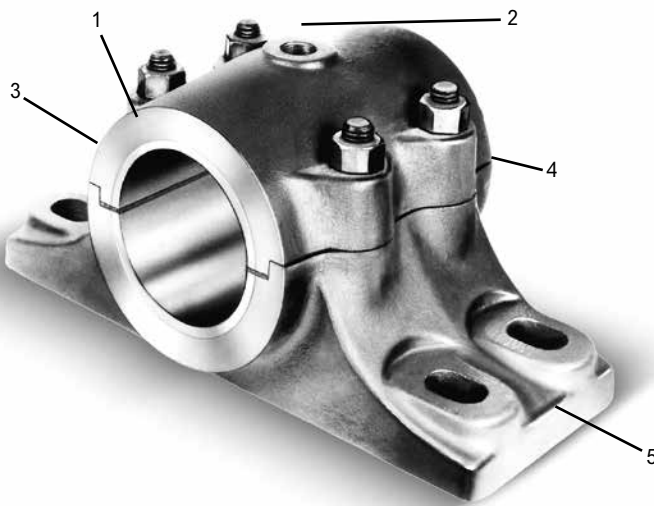
Wastewater Management
Industrial Furnace Applications
Dams
Highway Infrastructure
Forest Products
Air Handling



Rigid Sleeve Bearing Units and Take-ups

Rigid sleeve bearing units provide compact and reliable usage in applications where continuous operation and uninterrupted service are required. Because the bearing material wears gradually, sudden breakdowns and costly maintenance are minimized. Sleeve bearings can also operate extremely quietly. The standard bearing materials of babbitt, bronze and cast iron will handle a wide variety of applications such as on log decks, sewage treatment equipment, furnaces and ovens, quiet operating fans and blowers, power plant dampers and stokers, oscillating shaft applications and other general conveying and power transmission machinery. Babbitt bearings are used for moderate speeds and loads and ambient temperatures up to 130°F (54°C). Babbitt has the ability to give excellent service with a minimum of maintenance.

Bronze bearings are recommended for heavier loads, impact, and temperatures beyond the limits of babbitt bearings. They can be operated at ambient temperatures up to 300°F (149°C) providing satisfactory lubrication is available. Bronze has excellent all-around bearing characteristics; it has a relatively low coefficient of friction and a remarkable resistance to shock and wear.



1. Secure Mounting

Bearing of babbitt or bronze is securely anchored in housing.

2. Lubrication

Housing is drilled and tapped for grease cup or lubrication fitting; grooves distribute lubricant over loaded area.

3. Finished Ends

Finished ends permit flush mounting of pulley, sprocket, or collar against bearing when required.

4. Two-piece Pillow Block

Two-piece pillow block has shims to provide for adjustment and compensate for wear.

5. Finished Mounting Surface

Mounting surface is finished to provide firm seating on flat support.

One-piece Pillow Blocks

One-piece pillow blocks are recommended for general applications where it is unnecessary to remove a bearing cap. They are available with babbitt, bronze or plain bore cast iron bearings.



Two-piece Pillow Blocks

Two-piece pillow blocks are used whenever a bearing with a removable cap is required. They are available with babbitt or bronze bearings.

For heavy side pressures or angular loading, housings with gibbed joints provide greater strength. Cast steel housings are used where sudden shocks or heavy impact loads are encountered.



Flanged Units

Flanged units with square flanges have slotted mounting holes to make them interchangeable with most common ball and roller bearing bolting patterns. These units have either babbitt or bronze bearings.



Nomenclature

Symbol	Description	2K	15	95	F	Z-
None	One-piece housing, cast iron					
2—	Two-piece housing, cast iron					
2K	Two-piece housing, cast steel					
10	Pillow block, one-piece, 2-bolt base					
11	Pillow block, plain iron (no sleeve)					
12	Pillow block, angle type split joint, 2-bolt base					
13	Pillow block, angle type split joint, 4-bolt base					
14	Pillow block, horizontal gibbed joint, 4-bolt base					
15	Pillow block, angle type split joint, 40° off horizontal					
F22	Flanged unit, square, 4-bolt					
DS28	Take-up, conveyor, heavy rigid frame					
DSB28	Take-up, conveyor, heavy hinged frame					
95	Shaft diameter in 16ths of an inch					
F	4-bolt base (units 1000, 1100 only)					
None	Babbitt bearing (except units 1100)					
Z	Bronze bearing					
XX	Take-up adjustment, inches					

Rigid Sleeve Bearing Units Selection Guide

To select a rigid sleeve bearing, determine the applied radial load and the applicable operating conditions. The procedure shown here will aid in selecting an appropriate bearing.

The selection procedures and rating formulas used here are in agreement with industry standards for sleeve bearings established by the Mechanical Power Transmission Association. The bearing ratings apply when certain installation and operating conditions are met and when any other adverse ambient conditions such as high or low temperatures, extreme dirt or moisture, chemical contamination, shock or vibration loading direct or induced, oscillating shafts, intermittent operation and related factors are carefully considered.

The ratings used apply when the following conditions are met:

1. Align bearings with the shaft to provide uniform load distribution.
2. Normal running loads should not exceed the ratings shown in the tables. Starting and occasional peak loads should not exceed these ratings by more than 100%.
3. The direction of the load should not be within 30° (.53 radians) of either side of the grease groove and must further meet any load direction limitations imposed by Table 1.
4. The shaft finish through the bearing bore should be at least as smooth as that of normal commercial cold finished steel shafting (about 32 micro-inches or .82 μm). There should also be no machined or ground spiral lead on the shaft journal. Shafting should be within the diameter tolerances listed on the next page.
5. Ambient temperatures should not exceed 130°F (54°C) for babbitt and 300°F (149°C) for bronze bearings. This temperature limit applies to shafts extending from ovens, high temperature fans, etc.
6. Sturdy, vibration-free supporting structures must be provided, along with adequate grease lubrication.

Steps for Selection

Step 1

From Table 1, select the bearing material and housing series and material suitable for the radial load direction.

Step 2






Refer to the radial load rating tables in the Load Ratings and Speed Limits section to determine the shaft diameter necessary to obtain the required radial rating at the given speed.

If the conditions described above cannot be met, the load should be increased by a service factor prior to selecting the bearing sizes from the tables shown in the Load Ratings and Speed Limits section. The service factor may be as high as 2.0 for conditions to the left of the "stair-step" line, or as high as 3.0 for conditions to the right of the line. Consult Rexnord Bearing Division.

Step 3

To position a shaft axially or where light thrust loads are present, provide thick bronze washers backed by a shaft collar or a machined shaft shoulder against the end of the bearing. The bearing ends are already machined.

Table 1 – Bearing material and unit type selection

Material		Recommended Loading Range, Degrees, Radius For Pillow Block Or Flanged Unit*	Available Shaft Sizes, inches	Rigid unit series			
Bearing	Housing			Pillow Block		Flanged Unit	
				2-bolt	4-bolt	Square	
Cast iron	one-piece		300° 5.2 rad	1/2 - 2 15/16	1000		
				3/4 - 3 15/16		F2200	
				3 7/16 - 3 15/16		1000F	
	Babbitt	two-piece		120° 2.1 rad	7/8 - 3 15/16	2-1200	
					3 7/16 - 4 15/16		2-1300
					1 15/16 - 8		2-1400
Bronze	one-piece		300° 5.2 rad	1/2 - 2 15/16	1000Z		
				3/4 - 3 15/16		F2200Z	
				3 7/16 - 3 15/16		1000FZ	
	Cast iron	two-piece		120° 2.1 rad	7/8 - 3 15/16	2-1200Z	
					1 15/16 - 8		2-1400Z
					1 15/16 - 8		2-1500Z
Cast steel	two-piece		300° 5.2 rad	1 15/16 - 12		2K1400Z	

* Shaded portion of drawings represents recommended loading range with the grease groove horizontal and opposite the loaded area. For other positioning, consult Rexnord Bearing Division.

□ 300°(5.2 rad.) for housings with gibbed joint construction.

Additional Information

Sleeve Bearing Materials:

Plain bearings made of babbitt are universally accepted as providing reasonable capacity and dependable service, often under adverse conditions. Babbitt is a relatively soft bearing material and for this reason minimizes danger of scoring or damage to shafts or rotors. It can often be repaired quickly on the spot by rescrapping, pouring of new metal, etc. Bearing operating temperature should not exceed 130°F (54°C) although occasional peaks to 200°F (93°C) may be tolerated. Babbitt bearings are usually restricted to applications involving light to moderate loads and mild shock.

Bronze bearings are suitable for heavier loads than babbitt (75% to 200% higher), depending upon specific conditions of load and speed. Bronze withstands higher shock loads and permits somewhat higher speed operation. It is usually restricted to 300°F (150°C) ambient temperature, although normal multi-purpose greases are limited to 200°-250°F (93°-121°C) operating temperature. Bronze is a harder material than babbitt and has a greater tendency to score or damage shafts in the event of malfunction such as lack of relubrication. Field repair of bronze bearings generally requires removing shims and scraping or replacement of bushings.

Cast iron bearings (series 1100) are low in cost and suitable for many slow moving shafts and oscillating or reciprocating arms supporting relatively light loads. The lubricating characteristics of cast iron are attributed to the free graphite flakes present in the material. With the use of cast iron bearings, higher shaft clearance is usually utilized. Thus any large wear particles or debris will not join or seize the bearing. This material has been used to temperatures as high as 1000°F (538°C) under light loads and slow speed intermittent operations, where ordinary lubricants are ineffective.

Additional Features:

By the very nature of their design, all rigid sleeve bearing units are expansion type, in that the shaft journal is free to slide axially through the bore of the bearing. To fix a unit, a combination of shaft shoulders and/or thrust collars with bronze washers can be utilized. Rigid sleeve bearing units have cored mounting bolt holes suitable for the inch or metric bolts listed.

Bearings can be replaced in units with bronze sleeves. Care should be taken when replacing bronze sleeves, split or solid, to firmly anchor the sleeve to the housing.

Operation:

Rigid sleeve bearing units are not prelubricated. The service instructions packed with shipments provide guide lines for initial lubrication and relubrication intervals. As lack of lubrication results in bearing and shaft wear, care must be taken to assure an adequate supply of correct lubricant, especially during initial start-up and until satisfactory relubrication intervals are determined. Very careful shaft alignment is necessary during installation. Shaft journals must turn freely without binding in the bearing or excessive heat and seizure can result. Any factor which may disrupt or remove the lubricant film should be eliminated as well. Sharp edges on the shaft or the bearing surface can act as scrapers to destroy lubricant films. Do not extend shaft keyways into bearing bores. When rigid sleeve bearings must carry light to medium thrust loads, thrust washers of bronze should be placed against the already machined face of the bearing and backed by substantial thrust collars, shaft shoulders, machined gear, sprocket or sheave faces, etc.

Take-ups:

Rigid sleeve bearing pillow blocks can be mounted on the universal take-up frame LC, and LHD universal take-up frame. Alignment of rigid sleeve bearing take-ups is difficult and must be carefully accomplished. Alignment must also be maintained during any further adjustment of the take-up after operation. Bolt take-up frames firmly to good supporting structure to prevent frame overload and distortion.

Shaft Tolerances:

Shaft diameters for rigid sleeve bearing units are usually held to the following regular commercial tolerances:

Shaft Diameters	Recommended Tolerance
through 2"	Nominal to -.003"
2 1/16" through 4"	Nominal to -.004"
4 1/16" through 6"	Nominal to -.005"
6 1/16" through 13"	Nominal to -.006"

Warning:

The reliability built in all Rexnord bearings can be realized in service only when bearings are correctly selected, properly installed, protected and maintained.

The correct selection of rigid sleeve bearing mounted units requires that the magnitude and nature of all loads, speeds, alignment, mounting, operating requirements and maintenance be adequately considered. The selection of materials for and design of housings, shafting, fasteners, and accessories as well as provisions for installation and maintenance must follow good engineering principles.

Housings must be selected and installed with regard to the degree and direction of the forces that will occur. Housings should not be used under tension loads except with adequate safety factors. For this reason pillow blocks are best suited to withstand radial loads passing through the base. When heavy loads or shock loads are possible, it is most important to mount a unit so that the line of force passes directly into the base, or so that the unit is directly and substantially supported other than through its mounting bolts.

Where the line of force falls outside the base, serious housing and fastener deflection or failure may occur.

Take-ups are best located where loads are moderate and no shock loads are present. As many mounting arrangements are possible with take-ups, proper safety factors must always be considered on all items of the system, including shafts, housings, fasteners, and adjusting screws. Rexnord Bearing Division, should be consulted where unusual loading conditions exist.

Load Ratings – Babbitt Rigid Sleeve Bearing Units

Radial Load Ratings for 10 to 300 RPM (pounds/newtons) * ■

Shaft Diameter, inches	Shaft Speed, RPM													
	10		50		100		150		200		250		300	
1/2	100	445	100	445	100	445	95	423	95	423	95	423	95	423
5/8	150	667	150	667	145	645	145	645	140	623	140	673	135	600
3/4	180	801	175	778	175	778	170	756	170	756	165	734	160	712
7/8	260	1157	255	1134	250	1112	245	1090	240	1068	235	1045	230	1023
15/16	280	1246	275	1223	265	1179	260	1157	255	1134	250	1112	245	1090
1	295	1312	290	1290	285	1268	280	1246	270	1201	265	1179	260	1157
1 1/8	415	1846	410	1824	400	1779	390	1735	380	1690	370	1646	355	1579
1 3/16, 1 1/4	440	1957	430	1913	420	1868	410	1824	395	1757	385	1713	375	1668
1 5/16, 1 3/8,	585	2602	570	2535	555	2469	535	2380	520	2313	505	2246	485	2157
1 7/16, 1 1/2	640	2847	625	2780	605	2691	585	2602	565	2513	545	2424	525	2335
1 11/16, 1 3/4	875	3892	850	3781	820	3648	785	3492	755	3358	720	3203	690	3069
1 15/16, 2	1150	5120	1110	4940	1060	4720	1010	4490	965	4292	915	4070	865	3848
2 3/16, 2 1/4	1460	6490	1400	6230	1330	5920	1260	5600	1190	5290	1120	4980	1050	4670
2 7/16, 2 1/2	1800	8010	1730	7690	1630	7250	1530	6810	1430	6360	1340	5960	1240	5520
2 11/16, 2 3/4	2190	9740	2080	9250	1950	8670	1820	8100	1690	7520	1560	6940	1150	5120
2 15/16, 3	2600	11570	2470	10990	2300	10230	2130	9470	1960	8720	1790	7960	675	3002
3 7/16, 3 1/2	3550	15790	3330	14810	3060	13610	2790	12410	2520	11210	1200	5340		
3 15/16, 4	4640	20640	4310	19170	3910	17390	3500	15570	2760	12280				
4 7/8, 4 1/2	5870	26110	5410	24060	4830	21480	4250	18900	1410	6270				
4 15/16, 5	7240	32210	6600	29360	5810	25840	5010	22290						
5 7/16, 5 1/2	8750	38920	7900	35140	6840	43030	4360	19390						
5 15/16, 6	10410	46310	9300	41370	7910	35190	2390	10630						
6 7/16, 6 1/2	12200	54270	10790	48000	9020	40120								
6 15/16, 7	14120	62810	12360	54980	10150	45150								
7 7/16, 7 1/2	17270	76820	14950	66500	12050	53600								
7 15/16, 8	18390	81800	15750	70060	10710	47640								
9	20750	92300	17360	77220	4140	18420								
10	22950	102090	18760	83450										
12	30700	136560	23910	106360										

For speeds lower than 10 RPM
consult Rexnord Bearing Division.

Radial Load Rating for 350 to 1000 RPM (pounds/newtons) *

Shaft Diameter, inches	Shaft Speed, RPM																	
	350		400		450		500		600		700		800		900		1000	
1/2	95	423	90	400	90	400	90	400	85	378	85	378	85	378	80	356	80	356
5/8	135	600	135	600	130	587	130	587	125	556	120	534	115	512	110	489	110	489
3/4	160	712	155	689	155	689	150	667	145	645	140	623	130	578	125	556	120	534
7/8	225	1001	220	979	215	956	210	934	200	890	190	845	180	801	150	667		
15/16	240	1068	235	1045	225	1001	220	979	210	934	200	890	185	823	105	467		
1	250	1112	245	1090	240	1068	230	1023	220	979	205	912						
1 1/8	345	1535	335	1490	325	1446	315	1401	295	1312	245	1090						
1 3/16, 1 1/4	360	1601	350	1557	340	1512	325	1446	305	1357	190	845						
1 5/16, 1 3/8,	470	2091	455	2024	435	1935	420	1868	345	1535								
1 7/16, 1 1/2	500	2224	480	2135	460	2046	440	1957	205	912								
1 11/16, 1 3/4	655	2914	625	2780	590	2624	340	1512										
1 15/16, 2	815	3625	730	3247	335	1490												
2 3/16, 2 1/4	975	4337	410	1824														
2 7/16, 2 1/2	645	2869																

■ Load ratings are based on industry standards established by the Mechanical Power Transmission Association.

* For plain bore Cast Iron Sleeve Bearing Units use radial load ratings at speeds to the left of the shaded area.

Load Ratings – Bronze Rigid Sleeve Bearing Units

Radial Load Rating for 10 to 300 RPM (pounds/newtons) ■

Shaft Diameter, inches	Shaft Speed, RPM													
	10		50		100		150		200		250		300	
1/2	200	890	200	890	200	890	195	867	195	867	195	867	195	867
5/8	250	1112	250	1112	245	1090	245	1090	240	1090	240	1068	240	1068
3/4	300	1334	300	1334	295	1312	295	1312	290	1290	285	1268	285	1268
7/8	435	1935	430	1913	425	1890	420	1868	415	1846	410	1824	405	1802
15/16	465	2068	460	2046	455	2024	450	2002	445	1979	435	1935	430	1913
1	495	2202	490	2180	485	2157	480	2135	470	2091	465	2068	460	2046
1 1/8	700	3114	690	3069	680	3025	670	2980	660	2936	650	2891	640	2847
1 3/16, 1 1/4	735	3269	730	3247	715	3180	705	3136	695	3092	680	3025	670	2980
1 5/16, 1 3/8,	980	4359	965	4293	950	4226	930	4137	915	4070	895	3981	880	3914
1 7/16, 1 1/2	1070	4760	1050	4670	1030	4580	1010	4490	995	4426	975	4337	955	4248
1 11/16, 1 3/4	1470	6540	1440	6410	1410	6270	1370	6090	1340	5960	1310	5830	1280	5690
1 15/16, 2	1920	8540	1880	8360	1830	8140	1790	7960	1740	7740	1690	7520	1640	7300
2 3/16, 2 1/4	2440	10850	2390	10630	2320	10320	2240	9960	2170	9650	2100	9340	2030	9030
2 7/16, 2 1/2	3020	13430	2940	13080	2850	12680	2750	12230	2650	11790	2560	11390	2460	10940
2 11/16, 2 3/4	3660	16280	3560	15840	3430	15260	3300	14680	3170	14100	3040	13520	2620	11650
2 15/16, 3	4370	19440	4230	18820	4060	18060	3890	17300	3720	16550	3550	15790	2440	10850
3 7/16, 3 1/2	5960	26510	5740	25530	5470	24330	5200	23130	4930	21930	3610	16060	1440	6410
3 15/16, 4	7790	34650	7460	33180	7060	31400	6650	29580	5910	26290				
4 7/8, 4 1/2	9860	43860	9400	41810	8820	39230	8240	36650	5400	24020				
4 15/16, 5	12180	54180	11540	51330	10740	47770	9950	44260	4090	18190				
5 7/16, 5 1/2	14740	65570	13880	61740	12820	57030	10340	45990	1820	8100				
5 15/16, 6	17530	77980	16420	73040	15040	66900	9520	42350						
6 7/16, 6 1/2	20560	91460	19150	85180	17390	77350	7900	35140						
6 15/16, 7	23840	106050	22070	98170	19870	88390	5350	23800						
7 7/16, 7 1/2	29170	129750	26850	119430	23950	106530	1880	8360						
7 15/16, 8	31090	138300	28450	126550	23410	104130								
9	35150	156360	31760	141280	18540	82470								
10	38950	172260	34760	154620	12220	54360								
12	52300	232640	45520	202480										

For speeds lower than 10 RPM
consult Rexnord Bearing Division.

Radial Load Rating for 350 to 1000 RPM (pounds/newtons)

Shaft Diameter, inches	Shaft Speed, RPM																	
	350	400	450	500	600	700	800	900	1000									
1/2	195	867	190	845	190	845	190	845	185	823	185	823	185	823	180	800	180	800
5/8	235	1045	235	1045	235	1045	230	1023	225	1001	220	979	220	979	215	956	210	934
3/4	280	1246	280	1246	275	1223	270	1201	265	1179	260	1157	255	1134	250	1112	240	1068
7/8	400	1779	395	1757	390	1735	385	1713	375	1668	365	1624	355	1579	325	1446	245	1090
15/16	425	1890	420	1868	415	1846	410	1824	395	1757	385	1713	375	1668	295	1312	200	890
1	450	2002	445	1979	440	1957	430	1913	420	1868	405	1802	360	1601	255	1134	150	667
1 1/8	630	2802	620	2758	605	2691	595	2647	575	2558	525	2335	360	1601	195	867		
1 3/16, 1 1/4	660	2936	645	2869	635	2825	625	2780	600	2669	485	2157	300	1334	115	512		
1 5/16, 1 3/8,	865	3848	845	3759	830	3692	815	3625	735	3269	465	2068	195	867				
1 7/16, 1 1/2	935	4159	915	4070	895	3981	875	3892	635	2825	315	1401						
1 11/16, 1 3/4	1240	5520	1210	5380	1180	5250	930	4137	410	1824								
1 15/16, 2	1590	7070	1500	6670	1110	4940												
2 3/16, 2 1/4	1960	8720	1390	6180	830	3692												
2 7/16, 2 1/2	1860	8270	1090	4850														
2 11/16, 2 3/4	1580	7030	545	2424														

■ Load ratings are based on industry standards established by the Mechanical Power Transmission Association.

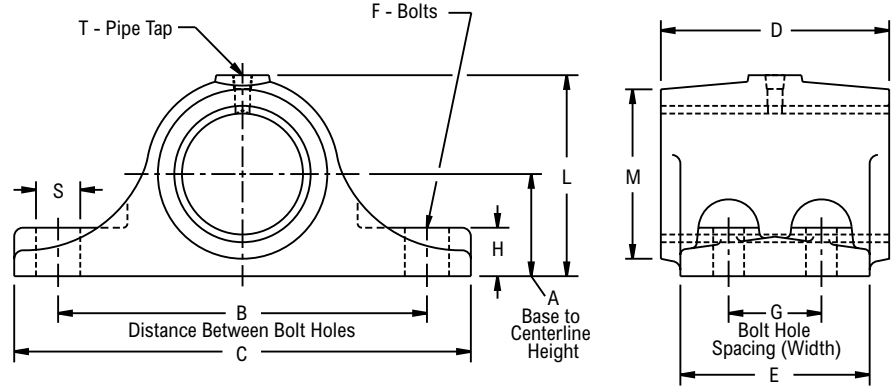
1000, 1000Z



Photo Shows a 2-Bolt Rigid Sleeve Bearing Pillow Block Unit with Bronze Bushing

Product Features

- Corrosion-resistant powder coating
- Cast iron one piece housing
- Babbitt or Bronze sleeve
- 2 or 4-bolt base
- Relubricatable
- See Features and Benefits for additional info on page 532.



Bearing Dimensions

Shaft Diameter	Babbitt	Bronze	A Base to Centerline Height	B Distance Between Bolt Holes	G Bolt Hole Spacing (Width)	C	D	E	F	H	L	M	S	T	Approx. Weight
	Part Number	Part Number													
2-Bolt															
1/2	1008	1008Z	3/4	2 3/8	-	3 1/4	1 3/8	1	5/16	3/8	1 1/2	1 3/16	1/2	1/8	0.80
5/8	1010	1010Z	7/8	3	-	4 1/4	2	1 3/8	3/8	1/2	1 3/4	1 1/2	5/8	1/8	1.60
3/4	1012	1012Z													1.50
7/8	1014	1014Z	1	3 1/4	-	4 1/2	2	1 3/8	3/8	1/2	1 31/32	1 3/4	5/8	1/8	1.90
15/16	1015	1015Z													1.70
1	1016	1016Z													1.60
1 1/8	1018	1018Z	1 1/4	4	-	5 1/4	2 1/2	1 5/8	3/8	5/8	2 3/8	2	5/8	1/8	2.60
1 3/16	1019	1019Z													2.50
1 1/4	1020	1020Z													2.40
1 3/8	1022	1022Z													4.50
1 7/16	1023	1023Z													4.30
1 1/2	1024	1024Z	4.10												
1 11/16	1027	1027Z	1 5/8	5 1/2	-	7 1/4	3 1/2	2 1/4	1/2	3/4	3 3/16	2 3/4	7/8	1/4	6.00
1 3/4	1028	1028Z													5.70
1 15/16	1031	1031Z													8.50
2	1032	1032Z	1 3/4	6	-	8	4	2 3/4	5/8	7/8	3 1/2	3 1/8	1	1/4	8.30
2 3/16	1035	1035Z	2	6 1/2	-	8 1/2	4 1/2	3	5/8	1	3 7/8	3 3/8	1	3/8	11.00
2 7/16	1039	1039Z	2 1/4	7	-	9 1/4	5	3 1/4	3/4	1 1/8	4 3/8	3 3/4	1 1/8	3/8	15.00
2 15/16	1047	1047Z	2 1/2	8 1/2	-	11 1/4	6	4	7/8	1 1/4	5	4 1/2	1 3/8	3/8	26.00
4-Bolt															
3 7/16	1055F	1055FZ	3	10	2 3/4	12 1/2	7	5	3/4	1 3/8	6	5 1/4	1 1/4	1/2	39.00
3 15/16	1063F	1063FZ	3 1/4	11	3	13 3/4	8	5 1/2	3/4	1 1/2	6 9/16	5 7/8	1 3/8	1/2	54.00

Additional Notes

- Please call 1-866-REXNORD for availability
- One pipe tapped hole for lubrication
- Grease cup or fitting not included
- For the Selection Guide, Load Ratings and Speed Limits, see the Link-Belt Sleeve Bearing Engineering section on pages 534 - 537.
- Note: Dimensions subject to change. Certified dimensions of ordered material furnished on request.

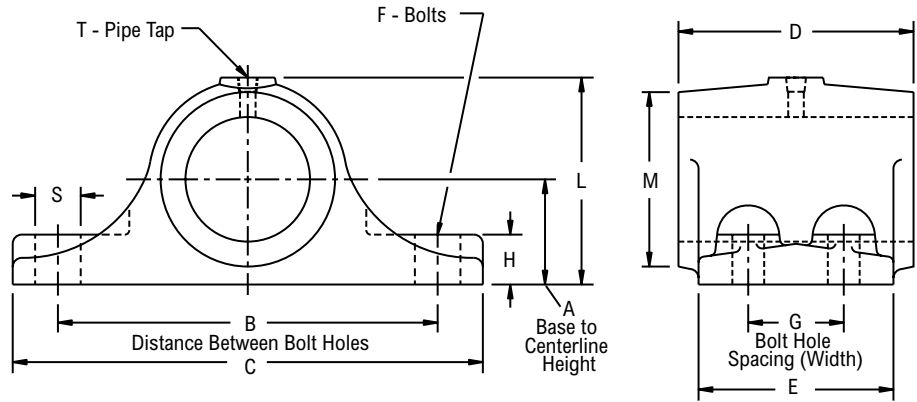
1100



Photo Shows a 2-Bolt Rigid Sleeve Bearing Pillow Block Unit with Cast Iron Bushing

Product Features

- Corrosion-resistant powder coating
- Cast iron one piece housing
- Cast iron sleeve
- 2 or 4-bolt base
- Relubricatable
- See Features and Benefits for additional info on page 532.



Bearing Dimensions

Shaft Diameter	Part Number	A Base to Centerline Height	B Distance Between Bolt Holes	G Bolt Hole Spacing (Width)	C	D	E	F	H	L	M	S	T	Approx. Weight
2-Bolt														
3/4	1112	3/4	2 3/8	-	3 1/4	1 3/8	1	5/16	3/8	1 1/2	1 3/16	1/2	1/8	0.60
7/8	1114	7/8	3	-	4 1/4	2	1 3/8	3/8	1/2	1 3/4	1 1/2	5/8	1/8	1.40
15/16	1115													1.30
1	1116													1.20
1 1/8	1118	1	3 1/4	-	4 1/2	2	1 3/8	3/8	1/2	1 31/32	1 3/4	5/8	1/8	1.60
1 3/16	1119													1.50
1 1/4	1120													1.40
1 7/16	1123	1 1/4	4	-	5 1/4	2 1/2	1 5/8	3/8	5/8	2 3/8	2	5/8	1/8	2.10
1 1/2	1124													2.00
1 11/16	1127	1 3/8	5	-	6 3/4	3	2	1/2	3/4	2 11/16	2 3/8	13/16	1/4	3.50
1 3/4	1128													3.40
1 15/16	1131	1 5/8	5 1/2	-	7 1/4	3 1/2	2 1/4	1/2	3/4	3 3/16	2 3/4	7/8	1/4	5.00
2	1132													4.90
2 3/16	1135	1 3/4	6	-	8	4	2 3/4	5/8	7/8	3 1/2	3 1/8	1	3/8	6.80
2 7/16	1139	2	6 1/2	-	8 1/2	4 1/2	3	5/8	1	3 7/8	3 3/8	1	3/8	9.00
2 11/16	1143	2 1/4	7	-	9 1/4	5	3 1/4	3/4	1 1/8	4 3/8	3 3/4	1 1/8	3/8	12.00
2 15/16	1147													11.00
3 1/16	1155													19.00
4-Bolt														
3 15/16	1163F	3	10	2 3/4	12 1/2	7	5	3/4	1 3/8	6	5 1/4	1 1/4	1/2	31.00

Additional Notes

- Please call 1-866-REXNORD for availability
- One pipe tapped hole for lubrication
- Grease cup or fitting not included
- Note: Approximate load ratings from babbit ratings
- For the Selection Guide, Load Ratings and Speed Limits, see the Link-Belt Sleeve Bearing Engineering section on pages 534 - 537.
- Note: Dimensions subject to change. Certified dimensions of ordered material furnished on request.

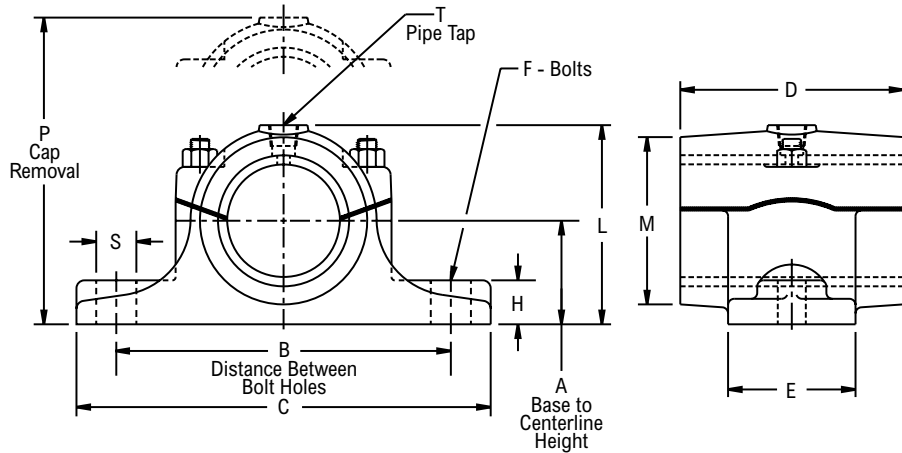
21200, 21200Z



Photo Shows a 2-Bolt Rigid Sleeve Bearing Two-Piece Pillow Block Unit with Bronze Bushing

Product Features

- Corrosion-resistant powder coating
- Cast iron two piece housing
- Babbitt or Bronze sleeve
- 2-bolt base
- Relubricatable
- See Features and Benefits for additional info on page 532.



Bearing Dimensions

Shaft Diameter	Babbitt	Bronze	A Base to Centerline Height	B Distance Between Bolt Holes	C	D	E	F	H	L	M	P	S	T	Approx. Weight
	Part Number	Part Number													
7/8	21214	21214Z	1	3 5/8	4 3/4	2	1 3/8	3/8	9/16	2 1/16	1 13/16	3	9/16	1/8	1.90
15/16	21215	21215Z													1.80
1	21216	21216Z													1.70
1 1/16	21217	21217Z	1 1/4	4 1/8	5 1/4	2 1/2	1 5/8	3/8	5/8	2 7/16	2	3 1/2	5/8	1/8	2.60
1 1/8	21218	21218Z													2.50
1 3/16	21219	21219Z													2.40
1 1/4	21220	21220Z													2.30
1 5/16	21221	21221Z													4.10
1 3/8	21222	21222Z	1 3/8	4 7/8	6 1/4	3	2	1/2	3/4	2 11/16	2 5/16	3 7/8	11/16	1/4	4.00
1 7/16	21223	21223Z													3.80
1 1/2	21224	21224Z													6.80
1 9/16	21225	21225Z													6.40
1 5/8	21226	21226Z	1 1/2	5 1/4	6 3/4	3 1/2	2 1/4	1/2	13/16	3	2 11/16	4 3/8	3/4	1/4	6.00
1 11/16	21227	21227Z													5.60
1 3/4	21228	21228Z													5.60
1 15/16	21231	21231Z													8.50
2	21232	21232Z													8.00
2 3/16	21235	21235Z	1 7/8	6 1/2	8 1/2	4 1/2	2 3/4	5/8	1	3 3/4	3 3/8	5 1/4	1	3/8	11.00
2 1/4	21236	21236Z													14.00
2 7/16	21239	21239Z													13.00
2 1/2	21240	21240Z	2 1/8	7	8 7/8	5	3	5/8	1 1/8	4 3/16	3 3/4	5 3/4	1	3/8	19.00
2 11/16	21243	21243Z													23.00
2 5/16	21247	21247Z	2 1/2	8 1/2	10 3/4	6	3 1/2	3/4	1 5/16	4 7/8	4 1/4	6 3/4	1 1/8	3/8	22.00
3	21248	21248Z													35.00
3 7/16	21255	21255Z													48.00
3 15/16	21263	21263Z	3 1/8	10 1/2	13 1/2	8	4 1/2	1	1 5/8	6 3/16	5 5/8	8 1/2	1 1/2	1/2	

Additional Notes

- Please call 1-866-REXNORD for availability
- One pipe tapped hole for lubrication
- Grease cup or fitting not included
- LHD sliding base take-up can be drilled for these pillow blocks
- For the Selection Guide, Load Ratings and Speed Limits, see the Link-Belt Sleeve Bearing Engineering section on pages 534 - 537.
- Note: Dimensions subject to change. Certified dimensions of ordered material furnished on request.

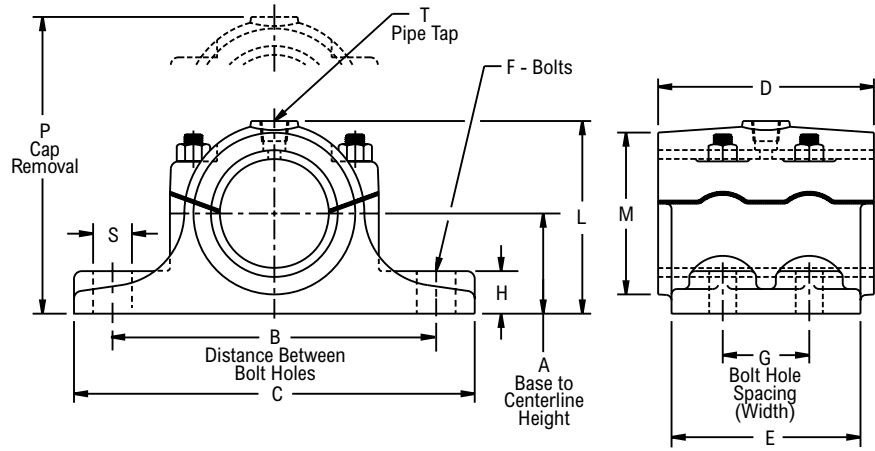
21300



Photo Shows a 4-Bolt Rigid Sleeve Bearing Two-Piece Pillow Block Unit with Babbitt Bushing

Product Features

- Corrosion-resistant powder coating
- Cast iron two piece housing
- Babbitt sleeve
- 4-bolt base
- Relubricatable
- See Features and Benefits for additional info on page 532.



Bearing Dimensions

Shaft Diameter	Part Number	A Base to Centerline Height	B Distance Between Bolt Holes	G Bolt Hole Spacing (Width)	C	D	E	F	H	L	M	P	S	T	Approx. Weight
4-Bolt															
3 ⁷ / ₁₆	21355	3 ¹ / ₄	10 ¹ / ₂	2 ³ / ₄	13	7	5	³ / ₄	1 ³ / ₈	6 ¹ / ₄	5 ¹ / ₄	8 ¹ / ₈	1 ¹ / ₄	¹ / ₂	43.00
3 ¹⁵ / ₁₆	21363	3 ¹ / ₂	12	3	14 ³ / ₄	8	5 ¹ / ₂	³ / ₄	1 ¹ / ₂	6 ¹³ / ₁₆	5 ⁷ / ₈	9 ³ / ₈	1 ³ / ₈	¹ / ₂	61.00
4 ⁷ / ₁₆	21371	4 ¹ / ₈	13 ¹ / ₂	3 ¹ / ₂	16 ¹ / ₂	9	6 ¹ / ₄	⁷ / ₈	1 ³ / ₄	7 ⁷ / ₈	6 ⁵ / ₈	10 ³ / ₈	1 ¹ / ₂	¹ / ₂	92.00
4 ¹⁵ / ₁₆	21379	4 ¹ / ₂	15	4	18	10	7	⁷ / ₈	1 ⁷ / ₈	8 ⁹ / ₁₆	7 ¹ / ₄	11 ³ / ₈	1 ⁵ / ₈	¹ / ₂	116.00

Additional Notes

- Please call 1-866-REXNORD for availability
- One pipe tapped hole for lubrication
- Grease cup or fitting not included
- For the Selection Guide, Load Ratings and Speed Limits, see the Link-Belt Sleeve Bearing Engineering section on pages 534 - 537.
- Note: Dimensions subject to change. Certified dimensions of ordered material furnished on request.

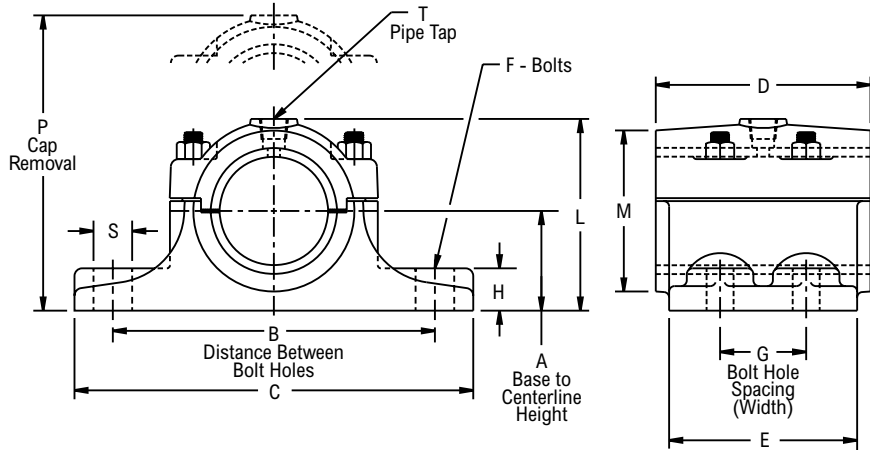
21400, 21400Z, 2K1400Z



Photo Shows a 4-Bolt Rigid Sleeve Bearing Two-Piece Pillow Block Unit with Bronze Bushing

Product Features

- Corrosion-resistant powder coating
- Cast iron or cast steel housing
- Two-piece gibbed joint design
- Babbitt or Bronze sleeve
- 4-bolt base
- Relubricatable
- See Features and Benefits for additional info on page 532.



Bearing Dimensions

Shaft Diameter	Babbitt	Bronze	A Base to Centerline Height	B Distance Between Bolt Holes	G Bolt Hole Spacing (Width)	C	D	E	F	H	L	M	P	S	T	Approx. Weight
	Part Number	Part Number														
Cast Iron																
1 15/16	21431	21431Z	1 3/4	6 1/2	1 3/4	8 1/4	4	3 1/2	1/2	7/8	3 7/16	3	4 1/2	3/4	1/4	10.00
2 3/16	21435	21435Z	1 7/8	6 3/4	1 3/4	8 1/2	4 1/2	3 1/2	1/2	1	3 3/4	3 3/8	4 15/16	3/4	3/8	14.00
2 7/16	21439	21439Z	2 1/8	8	2	10 1/4	5	4	5/8	1 1/8	4 3/16	3 3/4	5 3/8	1	3/8	19.00
2 11/16	21443	21443Z	2 1/4	8 1/4	2 1/4	10 1/2	5 1/2	4 1/4	5/8	1 1/4	4 1/2	4	6	1	3/8	25.00
2 15/16	21447	21447Z	2 1/2	8 3/4	2 1/2	11	6	4 1/2	5/8	1 3/8	4 7/8	4 1/4	6 7/8	1	3/8	30.00
3 7/16	21455	21455Z	3 1/4	10 1/2	2 3/4	13	7	5	3/4	1 3/8	6 1/4	5 1/4	8 9/32	1 1/4	1/2	43.00
3 15/16	21463	21463Z	3 1/2	12	3	14 3/4	8	5 1/2	3/4	1 1/2	6 13/16	5 7/8	9 13/16	1 3/8	1/2	61.00
4 7/16	21471	21471Z	4 1/8	13 1/2	3 1/2	16 1/2	9	6 1/4	7/8	1 3/4	7 7/8	6 5/8	10 1/4	1 1/2	1/2	92.00
4 15/16	21479	21479Z	4 1/2	15	4	18	10	7	7/8	1 7/8	8 9/16	7 1/4	11 3/16	1 5/8	1/2	119.00
5 7/16	21487	-	5	15 3/4	4 1/2	19 1/4	11	7 3/4	1	2	9 3/8	7 7/8	12 1/4	1 3/4	1/2	166.00
5 15/16	21495	21495Z	5 1/2	16 1/2	5	20 1/2	12	8 1/2	1 1/8	2 1/8	10 1/4	8 1/2	13 7/8	1 7/8	1/2	198.00
6 7/16	214103	214103Z	6	18	5 1/2	22	13	9 1/2	1 1/8	2 1/4	11	9 1/8	15 1/8	1 7/8	1/2	260.00
6 1/2	214104	214104Z														255.00
7	214112	214112Z	6 1/2	19	6	23	14	10	1 1/4	2 3/8	11 3/4	9 3/4	15 7/8	2	1/2	311.00
8	-	214128Z	7	21 1/2	6 3/4	26	16	11	1 3/8	2 1/2	13 5/16	11 3/8	17 7/8	2 1/4	1/2	425.00
Cast Steel																
1 15/16	-	2K1431Z	1 3/4	6 1/2	1 3/4	8 1/4	4	3 1/2	1/2	7/8	3 7/16	3	4 1/2	3/4	1/4	11.00
2 3/16	-	2K1435Z	1 7/8	6 3/4	1 3/4	8 1/2	4 1/2	3 1/2	1/2	1	3 3/4	3 3/8	4 15/16	3/4	3/8	15.00
2 7/16	-	2K1439Z	2 1/8	8	2	10 1/4	5	4	5/8	1 1/8	4 3/16	3 3/4	5 3/8	1	3/8	21.00
2 11/16	-	2K1443Z	2 1/4	8 1/4	2 1/4	10 1/2	5 1/2	4 1/4	5/8	1 1/4	4 1/2	4	6	1	3/8	28.30
2 15/16	-	2K1447Z	2 1/2	8 3/4	2 1/2	11	6	4 1/2	5/8	1 3/8	4 7/8	4 1/4	6 7/8	1	3/8	34.00
3 7/16	-	2K1455Z	3 1/4	10 1/2	2 3/4	13	7	5	3/4	1 3/8	6 1/4	5 1/4	8 9/32	1 1/4	1/2	49.00
3 15/16	-	2K1463Z	3 1/2	12	3	14 3/4	8	5 1/2	3/4	1 1/2	6 13/16	5 7/8	9 13/16	1 3/8	1/2	69.00
4 7/16	-	2K1471Z	4 1/8	13 1/2	3 1/2	16 1/2	9	6 1/4	7/8	1 3/4	7 7/8	6 5/8	10 1/4	1 1/2	1/2	104.00
4 15/16	-	2K1479Z	4 1/2	15	4	18	10	7	7/8	1 7/8	8 9/16	7 1/4	11 3/16	1 5/8	1/2	134.00
5 7/16	-	2K1487Z	5	15 3/4	4 1/2	19 1/4	11	7 3/4	1	2	9 3/8	7 7/8	12 1/4	1 3/4	1/2	187.00
5 15/16	-	2K1495Z	5 1/2	16 1/2	5	20 1/2	12	8 1/2	1 1/8	2 1/8	10 1/4	8 1/2	13 7/8	1 7/8	1/2	213.00
6 1/2	-	2K14104Z	6	18	5 1/2	22	13	9 1/2	1 1/8	2 1/4	11	9 1/8	15 1/8	1 7/8	1/2	287.00
7	-	-	6 1/2	19	6	23	14	10	1 1/4	2 3/8	11 3/4	9 3/4	15 7/8	2	1/2	350.00
8	-	2K14128Z	7	21 1/2	6 3/4	26	16	11	1 3/8	2 1/2	13 5/16	11 3/8	17 7/8	2 1/4	1/2	478.00
9	-	2K14144Z	8	23	6	29	16	10 1/2	1 1/2	2 3/4	14 7/8	12 1/2	20 3/8	2 3/4	1/2	530.00
10	-	2K14160Z	9	25	6	31	16	10 1/2	1 3/4	3	16 7/8	14	22 7/8	3	1/2	650.00
12	-	2K14192Z	11	29	7 1/2	36	18	12 1/2	2	3 1/2	20	16	27	3 1/2	1/2	910.00

Additional Notes

- Please call 1-866-REXNORD for availability
- One pipe tapped hole (two holes for shafts larger than 5 in for lubrication)
- Grease cup or fitting not included
- LHD sliding base take-up can be drilled for these pillow blocks
- For the Selection Guide, Load Ratings and Speed Limits, see the Link-Belt Sleeve Bearing Engineering section on pages 534 - 537.
- Note: Dimensions subject to change. Certified dimensions of ordered material furnished on request.

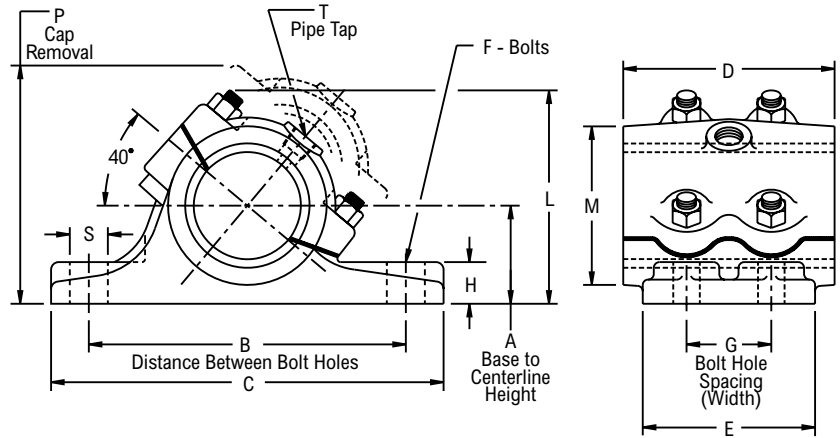
21500, 21500Z



Photo Shows a 4-Bolt Rigid Sleeve Bearing Two-Piece Pillow Block Unit with Bronze Bushing

Product Features

- Corrosion-resistant powder coating
- Cast iron housing
- Two-piece angular joint design
- Babbitt or Bronze sleeve
- 4-bolt base
- Relubricatable
- See Features and Benefits for additional info on page 532.



Bearing Dimensions

Shaft Diameter	Babbitt	Bronze	A Base to Centerline Height	B Distance Between Bolt Holes	G Bolt Hole Spacing (Width)	C	D	E	F	H	L	M	P	S	T	Approx. Weight
	Part Number	Part Number														
1 15/16	21531	21531Z	2 1/4	6 1/2	1 3/4	8 1/4	4	3 1/2	1/2	7/8	4 1/2	3	5 1/4	3/4	1/4	10.00
2 3/16	21535	21535Z	2 1/2	6 3/4	1 3/4	8 1/2	4 1/2	3 1/2	1/2	1	4 7/8	3 3/8	5 3/4	3/4	3/8	14.00
2 7/16	21539	21539Z	2 3/4	8	2	10 1/4	5	4	5/8	1 1/8	5 5/16	3 3/4	6 1/8	1	3/8	17.00
2 11/16	21543	21543Z	3	8 1/4	2 1/4	10 1/2	5 1/2	4 1/4	5/8	1 1/4	6	4	7	1	3/8	27.00
2 15/16	21547	21547Z	3 1/4	8 3/4	2 1/2	11	6	4 1/2	5/8	1 3/8	6 3/8	4 1/4	7 1/2	1	3/8	29.00
3 7/16	21555	21555Z	3 1/2	10 1/2	2 3/4	13	7	5	3/4	1 1/2	7 1/8	5 1/4	9	1 1/4	1/2	43.00
3 15/16	21563	21563Z	3 3/4	12	3	14 3/4	8	5 1/2	3/4	1 5/8	8 1/4	5 7/8	10 1/4	1 3/8	1/2	60.00
4 7/16	21571	21571Z	4 1/8	13 1/2	3 1/2	16 1/2	9	6 1/4	7/8	1 3/4	8 7/8	6 5/8	11	1 1/2	1/2	87.00
4 15/16	21579	21579Z	4 1/2	15	4	18	10	7	7/8	1 7/8	9 3/4	7 1/4	12	1 5/8	1/2	119.00
5 7/16	21587	21587Z	5	15 3/4	4 1/2	19 3/4	11	8	1	2	10 13/16	7 7/8	13 1/2	1 7/8	1/2	163.00
5 15/16	21595	21595Z	5 1/2	16 1/2	5	20 1/2	12	8 1/2	1 1/8	2 1/8	11 29/32	8 1/2	14 5/8	1 7/8	1/2	192.00
6 1/2	215104	215104Z	6	18	5 1/2	22	13	9 1/2	1 1/8	2 1/4	11 3/4	9 1/8	14 3/4	1 7/8	1/2	255.00
7	215112	215112Z	6 1/2	19	6	23	14	10	1 1/4	2 3/8	13 11/16	9 3/4	16 5/8	2	1/2	295.00
8	215128	215128Z	8	23	6	29	16	10 1/2	1 1/2	2 3/4	16 1/8	12 1/2	22	2 3/4	1/2	575.00

Additional Notes

- Please call 1-866-REXNORD for availability
- One pipe tapped hole (two holes for shafts larger than 5 in for lubrication)
- Grease cup or fitting not included
- For the Selection Guide, Load Ratings and Speed Limits, see the Link-Belt Sleeve Bearing Engineering section on pages 534 - 537.
- Note: Dimensions subject to change. Certified dimensions of ordered material furnished on request.

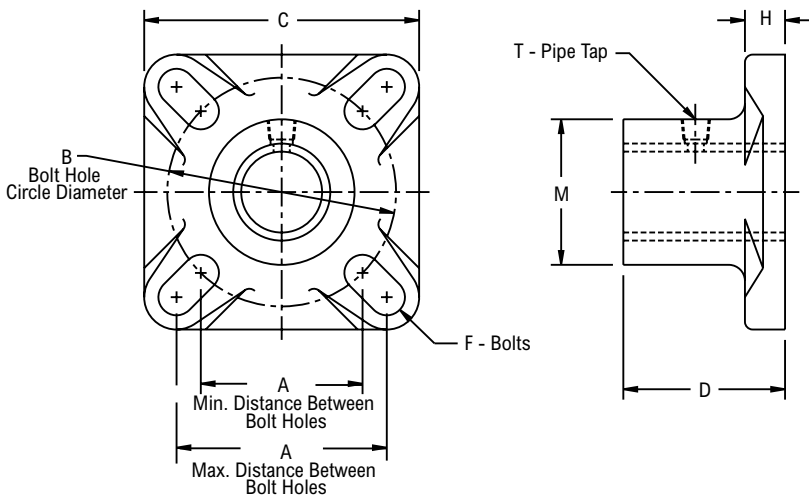
F2200, F2200Z



Photo Shows a 4-Bolt Rigid Sleeve Bearing Flanged Unit with Bronze Bushing

Product Features

- Corrosion-resistant powder coating
- Cast iron one piece housing
- Babbitt or Bronze sleeve
- Relubricatable
- See Features and Benefits for additional info on page 532.



Bearing Dimensions

Shaft Diameter	Babbitt	Bronze	A Min. Distance Between Bolt Holes	A Max. Distance Between Bolt Holes	B Bolt Hole Circle Diameter	C	D	F	H	M	T	Approx. Weight
	Part Number	Part Number										
3/4	F2212	F2212Z	2 1/8	2 1/2	3	3 3/8	1 1/2	3/8	7/16	1 1/2	1/8	1.70
7/8	F2214	F2214Z	2 1/8	2 3/4	3	3 3/4	2	3/8	1/2	1 7/8	1/8	2.50
1 5/16	F2215	F2215Z										
1	F2216	F2216Z	2 1/2	3 1/4	3 9/16	4 1/4	2 1/2	1/2	5/8	2 1/4	1/8	2.40
1 3/16	F2219	F2219Z										
1 1/4	F2220	F2220Z	2 29/32	4	4 1/8	5 1/8	3	1/2	3/4	2 1/2	1/4	3.70
1 7/16	F2223	F2223Z										
1 1/2	F2224	F2224Z	3 9/32	4 1/8	4 5/8	5 3/8	3 1/2	1/2	3/4	2 7/8	1/4	4.80
1 11/16	F2227	F2227Z										
1 3/4	F2228	F2228Z	3 23/32	5 1/8	5 1/4	6 3/8	4	5/8	7/8	3 1/4	1/4	10.40
1 15/16	F2231	F2231Z										
2	F2232	F2232Z	4 1/16	5 1/8	5 3/4	6 3/8	4 1/2	5/8	7/8	3 5/8	1/4	10.30
2 3/16	F2235	F2235Z										
2 7/16	F2239	F2239Z	4 13/32	5 5/8	6 1/4	6 7/8	5	5/8	1	4	3/8	14.80
2 15/16	F2247	F2247Z	5 7/32	6	7 3/8	7 3/4	6	3/4	1 1/8	4 3/4	3/8	16.50
3	F2248	F2248Z										
3 7/16	F2255	F2255Z	5 29/32	6 3/4	8 3/8	8 9/16	7	3/4	1 1/4	5 1/2	1/2	27.00
3 15/16	F2263	F2263Z	6 23/32	7 5/8	9 1/2	9 3/4	8	7/8	1 1/2	6 3/8	1/2	26.30
												40.50
												65.00

Additional Notes

- Please call 1-866-REXNORD for availability
- One pipe tapped hole for lubrication
- Grease cup or fitting not included
- For the Selection Guide, Load Ratings and Speed Limits, see the Link-Belt Sleeve Bearing Engineering section on pages 534 - 537.
- Note: Dimensions subject to change. Certified dimensions of ordered material furnished on request.

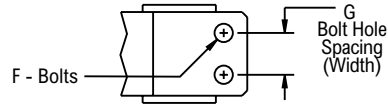
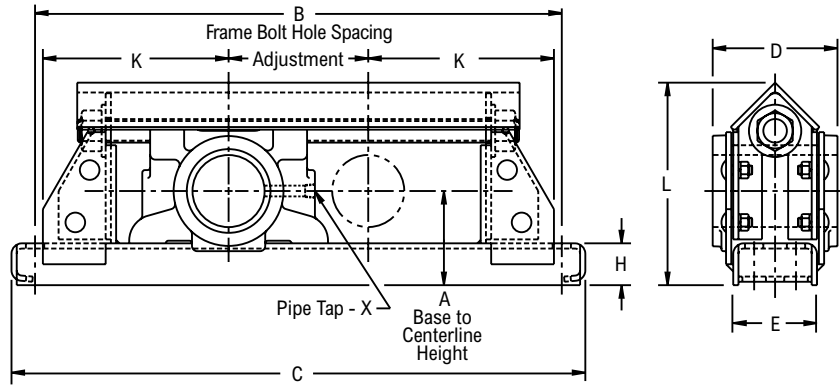
DSB2800



Photo Shows a Heavy Duty Removable Top Conveyor Take-up Frame with Rigid Sleeve Bearing Take-up Unit

Product Features

- Protected screw type frame
- Corrosion-resistant powder coating
- Cast iron housing
- Babbitt sleeve
- Relubricatable
- See Features and Benefits for additional info on page 532.



Bearing Dimensions

Shaft Diameter	Adjust.	Part Number	A Base to Centerline Height	B Frame Bolt Hole Spacing	G Bolt Hole Spacing (Width)	C	D	E	F	H	K	L	X	Radial Factor	Approx. Weight
1 15/16	12	DSB283112	3 1/4	26 1/2	-	29 1/2	4	3	5/8	1 3/4	7 3/4	7 1/4	1/4	1	39.00
	18	DSB283118		32 1/2		35 1/2									45.00
2 3/16	12	DSB283512	3 3/8	27 1/2	-	29 1/2	4	3	5/8	1 3/4	7 3/4	7 1/4	3/8	1	42.00
	18	DSB283518		33 1/2		35 1/2									48.00
2 7/16	12	DSB283912	3 1/2	28 1/2	-	30 1/2	5	3	3/4	1 3/4	8 1/4	7 1/2	3/8	1	49.00
	18	DSB283918		34 1/2		36 1/2									55.00
	24	DSB283924		40 1/2		42 1/2									60.00
2 15/16	12	DSB284712	4 1/8	30 1/2	2	32 1/2	6	4	5/8	2	9 1/4	8 3/4	3/8	1	72.00
	18	DSB284718		36 1/2		38 1/2									81.00
	24	DSB284724		42 1/2		44 1/2									89.00
3 7/16	12	DSB285512	4 1/2	32	2	34 1/4	7	4	3/4	2	10	9 11/16	1/2	1	94.00
	18	DSB285518		38		40 1/4									103.00
	24	DSB285524		44		46 1/4									111.00
3 15/16	12	DSB286312	5	36	2 1/2	38 1/2	8	5	3/4	2 1/4	12	10 15/16	1/2	1	138.00
	18	DSB286318		42		44 1/2									150.00
	24	DSB286324		48		50 1/2									160.00

Additional Notes

- Please call 1-866-REXNORD for availability
- One pipe tapped hole for lubrication
- Grease cup or fitting not included
- For replacement bearing unit, specify take-up number without amount of adjustment, i.e. DSB2831
- Take-ups with adjustment of 18 in (457.2 mm) or more have center supporting pad welded to bottom of frame
- For radial loads, multiply load rating by a factor of 1.0

For the Selection Guide, Load Ratings and Speed Limits, see the Link-Belt Sleeve Bearing Engineering section on pages 534 - 537.

Note: Dimensions subject to change. Certified dimensions of ordered material furnished on request.

Rigid Sleeve Bearing Replacement Parts



Bushings

1000Z Part Numbers

Shaft Diameter	Pillow Block	Replacement Bushing
	Part Number	Part Number
1/2	1008Z	285Y222101
5/8	1010Z	285Y222104
3/4	1012Z	285Y222105
7/8	1014Z	285Y2221
15/16	1015Z	285Y2222
1	1016Z	285Y2223
1 1/8	1018Z	285Y2224
1 3/16	1019Z	285Y2225
1 1/4	1020Z	285Y2226
1 3/8	1022Z	285Y2228
1 7/16	1023Z	285Y2229
1 1/2	1024Z	285Y22210
1 11/16	1027Z	285Y22211
1 3/4	1028Z	285Y22212
1 15/16	1031Z	285Y22213
2	1032Z	285Y22214
2 3/16	1035Z	285Y22215
2 7/16	1039Z	285Y22217
2 15/16	1047Z	285Y22223
3 7/16	1055FZ	285Y22225
3 15/16	1063FZ	285Y22227

F2200Z Part Numbers

Shaft Diameter	Flange Block	Replacement Bushing
	Part Number	Part Number
3/4	F2212Z	285Y22296
7/8	F2214Z	285Y2221
15/16	F2215Z	285Y2222
1	F2216Z	285Y2223
1 3/16	F2219Z	285Y2225
1 1/4	F2220Z	285Y2226
1 7/16	F2223Z	285Y2229
1 1/2	F2224Z	285Y22210
1 11/16	F2227Z	285Y22211
1 3/4	F2228Z	285Y22212
1 15/16	F2231Z	285Y22213
2	F2232Z	285Y22214
2 3/16	F2235Z	285Y22215
2 7/16	F2239Z	285Y22217
2 15/16	F2247Z	285Y22223
3	F2248Z	285Y22224
3 7/16	F2255Z	285Y22225
3 15/16	F2263Z	285Y22227

Additional Notes

Bronze replacement bearings are sold with lube groove. Provision should be made to lock the bearing to the housing.

Rigid Sleeve Bearing Replacement Parts



Bushing



Shims

21200Z Part Numbers

Shaft Diameter	Pillow Block	Replacement Bushing	Shims	
	Part Number		Part Number	Part Number
7/8	21214Z	285BY24	131Y9541	2
15/16	21215Z	285BY25	131Y95421	2
1	21216Z	285BY26	131Y95421	2
1 1/16	21217Z	285BY215	131Y95424	2
1 1/8	21218Z	285BY27	131Y9542	2
1 3/16	21219Z	285BY28	131Y95422	2
1 1/4	21220Z	285BY29	131Y95422	2
1 3/8	21222Z	285BY210	131Y95423	4
1 7/16	21223Z	285BY211	131Y95423	4
1 1/2	21224Z	285BY212	131Y95423	4
1 9/16	21225Z	285BY213	131Y95424	4
1 5/8	21226Z	285BY214	131Y95424	4
1 11/16	21227Z	285BY215	131Y95424	4
1 3/4	21228Z	285BY216	131Y95424	4
1 15/16	21231Z	285BY217	131Y95425	4
2	21232Z	285BY218	131Y95425	4
2 3/16	21235Z	285BY219	131Y95426	4
2 1/4	21236Z	285BY220	131Y95426	4
2 7/16	21239Z	285BY222	131Y95427	4
2 1/2	21240Z	285BY224	131Y95427	4
2 11/16	21243Z	285BY225	131Y95428	4
2 15/16	21247Z	285BY229	131Y95429	4
3	21248Z	285BY230	131Y95429	4
3 7/16	21255Z	285BY232	131Y95430	4
3 15/16	21263Z	285BY236	131Y95431	4

21400Z, 2K1400Z Part Numbers

Shaft Diameter	Pillow Block	Replacement Bushing	Shims	
	Part Number		Part Number	Part Number
1 15/16	21431Z, 2K1431Z	285BY31	131Y3661	4
2 3/16	21435Z, 2K1435Z	285BY33	131Y3663	4
2 7/16	21439Z, 2K1439Z	285BY37	131Y3665	4
2 11/16	21443Z, 2K1443Z	285BY39	131Y3667	4
2 15/16	21447Z, 2K1447Z	285BY313	131Y3669	4
3 7/16	21455Z, 2K1455Z	285BY317	131Y36611	6
3 15/16	21463Z, 2K1463Z	285BY319	131Y36613	6
4 7/16	21471Z	285BY321	131Y36615	8
4 7/16	2K1471Z	285BY322	131Y36615	8
4 15/16	21479Z	285BY325	131Y36617	8
4 15/16	2K1479Z	285BY326	131Y36617	8
5 7/16	21487Z, 2K1487Z	285BY329	131Y36618	12
5 15/16	21495Z, 2K1495Z	285BY331	131Y36621	12
6 7/16	214103Z, 2K14103Z	285BY333	131Y36622	12
6 1/2	214104Z, 2K14104Z	285BY334	131Y36622	12
7	214112Z, 2K14112Z	285BY335	131Y36625	12
7 1/2	214120Z, 2K14120Z	285BY336	131Y36628	12
8	214128Z, 2K14128Z	285BY337	131Y36630	12
9	2K14144Z	285BY338	131Y36620	2
10	2K14160Z	285BY340	131Y36624	2
12	2K14192Z	285BY341	131Y36626	2

Additional Notes

Replacement bronze bearings are pre-split with lube groove. Provision should be made to lock each bearing segment to the base and cap. Replacement bronze bearings and shims must be ordered as individual items.

Rigid Sleeve Bearing Replacement Parts



Bushing



Shims

21500Z Part Numbers

Shaft Diameter	Pillow Block	Replacement Bushing	Shims	
	Part Number	Part Number	Part Number	Quantity
1 ¹⁵ / ₁₆	21531Z	285BY217	131Y95425	4
2 ³ / ₁₆	21535Z	285BY219	131Y95426	4
2 ⁷ / ₁₆	21539Z	285BY222	131Y95427	4
2 ¹¹ / ₁₆	21543Z	285BY225	131Y95428	4
2 ¹⁵ / ₁₆	21547Z	285BY229	131Y95429	4
3 ⁷ / ₁₆	21555Z	285BY233	131Y9549	6
3 ¹⁵ / ₁₆	21563Z	285BY237	131Y95410	6
4 ⁷ / ₁₆	21571Z	285BY240	131Y95411	8
4 ¹⁵ / ₁₆	21579Z	285BY242	131Y95412	8
5 ⁷ / ₁₆	21587Z	285BY244	131Y95434	12
5 ¹⁵ / ₁₆	21595Z	285BY331	131Y36621	12
6 ¹ / ₂	215104Z	285BY334	131Y36622	12
7	215112Z	285BY335	131Y36625	12
8	215128Z	285BY337	131Y36616	2

Additional Notes

Replacement bronze bearings are pre-split with lube groove. Provision should be made to lock each bearing segment to the base and cap. Replacement bronze bearings and shims must be ordered as individual items.

Sleeve Bearings

Flex Block: Link-Belt



Contents

	Page
Features and Benefits	552
Nomenclature	553
Engineering	554
Dimensions	
Pillow Blocks	557
Flange Blocks	558
Take-up Frames	560

Industries Served

Commercial Furnaces
Heat Treatment
Wastewater Management
Dams
Air Handling



3200 Series Flex-block Sleeve Bearing Units

Flex-block Sleeve Bearings are alignable and self-lubricating. Because the bearing material wears gradually under operation, sudden breakdowns and costly maintenance are minimized. The standard bearing insert materials of oil impregnated porous sintered bronze, or self-lubricating graphite are widely used for the extreme applications of modern industry.



1. One-piece Housing

Sturdy one-piece housings, with machined mounting surfaces, are available as pillow blocks or flanged units.

2. Machined Surface

Component has machined spherical surface for proper seating in housing and for initial mounting alignment.

3. Self-Lubricating or Oil Impregnated

Bearing sleeve, pressed into component, is available in self-lubricating or oil impregnated material.

4. Extend Unit Life

When the component retaining screw is loosened, the insert can be rotated 180° to utilize unused bearing surface and extend the life of the unit.

Bearings Components

Heart of the flex-block bearing is the alignable insert into which is pressed a self-lubricating bearing. The component has a machined spherical surface that is alignable in the housing.

Two types of bearings are available:

1. Sintered bronze sleeve, oil impregnated, for operating temperatures to 200°F (93°C).
2. Self-lubricating carbon-graphite sleeve, for temperatures to 700°F (371°C).

One-piece Cast Iron Housings

Compact one-piece cast iron housings provide strength and superior rigidity. All units are designed with standard mounting dimensions and have finished mounting surfaces for proper installation stability. Pillow blocks have slotted bolt holes with ample space provided for drilling dowel pin holes. Flanged units have drilled mounting holes.

Pillow Blocks

3200P

Alignable pillow blocks have a high-test iron housing, 2-bolt base, and self-lubricating bearing. For shaft sizes 5/8" through 3 15/16".



Flanged Units - 2-bolt

3200FX

Alignable flanged units have 2-bolt cast iron housing and self-lubricating bearing. For shaft sizes 5/8" through 1 3/4".



Flanged Units - 4-bolt

3200F

Alignable flanged units have 4-bolt cast iron housing and self-lubricating bearing. For shaft sizes 5/8" through 3 7/16".



Nomenclature

Symbol	Description	32	16	F	T1	S	C
32	Standard duty series						
16	Shaft diameter in 16ths of an inch						
F	Flanged unit, 4-bolt						
FX	Flanged unit, 2-bolt						
P	Pillow block						
T1	Porous sintered bronze, oil impregnated, 200°F max.						
T3	Self-lubricating carbon graphite, 700°F max.						
T4	Plain bore (cast iron), 1000°F max.						
None	Standard length						
S	Short sleeve, (F, FX units)						
C	Closed end unit						

The nomenclature shown is provided to identify the basic and optional features of bearing and mounted unit assemblies. The most commonly specified variations are listed; however, availability of all variations cannot be assumed. Link-Belt Bearing Division, Rexnord Corporation should be consulted regarding optional features, availability, and the application requirements.

Flex-block Sleeve Bearing Selection Guide

To select a flex-block sleeve bearing, determine the applied radial load and the applicable operating conditions. The procedure shown here will aid in selecting an appropriate bearing.

The bearing ratings apply when certain installation and operating conditions are met and when any other adverse ambient conditions such as high or low temperatures, extreme dirt or moisture, chemical contamination, shock or vibration loading direct or induced, oscillating shafts, intermittent operation and related factors are carefully considered.

The ratings used apply when the following conditions are met:

1. Normal running loads should not exceed the ratings shown in the tables. Starting and occasional peak loads should not exceed these ratings by more than 100%.

2. The shaft finish through the bearing bore should be at least as smooth as commercial steel shafting which varies from 8 to 50 micro-inches ($0.2\ \mu\text{m}$ to $1.3\ \mu\text{m}$). There also should be no machined or ground spiral lead on the shaft journal. For improved bearing performance the shaft finish should not exceed 12 micro-inches ($0.3\ \mu\text{m}$). Shafting should also be within the diameter tolerances.
3. Ambient temperatures should not be lower than 32°F (0°C) for T1 bearing material. The upper operating temperature limits are as follows: T1—200°F (93°C) T3—700°F (371°C)
4. Sturdy, vibration free supporting structures should be provided.
5. Flex-block units should not be exposed to severe dirt conditions.

Steps for Selection

Step 1

Determine the maximum operating temperature of the application.

Step 2

From Table 1, select the bearing insert material.

Step 3

Refer to the radial load rating tables to determine the shaft diameter necessary to obtain the required radial load rating at the given speed. Where short bearings are required, multiply the radial load by the short bearing factor before selecting the bearing.

Step 4

To position a shaft axially or where light thrust loads are present, provide flat washers of the desired material backed by a shaft collar or a machined shaft shoulder against the end of the bearing. The bearing ends are already machined.

Table 1 – Bearing insert material selection

Bearing Insert Suffix	Bearing material	Type of Lubrication	Type of Unit	Available Bore size
T1	Oil impregnated porous sintered bronze	Oil	P	5/8" – 3 15/16"
			FX	5/8" – 1 3/4"
			F	5/8" – 3 7/16"
T3	Machined carbon-graphite	Self-lubricating	P	5/8" – 3 15/16"
			FX	5/8" – 1 3/4"
			F	5/8" – 3 7/16"

Bearing Insert Suffix	Minimum Temperature Limit	Maximum Temperature Limit	Comments
T1	32°F (0°C)	200°F (93°C)	
T3	...	700°F (371°C)	material somewhat brittle—handle with care—no significant shock loads

Additional Information

Flex-block Bearing Materials:

Sleeve bearing inserts made of T1 oil impregnated porous sintered bronze are universally accepted as providing reasonable capacity and dependable service. When lubricant is present damage to shafts or rotors is minimized. Additional SAE 40 oil can be periodically added to extend the bearing life. The T1 bearing operating temperature should not exceed 200°F (93°C). Applications are restricted to those involving light to moderate loads and mild shock. Caution: Do not use stainless steel shaft.

T3 machined carbon graphite bearings are self-lubricating with material worn from the bearing. T3 bearing inserts are limited to a maximum operating temperature of 700°F (371°C). The radial load applied, the shaft surface finish and the speed of operation determine the wear life of the bearing. As machined carbon graphite is somewhat brittle, care should be taken during handling and mounting to avoid chipping the corners, etc.

Additional Features:

By the very nature of their design all flex-block sleeve bearing units are expansion type, in that the shaft journal is free to move axially through the bore of the bearing. To fix a unit, a combination of shaft shoulders and/or thrust collars with flat washers of the desired material can be utilized.

Flex-block pillow blocks have cored mounting bolt holes suitable for the inch or metric bolts listed. Flanged units have drilled mounting holes 1/32" ($0.8\ \text{mm}$) larger than the largest inch bolt shown.

Bearings are not replaceable in the components. Replacement components can be ordered but generally the entire unit is replaced when required.

2 and 4-bolt flanged units can be supplied with regular or short bearings.

The short bearing inserts do not project beyond the housing mounting face. When the short bearing is selected, the applied radial load must be multiplied by the short bearing factor before selecting the bearing size.

End closures can be furnished but they require specially machined housings. When end closures are used, shafts should extend no more than 1/8" ($3.2\ \text{mm}$) beyond the end of the bearing.

Operation:

Flex-block sleeve bearing units are self-lubricating and ready for operation. Being alignable, they are also easy to mount and careful shaft alignment is not required. However shaft journals must turn freely without binding in the bearing or excessive heat and seizure can result. Any factors which may disrupt or remove the lubricant film should be eliminated. Sharp edges on the shaft or the bearing surface can act as scrapers to destroy lubricant film. Do not extend shaft keyways into bearing bores.

Take-ups:

Flex-block pillow blocks can be mounted on universal take-up frames LC.

Shaft Tolerances:

Shaft diameters for flex-block sleeve bearing units are usually held to the following regular commercial tolerances:

Shaft Diameters Recommended Tolerance

5/8" through 2"	Nominal to $-.003$ "
2 1/2" through 4"	Nominal to $-.004$ "

Caution: Do not use stainless steel shaft, if bearing insert T1 is used.

Commercial shaft finish if free of nicks, burrs, scratches, etc. is generally satisfactory. Improved surface finish of 12 micro-inches ($0.3\ \mu\text{m}$) or less will extend wear life.

Warning

The reliability built in all Rexnord bearings can be realized in service only when bearings are correctly selected, properly installed, protected and maintained.

The correct selection of flex-block sleeve bearing mounted units requires that the magnitude and nature of all loads, speeds, alignment, mounting, operating requirements and maintenance be adequately considered. The selection of materials for and design of shafting, fasteners, seals and accessories as well as provisions for installation and maintenance must follow good engineering principles.

Housings should not be used under tension loads except with adequate safety factors. For this reason pillow blocks are best suited to withstand radial loads passing through the base. When heavy loads or shock loads are possible it is most important to mount a unit so that the line of force passes directly into the mounting surface, or so that the unit is directly and substantially supported other than through its mounting bolts. Where the line of force falls outside the mounting surface, serious housing and fastener deflection or failure may occur. Rexnord Bearing Division should be consulted where unusual loading conditions exist.

Radial Load Ratings for 10 to 300 RPM (pounds/newtons)*

Shaft Diameter Inches	Basic Bearing Number	Type Bearing Material	Shaft Speed RPM												Short Bearing Factor				
			10 to 25		50		75		100		150		200			300			
5/8	3210	T1 T3	586	2607	586	2607	586	2607	586	2607	476	2117	357	1588	238	1059	...		
11/16	3211		296	1317	296	1317	296	1317	296	1317	240	1068	180	801	120	534			
3/4	3212	T1 T3	940	4181	940	4181	940	4181	940	4181	638	2838	479	2131	318	1415	1.25		
			470	2091	470	2091	470	2091	470	2091	318	1415	240	1068	159	707			
7/8	3214	T1 T3	985	4381	985	4381	985	4381	860	3825	572	2544	430	1913	286	1272	...		
15/16	3215		493	2193	493	2193	493	2193	430	1913	287	1277	215	956	144	641			
1	3216																		
1 1/8	3218	T1 T3	1545	6870	1545	6870	1400	6230	1050	4670	701	3118	527	2344	350	1557	1.22		
1 3/16	3219		773	3438	773	3438	700	3114	526	2340	350	1557	262	1165	175	778			
1 1/4	3220	T1 T3	2110	9390	985	4381	1720	7650	1295	5760	862	3834	650	2891	433	1926	1.42		
1 15/16	3221		1055	4690	493	2193	860	3825	646	2874	430	1913	323	1437	215	956			
1 3/8	3222																		
1 7/16	3223																		
1 1/2	3224	T1 T3	3190	14900	3190	14190	2160	9610	1630	7250	1090	4850	815	3625	545	2424	1.54		
			1595	7100	1595	7100	1080	4800	812	3612	543	2415	406	1806	272	1210			
1 5/8	3226	T1 T3	3450	15350	3240	14410	2160	9610	1620	7210	1090	4850	815	3625	545	2424	1.41		
1 11/16	3227		1725	7670	1620	7210	1080	4800	812	3612	543	2415	406	1806	272	1210			
1 3/4	3228																		
1 15/16	3231	T1 T3	4360	19390	3440	15300	2340	10410	1720	7650	1150	5120	860	3825	575	2558	1.39		
			2180	9700	1720	7650	1170	5200	860	3825	575	2558	430	1913	288	1281			
2	3232	T1 T3	4750	21130	3620	16100	2420	10760	1810	8050	1210	5380	910	4048	608	2705	1.47		
2 1/8	3234		2375	10560	1810	8050	1210	5380	908	4039	606	2696	454	2019	303	1348			
2 3/16	3235																		
2 1/4	3236	T1 T3	6050	26910	4110	18280	2750	12200	2050	9120	1370	6090	1030	4580	687	3056	1.45		
2 7/16	3239		3025	13460	2052	9130	1375	6120	1026	4560	686	3051	513	2282	343	1526			
2 1/2	3240	T1 T3	7500	33360	4590	20420	3050	13570	2290	10190	1530	6810	1145	5090	765	3403	1.51		
2 11/16	3243		3750	16680	2290	10190	1530	6810	1145	5090	764	3398	573	2549	382	1699			
2 3/4	3244	T1 T3	9120	40570	5070	22550	3380	15030	2530	11250	1685	7500	1265	5630	844	3754	1.61		
2 15/16	3247		4560	20280	2532	11260	1690	7510	1266	5630	845	3759	633	2816	423	1882			
3 7/16	3255	T1 T3	11500	51150	5720	25440	3820	16990	2880	12810	1925	8560	1440	6410	965	4293	1.31		
			5710	25410	2860	12720	1910	8500	1440	6410	963	4284	720	3203	483	2148			
3 15/16	3263	T1 T3	15000	66720	7500	33360	5000	22240	3730	16590	2500	11120	1870	8320	1248	5550	...		
			7520	33450	3750	16680	2500	11120	1865	8300	1250	5560	935	4159	625	2780			

* For speeds slower than 10 RPM or for oscillating shafts, consult Rexnord Bearing Division

Radial Load Ratings for 400 to 2500 RPM (pounds/newtons)*

Shaft Diameter Inches	Basic Bearing Number	Type Bearing Material	Shaft Speed RPM												Short Bearing Factor			
			400		500		750		1000		1500		2000			2500		
5/8	3210	{T1	180	801	144	641	96	427	71	316	48	214	36	160	29	129	...	
11/16	3211	T3	90	400	72	320	48	214	36	160	24	107	24	80	15	67		
3/4	3212	{T1	238	1059	191	850	128	569	96	427	64	285	48	214	38	169	1.25	
		T3	120	534	92	409	63	280	48	214	32	142	24	107	19	84		
7/8	3214	{T1	215	956	175	778	114	507	86	383	57	254	43	191	34	151	
15/16	3215	T3	108	480	86	383	57	254	43	191	29	129	22	98		
1	3216																1.22	
1 1/8	3218	{T1	263	1170	211	939	140	623	105	467	70	311	53	236	42	187		
1 3/16	3219	T3	131	583	105	467	70	311	53	236	35	156		
1 1/4	3220	{T1	322	1432	258	1148	172	765	130	578	86	383	65	289	52	231	1.42	
1 15/16	3221																	
1 3/8	3222		T3	162	721	130	578	86	383	65	289	43	191
1 7/16	3223																	
1 1/2	3224	{T1	408	1815	325	1446	216	961	163	725	109	485	82	365	65	289	1.54	
		T3	203	903	162	721	109	485	81	360		
1 5/8	3226	{T1	408	1815	325	1446	216	961	162	725	109	485	82	365			1.42	
1 11/16	3227		T3	203	903	162	721	109	485	81	360			
1 3/4	3228																	
1 15/16	3231	{T1	431	1917	344	1530	234	1041	172	765	115	512					1.39	
		T3	215	956	172	765	115	512						
2	3232	{T1	455	2024	363	1615	242	1076	181	805	125	556					1.47	
2 1/8	3234		T3	227	1010	182	810	121	538					
2 3/16	3235																	
2 1/4	3236	{T1	515	2291	413	1837	275	1223	205	912	137	609					1.45	
2 7/16	3239		T3	257	1143	205	912	137	609					
2 1/2	3240	{T1	574	2553	460	2046	305	1357	229	1019							1.51	
2 11/16	3243		T3	287	1277	229	1019	153	681					
2 3/4	3244	{T1	635	2825	507	2255	338	1503	253	1125							1.61	
2 15/16	3247		T3	317	1410	253	1125							
3 7/16	3255	{T1	725	3225	580	2580	382	1699	290	1390						1.31		
		T3	363	1615	290	1290								
3 15/16	3263	{T1	936	4164	750	3336	500	2224								...		
		T3	468	2082										

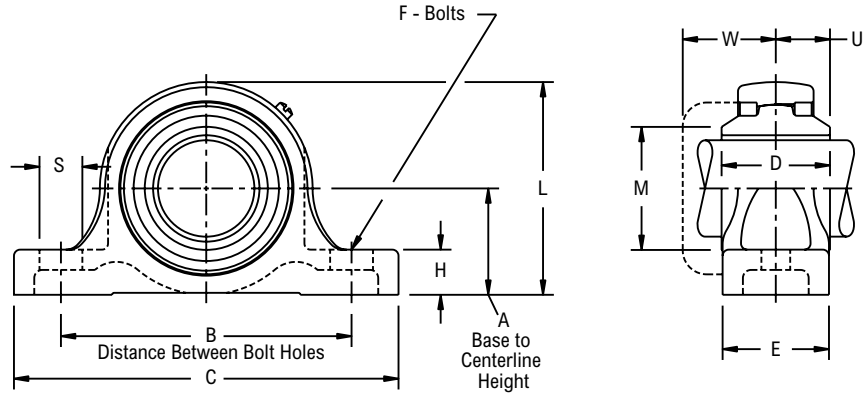
* Load ratings are based on industry standards established by the Mechanical Power Transmission Association.



Photo Shows a 2-Bolt Flex Block Sleeve Bearing Pillow Block Unit with Bronze Bushing

Product Features

- Corrosion-resistant powder coating
- Cast iron housing
- T1 sintered bronze sleeve
- T3 carbon graphite sleeve
- 2-bolt base
- Alignable
- See Features and Benefits for additional info on page 552.



Bearing Dimensions

Shaft Diameter	Carbon Graphite Self-Lubricating	Porous Sintered Bronze Oil Impregnated	A Base to Centerline Height	B Distance Between Bolt Holes	C	D	E	F	H	L	M	S	U	W	Approx. Weight												
	Part Number	Part Number																									
5/8	3210PT3	3210PT1	1 3/16	3 1/2	4 5/8	15/16	1 1/2	3/8	1/2	2 11/32	1 1/8	3/4	15/32	1 13/64	1.30												
11/16	3211PT3	3211PT1													1.20												
3/4	3212PT3	3212PT1	1 5/16	3 7/8	5 1/8	1 1/4	1 1/2	3/8	1/2	2 19/32	1 3/16	11/16	5/8	1 19/64	1.80												
7/8	3214PT3	3214PT1													2.10												
15/16	3215PT3	3215PT1	1 7/16	4	5 3/8	1 1/8	1 5/8	3/8	9/16	2 7/8	1 9/16	11/16	9/16	1 9/32	2.00												
1	3216PT3	3216PT1													1.90												
1 1/8	3218PT3	3218PT1	1 11/16	4 5/8	6 3/16	1 3/8	1 3/4	1/2	11/16	3 5/16	1 7/8	15/16	11/16	1 29/64	2.80												
1 3/16	3219PT3	3219PT1													2.70												
1 1/4	3220PT3	3220PT1	1 7/8	4 15/16	6 3/8	1 11/16	1 7/8	1/2	13/16	3 11/16	2 1/8	13/16	27/32	1 35/64	4.50												
1 5/16	3221PT3	3221PT1													4.40												
1 3/8	3222PT3	3222PT1													4.30												
1 7/16	3223PT3	3223PT1													4.10												
1 1/2	3224PT3	3224PT1													2	5 3/8	7 1/16	2 1/8	1 7/8	1/2	13/16	4	2 1/8	15/16	1 1/16	1 41/64	5.30
1 5/8	3226PT3	3226PT1																									6.40
1 11/16	3227PT3	3227PT1	2 1/8	5 5/8	7 1/4	2 1/8	2	1/2	13/16	4 5/16	2 7/16	7/8	1 1/16	1 21/32	6.30												
1 3/4	3228PT3	3228PT1													6.10												
1 15/16	3231PT3	3231PT1	2 1/4	6 3/16	7 7/8	2 1/4	2 1/8	5/8	7/8	4 1/2	2 9/16	15/16	1 1/8	1 25/32	7.20												
2	3232PT3	3232PT1													9.20												
2 1/8	3234PT3	3234PT1	2 1/2	6 3/4	9 1/16	2 3/8	2 3/8	5/8	1	5	2 7/8	1 5/16	1 3/16	2 1/64	9.00												
2 3/16	3235PT3	3235PT1													8.80												
2 1/4	3236PT3	3236PT1	2 11/16	7 1/2	9 1/2	2 11/16	2 1/2	5/8	1 1/8	5 7/16	3 1/4	1 1/16	1 11/32	2 7/64	13.40												
2 7/16	3239PT3	3239PT1													13.20												
2 1/2	3240PT3	3240PT1	3	8 1/8	10 1/2	3	2 7/8	3/4	1 5/16	6	3 9/16	1 3/16	1 1/2	2 1/16	17.10												
2 11/16	3243PT3	3243PT1													16.50												
2 3/4	3244PT3	3244PT1	3 1/4	8 7/8	11 3/4	3 5/16	3 1/4	3/4	1 3/8	6 1/2	3 3/4	1 5/16	1 21/32	2 7/32	22.50												
2 15/16	3247PT3	3247PT1													21.90												
3 7/16	3255PT3	3255PT1	3 3/4	10	13	3 3/4	3 1/2	7/8	1 5/8	7 7/8	4 7/16	1 5/8	1 7/8	2 1/2	32.50												
3 15/16	3263PT3	3263PT1	4 7/16	11 7/8	15 1/4	4 15/16	4 3/8	7/8	1 13/16	8 15/16	4 7/8	1 7/8	2 15/32	3 1/64	59.70												

Additional Notes

- Please call 1-866-REXNORD for availability
- For replacement insert number, omit housing suffix designation, i.e. 3210T1
- For the Selection Guide, Load Ratings and Speed Limits, see the Link-Belt Flex-block Bearing Engineering section on pages 554 - 556.
- Note: Dimensions subject to change. Certified dimensions of ordered material furnished on request.

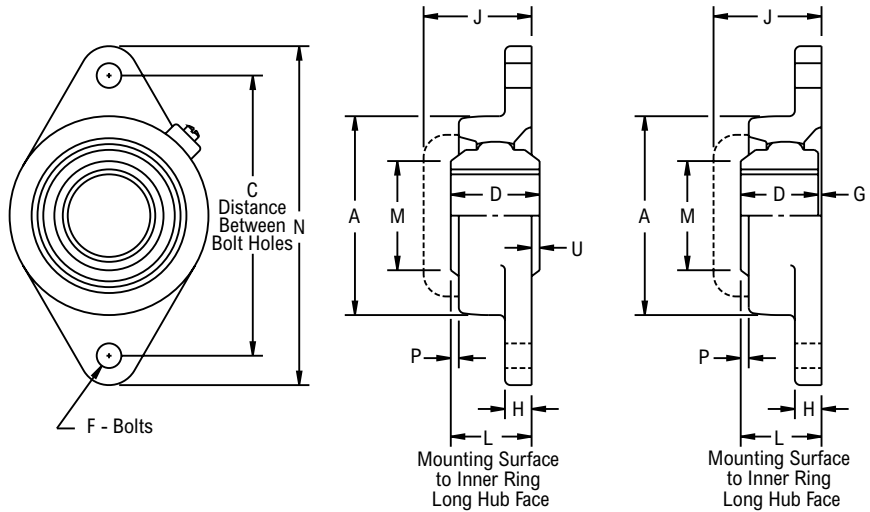
3200FX



Photo Shows a 2-Bolt Flex Block Sleeve Bearing Flanged Unit with Graphite Bushing

Product Features

- Corrosion-resistant powder coating
- Cast iron housing
- T1 sintered bronze sleeve
- T3 carbon graphite sleeve
- 2-bolt mounting
- Alignable
- See Features and Benefits for additional info on page 552.



Bearing Dimensions

Shaft Diameter	Carb on Graphite Self-Lubricating	Porous Sintered Bronze Oil Impregnated	C Distance Between Bolt Holes	L Mounting Surface to Inner Ring Long Hub Face	A	D Reg	D Short	F	G	H	J	M	N	P	U	Approx. Weight
	Part Number	Part Number														
5/8	3210FXT3	3210FXT1	3	1 7/64	2 1/8	15/16	-	3/8	17/64	1/2	1 25/32	1 1/8	3 7/8	7/64	-	1.00
11/16	3211FXT3	3211FXT1														0.90
3/4	3212FXT3	3212FXT1	3 17/32	1 23/64	2 7/16	1 1/4	1 1/8	3/8	1/4	9/16	2 1/64	1 3/16	4 13/32	5/32	-	1.20
7/8	3214FXT3	3214FXT1														1.70
15/16	3215FXT3	3215FXT1	3 57/64	1 5/16	2 11/16	1 1/8	-	7/16	3/16	19/32	2	1 9/16	4 29/32	1/16	-	1.60
1	3216FXT3	3216FXT1														1.50
1 1/8	3218FXT3	3218FXT1	4 19/32	1 15/32	3 3/16	1 3/8	1 1/4	7/16	7/32	19/32	2 15/64	1 7/8	5 19/32	5/32	-	2.50
1 3/16	3219FXT3	3219FXT1														2.30
1 1/4	3220FXT3	3220FXT1	5 1/8	1 21/32	3 5/8	1 11/16	1 1/2	1/2	5/32	5/8	2 23/64	2 1/8	6 1/8	1/4	1/32	3.70
1 5/16	3221FXT3	3221FXT1														3.60
1 3/8	3222FXT3	3222FXT1														3.50
1 7/16	3223FXT3	3223FXT1														3.30
1 1/2	3224FXT3	3224FXT1	5 21/32	1 31/32	4	2 1/8	1 3/4	1/2	5/32	5/8	2 35/64	2 1/8	6 25/32	25/64	5/32	4.90
1 5/8	3226FXT3	3226FXT1														6.20
1 11/16	3227FXT3	3227FXT1	5 27/32	1 31/32	4 1/4	2 1/8	1 13/16	1/2	5/32	5/8	2 9/16	2 7/16	7 3/32	3/8	5/32	6.00
1 3/4	3228FXT3	3228FXT1														5.90

Additional Notes

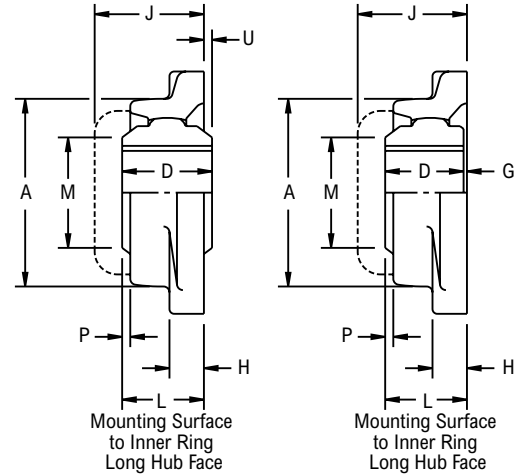
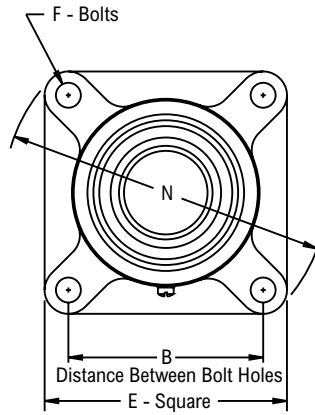
- Please call 1-866-REXNORD for availability
- For replacement insert number, omit housing suffix designation, i.e. 3210T1
- For short sleeves, add suffix "S", i.e. 3220FXT1S
- For the Selection Guide, Load Ratings and Speed Limits, see the Link-Belt Flex-block Bearing Engineering section on pages 554 - 556.
- Note: Dimensions subject to change. Certified dimensions of ordered material furnished on request.



Photo Shows a 4-Bolt Flex Block Sleeve Bearing Flanged Unit with Graphite Bushing

Product Features

- Corrosion-resistant powder coating
- Cast iron housing
- T1 sintered bronze sleeve
- T3 carbon graphite sleeve
- 4-bolt mounting
- Alignable
- See Features and Benefits for additional info on page 552.



Bearing Dimensions

Shaft Diameter	Carbon Graphite Self-Lubricating	Porous Sintered Bronze Oil Impregnated	B Distance Between Bolt Holes	L Mounting Surface to Inner Ring Long Hub Face	A	D Reg	D Short	E	F	G	H	J	M	N	P	U	Approx. Weight
	Part Number	Part Number															
5/8	3210FT3	3210FT1	2 1/8	1 7/64	2 1/8	15/16	-	3	3/8	17/64	1/2	1 25/32	1 1/8	3 7/8	7/64	-	1.20
11/16	3211FT3	3211FT1															1.10
3/4	3212FT3	3212FT1	2 1/2	1 23/64	2 7/16	1 1/4	1 1/8	3 3/8	3/8	1/4	9/16	2 1/64	1 3/16	4 13/32	5/32	-	1.50
7/8	3214FT3	3214FT1															2.10
15/16	3215FT3	3215FT1	2 3/4	1 5/16	2 11/16	1 1/8	-	3 3/4	7/16	3/16	19/32	2	1 9/16	4 29/32	1/16	-	2.00
1	3216FT3	3216FT1															1.90
1 1/8	3218FT3	3218FT1	3 1/4	1 15/32	3 3/16	1 3/8	1 1/4	4 1/4	7/16	7/32	19/32	2 15/64	1 7/8	5 19/32	5/32	-	3.20
1 3/16	3219FT3	3219FT1															2.90
1 1/4	3220FT3	3220FT1	3 5/8	1 21/32	3 5/8	1 11/16	1 1/2	4 5/8	1/2	5/32	5/8	2 23/64	2 1/8	6 1/8	1/4	1/32	4.50
1 5/16	3221FT3	3221FT1															4.40
1 3/8	3222FT3	3222FT1															4.30
1 7/16	3223FT3	3223FT1															4.10
1 1/2	3224FT3	3224FT1															5.60
1 5/8	3226FT3	3226FT1	4 1/8	1 31/32	4 1/4	2 1/8	1 13/16	5 3/8	1/2	5/32	5/8	2 9/16	2 7/16	7 3/32	3/8	5/32	7.10
1 11/16	3227FT3	3227FT1															6.80
1 3/4	3228FT3	3228FT1	4 3/8	2 5/32	4 1/2	2 1/4	1 15/16	5 5/8	1/2	7/32	3/4	2 13/16	2 9/16	7 7/16	27/64	3/32	6.70
1 15/16	3231FT3	3231FT1															7.80
2	3232FT3	3232FT1	5 1/8	2 11/32	4 15/16	2 3/8	2	6 3/8	5/8	11/32	29/32	3 11/64	2 7/8	8 1/2	13/32	1/32	10.00
2 1/8	3234FT3	3234FT1															9.80
2 3/16	3235FT3	3235FT1															9.50
2 1/4	3236FT3	3236FT1	5 5/8	2 5/8	5 3/8	2 11/16	2 1/4	6 7/8	5/8	3/8	15/16	3 25/64	3 1/4	9 7/32	27/64	1/16	12.80
2 7/16	3239FT3	3239FT1															12.60
2 1/2	3240FT3	3240FT1	5 7/8	2 19/32	5 7/8	3	2 1/2	7 3/8	5/8	3/32	3/4	3 5/32	3 9/16	9 13/16	7/16	13/32	16.60
2 11/16	3243FT3	3243FT1															15.90
2 3/4	3244FT3	3244FT1	6	2 13/16	6 3/8	3 5/16	2 11/16	7 3/4	3/4	1/8	3/4	3 3/8	3 3/4	10 1/4	17/32	1/2	20.40
2 15/16	3247FT3	3247FT1															19.80
3 7/16	3255FT3	3255FT1	6 3/4	3 13/32	7 1/2	3 3/4	3 5/16	8 9/16	3/4	3/32	1	4 1/32	4 7/16	11 3/8	1/2	11 1/32	29.50

Additional Notes

- Please call 1-866-REXNORD for availability
- For replacement insert number, omit housing suffix designation, i.e. 3210T1
- For short sleeves, add suffix "S", i.e. 3220FT1S
- For the Selection Guide, Load Ratings and Speed Limits, see the Link-Belt Flex-block Bearing Engineering section on pages 554 - 556.
- Note: Dimensions subject to change. Certified dimensions of ordered material furnished on request.

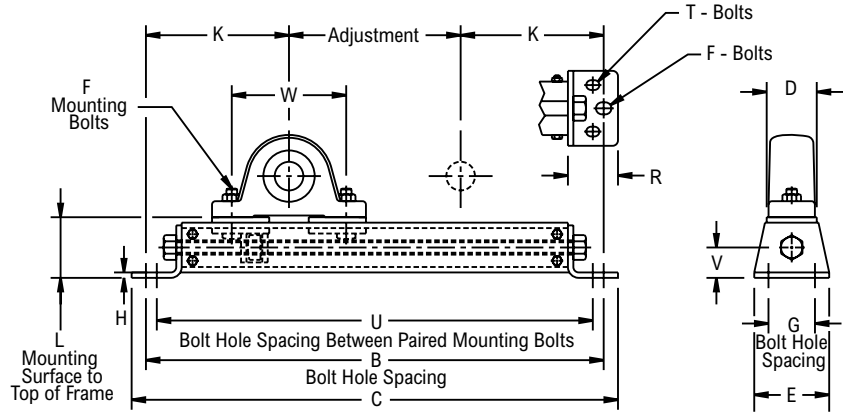
LC



Photo Shows a Light Duty Conveyor Take-Up Frame

Product Features

- Bolted steel frames
- 2 or 4-bolt frame mounting
- Bolt hole centers adjustable
- Pillow blocks not included
- See Features and Benefits for additional info on page 552.



Bearing Dimensions

Size Code	Adjust. Length	Part Number	Bolt Hole Spacing			L Mounting Surface to Top of Frame	C	D	E	F	H	K	R	T	V	W min	W max	Approx. Weight	
			B Frame	G Width Direction	U Between Pairs														
205	6	LC16	16	1 5/8	15 1/4	2 1/8	17	1 3/4	2 5/8	3/8	3/16	5	1 3/4	5/16	1 1/16	3	5 15/16	5.25	
	9	LC19	19		18 1/4													20	6.30
	12	LC112	22		21 1/4													23	6.60
210	6	LC26	19 1/8	2 1/8	18 1/8	2 11/16	20 1/4	2 3/8	3 1/8	1/2	1/4	6 9/16	2 3/16	3/8	1 11/32	3 3/4	7 1/4	10.00	
	9	LC29	22 1/8		21 1/8													23 1/4	10.20
	12	LC212	25 1/8		24 1/8													26 1/4	11.50
	18	LC218	31 1/8		30 1/8													32 1/4	13.80
211/212	9	LC39	25 5/16	2 3/4	24 1/16	3 5/16	26 9/16	3	4	5/8	5/16	8 5/32	2 3/4	1/2	1 5/8	4 1/4	9	20.40	
	12	LC312	28 5/16		27 1/16													29 9/16	22.25
	18	LC318	34 5/16		33 1/16													35 9/16	26.50
	24	LC324	40 5/16		39 1/16													41 9/16	33.00

Additional Notes

- Please call 1-866-REXNORD for availability
- For pillow block dimensions, see Pillow Block Ball Bearing section
- Note: Dimensions subject to change. Certified dimensions of ordered material furnished on request.

Engineering Information



Contents

Vibration Information
Shaft Size Tolerance
Setscrew Torque
Bearing Selection

Page

562
564
565
567

Vibration Analysis and Defect Frequency Information

Vibration analysis equipment is used to chart the amplitude and frequency of vibration on key areas of a machine. The theory behind predictive maintenance programs is to predict failures in order to reduce downtime costs. This way parts can be ordered and replaced on scheduled downtime without interrupting production.

Note: Vibration analysis is only effective as a trend analysis tool. It must be part of a thoroughly planned program that establishes "norms" for each individual

piece of equipment. Significant variations from these norms may then point to a problem. The problems must then be sized accordingly; does something need to be replaced, does it just need to be greased or adjusted? The "norms" must be well established in order to recognize an abnormal condition.

The following tables show the Vibration Frequency Coefficients.

Rex Roller Bearing Vibration Frequency Coefficients

Size Code	Roller Diameter (in)	Number of Rollers/Row	Pitch Diameter (in)	Contact Angle (deg)	RSF Roller Spin	FTF Fundamental Train	RPM Inner Ring Defect	RPFO Outer Ring Defect	RDF Roller Defect
2	0.347	13	1.754	18.833	0.0406	0.0068	0.1286	0.0880	0.0812
3	0.378	13	1.987	17.767	0.0424	0.0068	0.1280	0.0887	0.0847
4	0.354	15	2.173	16.317	0.0499	0.0070	0.1445	0.1055	0.0998
5	0.445	14	2.559	16.633	0.0466	0.0069	0.1361	0.0972	0.0932
6	0.408	17	2.796	14.983	0.0559	0.0072	0.1617	0.1217	0.1118
7	0.424	19	3.135	15.000	0.0606	0.0072	0.1790	0.1377	0.1211
8	0.467	19	3.459	14.050	0.0607	0.0072	0.1791	0.1376	0.1214
9	0.559	18	4.035	14.117	0.0591	0.0072	0.1701	0.1299	0.1182
10	0.615	19	4.711	14.300	0.0628	0.0073	0.1784	0.1383	0.1255
11	0.822	18	5.519	13.467	0.0548	0.0071	0.1717	0.1283	0.1095
12	0.874	20	6.077	12.583	0.0568	0.0072	0.1901	0.1433	0.1136
13	1.114	18	7.048	13.950	0.0515	0.0071	0.1730	0.1270	0.1030
14	1.386	16	8.113	14.167	0.0475	0.0070	0.1554	0.1113	0.0951
15	1.414	17	8.843	13.133	0.0509	0.0070	0.1637	0.1196	0.1017
16	1.535	18	9.823	12.250	0.0521	0.0071	0.1729	0.1271	0.1042

* There are two rows per bearing

* Table coefficient values multiplied by speed = hertz (cps) or HZ value X 60 = cycles per minute (cpm) frequency value

Link-Belt Roller Bearing Vibration Frequency Coefficients

Size Code	Roller Diameter (in)	Number of Rollers/Row	Pitch Diameter (in)	Contact Angle (deg)	RSF Roller Spin	FTF Fundamental Train	RPM Inner Ring Defect	RPFO Outer Ring Defect	RDF Roller Defect
B416	0.347	13	1.753	18.833	0.0406	0.0068	0.1286	0.0880	0.0812
B420	0.378	13	1.986	17.767	0.0424	0.0068	0.1280	0.0887	0.0847
B424	0.354	15	2.172	16.317	0.0499	0.0070	0.1445	0.1055	0.0998
B524									
B624									
B428	0.445	14	2.558	16.633	0.0466	0.0069	0.1361	0.0972	0.0932
B528									
B432	0.408	17	2.794	14.983	0.0559	0.0072	0.1617	0.1217	0.1118
B531									
B631									
B436	0.424	19	3.134	15.000	0.0606	0.0072	0.1790	0.1377	0.1211
B536									
B635									
B440	0.467	19	3.457	14.050	0.0607	0.0072	0.1791	0.1376	0.1214
B540									
B639									
B448	0.559	18	4.034	14.117	0.0591	0.0072	0.1701	0.1299	0.1182
B548									
B647									
B456	0.615	19	4.709	14.300	0.0628	0.0071	0.1784	0.1383	0.1255
B556									
B655									
B464	0.822	18	5.517	13.467	0.0548	0.0070	0.1717	0.1283	0.1095
B564									
B663									
B572	0.874	20	6.077	12.583	0.0568	0.0072	0.1901	0.1433	0.1136
B671									
B580	1.114	18	7.047	13.950	0.0515	0.0071	0.1730	0.1270	0.1030
B679									

* There are two rows per bearing

* Table coefficient values multiplied by speed = hertz (cps) or HZ value X 60 = cycles per minute (cpm) frequency value

Link-Belt Heavy Duty Ball Bearing Vibration Frequency Coefficients

Size Code	Ball Diameter (in)	Number of Balls	Pitch Diameter (in)	BSF Ball Spin	FTF Fundamental Train	BPFI Inner Ring Defect	BPFO Outer Ring Defect	BDF Ball Defect
312	0.3750	7	1.4173	0.0293	0.0062	0.0738	0.0428	0.0585
316	0.4375	7	1.7126	0.0305	0.0062	0.0732	0.0435	0.0610
319	0.4874	8	2.0079	0.0325	0.0063	0.0827	0.0507	0.0650
323	0.5313	8	2.2638	0.0335	0.0063	0.0823	0.0510	0.0672
324	0.5938	8	2.5591	0.0340	0.0063	0.0822	0.0512	0.0680
328	0.6875	8	2.8543	0.0327	0.0063	0.0827	0.0507	0.0652
331	0.7500	8	3.1496	0.0330	0.0063	0.0825	0.0508	0.0660
335	0.8125	8	3.4440	0.0333	0.0063	0.0823	0.0510	0.0667
339	0.8750	8	3.7402	0.0337	0.0063	0.0823	0.0510	0.0673
344	1.0000	8	4.3307	0.0342	0.0063	0.0820	0.0513	0.0683
347	1.0625	8	4.6260	0.0343	0.0065	0.0820	0.0513	0.0687
351	1.1250	8	4.9213	0.0345	0.0065	0.0818	0.0515	0.0692
356	1.2500	8	5.5118	0.0348	0.0065	0.0818	0.0515	0.0697
363	1.4375	8	6.2008	0.0340	0.0065	0.0817	0.0516	0.0680

* Table coefficient values multiplied by speed = hertz (cps) or HZ value X 60 = cycles per minute (cpm) frequency value

Link-Belt 6800 & 6600 Series Roller Bearing Vibration Frequency Coefficients

Size Code	RSF Roller Spin	FTF Fundamental Train	RPFI Inner Ring Defect	RPFO Outer Ring Defect
22209	0.0497	0.0070	0.1640	0.1188
22210	0.0530	0.0071	0.1730	0.1272
22211	0.0553	0.0071	0.1810	0.1352
22213	0.0523	0.0071	0.1730	0.1269
22215	0.0591	0.0072	0.1890	0.1438
22216	0.0553	0.0071	0.1810	0.1352
22217	0.0523	0.0071	0.1730	0.1269
22218	0.0524	0.0071	0.1730	0.1269
22220	0.0522	0.0071	0.1730	0.1269
22222	0.0493	0.0069	0.1650	0.1186
22224	0.0522	0.0071	0.1730	0.1269
22226	0.0524	0.0071	0.1730	0.1270
22228	0.0523	0.0071	0.1730	0.1269
22230	0.0522	0.0071	0.1730	0.1269
22232	0.0523	0.0071	0.1730	0.1269
22234	0.0492	0.0070	0.1650	0.1186
22236	0.0523	0.0071	0.1730	0.1269
22238	0.0573	0.0072	0.1900	0.1433
22240	0.0557	0.0071	0.1811	0.1356
22244	0.0540	0.0071	0.1818	0.1349
23048	0.0857	0.0075	0.2645	0.2187
23056	0.0826	0.0075	0.2563	0.2103

* There are two rows per bearing

* Table coefficient values multiplied by speed = hertz (cps) or HZ value X 60 = cycles per minute (cpm) frequency value

Link-Belt Ball Bearing Vibration Frequency Coefficients

Size Code	Ball Diameter (in)	Number of Balls	Pitch Diameter (in)	BSF Ball Spin	FTF Fundamental Train	BPFI Inner Ring Defect	BPFO Outer Ring Defect	BDF Ball Defect
203	0.2969	7	1.1220	0.0293	0.0062	0.0738	0.0428	0.0585
204	0.3125	8	1.3189	0.0332	0.0063	0.0825	0.0508	0.0633
205	0.3125	9	1.5157	0.0387	0.0067	0.0905	0.0595	0.0775
206	0.3750	9	1.8110	0.0385	0.0067	0.0905	0.0595	0.0770
207	0.4375	9	2.1063	0.0383	0.0067	0.0905	0.0595	0.0768
208	0.4688	9	2.3622	0.0367	0.0065	0.0912	0.0588	0.0733
209	0.5000	9	2.5590	0.0377	0.0065	0.0908	0.0592	0.0752
210	0.5000	10	2.7559	0.0445	0.0068	0.0985	0.0682	0.0888
211	0.5625	10	3.0512	0.0437	0.0068	0.0987	0.0680	0.0873
212	0.6250	10	3.3464	0.0430	0.0068	0.0988	0.0678	0.0862
213	0.6563	10	3.6417	0.0447	0.0068	0.0983	0.0683	0.0895
214	0.6563	10	3.6417	0.0451	0.0068	0.0982	0.0684	0.0903
215	0.6875	11	4.0354	0.0475	0.0068	0.1073	0.0760	0.0950
216	0.7813	11	4.6260	0.0470	0.0069	0.1074	0.0759	0.0941
217	0.7813	11	4.6260	0.0480	0.0070	0.1072	0.0762	0.0958
218	1.0000	10	5.5118	0.0454	0.0069	0.0981	0.0685	0.0908
220	1.0000	10	5.5118	0.0445	0.0068	0.0985	0.0682	0.0888

* Table coefficient values multiplied by speed = hertz (cps) or HZ value X 60 = cycles per minute (cpm) frequency value

Shaft Size Tolerance

A snug fit-up between shaft and bearing inner race is required for proper bearing performance. In fact, a press fit is necessary to obtain full basic dynamic capacity. As application conditions and requirements vary, fit-up and mounting requirements change as well.

A slip fit mounting in accordance with the shaft tolerances shown in the tables below will provide generally acceptable service life on normal applications under light to moderate load and speed conditions. A shaft tolerance resulting in looser fits (such as commercial grade shafting) may be expected to have greatly reduced reliability and increasing problems of shaft fret wear, bearing inner ring fracture and shaft slippage. In general, looser fits than recommended are feasible only for very light loading and lower speeds.

Shafting should be designed for adequate strength and stiffness for the intended application. It should be round, straight, free of nicks and burrs and of correct size.

If a special tolerance shaft is to be used, consideration should be given to the use of a precision tolerance bearing, particularly in the case of severe loading or high speed applications to obtain optimum bearing performance.

The tables below list shaft size tolerance information for various types of mounting and application conditions.

Recommended Roller Bearing Shaft Tolerance Table

Shaft Diameter	Recommended Shaft Tolerances	
	Setscrew Mounted	Adapter Mounted
thru 2"	+ .0000" to -.0005"	+ .000" to -.003"
2 1/16" to 4"	+ .0000" to -.0010"	+ .000" to -.004"
4 1/16" to 6"	+ .0000" to -.0015"	+ .000" to -.005"
6 1/16" to 13"	+ .0000" to -.0015"	+ .000" to -.006"
17mm to 50mm	+ .000mm to -.013mm	+ .00mm to -.07mm
55mm to 100mm	+ .000mm to -.025mm	+ .00mm to -.10mm
105mm to 150mm	+ .000mm to -.038mm	+ .00mm to -.13mm
155mm to 330mm	-	+ .00mm to -.15mm

Recommended Ball Bearing Shaft Tolerance Table

Shaft Diameter	Recommended Shaft Tolerances		
	Setscrew Mounted	Adapter Mounted	Centrik-Lok
thru 2"	+ .0000" to -.0005"	+ .000" to -.003"	+ .000" -.003"
2 1/16" to 4"	+ .0000" to -.0010"	+ .000" to -.004"	+ .000" -.004"
17mm to 50mm	+ .000mm to -.013mm	-	-
55mm to 100mm	+ .000mm to -.025mm	-	-

Recommended Sleeve Bearing Shaft Tolerance Table

Shaft Diameter	Recommended Shaft Tolerances
thru 2"	+ .000" to -.003"
2 1/16" to 4"	+ .000" to -.004"
4 1/16" to 6"	+ .000" to -.005"
6 1/16" to 13"	+ .000" to -.006"

Recommended Setscrew Torque Values

Proper tightening torque can be found in the below tables. Achieving these values will distort the set collars and spring load the setscrews to prevent their loosening during operation. If an Allen wrench is used as the torque wrench, place length of pipe over long end and pull until wrench begins to twist.

The axial load capacities listed in the below tables are for knurled cup setscrews having 90° spacing, tightened to recommended torque range on a shaft seat not harder than 35 Rockwell C. The axial load values may be used in design, as a safety factor has been applied.

The setscrew torque values and allowable axial loads are applicable to Rexnord Bearing products only. These values can not be applied to bearings manufactured by other vendors having different setscrew spacing, different type of setscrews and/or different size setscrews.

Rexnord Roller Bearing Seating Torque

Setscrew Size (in)	2000	3000	5000	Setscrew Torque Range (in-lb)	Axial Load Capacity 2000 & 3000 (lb)	Axial Load Capacity 5000 (lb)
5/16	2012-2104	3107		185	500	
3/8	2107-2200	3111-3115	5107-5115	325	650	1300
7/16	2203-2204	3203-3315	5200-5203	460	825	1650
1/2	2206-2308	3207-3308	5207-5307	680	990	1980
5/8	2311-2400	3315	5311-5507	1350	1320	2640
3/4			5515-5700	1600	1650	3300

Link-Belt Roller Bearing Seating Torque

Setscrew Size (in)	B22400	B22500	Setscrew Torque Range (in-lb)	Axial Load Capacity B22400 (lb)	Axial Load Capacity B22500 (lb)
5/16	B22412-420		185	500	
3/8	B22423-432	B22523-531	325	650	1300
7/16	B22435-436	B22532-535	460	825	1650
1/2	B22439-456	B22536-556	680	990	1980
5/8	B22459-464	B22559-580	1350	1320	2640

Link-Belt Ball Bearing Seating Torque

Setscrew Size (in)	Y200/W200 Eccentric Lock	U200 Setscrew	S200 Setscrew	U300 Setscrew	Setscrew Torque Range (in-lb)	Axial Load Capacity (lb)
#10		2B08-211	2B08-211	312	33-40	175
1/4	2B08-216	212-2E20	212-216	314-316	87-92	330
5/16	217-2E20	220-228	217-228	318-324	165-185	500
3/8	220-2E32	230-239	230-256	326-331	290-325	650
7/16	232-239	240-243		332-339	430-460	825
1/2		244-2E56		343-347	620-680	990
5/8		263-2E64		348-356	1225-1350	1320
3/4				363	2125-2350	1650

Setscrew Size (in)	CL200 Centrik-Lok	M_CL200 Centrik-Lok	Setscrew Torque Range (in-lb)
#10	212-2E20	216	65-72
1/4	220-228	219-224	151-168
5/16	230-239	227-235	313-348
3/8	240-2E64	239-256	540-600

Introduction to Load Ratings

The values shown in the Radial Load Rating Tables are used to select the most economical bearing capable of sustaining the required speed and load for the desired life. Do not depend entirely on the rated capacity to judge how well the complete mounted unit will perform. Environmental and maintenance conditions can detract from this performance. The realistic approach to mounted bearing application is to consider "theoretical" rated capacity of the base bearing plus the housing design, seals, method of securing to shaft, lubrication, etc., as they effect the desired life expectancy and the economics of overall equipment design.

Basis of Load Ratings

The Anti-Friction Bearing Manufacturer's Association (AFBMA), recommends the use of a standard formula for determining the basic rating of anti-friction bearings. The use of the formula determines the rating for any given bearing and is based upon failure from surface contact fatigue of the roller or race material.

The AFBMA Basic Load Rating definition may be thought of as having two basic principles involved; one being of a physical nature relating to a load carrying ability (Basic Load Rating) and the other taking into consideration failure level or probability of bearing survival (Rating Life).

The definitions of these principles are:

1. The "Basic Load Rating" of a bearing is that consistent stationary equivalent radial load which a group of apparently identical roller bearings with stationary outer ring can endure for one million revolutions of the inner ring.
2. The "Rating Life" of a group of apparently identical bearings is defined as "the number of revolutions that 90% of a group of bearings will complete or exceed before first evidence of fatigue develops." This is often referred to as L_{10} or B-10 Life.

C Rating

The common industry term "C" Rating inter-relates these two rating conditions. The "C" Rating is defined as "the equivalent radial load which may be imposed on the bearings to give an L_{10} (B-10) life of one million revolutions" (500 hours at 33 1/3 rpm). The "C" Rating is calculated from an empirical formula based on size and geometry. The empirical relationship is based on assumptions in several important areas; i.e., press fit mounting to shaft, adequate mineral oil lubrication, no misalignment, uniform loading, moderate speed and temperature, absolute cleanliness, etc. While it would appear logical that all bearings of identical geometry, dimensions and material should produce identical results under identical conditions, in reality, due to variations within specified tolerances of material and manufacturing, failures will occur at random periods of life. Ideally these failures should still result from metal fatigue rather than physical wear of the components. The "C" Rating can be expanded into combinations of load and speed to life hours by utilizing specified load-life relationships. These may then be referred to as the capacity ratings for any speed and life hours with the implied " L_{10} " survival probability consideration. This load rating for a given life condition is often termed Capacity Rating Or Rated Capacity and are shown in the Load Rating Tables in the front of each section.

Co Rating

The Basic Static Capacity (C_o) is that amount of radial or equivalent radial load that can be imposed on a non-rotating bearing without producing excessive brinelling. This rating applies to the performance of the internal parts of the roller bearing. For the vast majority of applications, a bearing can be run normally after sustaining a static load of C_o . First fracture of primary race components does not occur until well above the C_o Rating. C_o does not necessarily represent static strength of the housing or structure in which the bearing is mounted.

Conditions Affecting Rated Life

When the bearings are mounted in commercial housings and offered as a "package" to the user it should then be understood that the values shown in the catalog Load Rating Tables apply only to the base bearing under laboratory conditions. Common application factors which have an adverse effect on rated life are:

- 1 - Improper mounting (alignments, fit up to shaft)
- 2 - Contamination by abrasive or corrosive material
- 3 - Non-uniform load or vibration
- 4 - Inadequate or improper lubrication
- 5 - Excessive temperature or temperature change
- 6 - Excessive speed

The base bearing when mounted in a commercial housing frequently fails from other causes before it reaches the theoretical basis for the rated life. Thus, selection of housing style, seal type, mounting method, specific lubricant, etc., must also be considered to optimize life on the actual application.

Adjusted Rating Life

While actual results or "usable" bearing life is the primary interest of both those who design and those who utilize bearings, a great many factors impact the translation of "theoretical" rated capacity into actual performance. Once the theoretical bearing L_{10} life has been calculated, it can be adjusted for higher reliability, special bearing material properties, and/or operating condition effects on lubrication. Detailed information can be obtained from the Rexnord Engineering Department.

Theoretical Bearing L_{10} Life Calculation

While bearings are usually selected on the basis of capacity, there are occasions when they are selected based on calculated L_{10} life. The L_{10} life is defined as the number of revolutions (or hours) that 90% of a group of bearings will meet or exceed before evidence of raceway spalling fatigue occurs. The L_{10} life can be calculated using the following empirical formula:

Roller Bearing:

$$L_{10} = \frac{1 \times 10^6}{60 \times \text{RPM}} \left(\frac{C}{P_e} \right)^{10/3} = \text{Life in Hours}$$

Ball Bearing:

$$L_{10} = \frac{1 \times 10^6}{60 \times \text{RPM}} \left(\frac{C}{P} \right)^3 = \text{Life in Hours}$$

where C = C Rating

P_e = Equivalent Radial Load or
Required Radial Capacity

The basic dynamic load ratings, C , in this catalog have been increased significantly compared to previous values. Improved surface characteristics have been produced primarily by improving manufacturing and measuring techniques for the race surfaces. Along with the capability to rotate under higher loads, the static load ratings, C_o , have also been increased.

With the larger load ratings it may be possible to use smaller bearings (size code) for a given application. Caution is advised in such cases to consider the strength of the shaft and housing—especially when the applied load is not aimed directly into the machined mounting surface.

Bearing Selection

Optimum bearing performance is the result of selecting the bearing and the shaft to suit the particular application. Bearing size is often controlled by a shaft size selection, based on shaft bending and torsional stresses. In other applications, bearing load capacity is the determining design factor. In either case, the selection procedure outlined below is used to determine the bearing capacity required to meet the application requirements.

Bearing Selection Procedure

This procedure involves conversion of all forces and conditions into one resultant equivalent radial load on each bearing and utilization of the bearing load rating table.

STEP 1.

Determine all forces acting on the bearings. The following types of loading must be considered.

- A. Static loads - weight of shaft assembly and other equipment supported by the bearings. (When these are small in relation to applied loads they are often disregarded).
- B. Applied loads - forces applied on shaft during normal function of equipment and are determined prior to bearing selection.
- C. Drive loads - forces transmitted from power source to the shaft through belts, chains, gears, etc. (see Drive Load).
- D. Eccentric loads - centripetal force due to a designed unbalanced load rotating with shaft (see Eccentric Loads).

STEP 2.

Resolve the radial forces acting on the shaft into radial loads on each bearing. (See Translation of Shaft Forces into Bearing Loads)

STEP 3.

Combine the radial forces vertically to obtain a resultant radial load (P_r) at each bearing (see combining radial loads).

STEP 4.

Add or subtract all thrust forces (if any) to determine the total thrust load (P_t) acting on the shaft. Assume this thrust load is acting at the bearing with the greatest radial load (P_r).

STEP 5.

Calculate the equivalent radial load (P_e) using the applicable thrust formula. If no thrust is present, then $P_e = P_r$. (See selection guides)

STEP 6.

Apply the modification factors (M) and obtain a required radial capacity (P) to reflect actual application conditions. (See Load Modification Factors)

$$P = P_e \times M$$

STEP 7.

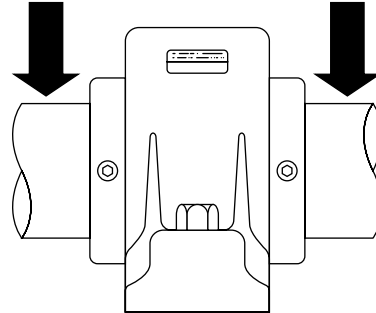
Select a bearing size from the load rating table at the front of each section. Use the largest calculated Required Radial Capacity value (P) and the application speed and life requirements in making the optimum selection. Usually, a single set collar bearing provides an adequate, economic selection. However, in applications involving shock and vibration, increased rigidity, or when shaft locking or housing strength is desired, a double set or adapter mount unit should be specified.

NOTE: If bearing selection has been made without consideration of shaft strength, shaft size (as indicated by bearing bore) should be checked.

Applied Loads

Each shaft performs a basic work function in a system, regardless of the type or style of equipment. The forces relating to this work function normally represent the primary load on the shaft and are most accurately determined by those responsible for total equipment design. When this load information is supplied, these loads are combined with other loadings to determine a bearing selection.

Radial Loads



Drive Loads

To determine the radial force on a shaft from a belt or chain drive where the horsepower being transmitted is known, the following formula should be used:

$$F = \frac{HP \times 126,000 \times K}{PD \times RPM} \quad \text{Formula (1)}$$

Where:

- F - Radial Force on Shaft
- HP - Horsepower transmitted
- PD - Pulley diameter or pitch diameter of sprocket or sheave in inches
- RPM - Revolutions per minute
- K - See Drive Tension Factors (below)
- 126,000 - A constant for conversion of horsepower, speed and pulley diameter to radial pounds of force

Drive Tension Factors - K:

While subject to considerable variations due to different installation and maintenance practice, the following Drive Tension Factors "K" are recommended for normal applications:

"K" Factors

Type of Drive	Normal Tension	4 or more V-belts, Tight Belts, Short Centers, High Ratios
Chain	1	1
V-belts (1 to 3 belts)	1.5	2
Flat Belts	2	3

Eccentric Loads

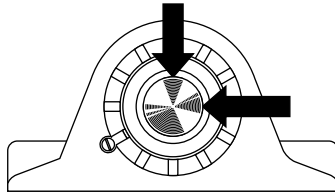
An unbalanced shaft generates a centripetal force which acts radially on the shaft per the following formula:

$$C.F. = .000028 \times r \times W \times (RPM)^2 \quad \text{Formula (2)}$$

C.F. = Centripetal Force (Lbs.)
 r = Radius of rotation of unbalanced load in inches
 W = Weight of unbalanced load in lbs.
 RPM = Revolutions per minute

Since the centripetal force varies in direction it should be added to the maximum combined load from other sources. A modification factor (see Load Modification Factors) must also be included on this type loading.

Bearing Selection



Translation of Shaft Forces into Bearing Loads

Any radial force (F) can be resolved into individual loads on each bearing. The amount of load supported by each bearing is determined from the summation of moments using the following formulas:

When the load (F) is between supports, it produces bearing loads (Fa, Fb) in same direction on both bearings (A & B), and equal to the applied load. (F = Fa + Fb).

An overhung load produces a bearing load (Fa) in the opposite direction of the far bearing (A); and since a lever arm is involved, the magnitude of load (Fb) on nearest bearing (B) will be greater than the overhung load (F), by the amount of load (Fa) on far bearing (A). (F = Fb - Fa).

$$F_a = \frac{F \times e}{c}$$

Formula (3)

$$F_b = \frac{F \times d}{c}$$

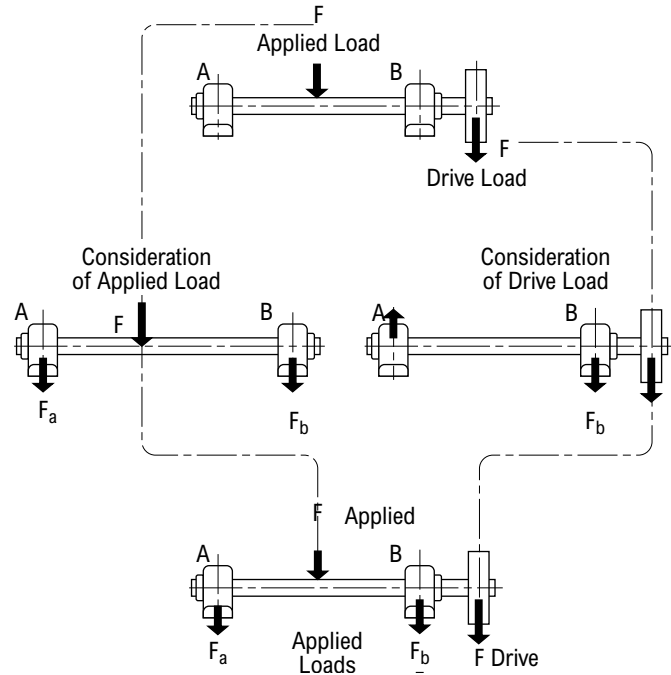
Formula (4)

Note Direction of Forces Fa, Fb

- F - Force on shaft required to transmit power and or other radial forces acting on shaft from one point
- Fa - Radial force on bearing "A"
- Fb - Radial force on bearing "B"
- c - Distance between bearing centerlines in inches
- d - Distance between centerline of bearing "A" and force "F" in inches
- e - Distance between centerline of bearing "B" and force "F" in inches

Combining Radial Loads

Typical applications involve both an applied load and a drive load. Normal Engineering Procedure would be to treat each load source separately, but to ultimately combine these loads as shown below:



In applications where all loads are in the same plane, the forces can be added or subtracted. However, in most applications, all radial forces are not in the same direction. Where two or more radial forces are not in the same plane, these forces should be changed to vertical and horizontal components as shown by the following formula:

$$F_v = \text{Force } F \text{ Sine } \angle \quad \text{Formula (5)}$$

$$F_h = \text{Force } F \text{ Cos } \angle \quad \text{Formula (6)}$$

Where:

Fv = Vertical component in lbs.

Fh = Horizontal component in lbs.

Sine \angle = Sine of angle between force "F" and horizontal

Cos \angle = Cos of angle between force "F" and horizontal

These horizontal and vertical components are combined to obtain a net horizontal force (Prh) and a net vertical force (Prv). The resultant radial force on a bearing is determined as follows:

$$P_r = \sqrt{P_{rv}^2 + P_{rh}^2} \quad \text{Formula (7)}$$

Where:

Pr = Resultant radial load

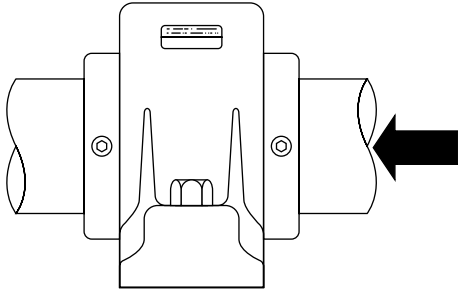
Prv = Total vertical radial load

Prh = Total horizontal radial load

Resultant radial loads (Pr) can also be determined graphically, using vectors representing both size and direction of imposed loads.

Bearing Selection

Pure Thrust Loads



Centrifugal pumps, propellers, drilling equipment, vertical shafts and screw conveyors represent types of equipment where one of the bearings supporting the shaft may be required to take primarily thrust loads. Rex units are capable of taking thrust loads in either direction.

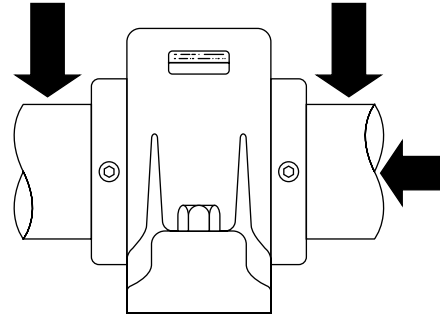
Thrust load ratings for units may be obtained as follows:

$$\text{Thrust Rating} = \frac{\text{Catalog Radial Load Rating}}{\text{Maximum Thrust Factor}}$$

The "Thrust Rating" is the maximum thrust load a bearing can withstand at the selected RPM and L₁₀ Life.

NOTE: Assume thrust load is supported by one bearing only. High thrust loads require special shaft and mounting considerations. Installation must also be considered to assure maximum performance.

Combined Radial and Thrust Loads



In many applications such as, helical, bevel or spiral-bevel gears the bearings are required to carry combined radial and thrust loads. Rex Bearings are in effect two single-row angular contact bearings having a common inner race with a spherical surface. They are, therefore, capable of carrying both radial and thrust loads in either direction.

For purposes of selection, it is always advisable to assume that, if any thrust loading is present, it is carried by the bearing with the heaviest radial load. (In most applications it is almost impossible to split a thrust load between two or more bearings. Also, unless floating units are used, it is difficult to mount bearings so that only one specific bearing carries all the thrust load imposed on a shaft.)

When both thrust and radial loads are involved, the formulas in the Thrust Table are used. The formula combine both loads into an equivalent radial load for which a bearing may be selected from the Load Rating Table. The correct formula is selected based upon size of the unit and percentage of thrust to radial load involved.

Equivalent Radial Load

When selecting a bearing for an application involving thrust loading, a shaft size range must be determined or estimated and bearing series decided to obtain a formula from the Thrust Table below. When a specific bearing has been selected from the Radial Load Rating Table as a result of the use of this formula from the Thrust Table, and its shaft size or style is outside the range of the original formula, the selection is not valid and the equivalent radial load (P_e) must be recalculated using the new formula related to that shaft size and bearing series.

Load Modification Factors

Normal calculations of bearing loads do not take into consideration special load conditions such as oscillatory, shock, or variable loads. To take such conditions into account, load modification factors are applied to the calculated load. These factors, whether termed load modification factors, application factors, or service factors, are all intended to allow extra bearing capacity to offset inordinate loading conditions.

Since factor selection is always a matter of judgement, even personnel experienced in bearing selection and application vary in their assessment of factors for individual application conditions.

The factors listed below are intended only as a general guide and may be adjusted for particular situations.

Oscillatory Loads

Some bearing applications involve shaft oscillation instead of complete rotation. The table below lists the M factors corresponding to the maximum included angle of oscillation. The applied load is multiplied by this M factor to determine the equivalent radial load. When using the load rating tables, the vertical column headings represent cycles per minute instead of RPM.

Basic failure mode changes at oscillation angles below 30° - consult Rexnord.

Oscillation Factors

φ	30	60	90	120	150	180
M	.58	.72	.81	.89	.95	1.00

φ = Included oscillation angle - degrees

M = Modifying factor.

Shock Loads

Shock is an actual dynamic load on the bearing. Consequently capacity must be allocated to handle shock loading in addition to the basic dynamic loading normally calculated or analyzed in an application.

Shock Factors

Operating Condition	Frequency Overload		
	Occasional 33%	Frequent 67%	Continuous 100%
No Shock	1.00	1.00	1.00
Light Shock	1.14	1.24	1.33
Moderate Shock	1.32	1.52	1.67
Heavy Shock or Extreme Vibration	1.52	1.80	2.00

Resultant Load

The Resultant Radial Load P_r or Equivalent Radial Load P_e multiplied by selected Modifying Factors will give the Required Radial Capacity P in terms of catalog load rating tables.

For Radial Load Only:

$$P = P_r \times M \quad \text{Formula (9)}$$

For combined Radial and Thrust Loads as well as Thrust Loads:

$$P = P_e \times M \quad \text{Formula (10)}$$

If safety factors or other allowances have been included in the initial bearing loads to reflect application conditions, then do not duplicate those factors from the following table to avoid exaggerating bearing loads. In case two or more factors are involved, the values should be multiplied together to obtain the combined "M" Factor.

Variable Loads

In many cases, a bearing is subjected to varying loads and speeds.

The following formula calculates the equivalent load on the bearing when this occurs.

$$P_e = \sqrt[3.33]{\frac{P_1^{3.33}n_1t_1 + P_2^{3.33}n_2t_2 + \dots P_n^{3.33}n_nt_n}{N}} \quad \text{Formula (11)}$$

where P_1, P_2, P_n are the loads (in lbf) acting at speeds n_1, n_2, n_n (in rpm)

t_1, t_2, t_n are the durations (in decimal percentage) of each load and speed

$$N = t_1n_1 + t_2n_2 + \dots t_n n_n$$

For cases where the load is variable but the speed is constant, the following simplified formula is used:

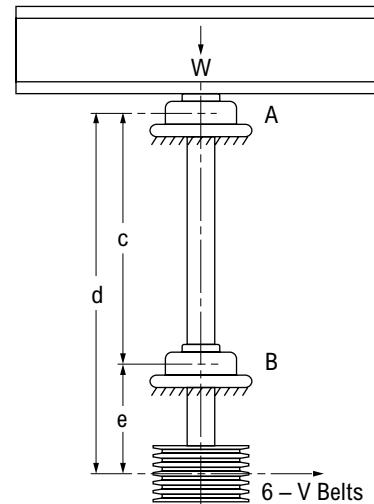
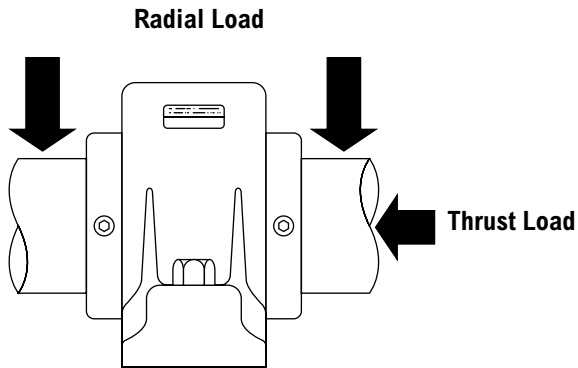
$$P_e = \sqrt[3.33]{P_1^{3.33}t_1 + P_2^{3.33}t_2 + \dots P_n^{3.33}t_n} \quad \text{Formula (12)}$$

When the load varies from a minimum to a maximum load and is a continuous and gradual change, the equivalent load is calculated using the following formula:

$$P_e = \frac{P_{min} + 2P_{max}}{3} \quad \text{Formula (13)}$$

For calculations of more complex loading conditions, consult the Rexnord Bearing Engineering Department.

Application Example



Determine the Flange Block Requirements for the Mixing Tub as shown:

Operating Data	Symbol	Value
Wt. of mixing tub and load	W	2400 lbs.
Horsepower	HP	10
Speed	RPM	200
"K" Factor	K	2
Sheave Pitch Dia.	PD	14"
Bearing "A" to "B"	c	24"
Bearing "A" to Sheave	d	32"
Bearing "B" to Sheave	e	8"
L-10 Life required	-	15,000 Hrs.

Radial force on shaft from V-Belt drive (F) is calculated by using formula (1),

$$F = \frac{HP \times 126,000 \times K}{PD \times RPM} = \frac{10 \times 126,000 \times 2}{14 \times 200} = 900 \text{ lbs.}$$

F1 load from drive, will produce radial loads on bearings "A" and "B." These radial loads are determined by using formulae (3) and (4)

Bearing "A"

$$F_a = \frac{F \times e}{c} = \frac{900 \times 8}{24} = 300 \text{ lbs.}$$

$$F_b = \frac{F \times d}{c} = \frac{900 \times 32}{24} = 1200 \text{ lbs.}$$

A bearing selection is made based upon bearing "B" because it carries the greater radial load. The total thrust load, 2400 lbs. from the weight of the mixing tub and load, should also be considered as acting on that bearing.

The thrust and radial loads are combined to an equivalent radial load by selecting the proper X, Y Factors in the Bearing Selection Guide.

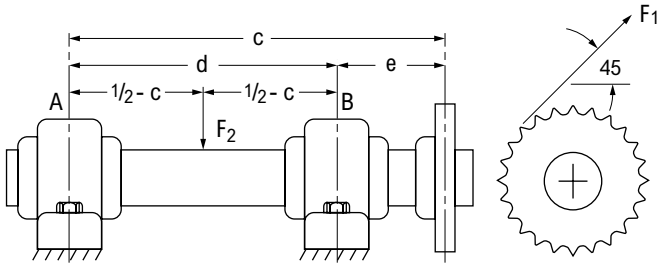
In this case use:

$$P_e = .67 P_r + 2.60 P_t = .67 (1200) + 2.60 (2400) \\ = 804 + 6240 = 7044$$

Referring to the Rexnord Roller Bearing Radial Load Rating Table, a size code 9 bearing has a rating of 9855 lbs. at 200 rpm and 15,000 hours life. Using the derating factor at the bottom of the table, a Normal Duty 2211 bearing has a rating of $(1-.15) \times 9855 = 8377$ lbs. This exceeds the 7044 lbs. of equivalent radial load that was calculated so the 2211 is satisfactory. Therefore, a ZB2211 Normal Duty Flange Block would be selected. Using the formula and C, the bearings L₁₀ life would be:

$$L_{10} = \frac{1 \times 10^6}{60 \times 200} \left[\frac{46,800 \times .85}{7044} \right]^{10/3} = 26,728 \text{ hours}$$

Application Example - Chain and Belt Drives



Radial load on bearings consist of two parts: from the dead load and from the drive. Because these loads act in different directions, they will have to be combined by using formula 5, 6 and 7.

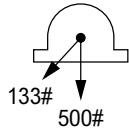
Bearing "A"

Load from weight in center of shaft:

$$F_{2a} = \frac{1000}{2} = 500 \text{ lbs. because weight is centered between both bearings. Load is downward.}$$

Load from drive:

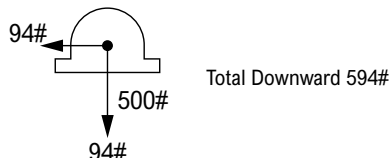
$$F_{1a} = \frac{F_1 \times e}{c} = \frac{1200 \times 10}{90} = 133 \text{ lbs. at } 45^\circ \text{ downward}$$



To combine the loads, the 133 lb. load must be broken up into vertical and horizontal loads.

$$F_v = F_{1a} \times \sin 45^\circ = 133 \times .707 = 94 \text{ lb. vertical downward}$$

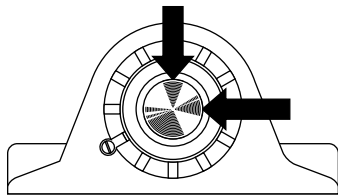
$$F_h = F_{1a} \times \cos 45^\circ = 133 \times .707 = 94 \text{ lb. horizontal}$$



Now combine the total downward load and horizontal load.

$$P_r = \sqrt{(94)^2 + (594)^2} = 602 \text{ lbs. radial load on "A"}$$

Combined Radial Loads



Determine the pillow block requirements for the application shown below:

Operating Data	Symbol	Value
Load from drive	F1	1200 lbs.
Dead load on shaft	F2	1000 lbs.
Speed	RPM	1000
L ₁₀ Life required	-	15,000 Hrs.
Bearing "A" to "B"	c	90"
Bearing "A" to sprocket	d	100"
Bearing "B" to sprocket	e	10"
Sin 45°		.707
Cos 45°		.707

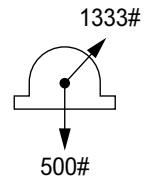
Bearing "B"

Load from weight in center of shaft:

$$F_{2b} = \frac{1000}{2} = 500 \text{ lbs. downward}$$

Load from drive:

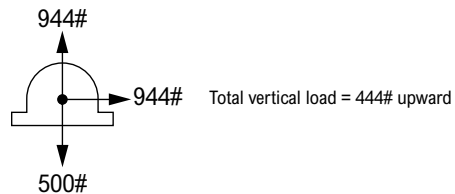
$$F_{1b} = \frac{F_1 \times d}{c} = \frac{1200 \times 100}{90} = 1333 \text{ lbs. at } 45^\circ \text{ upward}$$



Now break up the 1333 lb. load into horizontal and vertical loads:

$$F_v = F_{1b} \times \sin 45^\circ = 1333 \times .707 = 944 \text{ lbs. vertical upward}$$

$$F_h = F_{1b} \times \cos 45^\circ = 1333 \times .707 = 944 \text{ lbs. horizontal}$$



Now combining the total upward load and horizontal load

$$P_r = \sqrt{(444)^2 + (944)^2} = 1042 \text{ lbs. radial load on "B"}$$

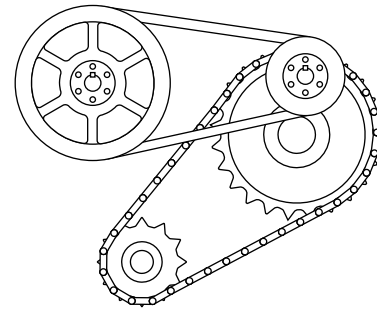
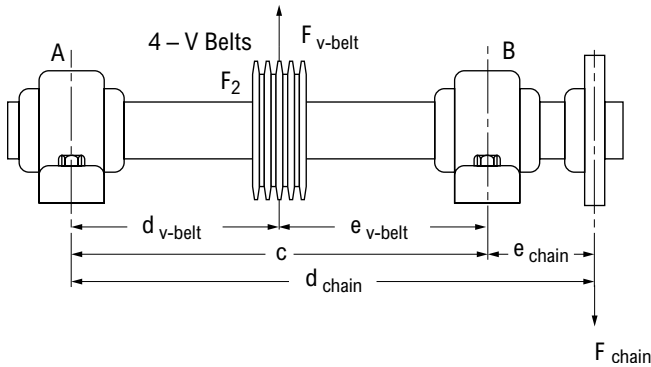
Bearing selection will be based on Bearing "B" because it has the highest load of the two bearings. Referring to the Rexnord Roller Bearing Radial Load Rating Table, a size code 3 bearing has a rating of 1858 lbs. at 1000 rpm and 15,000 hours life. Using the derating factor at the bottom of the table, a Normal Duty 2102 bearing has a rating of (1-.15) X 1858 = 1579 lbs. This exceeds the 1042 lbs. of equivalent radial load that was calculated for Bearing "B" so the 2102 is satisfactory. Therefore, a ZA2102 Normal Duty Pillow Block would be selected.

Using the formula and the C Rating, the bearings L₁₀ life would be:

$$L_{10} = \frac{1 \times 10^6}{60 \times 1000} \left[\frac{14,300 \times .85}{1042} \right]^{10/3} = 59,949 \text{ hours}$$

Application Example - Chain and Belt Drives

Determine the pillow block requirements for the jack shaft driven by a chain sprocket and power take-off through a 4-V Belt Sheave as shown:



Operating Data	Symbol	Value
Horsepower	HP	30
Speed	RPM	200
L ₁₀ Life required	-	80,000 Hrs.
"K" Factor	K _{v-belt}	2
"K" Factor	K _{chain}	1
Sprocket Pitch Dia	PD _{chain}	10"
Sheave Pitch Dia	PD _{v-belt}	15"
Bearing "A" to "B"	c	20"
Bearing "A" to sheave	d _{v-belt}	10"
Bearing "A" to sprocket	d _{chain}	30"
Bearing "B" to sheave	e _{v-belt}	10"
Bearing "B" to sprocket	e _{chain}	10"

Radial force on shaft from chain drive (F_{chain}) is calculated by using Formula (1).

$$F_{chain} = \frac{HP \times 126,000 \times K}{PD \times RPM} = \frac{30 \times 126,000 \times 1}{10 \times 200} = 1890 \text{ lbs.}$$

(NOTE: Chain pull in this case is downward)

Radial force on shaft from V-Belt power take-off (F_{v-belt}) is calculated by using Formula (1).

$$F_{v-belt} = \frac{HP \times 126,000 \times K}{PD \times RPM} = \frac{30 \times 126,000 \times 2}{15 \times 200} = 2520 \text{ lbs.}$$

(NOTE: V-belt pull in this case is upward)

Radial load on bearings is now determined by combining resulting loads from both chain pull and V-Belt pull using Formula (3) and (4).

Bearing "A"

Load from chain pull

$$F_a = \frac{F_{chain} \times e_{chain}}{c} = \frac{1890 \times 10}{20} = 945 \text{ lbs.}$$

(NOTE: F_a from chain pull is upward)

Load from V-Belt pull

$$F_a = \frac{F_{v-belt} \times e_{v-belt}}{c} = \frac{2520 \times 10}{20} = 1260 \text{ lbs.}$$

(NOTE: F_a from V-Belt is upward)

Combining both F_a s and because both loads are upward add both loads to get total:

$$\text{Total load on "A"} = 945 \text{ lbs.} + 1260 \text{ lbs.} = 2205 \text{ lbs.}$$

Bearing "B"

Load from chain pull

$$F_b = \frac{F_{chain} \times d_{chain}}{c} = \frac{1890 \times 30}{20} = 2835 \text{ lbs.}$$

(NOTE: F_b from chain pull is downward)

Load from V-Belt pull

$$F_b = \frac{F_{v-belt} \times d_{v-belt}}{c} = \frac{2520 \times 10}{20} = 1260 \text{ lbs.}$$

(NOTE: F_b from V-Belt is upward)

Combining both F_b s and because one load is upward and one is downward, subtract to get total:

$$\text{Total load on "B"} = 2835 \text{ lbs.} - 1260 \text{ lbs.} = 1575 \text{ lbs.}$$

Bearing selection will be based on Bearing "A" because it has the highest load of the two bearings. Referring to the Rexnord Roller Bearing Radial Load Rating Table, a size code 7 bearing has a rating of 3466 lbs. at 200 rpm and 80,000 hours life. Using the derating factor at the bottom of the table, a Normal Duty 2203 bearing has a rating of $(1-.15) \times 3466 = 2946$ lbs. This exceeds the 2205 lbs. of equivalent radial load that was calculated for Bearing "A" so the 2203 is satisfactory. Therefore, a ZA2203 Normal Duty Pillow Block would be selected.

Using the formula and the C Rating, the bearings L₁₀ life would be:

$$L_{10} = \frac{1 \times 10^6}{60 \times 200} \left[\frac{27,200 \times .85}{2205} \right]^{10/3} = 210,092 \text{ hours}$$



866-REXNORD/866-739-6673 (Within the US)
414-643-2366 (Outside the US)
www.rexnord.com

Why Choose Rexnord?

When it comes to providing highly engineered products that improve productivity and efficiency for industrial applications worldwide, Rexnord is the most reliable in the industry. Commitment to customer satisfaction and superior value extend across every business function.

Delivering Lowest Total Cost of Ownership

The highest quality products are designed to help prevent equipment downtime and increase productivity and dependable operation.

Valuable Expertise

An extensive product offering is accompanied by global sales specialists, customer service and maintenance support teams, available anytime.

Solutions to Enhance Ease of Doing Business

Commitment to operational excellence ensures the right products at the right place at the right time.

REXNORD

Rexnord Company Overview

Rexnord is a growth-oriented, multi-platform industrial company with leading market shares and highly trusted brands that serve a diverse array of global end markets.

Process & Motion Control

The Rexnord Process & Motion Control platform designs, manufactures, markets and services specified, highly engineered mechanical components used within complex systems where our customers' reliability requirements and the cost of failure or downtime are extremely high.

Water Management

The Rexnord Water Management platform designs, procures, manufactures and markets products that provide and enhance water quality, safety, flow control and conservation.